

		PAGINA Page Seite
<b>MODULO MOTORIZZATO RADIALE</b> Radial driven tool Radial angetriebenes Werkzeug		TKW 010.5.00
<b>MODULO MOTORIZZATO RADIALE 2 USCITE IN Y</b> Radial single side twin head driven tool in Y Radial angetriebenes Werkzeug 2 Ausgaenge in Y		TKW 080.5.00
<b>MODULO MOTORIZZATO ASSIALE</b> Axial driven tool Axial angetriebenes Werkzeug		TKW 150.5.10
<b>MODULO MOTORIZZATO ASSIALE BISPORGENTE</b> Axial opposite face twin driven tool Axial angetriebenes Werkzeug halb vorspringend		TKW 240.5.10

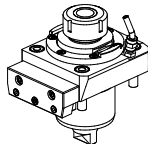

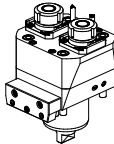

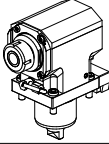
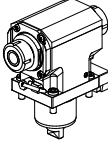
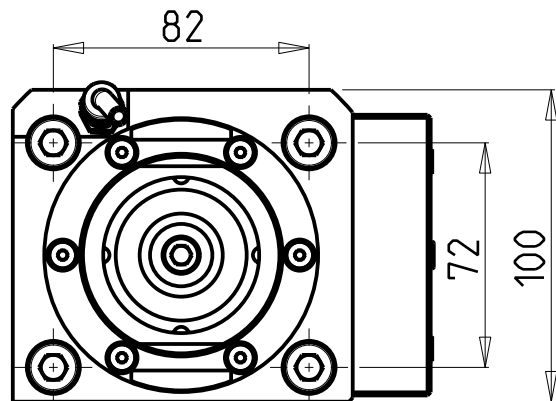
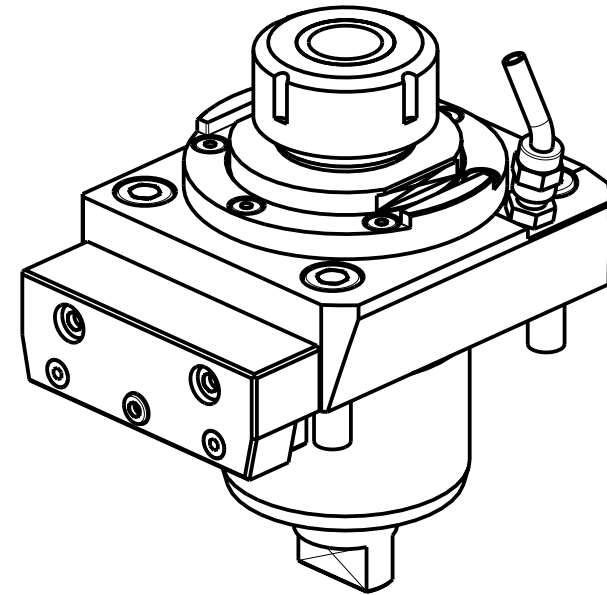
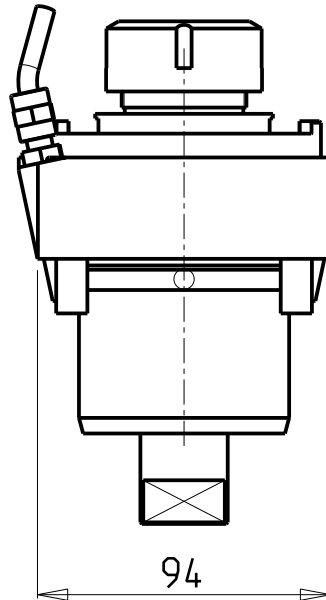
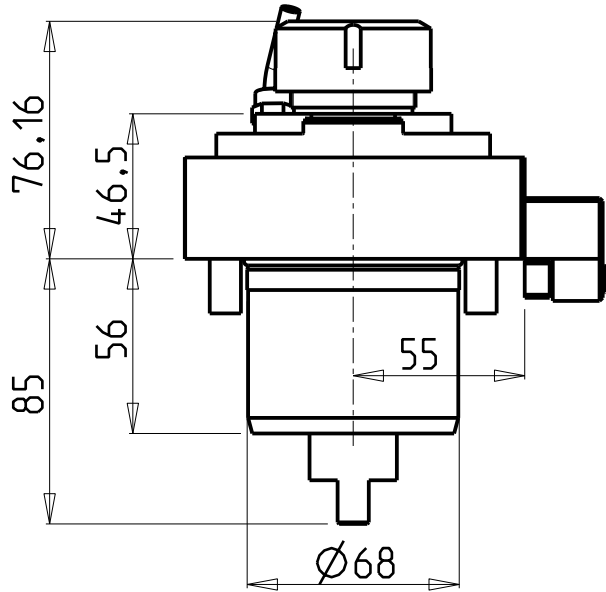

- Chiave inclusa
- Key included
- Schlüssel inbegriffen

Cod. MT	Cod. TAKISAWA	Mandrino Spindle Spindel	I	RPM	Coppia Max Max Torque Max Drehmoment	Lubrificazione est. Ext. coolant Ausenkuehlung	CHIAVI NON INCLUSE Keys not included Schlüssel nicht einbegriffen
TKW 0190132	GM81999-440	ER32	1:1	6000	60Nm	X	CHSTER32 OKU04 30007 ▪

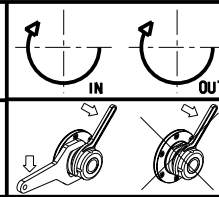
TAKISAWA  
 MOD: TY2000Y/YS/CS  
 MODULO MOTORIZZATO RADIALE  
 Radial driven tool  
 Radial angetriebenes Werkzeug



**M.T. srl**  
 Via Casino Albini 480  
 Tel. 0541/956034-957884  
 Fax 0541/956341  
 47842 S. GIOVANNI IN M. (RN)  
 e-mail: mtma@mtmarchetti.com  
 http://www.mtmarchetti.com

PRODUZIONE MODULI ROTANTI  
  
 PAGINA TKW010-5-00

Subject to change without notice.

## ATTENZIONE - ATTENTION - ACHTUNG

- Per lo smontaggio degli utensili utilizzare sempre la chiave di contrasto come indicato nel manuale d'uso.
- For disassembly of the tools use always the contrast key as mentioned in the user instructions.
- Fuer das Abmontieren der Werkzeuge immer den Gegenschlüssel benutzen wie in der Bedienungsanleitung erwaeht.

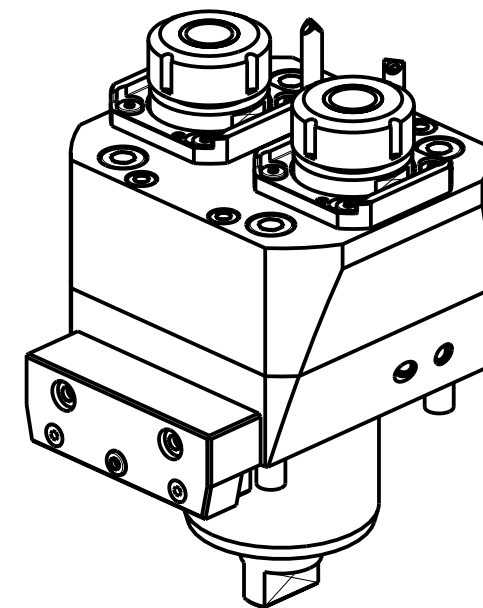
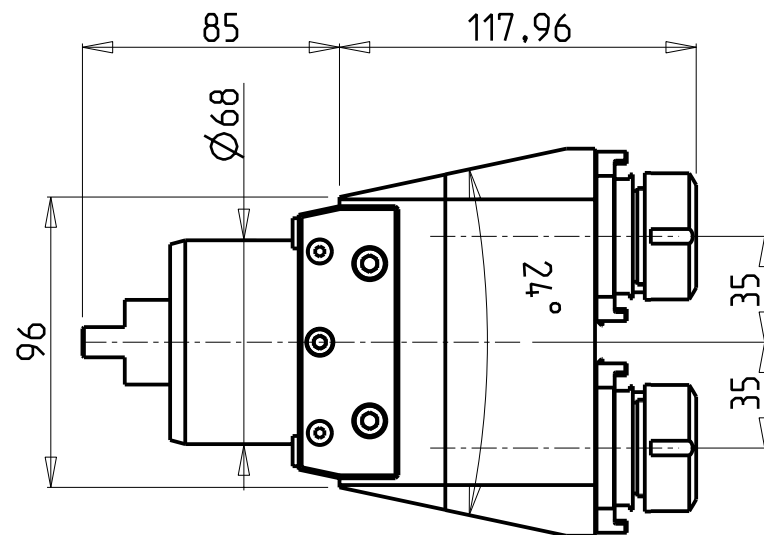
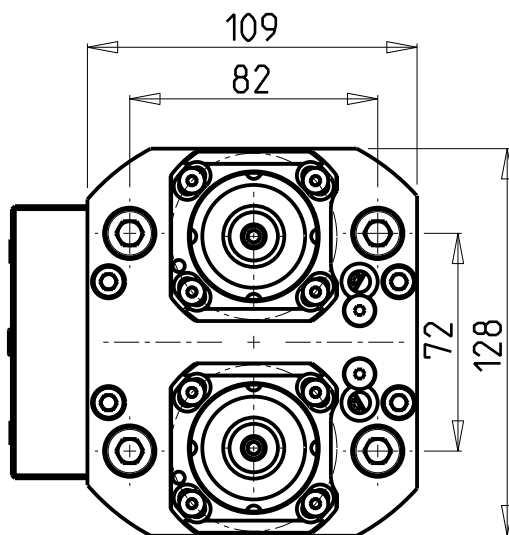

Cod. MT	Mandrino Spindle Spindel	I	RPM	Coppia Max Max Torque Max Drehmoment	Lubrificazione int. Coolant through Innenkuehlung	Lubrificazione est. Ext. coolant Ausenkuehlung	CHIAVI NON INCLUSE Keys not included Schlüssel nicht einbegriffen
TKW 0210125	ER25	1:1	6000	40Nm		X	OKU0290009 ▪ CHSTER25
TKW 0210225	ER25	1:1	6000	40Nm	P=70bar	X	OKU0290009 ▪ CHSTER25

- Chiave inclusa
- Key included
- Schlüssel inbegriffen

TAKISAWA  
MOD: TY2000Y/YS/CS

MODULO MOTORIZZATO RADIALE 2 USCITE IN Y  
Radial single side twin head driven tool in Y  
Radial angetriebenes Werkzeug 2 Ausgaenge in Y

Subject to change without notice.

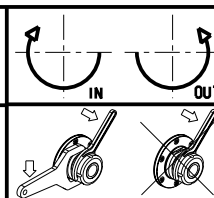

**M.T. srl**  
Via Casino Albini 480  
Tel. 0541/956034-957884  
Fax 0541/956341  
47842 S. GIOVANNI IN M. (RN)  
e-mail: mtma@mtmarchetti.com  
http://www.mtmarchetti.com

PRODUZIONE MODULI ROTANTI



PAGINA TKW080-5-00

**ATTENZIONE - ATTENTION - ACHTUNG**

- Per lo smontaggio degli utensili utilizzare sempre la chiave di contrasto come indicato nel manuale d'uso.
- For disassembly of the tools use always the contrast key as mentioned in the user instructions.
- Fuer das Abmontieren der Werkzeuge immer den Gegenschlüssel benutzen wie in der Bedienungsanleitung erwäehnt.

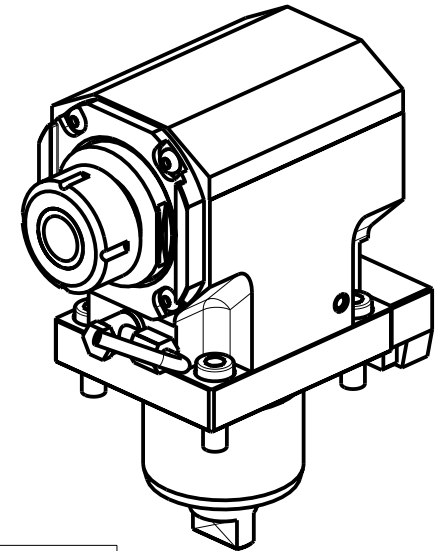
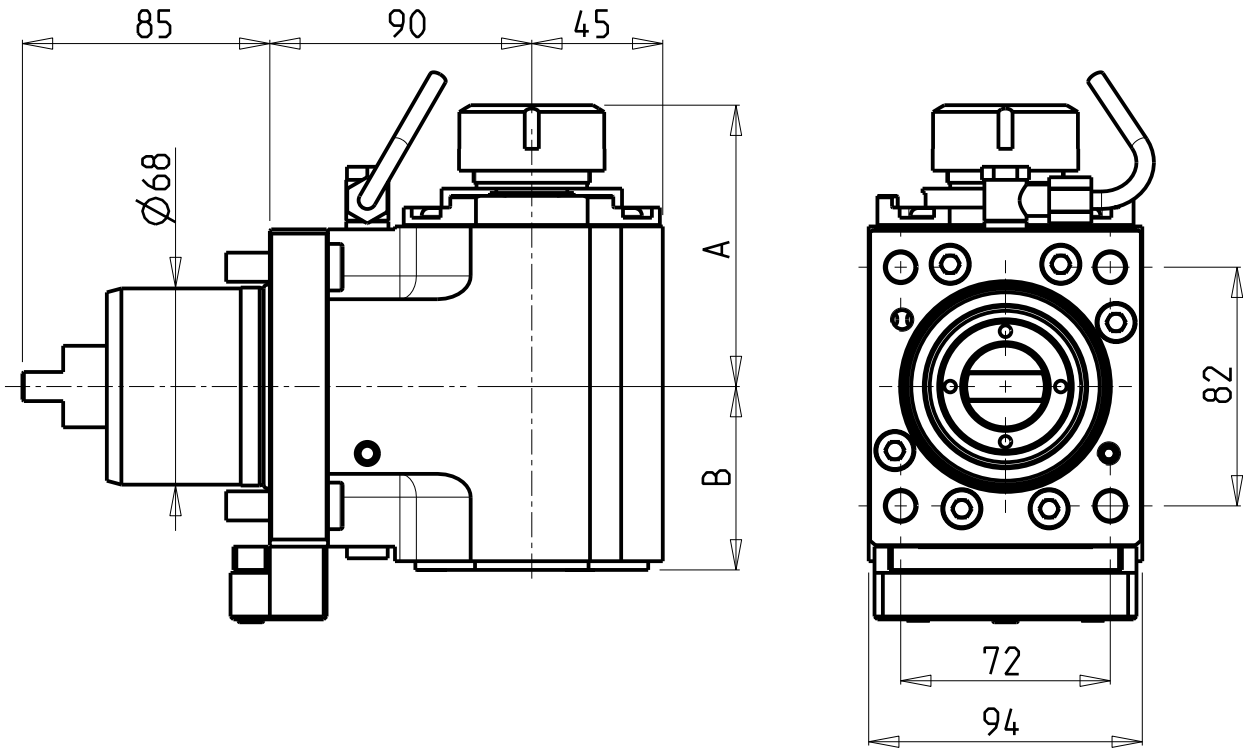

- Chiave inclusa
- Key included
- Schluessel inbegriffen

Cod. MT	Cod. TAKISAWA	Mandrino Spindle Spindel	I	RPM	Coppia Max Max Torque Max Drehmoment	Lubr.interna Coolant through Innenkuehlung	Lubr.esterna Ext. coolant Aussenkuehlung	A	B	CHIAVI NON INCLUSE Keys not included Schluessel nicht einbegriffen	
TKW 0180132	GM81999-441	ER32	1:1	6000	60Nm	-	X	96.7	63	CHSTER32	OKU0430007 ▪
TKW 0180140	-	ER40	1:1	6000	60Nm	-	X	99.7	63	CHSTER40	OKU0430007 ▪
TKW 0180232	-	ER32	1:1	6000	60Nm	P=70bar	X	96.7	79.5	CHSTER32	OKU0430007 ▪
TKW 0180240	-	ER40	1:1	6000	60Nm	P=70bar	X	99.7	79.5	CHSTER40	OKU0430007 ▪

**TAKISAWA**

MOD: TY2000Y/YS/CS

MODULO MOTORIZZATO ASSIALE

Axial driven tool

Axial angetriebenes Werkzeug

Subject to change without notice.

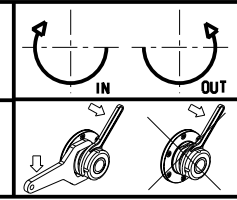

**M.T. srl**  
 Via Casino Albini 480  
 Tel. 0541/956034-957884  
 Fax 0541/956341  
 47842 S. GIOVANNI IN M. (RN)  
 e-mail: mtma@mtmarchetti.com  
 http://www.mtmarchetti.com

PRODUZIONE MODULI ROTANTI



PAGINA TKW 150-5-10

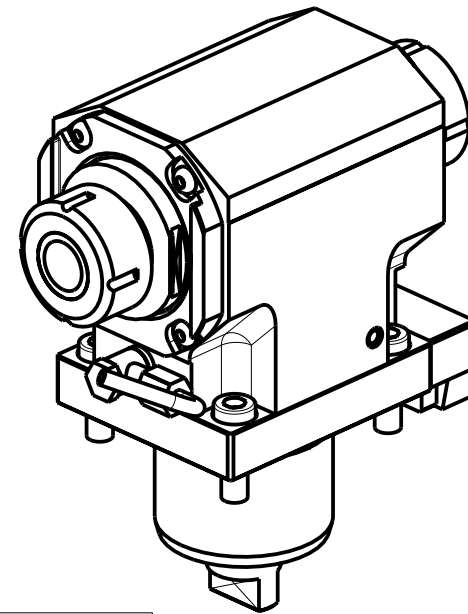
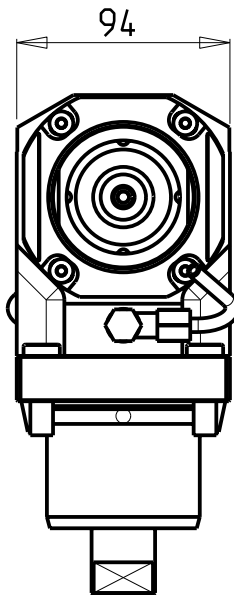
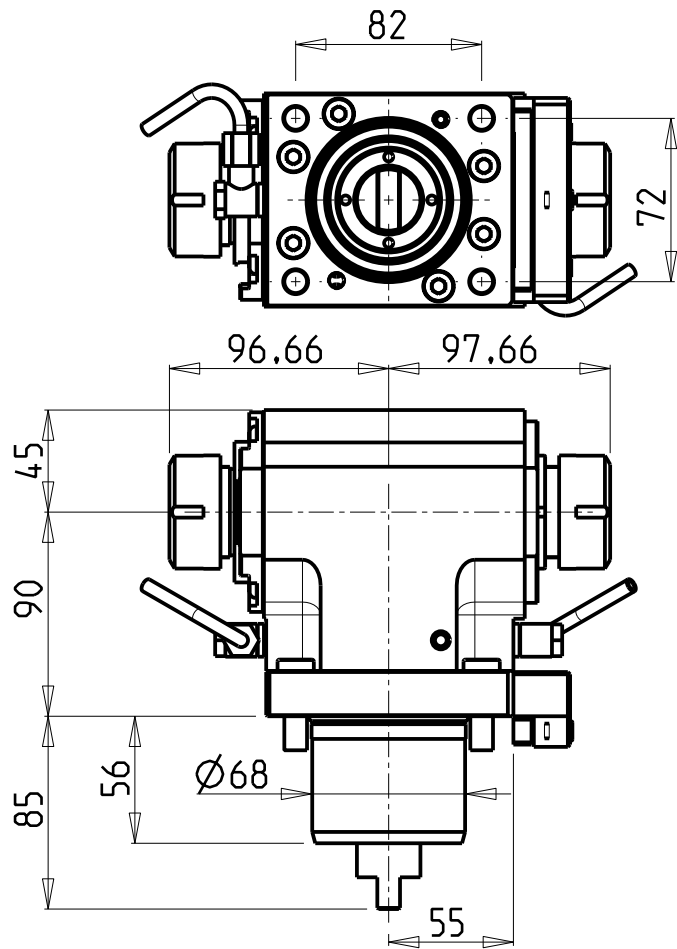

**ATTENZIONE - ATTENTION - ACHTUNG**

- Per lo smontaggio degli utensili utilizzare sempre la chiave di contrasto come indicato nel manuale d'uso.
- For disassembly of the tools use always the contrast key as mentioned in the user instructions.
- Fuer das Abmontieren der Werkzeuge immer den Gegenschlüssel benutzen wie in der Bedienungsanleitung erwaeht.

- Chiave inclusa
- Key included
- Schluessel inbegriffen

Cod. MT	Mandrino Spindle Spindel	I	RPM	Coppia Max Max Torque Max Drehmoment	Reversibile lato mandrino/contromandrino Reversible sub/main spindle side Umkehrbare Spindel-seite/ Gegenspindel-seite	Lubr.esterna Ext. coolant Aussenkuehlung	CHIAVI NON INCLUSE Keys not included Schluessel nicht einbegriffen
TKW 0200132	ER32+ER32	1:1	6000	60Nm	X	X	CHSTER32 OKU0430007 *

TAKISAWA  
MOD: TY2000Y/YS/CS

MODULO MOTORIZZATO ASSIALE BISPORGENTE  
Axial opposite face driven tool  
Axial angetriebenes Werkzeug halb vorspringend

Subject to change without notice.

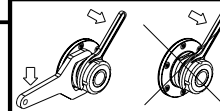

**M.T. srl**  
Via Casino Albini 480  
Tel. 0541/956034-957884  
Fax 0541/956341  
47842 S. GIOVANNI IN M. (RN)  
e-mail: mtma@mtmarchetti.com  
http://www.mtmarchetti.com

PRODUZIONE MODULI ROTANTI



PAGINA TKW 240-5-10