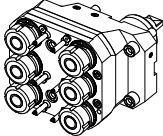
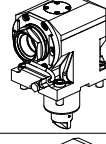
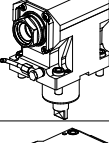
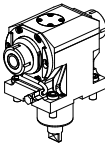
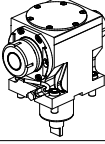
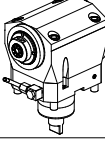
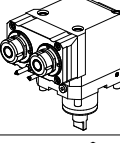
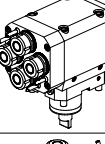
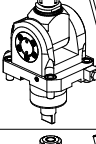
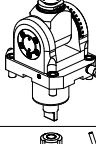
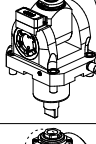
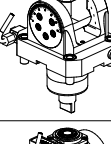
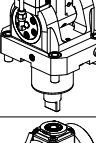
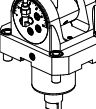
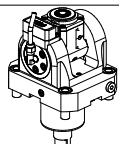
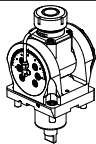
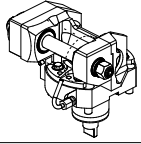
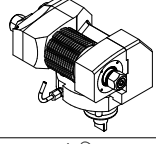
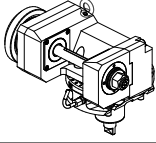
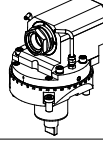
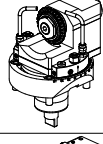
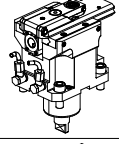
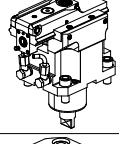
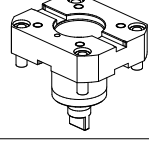
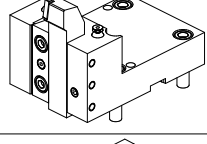
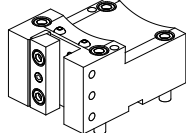
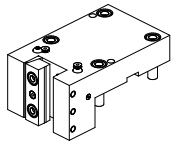
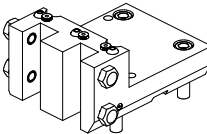
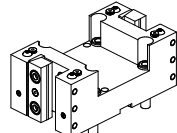
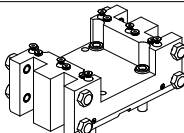
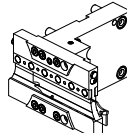
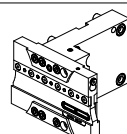
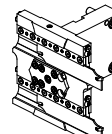
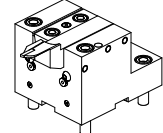
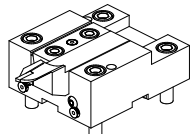
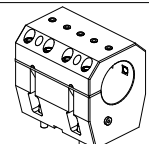
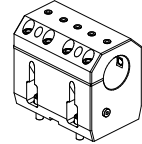
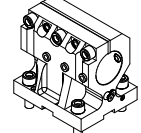

		PAGINA Page Seite
MODULO MOTORIZZATO RADIALE Radial driven tool Radial angetriebenes Werkzeug		TKW 010.7.00
MODULO MOTORIZZATO RADIALE MTSK Radial MTSK driven tool Radial MTSK angetriebenes Werkzeug		TKW 010.7.00.K
MODULO MOTORIZZATO RADIALE ALTA PRESSIONE Radial driven tool high pressure Radial angetriebenes Werkzeug hochdruck		TKW 010.7.20
MODULO MOTORIZZATO RADIALE MTSK ALTA PRESSIONE Radial MTSK driven tool high pressure Radial MTSK angetriebenes Werkzeug hochdruck		TKW 010.7.20.K
MODULO MOTORIZZATO RADIALE MAGGIORATO Radial reinforced driven tool Radial angetriebenes Werkzeug vergrößert		TKW 020.7.00
MODULO MOTORIZZATO RADIALE MAGGIORATO MTSK Radial MTSK reinforced driven tool Radial MTSK angetriebenes Werkzeug vergrößert		TKW 020.7.00.K
MODULO MOTORIZZATO RADIALE RIDOTTO 1=2:1 DISASSATO IN Z 45mm Radial geared-down 1=2:1 driven tool re-directed in Z by 45mm Radial angetriebenes Werkzeug untersetzt 1=2:1 achsversetzt in Z um 45mm		TKW 030.7.20
MODULO MOTORIZZATO RADIALE DISASSATO IN Z 45mm Radial driven tool re-directed in Z by 45mm Radial angetriebenes Werkzeug achsversetzt in Z um 45mm		TKW 033.7.10
MODULO MOTOR. RADIALE MOLTIPLICATO 1=1:2 DISASSATO IN Z 45mm Radial geared-up 1=1:2 driven tool re-directed in Z by 45mm Radial angetriebenes Werkzeug uebersetzt 1=1:2 achsversetzt in Z um 45mm		TKW 033.7.30
MODULO MOTORIZZATO RADIALE MOLTIPLICATO 1=1:5 Radial geared-up 1=1:5 driven tool Radial angetriebenes Werkzeug uebersetzt 1=1:5		TKW 059.7.00
MODULO MOTORIZZATO RADIALE 2 USCITE IN Y Radial single side twin head driven tool in Y Radial angetriebenes Werkzeug 2 Ausgaenge in Y		TKW 080.7.00
MODULO MOTORIZZATO RADIALE 2 USCITE IN Z Radial single side twin head driven tool in Z Radial angetriebenes Werkzeug 2 Ausgaenge in Z		TKW 090.7.00

		PAGINA Page Seite
<p>MODULO MOTORIZZATO RADIALE 6 USCITE Radial 6 head driven tool Radial angetriebenes Werkzeug 6 Ausgaenge</p>		TKW 110.7.00
<p>MODULO MOTORIZZATO RADIALE ROVESCiato DISASSATO IN Z Radial inverted driven tool re-directed in Z Radial angetriebenes Werkzeug ungekehrt achsversetzt in Z</p>		TKW 120.7.30
<p>MODULO MOTORIZZATO RADIALE DISASSATO 50mm ORIENTABILE ±25° Radial ±25° adjustable angle driven tool re-directed by 50mm Radial angetriebenes Werkzeug schwenkbar ±25° achsversetzt um 50mm</p>		TKW 135.7.00
<p>MODULO MOTORIZZATO ASSIALE Axial driven tool Axial angetriebenes Werkzeug</p>		TKW 150.7.10
<p>MODULO MOTORIZZATO ASSIALE MTSK Axial MTSK driven tool Axial MTSK angetriebenes Werkzeug</p>		TKW 150.7.10.K
<p>MODULO MOTORIZZATO ASSIALE Axial driven tool Axial angetriebenes Werkzeug</p>		TKW 170.7.10
<p>MODULO MOTORIZZATO ASSIALE MTSK Axial MTSK driven tool Axial MTSK angetriebenes Werkzeug</p>		TKW 170.7.10.K
<p>MODULO MOTORIZZATO ASSIALE ARRETRATO Axial rear-set driven tool Axial angetriebenes Werkzeug zurueckversetzt</p>		TKW 180.7.10
<p>MODULO MOTORIZZATO ASSIALE RIDOTTO I=2:1 Axial geared-down I=2:1 driven tool Axial angetriebenes Werkzeug untersetzt I=2:1</p>		TKW 190.7.10
<p>MODULO MOTORIZZATO ASSIALE MOLTIPLICATO I=1:2 Axial geared-up I=1:2 driven tool Axial angetriebenes Werkzeug uebersetzt I=1:2</p>		TKW 200.7.10
<p>MODULO MOTORIZZATO ASSIALE MTSK PER POLIGONATURA INTERNA H=90mm Axial MTSK driven tool for internal polygon-making H=90mm Axial MTSK angetriebenes Werkzeug fuer interne Facettierung H=90mm</p>		TKW 231.7.10.K
<p>MODULO MOTOR. ASSIALE 2 USCITE IN Y PER POLIGON. INTERNA H=90mm Axial Single side twin head driven tool in Y for internal polygon-making H=90mm Axial angetriebenes Werkzeug 2 Ausgaenge in Y fuer interne Facettierung H=90mm</p>		TKW 233.7.10

		PAGINA Page Seite
MODULO MOTORIZZATO ASSIALE BISPORGENTE Axial opposite face twin driven tool Axial angetriebenes Werkzeug halb vorspringend		TKW 240.7.10
MODULO MOTORIZZATO ASSIALE BISPORGENTE MTSK Axial MTSK opposite face twin driven tool Axial MTSK angetriebenes Werkzeug halb vorspringend		TKW 240.7.10.K
MODULO MOTORIZZATO ASSIALE BISPORGENTE RIDOTTO 1=2:1 Axial geared-down 1=2:1 opposite face twin driven tool Axial angetriebenes Werkzeug halb vorspringend untersetzt 1=2:1		TKW 247.7.10
MODULO MOTORIZZATO ASSIALE BISPORGENTE MOLTIPLICATO 1=1:2 Axial geared-up 1=1:2 opposite face twin driven tool Axial angetriebenes Werkzeug halb vorspringend uebersetzt 1=1:2		TKW 250.7.10
MODULO MOTORIZZATO ASSIALE 2 USCITE IN Y Axial single side twin head driven tool in Y Axial angetriebenes Werkzeug 2 Ausgaenge in Y		TKW 260.7.10
MODULO MOTORIZZATO ASSIALE 4/8 USCITE Axial multiple 4/8 outlet driven tool Axial angetriebenes Mehrspindel-Werkzeug 4/8 Ausgaenge		TKW 270.7.00
MODULO MOTORIZZATO ORIENTABILE 0-90° 0-90° adjustable angle driven tool Angetriebenes Werkzeug schwenkbar 0-90°		TKW 330.7.00
MODULO MOTORIZZATO ORIENTABILE ±90° ±90° adjustable angle driven tool Angetriebenes Werkzeug schwenkbar ±90°		TKW 333.7.00
MODULO MOTORIZZATO ORIENTABILE ±90° CON NONIO DIGITALE ±90° adjustable angle driven tool with digital display Angetriebenes Werkzeug schwenkbar ±90° mit digital display		TKW 333.7.01
MODULO MOTORIZZATO ORIENTABILE ±90° ±90° adjustable angle driven tool Angetriebenes Werkzeug schwenkbar ±90°		TKW 335.7.00
MODULO MOTORIZZATO ORIENTABILE ±90° CON NONIO DIGITALE ±90° adjustable angle driven tool with digital display Angetriebenes Werkzeug schwenkbar ±90° mit digital display		TKW 335.7.01
MODULO MOTORIZZATO ORIENTABILE ±90° MOLTIPLICATO 1=1:2 ±90° adjustable angle driven tool geared-up 1=1:2 Angetriebenes Werkzeug schwenkbar ±90° uebersetzt 1=1:2		TKW 336.7.00

		PAGINA Page Seite
<p>MOD. MOTOR. ORIENTABILE $\pm 90^\circ$ MOLTIPL. 1:2 CON NONIO DIGITALE $\pm 90^\circ$ adjustable angle driven tool geared-up 1:2 with digital display Angetriebenes Werkzeug schwenkbar $\pm 90^\circ$ uebersetzt 1:2 mit digital display</p>		TKW 336.7.01
<p>MODULO MOTORIZZATO ORIENTABILE $\pm 90^\circ$ $\pm 90^\circ$ adjustable angle driven tool Angetriebenes Werkzeug schwenkbar $\pm 90^\circ$</p>		TKW 339.7.00
<p>MODULO MOTORIZZATO PORTACREATORE Driven gear hobber Angetriebenes Zahnradwaelzfraes-Werkzeug</p>		TKW 340.7.00
<p>MODULO MOTORIZZATO PORTACREATORE MAGGIORATO Reinforced gear hobber Angetriebenes Zahnradwaelzfraes-Werkzeug vergroessert</p>		TKW 340.7.60
<p>MODULO MOTORIZZATO PORTACREATORE (TAGLIA GRANDE) Driven gear hobber (big size) Angetriebenes Zahnradwaelzfraes-Werkzeug (grosse version)</p>		TKW 340.7.80
<p>MODULO MOTORIZZATO ASSIALE MTSK PER POWER SKIVING H=106mm Axial MTSK driven tool for Power Skiving H=106mm Axial MTSK angetriebenes Werkzeug fuer Power Skiving H=106mm</p>		TKW 350.7.00.K
<p>MODULO MOTORIZZATO PER VITI SENZA FINE Driven tool for worm screws Angetriebenes werkzeug fuer schrauben ohne ende</p>		TKW 359.7.00
<p>MODULO MOTORIZZATO STOZZATORE CORSA 50mm H=94mm Slotting driven tool 50mm stroke H=94mm Keilnutenstossmaschine 50mm Hub H=94mm</p>		TKW 360.7.00
<p>MODULO MOTORIZZATO STOZZATORE CORSA 25mm H=94mm Slotting driven tool 25mm stroke H=94mm Keilnutenstossmaschine 25mm Hub H=94mm</p>		TKW 360.7.01
<p>INTERFACCIA PER MODULI BIGLIA Biglia tooling adapter cartridge Adapter-Patrone fuer Biglia Werkzeuge</p>		TKW 380.7.00
<p>PORTAUTENSILE RADIALE SINGOLO QD=25mm / QD=1" / QD=20mm / QD=3/4" Radial single static tool QD=25mm / QD=1" / QD=20mm / QD=3/4" Radial Single-Werkzeughalter QD=25mm / QD=1" / QD=20mm / QD=3/4"</p>		TKW 423.7.00
<p>PORTAUTENSILE RADIALE SINGOLO QD=25mm / QD=20mm Radial single static tool QD=25mm / QD=20mm Radial Single-Werkzeughalter QD=25mm / QD=20mm</p>		TKW 424.7.00

		PAGINA Page Seite
<p>PORTAUT. RAD. SINGOLO ARRETR. QD=25mm / QD=1" / QD=20mm / QD=3/4" Radial rear-set single static tool QD=25mm / QD=1" / QD=20mm / QD=3/4" Radial Single-Werkzeughalter zurueckver. QD=25mm / QD=1" / QD=20mm / QD=3/4"</p>		TKW 433.7.00
<p>PORTAUT. RADIALE SOVRAPPOSTO QD=25mm / QD=1" / QD=20mm / QD=3/4" Radial single side twin static tool QD=25mm / QD=1" / QD=20mm / QD=3/4" Radial Werkzeughalter ueberlagert QD=25mm / QD=1" / QD=20mm / QD=3/4"</p>		TKW 442.7.00
<p>PORTAUTENSILE RADIALE DOPPIO QD=25mm / QD=1" / QD=20mm / QD=3/4" Radial double static tool QD=25mm / QD=1" / QD=20mm / QD=3/4" Radial Doppel-Werkzeughalter QD=25mm / QD=1" / QD=20mm / QD=3/4"</p>		TKW 453.7.00
<p>PORTAUT. RADIALE DOPPIO SOVRAPP. QD=25mm / QD=1" / QD=20mm / QD=3/4" Radial double side twin static tool QD=25mm / QD=1" / QD=20mm / QD=3/4" Radial Doppel-Werkzeughalter ueberlagert QD=25mm / QD=1" / QD=20mm / QD=3/4"</p>		TKW 463.7.00
<p>PORTAUTENSILE PER LAMA DOPPIO Radial double blade holder Radial Doppel-Abstechhalter</p>		TKW 520.7.00
<p>PORTAUTENSILE PER LAMA DOPPIO CON LUBRIFICAZIONE INTERNA Radial double blade holder with internal coolant Radial Doppel-Abstechhalter mit Innenkuehlung</p>		TKW 520.7.04
<p>PORTAUTENSILE PER LAMA DOPPIO E SOVRAPPOSTO Radial double twin-side blade holder Radial Doppel-Abstechhalter ueberlagert</p>		TKW 525.7.00
<p>PORTAUTENSILE ASSIALE SINGOLO QD=25mm / QD=1" / QD=20mm / QD=3/4" Axial single static tool QD=25mm / QD=1" / QD=20mm / QD=3/4" Axial Single-Werkzeughalter QD=25mm / QD=1" / QD=20mm / QD=3/4"</p>		TKW 552.7.00
<p>PORTAUTENSILE ASSIALE RIBASSATO SINGOLO QD=25mm / QD=20mm Axial single lower height static tool QD=25mm / QD=20mm Axial Single-Werkzeughalter abgeflacht QD=25mm / QD=20mm</p>		TKW 562.7.00
<p>PORTAUTENSILE ASSIALE PER BARENO Ø80mm H=110mm Axial single boring bar holder Ø80mm H=110mm Axial Bohrhalter Ø80mm H=110mm</p>		TKW 580.7.20
<p>PORTAUTENSILE ASSIALE PER BARENO Ø60mm H=110mm Axial single boring bar holder Ø60mm H=110mm Axial Bohrhalter Ø60mm H=110mm</p>		TKW 590.7.20
<p>PORTAUTENSILE ASSIALE PER BARENO Ø50mm / Ø2" H=80mm Axial single boring bar holder Ø50mm / Ø2" H=80mm Axial Bohrhalter Ø50mm / Ø2" H=80mm</p>		TKW 610.7.20

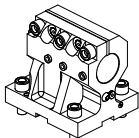
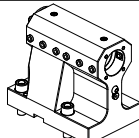
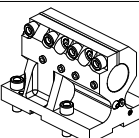
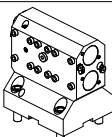
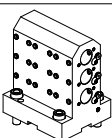
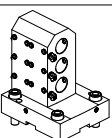
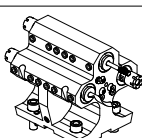
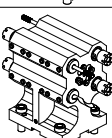
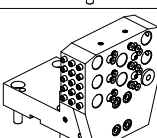
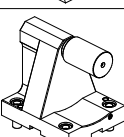
		PAGINA Page Seite
<p>PORTAUTENSILE ASSIALE PER BARENO $\varnothing 40\text{mm}$ / $\varnothing 1\ 1/2''$ H=80mm Axial single boring bar holder $\varnothing 40\text{mm}$ / $\varnothing 1\ 1/2''$ H=80mm Axial Bohrhälter $\varnothing 40\text{mm}$ / $\varnothing 1\ 1/2''$ H=80mm</p>		TKW 630.7.20
<p>PORTAUTENSILE ASSIALE PROLUNGATO PER BARENO $\varnothing 40\text{mm}$ H=115mm Axial single extended boring bar holder $\varnothing 40\text{mm}$ H=115mm Axial Bohrhälter verlaengert $\varnothing 40\text{mm}$ H=115mm</p>		TKW 760.7.10
<p>PORTAUTENSILE ASSIALE PROLUNGATO PER BARENO $\varnothing 40\text{mm}$ H=80mm Axial single extended boring bar holder $\varnothing 40\text{mm}$ H=80mm Axial Bohrhälter verlaengert $\varnothing 40\text{mm}$ H=80mm</p>		TKW 760.7.20
<p>PORTAUTENSILE ASSIALE PER BARENO 2+2 POSIZIONI $\varnothing 32\text{mm}$ / $\varnothing 1\ 1/4''$ Axial 2+2 position boring bar holder $\varnothing 32\text{mm}$ / $\varnothing 1\ 1/4''$ Axial Bohrhälter 2+2 Positionen $\varnothing 32\text{mm}$ / $\varnothing 1\ 1/4''$</p>		TKW 872.7.00
<p>PORTAUTENSILE ASSIALE PER BARENO 3+3 POSIZIONI $\varnothing 25\text{mm}$ / $\varnothing 1''$ Axial 3+3 position boring bar holder $\varnothing 25\text{mm}$ / $\varnothing 1''$ Axial Bohrhälter 3+3 Positionen $\varnothing 25\text{mm}$ / $\varnothing 1''$</p>		TKW 894.7.00
<p>PORTAUTENSILE ASSIALE ARRETRATO PER BARENO 3 POSIZIONI $\varnothing 25\text{mm}$ / $\varnothing 1''$ Axial 3 position rear set boring bar holder $\varnothing 25\text{mm}$ / $\varnothing 1''$ Axial Bohrhälter 3 Positionen zurueckversetzt $\varnothing 25\text{mm}$ / $\varnothing 1''$</p>		TKW 904.7.00
<p>PORTAUTENSILE ASSIALE PER BARENO 3+3 POSIZIONI $\varnothing 32\text{mm}$ / $\varnothing 1\ 1/4''$ Axial 3+3 position boring bar holder $\varnothing 32\text{mm}$ / $\varnothing 1\ 1/4''$ Axial Bohrhälter 3+3 Positionen $\varnothing 32\text{mm}$ / $\varnothing 1\ 1/4''$</p>		TKW 912.7.00
<p>PORTAUTENSILE ASSIALE PER BARENO 4+4 POSIZIONI $\varnothing 25\text{mm}$ / $\varnothing 1''$ Axial 4+4 position boring bar holder $\varnothing 25\text{mm}$ / $\varnothing 1''$ Axial Bohrhälter 4+4 Positionen $\varnothing 25\text{mm}$ / $\varnothing 1''$</p>		TKW 922.7.00
<p>PORTAUTENSILE ASSIALE PER BARENO 8 POSIZIONI $\varnothing 20\text{mm}$ / $\varnothing 3/4''$ Axial 8 position boring bar holder $\varnothing 20\text{mm}$ / $\varnothing 3/4''$ Axial Bohrhälter 8 Positionen $\varnothing 20\text{mm}$ / $\varnothing 3/4''$</p>		TKW 933.7.00
<p>CONTROPUNTA PER CONTROMANDRINO Tailstock for subspindle Gegenspintz fuer Gegenspindel</p>		TKW 950.7.00

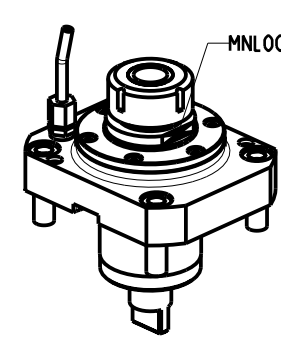
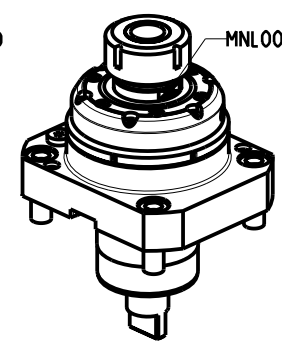
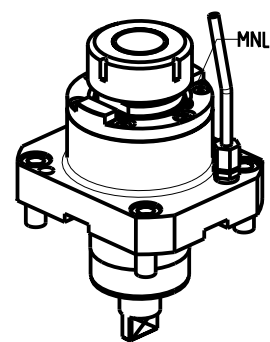
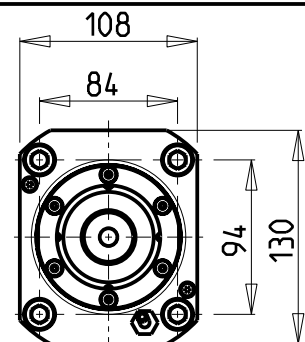
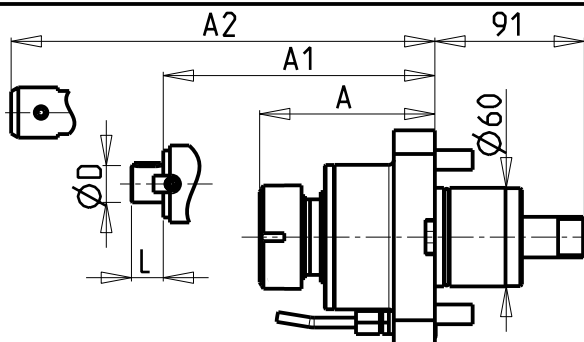

- Chiave inclusa
- Key included
- Schluessel inbegriffen

Cod. MT	Cod. MORI-SEIKI	Mandrino Spindle Spindel	I	RPM	Coppia Max Max Torque Max Drehmoment	Lubrificazione int. Coolant through Innenkuehlung	Lubrificazione est. Ext. coolant Aussenkuehlung	A	A1	A2	D	L	CHIAVI NON INCLUDE Keys not included Schluessel nicht einbegriffen	
													OKU0650004	CHSTER
MNL0020532	T32206	ER32	1:1	6000	100Nm	-	X	104.16	-	-	-	-	OKU0650004	CHSTER32
MNL0020140	T32213	ER40	1:1	6000	100Nm	-	X	106.66	-	-	-	-	OKU0650004	CHSTER40
MNL0021532	-	ER32	1:1	6000	100Nm	P=30bar	X	104.16	-	-	-	-	OKU0650004	CHSTER32
MNL0021140	-	ER40	1:1	6000	100Nm	P=30bar	X	106.66	-	-	-	-	OKU0650004	CHSTER40
MNL0020632	-	ER32	1:1	6000	100Nm	-	X	144.16	-	-	-	-	OKU0650004	CHSTER32
MNL0021632	-	ER32	1:1	6000	100Nm	P=30bar	X	144.16	-	-	-	-	OKU0650004	CHSTER32
MNL0020732	-	ER32	1:1	6000	100Nm	P=30bar	X	107.66	-	-	-	-	CHUB36	CHSTER32
MNL0021617	-	Ø16x17	1:1	6000	100Nm	-	X	-	116	-	16	17	OKU0650004	CH_VTCROCE_M08
MNL0020116	-	Ø16x17	1:1	6000	100Nm	P=30bar	X	-	116	-	16	17	OKU0650004	CH_VTCROCE_M08
MNL0022219	-	Ø22x19	1:1	6000	100Nm	-	X	-	106	-	22	19	OKU0650004	CH_VTCROCE_M10
MNL0020122	-	Ø22x19	1:1	6000	100Nm	P=30bar	X	-	106	-	22	19	OKU0650004	CH_VTCROCE_M10
MNL0022721	-	Ø27x21	1:1	6000	100Nm	-	X	-	81.5	-	27	21	OKU0650004	CH_VTCROCE_M12
MNL0022519	-	Ø1" x19	1:1	6000	100Nm	-	X	-	81.5	-	1"	21	OKU0650004	CH_VTCROCE_M12
MNL0020525	-	Ø1" x19	1:1	6000	100Nm	P=30bar	X	-	84.5	-	1"	21	OKU0650004	CH_VTCROCE_M12
MNL0022132	-	ER32 CORTO-SHORT-KURZ	1:1	6000	100Nm	-	X	75.76	-	-	-	-	CHUB46	CHSTER32
MNL0022140	-	ER40 CORTO-SHORT-KURZ	1:1	6000	100Nm	-	X	89.66	-	-	-	-	CHUB46	CHSTER40
MNL0020120	-	WELDON 20	1:1	6000	100Nm	-	X	-	-	99.5	-	-	-	-
MNL0020125	-	WELDON 25	1:1	6000	100Nm	-	X	-	-	109	-	-	-	-
MNL0020132	-	WELDON 32	1:1	6000	100Nm	-	X	-	-	125.5	-	-	-	-
MNL0020220	-	WELDON 20	1:1	6000	100Nm	P=30bar	X	-	-	99.5	-	-	-	-
MNL0020425	-	WELDON 25	1:1	6000	100Nm	P=30bar	X	-	-	109	-	-	-	-
MNL0020232	-	WELDON 32	1:1	6000	100Nm	P=30bar	X	-	-	125.5	-	-	-	-

TAKISAWA
MOD: TS3000/4000/5000 Y/YS 12 ST. (3 KEYS TURRET)

MODULO MOTORIZZATO RADIALE
Radial driven tool
Radial angetriebenes Werkzeug

Subject to change without notice.

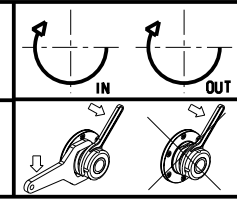

M.T. srl
Via Casino Albini 480
Tel. 0541/956034-957884
Fax 0541/956341
47842 S. GIOVANNI IN M. (RN)
e-mail: mtma@mtmarchetti.com
http://www.mtmarchetti.com

PRODUZIONE MODULI ROTANTI



PAGINA TKW 010-7-00

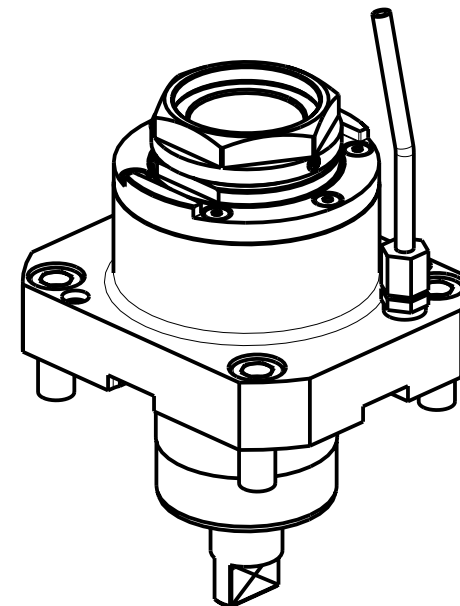
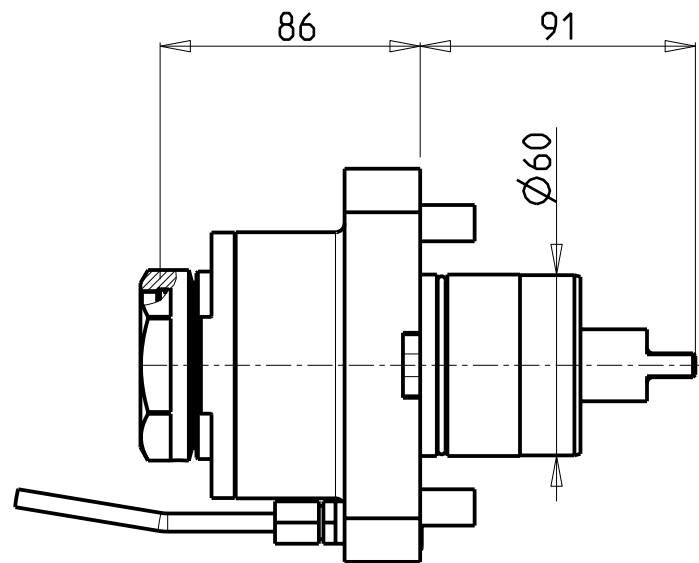
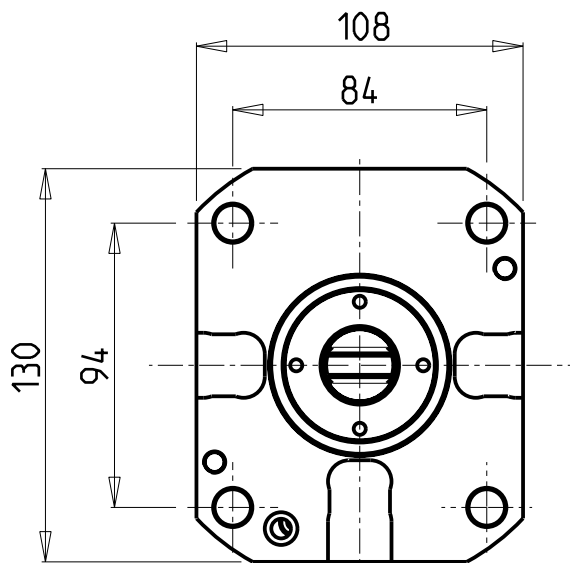

PER PORTAUTENSILI MODULARI MTSK-50 VEDI PAG. TBL300-1-50
 FOR MTSK-50 QUIK CHANGE TOOLHOLDERS CLAMPINGS SEE PAGE TBL300-1-50
 FUER MTSK-50 MODULARE WERKZEUGAUFNAHMEN SIEHE SEITE TBL300-1-50

- Chiave inclusa
- Key included
- Schluessel inbegriffen

Cod. MT	Mandrino Spindle Spindel	I	RPM	Coppia Max Max Torque Max Drehmoment	Lubrificazione est. Ext. coolant Aussenkuehlung	CHIAVI NON INCLUSE Keys not included Schluessel nicht einbegriffen	
MNL0590150	MTSK-50	1:1	6000	100Nm	X	CHUB55	OKU0430007 ▪

TAKISAWA
 MOD: TS3000/4000/5000 Y/YS 12 ST. (3 KEYS TURRET)

MODULO MOTORIZZATO RADIALE MTSK
 Radial MTSK driven tool
 Radial MTSK angetriebenes Werkzeug

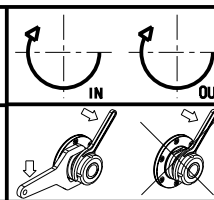

M.T. srl
 Via Casino Albini 480
 Tel. 0541/956034-957884
 Fax 0541/956341
 47842 S. GIOVANNI IN M. (RN)
 e-mail: mtma@mtmarchetti.com
 http://www.mtmarchetti.com

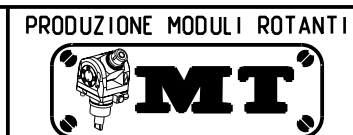

PAGINA TKW 010-7-00-K

Subject to change without notice.

10/2018

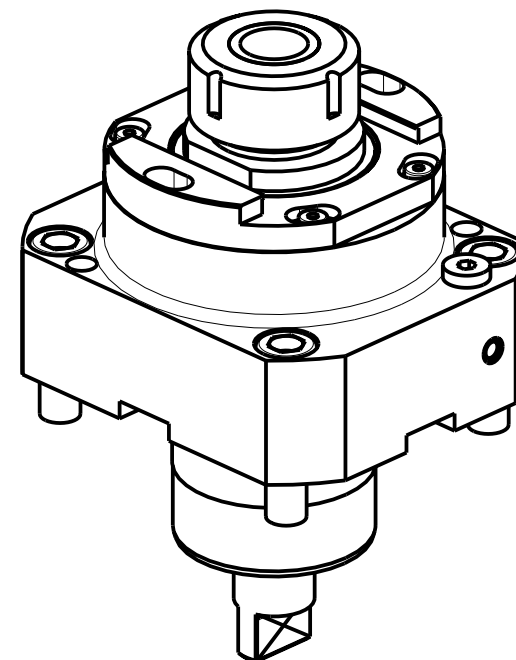
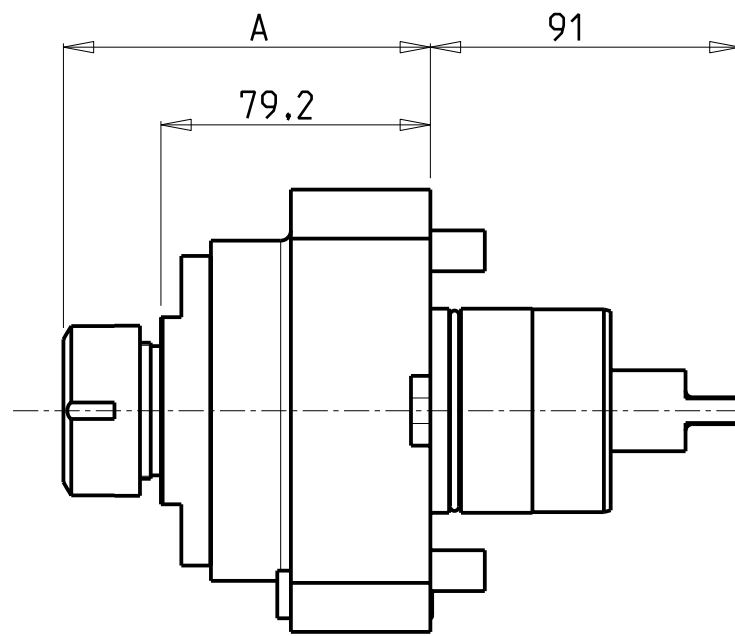
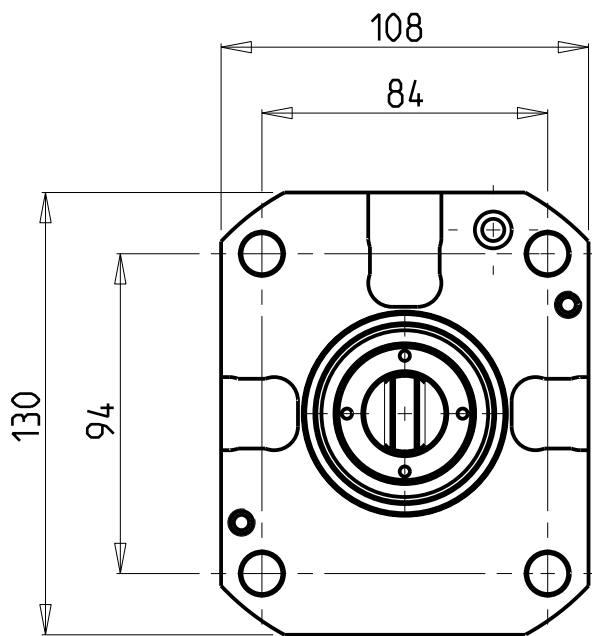

- Chiave inclusa
- Key included
- Schluessel inbegriffen

Cod. MT	Mandrino Spindle Spindel	I	RPM	Coppia Max Max Torque Max Drehmoment	Lubrificazione int. Coolant through Innenkuehlung	Lubrificazione est. Ext. coolant Aussenkuehlung	A	CHIAVI NON INCLUDE Keys not included Schluessel nicht einbegriffen	
MNL0570125	ER25	1:1	6000	100Nm	P=80bar	X	104.8	OKU0650004	CHSTER25
MNL0570132	ER32	1:1	6000	100Nm	P=80bar	X	107.8	OKU0650004	CHSTER32

TAKISAWA
 MOD: TS3000/4000/5000 Y/YS 12 ST. (3 KEYS TURRET)

MODULO MOTORIZZATO RADIALE ALTA PRESSIONE
 Radial driven tool high pressure
 Radial angetriebenes Werkzeug hochdruck

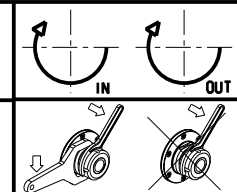

M.T. srl
 Via Casino Albini 480
 Tel. 0541/956034-957884
 Fax 0541/956341
 47842 S. GIOVANNI IN M. (RN)
 e-mail: mtma@mtmarchetti.com
 http://www.mtmarchetti.com

PRODUZIONE MODULI ROTANTI



PAGINA TKW 010-7-20

Subject to change without notice.

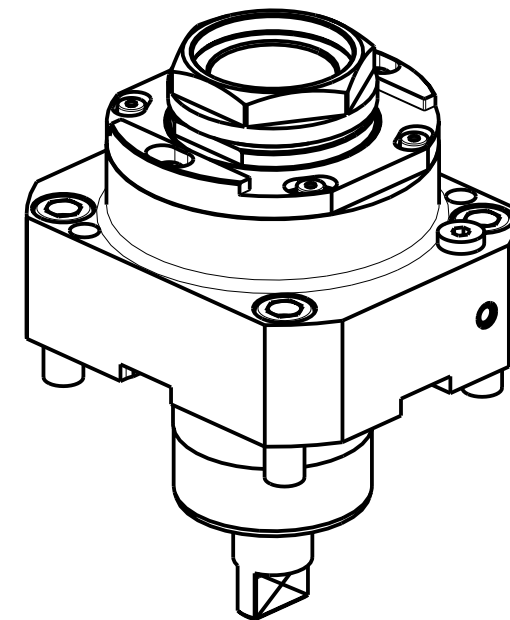
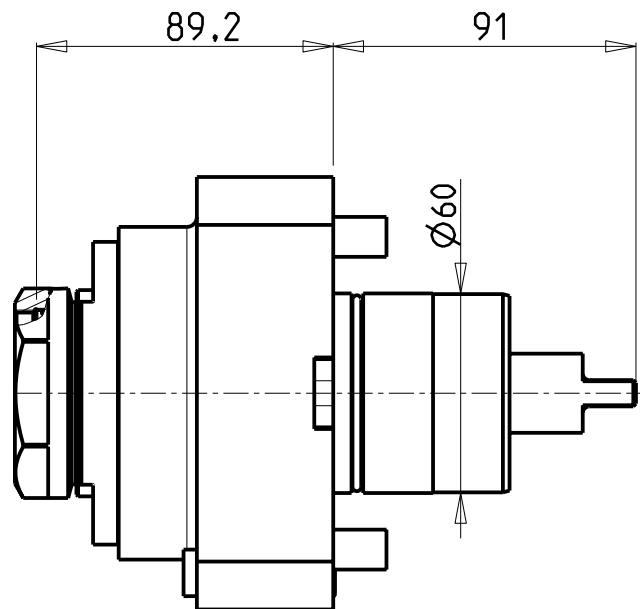
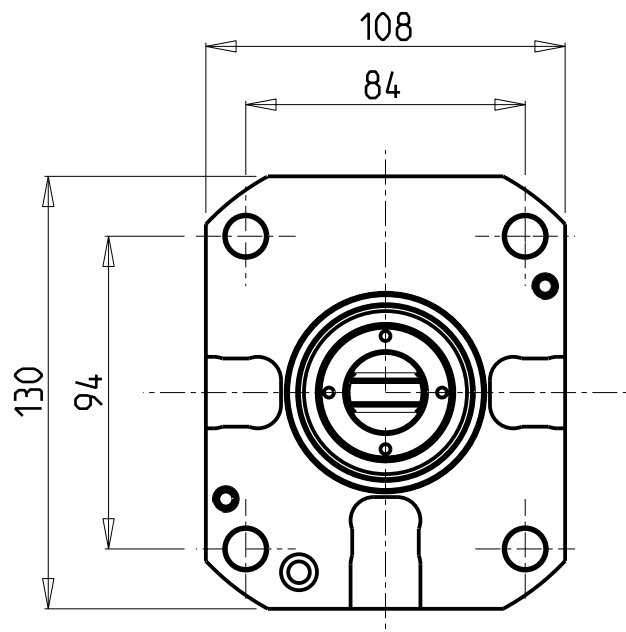

PER PORTAUTENSILI MODULARI MTSK-50 VEDI PAG. TBL300-1-50
 FOR MTSK-50 QUICK CHANGE TOOLHOLDERS CLAMPINGS SEE PAGE TBL300-1-50
 FUER MTSK-50 MODULARE WERKZEUGAUFNAHMEN SIEHE SEITE TBL300-1-50

- Chiave inclusa
- Key included
- Schlüssel inbegriffen

Cod. MT	Mandrino Spindle Spindel	I	RPM	Coppia Max Max Torque Max Drehmoment	Lubrificazione int. Coolant through Innenkuehlung	Lubrificazione est. Ext. coolant Aussenkuehlung	CHIAVI NON INCLUSE Keys not included Schlüssel nicht einbegriffen	
MNL0590250	MTSK-50	1:1	6000	100Nm	P=80bar	X	CHUB55	OKU0430007 ▪

TAKISAWA
 MOD: TS3000/4000/5000 Y/YS 12 ST. (3 KEYS TURRET)

MODULO MOTORIZZATO RADIALE MTSK ALTA PRESSIONE
 Radial MTSK driven tool high pressure
 Radial MTSK angetriebenes Werkzeug hochdruck

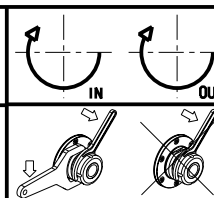

M.T. srl
 Via Casino Albini 480
 Tel. 0541/956034-957884
 Fax 0541/956341
 47842 S. GIOVANNI IN M. (RN)
 e-mail: mtma@mtmarchetti.com
 http://www.mtmarchetti.com

PRODUZIONE MODULI ROTANTI

PAGINA TKW 010-7-20-K

Subject to change without notice.

10/2018

CUSCINETTI MAGGIORATI PER LAVORAZIONI PESANTI

Reinforced bearings for
heavy machining

Vergroesserte Lager fuer
schwerere Bearbeitungen

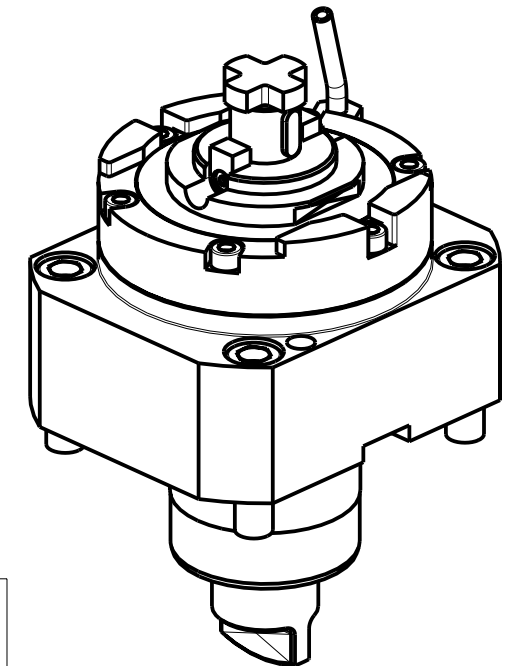
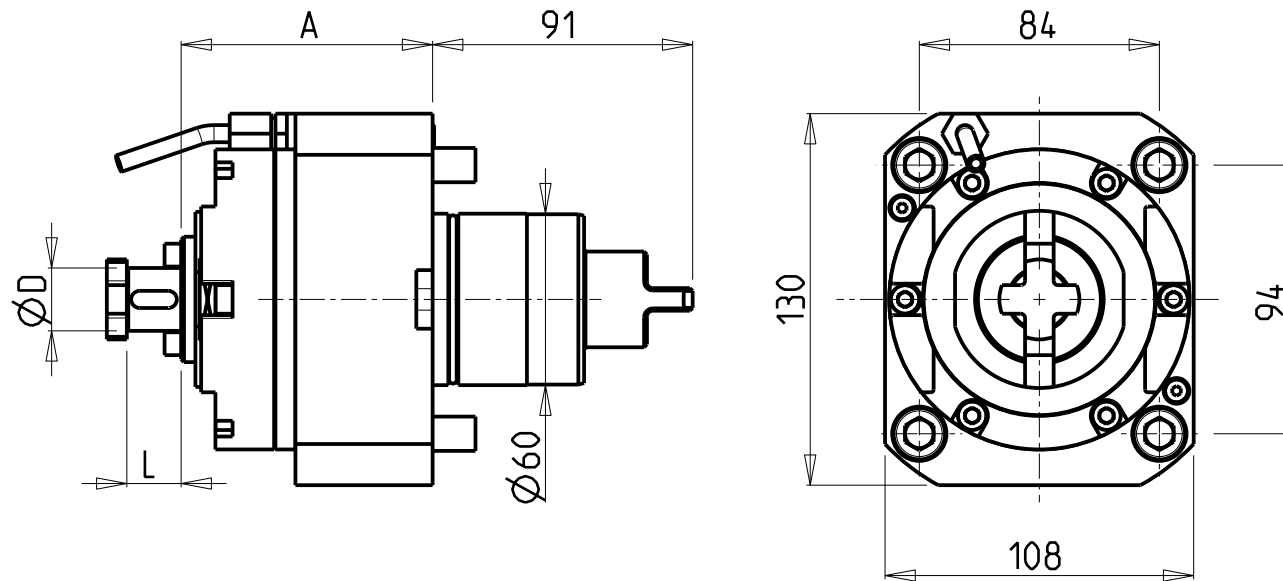

Cod. MT	Mandrino Spindle Spindel	I	RPM MAX	Coppia Max Max Torque Max Drehmoment	Lubrificazione est. Ext. coolant Auslenkuehlung	A	D	L	CHIAVI INCLUSE Keys included Schluessel inbegriffen	
MNL0732219	Ø22x19	1:1	4000	100Nm	X	88	22	19	CH_VTCROCE_M10	OKU0430007
MNL0732519	Ø1" x 19	1:1	4000	100Nm	X	89	1"	19	CH_VTCROCE_M12	OKU0430007
MNL0732721	Ø27x21	1:1	4000	100Nm	X	89	27	21	CH_VTCROCE_M12	OKU0430007
MNL0733224	Ø32x24	1:1	4000	100Nm	X	91	32	24	CH_VTCROCE_M16	OKU0430007

TAKISAWA

MOD: TS3000/4000/5000 Y/YS 12 ST. (3 KEYS TURRET)

MODULO MOTORIZZATO RADIALE MAGGIORATO

Radial reinforced driven tool

Radial angetriebenes Werkzeug vergroessert

Subject to change without notice.

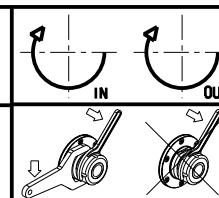

M.T. srl

Via Casino Albini 480
Tel. 0541/956034-957884
Fax 0541/956341
47842 S. GIOVANNI IN M. (RN)
e-mail: mtma@mtmarchetti.com
http://www.mtmarchetti.com

PRODUZIONE MODULI ROTANTI



PAGINA TKW020-7-00

**CUSCINETTI MAGGIORATI
PER LAVORAZIONI PESANTI**

Reinforced bearings for
heavy machining

Vergroesserte Lager fuer
schwerere Bearbeitungen

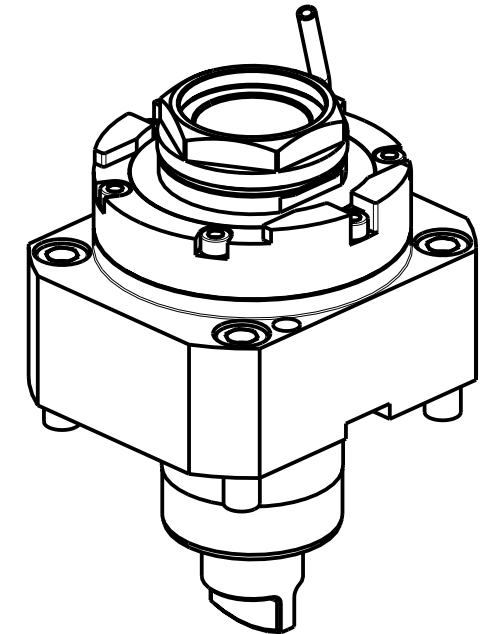
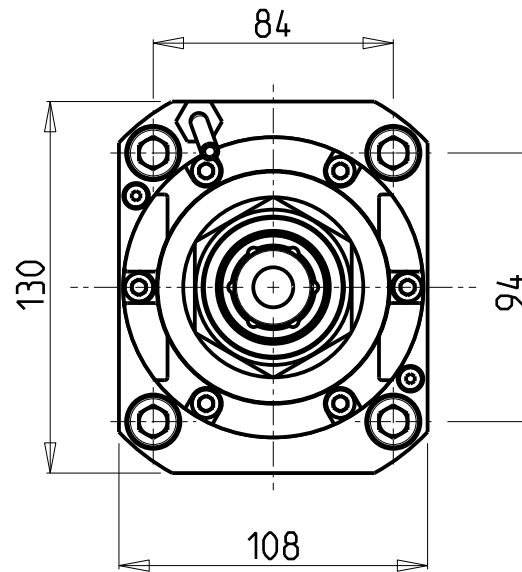
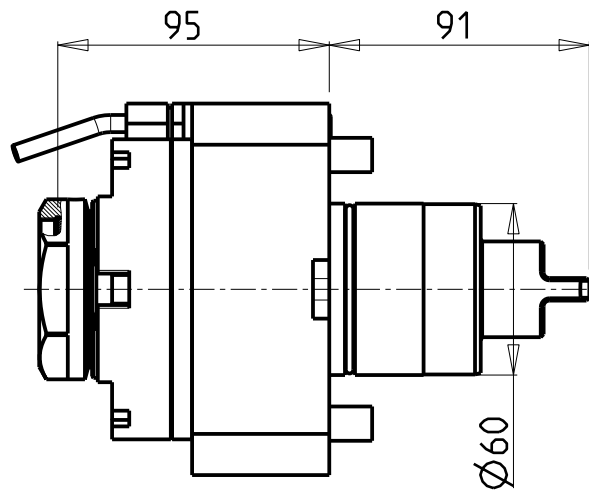

- Chiave inclusa
- Key included
- Schluessel inbegriffen

PER PORTAUTENSILI MODULARI MTSK-50 VEDI PAG. TBL300-1-50
FOR MTSK-50 QUIK CHANGE TOOLHOLDERS CLAMPINGS SEE PAGE TBL300-1-50
FUER MTSK-50 MODULARE WERKZEUGAUFNAHMEN SIEHE SEITE TBL300-1-50

Cod. MT	Mandrino Spindle Spindel	I	RPM MAX	Coppia Max Max Torque Max Drehmoment	Lubrificazione est. Ext. coolant Aussenkuehlung	CHIAVI NON INCLUSE Keys not included Schluessel nicht einbegriffen	
MNL0740150	MTSK-50	1:1	4000	100Nm	X	CHUB55	OKU0430007 *

TAKISAWA
MOD: TS3000/4000/5000 Y/YS 12 ST. (3 KEYS TURRET)

MODULO MOTORIZZATO RADIALE MAGGIORATO MTSK
Radial MTSK reinforced driven tool
Radial MTSK angetriebenes Werkzeug vergroessert

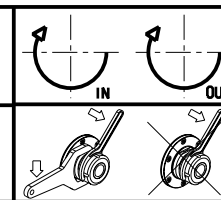

M.T. srl
Via Casino Albini 480
Tel. 0541/956034-957884
Fax 0541/956341
47842 S. GIOVANNI IN M. (RN)
e-mail: mtma@mtmarchetti.com
http://www.mtmarchetti.com

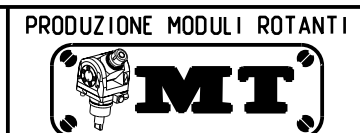

PAGINA TKW 020-7-00-K

Subject to change without notice.

10/2018

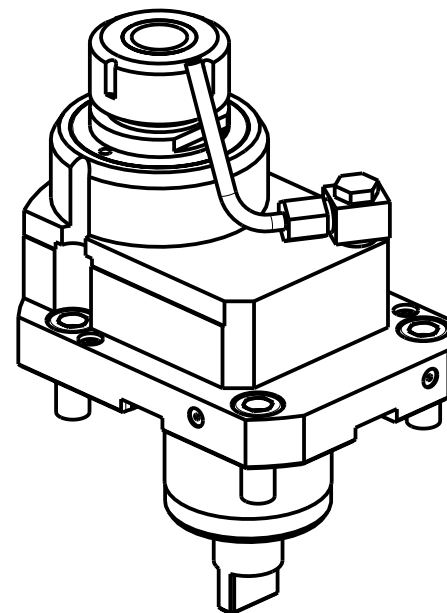
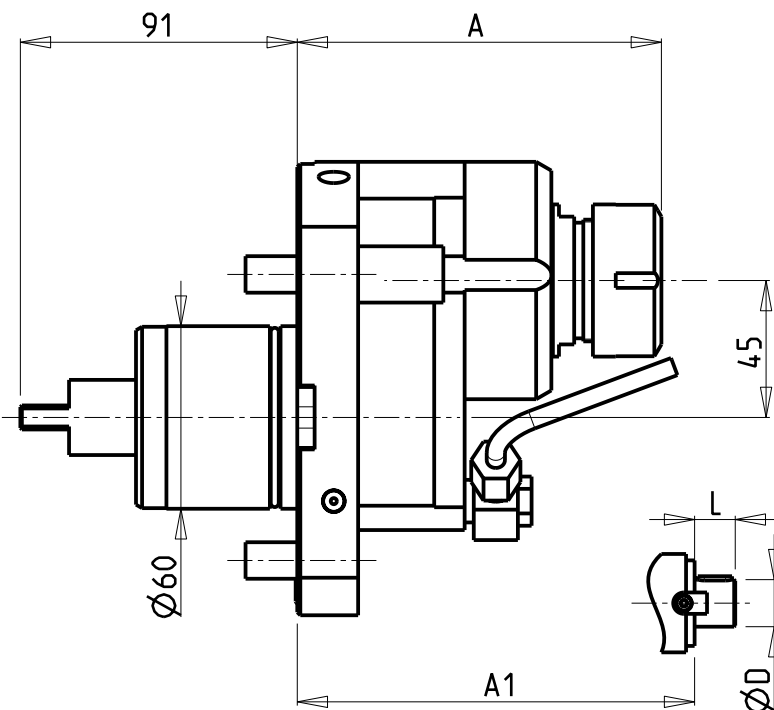
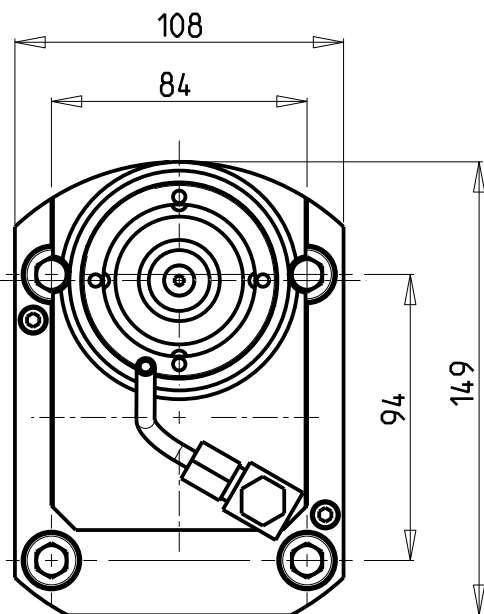

- Chiave inclusa
- Key included
- Schlüssel inbegriffen

Cod. MT	Mandrino Spindle Spindel	I	RPM	Coppia Max Max Torque Max Drehmoment	Reversibile lato mandrino/contromandrino Reversible sub/main spindle side Umkehrbare Spindel-seite/ Gegenspindel-seite	Lubr.esterna Ext. coolant Aussehenkuehlung	A	A1	D	L	CHIAVI NON INCLUDE Keys not included Schlüssel nicht einbegriffen	
MNL0342132	ER32	2:1	3000	100Nm	X	X	119.66	-	-	-	CHUB36	CHSTER32
MNL0342122	Ø22x19	2:1	3000	100Nm	X	X	-	98	22	19	CHUB36	CH_VTCROCE_M10 ▪
MNL0342127	Ø27x21	2:1	3000	100Nm	X	X	-	98	27	21	CHUB36	CH_VTCROCE_M12 ▪
MNL0342119	Ø3/4"x3/4"	2:1	3000	100Nm	X	X	-	98	3/4"	3/4"	CHUB36	CH_VTCROCE_M08 ▪
MNL0342125	Ø1"x19	2:1	3000	100Nm	X	X	-	98	1"	19	CHUB36	CH_VTCROCE_M12 ▪

TAKISAWA
 MOD: TS3000/4000/5000 Y/YS 12 ST. (3 KEYS TURRET)

MODULO MOTORIZZATO RADIALE RIDOTTO I=2:1 DISASSATO IN Z 45mm
 Radial geared-down I=2:1 driven tool re-directed in Z by 45mm
 Radial angetriebenes Werkzeug untersetzt I=2:1 achsversetzt in Z um 45mm

Subject to change without notice.

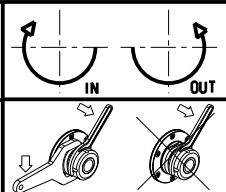

M.T. srl
 Via Casino Albini 480
 Tel. 0541/956034-957884
 Fax 0541/956341
 47842 S. GIOVANNI IN M. (RN)
 e-mail: mtma@mtmarchetti.com
 http://www.mtmarchetti.com

PRODUZIONE MODULI ROTANTI



PAGINA TKW030-7-20

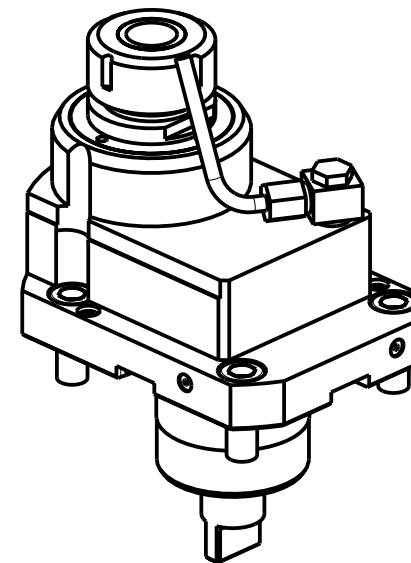
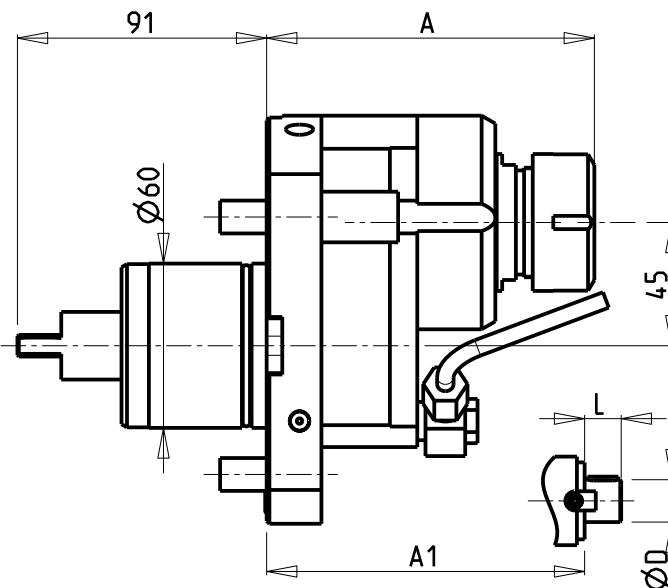
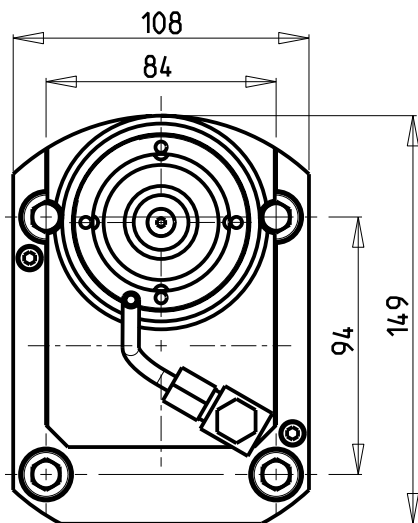

- Chiave inclusa
- Key included
- Schluessel inbegriffen

Cod. MT	Mandrino Spindle Spindel	I	RPM	Coppia Max Max Torque Max Drehmoment	Reversibile lato mandrino/contromandrino Reversible sub/main spindle side Umkehrbare Spindel-seite/ Gegenspindel-seite	Lubrificazione int. Coolant through Innenkuehlung	Lubr. esterna Ext. coolant Aussenkuehlung	A	A1	D	L	CHIAVI NON INCLUDE Keys not included Schluessel nicht inbegriffen	
MNL0340120	ER20	1:1	6000	100Nm	X	-	X	115.66	-	-	-	CHUB42	CHSTER20
MNL0340032	ER32	1:1	6000	100Nm	X	-	X	119.66	-	-	-	CHUB42	CHSTER32
MNL0340220	ER20	1:1	6000	100Nm	X	P=70bar	X	126.66	-	-	-	CHUB42	CHSTER20
MNL0340132	ER32	1:1	6000	100Nm	X	P=70bar	X	131.16	-	-	-	CHUB42	CHSTER32
MNL0341116	Ø16x17	1:1	6000	100Nm	X	-	X	-	98	16	17	CHUB42	CH_VTCROCE_M08 *
MNL0341122	Ø22x19	1:1	6000	100Nm	X	-	X	-	98	22	19	CHUB42	CH_VTCROCE_M10 *
MNL0341127	Ø27x21	1:1	6000	100Nm	X	-	X	-	98	27	21	CHUB42	CH_VTCROCE_M12 *
MNL0341119	Ø3/4"x3/4"	1:1	6000	100Nm	X	-	X	-	98	3/4"	3/4"	CHUB42	CH_VTCROCE_M08 *
MNL0342225	Ø1"x19	1:1	6000	100Nm	X	-	X	-	98	1"	19	CHUB42	CH_VTCROCE_M12 *

TAKISAWA
 MOD: TS3000/4000/5000 Y/YS 12 ST. (3 KEYS TURRET)

MODULO MOTORIZZATO RADIALE DISASSATO IN Z 45mm
 Radial driven tool re-directed in Z by 45mm
 Radial angetriebenes Werkzeug achsversetzt in Z um 45mm

Subject to change without notice.

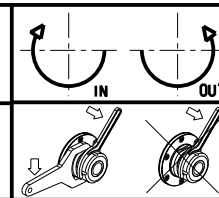

M.T. srl
 Via Casino Albini 480
 Tel. 0541/956034-957884
 Fax 0541/956341
 47842 S. GIOVANNI IN M. (RN)
 e-mail: mtma@mtmarchetti.com
 http://www.mtmarchetti.com

PRODUZIONE MODULI ROTANTI



PAGINA TKW033-7-10

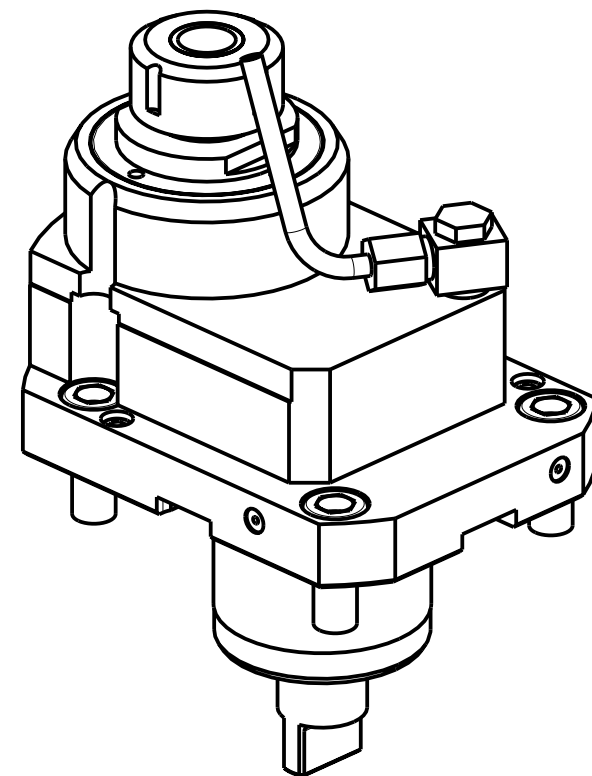
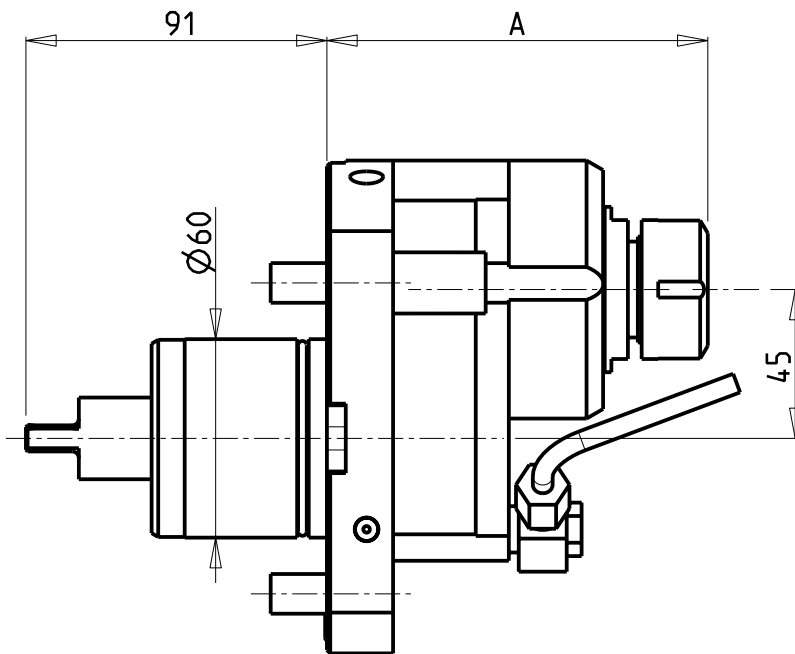
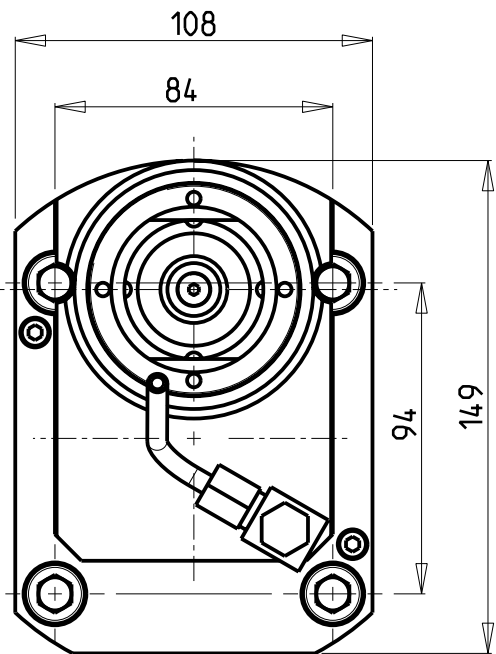

Cod. MT	Mandrino Spindle Spindel	I	RPM MAX	Coppia Max Max Torque Max Drehmoment	Reversibile lato mandrino/contromandrino Reversible sub/main spindle side Umkehrbare Spindel-seite/ Gegenspindel-seite	Lubrificazione int. Coolant through Innenkuehlung	Lubrificazione est. Ext. coolant Aussenkuehlung	A	CHIAVI NON INCLUSE Keys not included Schlüssel nicht einbegriffen	
MNL0341225	ER25	1:2	12000	40Nm	X		X	115.16	CHUB42	CHSTER25
MNL0342425	ER25	1:2	10000	40Nm	X	P=70bar	X	126.16	CHUB42	CHSTER25

TAKISAWA

MOD: TS3000/4000/5000 Y/YS 12 ST. (3 KEYS TURRET)

MODULO MOTORIZZATO RADIALE MOLTIPLICATO I=1:2 DISASSATO IN Z 45mm

Radial geared-up I=1:2 driven tool re-directed in Z by 45mm

Radial angetriebenes Werkzeug uebersetzt I=1:2 achsversetzt in Z um 45mm

Subject to change without notice.

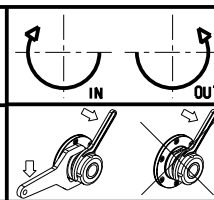

M.T. srl

Via Casino Albini 480
Tel. 0541/956034-957884
Fax 0541/956341

47842 S. GIOVANNI IN M. (RN)
e-mail: mtma@tmarchetti.com
http://www.tmarchetti.com

PRODUZIONE MODULI ROTANTI



PAGINA TKW033-7-30

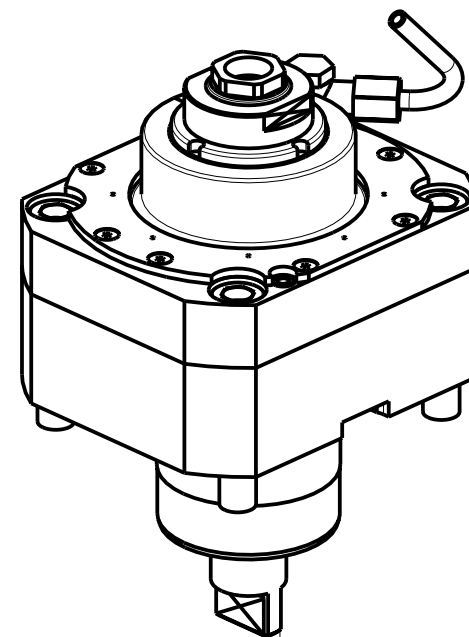
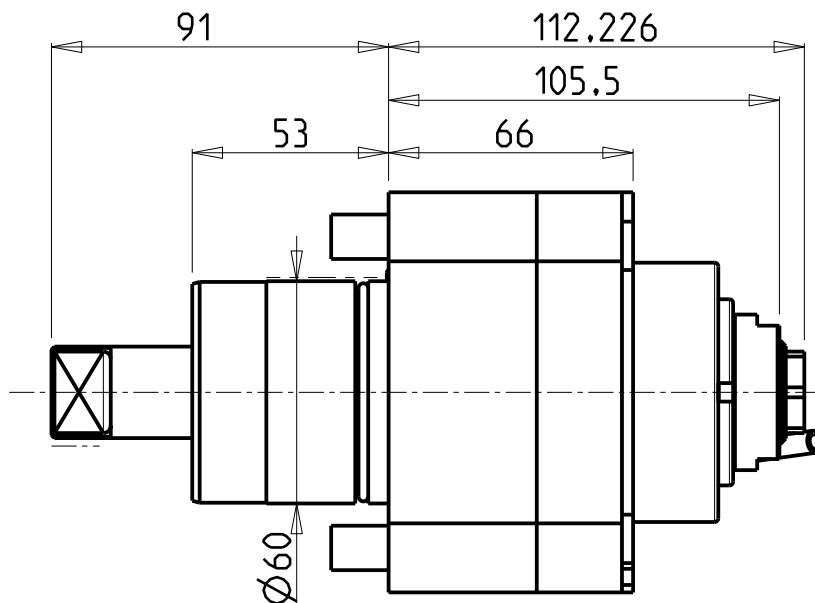
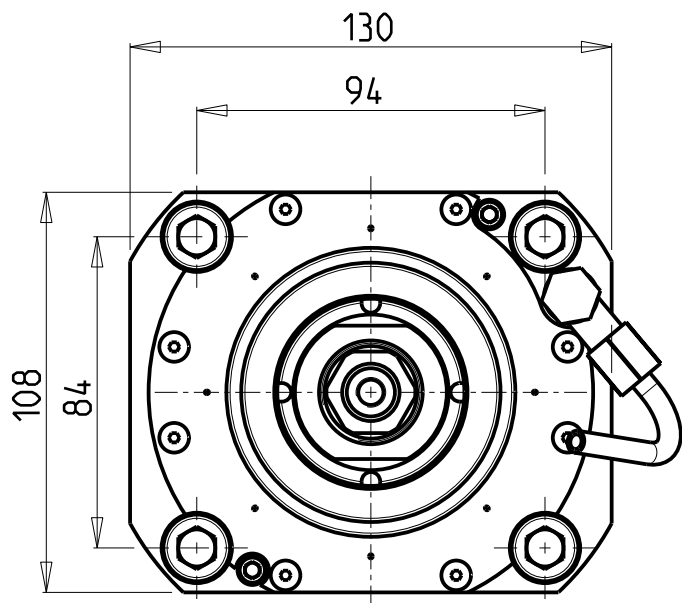

ATTENZIONE - ATTENTION - ACHTUNG

- PRIMA DI UTILIZZARE IL MOTORIZZATO CONSULTARE LE ISTRUZIONI ALLEGATE!
- BEFORE USING THE DRIVEN TOOL, PLEASE CHECK THE ENCLOSED INSTRUCTION SHEET!
- VOR DER BENUTZUNG DES ANGETRIEBENEN WERKZEUGES, DIE BEILIEGENDEN INSTRUKTIONEN DURCHLESEN!

ATTENZIONE - ATTENTION - ACHTUNG

- Per lo smontaggio degli utensili utilizzare sempre la chiave di contrasto come indicato nel manuale d'uso.
- For disassembly of the tools use always the contrast key as mentioned in the user instructions.
- Fuer das Abmontieren der Werkzeuge immer den Gegenschlüssel benutzen wie in der Bedienungsanleitung erwaeht.

Cod. MT	Mandrino Spindle Spindel	i	RPM	Coppia Max Max Torque Max Drehmoment	Lubrificazione est. Ext. coolant Aussenkuehlung	CHIAVI INCLUSE Keys included Schluessel einbegriffen	
						CHUB36	CHUB22
MNL0690120	ERA20	1:5	30000	15Nm	X	CHUB36	CHUB22

TAKISAWA

MOD: TS3000/4000/5000 Y/YS 12 ST. (3 KEYS TURRET)

MODULO MOTORIZZATO RADIALE Moltiplicato I=1:5

Radial geared-up I=1:5 driven tool

Radial angetriebenes Werkzeug uebersetzt I=1:5

Subject to change without notice.

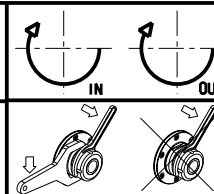

M.T. srl

Via Casino Albini 480
Tel. 0541/956034-957884

Fax 0541/956341

47842 S. GIOVANNI IN M. (RN)

e-mail: mtma@mtmarchetti.com

http://www.mtmarchetti.com

PRODUZIONE MODULI ROTANTI



PAGINA TKW059-7-00

ATTENZIONE - ATTENTION - ACHTUNG

- Per lo smontaggio degli utensili utilizzare sempre la chiave di contrasto come indicato nel manuale d'uso.
- For disassembly of the tools use always the contrast key as mentioned in the user instructions.
- Fuer das Abmontieren der Werkzeuge immer den Gegenschlüssel benutzen wie in der Bedienungsanleitung erwaeht.

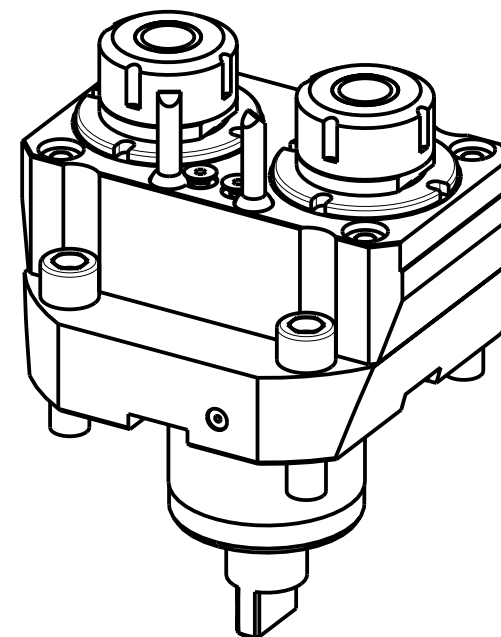
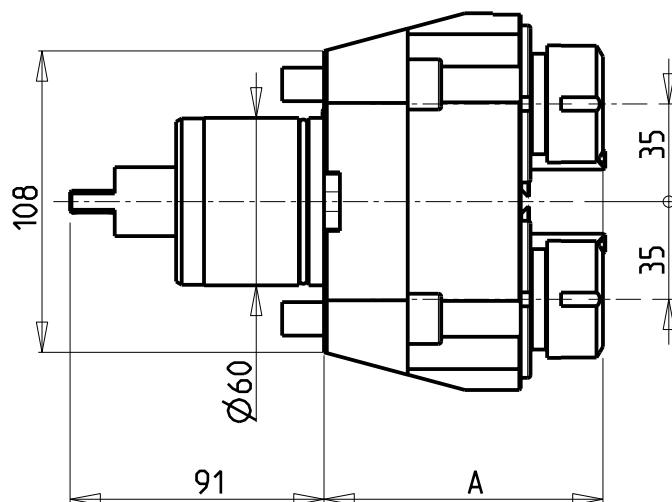
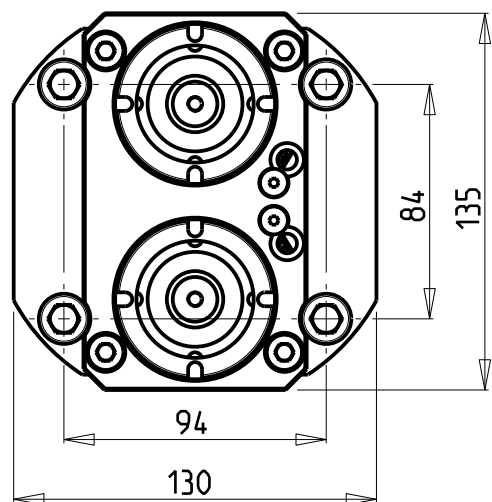

MNL0201325

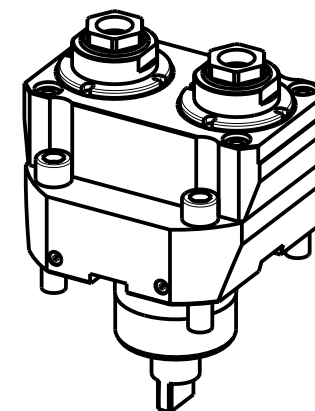

Cod. MT	Mandrino Spindle Spindel	I	RPM	Coppia Max Max Torque Max Drehmoment	Lubrificazione int. Coolant through Innenkuehlung	Lubrificazione est. Ext. coolant Aussenkuehlung	A	CHIAVI NON INCLUSE Keys not included Schlüssel nicht einbegriffen	
MNL0200225	ER25	1:1	6000	40Nm		X	99.96	CHUB36	CHSTER25
MNL0201225	ER25	1:1	6000	40Nm	P=70bar	X	115.2	CHUB36	CHSTER25
MNL0201325	ER A 25	1:1	6000	40Nm	P=70bar	X	108.53	CHUB38	CHUB27

TAKISAWA

MOD: TS3000/4000/5000 Y/YS 12 ST. (3 KEYS TURRET)

MODULO MOTORIZZATO RADIALE 2 USCITE IN Y

Radial single side twin head driven tool in Y

Radial angetriebenes Werkzeug 2 Ausgaenge in Y

Subject to change without notice.

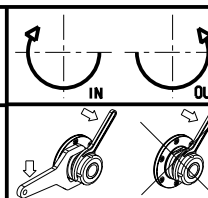

M.T. srl

Via Casino Albini 480
Tel. 0541/956034-957884
Fax 0541/956341
47842 S. GIOVANNI IN M. (RN)
e-mail: mtma@mtmarchetti.com
http://www.mtmarchetti.com

PRODUZIONE MODULI ROTANTI



PAGINA TKW080-7-00

ATTENZIONE - ATTENTION - ACHTUNG

- Per lo smontaggio degli utensili utilizzare sempre la chiave di contrasto come indicato nel manuale d'uso.
- For disassembly of the tools use always the contrast key as mentioned in the user instructions.
- Fuer das Abmontieren der Werkzeuge immer den Gegenschlüssel benutzen wie in der Bedienungsanleitung erwaeht.

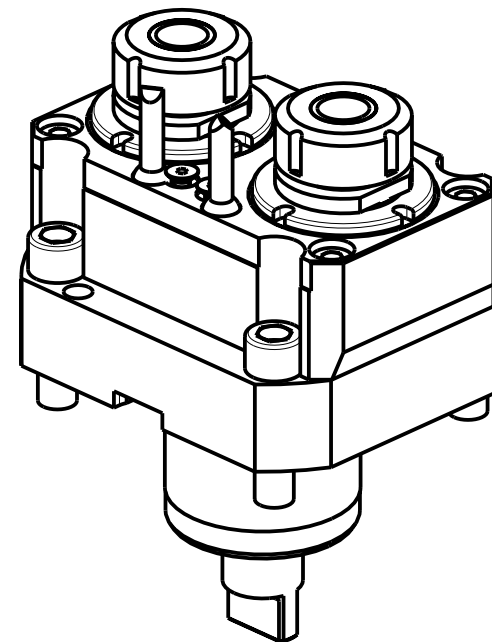
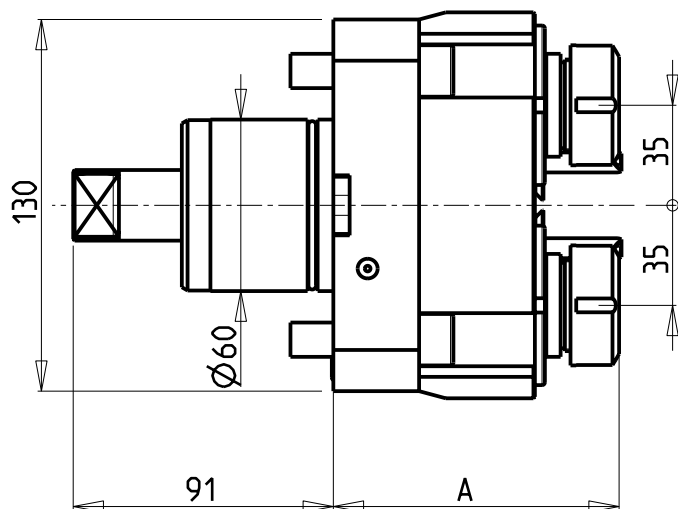
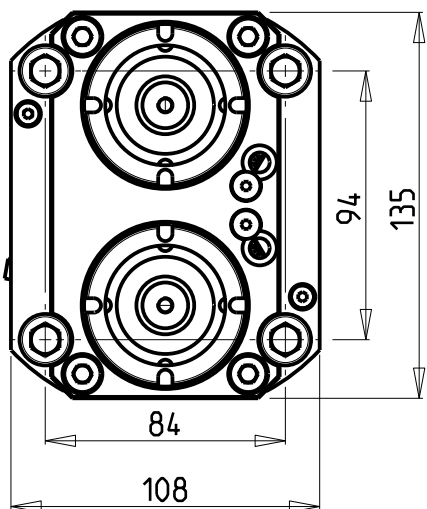

MNL0421325

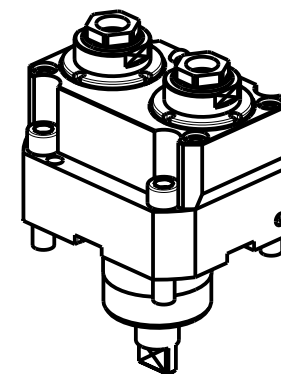

Cod. MT	Mandrino Spindle Spindel	I	RPM	Coppia Max Max Torque Max Drehmoment	Lubrificazione int. Coolant through Innenkuehlung	Lubrificazione est. Ext. coolant Aussenkuehlung	A	CHIAVI NON INCLUSE Keys not included Schluesssel nicht einbegriffen	
MNL0420225	ER25	1:1	6000	40Nm		X	99.96	CHUB36	CHSTER25
MNL0421225	ER25	1:1	6000	40Nm	P=70bar	X	115.2	CHUB36	CHSTER25
MNL0421325	ER A 25	1:1	6000	40Nm	P=70bar	X	108.53	CHUB38	CHUB27

TAKISAWA

MOD: TS3000/4000/5000 Y/YS 12 ST. (3 KEYS TURRET)

MODULO MOTORIZZATO RADIALE 2 USCITE IN Z
Radial single side twin head driven tool in Z
Radial angetriebenes Werkzeug 2 Ausgaenge in Z

Subject to change without notice.

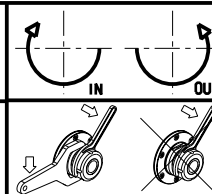

M.T. srl

Via Casino Albini 480
Tel. 0541/956034-957884
Fax 0541/956341
47842 S. GIOVANNI IN M. (RN)
e-mail: mtma@mtmarchetti.com
http://www.mtmarchetti.com

PRODUZIONE MODULI ROTANTI



PAGINA TKW090-7-00

ATTENZIONE - ATTENTION - ACHTUNG

- Per lo smontaggio degli utensili utilizzare sempre la chiave di contrasto come indicato nel manuale d'uso.
- For disassembly of the tools use always the contrast key as mentioned in the user instructions.
- Fuer das Abmontieren der Werkzeuge immer den Gegenschlüssel benutzen wie in der Bedienungsanleitung erwaehnt.

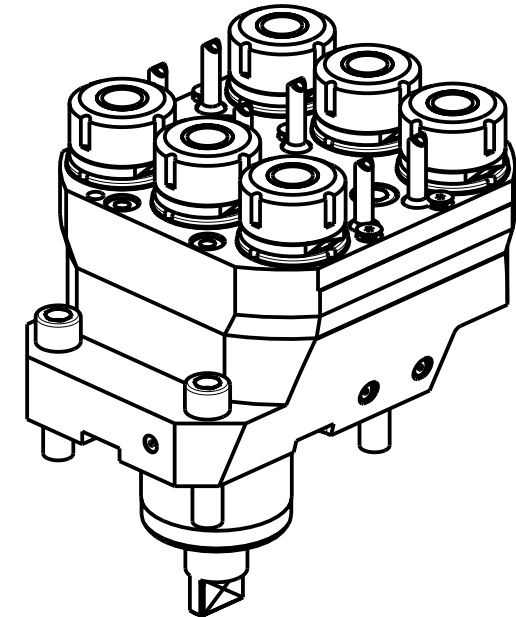
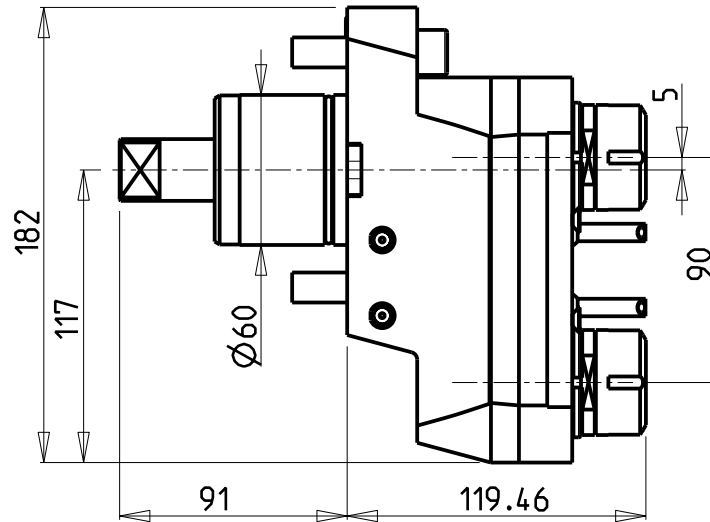
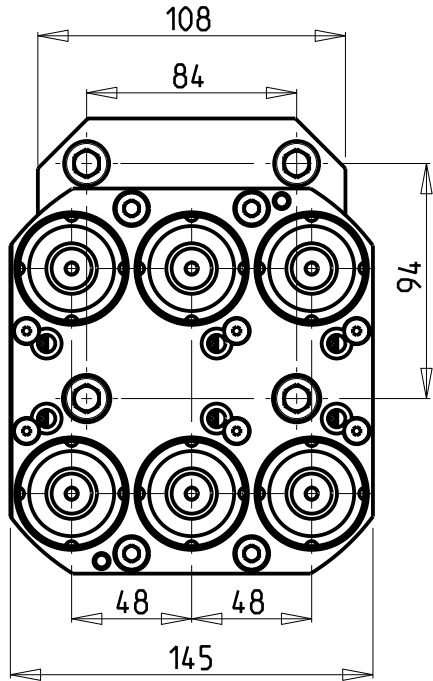

Cod. MT	Mandrino Spindle Spindel	I	RPM	Coppia Max Max Torque Max Drehmoment	N°Utensili N°Tools N°Werkzeuge	Reversibile lato mandrino/contromandrino Reversible sub/main spindle side Umkehrbare Spindel-seite/ Gegenspindel-seite	Lubrificazione est. Ext. coolant Aussenkuehlung	CHIAVI INCLUSE Keys included Schluesssel inbegriffen
MNL0210625	ER25	1:1	6000	20Nm	6	X	X	MNL0210007 MNL0210008

TAKISAWA
 MOD: TS3000/4000/5000 Y/YS 12 ST. (3 KEYS TURRET)

MODULO MOTORIZZATO RADIALE 6 USCITE
 Radial 6 head driven tool
 Radial angetriebenes Werkzeug 6 Ausgaenge

Subject to change without notice.

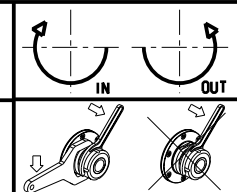

M.T. srl
 Via Casino Albini 480
 Tel. 0541/956034-957884
 Fax 0541/956341
 47842 S. GIOVANNI IN M. (RN)
 e-mail: mtma@mtmarchetti.com
 http://www.mtmarchetti.com

PRODUZIONE MODULI ROTANTI



PAGINA TKW 110-7-00

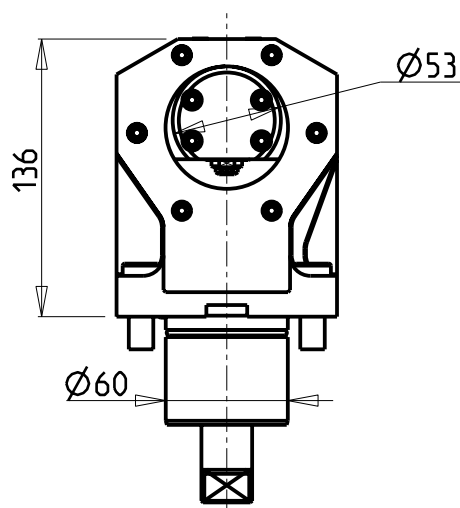
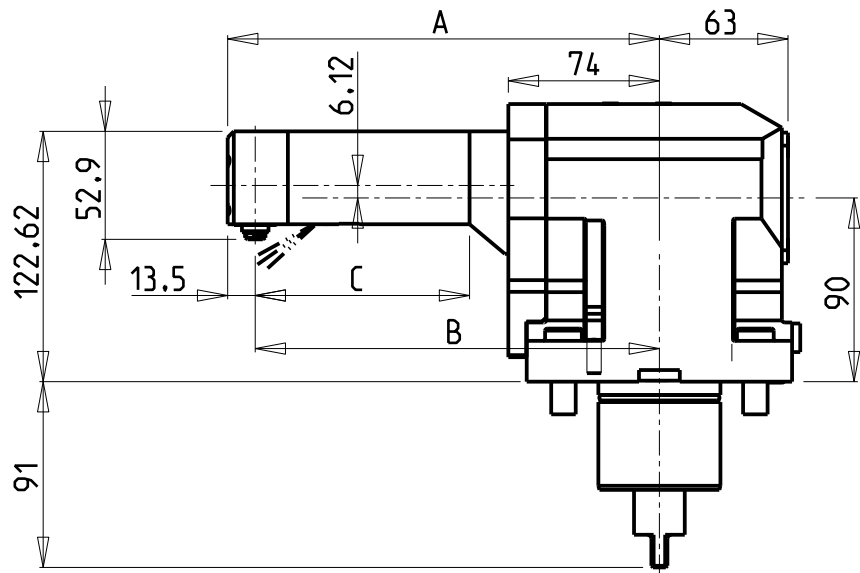
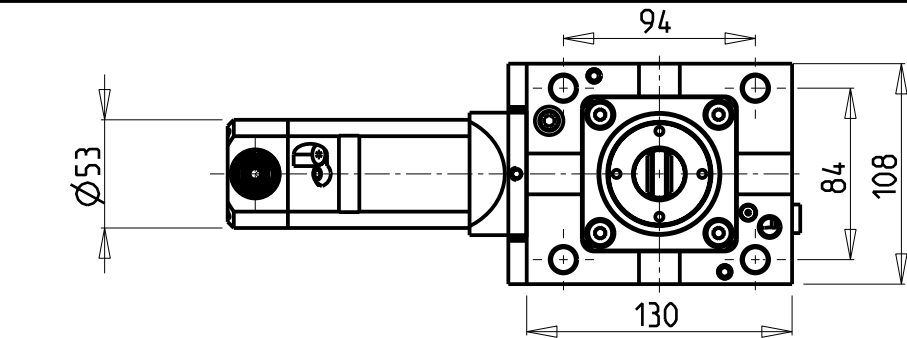

PER LAVORAZIONI INTERNE
SU FORI Ø60 MINIMO

For machining internal
holes with Ø60 min. hole

Fuer interne Bearbeitungen
am Loch minimum Ø60

ATTENZIONE - ATTENTION - ACHTUNG

- Per lo smontaggio degli utensili utilizzare sempre la chiave di contrasto come indicato nel manuale d'uso.
- For disassembly of the tools use always the contrast key as mentioned in the user instructions.
- Fuer das Abmontieren der Werkzeuge immer den Gegenschlüssel benutzen wie in der Bedienungsanleitung erwäehnt.

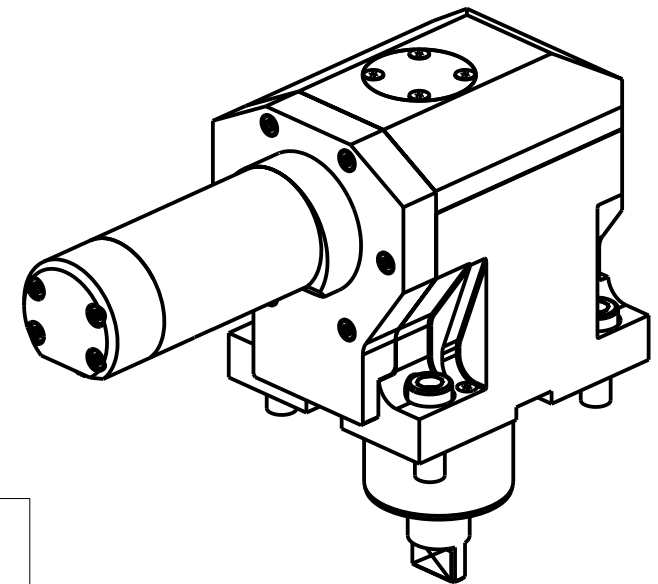

Cod. MT	Mandrino Spindle Spindel	I	RPM	Coppia Max Max Torque Max Drehmoment	Lubrificazione est. Ext. coolant Aussenkuehlung	A	B	C	CHIAVI INCLUSE Keys included Schluessel einbegriffen	
MNL0961055	CHG	1:1	6000	8Nm	X	161.5	148	55	CHUB13	CHCHG10
MNL0961105	CHG	1:1	6000	8Nm	X	211.5	198	105	CHUB13	CHCHG10
MNL0961155	CHG	1:1	6000	8Nm	X	261.5	248	155	CHUB13	CHCHG10

TAKISAWA

MOD: TS3000/4000/5000 Y/YS 12 ST. (3 KEYS TURRET)

MODULO MOTORIZZATO RADIALE ROVESCIAIO DISASSATO IN Z

Radial inverted driven tool re-directed in Z

Radial angetriebenes Werkzeug ungekehrt achsversetzt in Z

Subject to change without notice.

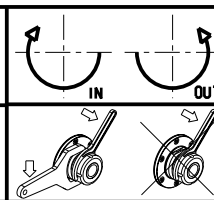

M.T. srl

Via Casino Albini 480
Tel. 0541/956034-957884
Fax 0541/956341
47842 S. GIOVANNI IN M. (RN)
e-mail: mtma@mtmarchetti.com
http://www.mtmarchetti.com

PRODUZIONE MODULI ROTANTI



PAGINA TKW 120-7-30

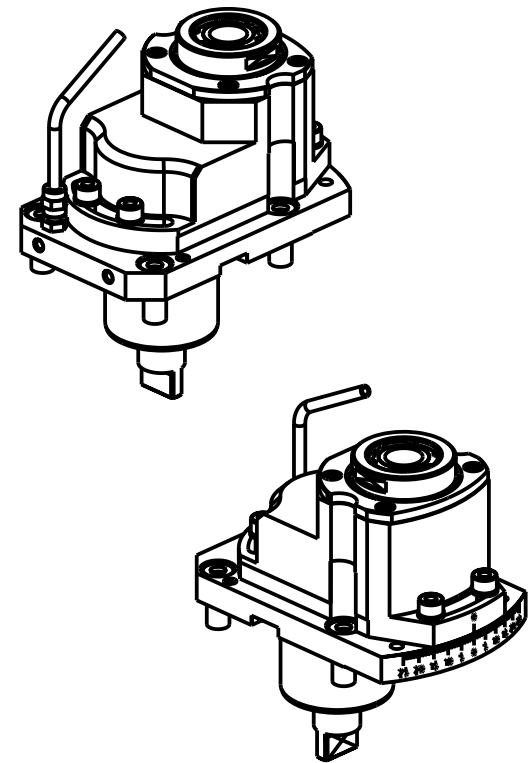
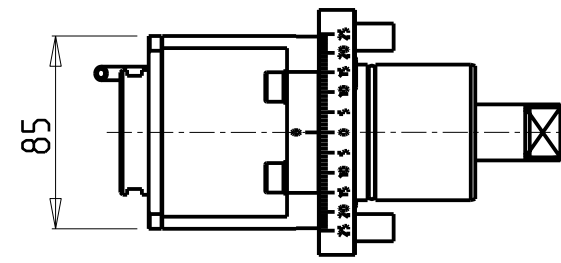
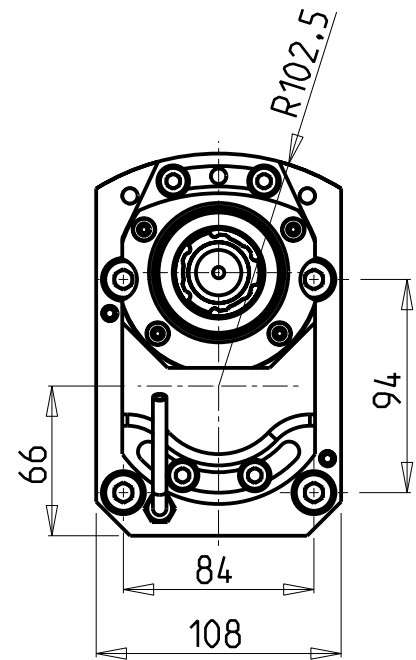
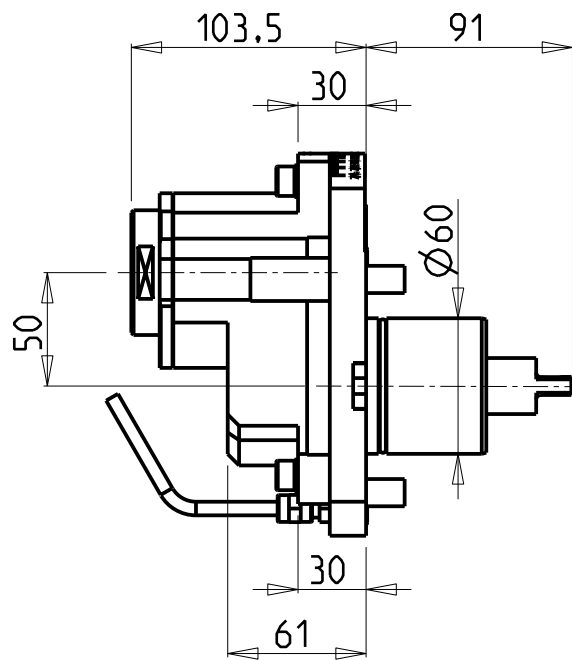

ATTENZIONE - ATTENTION - ACHTUNG

- Per lo smontaggio degli utensili utilizzare sempre la chiave di contrasto come indicato nel manuale d'uso.
- For disassembly of the tools use always the contrast key as mentioned in the user instructions.
- Fuer das Abmontieren der Werkzeuge immer den Gegenschlüssel benutzen wie in der Bedienungsanleitung erwaeht.

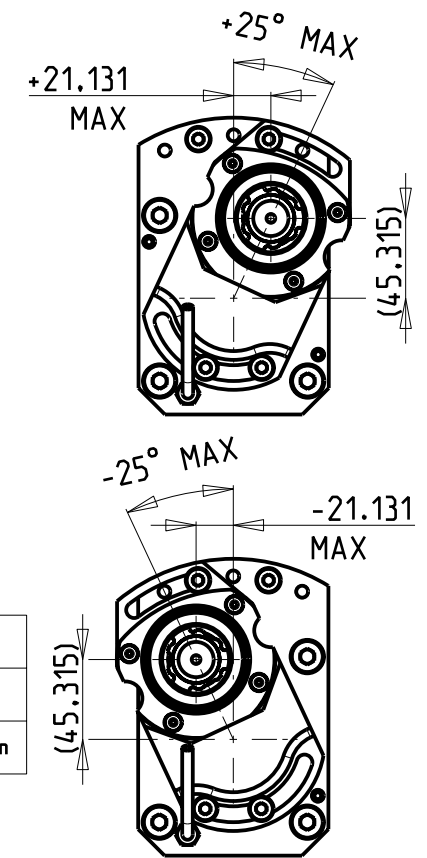

- Chiave inclusa
- Key included
- Schlüssel inbegriffen

Cod. MT	Mandrino Spindle Spindel	I	RPM	Coppia Max Max Torque Max Drehmoment	Reversibile lato mandrino/contromandrino Reversible sub/main spindle side Umkehrbare Spindelseite/ Gegenspindelseite	Lubrificazione est. Ext. coolant Aussenkuehlung	CHIAVI NON INCLUSE Keys not included Schluessel nicht einbegriffen		
MNL0950332	ERA32	1:1	6000	100Nm	X	X	CHUB30	CHUB50	CHTAER32ZC

TAKISAWA
 MOD: TS3000/4000/5000 Y/YS 12 ST. (3 KEYS TURRET)
 MODULO MOTORIZZATO RADIALE DISASSATO 50mm ORIENTABILE ±25°
 Radial ±25° adjustable angle driven tool re-directed by 50mm
 Radial angetriebenes Werkzeug schwenkbar ±25° achsversetzt um 50mm
 Subject to change without notice.

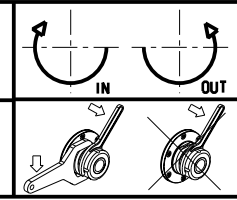

M.T. srl
 Via Casino Albini 480
 Tel. 0541/956034-957884
 Fax 0541/956341
 47842 S. GIOVANNI IN M. (RN)
 e-mail: mtma@mtmarchetti.com
 http://www.mtmarchetti.com

PRODUZIONE MODULI ROTANTI

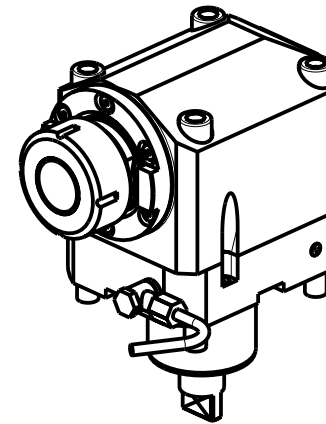
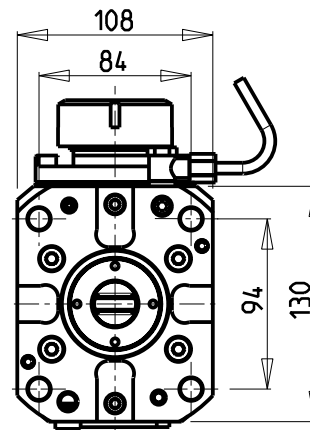
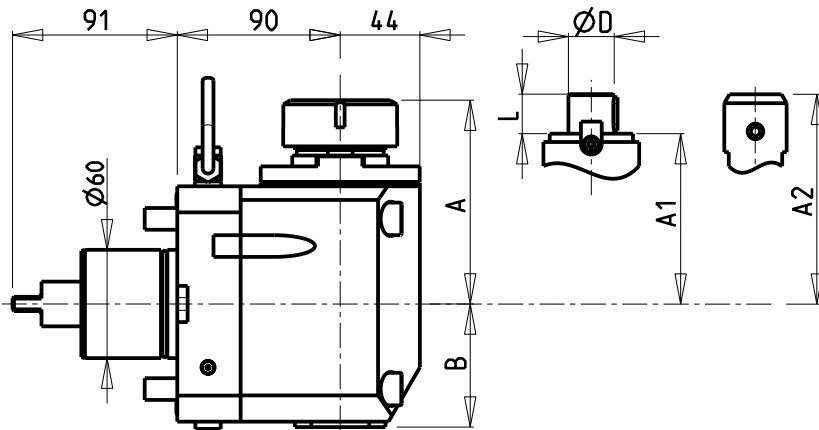
 PAGINA TKW 135-7-00



- Chiave inclusa
- Key included
- Schlüssel inbegriffen

Cod. MT	Cod. MORI-SEIKI	Mandrino Spindle Spindel	I	RPM	Coppia Max Max Torque Max Drehmoment	Reversibile lato mandrino/contromandrino Reversible sub/main spindle side Umkehrbare Spindel-seite/ Gegenspindel-seite	Lubr.interna Coolant through Innenkuehlung	Lubr.esterna Ext. coolant Aussenkuehlung	A	A1	A2	B	D	L	CHIAVI NON INCLUDE Keys not included Schluessel nicht einbegriffen	
MNL0010525	-	ER25	1:1	6000	100Nm	X	-	X	107.6	-	-	69	-	-	OKU0650004	CHSTER25
MNL0010532	T32207	ER32	1:1	6000	100Nm	X	-	X	110.6	-	-	69	-	-	OKU0650004	CHSTER32
MNL0010140	T32214	ER40	1:1	6000	100Nm	X	-	X	112.6	-	-	69	-	-	OKU0650004	CHSTER40
MNL0010325	-	ER A 32	1:1	6000	100Nm	X	-	X	98.5	-	-	69	-	-	OKU0650004	CHUB32
MNL0011525	-	ER25	1:1	6000	100Nm	X	P=70bar	X	107.6	-	-	79	-	-	OKU0650004	CHSTER25
MNL0011532	-	ER32	1:1	6000	100Nm	X	P=70bar	X	110.6	-	-	79	-	-	OKU0650004	CHSTER32
MNL0011140	-	ER40	1:1	6000	100Nm	X	P=70bar	X	112.6	-	-	79	-	-	OKU0650004	CHSTER40
MNL0010432	-	ER A 32	1:1	6000	100Nm	X	P=70bar	X	98.5	-	-	79	-	-	OKU0650004	CHUB32
MNL0011617	-	Ø16x17	1:1	6000	100Nm	X	-	X	-	87.5	-	69	16	17	OKU0650004	CH_VTCROCE_M08
MNL0012219	-	Ø22x19	1:1	6000	100Nm	X	-	X	-	87.5	-	69	22	19	OKU0650004	CH_VTCROCE_M10
MNL0012721	-	Ø27x21	1:1	6000	100Nm	X	-	X	-	87.5	-	69	27	21	OKU0650004	CH_VTCROCE_M12
MNL0012519	-	Ø1"x19	1:1	6000	100Nm	X	-	X	-	87.5	-	69	1"	19	OKU0650004	CH_VTCROCE_M12
MNL0010120	-	WELDON 20	1:1	6000	100Nm	X	-	X	-	-	105.5	69	-	-	-	-
MNL0010125	-	WELDON 25	1:1	6000	100Nm	X	-	X	-	-	115	69	-	-	-	-
MNL0010132	-	WELDON 32	1:1	6000	100Nm	X	-	X	-	-	131.5	69	-	-	-	-
MNL0010220	-	WELDON 20	1:1	6000	100Nm	X	P=70bar	X	-	-	105.5	91.5	-	-	-	-
MNL0010225	-	WELDON 25	1:1	6000	100Nm	X	P=70bar	X	-	-	115	91.5	-	-	-	-

TAKISAWA
 MOD: TS3000/4000/5000 Y/YS 12 ST. (3 KEYS TURRET)

MODULO MOTORIZZATO ASSIALE
 Axial driven tool
 Axial angetriebenes Werkzeug

Subject to change without notice.

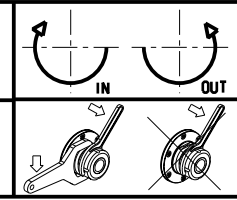

M.T. srl
 Via Casino Albini 480
 Tel. 0541/956034-957884
 Fax 0541/956341
 47842 S. GIOVANNI IN M. (RN)
 e-mail: mtma@tmarchetti.com
 http://www.tmmarchetti.com

PRODUZIONE MODULI ROTANTI

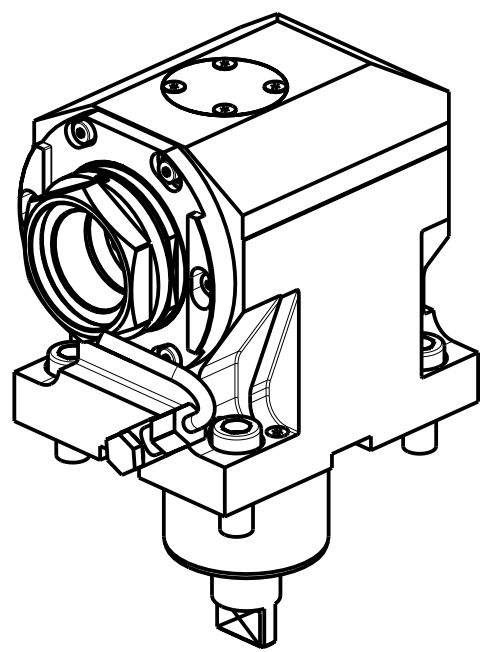
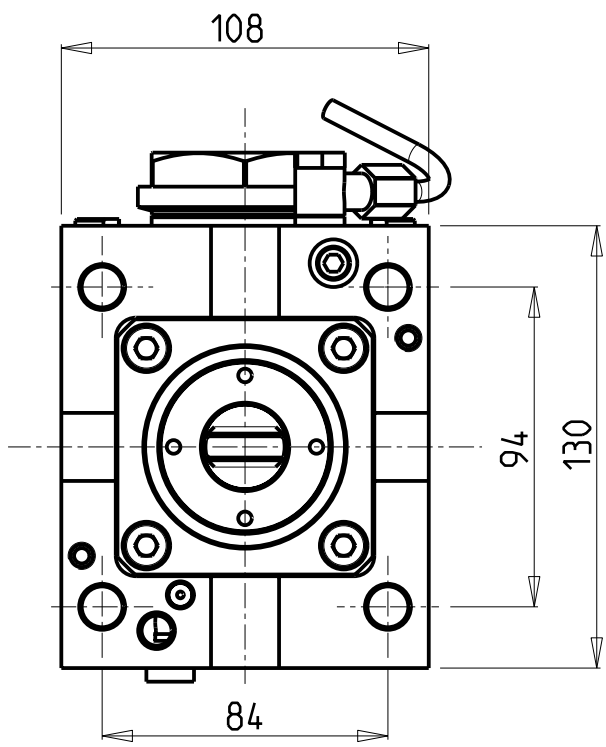
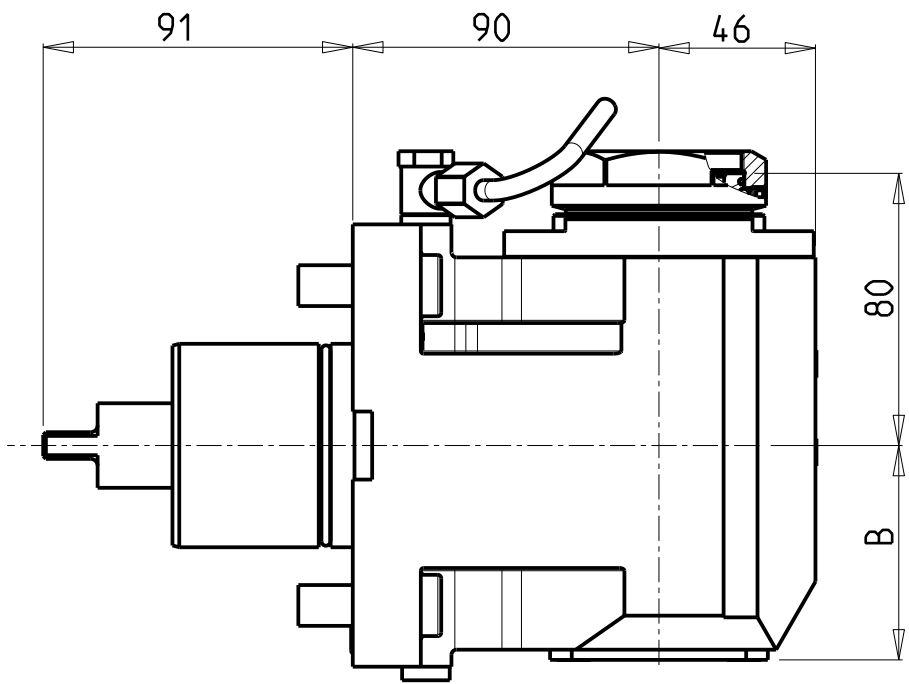
 PAGINA TKW 150-7-10



PER PORTAUTENSILI MODULARI MTSK-40 VEDI PAG. TBL300-1-40 E PER MTSK-50 VEDI PAG. TBL300-1-50
 FOR MTSK-40 QUICK CHANGE TOOLHOLDERS CLAMPINGS SEE PAGE TBL300-1-40 AND FOR MTSK-50 SEE PAGE TBL300-1-50
 FUER MTSK-40 MODULARE WERKZEUGAUFNAHMEN SIEHE SEITE TBL300-1-40 UND FUER MTSK-50 SIEHE SEITE TBL300-1-50

Cod. MT	Mandrino Spindle Spindel	I	RPM	Coppia Max Max Torque Max Drehmoment	Reversibile lato mandrino/contromandrino Reversible sub/main spindle side Umkehrbare Spindel-seite/Gegenspindel-seite	Lubr.interna Coolant through Innenkuehlung	Lubr.esterna Ext. coolant Aussenkuehlung	B	CHIAVI NON INCLUSE Keys not included Schlüssel nicht einbegriffen	
MNL0580140	MTSK-40	1:1	6000	100Nm	X	-	X	63	CHUB46	OKU0430007 •
MNL0580240	MTSK-40	1:1	6000	100Nm	X	P=70bar	X	75.5	CHUB46	OKU0430007 •
MNL0580150	MTSK-50	1:1	6000	100Nm	X	-	X	63	CHUB55	OKU0430007 •
MNL0580250	MTSK-50	1:1	6000	100Nm	X	P=70bar	X	75.5	CHUB55	OKU0430007 •

- Chiave inclusa
- Key included
- Schlüssel inbegriffen

TAKISAWA
 MOD: TS3000/4000/5000 Y/YS 12 ST. (3 KEYS TURRET)

MODULO MOTORIZZATO ASSIALE MTSK
 Axial MTSK driven tool
 Axial MTSK angetriebenes Werkzeug

Subject to change without notice.

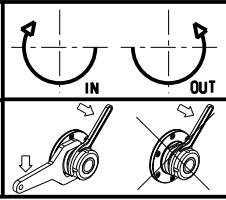

M.T. srl
 Via Casino Albini 480
 Tel. 0541/956034-957884
 Fax 0541/956341
 47842 S. GIOVANNI IN M. (RN)
 e-mail: mtma@tmarchetti.com
 http://www.tmmarchetti.com

PRODUZIONE MODULI ROTANTI

PAGINA TKW 150-7-10-K

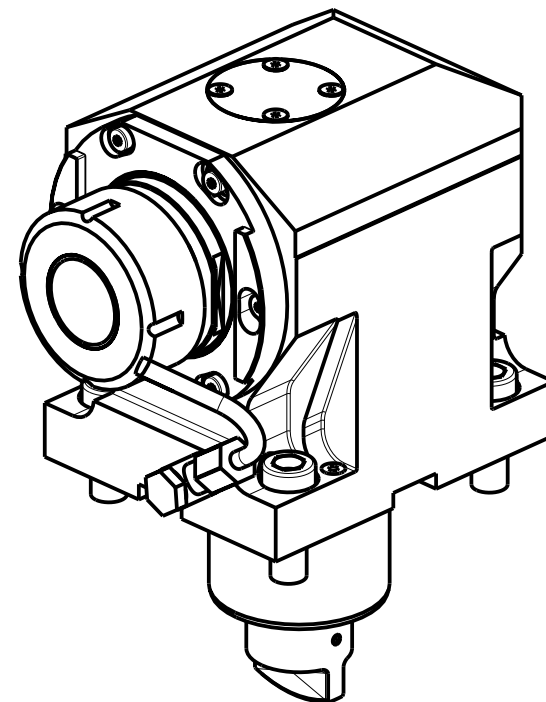
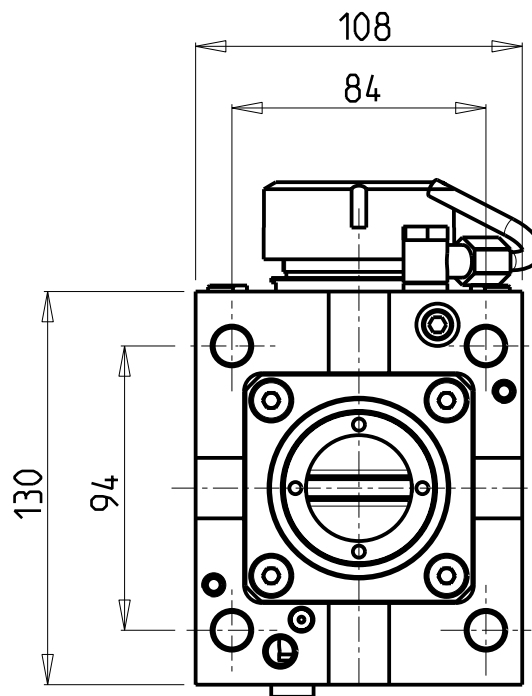
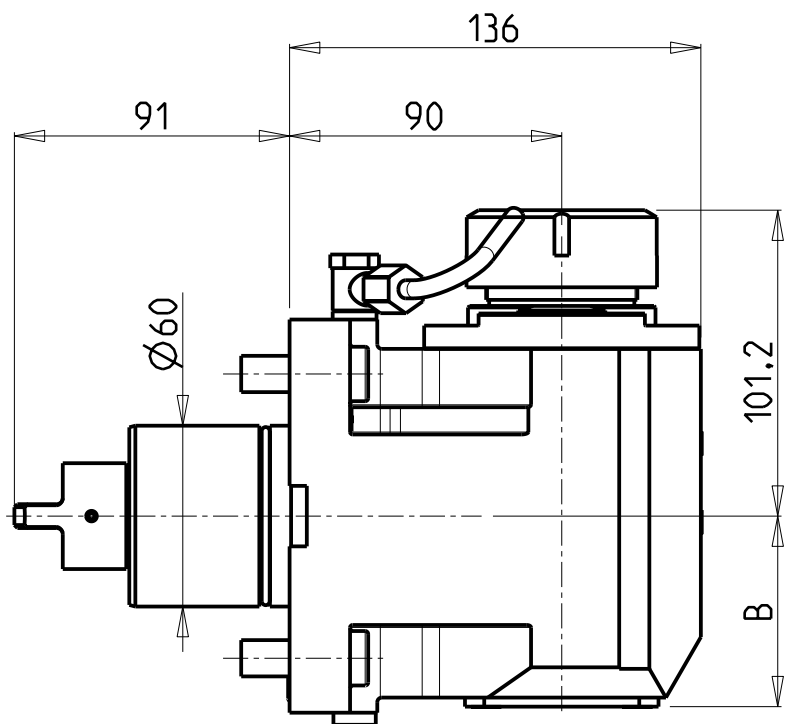

- Chiave inclusa
- Key included
- Schlüssel inbegriffen

Cod. MT	Mandrino Spindle Spindel	I	RPM	Coppia Max Max Torque Max Drehmoment	Reversibile lato mandrino/contromandrino Reversible sub/main spindle side Umkehrbare Spindel-seite/ Gegenspindel-seite	Lubr.interna Coolant through Innenkuehlung	Lubr.esterna Ext. coolant Aussenkuehlung	B	CHIAVI NON INCLUSE Keys not included Schlüssel nicht einbegriffen	
MNL0840140	ER40	1:1	4000	100Nm	X	-	X	63	CHSTER40	OKU0430007 •
MNL0840240	ER40	1:1	4000	100Nm	X	P=70bar	X	75.5	CHSTER40	OKU0430007 •

TAKISAWA

MOD: TS3000/4000/5000 Y/YS 12 ST. (3 KEYS TURRET)

MODULO MOTORIZZATO ASSIALE

Axial driven tool

Axial angetriebenes Werkzeug

Subject to change without notice.

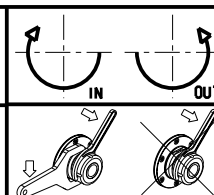

M.T. srl

Via Casino Albini 480
Tel. 0541/956034-957884
Fax 0541/956341

47842 S. GIOVANNI IN M. (RN)
e-mail: mtma@tmarchetti.com
http://www.tmmarchetti.com

PRODUZIONE MODULI ROTANTI



PAGINA TKW 170-7-10

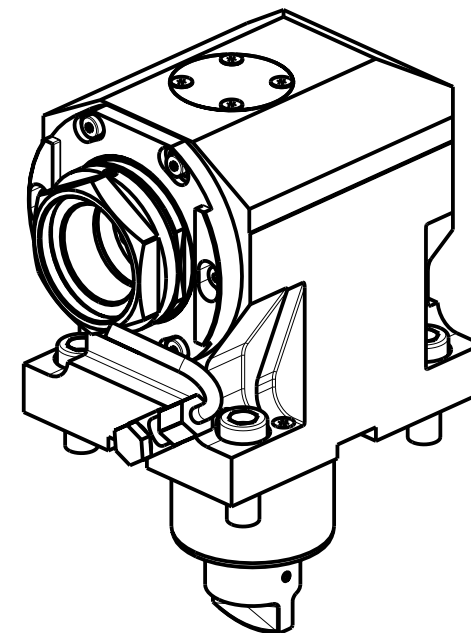
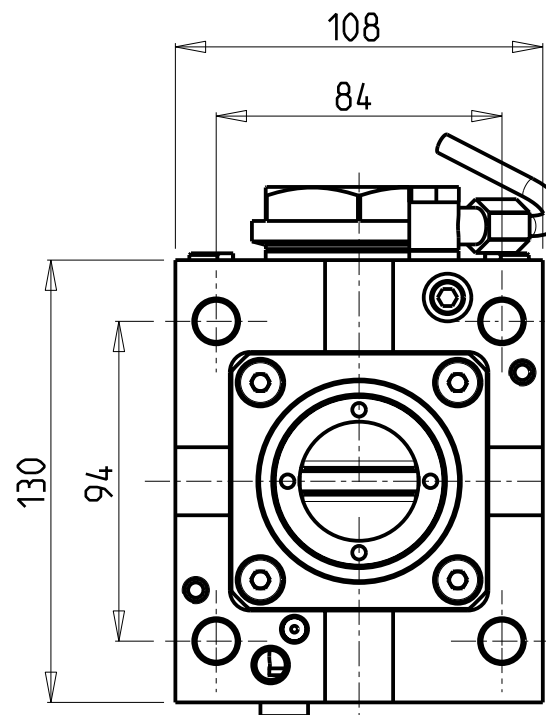
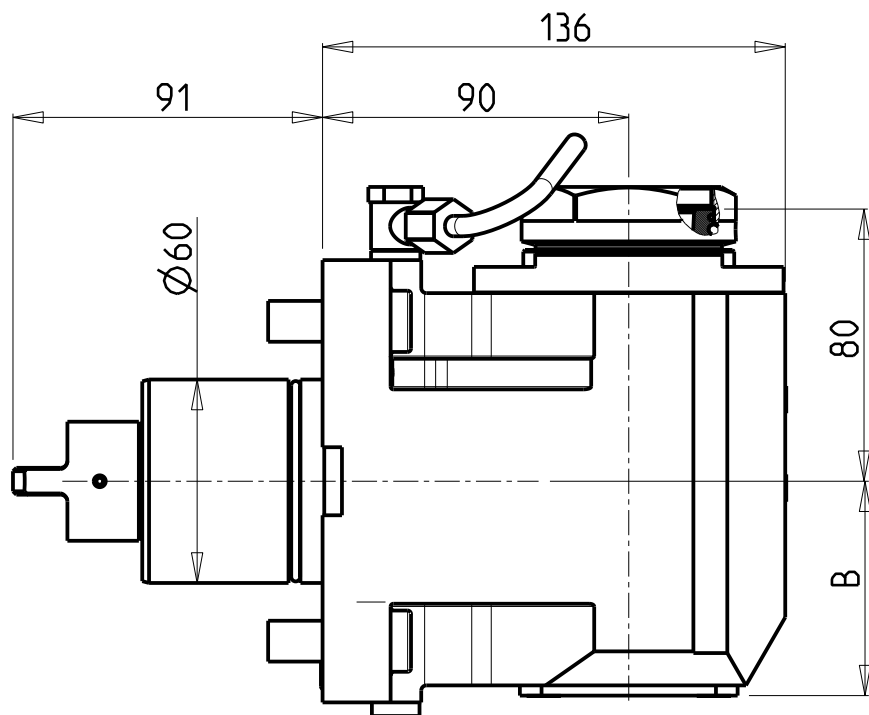

PER PORTAUTENSILI MODULARI MTSK-40 VEDI PAG. TBL300-1-40 E PER MTSK-50 VEDI PAG. TBL300-1-50
 FOR MTSK-40 QUICK CHANGE TOOLHOLDERS CLAMPINGS SEE PAGE TBL300-1-40 AND FOR MTSK-50 SEE PAGE TBL300-1-50
 FUER MTSK-40 MODULARE WERKZEUGAUFNAHMEN SIEHE SEITE TBL300-1-40 UND FUER MTSK-50 SIEHE SEITE TBL300-1-50

Cod. MT	Mandrino Spindel Spindel	I	RPM	Coppia Max Max Torque Max Drehmoment	Reversibile lato mandrino/contromandrino Reversible sub/main spindle side Umkehrbare Spindel-seite/ Gegenspindel-seite	Lubr.interna Coolant through Innenkuehlung	Lubr.esterna Ext. coolant Aussenkuehlung	B	CHIAVI NON INCLUSE Keys not included Schluessel nicht einbegriffen	
MNL0850140	MTSK-40	1:1	4000	100Nm	X	-	X	63	CHUB46	OKU0430007 *
MNL0850240	MTSK-40	1:1	4000	100Nm	X	P=70bar	X	75.5	CHUB46	OKU0430007 *
MNL0850150	MTSK-50	1:1	4000	100Nm	X	-	X	63	CHUB55	OKU0430007 *
MNL0850250	MTSK-50	1:1	4000	100Nm	X	P=70bar	X	75.5	CHUB55	OKU0430007 *

- Chiave inclusa
- Key included
- Schluessel inbegriffen

TAKISAWA
 MOD: TS3000/4000/5000 Y/YS 12 ST. (3 KEYS TURRET)

MODULO MOTORIZZATO ASSIALE MTSK
 Axial MTSK driven tool
 Axial MTSK angetriebenes Werkzeug

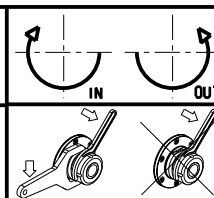

M.T. srl
 Via Casino Albini 480
 Tel. 0541/956034-957884
 Fax 0541/956341
 47842 S. GIOVANNI IN M. (RN)
 e-mail: mtma@tmarchetti.com
 http://www.tmarchetti.com

PRODUZIONE MODULI ROTANTI

PAGINA TKW 170-7-10-K

Subject to change without notice.

10/2018

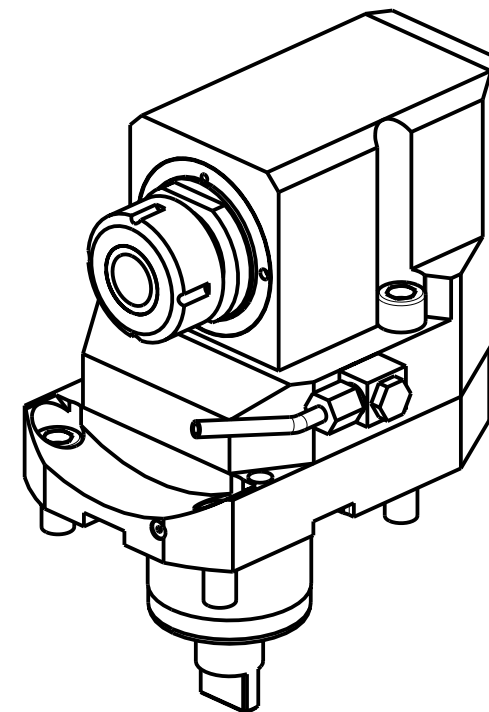
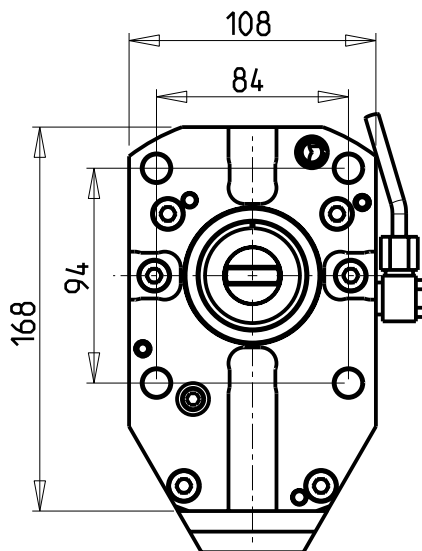
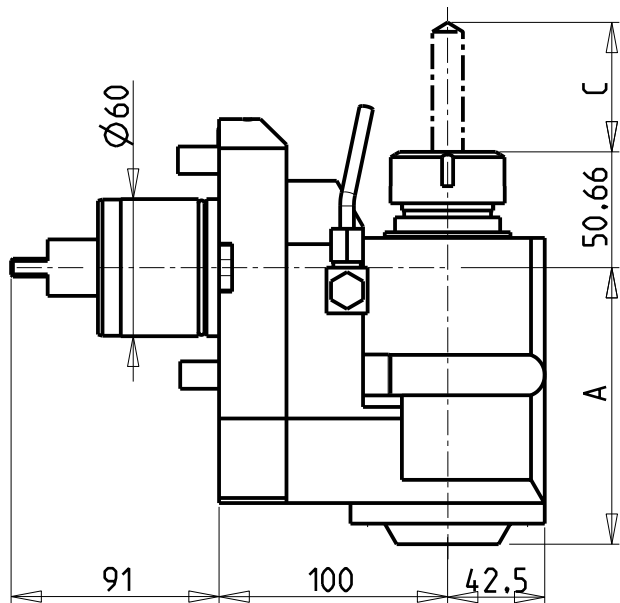
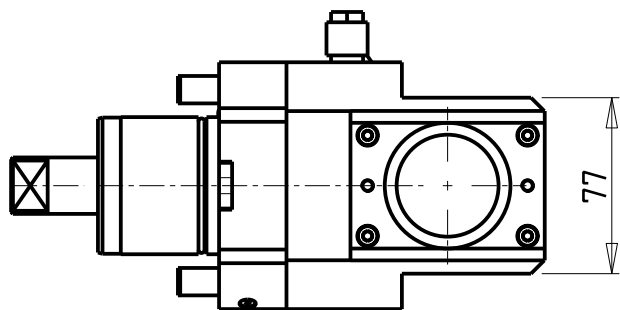

Cod. MT	Mandrino Spindle Spindel	I	RPM	Coppia Max Max Torque Max Drehmoment	Reversibile lato mandrino/contromandrino Reversible sub/main spindle side Umkehrbare Spindel-seite/ Gegenspindel-seite	Lubrificazione int. Coolant through Innenkuehlung	Lubrificazione est. Ext. coolant Aussenkuehlung	A	C max	CHIAVI NON INCLUSE Keys not included Schlüssel nicht einbegriffen
MNL0290632	ER32	1:1	6000	100Nm	X		X	121	118	CHUB46 CHSTER32
MNL0291632	ER32	1:1	6000	100Nm	X	P=70bar	X	135	118	CHUB46 CHSTER32

TAKISAWA
 MOD: TS3000/4000/5000 Y/YS 12 ST. (3 KEYS TURRET)

MODULO MOTORIZZATO ASSIALE ARRETRATO
 Axial rear-set driven tool
 Axial angetriebenes Werkzeug zurueckversetzt

Subject to change without notice.

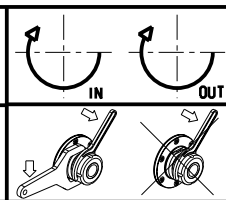

M.T. srl
 Via Casino Albini 480
 Tel. 0541/956034-957884
 Fax 0541/956341
 47842 S. GIOVANNI IN M. (RN)
 e-mail: mtma@mtmarchetti.com
 http://www.mtmarchetti.com

PRODUZIONE MODULI ROTANTI

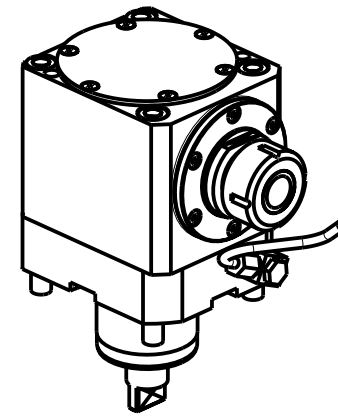
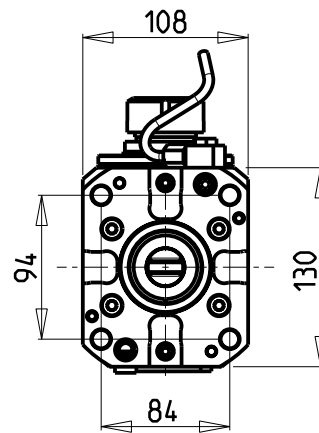
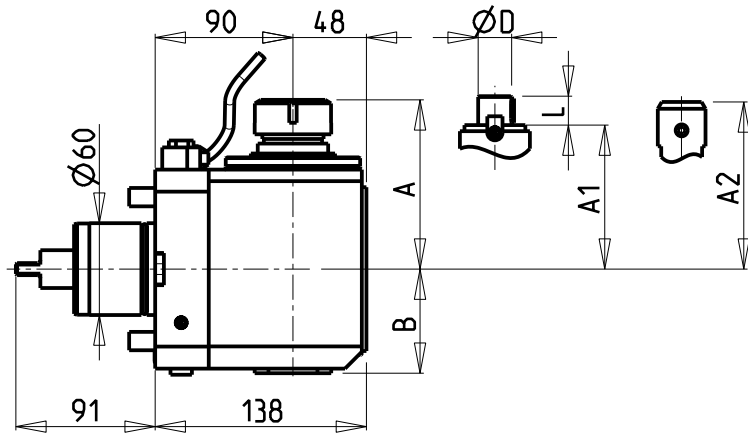
 PAGINA TKW 180-7-10



- Chiave inclusa
- Key included
- Schluessel inbegriffen

Cod. MT	Mandrino Spindel Spindel	I	RPM	Coppia Max Max Torque Max Drehmoment	Reversibile lato mandrino/contromandrino Reversible sub/main spindle side Umkehrbare Spindel-seite/ Gegenspindel-seite	Lubrificazione int. Coolant through Innenkühlung	Lubrificazione est. Ext. coolant Aussenkühlung	A	A1	A2	B	D	L	CHIAVI NON INCLUDE Keys not included Schluessel nicht einbegriffen	
MNL0330525	ER25	2:1	3000	100Nm	X	-	X	107.5	-	-	68	-	-	OKU0650004	CHSTER25
MNL0331525	ER25	2:1	3000	100Nm	X	P=70bar	X	107.5	-	-	79	-	-	OKU0650004	CHSTER25
MNL0330532	ER32	2:1	3000	100Nm	X	-	X	110.56	-	-	68	-	-	OKU0650004	CHSTER32
MNL0331532	ER32	2:1	3000	100Nm	X	P=70bar	X	110.56	-	-	79	-	-	OKU0650004	CHSTER32
MNL0330140	ER40	2:1	3000	100Nm	X	-	X	113.16	-	-	68	-	-	OKU0650004	CHSTER40
MNL0331140	ER40	2:1	3000	100Nm	X	P=70bar	X	113.16	-	-	79	-	-	OKU0650004	CHSTER40
MNL0331617	Ø16X17	2:1	3000	100Nm	X	-	X	-	87.5	-	68	16	17	CHUB46	CH_VTCROCE_M08
MNL0332219	Ø22X19	2:1	3000	100Nm	X	-	X	-	87.5	-	68	22	19	CHUB46	CH_VTCROCE_M10
MNL0332721	Ø27x21	2:1	3000	100Nm	X	-	X	-	87.5	-	68	27	21	CHUB46	CH_VTCROCE_M12
MNL0332519	Ø1''X19	2:1	3000	100Nm	X	-	X	-	87.5	-	68	1"	19	CHUB46	CH_VTCROCE_M12
MNL0330120	WELDON 20	2:1	3000	100Nm	X	-	X	-	-	105.5	68	-	-	-	-
MNL0330220	WELDON 20	2:1	3000	100Nm	X	P=70bar	X	-	-	105.5	91.5	-	-	-	-
MNL0330125	WELDON 25	2:1	3000	100Nm	X	-	X	-	-	115	68	-	-	-	-
MNL0330225	WELDON 25	2:1	3000	100Nm	X	P=70bar	X	-	-	115	91.5	-	-	-	-
MNL0330132	WELDON 32	2:1	3000	100Nm	X	-	X	-	-	131.5	68	-	-	-	-
MNL0330232	WELDON 32	2:1	3000	100Nm	X	P=70bar	X	-	-	131.5	91.5	-	-	-	-

TAKISAWA
 MOD: TS3000/4000/5000 Y/YS 12 ST. (3 KEYS TURRET)

MODULO MOTORIZZATO ASSIALE RIDOTTO I=2:1
 Axial geared-down I=2:1 driven tool
 Axial angetriebenes Werkzeug untersetzt I=2:1

Subject to change without notice.

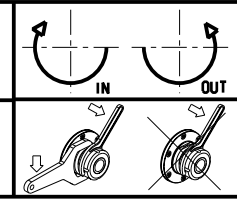

M.T. srl
 Via Casino Albini 480
 Tel. 0541/956034-957884
 Fax 0541/956341
 47842 S. GIOVANNI IN M. (RN)
 e-mail: mtma@tmarchetti.com
 http://www.tmmarchetti.com

PRODUZIONE MODULI ROTANTI



PAGINA TKW 190-7-10

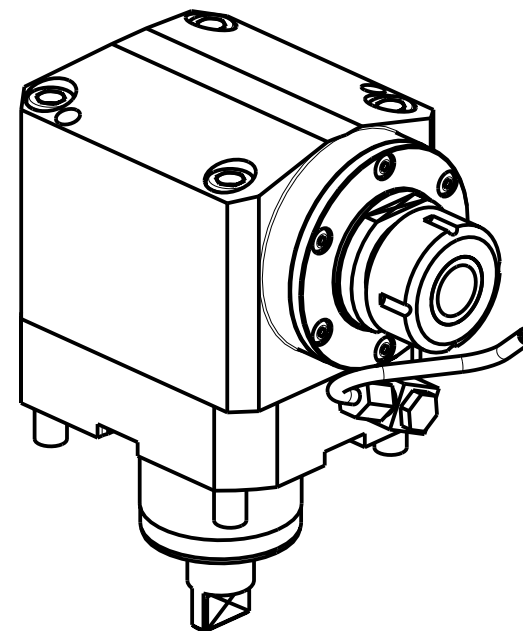
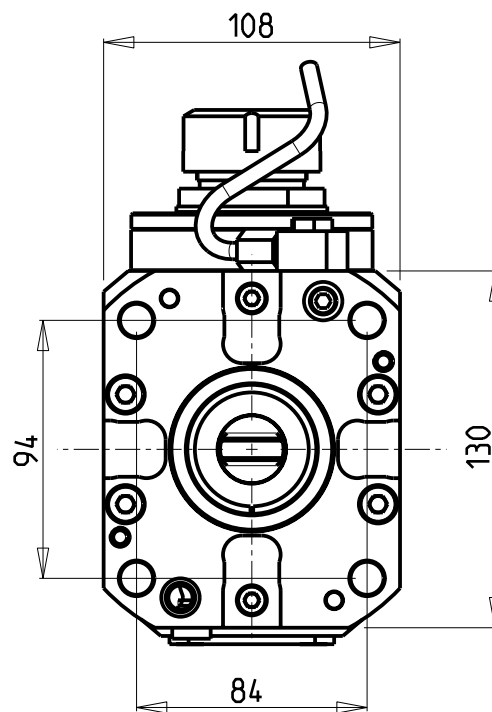
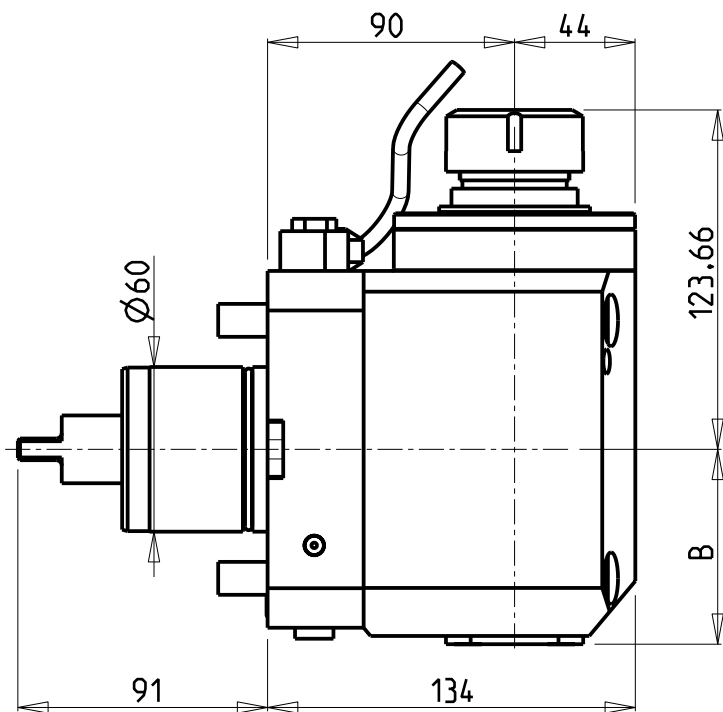

Cod. MT	Mandrino Spindle Spindel	I	RPM	Coppia Max Max Torque Max Drehmoment	Reversibile lato mandrino/contromandrino Reversible sub/main spindle side Umkehrbare Spindel-seite/ Gegenspindel-seite	Lubrificazione int. Coolant through Innenkühlung	Lubrificazione est. Ext. coolant Aussenkühlung	B	CHIAVI NON INCLUSE Keys not included Schlüssel nicht einbegriffen	
MNL0350532	ER32	1:2	12000	50Nm	X		X	71	CHUB46	CHSTER32
MNL0351532	ER32	1:2	12000	50Nm	X	P=70bar	X	94.5	CHUB46	CHSTER32

TAKISAWA
 MOD: TS3000/4000/5000 Y/YS 12 ST. (3 KEYS TURRET)

MODULO MOTORIZZATO ASSIALE MOLTIPLICATO I=1:2
 Axial geared-up I=1:2 driven tool
 Axial angetriebenes Werkzeug uebersetzt I=1:2

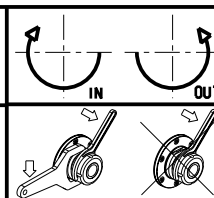

M.T. srl
 Via Casino Albini 480
 Tel. 0541/956034-957884
 Fax 0541/956341
 47842 S. GIOVANNI IN M. (RN)
 e-mail: mtma@mtmarchetti.com
 http://www.mtmarchetti.com

PRODUZIONE MODULI ROTANTI



PAGINA TKW 200-7-10

Subject to change without notice.

10/2018

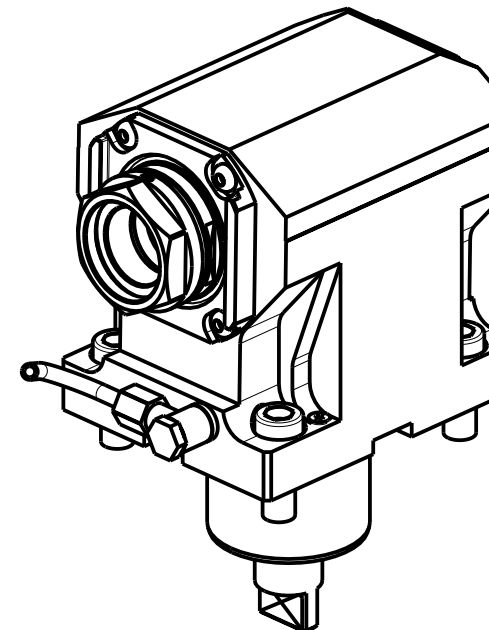
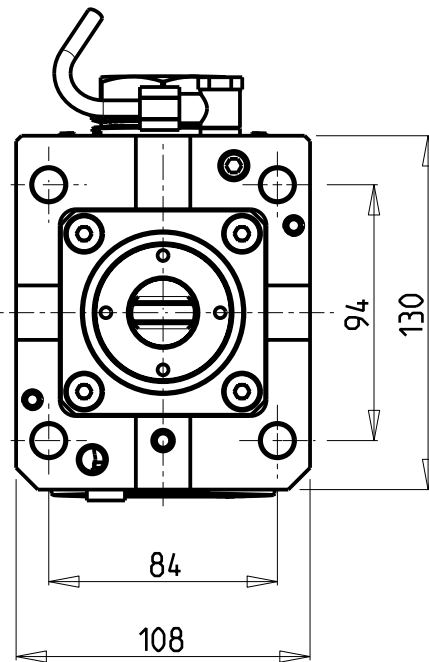
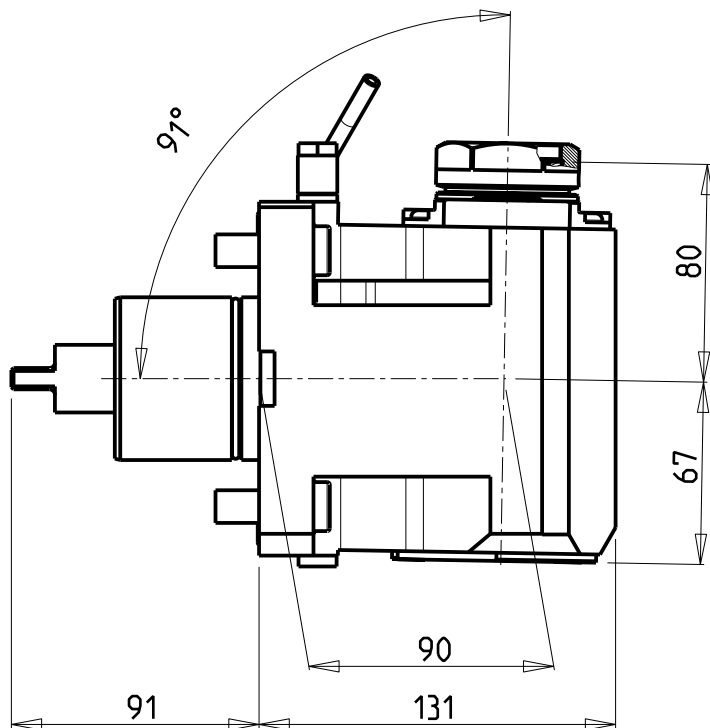

PER PORTAUTENSILI MODULARI MTSK-40 VEDI PAG. TBL300-1-40
 FOR MTSK-40 QUIK CHANGE TOOLHOLDERS CLAMPINGS SEE PAGE TBL300-1-40
 FUER MTSK-40 MODULARE WERKZEUGAUFNAHMEN SIEHE SEITE TBL300-1-40

Cod. MT	Mandrino Spindle Spindel	I	RPM	Coppia Max Max Torque Max Drehmoment	Reversibile lato mandrino/contromandrino Reversible sub/main spindle side Umkehrbare Spindel-seite/ Gegenspindel-seite	Lubr.esterna Ext. coolant Aussenkuehlung	CHIAVI NON INCLUSE Keys not included Schlüssel nicht einbegriffen
MNL0900140	MTSK-40	1:1	6000	50Nm	X	X	CHUB46 OKU0650004 *

- Chiave inclusa
- Key included
- Schlüssel inbegriffen

TAKISAWA

MOD: TS3000/4000/5000 Y/YS 12 ST. (3 KEYS TURRET)

MODULO MOTORIZZATO ASSIALE MTSK PER POLIGONATURA INTERNA H=90mm

Axial MTSK driven tool for internal polygon-making H=90mm

Axial MTSK angetriebenes Werkzeug fuer interne Facettierung H=90mm

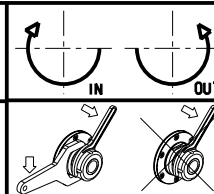

M.T. srl

Via Casino Albini 480
 Tel. 0541/956034-957884
 Fax 0541/956341
 47842 S. GIOVANNI IN M. (RN)
 e-mail: mtma@mtmarchetti.com
 http://www.mtmarchetti.com

PRODUZIONE MODULI ROTANTI



PAGINA TKW 231-7-10-K

Subject to change without notice.

10/2018

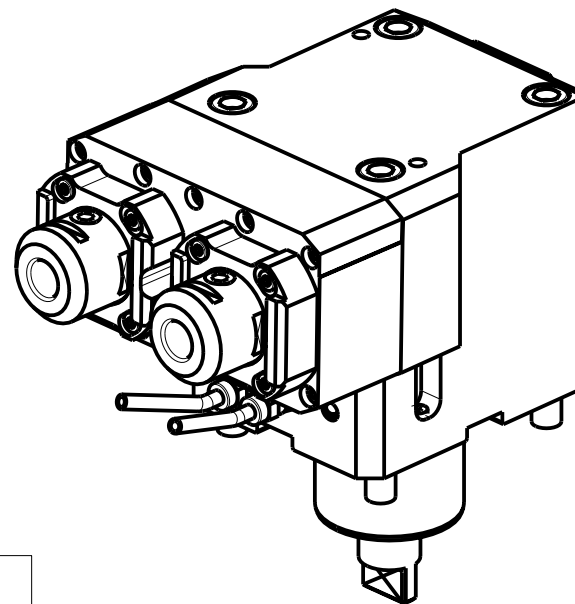
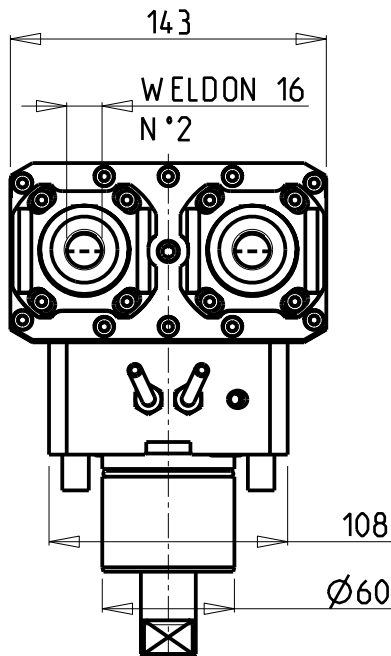
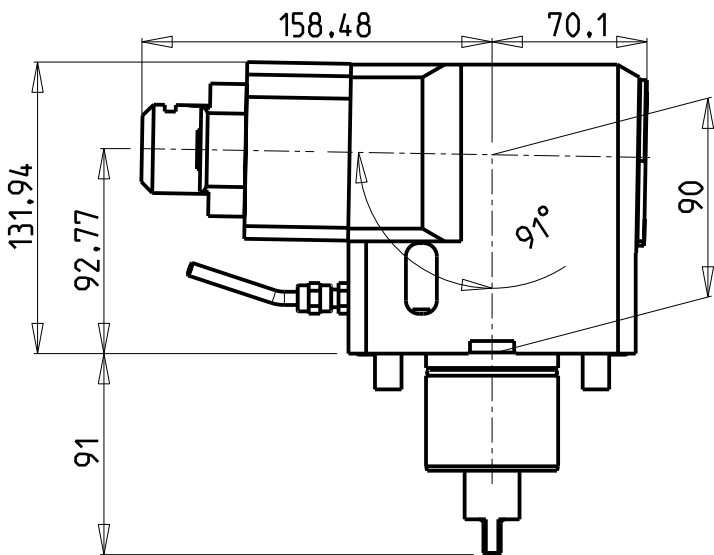
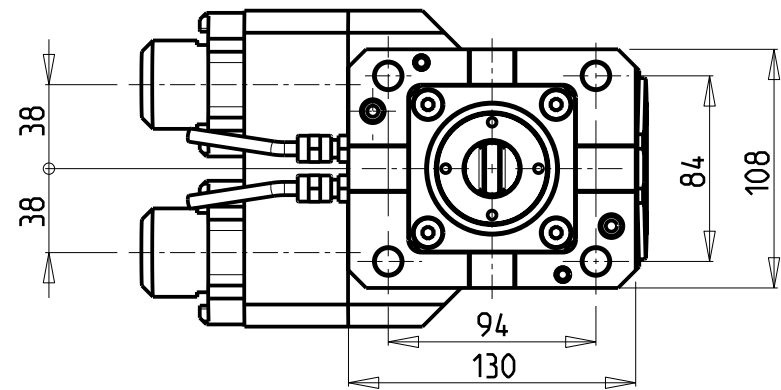

ATTENZIONE - ATTENTION - ACHTUNG

- Per lo smontaggio degli utensili utilizzare sempre la chiave di contrasto come indicato nel manuale d'uso.
- For disassembly of the tools use always the contrast key as mentioned in the user instructions.
- Fuer das Abmontieren der Werkzeuge immer den Gegenschuessel benutzen wie in der Bedienungsanleitung erwaehnt.

Cod. MT	Mandrino Spindle Spindel	I	RPM	Coppia Max Max Torque Max Drehmoment	Reversibile lato mandrino/contromandrino Reversible sub/main spindle side Umkehrbare Spindel-seite/ Gegenspindel-seite	Lubr.esterna Ext. coolant Aussenkuehlung	CHIAVI INCLUDE Keys included Schluessel inbegriffen
MNL0940616	WELDON 16	1:1	6000	50Nm	X	X	SAU0070027

TAKISAWA

MOD: TS3000/4000/5000 Y/YS 12 ST. (3 KEYS TURRET)

MODULO MOTORIZZATO ASSIALE 2 USCITE IN Y PER POLIGONATURA INTERNA H=90mm
 Axial Single side twin head driven tool in Y for internal polygon-making H=90mm
 Axial angetriebenes Werkzeug 2 Ausgaenge in Y fuer interne Facettierung H=90mm

Subject to change without notice.

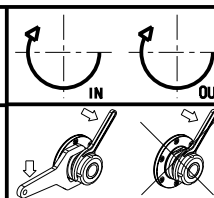

M.T. srl

Via Casino Albini 480
 Tel. 0541/956034-957884
 Fax 0541/956341
 47842 S. GIOVANNI IN M. (RN)
 e-mail: mtma@mtmarchetti.com
 http://www.mtmarchetti.com

PRODUZIONE MODULI ROTANTI



PAGINA TKW 233-7-10

ATTENZIONE - ATTENTION - ACHTUNG

- Per lo smontaggio degli utensili utilizzare sempre la chiave di contrasto come indicato nel manuale d'uso.
- For disassembly of the tools use always the contrast key as mentioned in the user instructions.
- Fuer das Abmontieren der Werkzeuge immer den Gegenschlüssel benutzen wie in der Bedienungsanleitung erwäehnt.

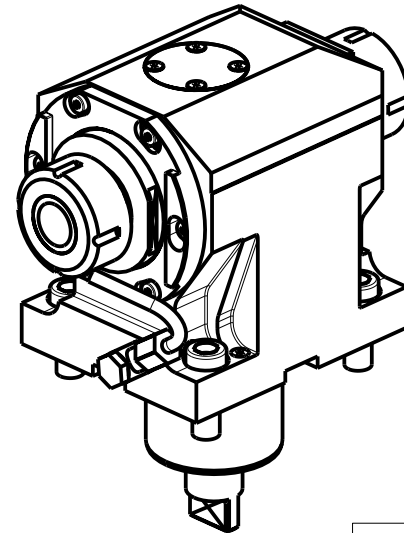
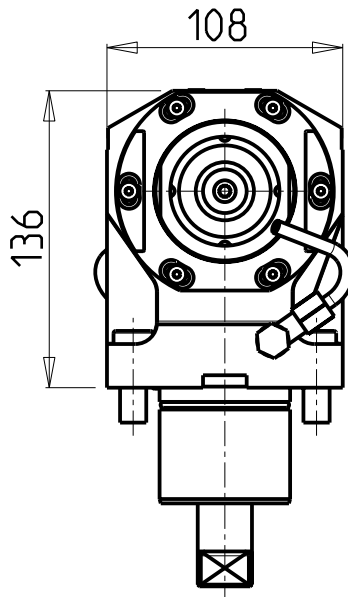
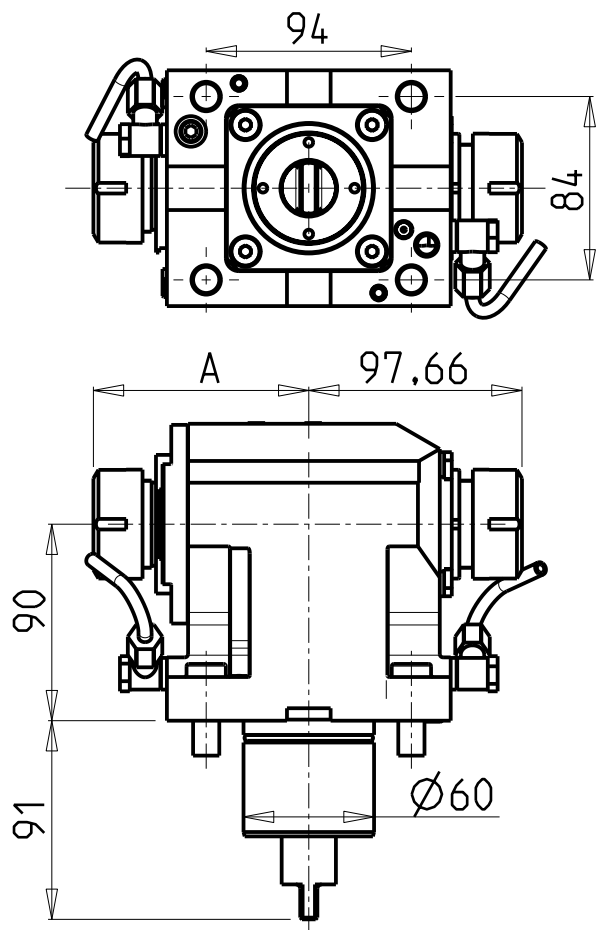

- Chiave inclusa
- Key included
- Schlüssel inbegriffen

Cod. MT	Mandrino Spindle Spindel	I	RPM	Coppia Max Max Torque Max Drehmoment	Reversibile lato mandrino/contromandrino Reversible sub/main spindle side Umkehrbare Spindel-seite/ Gegenspindel-seite	Lubr.esterna Ext. coolant Aussenkuehlung	A	CHIAVI NON INCLUSE Keys not included Schluessel nicht einbegriffen
MNL0830232	ER32+ER32	1:1	6000	100Nm	X	X	98.7	OKU0430007 ▪ CHSTER32 -
MNL0830240	ER40+ER32	1:1	6000	100Nm	X	X	101.7	OKU0430007 ▪ CHSTER32 CHSTER40

TAKISAWA

MOD: TS3000/4000/5000 Y/YS 12 ST. (3 KEYS TURRET)

MODULO MOTORIZZATO ASSIALE BISPORGENTE

Axial opposite face twin driven tool

Axial angetriebenes Werkzeug halb vorspringend

Subject to change without notice.

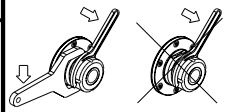

M.T. srl

Via Casino Albini 480
Tel. 0541/956034-957884
Fax 0541/956341

47842 S. GIOVANNI IN M. (RN)
e-mail: mtma@mtmarchetti.com
http://www.mtmarchetti.com

PRODUZIONE MODULI ROTANTI



PAGINA TKW 240-7-10

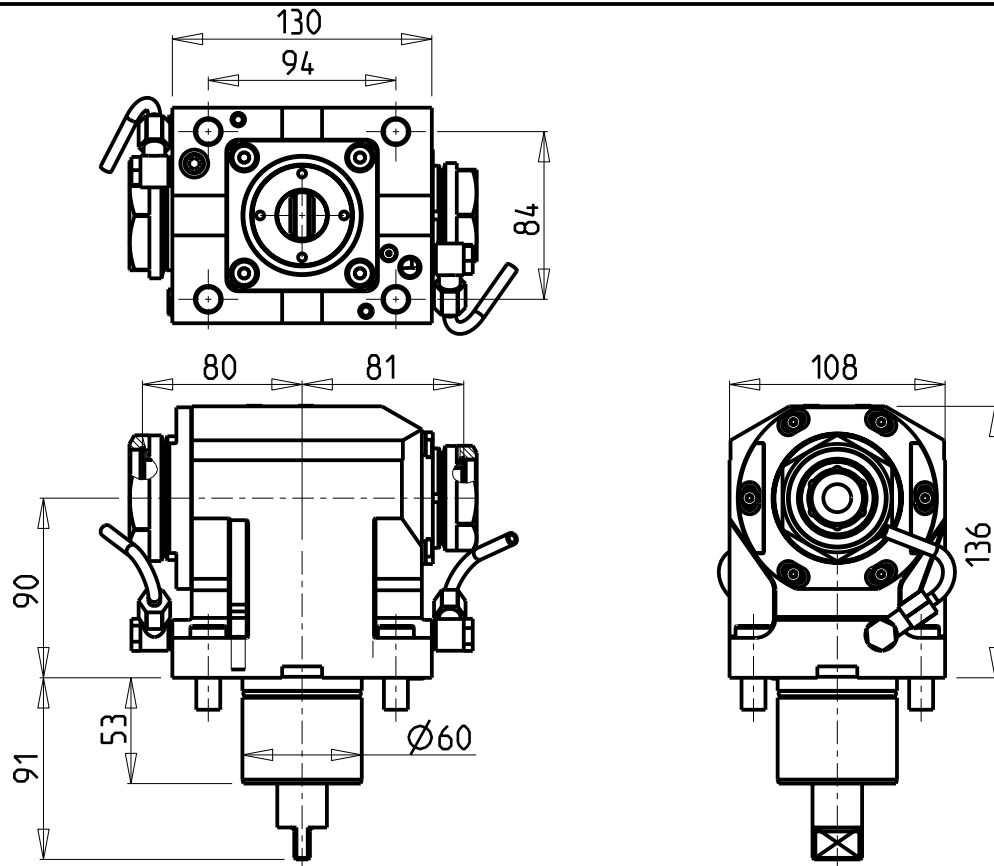

ATTENZIONE - ATTENTION - ACHTUNG

- Per lo smontaggio degli utensili utilizzare sempre la chiave di contrasto come indicato nel manuale d'uso.
- For disassembly of the tools use always the contrast key as mentioned in the user instructions.
- Fuer das Abmontieren der Werkzeuge immer den Gegenschlüssel benutzen wie in der Bedienungsanleitung erwaehnt.

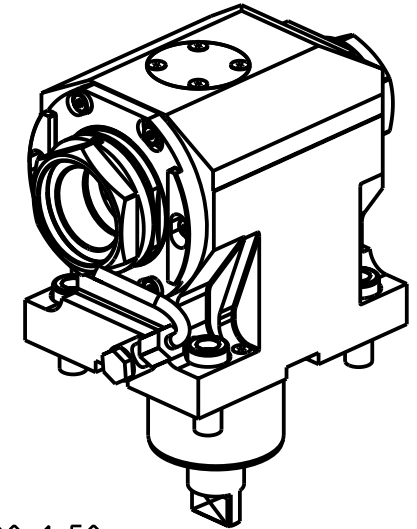

PER PORTAUTENSILI MODULARI MTSK-40 VEDI PAG. TBL300-1-40 E PER MTSK-50 VEDI PAG. TBL300-1-50
 FOR MTSK-40 QUIK CHANGE TOOLHOLDERS CLAMPINGS SEE PAGE TBL300-1-40 AND FOR MTSK-50 SEE PAGE TBL300-1-50
 FUER MTSK-40 MODULARE WERKZEUGAUFNAHMEN SIEHE SEITE TBL300-1-40 UND FUER MTSK-50 SIEHE SEITE TBL300-1-50

Cod. MT	Mandrino Spindle Spindel	I	RPM	Coppia Max Max Torque Max Drehmoment	Reversibile lato mandrino/contromandrino Reversible sub/main spindle side Umkehrbare Spindel-seite/ Gegenspindel-seite	Lubr.esterna Ext. coolant Aussenkuehlung	CHIAVI NON INCLUSE Keys not included Schluesssel nicht einbegriffen		
							CHUB46	CHUB55	OKU0430007 *
MNL1015040	MTSK-50+MTSK-40	1:1	6000	100Nm	X	X	CHUB46	CHUB55	OKU0430007 *

- Chiave inclusa
- Key included
- Schluesssel inbegriffen

TAKISAWA
 MOD: TS3000/4000/5000 Y/YS 12 ST. (3 KEYS TURRET)

MODULO MOTORIZZATO ASSIALE BISPORGENTE MTSK
 Axial MTSK opposite face twin driven tool
 Axial MTSK angetriebenes Werkzeug halb vorspringend

Subject to change without notice.

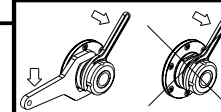

M.T. srl
 Via Casino Albini 480
 Tel. 0541/956034-957884
 Fax 0541/956341
 47842 S. GIOVANNI IN M. (RN)
 e-mail: mtma@mtmarchetti.com
 http://www.mtmarchetti.com

PRODUZIONE MODULI ROTANTI



PAGINA TKW 240-7-10-K

ATTENZIONE - ATTENTION - ACHTUNG

- Per lo smontaggio degli utensili utilizzare sempre la chiave di contrasto come indicato nel manuale d'uso.
- For disassembly of the tools use always the contrast key as mentioned in the user instructions.
- Fuer das Abmontieren der Werkzeuge immer den Gegenschlüssel benutzen wie in der Bedienungsanleitung erwaeht.

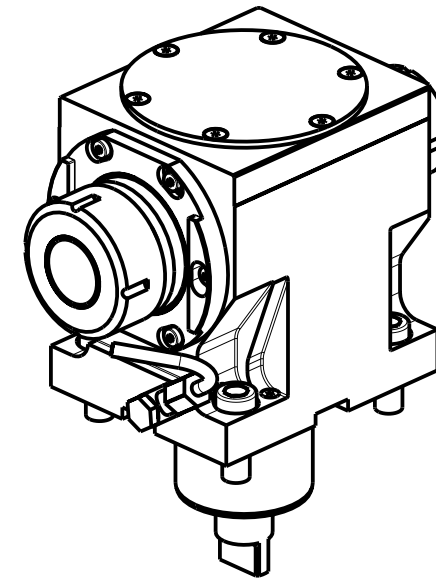
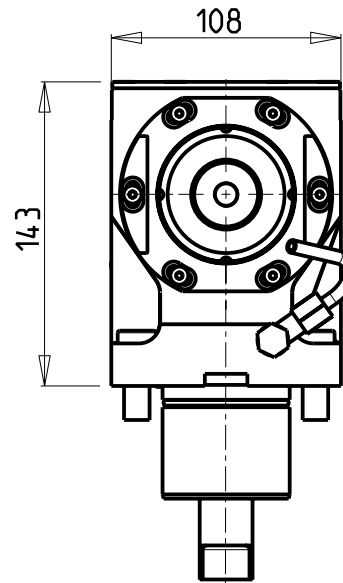
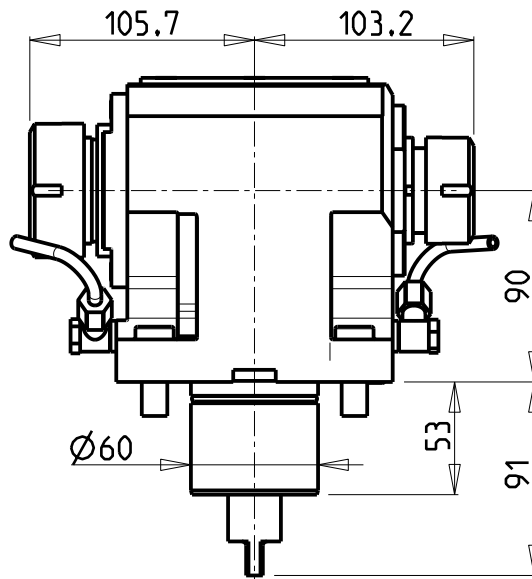
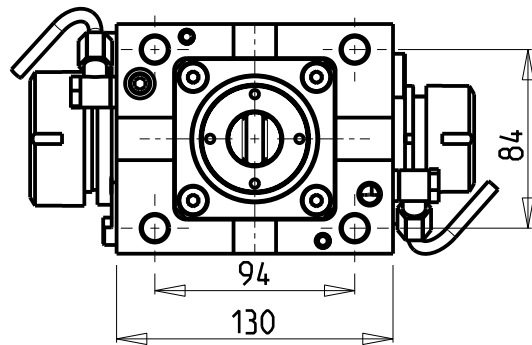

Cod. MT	Mandrino Spindle Spindel	I	RPM	Coppia Max Max Torque Max Drehmoment	Reversibile lato mandrino/contromandrino Reversible sub/main spindle side Umkehrbare Spindel-seite/ Gegenspindel-seite	Lubr.esterna Ext. coolant Aussenkuehlung	CHIAVI NON INCLUSE Keys not included Schluesssel nicht einbegriffen		
MNL0914032	ER40+ER32	2:1	3000	130Nm	X	X	OKU0430007	CHSTER40	CHSTER32

- Chiave inclusa
- Key included
- Schluesssel inbegriffen

TAKISAWA
 MOD: TS3000/4000/5000 Y/YS 12 ST. (3 KEYS TURRET)
 MODULO MOTORIZZATO ASSIALE BISPORGENTE RIDOTTO I=2:1
 Axial geared-down I=2:1 opposite face twin driven tool
 Axial angetriebenes Werkzeug halb vorspringend untersetzt I=2:1

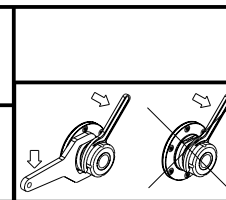

M.T. srl
 Via Casino Albini 480
 Tel. 0541/956034-957884
 Fax 0541/956341
 47842 S. GIOVANNI IN M. (RN)
 e-mail: mtma@tmarchetti.com
 http://www.mtmarchetti.com

PRODUZIONE MODULI ROTANTI

PAGINA TKW 247-7-10

Subject to change without notice.

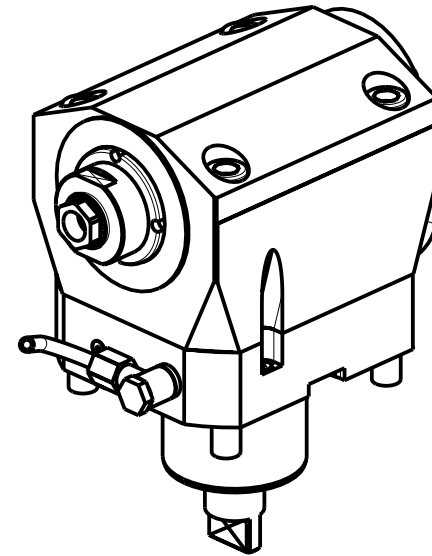
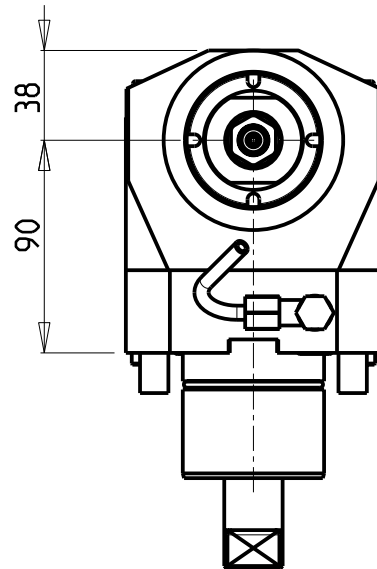
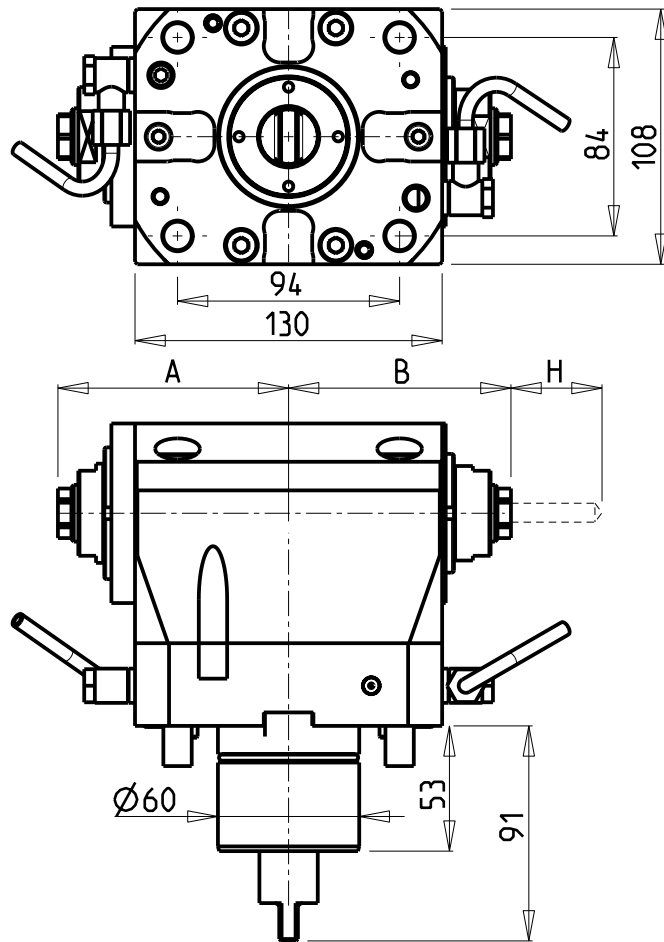

ATTENZIONE - ATTENTION - ACHTUNG

- Per lo smontaggio degli utensili utilizzare sempre la chiave di contrasto come indicato nel manuale d'uso.
- For disassembly of the tools use always the contrast key as mentioned in the user instructions.
- Fuer das Abmontieren der Werkzeuge immer den Gegenschlüssel benutzen wie in der Bedienungsanleitung erwaeht.

Cod. MT	Mandrino Spindle Spindel	I	RPM	Coppia Max Max Torque Max Drehmoment	Reversibile lato mandrino/contromandrino Reversible sub/main spindle side Umkehrbare Spindel-seite/ Gegenspindel-seite	Lubr.esterna Ext. coolant Aussenkuehlung	A	B	H Max Lato contromand. Subspindle side Gegenspindel-seite	CHIAVI NON INCLUSE Keys not included Schlüssel nicht einbegriffen	
MNL0450116	ERA16+ERA16	1:2	12000	50Nm	X	X	97.63	94.13	77.6	CHUB36	CHUB19_SP3
MNL0450120	ERA20+ERA20	1:2	12000	50Nm	X	X	95.73	93.73	78	CHUB36	CHUB22

TAKISAWA

MOD: TS3000/4000/5000 Y/YS 12 ST. (3 KEYS TURRET)

MODULO MOTORIZZATO ASSIALE BISPORGENTE MOLTIPLICATO I=1:2

Axial geared-up I=1:2 opposite face twin driven tool

Axial angetriebenes Werkzeug halb vorspringend uebersetzt I=1:2

Subject to change without notice.

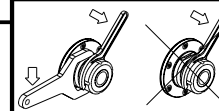

M.T. srl

Via Casino Albini 480
Tel. 0541/956034-957884
Fax 0541/956341
47842 S. GIOVANNI IN M. (RN)
e-mail: mtma@mtmarchetti.com
http://www.mtmarchetti.com

PRODUZIONE MODULI ROTANTI



PAGINA TKW 250-7-10

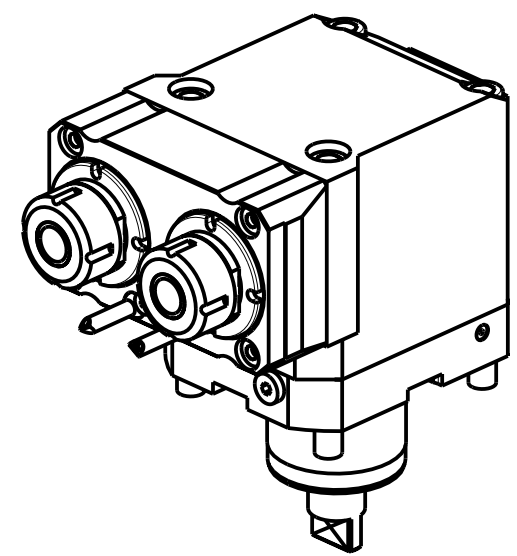
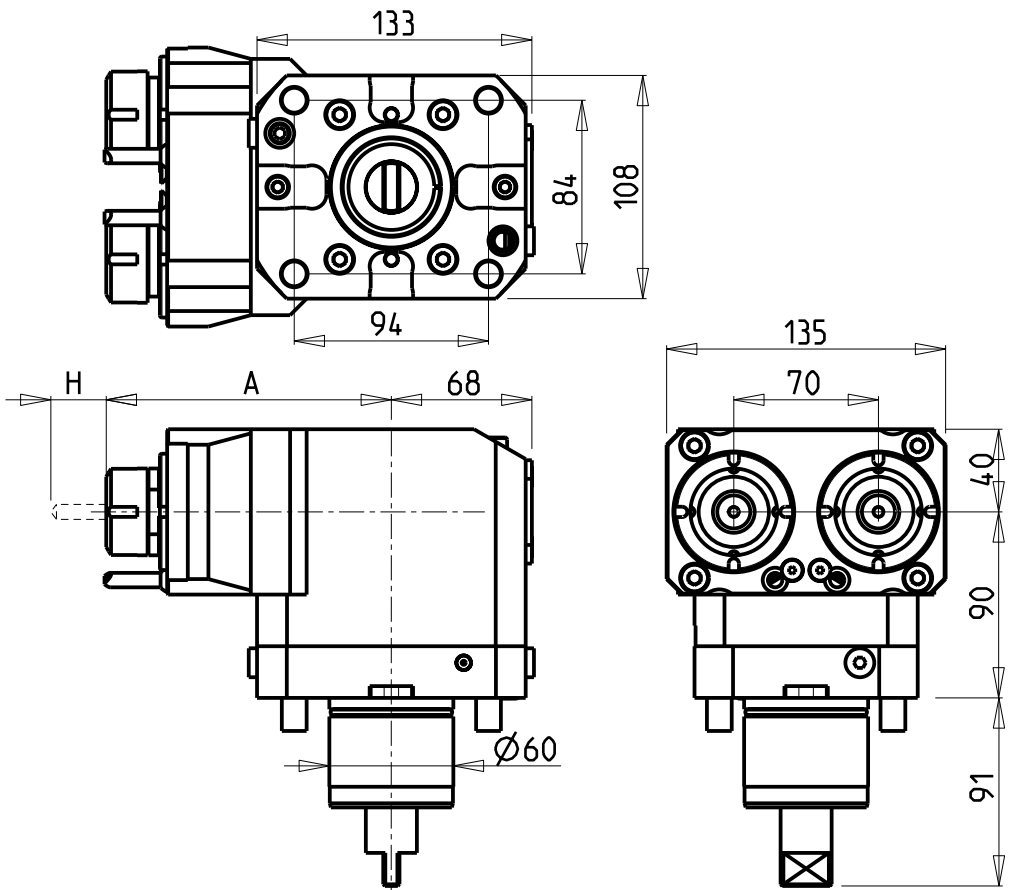

ATTENZIONE - ATTENTION - ACHTUNG

- Per lo smontaggio degli utensili utilizzare sempre la chiave di contrasto come indicato nel manuale d'uso.
- For disassembly of the tools use always the contrast key as mentioned in the user instructions.
- Fuer das Abmontieren der Werkzeuge immer den Gegenschlüssel benutzen wie in der Bedienungsanleitung erwaeht.

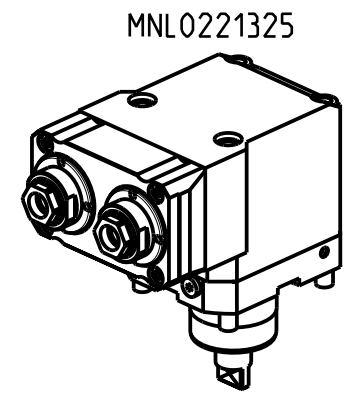

Cod. MT	Mandrino Spindle Spindel	I	RPM	Coppia Max Max Torque Max Drehmoment	Reversibile lato mandrino/contromandrino Reversible sub/main spindle side Umkehrbare Spindel-seite/ Gegenspindel-seite	Lubr.interna Coolant through Innenkuehlung	Lubr.esterna Ext. coolant Aussenkuehlung	A	H max Lato contromandrino Subspindle side Gegenspindel-seite	CHIAVI NON INCLUSE Keys not included Schluessel nicht einbegriffen	
										CHUB36	CHSTER25
MNL0220225	ER25	1:1	6000	40Nm	X		X	137.96	28.5	CHUB36	CHSTER25
MNL0221225	ER25	1:1	6000	40Nm	X	P=70bar	X	162.66	6.95	CHUB36	CHSTER25
MNL0221325	ER A 25	1:1	6000	40Nm	X	P=70bar	X	156.03	14.5	CHUB38	CHUB27

TAKISAWA
 MOD: TS3000/4000/5000 Y/YS 12 ST. (3 KEYS TURRET)

MODULO MOTORIZZATO ASSIALE 2 USCITE IN Y
 Axial Single side twin head driven tool in Y
 Axial angetriebenes Werkzeug 2 Ausgaenge in Y

Subject to change without notice.

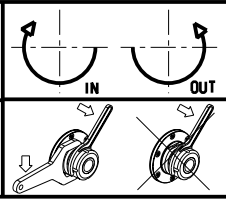

M.T. srl
 Via Casino Albini 480
 Tel. 0541/956034-957884
 Fax 0541/956341
 47842 S. GIOVANNI IN M. (RN)
 e-mail: mtma@mtmarchetti.com
 http://www.mtmarchetti.com

PRODUZIONE MODULI ROTANTI



PAGINA TKW 260-7-10

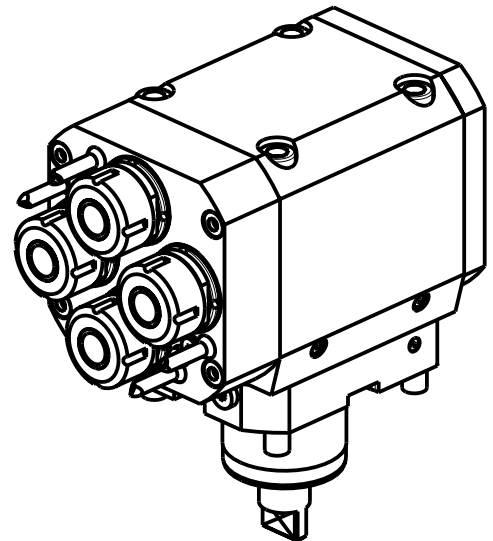
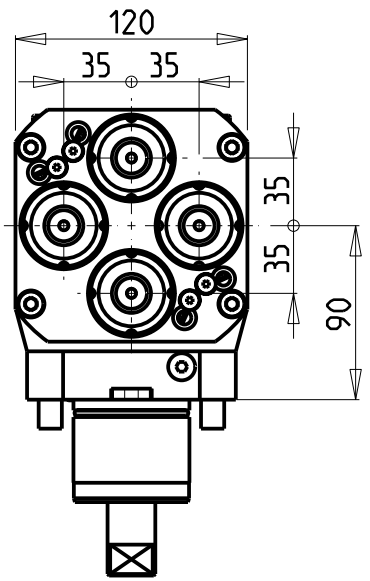
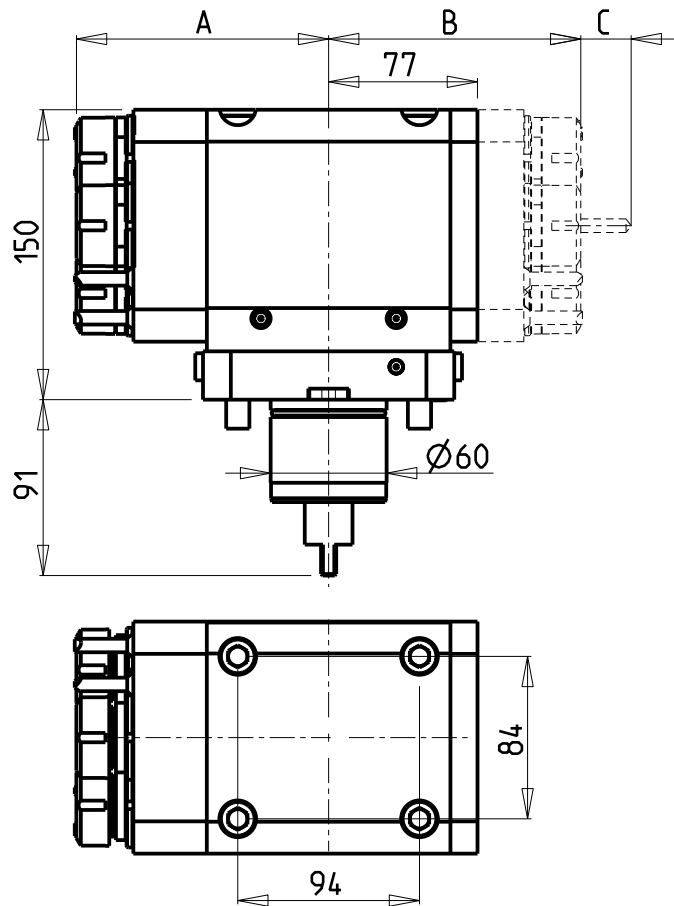

ATTENZIONE - ATTENTION - ACHTUNG

- Per lo smontaggio degli utensili utilizzare sempre la chiave di contrasto come indicato nel manuale d'uso.
- For disassembly of the tools use always the contrast key as mentioned in the user instructions.
- Fuer das Abmontieren der Werkzeuge immer den Gegenschlüssel benutzen wie in der Bedienungsanleitung erwäehnt.

Cod. MT	Mandrino Spindle Spindel	I	RPM	Coppia Max Max Torque Max Drehmoment	N°Utensili N°Tools N°Werkzeuge	Reversibile lato mandrino/contromandrino Reversible sub/main spindle side Umkehrbare Spindel-seite/ Gegenspindel-seite	Lubr.esterna Ext. coolant Aussehenkehlung	A	B	C max Lato contromandrino Subspindle side Gegenspindel-seite	CHIAVI INCLUSE Keys included Schluessel inbegriffen	
MNL0230425	ER25	1:1	6000	30Nm	4	X	X	130.46	-	-	MNL0210007	MNL0210008
MNL0234425	ER25+ER25	1:1	6000	30Nm	4+4		X	130.46	130.46	36	MNL0210007	MNL0210008

TAKISAWA
 MOD: TS3000/4000/5000 Y/YS 12 ST. (3 KEYS TURRET)
 MODULO MOTORIZZATO ASSIALE 4/8 USCITE
 Axial multiple 4/8 outlet driven tool
 Axial angetriebenes Mehrspindel-Werkzeug 4/8 Ausgaenge

Subject to change without notice.

M.T. srl
 Via Casino Albini 480
 Tel. 0541/956034-957884
 Fax 0541/956341
 47842 S. GIOVANNI IN M. (RN)
 e-mail: mtma@mtmarchetti.com
 http://www.mtmarchetti.com

PRODUZIONE MODULI ROTANTI



PAGINA TKW 270-7-00

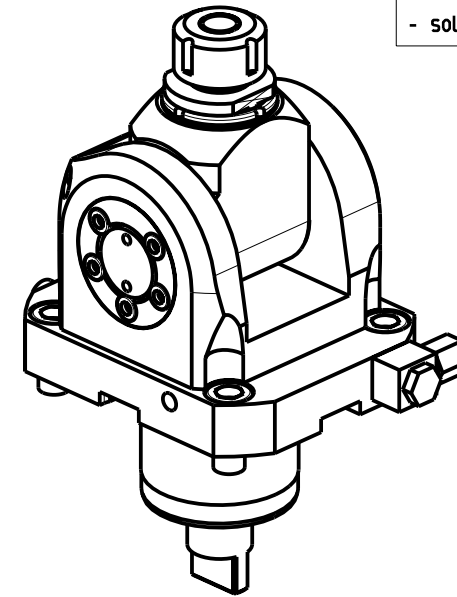
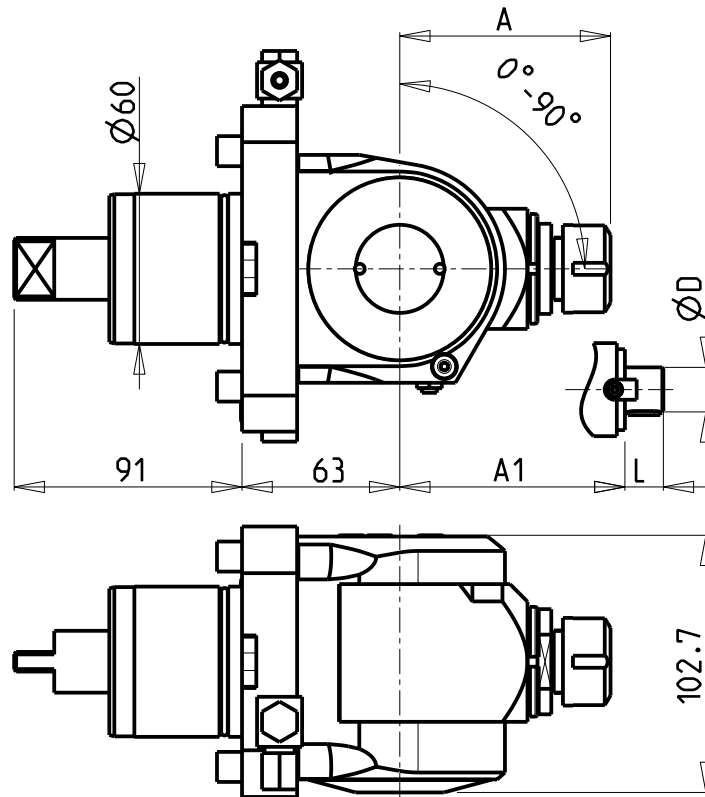
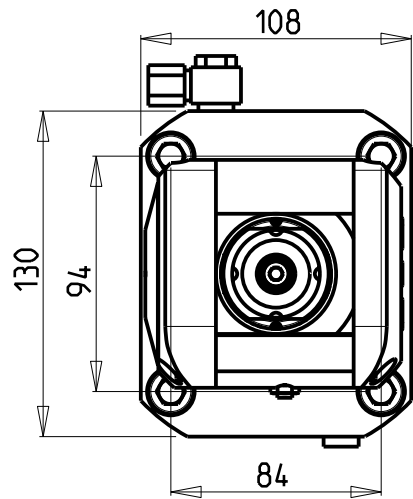

ATTENZIONE - ATTENTION - ACHTUNG

- FINO AD ESAURIMENTO SCORTE
- clearance sale
- solange vorrat

Cod. MT	Mandrino Spindle Spindel	I	RPM	Coppia Max Max Torque Max Drehmoment	Reversibile lato mandrino/contromandrino Reversible sub/main spindle side Umkehrbare Spindel-seite/ Gegenspindel-seite	Lubr. esterna Ext. coolant Aussenkuehlung	A	A1	D	L	CHIAVI INCLUSE Keys included Schluessel inbegriffen		
											CHUB36	CHSTER20	CHESL10
MNL0170020	ER20	1:1	6000	40Nm	X	X	84.16	-	-	-	CHUB36	CHSTER20	CHESL10
MNL0170025	ER25	1:1	6000	40Nm	X	X	85.66	-	-	-	CHUB36	CHSTER25	CHESL10
MNL0171617	Ø16x17	1:1	6000	40Nm	X	X	-	65	16	17	CHUB36	CH_VTCROCE_M08	CHESL10
MNL0172219	Ø22x19	1:1	6000	40Nm	X	X	-	66	22	19	CHUB36	CH_VTCROCE_M10	CHESL10
MNL0171905	Ø3/4"x3/4"	1:1	6000	40Nm	X	X	-	65	3/4"	3/4"	CHUB36	CH_VTCROCE_M08	CHESL10

TAKISAWA

MOD: TS3000/4000/5000 Y/YS 12 ST. (3 KEYS TURRET)

MODULO MOTORIZZATO ORIENTABILE 0-90°

0-90° adjustable angle driven tool

Angetriebenes Werkzeug schwenkbar 0-90°

Subject to change without notice.

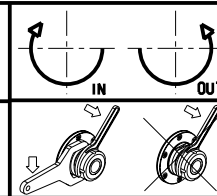

M.T. srl

Via Casino Albini 480
Tel. 0541/956034-957884

Fax 0541/956341

47842 S. GIOVANNI IN M. (RN)
e-mail: mtma@mtmarchetti.com
http://www.mtmarchetti.com

PRODUZIONE MODULI ROTANTI



PAGINA TKW 330-7-00

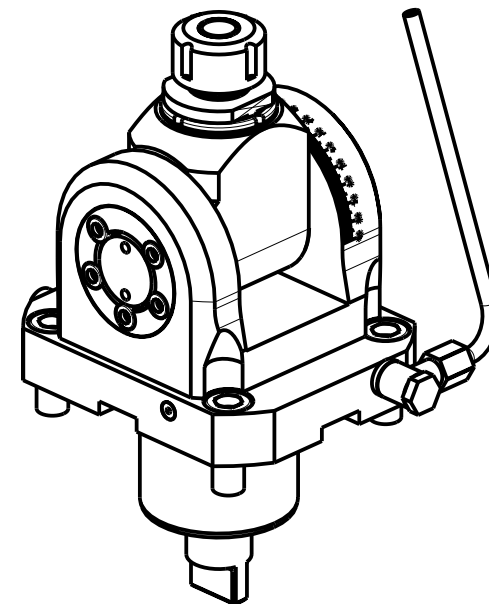
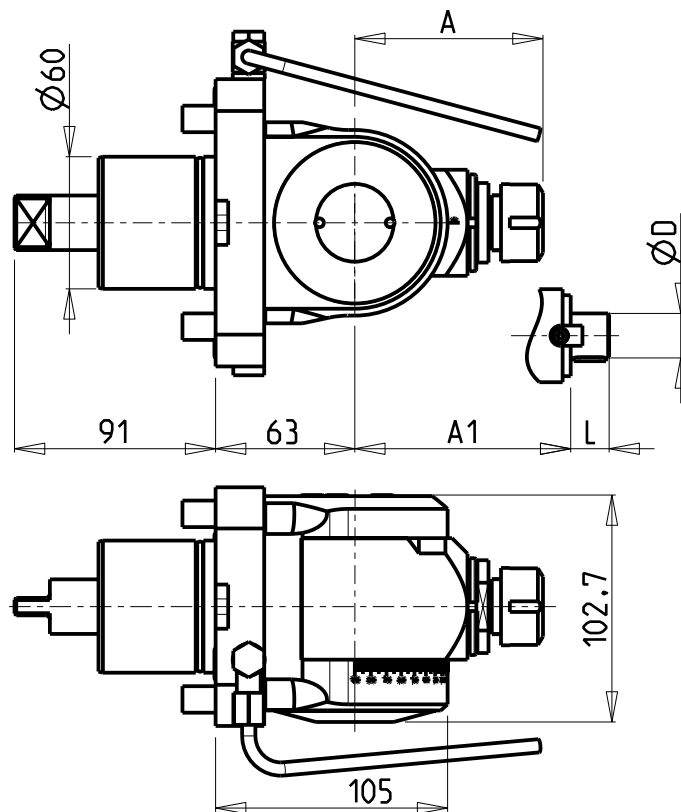
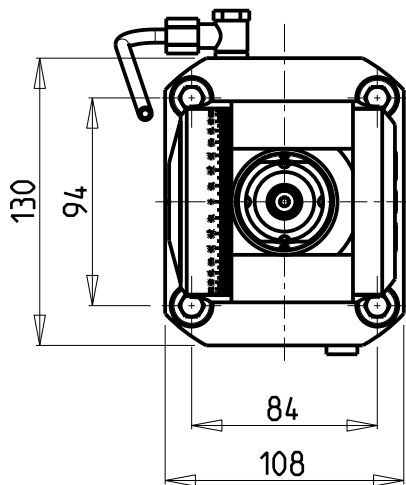

Cod. MT	Mandrino Spindle Spindel	i	RPM	Coppia Max Max Torque Max Drehmoment	Reversibile lato mandrino/contromandrino Reversible sub/main spindle side Umkehrbare Spindelsete/Gegenspindelsete	Lubr. esterna Ext. coolant Aussenkuehlung	A	A1	D	L	CHIAVI INCLUSE Keys included Schluessel inbegriffen		
											CHUB36	CHSTER	CHESL10
MNL0930120	ER20	1:1	6000	40Nm	X	X	85.16	-	-	-	CHUB36	CHSTER20	CHESL10
MNL0930125	ER25	1:1	6000	40Nm	X	X	86.16	-	-	-	CHUB36	CHSTER25	CHESL10
MNL0930516	∅16x17	1:1	6000	40Nm	X	X	-	65	16	17	CHUB36	CH_VTCROCE_M08	CHESL10
MNL0930522	∅22x19	1:1	6000	40Nm	X	X	-	66	22	19	CHUB36	CH_VTCROCE_M10	CHESL10
MNL0930519	∅3/4"x3/4"	1:1	6000	40Nm	X	X	-	65	3/4"	3/4"	CHUB36	CH_VTCROCE_M08	CHESL10

TAKISAWA

MOD: TS3000/4000/5000 Y/YS 12 ST. (3 KEYS TURRET)

MODULO MOTORIZZATO ORIENTABILE ±90°

±90° adjustable angle driven tool

Angetriebenes Werkzeug schwenkbar ±90°

Subject to change without notice.

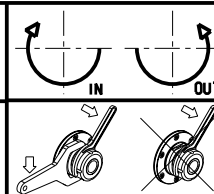

M.T. srl

Via Casino Albini 480

Tel. 0541/956034-957884

Fax 0541/956341

47842 S. GIOVANNI IN M. (RN)

e-mail: mtma@mtmarchetti.com

http://www.mtmarchetti.com

PRODUZIONE MODULI ROTANTI



PAGINA TKW 333-7-00

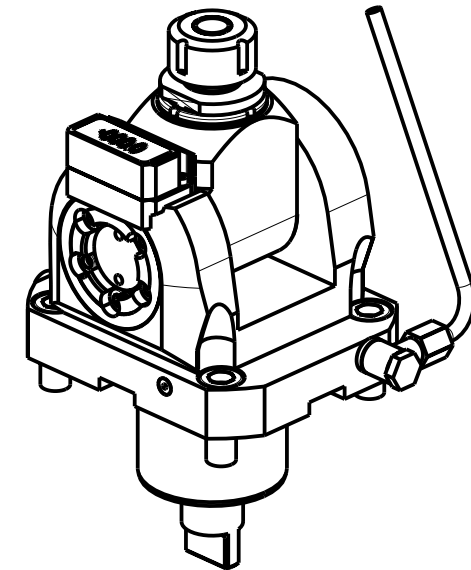
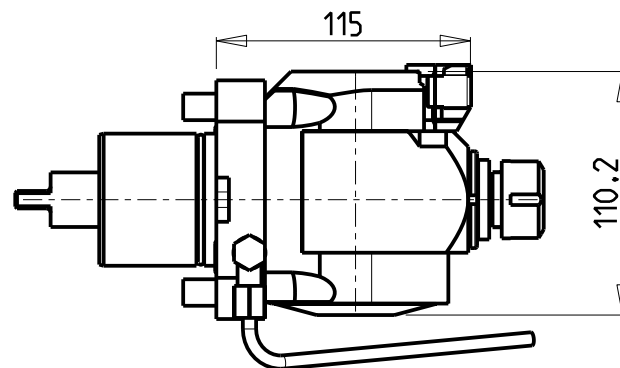
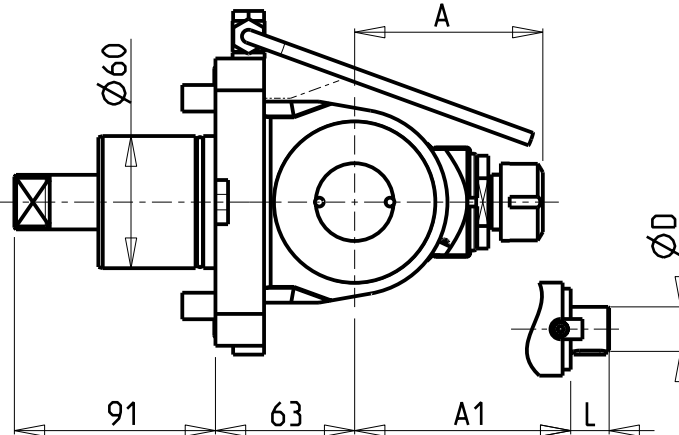
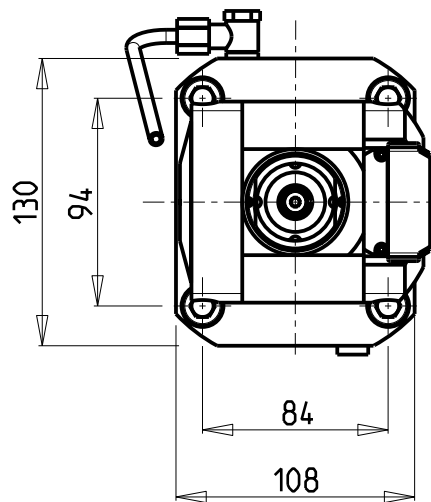

Cod. MT	Mandrino Spindle Spindel	i	RPM	Coppia Max Max Torque Max Drehmoment	Reversibile lato mandrino/contromandrino Reversible sub/main spindle side Umkehrbare Spindel-seite/ Gegenspindel-seite	Lubr.esterna Ext. coolant Aussenkuehlung	A	A1	D	L	CHIAVI INCLUSE Keys included Schluessel inbegriffen		
											CHUB36	CHSTER20	CHESL10
MNL0890120	ER20	1:1	6000	40Nm	X	X	85.16	-	-	-	CHUB36	CHSTER20	CHESL10
MNL0890125	ER25	1:1	6000	40Nm	X	X	86.16	-	-	-	CHUB36	CHSTER25	CHESL10
MNL0890516	Ø16x17	1:1	6000	40Nm	X	X	-	65	16	17	CHUB36	CH_VTCROCE_M08	CHESL10
MNL0890522	Ø22x19	1:1	6000	40Nm	X	X	-	66	22	19	CHUB36	CH_VTCROCE_M10	CHESL10
MNL0890519	Ø3/4"x3/4"	1:1	6000	40Nm	X	X	-	65	3/4"	3/4"	CHUB36	CH_VTCROCE_M08	CHESL10

TAKISAWA

MOD: TS3000/4000/5000 Y/YS 12 ST. (3 KEYS TURRET)

MODULO MOTORIZZATO ORIENTABILE ±90° CON NONIO DIGITALE

±90° adjustable angle driven tool with digital display

Angetriebenes Werkzeug schwenkbar ±90° mit digital display

Subject to change without notice.

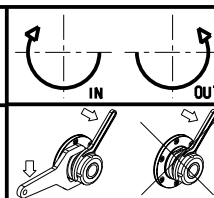

M.T. srl

Via Casino Albini 480
Tel. 0541/956034-957884

Fax 0541/956341

47842 S. GIOVANNI IN M. (RN)

e-mail: mtma@mtmarchetti.com

http://www.mtmarchetti.com

PRODUZIONE MODULI ROTANTI



PAGINA TKW 333-7-01

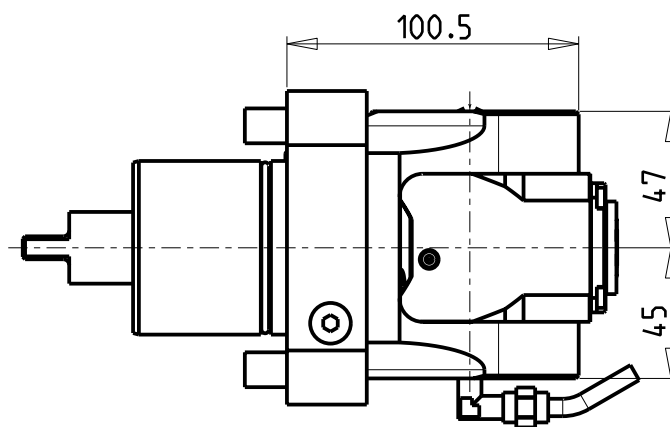
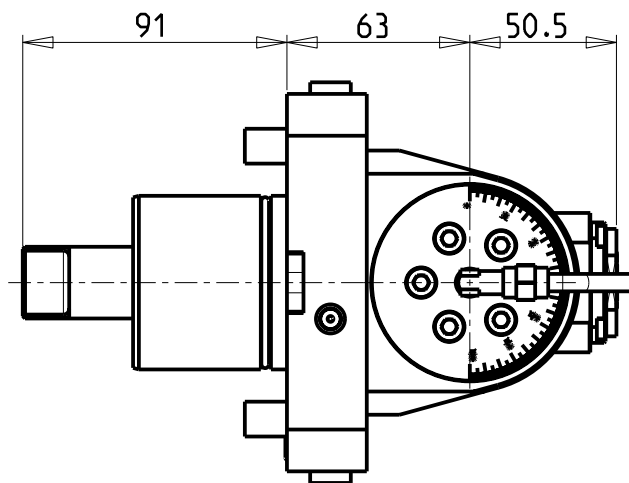
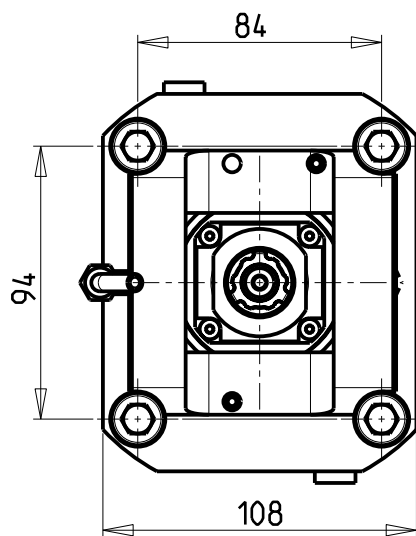

ATTENZIONE - ATTENTION - ACHTUNG

- Per lo smontaggio degli utensili utilizzare sempre la chiave di contrasto come indicato nel manuale d'uso.
- For disassembly of the tools use always the contrast key as mentioned in the user instructions.
- Fuer das Abmontieren der Werkzeuge immer den Gegenschlüssel benutzen wie in der Bedienungsanleitung erwäehnt.

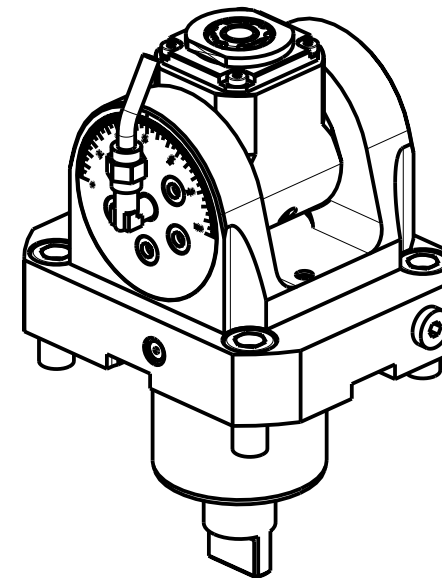

Cod. MT	Mandrino Spindle Spindel	I	RPM	Coppia Max Max Torque Max Drehmoment	Lubrificazione int. Coolant through Innenkuehlung	Lubrificazione est. Ext. coolant Aussenkuehlung	CHIAVI INCLUSE Keys included Schluessel inbegriffen			
MNL0640120	ERA20	1:1	6000	30Nm		X	CHUB22	CHUB36	CHTAER20ZC	CHESL10
MNL0640220	ERA20	1:1	6000	30Nm	P=70bar	X	CHUB22	CHUB36	CHTAER20ZC	CHESL10

TAKISAWA

MOD: TS3000/4000/5000 Y/YS 12 ST. (3 KEYS TURRET)

MODULO MOTORIZZATO ORIENTABILE +/-90°

+/-90° adjustable angle driven tool

Angetriebenes Werkzeug schwenkbar +/-90°

Subject to change without notice.

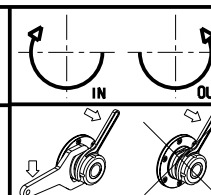

M.T. srl

Via Casino Albini 480
Tel. 0541/956034-957884
Fax 0541/956341
47842 S. GIOVANNI IN M. (RN)
e-mail: mtma@mtmarchetti.com
http://www.mtmarchetti.com

PRODUZIONE MODULI ROTANTI



PAGINA TKW 335-7-00

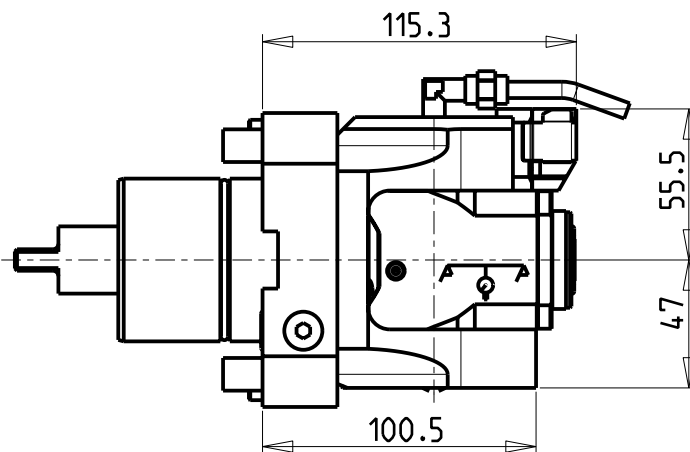
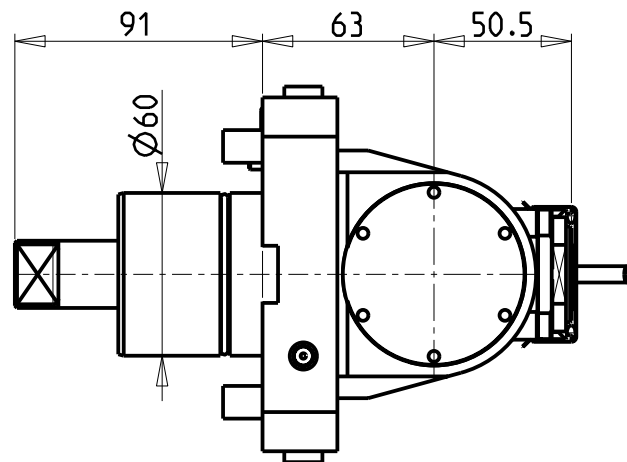
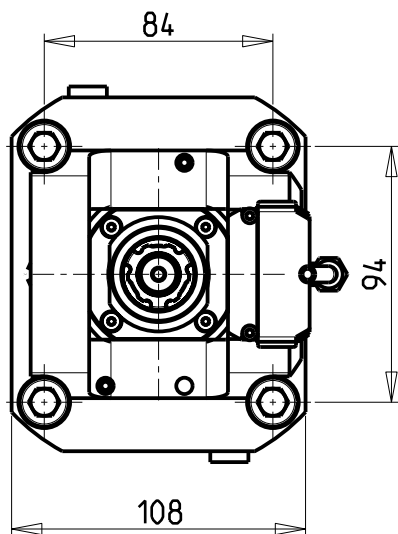

ATTENZIONE - ATTENTION - ACHTUNG

- Per lo smontaggio degli utensili utilizzare sempre la chiave di contrasto come indicato nel manuale d'uso.
- For disassembly of the tools use always the contrast key as mentioned in the user instructions.
- Fuer das Abmontieren der Werkzeuge immer den Gegenschlüssel benutzen wie in der Bedienungsanleitung erwaeht.

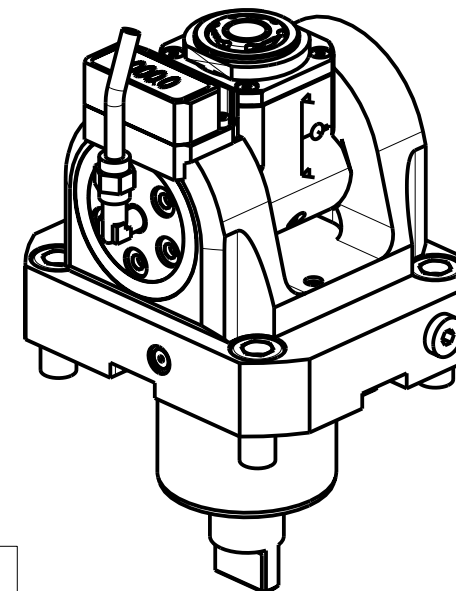

Cod. MT	Mandrino Spindle Spindel	I	RPM	Coppia Max Max Torque Max Drehmoment	Lubrificazione int. Coolant through Innenkuehlung	Lubrificazione est. Ext. coolant Ausseenkuehlung	CHIAVI INCLUSE Keys included Schluessel inbegriffen			
MNL0645120	ERA20	1:1	6000	30Nm	-	X	CHUB22	CHUB36	CHTAER20ZC	CHESL10
MNL0645220	ERA20	1:1	6000	30Nm	P=70bar	X	CHUB22	CHUB36	CHTAER20ZC	CHESL10

TAKISAWA

MOD: TS3000/4000/5000 Y/YS 12 ST. (3 KEYS TURRET)

MODULO MOTORIZZATO ORIENTABILE +/-90° CON NONIO DIGITALE

+/-90° adjustable angle driven tool with digital display

Angetriebenes Werkzeug schwenkbar +/-90° mit digital display

Subject to change without notice.

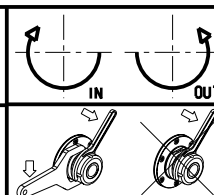

M.T. srl

Via Casino Albini 480
Tel. 0541/956034-957884
Fax 0541/956341
47842 S. GIOVANNI IN M. (RN)
e-mail: mtma@mtmarchetti.com
http://www.mtmarchetti.com

PRODUZIONE MODULI ROTANTI



PAGINA TKW 335-7-01

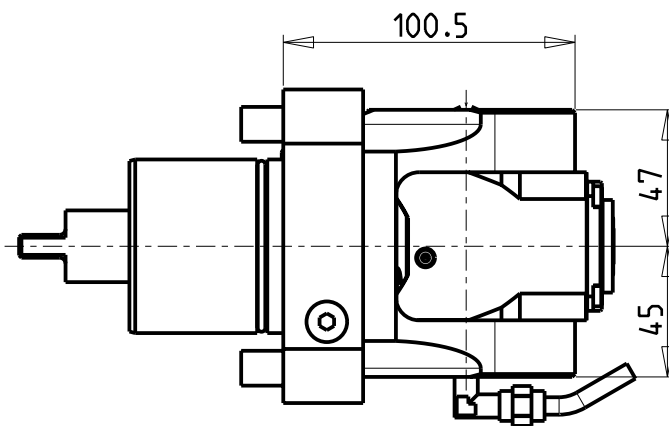
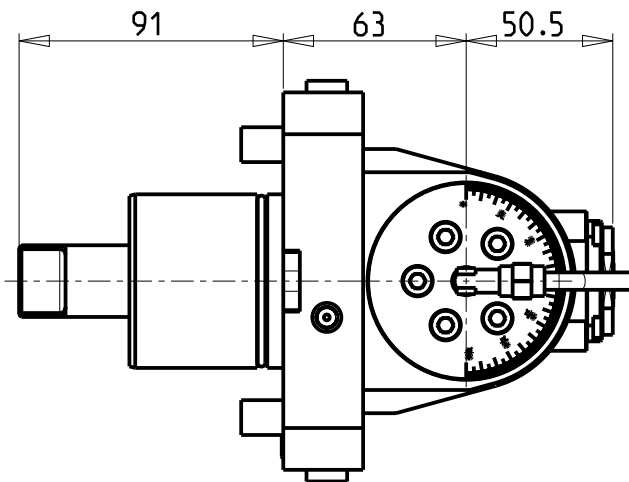
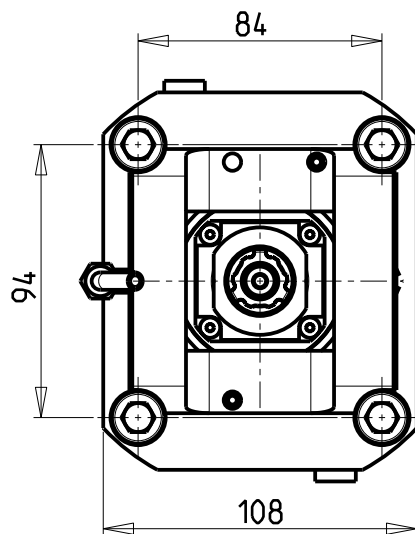

ATTENZIONE - ATTENTION - ACHTUNG

- Per lo smontaggio degli utensili utilizzare sempre la chiave di contrasto come indicato nel manuale d'uso.
- For disassembly of the tools use always the contrast key as mentioned in the user instructions.
- Fuer das Abmontieren der Werkzeuge immer den Gegenschlüssel benutzen wie in der Bedienungsanleitung erwaeht.

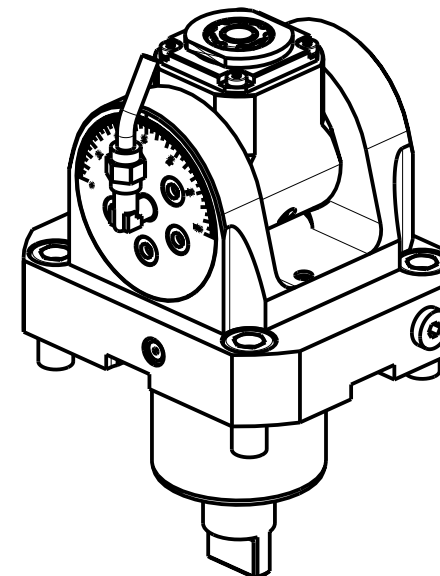

Cod. MT	Mandrino Spindle Spindel	I	RPM	Coppia Max Max Torque Max Drehmoment	Lubrificazione int. Coolant through Innenkuehlung	Lubrificazione est. Ext. coolant Aussenkuehlung	CHIAVI INCLUSE Keys included Schluessel inbegriffen			
							C HUB19_SP3	C HUB32	C HTAER16ZC	C HESL10
MNL0640316	ERA16	1:2	12000	8Nm		X	C HUB19_SP3	C HUB32	C HTAER16ZC	C HESL10
MNL0640416	ERA16	1:2	12000	8Nm	P=70bar	X	C HUB19_SP3	C HUB32	C HTAER16ZC	C HESL10

TAKISAWA

MOD: TS3000/4000/5000 Y/YS 12 ST. (3 KEYS TURRET)

MODULO MOTORIZZATO ORIENTABILE +/-90° MOLTIPLICATO I=1:2

+/-90° adjustable angle driven tool geared-up I=1:2

Angetriebenes Werkzeug schwenkbar +/-90° uebersetzt I=1:2

Subject to change without notice.

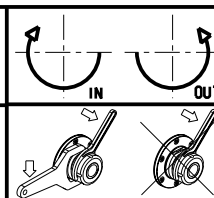

M.T. srl

Via Casino Albini 480
Tel. 0541/956034-957884
Fax 0541/956341

47842 S. GIOVANNI IN M. (RN)
e-mail: mtma@mtmarchetti.com
http://www.mtmarchetti.com

PRODUZIONE MODULI ROTANTI



PAGINA TKW 336-7-00

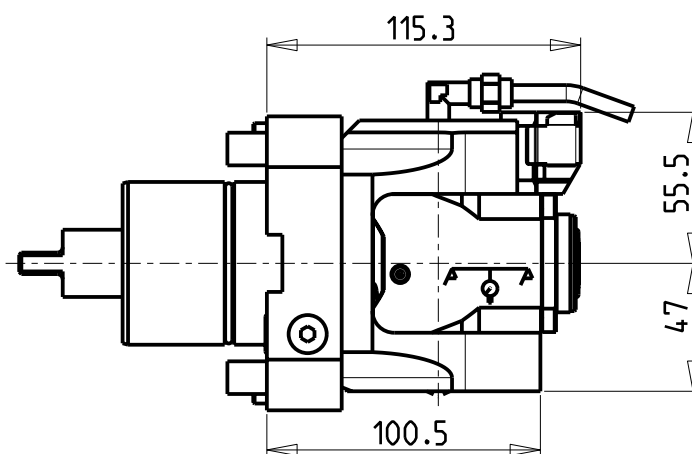
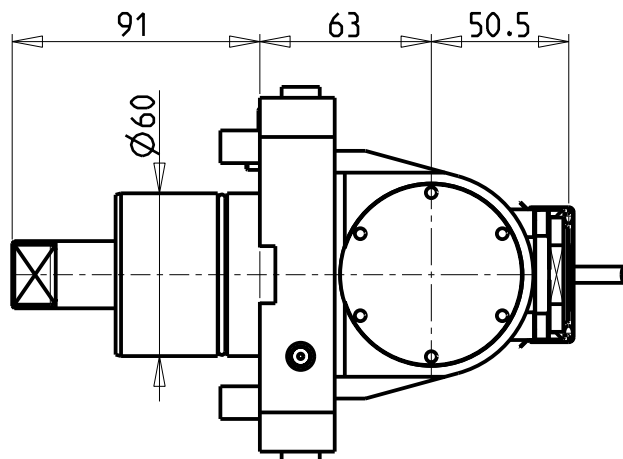
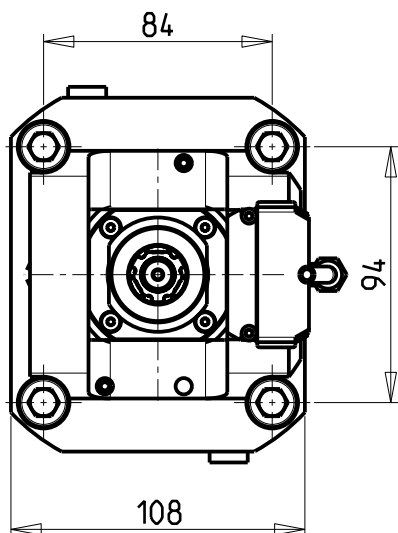

ATTENZIONE - ATTENTION - ACHTUNG

- Per lo smontaggio degli utensili utilizzare sempre la chiave di contrasto come indicato nel manuale d'uso.
- For disassembly of the tools use always the contrast key as mentioned in the user instructions.
- Fuer das Abmontieren der Werkzeuge immer den Gegenschlüssel benutzen wie in der Bedienungsanleitung erwäehnt.

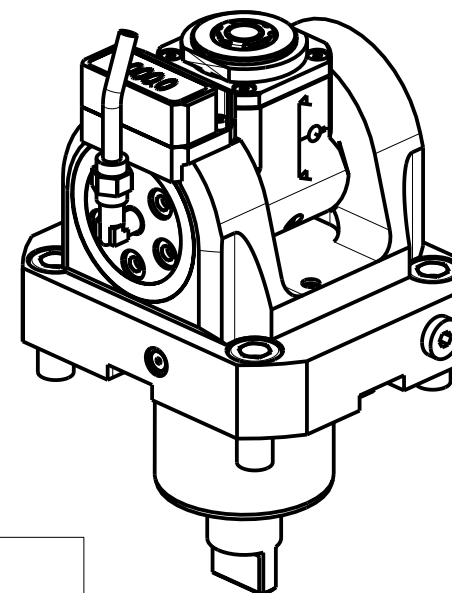

Cod. MT	Mandrino Spindle Spindel	I	RPM	Coppia Max Max Torque Max Drehmoment	Lubrificazione int. Coolant through Innenkuehlung	Lubrificazione est. Ext. coolant Aussenkuehlung	CHIAVI INCLUSE Keys included Schluessel inbegriffen			
MNL0645316	ERA16	1:2	12000	8Nm	-	X	CHUB19_SP3	CHUB32	CHTAER16ZC	CHESL10
MNL0645416	ERA16	1:2	12000	8Nm	P=70bar	X	CHUB19_SP3	CHUB32	CHTAER16ZC	CHESL10

TAKISAWA

MOD: TS3000/4000/5000 Y/YS 12 ST. (3 KEYS TURRET)

MODULO MOTORIZZATO ORIENTABILE +/-90° MOLTIPLICATO I=1:2 CON NONIO DIGITALE

+/-90° adjustable angle driven tool geared-up I=1:2 with digital display

Angetriebenes Werkzeug schwenkbar +/-90° uebersetzt I=1:2 mit digital display

Subject to change without notice.

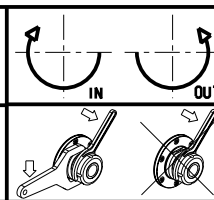

M.T. srl

Via Casino Albini 480
Tel. 0541/956034-957884
Fax 0541/956341
47842 S. GIOVANNI IN M. (RN)
e-mail: mtma@tmarchetti.com
http://www.mtmarchetti.com

PRODUZIONE MODULI ROTANTI



PAGINA TKW 336-7-01

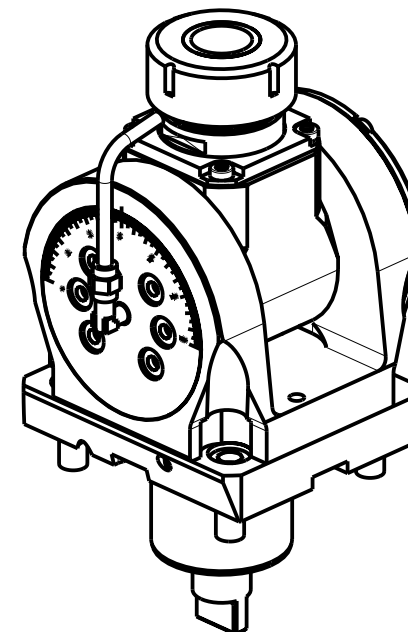
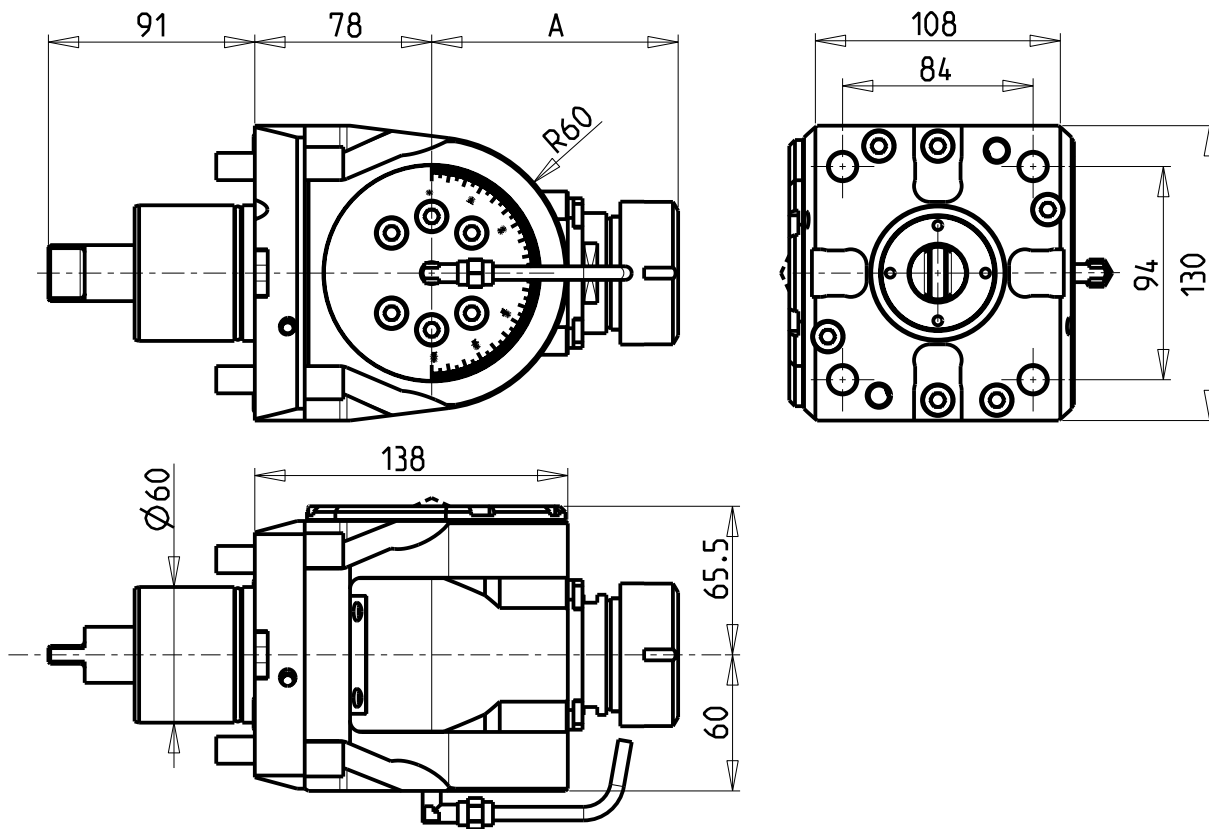

Cod. MT	Mandrino Spindle Spindel	I	RPM	Coppia Max Max Torque Max Drehmoment	Lubrificazione int. Coolant through Innenkuehlung	Lubrificazione est. Ext. coolant Aussenkuehlung	A	CHIAVI INCLUSE Keys included Schluessel inbegriffen				
MNL0660332	ERA32	1:1	6000	50Nm		X	81	CHUB30	CHUB46	CHTAER32ZC	CHESL10	CHESL06
MNL0660432	ERA32	1:1	6000	50Nm	P=70bar	X	81	CHUB30	CHUB46	CHTAER32ZC	CHESL10	CHESL06
MNL0660140	ER40	1:1	6000	50Nm		X	108.66	-	CHUB46	CHSTER40	CHESL10	CHESL06
MNL0660240	ER40	1:1	6000	50Nm	P=70bar	X	108.66	-	CHUB46	CHSTER40	CHESL10	CHESL06

TAKISAWA

MOD: TS3000/4000/5000 Y/YS 12 ST. (3 KEYS TURRET)

MODULO MOTORIZZATO ORIENTABILE +/-90°

+/-90° adjustable angle driven tool

Angetriebenes Werkzeug schwenkbar +/-90°

Subject to change without notice.

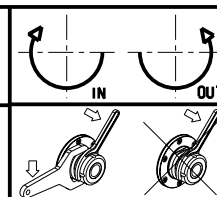

M.T. srl

Via Casino Albini 480
Tel. 0541/956034-957884
Fax 0541/956341

47842 S. GIOVANNI IN M. (RN)
e-mail: mtma@mtmarchetti.com
http://www.mtmarchetti.com

PRODUZIONE MODULI ROTANTI



PAGINA TKW 339-7-00

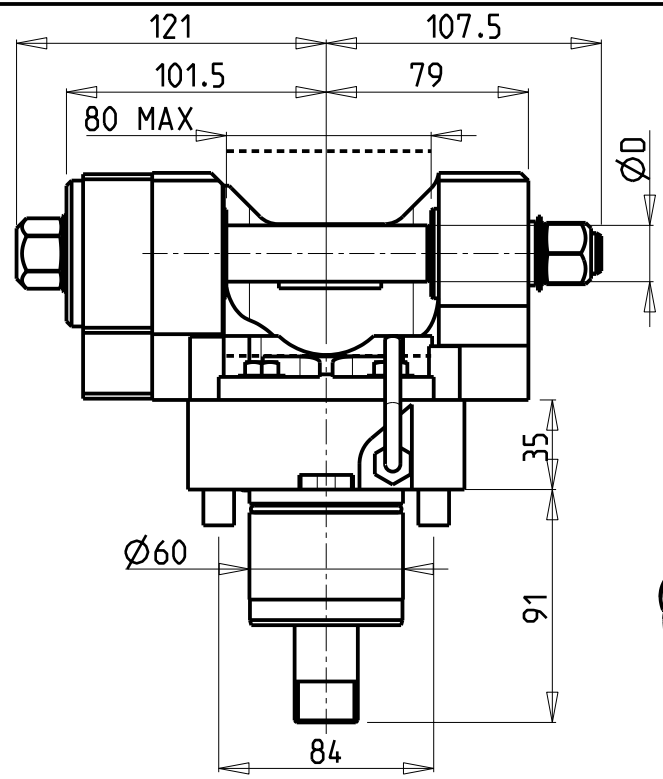
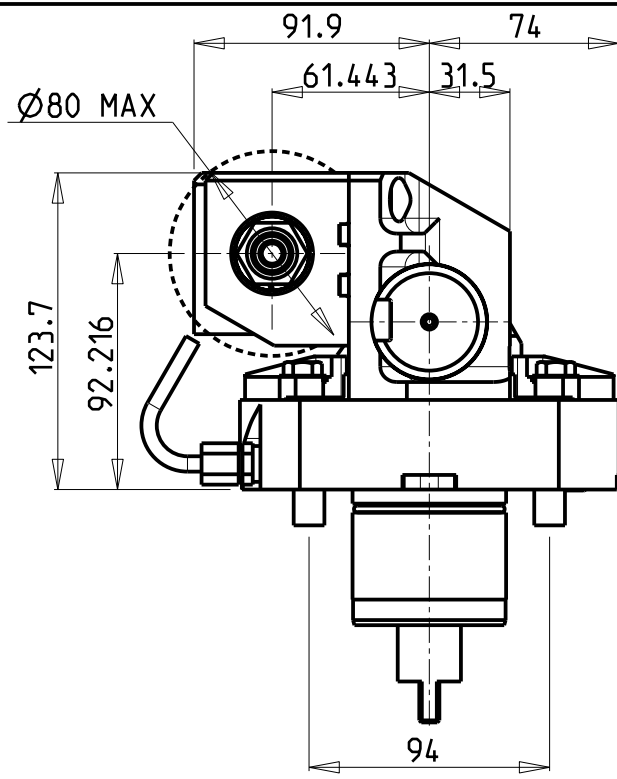

- SU RICHIESTA E' DISPONIBILE UNA STAFFA ANTIROTAZIONE PER LAVORAZIONI PESANTI
- On request we arrange antirotationscrew for heavy working
- Auf Anfrage verfuegen wir ueber Antirotationbolzen fuer schwere Verarbeitungen

INCLINAZIONE REGOLABILE ±20°

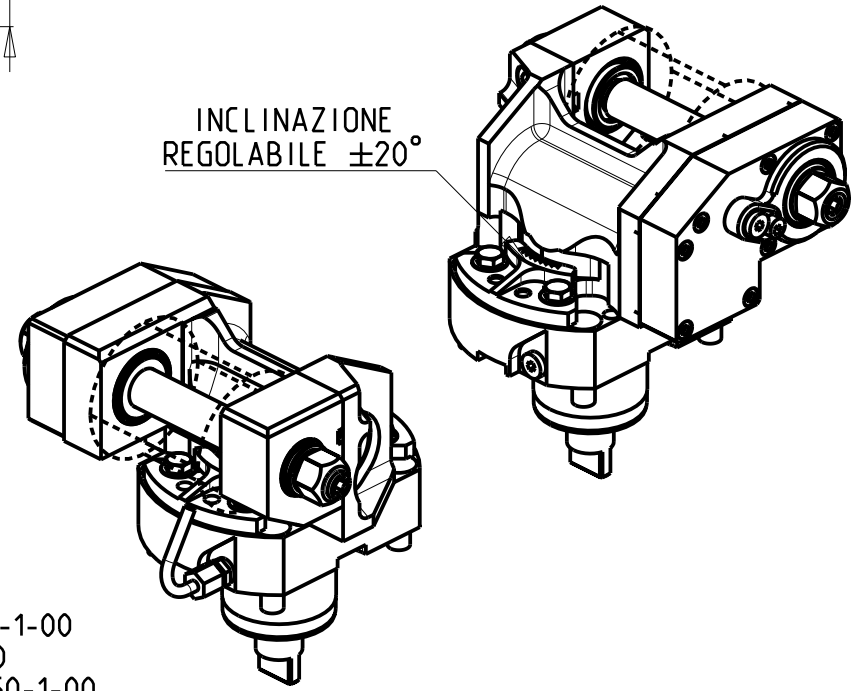

DOTAZIONI - SUPPLIED WITH - AUSSTATTUNG

- | | |
|-----------|---|
| mm / inch | - N°1 ALBERO + DISTANZIALI
- N°1 SHAFT + SPACER
- N°1 DORN + ABSTANDSSTUECK |
|-----------|---|

PER ALBERI E DISTANZIALI VEDI PAG. TBL250-1-00
FOR SHAFT END SPACER SEE PAGE TBL250-1-00
FUER DORN UND ABSTANDSSTUECK SEITE TBL250-1-00

Cod. MT	i	RPM max	Coppia Max Max Torque Max Drehmoment	Reversibile lato mandrino/contromandrino Reversible sub/main spindle side Umkehrbare Spindel-seite/ Gegenspindel-seite	Lubrificazione est. Ext. coolant Aussenkuehlung	D		CHIAVI INCLUSE Keys included Schlüssel inbegriffen			
						(mm)	(Inch)	CHUB24	CHUB13	CHESL08	CHESL10
MNL0151100	1:1	6000	60Nm	X	X	16-22-27-32	3/4"-1"-1 1/4"	CHUB24	CHUB13	CHESL08	CHESL10
MNL0152100	2:1	3000	80Nm	X	X	16-22-27-32	3/4"-1"-1 1/4"	CHUB24	CHUB13	CHESL08	CHESL10

TAKISAWA
MOD: TS3000/4000/5000 Y/YS 12 ST. (3 KEYS TURRET)

MODULO MOTORIZZATO PORTACREATORE
Driven gear hobber
Angetriebenes Zahnradwaeltzraes-Werkzeug

Subject to change without notice.

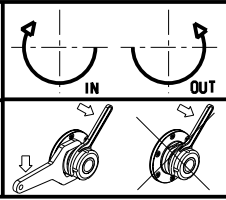

M.T. srl
Via Casino Albini 480
Tel. 0541/956034-957884
Fax 0541/956341
47842 S. GIOVANNI IN M. (RN)
e-mail: mtma@mtmarchetti.com
http://www.mtmarchetti.com

PRODUZIONE MODULI ROTANTI

PAGINA TKW 340-7-00

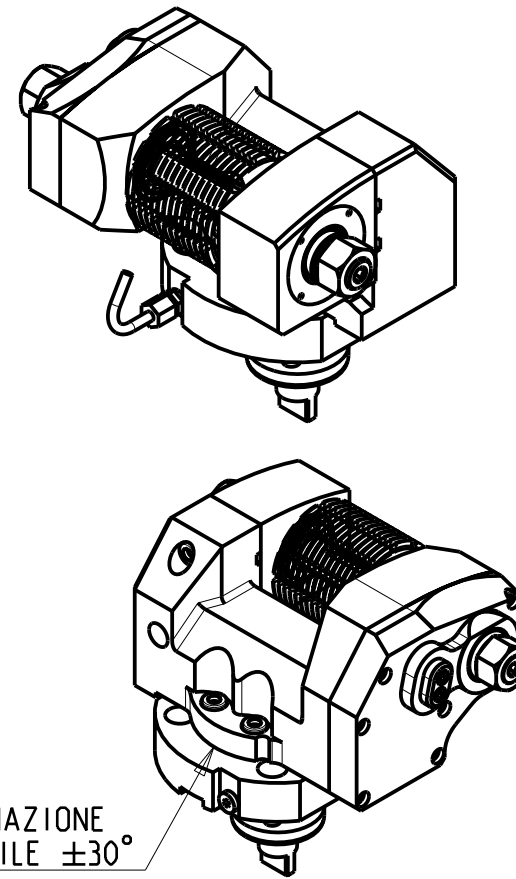
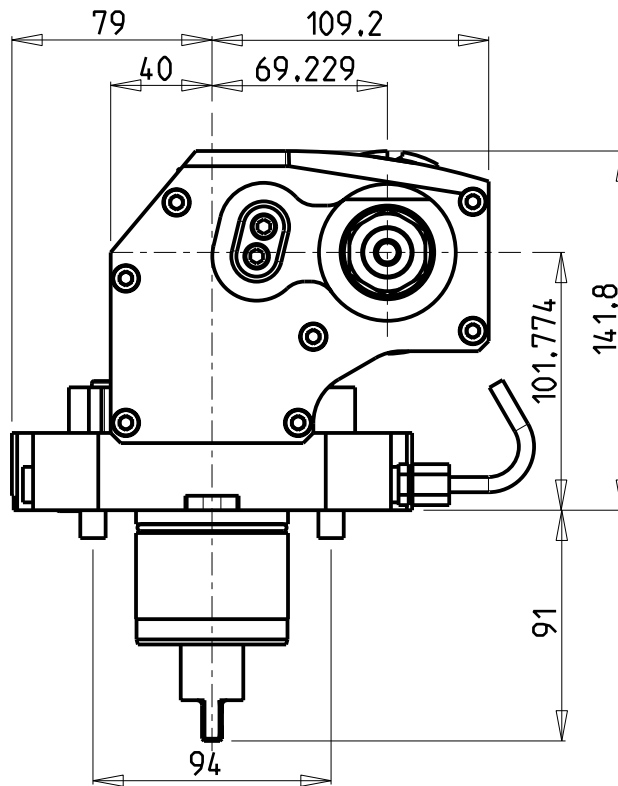
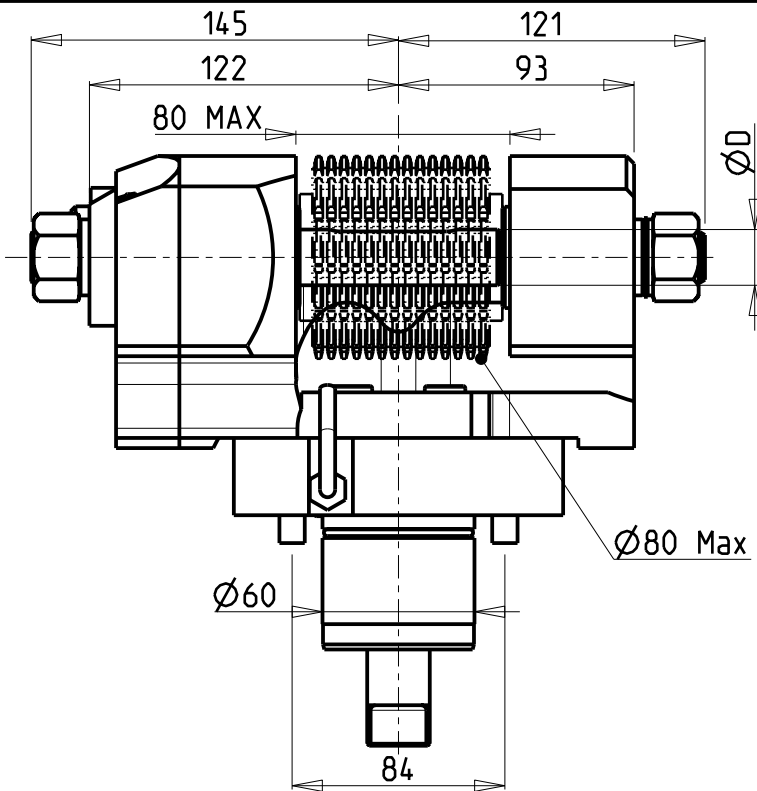

INCLINAZIONE
REGOLABILE $\pm 30^\circ$

DOTAZIONI - SUPPLIED WITH - AUSSTATTUNG

- | mm / inch | |
|-----------|-----------------------------|
| | - N°1 ALBERO + DISTANZIALI |
| | - N°1 SHAFT + SPACER |
| | - N°1 DORN + ABSTANDSSTUECK |

PER ALBERI E DISTANZIALI VEDI PAG. TBL250-1-00
FOR SHAFT END SPACER SEE PAGE TBL250-1-00
FUER DORN UND ABSTANDSSTUECK SEITE TBL250-1-00

Cod. MT	i	RPM max	Coppia Max Max Torque Max Drehmoment	Lubrificazione est. Ext. coolant Aussenkuehlung	D (mm)	D (Inch)	CHIAVI INCLUSE Keys included Schlüssel inbegriffen			
							CHUB30	CHESL08	CHESL10	CHUB24 (Ø16 / Ø3/4")
MNL0411100	1:1	6000	90Nm	X	16-22-27-32	3/4"-1"-1 1/4"	CHUB30	CHESL08	CHESL10	CHUB24 (Ø16 / Ø3/4")
MNL0412100	2:1	3000	110Nm	X	16-22-27-32	3/4"-1"-1 1/4"	CHUB30	CHESL08	CHESL10	CHUB24 (Ø16 / Ø3/4")

TAKISAWA

MOD: TS3000/4000/5000 Y/YS 12 ST. (3 KEYS TURRET)

MODULO MOTORIZZATO PORTACREATORE MAGGIORATO

Reinforced driven gear hobber

Angetriebenes Zahnradwaelzfraes-Werkzeug vergroessert

Subject to change without notice.

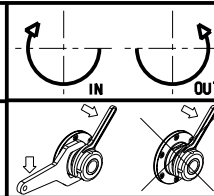

M.T. srl

Via Casino Albini 480
Tel. 0541/956034-957884

Fax 0541/956341

47842 S. GIOVANNI IN M. (RN)
e-mail: mtma@mtmarchetti.com
http://www.mtmarchetti.com

PRODUZIONE MODULI ROTANTI



PAGINA TKW 340-7-60

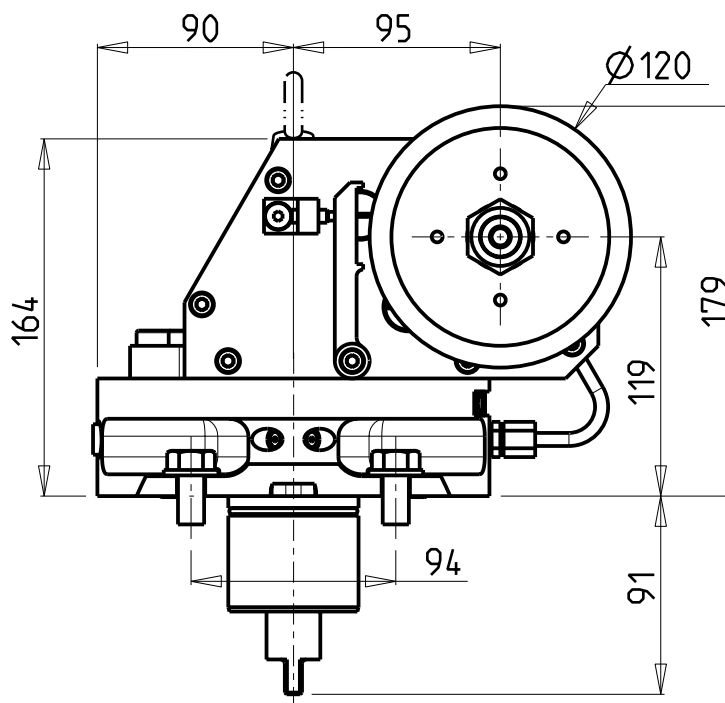
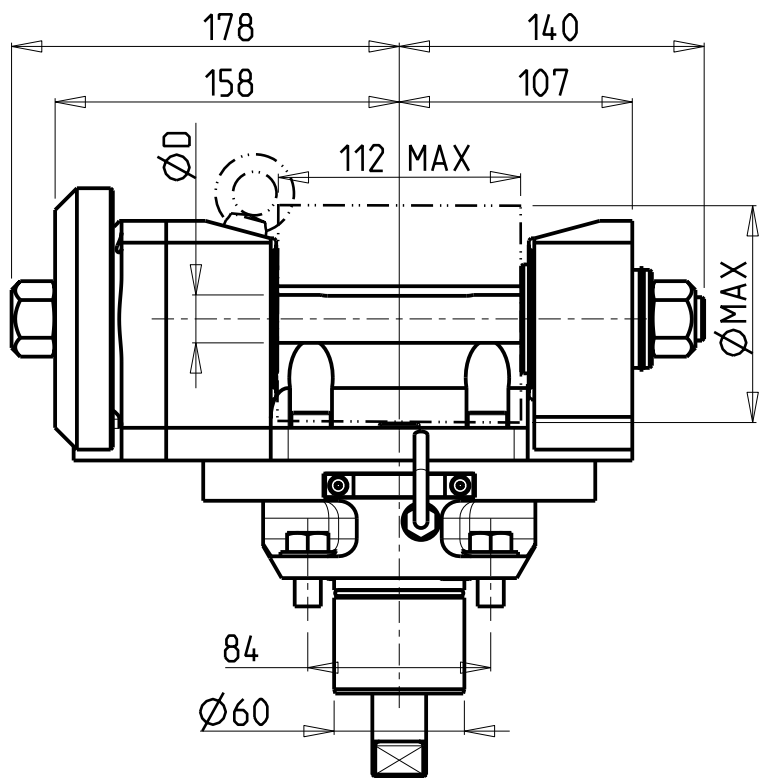

D (mm)	ØMAX (mm)
22	89
27-32	100

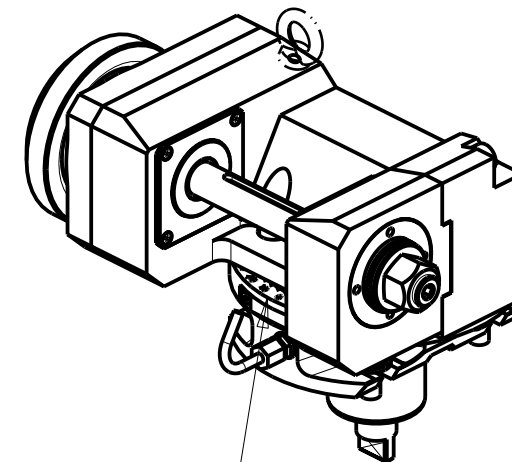

INCLINAZIONE
REGOLABILE ±180°

DOTAZIONI - SUPPLIED WITH - AUSSTATTUNG

- | mm / inch | |
|-----------|-----------------------------|
| | - N°1 ALBERO + DISTANZIALI |
| | - N°1 SHAFT + SPACER |
| | - N°1 DORN + ABSTANDSSTUECK |

PER ALBERI E DISTANZIALI VEDI PAG. TBL250-1-00
FOR SHAFT END SPACER SEE PAGE TBL250-1-00
FUER DORN UND ABSTANDSSTUECK SEITE TBL250-1-00

Cod. MT	i	RPM max	Coppia Max Max Torque Max Drehmoment	Lubrificazione est. Ext. coolant Aussenkuehlung	D (mm)	CHIAVI INCLUSE Keys included Schluessel inbegriffen			
						CHUB30	CHESL08	CHESL10	CHUB19
MNL0671100	1:1	6000	110Nm	X	22-27-32	CHUB30	CHESL08	CHESL10	CHUB19
MNL0672100	2:1	3000	130Nm	X	22-27-32	CHUB30	CHESL08	CHESL10	CHUB19

TAKISAWA

MOD: TS3000/4000/5000 Y/YS 12 ST. (3 KEYS TURRET)

MODULO MOTORIZZATO PORTACREATORE (TAGLIA GRANDE)

Driven gear hobber (big size)

Angetriebenes Zahnradwaeltzraes-Werkzeug (grosse version)

Subject to change without notice.

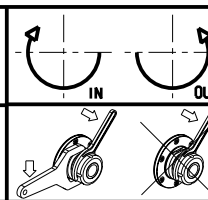

M.T. srl

Via Casino Albini 480
Tel. 0541/956034-957884
Fax 0541/956341
47842 S. GIOVANNI IN M. (RN)
e-mail: mtma@mtmarchetti.com
http://www.mtmarchetti.com

PRODUZIONE MODULI ROTANTI



PAGINA TKW 340-7-80

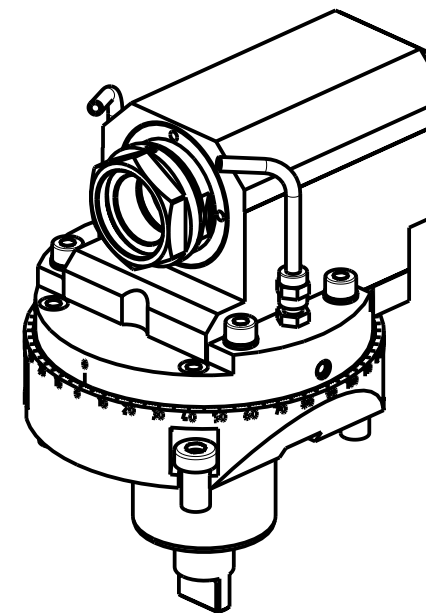
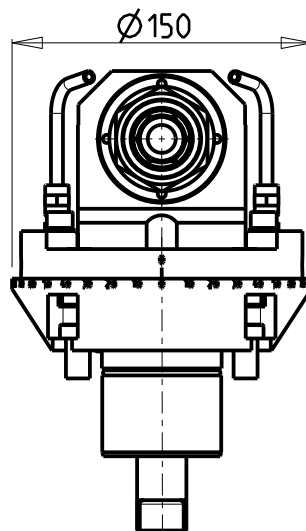
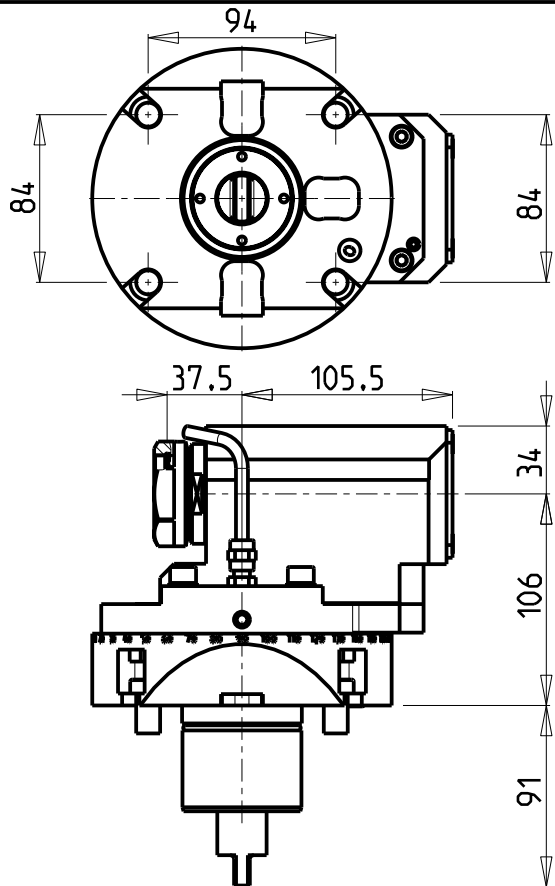

ATTENZIONE - ATTENTION - ACHTUNG

- VERIFICARE LE MISURE DI INGOMBRO PER POSSIBILE INTERFERENZA SU ALCUNI MODELLI DI MACCHINE
- Please check the overall sizes for possible interferences on some machine models
- Bitte überprüfen sie das ausmass um mögliche interferenzen auf einigen maschinen modellen zu vermeiden

PER PORTAUTENSILI MODULARI MTSK-40 VEDI PAG. TBL300-1-40
 FOR MTSK-40 QUICK CHANGE TOOLHOLDERS CLAMPINGS SEE PAGE TBL300-1-40
 FUER MTSK-40 MODULARE WERKZEUGAUFNAHMEN SIEHE SEITE TBL300-1-40

Cod. MT	Mandrino Spindle Spindel	I	RPM	Coppia Max Max Torque Max Drehmoment	Lubr.esterna Ext. coolant Aussenkuehlung	CHIAVI INCLUSE Keys included Schluessel einbegriffen
MNL0870100	MTSK-40	1:1	6000	50Nm	X	n°2 CHUB46

TAKISAWA

MOD: TS3000/4000/5000 Y/YS 12 ST. (3 KEYS TURRET)

MODULO MOTORIZZATO ASSIALE MTSK PER POWER SKIVING H=106mm

Axial MTSK driven tool for Power Skiving H=106mm

Axial MTSK angetriebenes Werkzeug fuer Power Skiving H=106mm

Subject to change without notice.

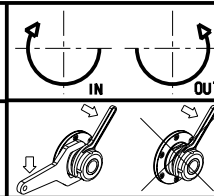

M.T. srl

Via Casino Albini 480
 Tel. 0541/956034-957884
 Fax 0541/956341
 47842 S. GIOVANNI IN M. (RN)
 e-mail: mtma@mtmarchetti.com
 http://www.mtmarchetti.com

PRODUZIONE MODULI ROTANTI



PAGINA TKW 350-7-00-K

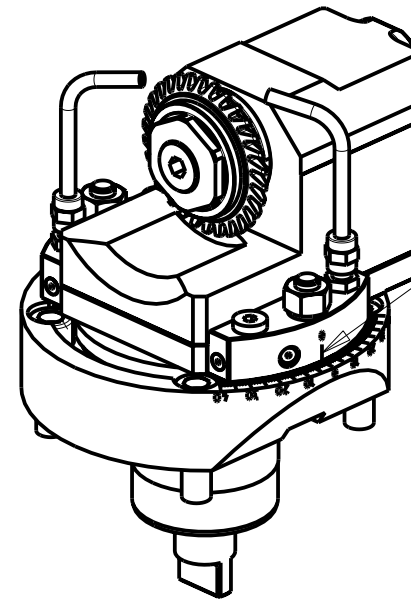
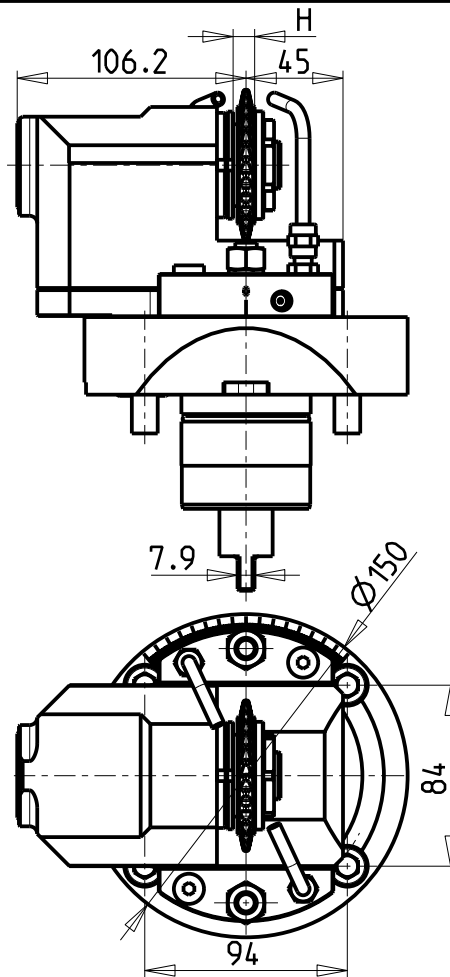
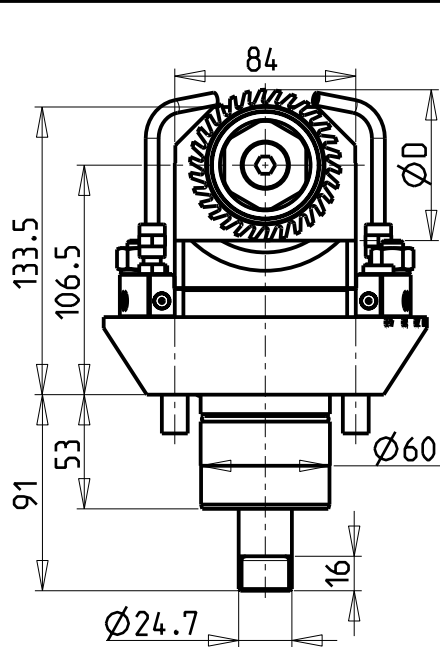

INCLINAZIONE
REGOLABILE $\pm 31^\circ$

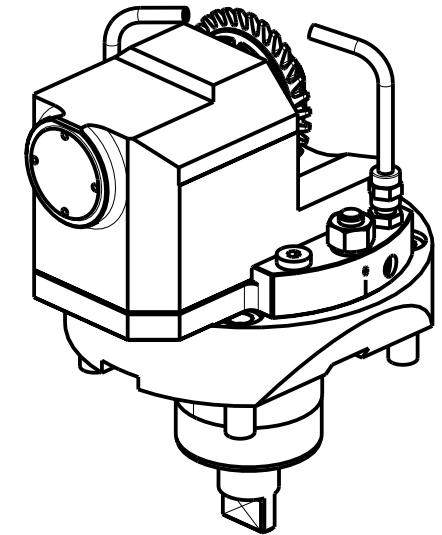

Cod. MT	Mandrino Spindle Spindel	i	RPM	Coppia Max Max Torque Max Drehmoment	Lubrificazione est. Ext. coolant Auslenkung	$\varnothing D$	H	CHIAVI INCLUSE Keys included Schlüssel einbegriffen			
MNL0378022	$\varnothing 22 \times 12$	1:1	6000	50Nm	X	63-70-80	MAX 12	CHUB38	CHUB17	CHESL10	CHESL08
MNL0378125	$\varnothing 1" \times 12$	1:1	6000	50Nm	X	63-70-80	MAX 12	CHUB38	CHUB17	CHESL10	CHESL08

TAKISAWA
MOD: TS3000/4000/5000 Y/YS 12 ST. (3 KEYS TURRET)

MODULO MOTORIZZATO PER VITI SENZA FINE

Driven tool for worm screws

Angetriebenes Werkzeug fuer schrauben ohne ende

Subject to change without notice.

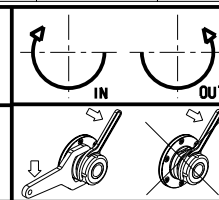

M.T. srl

Via Casino Albini 480
Tel. 0541/956034-957884
Fax 0541/956341
47842 S. GIOVANNI IN M. (RN)
e-mail: mtma@mtmarchetti.com
http://www.mtmarchetti.com

PRODUZIONE MODULI ROTANTI



PAGINA TKW 359-7-00

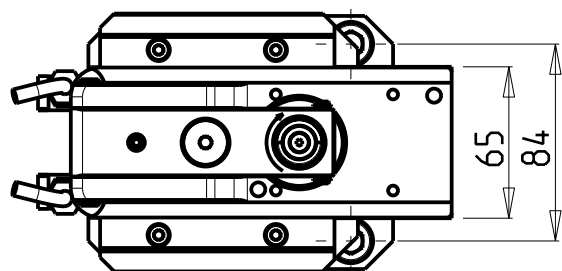
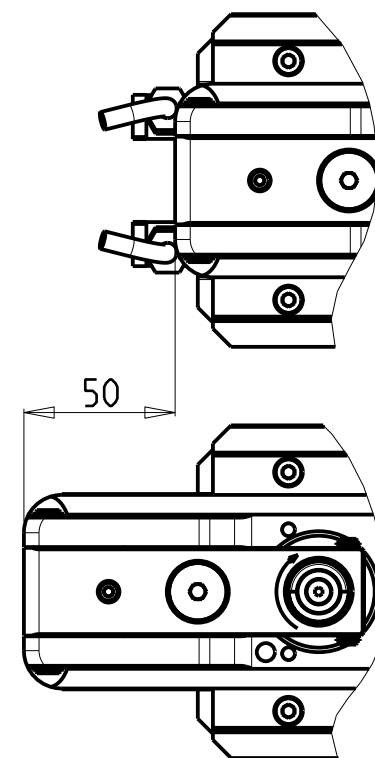
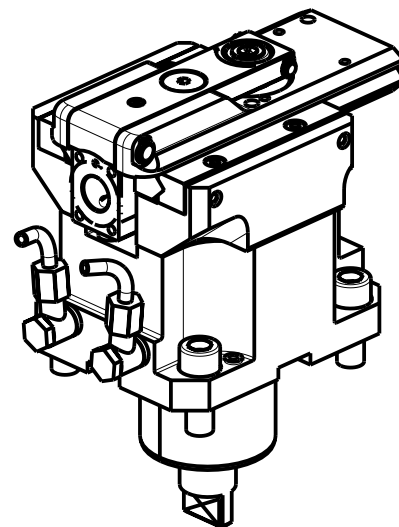
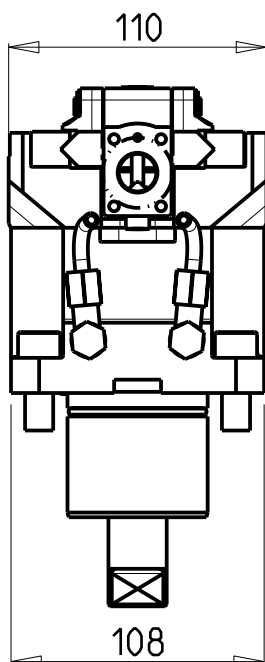
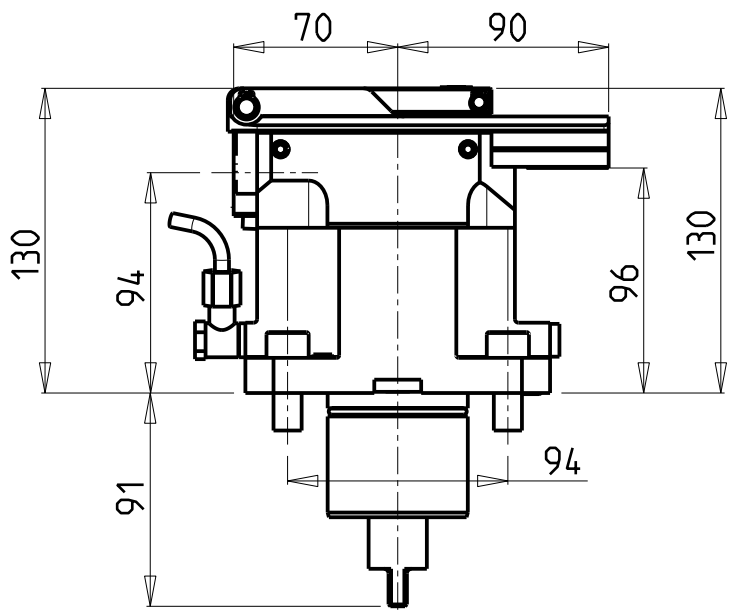

PER UTENSILI STOZZATORI VEDI PAG. TBL400-1-00
 FOR DRIVEN SLOTTING TOOL CUTTING-TOOLS SEE PAGE TBL400-1-00
 FÜR NUTENSTOSS-WERKZEUG SCHNEIDWERKZEUGE SIEHE SEITE TBL400-1-00

Cod. MT	I	RPM MAX	Reversibile lato mandrino/contromandrino Reversible sub/main spindle side Umkehrbare Spindelseite/ Gegenspindelseite	Lubr. esterna Ext. coolant Aussenkuehlung
MNL0650100	4:1	2000	X	X

TAKISAWA
 MOD: TS3000/4000/5000 Y/YS 12 ST. (3 KEYS TURRET)
 MODULO MOTORIZZATO STOZZATORE CORSA 50mm H=94mm
 Slotting driven tool 50mm stroke H=94mm
 Keilnutenstossmaschine 50mm Hub H=94mm

M.T. srl
 Via Casino Albini 480
 Tel. 0541/956034-957884
 Fax 0541/956341
 47842 S. GIOVANNI IN M. (RN)
 e-mail: mtma@mtmarchetti.com
 http://www.mtmarchetti.com

PRODUZIONE MODULI ROTANTI



PAGINA TKW 360-7-00

Subject to change without notice.

10/2018

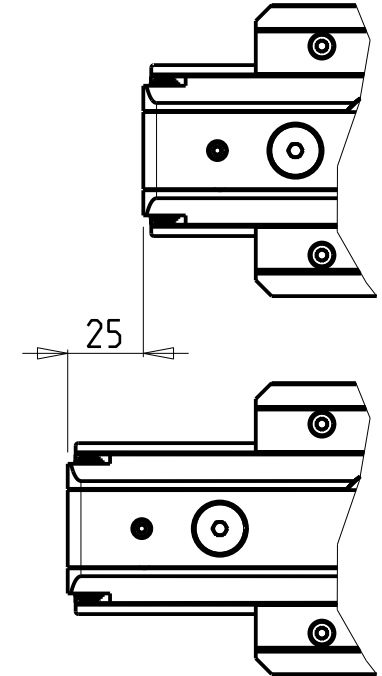
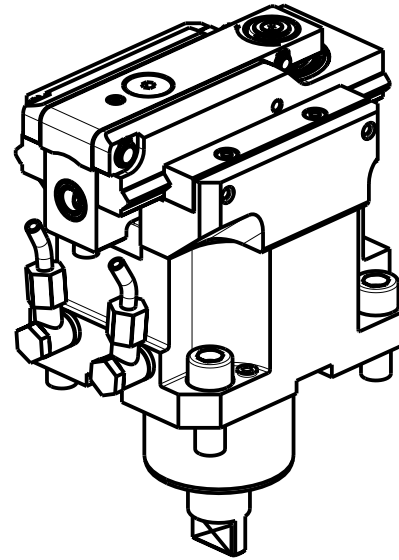
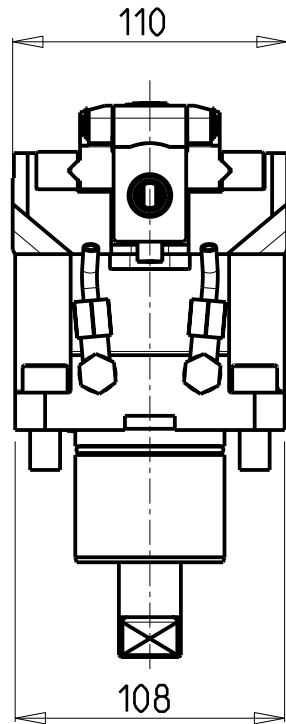
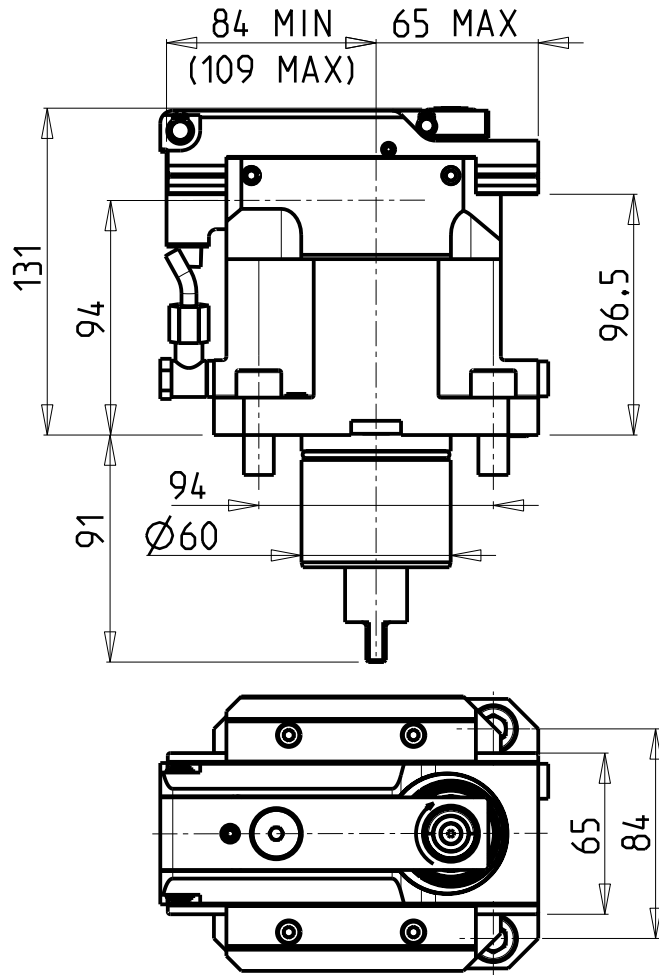

PER UTENSILI STOZZATORI VEDI PAG. TBL400-1-00
 FOR DRIVEN SLOTTING TOOL CUTTING-TOOLS SEE PAGE TBL400-1-00
 FÜR NUTENSTOSS-WERKZEUG SCHNEIDWERKZEUGE SIEHE SEITE TBL400-1-00

Cod. MT	I	RPM MAX	Reversibile lato mandrino/contromandrino Reversible sub/main spindle side Umkehrbare Spindelseite/ Gegenspindelseite	Lubr. esterna Ext. coolant Aussenkuehlung
MNL0650200	4:1	2400	X	X

TAKISAWA
 MOD: TS3000/4000/5000 Y/YS 12 ST. (3 KEYS TURRET)
 MODULO MOTORIZZATO STOZZATORE CORSA 25mm H=94mm
 Slotting driven tool 25mm stroke H=94mm
 Keilnutenstossmaschine 25mm Hub H=94mm

M.T. srl
 Via Casino Albini 480
 Tel. 0541/956034-957884
 Fax 0541/956341
 47842 S. GIOVANNI IN M. (RN)
 e-mail: mtma@mtmarchetti.com
 http://www.mtmarchetti.com

PRODUZIONE MODULI ROTANTI

 PAGINA TKW 360-7-01

Subject to change without notice.

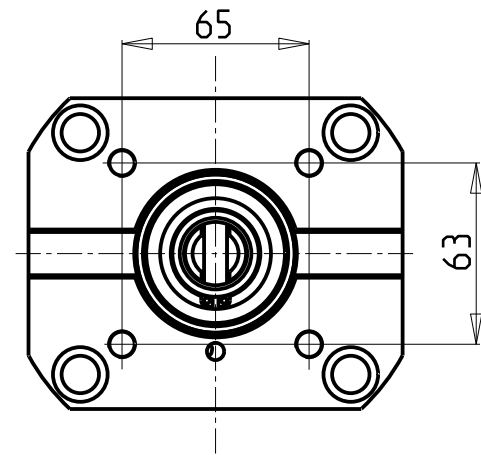
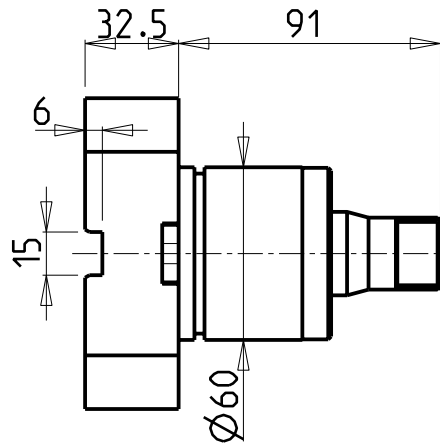
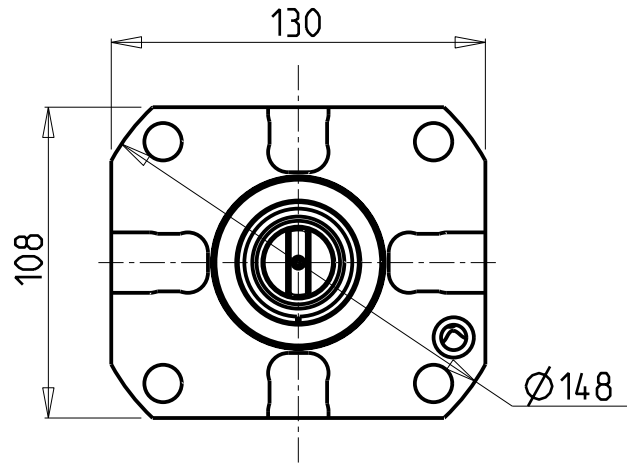
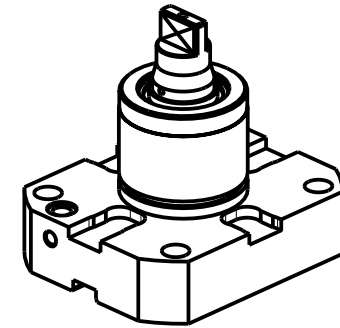
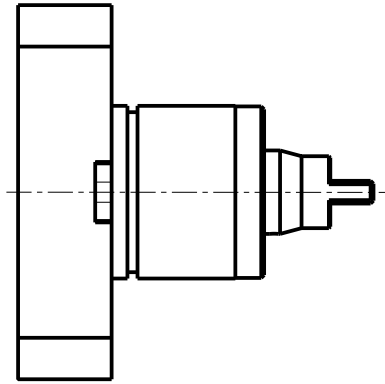
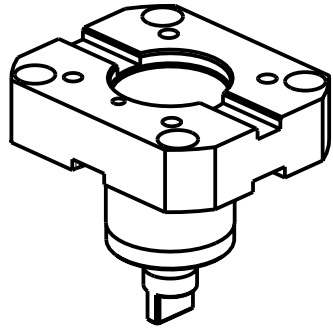
10/2018



Cod. MT

MNL0246055

TAKISAWA

MOD: TS3000/4000/5000 Y/YS 12 ST. (3 KEYS TURRET)

INTERFACCIA PER MODULI BIGLIA

Biglia tooling adapter cartridge

Adapter-Patrone fuer Biglia Werkzeuge

Subject to change without notice.

M.T. srl

Via Casino Albini 480
Tel. 0541/956034-957884
Fax 0541/956341
47842 S. GIOVANNI IN M. (RN)
e-mail: mtma@mtmarchetti.com
<http://www.mtmarchetti.com>

PRODUZIONE MODULI ROTANTI



PAGINA TKW 380-7-00

10/2018

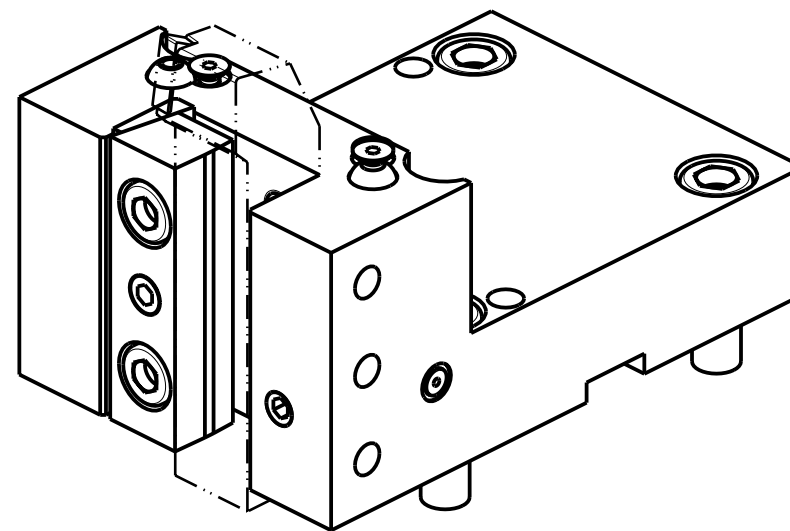
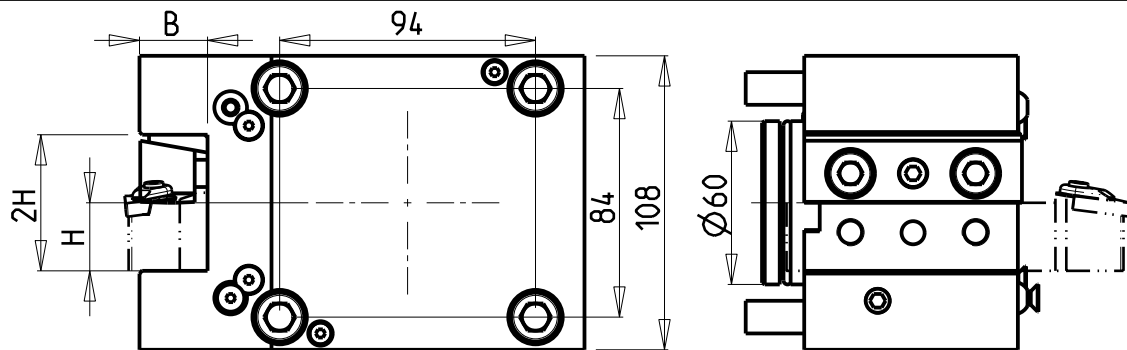

Cod. MT	N°Utensili N°Tools N°Werkzeuge	Reversibile lato mandrino/contromandrino Reversible sub/main spindle side Umkehrbare Spindel-seite/ Gegenspindel-seite	Misure Dimensions Masse	B	H
MNL0042500	1/2	X	mm	25	25
MNL0042540	1/2	X	Inch	1"	1"
MNL0042000	1/2	X	mm	20	20
MNL0041905	1/2	X	Inch	3/4"	3/4"

TAKISAWA

MOD: TS3000/4000/5000 Y/YS 12 ST. (3 KEYS TURRET)

PORTAUTENSILE RADIALE SINGOLO QD=25mm / QD=1" / QD=20mm / QD=3/4"

Radial single static tool QD=25mm / QD=1" / QD=20mm / QD=3/4"

Radial Single-Werkzeughalter QD=25mm / QD=1" / QD=20mm / QD=3/4"

Subject to change without notice.

M.T. srl

Via Casino Albini 480
Tel. 0541/956034-957884
Fax 0541/956341

47842 S. GIOVANNI IN M. (RN)
e-mail: mtma@tmarchetti.com
http://www.tmmarchetti.com

PRODUZIONE MODULI ROTANTI



PAGINA TKW 423-7-00

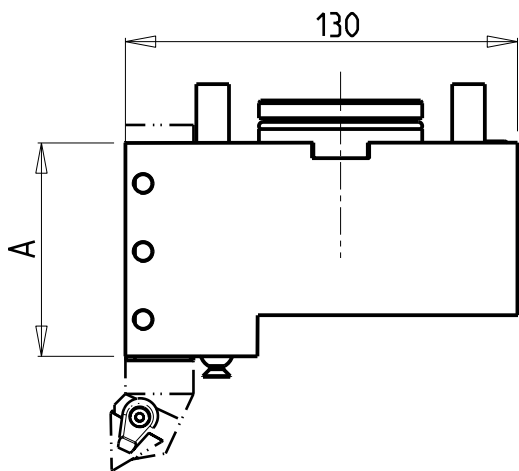
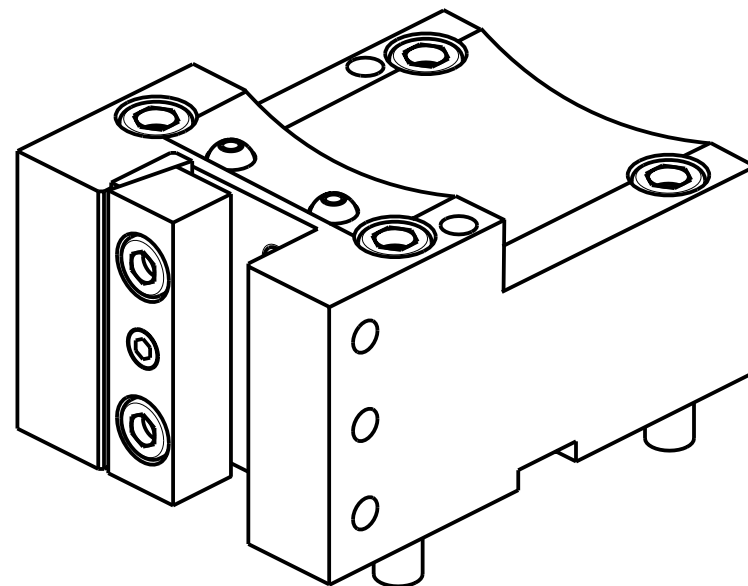
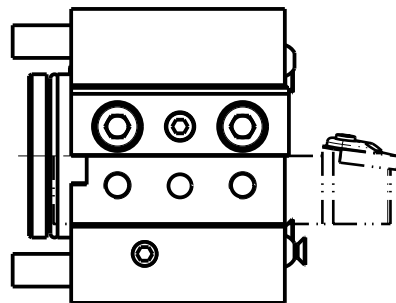
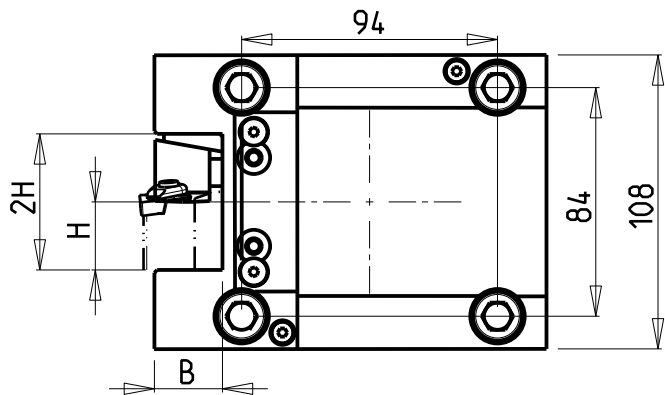

Cod. MT	Cod. MORI-SEIKI	N°Utensili N°Tools N°Werkzeuge	Reversibile lato mandrino/contromandrino Reversible sub/main spindle side Umkehrbare Spindel-seite/ Gegenspindel-seite	Misure Dimensions Masse	A	B	H
MNL0042500_CH	T00186	1/2	X	mm	70	25	25
MNL0042000_CH	T00187	1/2	X	mm	65	20	20

TAKISAWA

MOD: TS3000/4000/5000 Y/YS 12 ST. (3 KEYS TURRET)

PORTAUTENSILE RADIALE SINGOLO QD=25mm / QD=20mm

Radial single static tool QD=25mm / QD=20mm

Radial Single-Werkzeughalter QD=25mm / QD=20mm

Subject to change without notice.

M.T. srl

Via Casino Albini 480
Tel. 0541/956034-957884
Fax 0541/956341

47842 S. GIOVANNI IN M. (RN)
e-mail: mtma@mtmarchetti.com
<http://www.mtmarchetti.com>

PRODUZIONE MODULI ROTANTI



PAGINA TKW 424-7-00

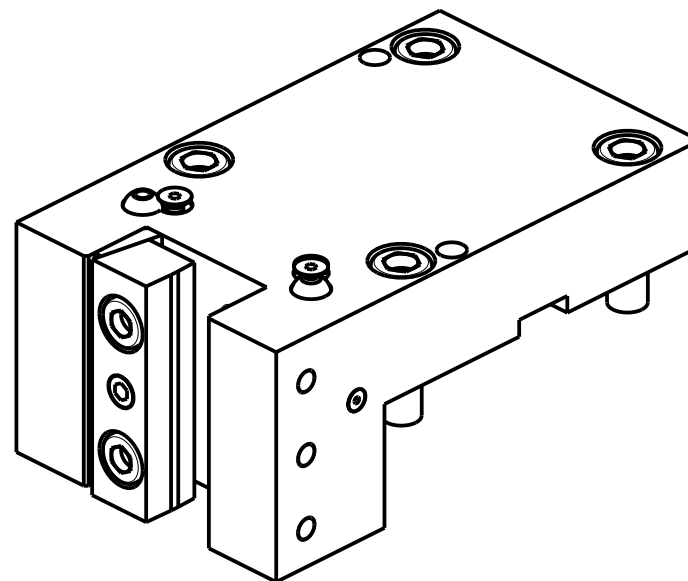
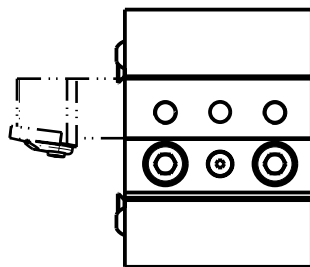
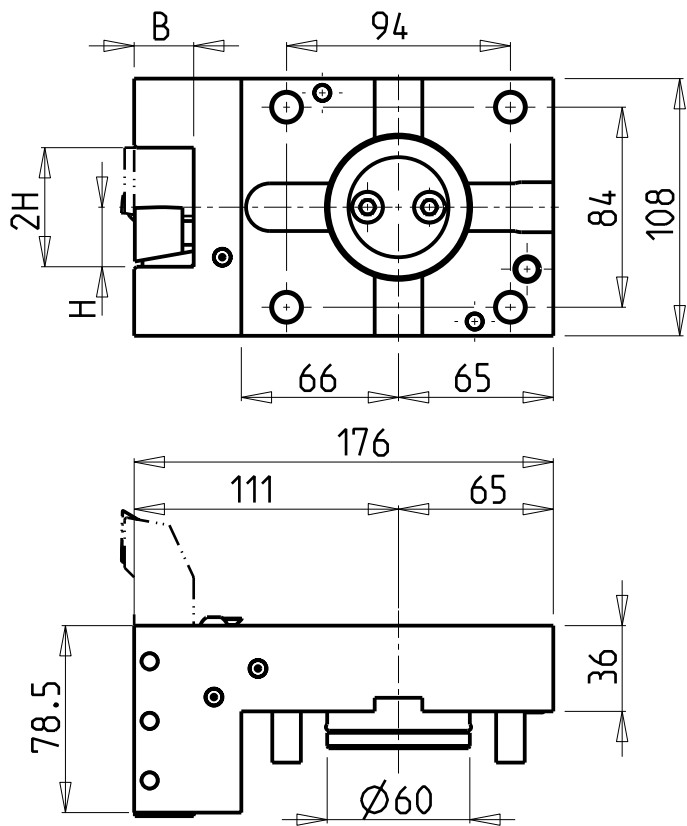

Cod. MT	N°Utensili N° Tools N° Werkzeuge	Misure Dimensions Masse	B	H
MNL0382500	1/2	mm	25	25
MNL0382540	1/2	Inch	1"	1"
MNL0382000	1/2	mm	20	20
MNL0381905	1/2	Inch	3/4"	3/4"

TAKISAWA

MOD: TS3000/4000/5000 Y/YS 12 ST. (3 KEYS TURRET)

PORTAUTENSILE RADIALE SINGOLO ARRETRATO QD=25mm / QD=1" / QD=20mm / QD=3/4"

Radial rear-set single static tool QD=25mm / QD=1" / QD=20mm / QD=3/4"

Radial Single-Werkzeughalter zurueckversetzt QD=25mm / QD=1" / QD=20mm / QD=3/4"

Subject to change without notice.

M.T. srl

Via Casino Albini 480
Tel. 0541/956034-957884
Fax 0541/956341

47842 S. GIOVANNI IN M. (RN)
e-mail: mtma@mtmarchetti.com
http://www.mtmarchetti.com

PRODUZIONE MODULI ROTANTI



PAGINA TKW 433-7-00

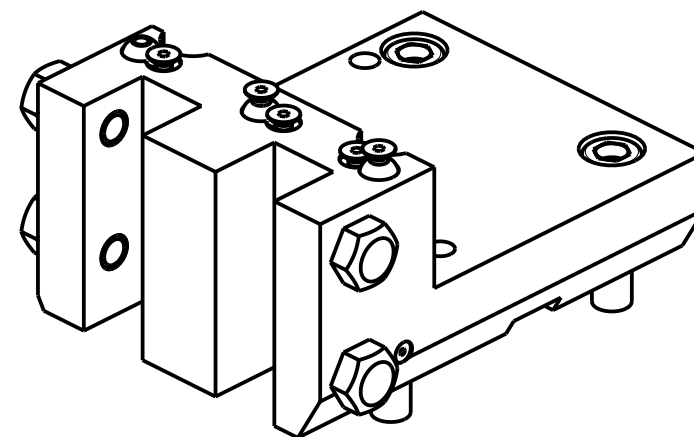
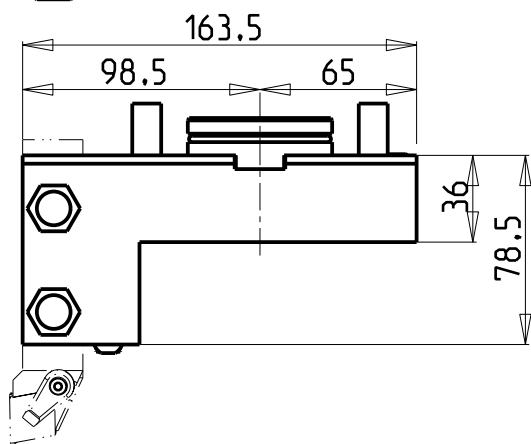
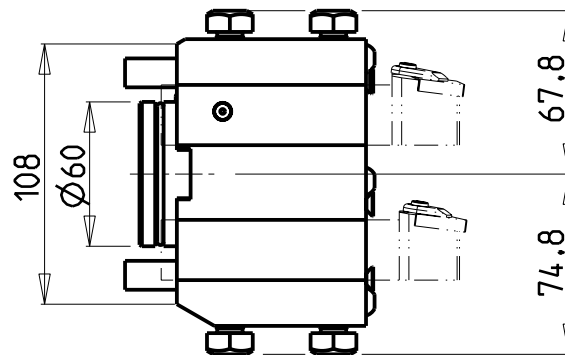
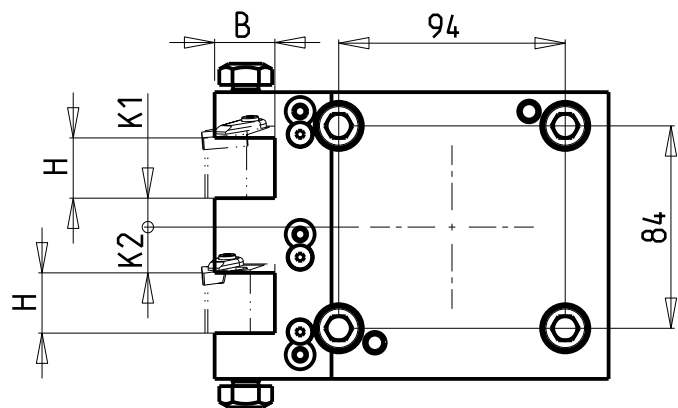

Cod. MT	N°Utensili N°Tools N°Werkzeuge	Reversibile lato mandrino/contromandrino Reversible sub/main spindle side Umkehrbare Spindelseite/ Gegenspindelseite	Misure Dimensions Masse	H	B	K1	K2
MNL0062500	2	X	mm	25	25	12	19
MNL0062540	2	X	Inch	1"	1"	1/2"	3/4"
MNL0062000	2	X	mm	20	20	12	19
MNL0061905	2	X	Inch	3/4"	3/4"	1/2"	3/4"

TAKISAWA
 MOD: TS3000/4000/5000 Y/YS 12 ST. (3 KEYS TURRET)

PORTAUTENSILE RADIALE SOVRAPPOSTO QD=25mm / QD=1" / QD=20mm / QD=3/4"
 Radial single side twin static tool QD=25mm / QD=1" / QD=20mm / QD=3/4"
 Radial Werkzeughalter ueberlagert QD=25mm / QD=1" / QD=20mm / QD=3/4"

Subject to change without notice.

M.T. srl

Via Casino Albini 480
 Tel. 0541/956034-957884
 Fax 0541/956341
 47842 S. GIOVANNI IN M. (RN)
 e-mail: mtma@tmarchetti.com
 http://www.tmmarchetti.com

PRODUZIONE MODULI ROTANTI



PAGINA TKW 442-7-00

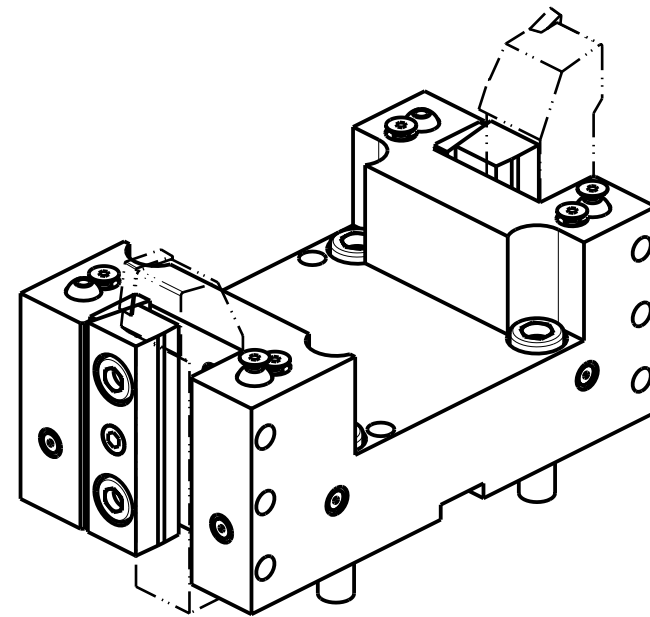
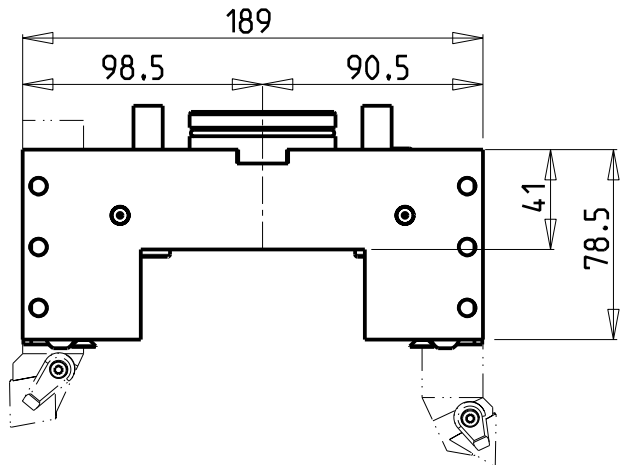
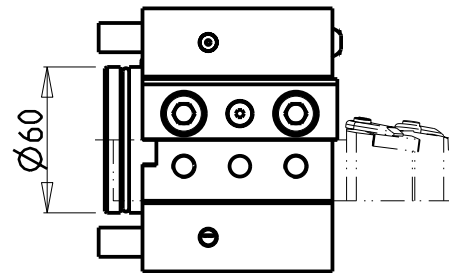
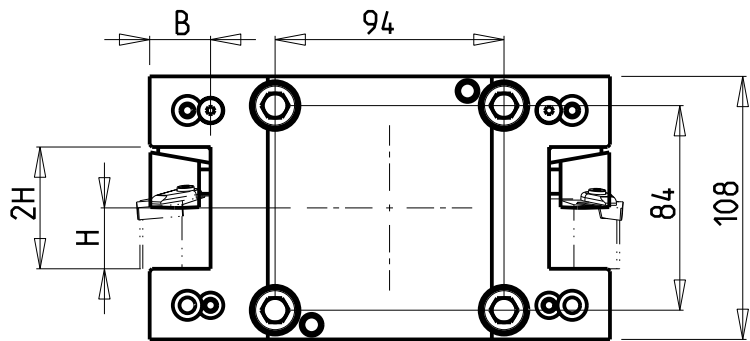

Cod. MT	Cod. MORI-SEIKI	N°Utensili N°Tools N°Werkzeuge	Reversibile lato mandrino/contromandrino Reversible sub/main spindle side Umkehrbare Spindel-seite/ Gegenspindel-seite	Misure Dimensions Masse	B	H
MNL0052500	T00184	2/4	X	mm	25	25
MNL0052540	T00199	2/4	X	Inch	1"	1"
MNL0052000	T00185	2/4	X	mm	20	20
MNL0051905	T00201	2/4	X	Inch	3/4"	3/4"

TAKISAWA

MOD: TS3000/4000/5000 Y/YS 12 ST. (3 KEYS TURRET)

PORTAUTENSILE RADIALE DOPPIO QD=25mm / QD=1" / QD=20mm / QD=3/4"

Radial double static tool QD=25mm / QD=1" / QD=20mm / QD=3/4"

Radial Doppel-Werkzeughalter QD=25mm / QD=1" / QD=20mm / QD=3/4"

Subject to change without notice.

M.T. srl

Via Casino Albini 480
Tel. 0541/956034-957884
Fax 0541/956341

47842 S. GIOVANNI IN M. (RN)
e-mail: mtma@tmarchetti.com
http://www.tmmarchetti.com

PRODUZIONE MODULI ROTANTI



PAGINA TKW453-7-00

10/2018

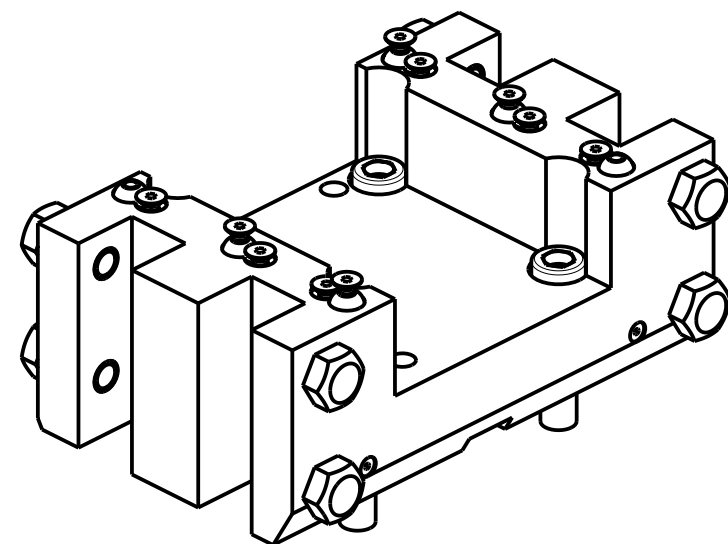
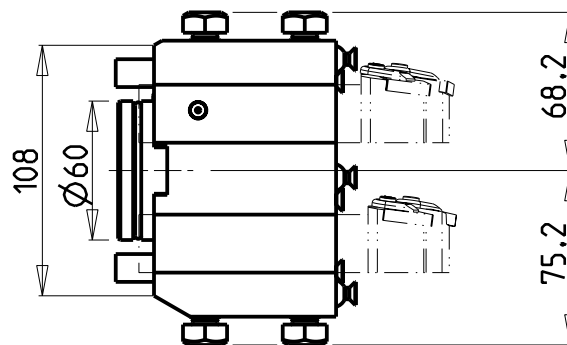
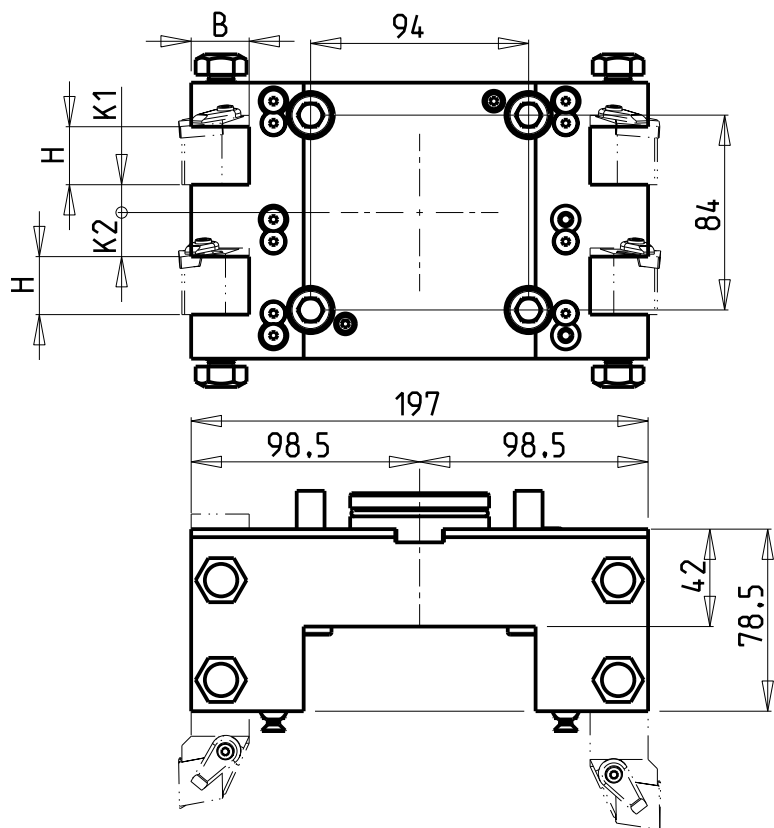

Cod. MT	N°Utensili N°Tools N°Werkzeuge	Reversibile lato mandrino/contromandrino Reversible sub/main spindle side Umkehrbare Spindelseite/ Gegenspindelseite	Misure Dimensions Masse	H	B	K1	K2
MNL0072500	4	X	mm	25	25	12	19
MNL0072540	4	X	Inch	1"	1"	1/2"	3/4"
MNL0072000	4	X	mm	20	20	12	19
MNL0071905	4	X	Inch	3/4"	3/4"	1/2"	3/4"

TAKISAWA

MOD: TS3000/4000/5000 Y/YS 12 ST. (3 KEYS TURRET)

PORTAUTENSILE RADIALE DOPPIO SOVRAPPONTO QD=25mm / QD=1" / QD=20mm / QD=3/4"

Radial double side twin static tool QD=25mm / QD=1" / QD=20mm / QD=3/4"

Radial Doppel-Werkzeughalter ueberlagert QD=25mm / QD=1" / QD=20mm / QD=3/4"

Subject to change without notice.

M.T. srl

Via Casino Albini 480
Tel. 0541/956034-957884
Fax 0541/956341

47842 S. GIOVANNI IN M. (RN)
e-mail: mtma@tmarchetti.com
http://www.tmmarchetti.com

PRODUZIONE MODULI ROTANTI



PAGINA TKW463-7-00

10/2018

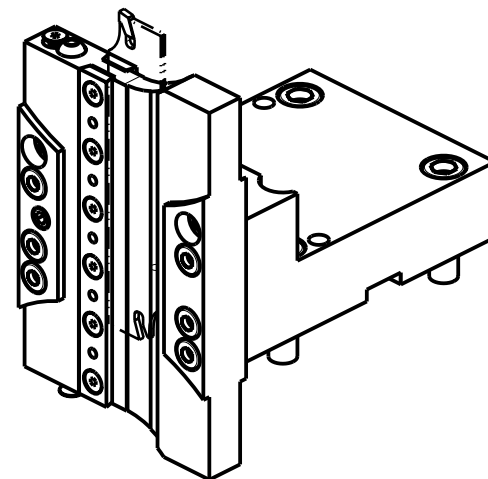
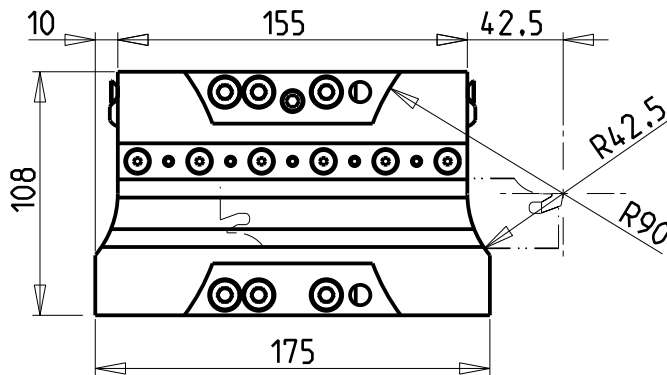
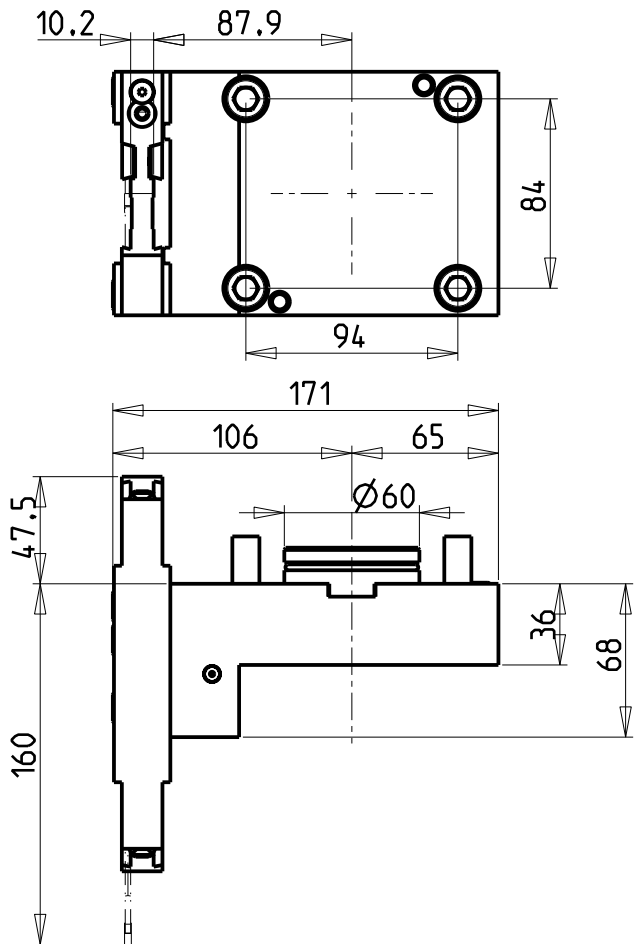

POSSIBILITA' DI LAVORO M3/M4
 OPTION OF M3/M4 WORKING
 ARBEITSMÖGLICHKEIT M3/M4

DOTAZIONI - SUPPLIED WITH - AUSSTATTUNG

- N°1 - LAMA - BLADE - KLINGE ISCAR H=32 Sp. 3/4mm (KENNAMETAL OPTIONAL)
- N°10 - INSERTI - INSERTS - EINLAGEN
- N°1 - CHIAVE A T PER MONTAGGIO INSERTI
 - T-WRENCH FOR INSERT SET UP
 - T-SCHLUESSEL FUER EINSATZSTUECK-MONTAGE

Cod. MT N°Utensili
 N°Tools
 N°Werkzeuge

MNL0140132 1

TAKISAWA
 MOD: TS3000/4000/5000 Y/YS 12 ST. (3 KEYS TURRET)

PORTAUTENSILE PER LAMA DOPPIO
 Radial double blade holder
 Radial Doppel-Abstechhalter

Subject to change without notice.

M.T. srl

Via Casino Albini 480
 Tel. 0541/956034-957884
 Fax 0541/956341
 47842 S. GIOVANNI IN M. (RN)
 e-mail: mtma@mtmarchetti.com
 http://www.mtmarchetti.com

PRODUZIONE MODULI ROTANTI



PAGINA TKW520-7-00

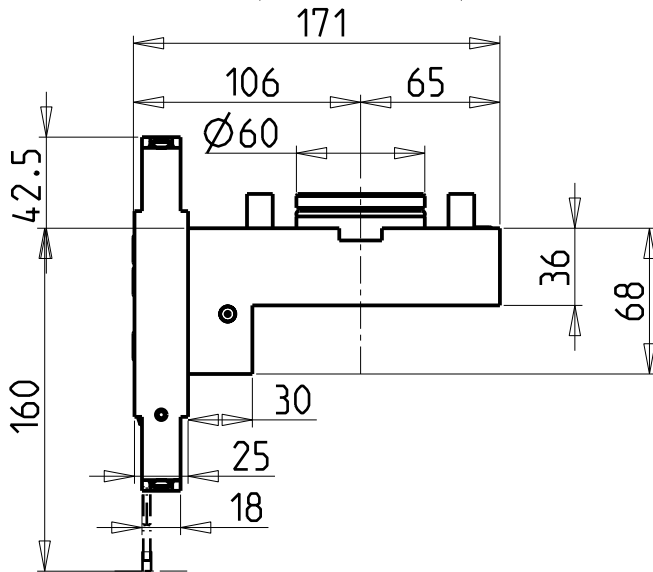
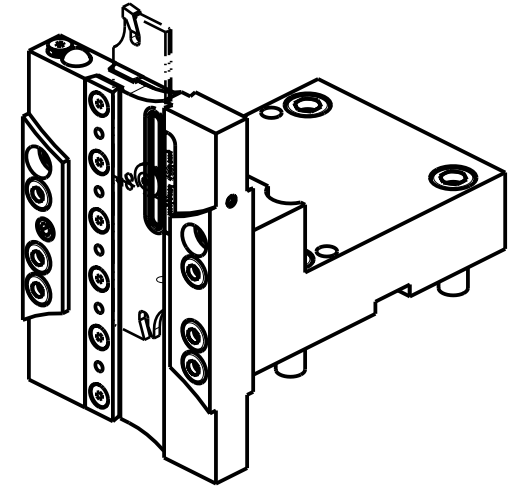
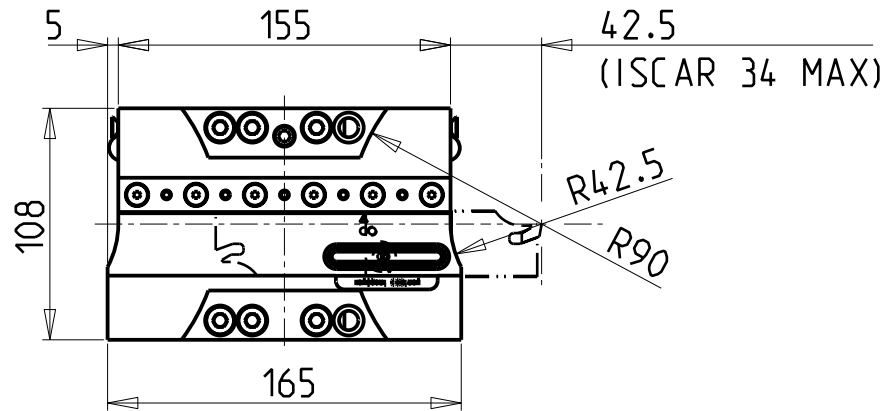
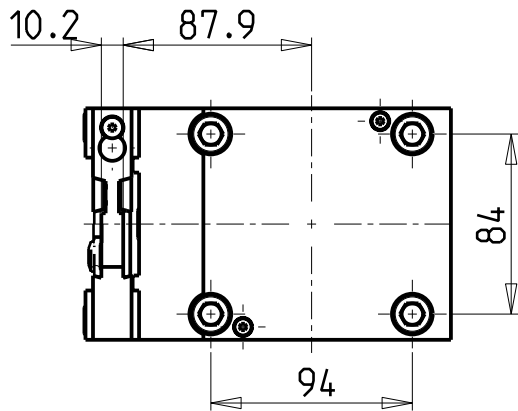

POSSIBILITA' DI LAVORO M3/M4
 OPTION OF M3/M4 WORKING
 ARBEITSMÖGLICHKEIT M3/M4

**KIT LAME NON INCLUSI (OPZIONALI)
 BLADES NOT SUPPLIED WITH (OPTIONAL)
 KLINGEN NICHT INBEGRIFFEN (OPTIONAL)**

- LAMA-BLADE-KLINGE SANDVIK H=32 sp.3 cod. QD_NN2G60C25A
 +INSERTI-INSERTS-EINLAGEN cod. QD_NG_0300_0002_CM_1145 (10 pz.)
- LAMA-BLADE-KLINGE SANDVIK H=32 sp.4 cod. QD_NN2H60C25A
 +INSERTI-INSERTS-EINLAGEN cod. QD_NH_0400_0002_CM_1145 (10 pz.)
- LAMA-BLADE-KLINGE ISCAR H=32 sp.3 cod. SGFH_32K_3
 +INSERTI-INSERTS-EINLAGEN cod. 6011365 (10pz.)
- LAMA-BLADE-KLINGE ISCAR H=32 sp.4 cod. SGFH_32K_4
 +INSERTI-INSERTS-EINLAGEN cod. 6011366 (10pz.)
- LAMA-BLADE-KLINGE WALTER H=32 sp.3 cod. G2042.32N-3T45SX-P
 +INSERTI-INSERTS-EINLAGEN cod. SX-3E300N02-CE4 WSM33S (10pz.) + CHIAVE-KEY cod. FS1494
- LAMA-BLADE-KLINGE WALTER H=32 sp.4 cod. G2042.32N-4T50SX-P
 +INSERTI-INSERTS-EINLAGEN cod. SX-4E400N02-CE4 WSM33S (10pz.) + CHIAVE-KEY cod. FS1494

Cod. MT	N°Utensili N°Tools N°Werkzeuge	Lubr.esterna Ext. coolant Aussenkuehlung	Lubr.interna Coolant through Innenkuehlung
MNL0860132	1	X	P=70bar

TAKISAWA
 MOD: TS3000/4000/5000 Y/YS 12 ST. (3 KEYS TURRET)

PORTAUTENSILE PER LAMA DOPPIO CON LUBRIFICAZIONE INTERNA
 Radial double blade holder with internal coolant
 Radial Doppel-Abstechhalter mit Innenkuehlung

Subject to change without notice.

M.T. srl
 Via Casino Albini 480
 Tel. 0541/956034-957884
 Fax 0541/956341
 47842 S. GIOVANNI IN M. (RN)
 e-mail: mtma@mtmarchetti.com
 http://www.mtmarchetti.com

PRODUZIONE MODULI ROTANTI



PAGINA TKW520-7-04

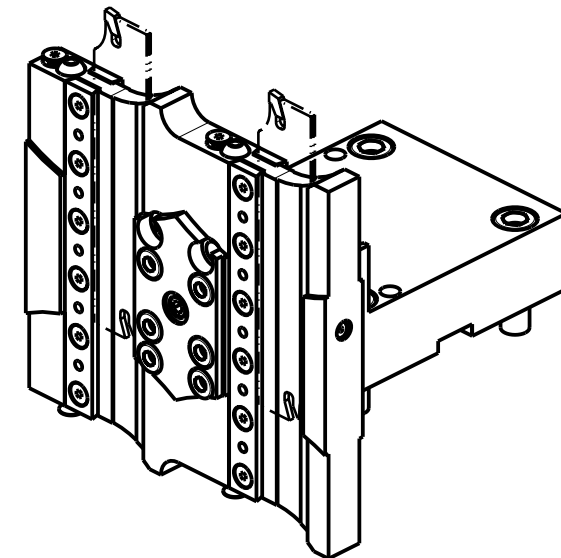
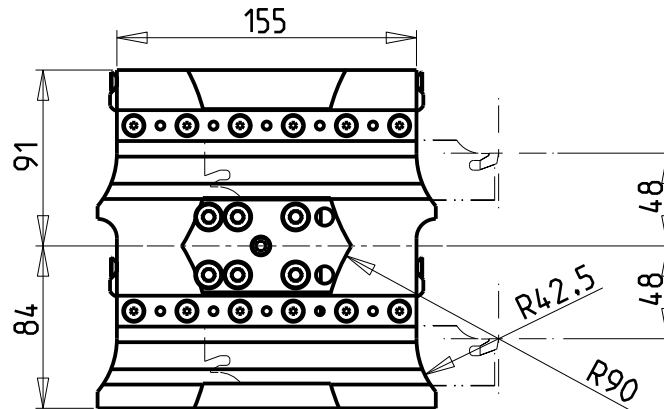
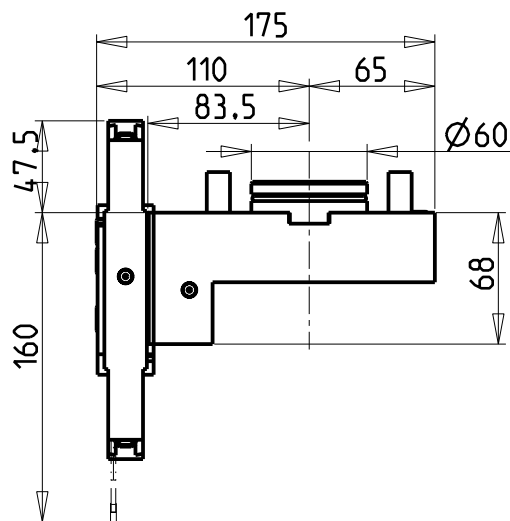
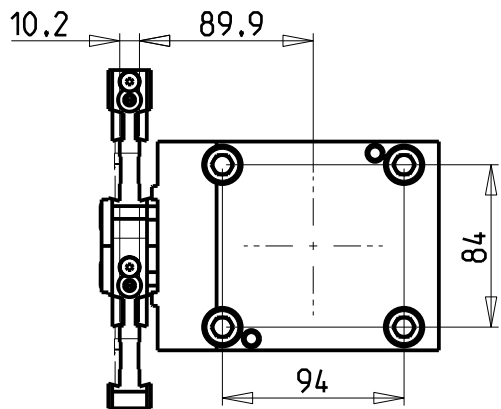

POSSIBILITA' DI LAVORO M3/M4
 OPTION OF M3/M4 WORKING
 ARBEITSMOGLICHKEIT M3/M4

SOLO PER MACCHINE CON ASSE Y
 ONLY FOR Y-AXIS MACHINES
 NUR FUR MASCHINEN MIT ACHSE Y

DOTAZIONI - SUPPLIED WITH - AUSSTATTUNG

N°1 - LAMA - BLADE - KLINGE ISCAR H=32 Sp. 3/4mm
 (KENNAMETAL OPTIONAL)

N°10 - INSERTI - INSERTS - EINLAGEN

N°1 - CHIAVE A T PER MONTAGGIO INSERTI
 - T-WRENCH FOR INSERT SET UP
 - T-SCHLUESSEL FUER EINSATZSTUECK-MONTAGE

Cod. MT

N°Utensili
 N° Tools
 N° Werkzeuge

MNL0160232

2

TAKISAWA

MOD: TS3000/4000/5000 Y/YS 12 ST. (3 KEYS TURRET)

PORTAUTENSILE PER LAMA DOPPIO SOVRAPPOSTO

Radial double twin-side blade holder

Radial Doppel-Abstechhalter ueberlagert

Subject to change without notice.

M.T. srl

Via Casino Albini 480
 Tel. 0541/956034-957884
 Fax 0541/956341
 47842 S. GIOVANNI IN M. (RN)
 e-mail: mtma@mtmarchetti.com
 http://www.mtmarchetti.com

PRODUZIONE MODULI ROTANTI



PAGINA TKW525-7-00

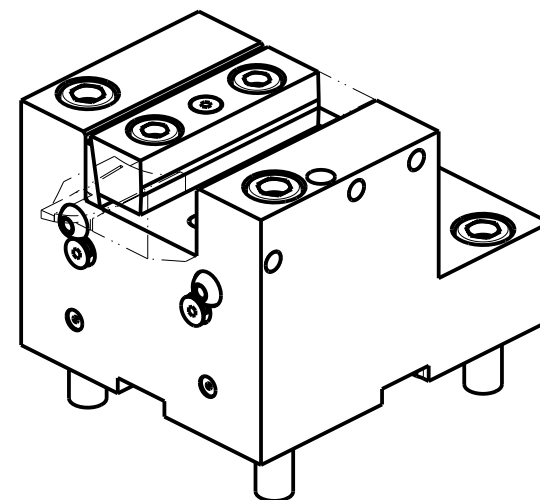
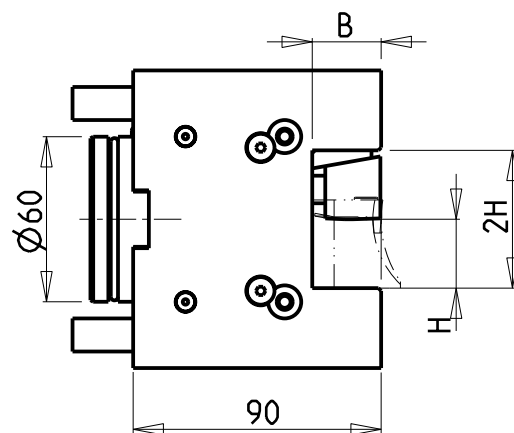
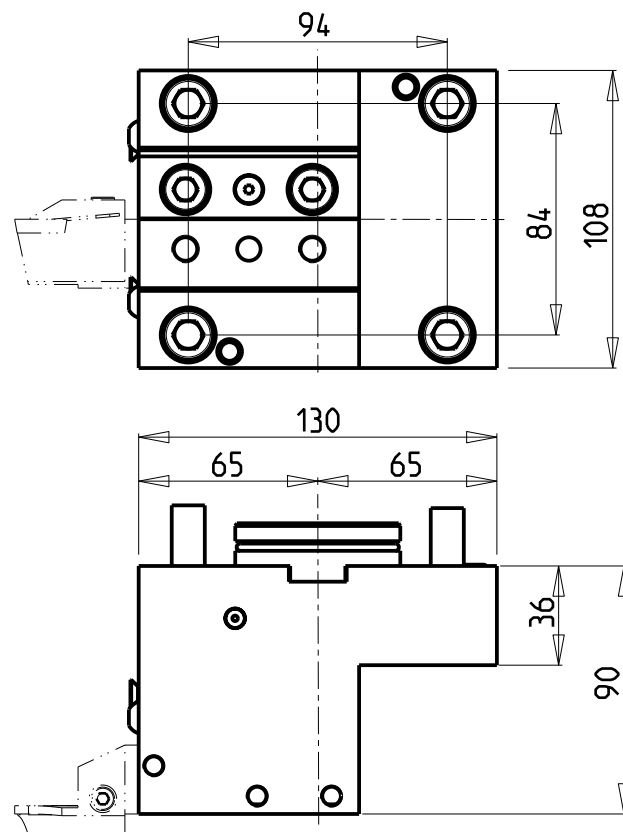

Cod. MT	N°Utensili N°Tools N°Werkzeuge	Reversibile lato mandrino/contromandrino Reversible sub/main spindle side Umkehrbare Spindel-seite/ Gegenspindel-seite	Misure Dimensions Masse	B	H
MNL0132500	1/2	X	mm	25	25
MNL0132540	1/2	X	Inch	1"	1"
MNL0132000	1/2	X	mm	20	20
MNL0131905	1/2	X	Inch	3/4"	3/4"

TAKISAWA

MOD: TS3000/4000/5000 Y/YS 12 ST. (3 KEYS TURRET)

PORTAUTENSILE ASSIALE SINGOLO QD=25mm / QD=1" / QD=20mm / QD=3/4"

Single axial static tool QD=25mm / QD=1" / QD=20mm / QD=3/4"

Axial Single-Werkzeughalter QD=25mm / QD=1" / QD=20mm / QD=3/4"

Subject to change without notice.

M.T. srl

Via Casino Albini 480
Tel. 0541/956034-957884
Fax 0541/956341

47842 S. GIOVANNI IN M. (RN)
e-mail: mtma@mtmarchetti.com
http://www.mtmarchetti.com

PRODUZIONE MODULI ROTANTI



PAGINA TKW552-7-00

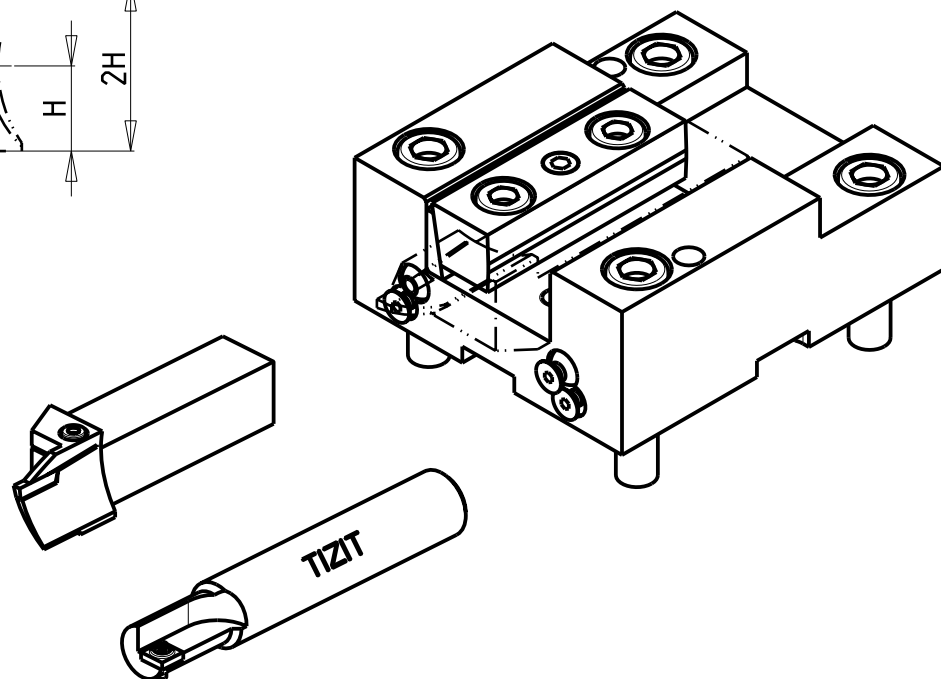
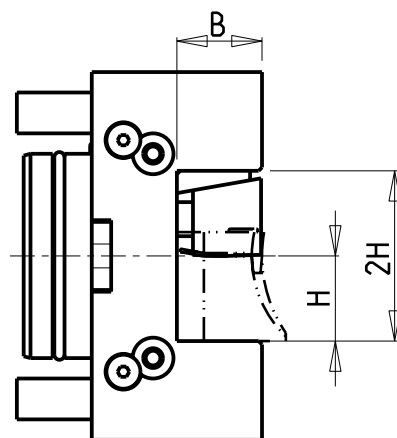
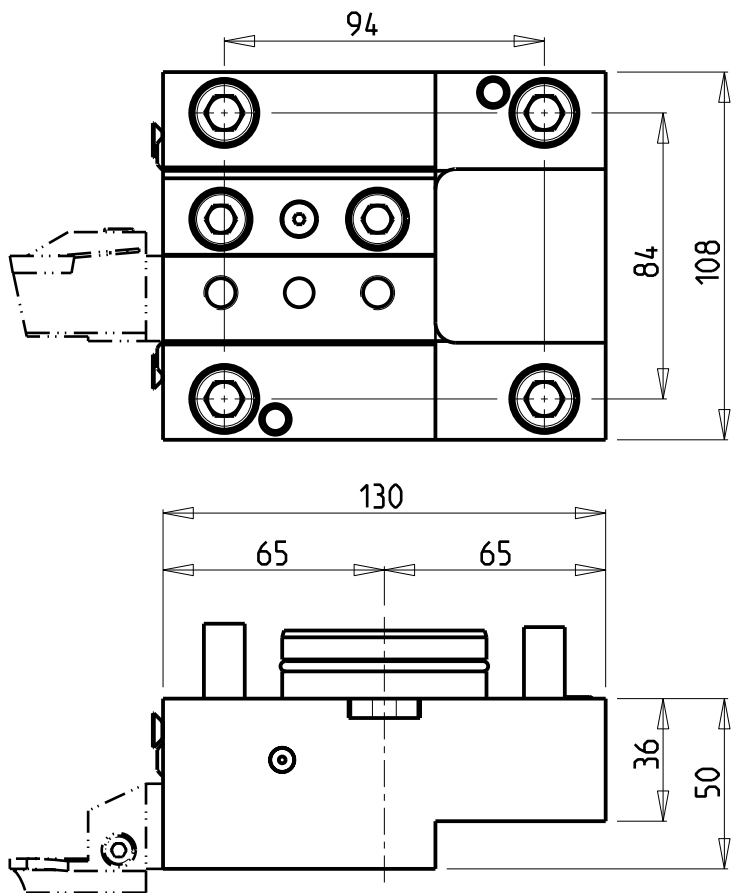

Cod. MT	N°Utensili N° Tools N° Werkzeuge	Reversibile lato mandrino/contromandrino Reversible sub/main spindle side Umkehrbare Spindel-seite/ Gegenspindel-seite	Misure Dimensions Masse	B	H
MNL0302500	1	X	mm	25	25
MNL0302000	1	X	mm	20	20

TAKISAWA

MOD: TS3000/4000/5000 Y/YS 12 ST. (3 KEYS TURRET)

PORTAUTENSILE ASSIALE RIBASSATO SINGOLO QD=25mm / QD=20mm

Axial single lower height static tool QD=25mm / QD=20mm

Axial Single-Werkzeughalter abgeflacht QD=25mm / QD=20mm

Subject to change without notice.

M.T. srl

Via Casino Albini 480
Tel. 0541/956034-957884
Fax 0541/956341

47842 S. GIOVANNI IN M. (RN)
e-mail: mtma@mtmarchetti.com
http://www.mtmarchetti.com

PRODUZIONE MODULI ROTANTI



PAGINA TKW562-7-00

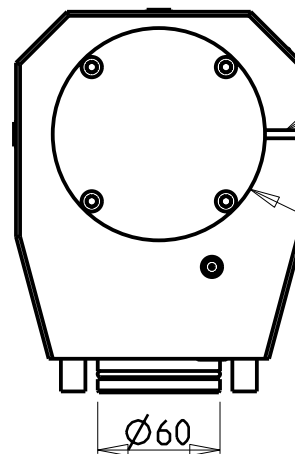
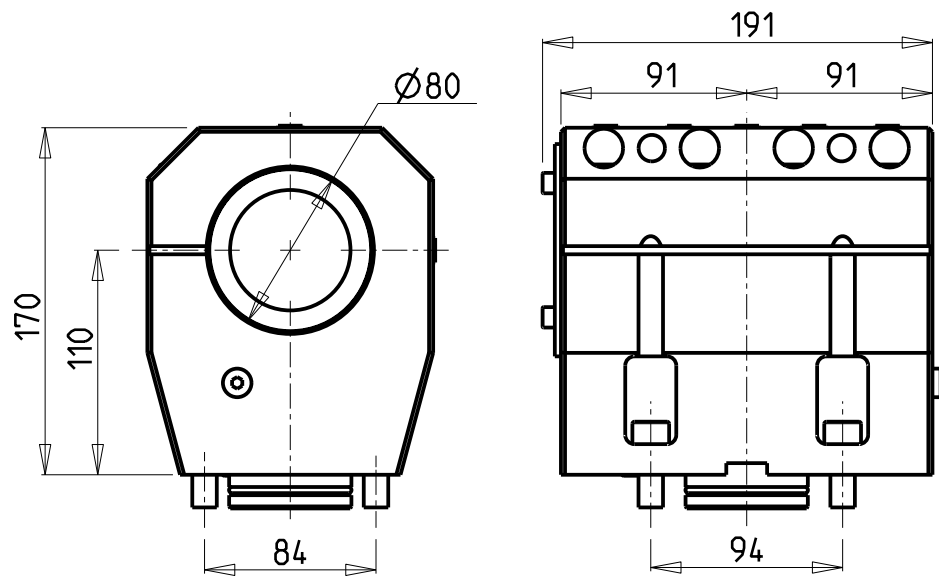

SOLO GUARNIZIONE (OPZIONALE)
 ONLY SEAL (OPTIONAL)
 NUR DICHTUNG (OPTIONAL)
 cod. MNL0620002

KIT ADDUZIONE INTERNA (OPZIONALE)
 KIT FOR INTERNAL COOLANT (OPTIONAL)
 KIT FUER INTERNE KUEHLMITTELZUFUHR (OPTIONAL)
 Ø80 cod. KIT1005013

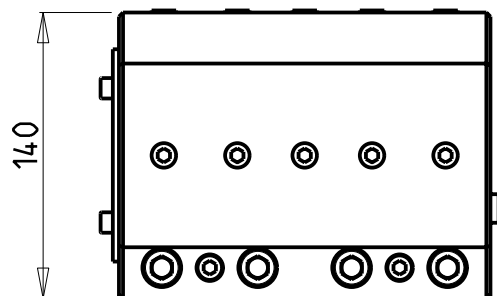

ATTENZIONE - ATTENTION - ACHTUNG

- VERIFICARE LE MISURE DI INGOMBRO PER POSSIBILE INTERFERENZA SU ALCUNI MODELLI DI MACCHINE
- Please check the overall sizes for possible interferences on some machine models
- Bitte überprüfen sie das ausmass um mögliche interferenzen auf einigen maschinen modellen zu vermeiden

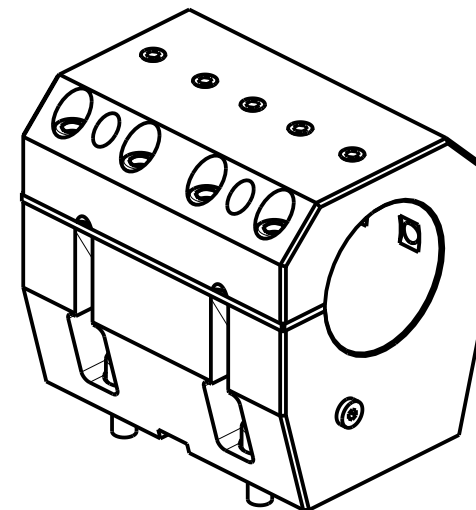

PER BOCCOLE DI RIDUZIONE VEDI PAG. TBL150-1-00
 FOR REDUCING BUSHINGS SEE PAGE TBL150-1-00
 FÜR REDUZIERBUCHSE SIEHE SEITE TBL150-1-00

Cod. MT	N°Utensili N°Tools N°Werkzeuge	Lubrificazione int. opzionale Coolant through optional Innenkühlung Optional	Lubrificazione est. Ext. coolant Aussenkühlung
MNL0628000	1	X	X

TAKISAWA
 MOD: TS3000/4000/5000 Y/YS 12 ST. (3 KEYS TURRET)

PORTAUTENSILE ASSIALE PER BARENO Ø80mm H=110mm
 Axial single boring bar holder Ø80mm H=110mm
 Axial Bohrhälter Ø80mm H=110mm

Subject to change without notice.

M.T. srl

Via Casino Albini 480
 Tel. 0541/956034-957884
 Fax 0541/956341
 47842 S. GIOVANNI IN M. (RN)
 e-mail: mtma@mtmarchetti.com
 http://www.mtmarchetti.com

PRODUZIONE MODULI ROTANTI



PAGINA TKW580-7-20

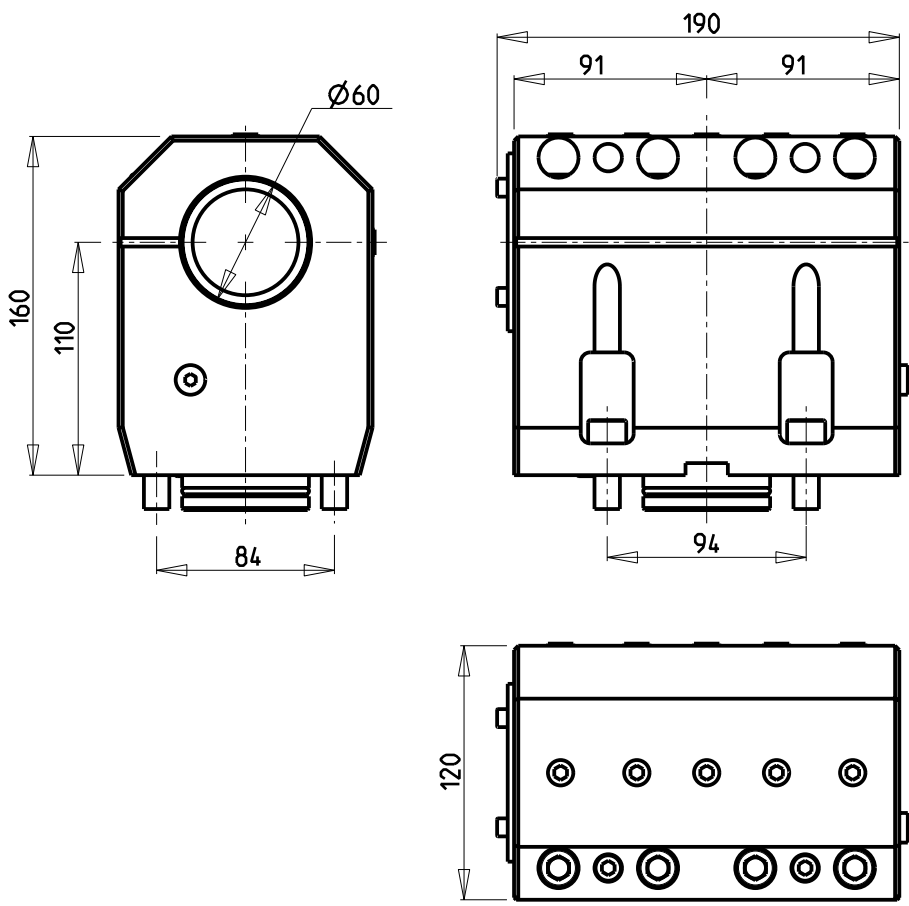

SOLO GUARNIZIONE (OPZIONALE)
 ONLY SEAL (OPTIONAL)
 NUR DICHTUNG (OPTIONAL)
 cod. MNL0620002

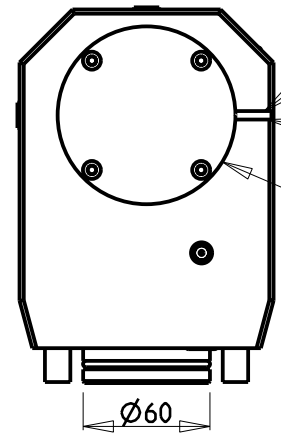

KIT ADDUZIONE INTERNA (OPZIONALE)
 KIT FOR INTERNAL COOLANT (OPTIONAL)
 KIT FUER INTERNE KUEHLMITTELZUFUHR (OPTIONAL)
 Ø60 cod. KIT1005025

ATTENZIONE - ATTENTION - ACHTUNG

- VERIFICARE LE MISURE DI INGOMBRO PER POSSIBILE INTERFERENZA SU ALCUNI MODELLI DI MACCHINE
- Please check the overall sizes for possible interferences on some machine models
- Bitte überprüfen sie das ausmass um mögliche interferenzen auf einigen maschinen modellen zu vermeiden

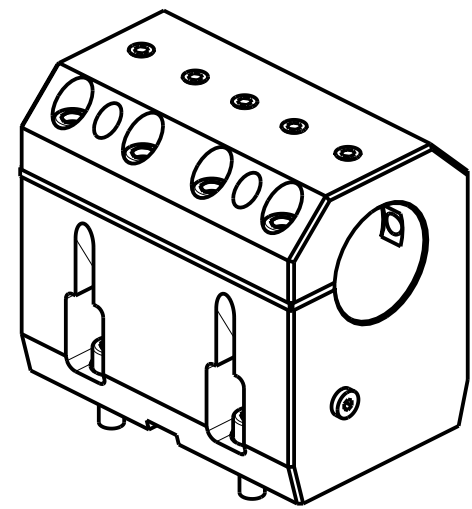

Cod. MT	N°Utensili N°Tools N°Werkzeuge	Lubrificazione int. opzionale Coolant through optional Innenkühlung Optional	Lubrificazione est. Ext. coolant Aussenkühlung
MNL0616000	1	X	X

PER BOCCOLE DI RIDUZIONE VEDI PAG. TBL150-1-00
 FOR REDUCING BUSHINGS SEE PAGE TBL150-1-00
 FÜR REDUZIERBUCHSE SIEHE SEITE TBL150-1-00

TAKISAWA
 MOD: TS3000/4000/5000 Y/YS 12 ST. (3 KEYS TURRET)
 PORTAUTENSILE ASSIALE PER BARENO Ø60mm H=110mm
 Axial single boring bar holder Ø60mm H=110mm
 Axial Bohrhälter Ø60mm H=110mm

M.T. srl
 Via Casino Albini 480
 Tel. 0541/956034-957884
 Fax 0541/956341
 47842 S. GIOVANNI IN M. (RN)
 e-mail: mtma@mtmarchetti.com
 http://www.mtmarchetti.com

PRODUZIONE MODULI ROTANTI

 PAGINA TKW590-7-20

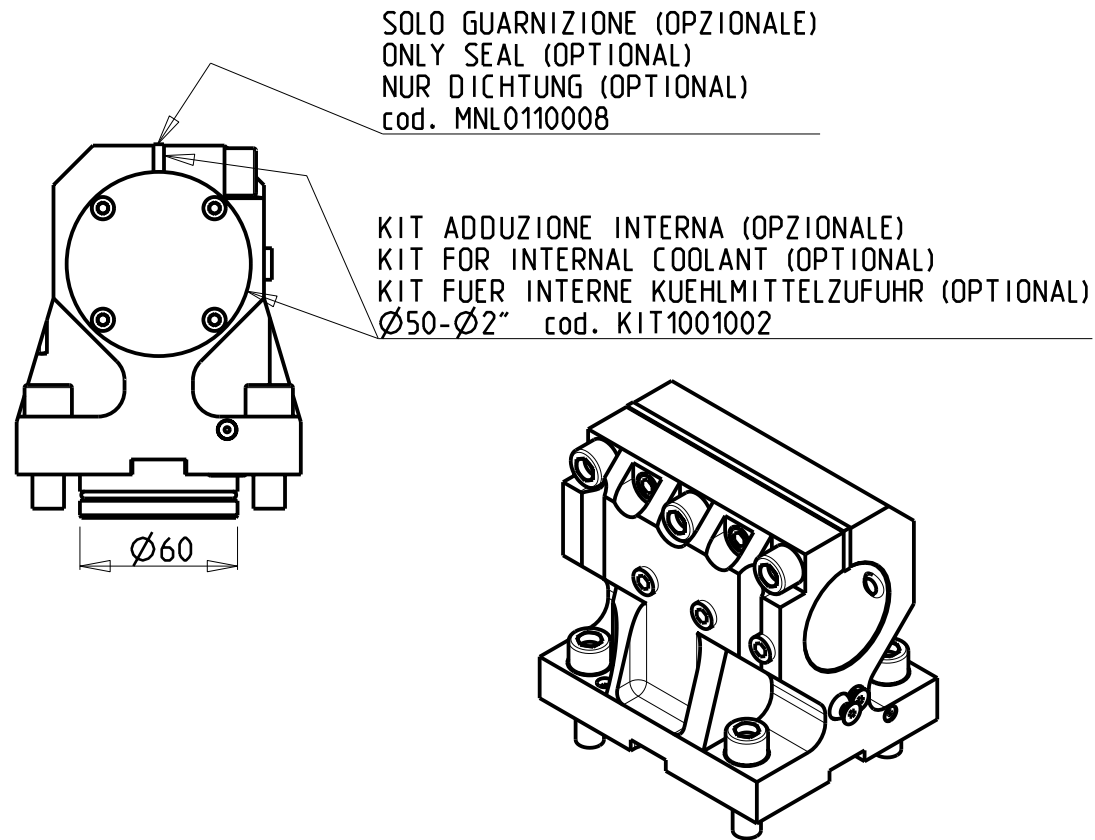
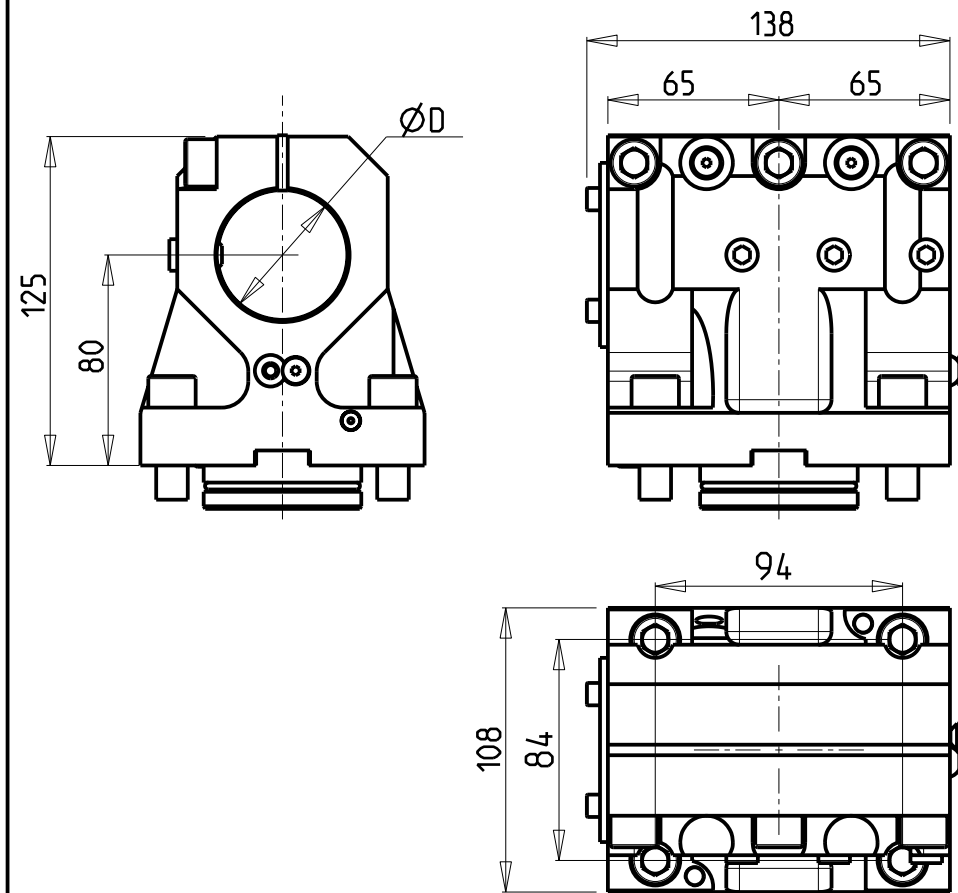
Subject to change without notice.



PER BOCCOLE DI RIDUZIONE VEDI PAG. TBL150-1-00
 FOR REDUCING BUSHINGS SEE PAGE TBL150-1-00
 FÜR REDUZIERBUCHSE SIEHE SEITE TBL150-1-00

Cod. MT	N°Utensili N°Tools N°Werkzeuge	Reversibile lato mandrino/contromandrino Reversible sub/main spindle side Umkehrbare Spindel-seite/ Gegenspindel-seite	Lubrificazione int. opzionale Coolant through optional Innenkühlung Optional	Lubrificazione est. Ext. coolant Aussenkühlung	Misure Dimensions Masse	D
MNL0115000	1	X	X	X	mm	50
MNL0115080	1	X	X	X	Inch	2"

TAKISAWA
 MOD: TS3000/4000/5000 Y/YS 12 ST. (3 KEYS TURRET)
 PORTAUTENSILE ASSIALE PER BARENO Ø50mm / Ø2" H=80mm
 Axial single boring bar holder Ø50mm / Ø2" H=80mm
 Axial Bohrhälter Ø50mm / Ø2" H=80mm

Subject to change without notice.

M.T. srl
 Via Casino Albini 480
 Tel. 0541/956034-957884
 Fax 0541/956341
 47842 S. GIOVANNI IN M. (RN)
 e-mail: mtma@mtmarchetti.com
 http://www.mtmarchetti.com

PRODUZIONE MODULI ROTANTI



PAGINA TKW 610-7-20

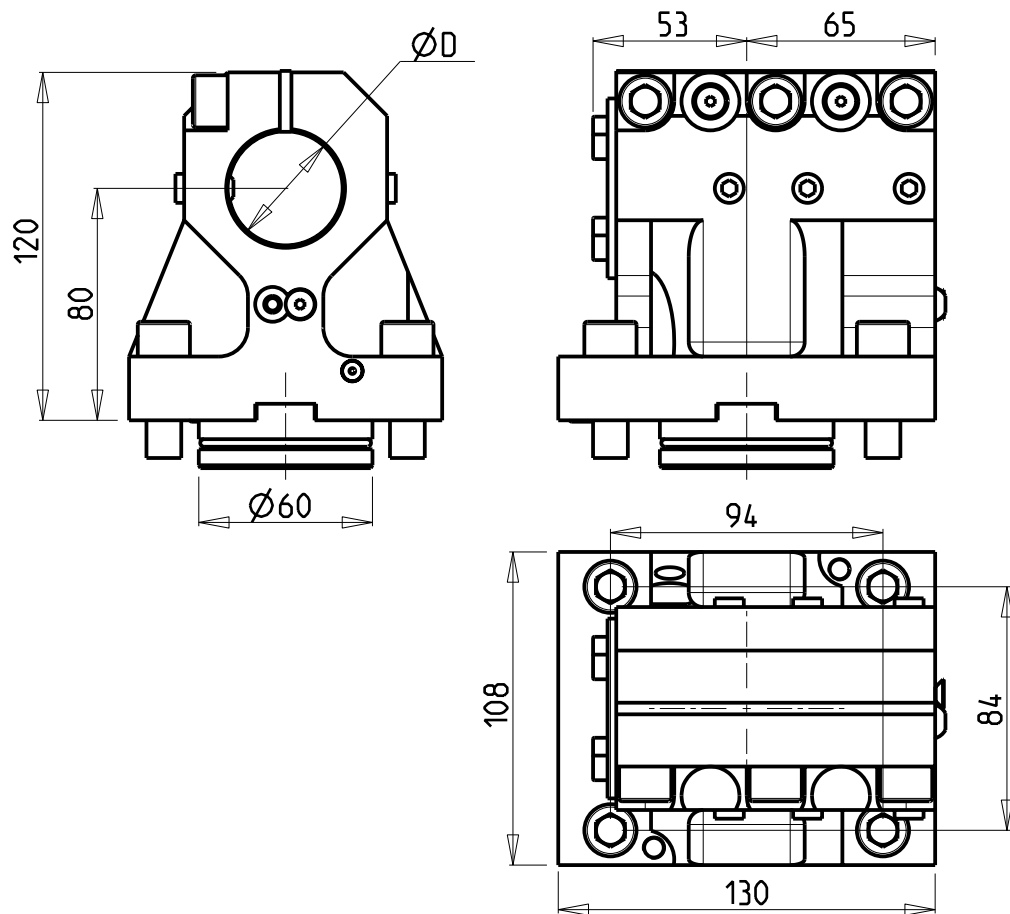

SOLO GUARNIZIONE (OPZIONALE)
 ONLY SEAL (OPTIONAL)
 NUR DICHTUNG (OPTIONAL)
 cod. 0520013

KIT ADDUZIONE INTERNA (OPZIONALE)
 KIT FOR INTERNAL COOLANT (OPTIONAL)
 KIT FUER INTERNE KUEHLMITTELZUFUHR (OPTIONAL)
 Ø40 cod. KIT1003003
 Ø1 1/2" cod. KIT1003004

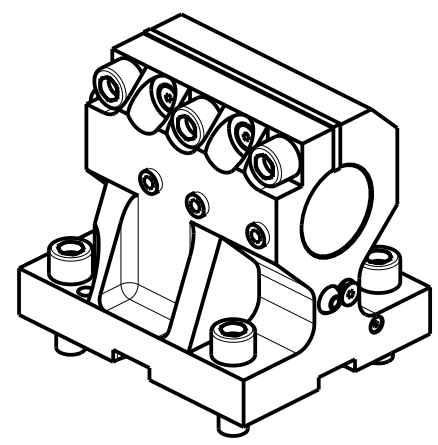

PER BOCCOLE DI RIDUZIONE VEDI PAG. TBL150-1-00
 FOR REDUCING BUSHINGS SEE PAGE TBL150-1-00
 FÜR REDUZIERBUCHSE SIEHE SEITE TBL150-1-00

Cod. MT	N°Utensili N° Tools N° Werkzeuge	Reversibile lato mandrino/contromandrino Reversible sub/main spindle side Umkehrbare Spindel-seite/ Gegenspindel-seite	Lubrificazione int. opzionale Coolant through optional Innenkuhlung Optional	Lubrificazione est. Ext. coolant Aussenkuhlung	Misure Dimensions Masse	Ø.
MNL0114000	1	X	X	X	mm	40
MNL0113810	1	X	X	X	Inch	1 1/2"

TAKISAWA

MOD: TS3000/4000/5000 Y/YS 12 ST. (3 KEYS TURRET)

PORTAUTENSILE ASSIALE PER BARENO Ø40mm / Ø1 1/2" H=80mm

Axial single boring bar holder Ø40mm / Ø1 1/2" H=80mm

Axial Bohrhälter Ø40mm / Ø1 1/2" H=80mm

Subject to change without notice.

M.T. srl
 Via Casino Albini 480
 Tel. 0541/956034-957884
 Fax 0541/956341
 47842 S. GIOVANNI IN M. (RN)
 e-mail: mtma@mtmarchetti.com
 http://www.mtmarchetti.com

PRODUZIONE MODULI ROTANTI



PAGINA TKW 630-7-20

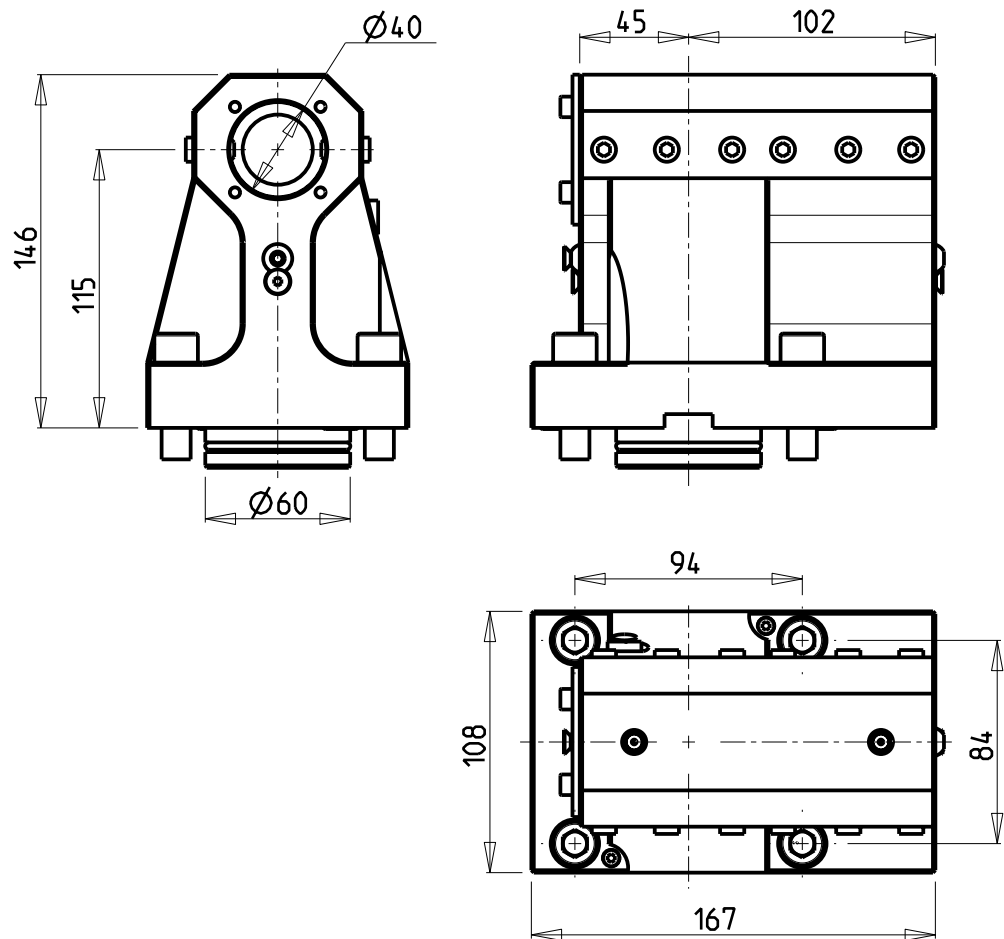

KIT ADDUZIONE INTERNA (OPZIONALE)
 KIT FOR INTERNAL COOLANT (OPTIONAL)
 KIT FUER INTERNE KUEHLMITTELZUFUHR (OPTIONAL)
 Ø40 cod. KIT1000003

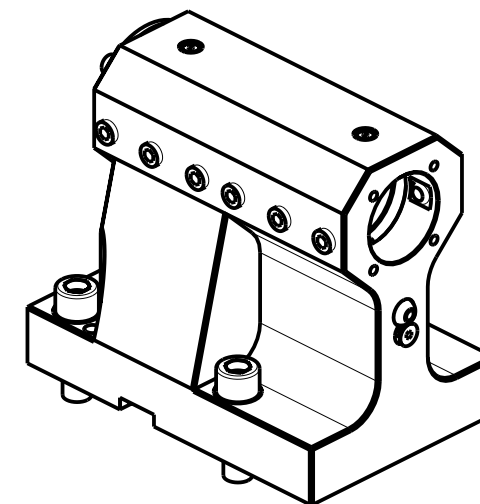
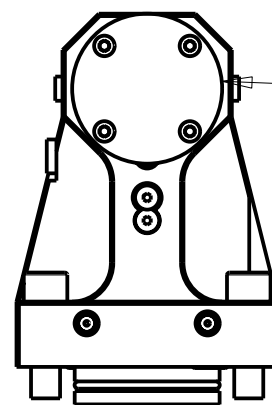

PER BOCCOLE DI RIDUZIONE VEDI PAG. TBL150-1-00
 FOR REDUCING BUSHINGS SEE PAGE TBL150-1-00
 FÜR REDUZIERBUCHSE SIEHE SEITE TBL150-1-00

Cod. MT	N°Utensili N°Tools N°Werkzeuge	Reversibile lato mandrino/contromandrino Reversible sub/main spindle side Umkehrbare Spindelseite/ Gegenspindelseite	Lubrificazione int. opzionale Coolant through optional Innenkühlung Optional	Lubrificazione est. Ext. coolant Aussenkühlung
MNL0604000	1	X	X	X

TAKISAWA
 MOD: TS3000/4000/5000 Y/YS 12 ST. (3 KEYS TURRET)
 PORTAUTENSILE ASSIALE PROLUNGATO PER BARENO Ø40mm H=115mm
 Axial single extended boring bar holder Ø40mm H=115mm
 Axial Bohrhälter verlaengert Ø40mm H=115mm

M.T. srl
 Via Casino Albini 480
 Tel. 0541/956034-957884
 Fax 0541/956341
 47842 S. GIOVANNI IN M. (RN)
 e-mail: mtma@mtmarchetti.com
 http://www.mtmarchetti.com

PRODUZIONE MODULI ROTANTI



PAGINA TKW 760-7-10

Subject to change without notice.

10/2018

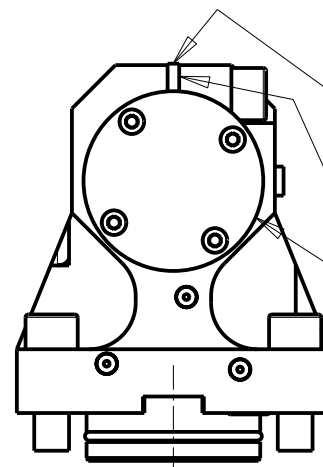
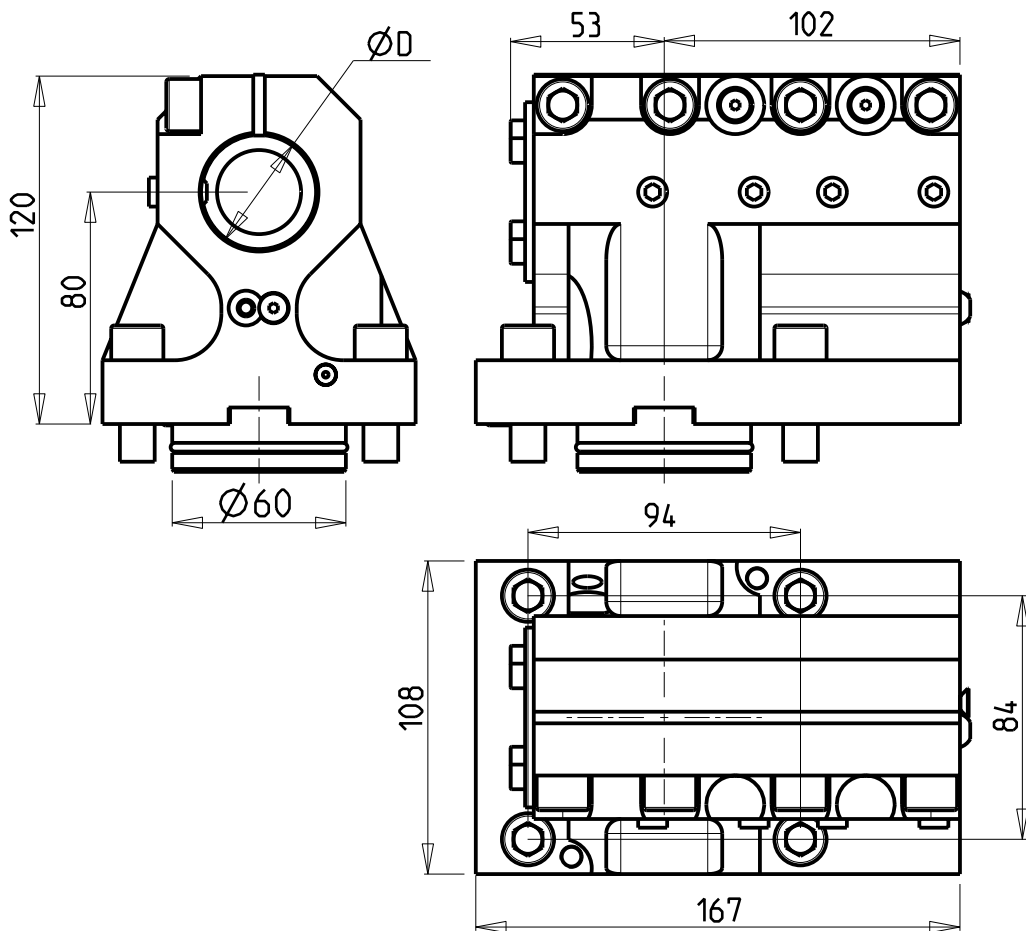

SOLO GUARNIZIONE (OPZIONALE)
 ONLY SEAL (OPTIONAL)
 NUR DICHTUNG (OPTIONAL)
 cod. MNL0310005

KIT ADDUZIONE INTERNA (OPZIONALE)
 KIT FOR INTERNAL COOLANT (OPTIONAL)
 KIT FUER INTERNE KUEHLMITTELZUFUHR (OPTIONAL)
 Ø40 cod. KIT1002003
 Ø1 1/2" cod. KIT1002004

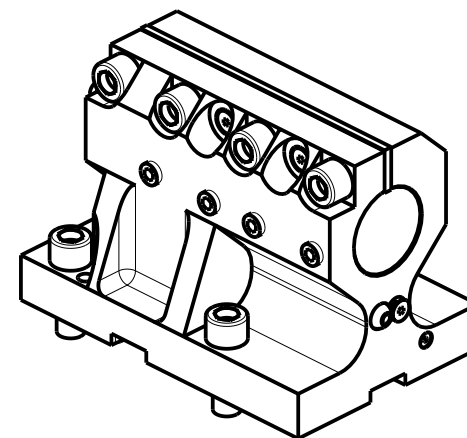

PER BOCCOLE DI RIDUZIONE VEDI PAG. TBL150-1-00
 FOR REDUCING BUSHINGS SEE PAGE TBL150-1-00
 FÜR REDUZIERBUCHSE SIEHE SEITE TBL150-1-00

Cod. MT	N°Utensili N° Tools N° Werkzeuge	Reversibile lato mandrino/contromandrino Reversible sub/main spindle side Umkehrbare Spindel-seite/ Gegenspindel-seite	Lubrificazione int. opzionale Coolant through optional Innenkuhlung Optional	Lubrificazione est. Ext. coolant Aussenkuhlung ..	Misure Dimensions Masse	D
MNL0314000	1	X	X	X	mm	40
MNL0313810	1	X	X	X	inch	1 1/2"

TAKISAWA

MOD: TS3000/4000/5000 Y/YS 12 ST. (3 KEYS TURRET)

PORTAUTENSILE ASSIALE PROLUNGATO PER BARENO Ø40mm / Ø1 1/2" H=80mm

Axial single extended boring bar holder Ø40mm / Ø1 1/2" H=80mm

Axial Bohrhälter verlaengerf Ø40mm / Ø1 1/2" H=80mm

Subject to change without notice.

M.T. srl

Via Casino Albini 480
 Tel. 0541/956034-957884
 Fax 0541/956341

47842 S. GIOVANNI IN M. (RN)
 e-mail: mtma@tmarchetti.com
 http://www.mtmarchetti.com

PRODUZIONE MODULI ROTANTI



PAGINA TKW760-7-20

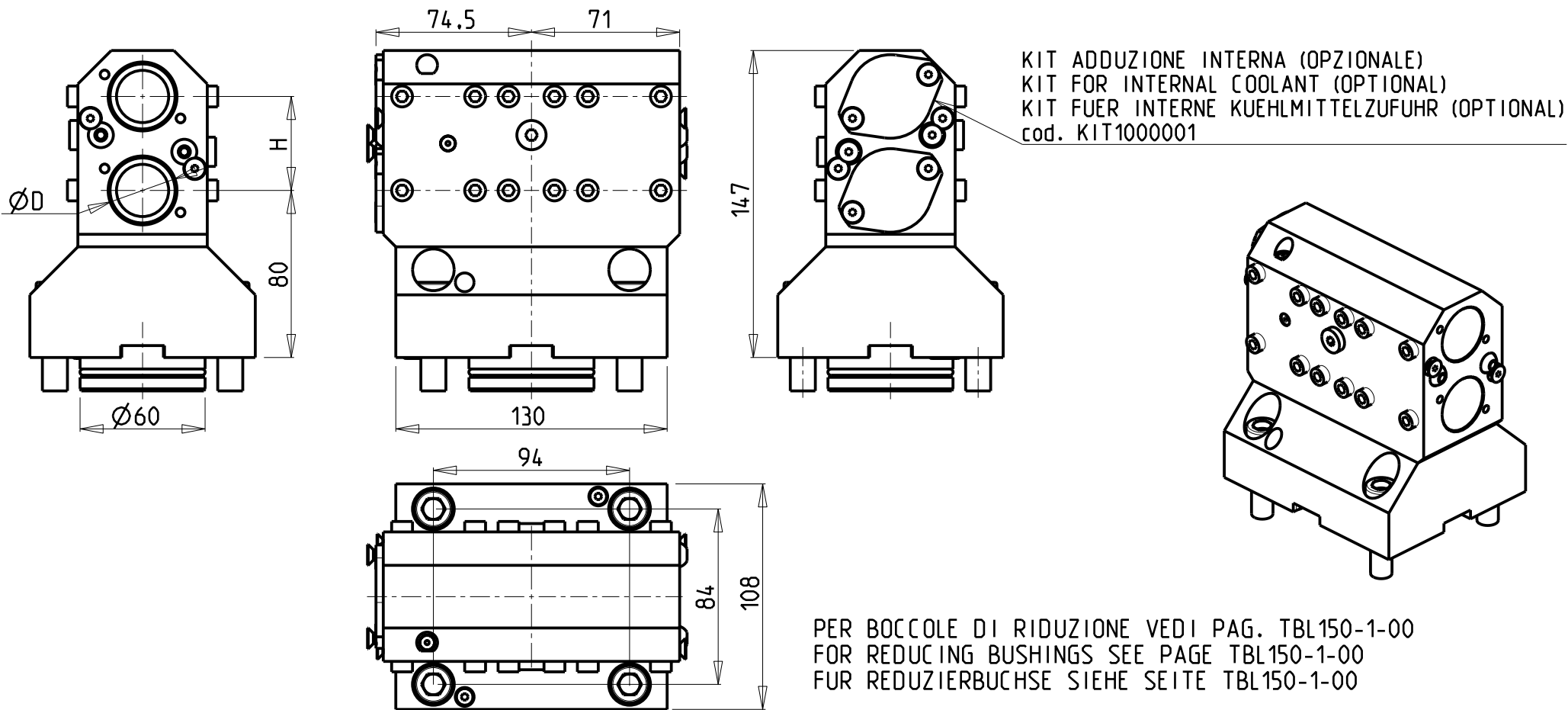

PER BOCCOLE DI RIDUZIONE VEDI PAG. TBL150-1-00
 FOR REDUCING BUSHINGS SEE PAGE TBL150-1-00
 FÜR REDUZIERBUCHSE SIEHE SEITE TBL150-1-00

Cod. MT	Cod. MORI-SEIKI	N°Utensili N°Tools N°Werkzeuge	Lubrificazione int. opzionale Coolant through optional Innenkuehlung Optional	Lubrificazione est. Ext. coolant Aussenkuehlung	Misure Dimensions Masse	D	H
MNL0103200	T10096	2+2	X	X	mm	32	45
MNL0103175	T10100	2+2	X	X	Inch	1 1/4"	1 3/4"

TAKISAWA

MOD: TS3000/4000/5000 Y/YS 12 ST. (3 KEYS TURRET)

PORTAUTENSILE ASSIALE PER BARENO 2+2 POSIZIONI Ø32mm / Ø1 1/4"

Axial 2+2 position boring bar holder Ø32mm / Ø1 1/4"

Axial Bohrhälter 2+2 Positionen Ø32mm / Ø1 1/4"

Subject to change without notice.

M.T. srl

Via Casino Albini 480
 Tel. 0541/956034-957884
 Fax 0541/956341

47842 S. GIOVANNI IN M. (RN)
 e-mail: mtma@mtmarchetti.com
 http://www.mtmarchetti.com

PRODUZIONE MODULI ROTANTI



PAGINA TKW 872-7-00

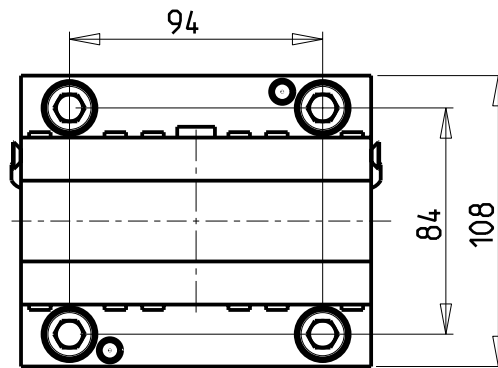
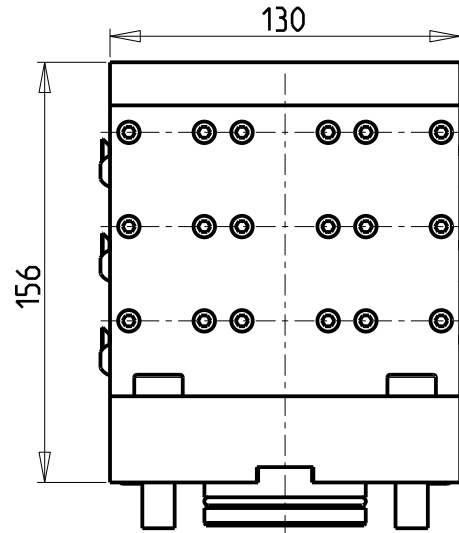
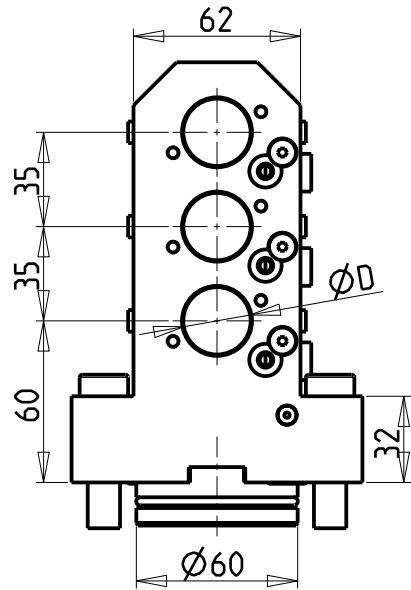

KIT ADDUZIONE INTERNA (OPZIONALE)
 KIT FOR INTERNAL COOLANT (OPTIONAL)
 KIT FUER INTERNE KUEHLMITTELZUFUHR (OPTIONAL)
 cod. KIT1000006

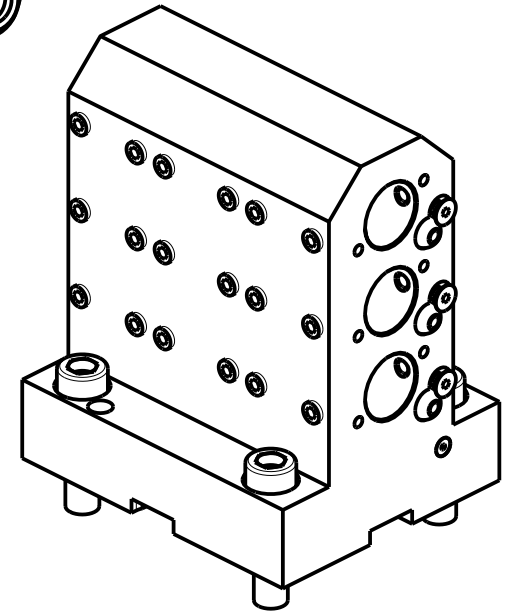

PER BOCCOLE DI RIDUZIONE VEDI PAG. TBL150-1-00
 FOR REDUCING BUSHINGS SEE PAGE TBL150-1-00
 FÜR REDUZIERBUCHSE SIEHE SEITE TBL150-1-00

Cod. MT	N°Utensili N°Tools N°Werkzeuge	Lubrificazione int. opzionale Coolant through optional Innenkuehlung Optional	Lubrificazione est. Ext. coolant Aussenkuehlung	D
MNL0182500	3+3	X	X	25
MNL0182540	3+3	X	X	1"

TAKISAWA
 MOD: TS3000/4000/5000 Y/YS 12 ST. (3 KEYS TURRET)

PORTAUTENSILE ASSIALE PER BARENO 3+3 POSIZIONI Ø25mm / Ø1"
 Axial 3+3 position boring bar holder Ø25mm / Ø1"
 Axial Bohrhälter 3+3 Positionen Ø25mm / Ø1"

Subject to change without notice.

M.T. srl

Via Casino Albini 480
 Tel. 0541/956034-957884
 Fax 0541/956341
 47842 S. GIOVANNI IN M. (RN)
 e-mail: mtma@mtmarchetti.com
 http://www.mtmarchetti.com

PRODUZIONE MODULI ROTANTI



PAGINA TKW 894-7-00

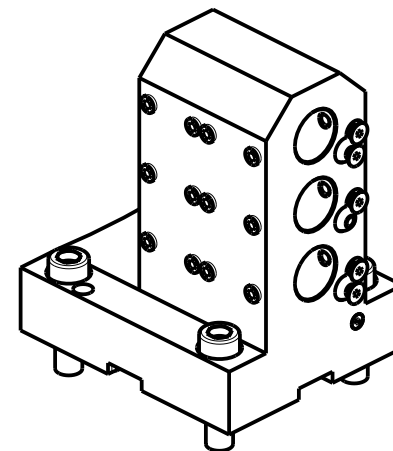
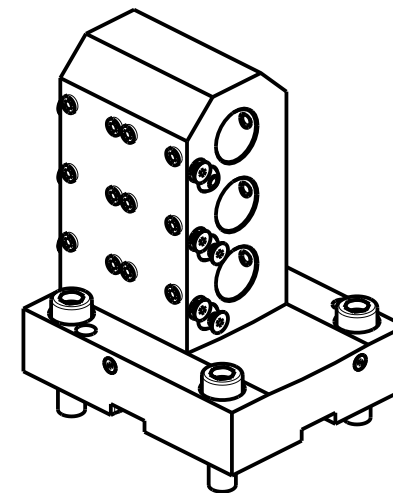
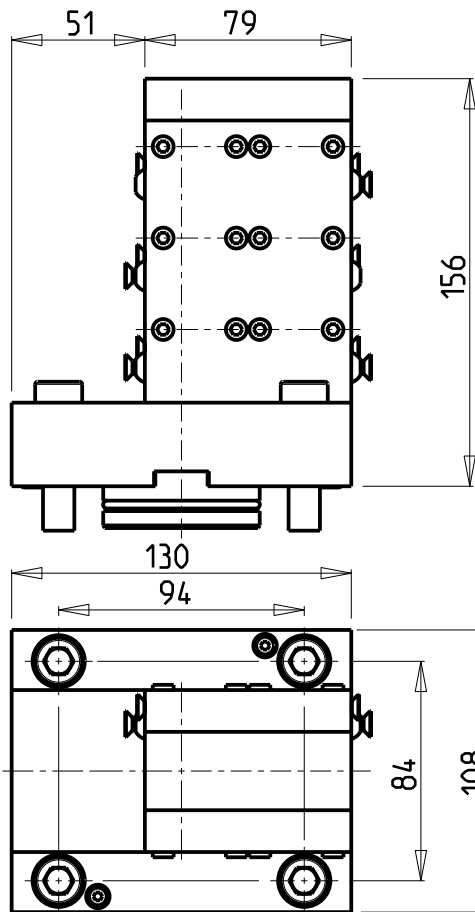
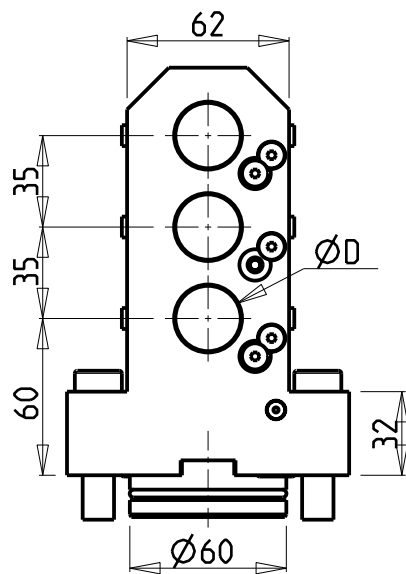

PER BOCCOLE DI RIDUZIONE VEDI PAG. TBL150-1-00
 FOR REDUCING BUSHINGS SEE PAGE TBL150-1-00
 FÜR REDUZIERBUCHSE SIEHE SEITE TBL150-1-00

Cod. MT	N°Utensili N°Tools N°Werkzeuge	Reversibile lato mandrino/contromandrino Reversible sub/main spindle side Umkehrbare Spindel-seite/ Gegenspindel-seite	Lubrificazione est. Ext. coolant Aussenkuehlung	D
MNL0192500	3	X	X	25
MNL0192540	3	X	X	1"

TAKISAWA

MOD: TS3000/4000/5000 Y/YS 12 ST. (3 KEYS TURRET)

PORTAUTENSILE ASSIALE ARRETRATO PER BARENO 3 POSIZIONI Ø25mm / Ø1"

Axial 3 position rear set boring bar holder Ø25mm / Ø1"

Axial Bohrhälter 3 Positionen zurueckversetzt Ø25mm / Ø1"

Subject to change without notice.

M.T. srl

Via Casino Albini 480
 Tel. 0541/956034-957884
 Fax 0541/956341

47842 S. GIOVANNI IN M. (RN)
 e-mail: mtma@mtmarchetti.com
 http://www.mtmarchetti.com

PRODUZIONE MODULI ROTANTI



PAGINA TKW 904-7-00

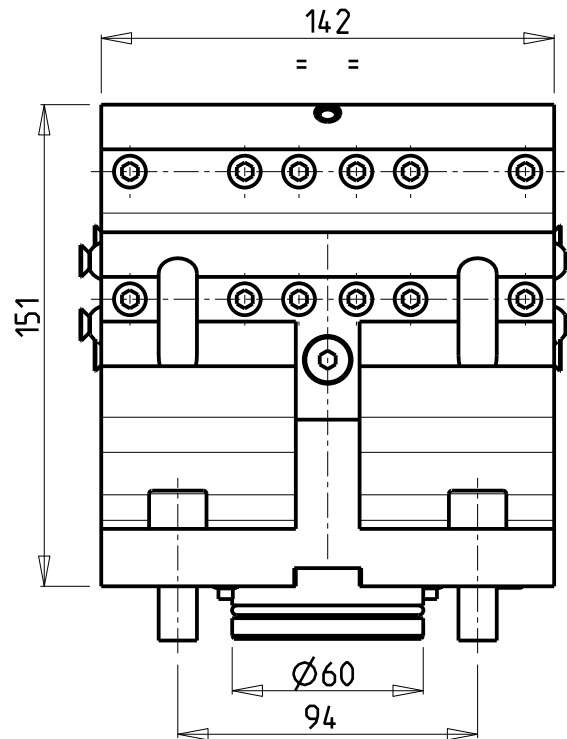
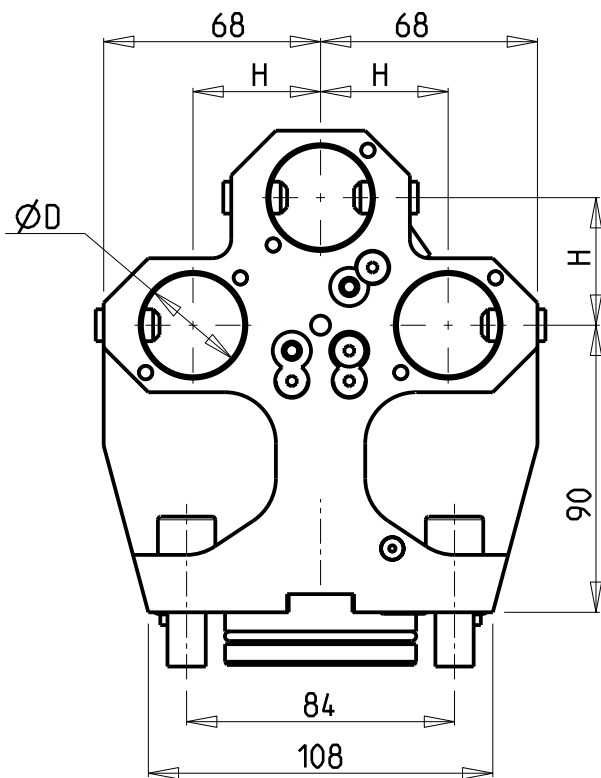

KIT ADDUZIONE INTERNA (OPZIONALE)
 KIT FOR INTERNAL COOLANT (OPTIONAL)
 KIT FUER INTERNE KUEHLMITTELZUFUHR (OPTIONAL)
 cod. KIT1000001

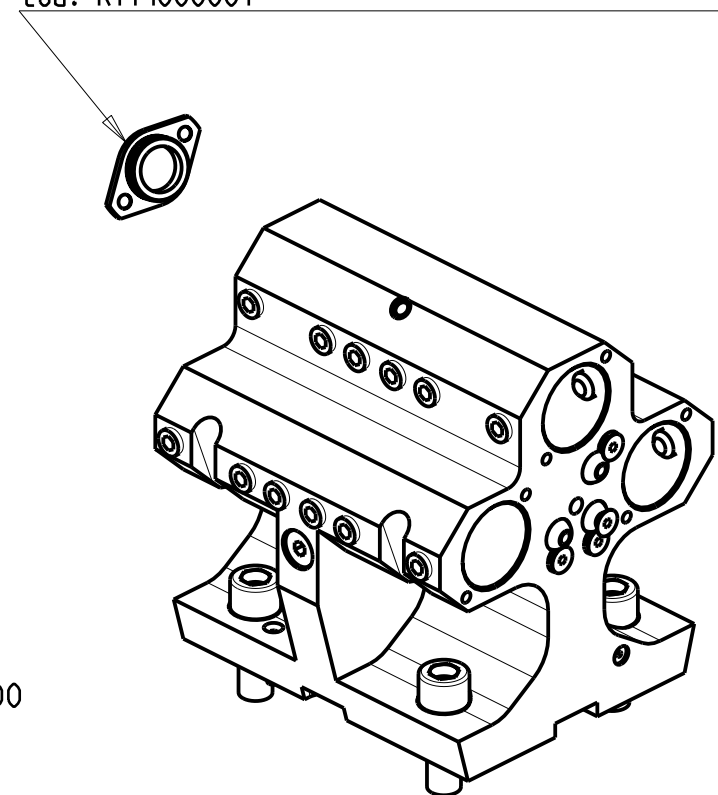

PER BOCCOLE DI RIDUZIONE VEDI PAG. TBL150-1-00
 FOR REDUCING BUSHINGS SEE PAGE TBL150-1-00
 FUR REDUZIERBUCHSE SIEHE SEITE TBL150-1-00

Cod. MT	N°Utensili N°Tools N°Werkzeuge	Lubrificazione int. Coolant through Innenkuehlung	Lubrificazione est. Ext. coolant Aussenkuehlung	Misure Dimensions Masse	D	H
MNL0093200	3+3	X	X	mm	32	40
MNL0093175	3+3	X	X	Inch	1 1/4"	1 1/2"

TAKISAWA
 MOD: TS3000/4000/5000 Y/YS 12 ST. (3 KEYS TURRET)
 PORTAUTENSILE ASSIALE PER BARENO 3+3 POSIZIONI Ø32mm / Ø1 1/4"
 Axial 3+3 position boring bar holder Ø32mm / Ø1 1/4"
 Axial Bohrhalter 3+3 Positionen Ø32mm / Ø1 1/4"

M.T. srl
 Via Casino Albini 480
 Tel. 0541/956034-957884
 Fax 0541/956341
 47842 S. GIOVANNI IN M. (RN)
 e-mail: mtma@mtmarchetti.com
 http://www.mtmarchetti.com

PRODUZIONE MODULI ROTANTI



PAGINA TKW912-7-00

Subject to change without notice.

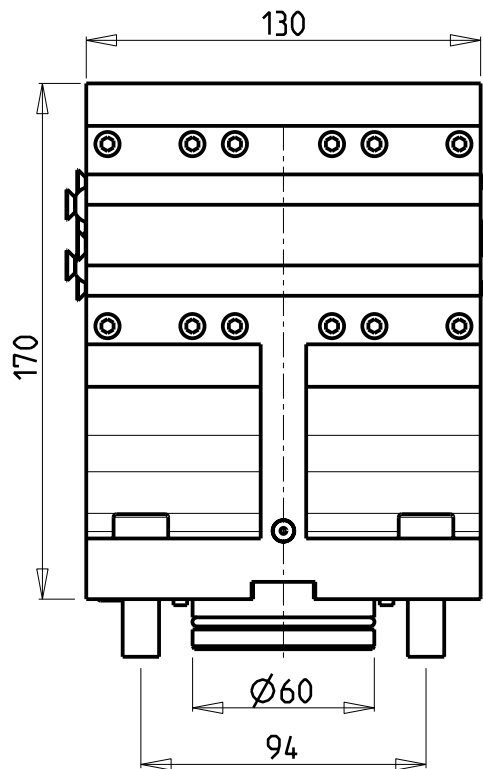
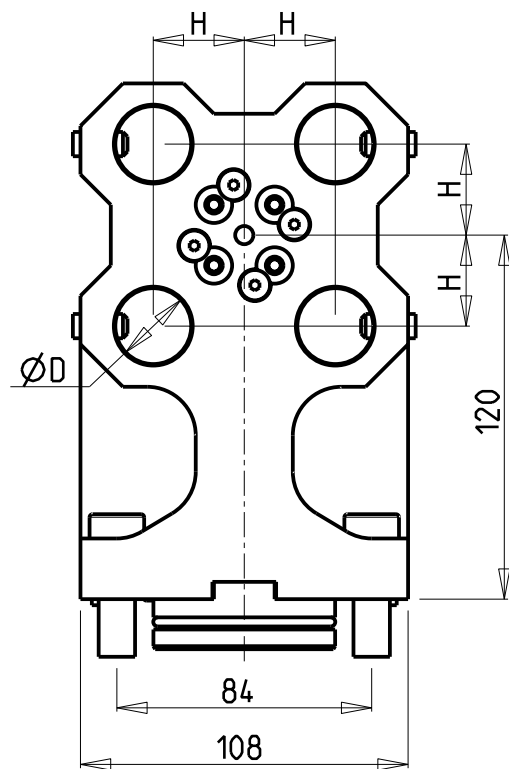

ATTENZIONE - ATTENTION - ACHTUNG

- VERIFICARE LE MISURE DI INGOMBRO PER POSSIBILE INTERFERENZA
- Please check the overall sizes for possible interferences
- Bitte überprüfen sie das Ausmass um mögliche Interferenzen zu vermeiden

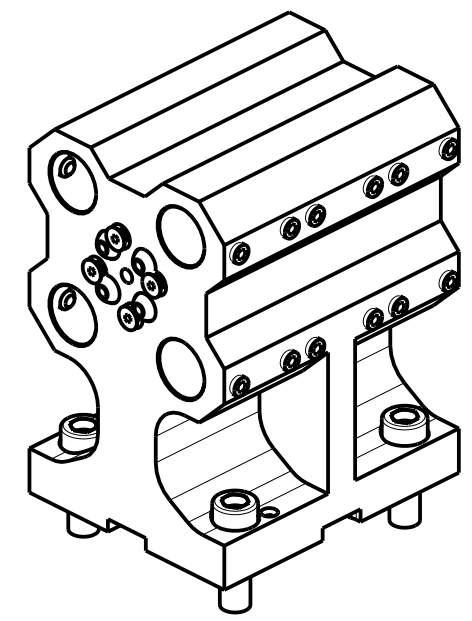

PER BOCCOLE DI RIDUZIONE VEDI PAG. TBL150-1-00
 FOR REDUCING BUSHINGS SEE PAGE TBL150-1-00
 FÜR REDUZIERBUCHSE SIEHE SEITE TBL150-1-00

Cod. MT	N°Utensili N°Tools N°Werkzeuge	Lubrificazione est. Ext. coolant Aussenkuehlung	Misure Dimensions Masse	D	H
MNL0082500	4+4	X	mm	25	30
MNL0082540	4+4	X	Inch	1"	1 1/4"

TAKISAWA
 MOD: TS3000/4000/5000 Y/YS 12 ST. (3 KEYS TURRET)
 PORTAUTENSILE ASSIALE PER BARENO 4+4 POSIZIONI Ø25mm / Ø1"
 Axial 4+4 position boring bar holder Ø25mm / Ø1"
 Axial Bohrhälter 4+4 Positionen Ø25mm / Ø1"

Subject to change without notice.

M.T. srl
 Via Casino Albini 480
 Tel. 0541/956034-957884
 Fax 0541/956341
 47842 S. GIOVANNI IN M. (RN)
 e-mail: mtma@mtmarchetti.com
 http://www.mtmarchetti.com

PRODUZIONE MODULI ROTANTI

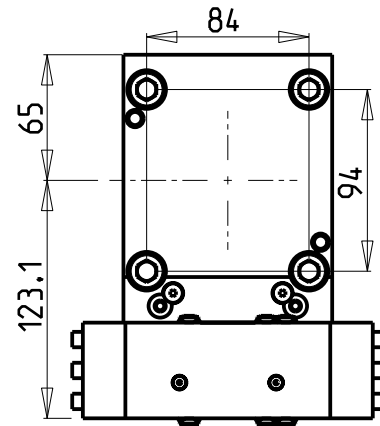
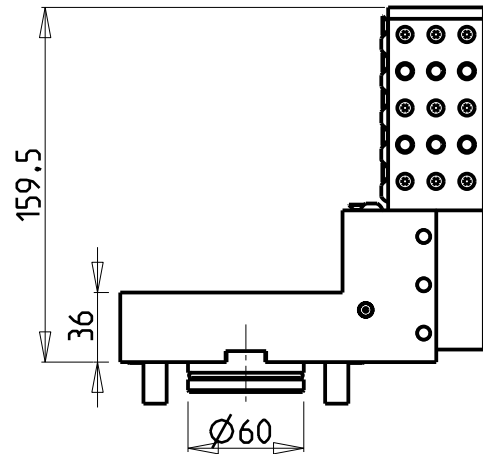
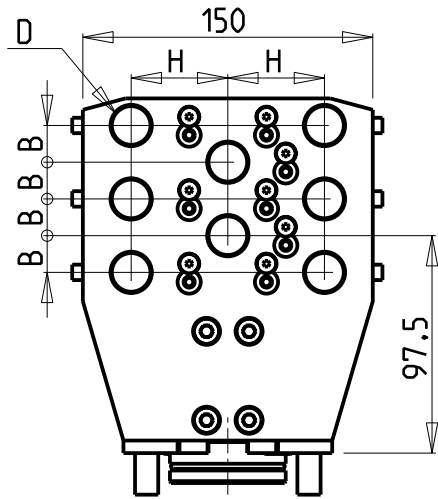
 PAGINA TKW922-7-00

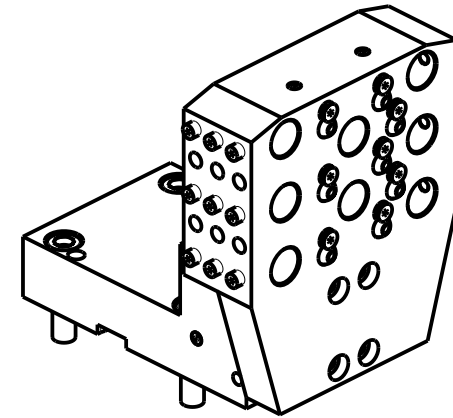

DOTAZIONI - SUPPLIED WITH - AUSSTATTUNG

mm	N*5 Boccole - Bushings - Buchsen \varnothing 16-12-10-8-6 N*1 ER16 Portapinza - Collet holder - Zangenhalter N*1 ER25 Portapinza - Collet holder - Zangenhalter
inch	N*3 Boccole - Bushings - Buchsen \varnothing 1/2"-3/8"-1/4" N*1 ER16 Portapinza - Collet holder - Zangenhalter N*1 ER25 Portapinza - Collet holder - Zangenhalter



ATTENZIONE - ATTENTION - ACHTUNG

- VERIFICARE LE MISURE DI INGOMBRO PER POSSIBILE INTERFERENZA
- Please check the overall sizes for possible interferences
- Bitte überprüfen sie das Ausmass um mögliche Interferenzen zu vermeiden

Cod. MT	N°Utensili N°Tools N°Werkzeuge	Reversibile lato mandrino/contromandrino Reversible sub/main spindle side Umkehrbare Spindel-seite/ Gegenspindel-seite	Lubrificazione est. Ext. coolant Aussenkuehlung	Misure Dimensions Masse	D	B	H
MNL0122000	8	X	X	mm	20	16	50
MNL0121905	8	X	X	Inch	3/4"	5/8"	2"

TAKISAWA

MOD: TS3000/4000/5000 Y/YS 12 ST. (3 KEYS TURRET)

PORTAUTENSILE ASSIALE PER BARENO 8 POSIZIONI \varnothing 20mm / \varnothing 3/4"

Axial 8 position boring bar holder \varnothing 20mm / \varnothing 3/4"

Axial Bohrhälter 8 Positionen \varnothing 20mm / \varnothing 3/4"

Subject to change without notice.

M.T. srl

Via Casino Albini 480
Tel. 0541/956034-957884
Fax 0541/956341
47842 S. GIOVANNI IN M. (RN)
e-mail: mtma@mtmarchetti.com
http://www.mtmarchetti.com

PRODUZIONE MODULI ROTANTI



PAGINA TKW933-7-00

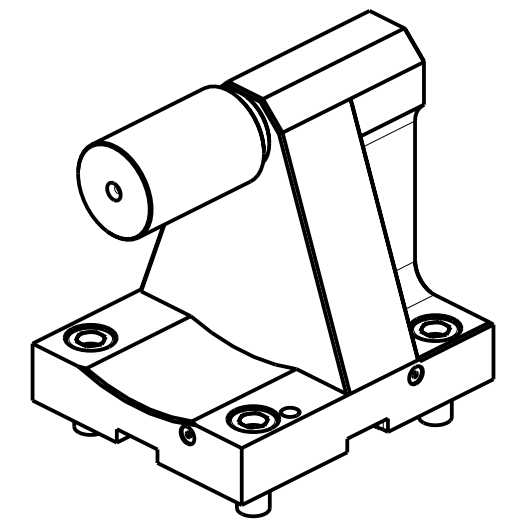
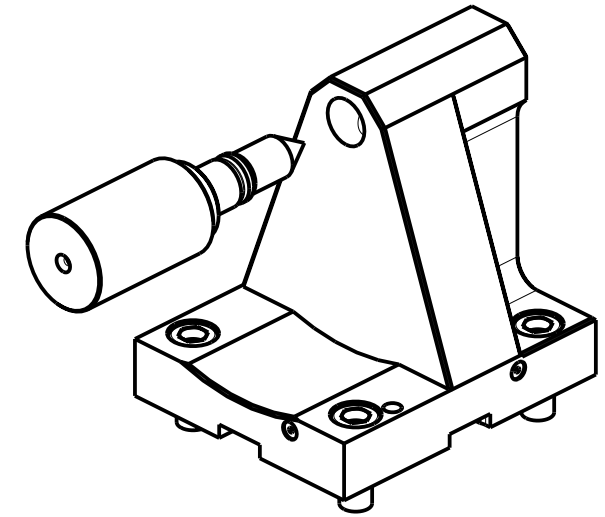
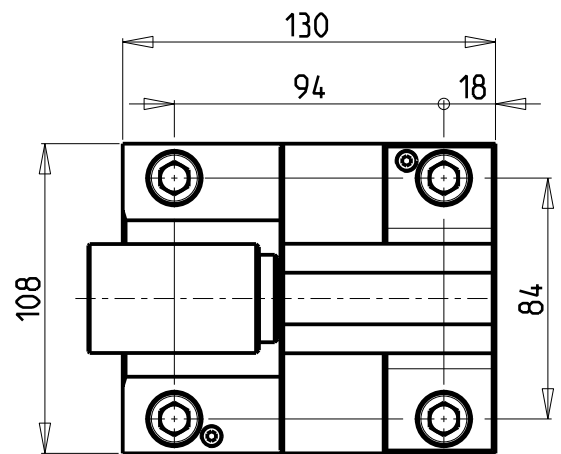
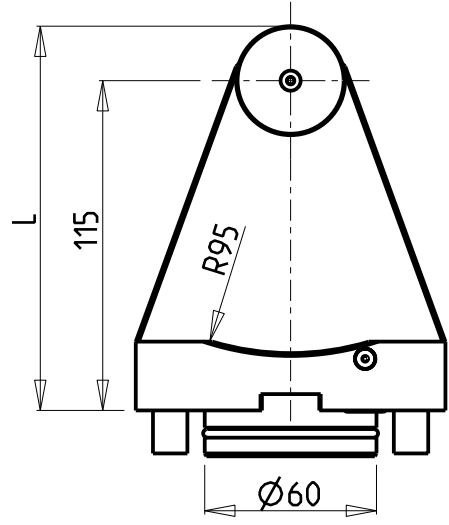
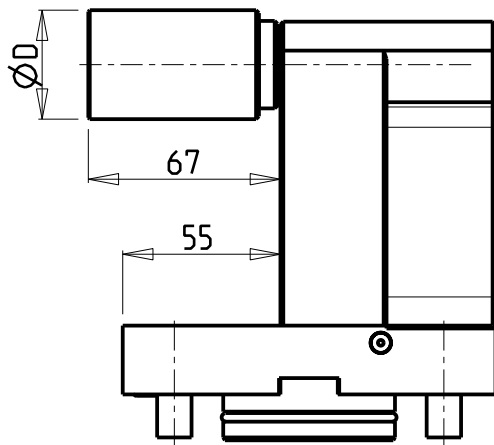

Cod. MT	N°Utensili N°Tools N°Werkzeuge	Reversibile lato mandrino/contromandrino Reversible sub/main spindle side Umkehrbare Spindel-seite/ Gegenspindel-seite	D	L
MNL0360100	1	X	38	134
MNL0360100L	1	X	2"	140.4

TAKISAWA
 MOD: TS3000/4000/5000 Y/YS 12 ST. (3 KEYS TURRET)

CONTROPUNTA PER CONTROMANDRINO
 Tailstock for subspindle
 Gegenspintz fuer Gegenspindel

Subject to change without notice.

M.T. srl
 Via Casino Albini 480
 Tel. 0541/956034-957884
 Fax 0541/956341
 47842 S. GIOVANNI IN M. (RN)
 e-mail: mtma@mtmarchetti.com
 http://www.mtmarchetti.com

PRODUZIONE MODULI ROTANTI



PAGINA TKW950-7-00