

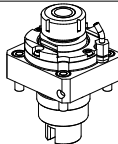

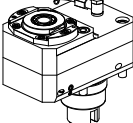

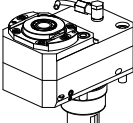
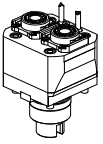

		PAGINA Page Seite
MODULO MOTORIZZATO RADIALE Radial driven tool Radial angetriebenes Werkzeug		TKW 010.2.00
MODULO MOTORIZZATO RADIALE MOLTIPLICATO 1:2 DISASSATO IN Z 70mm Radial geared-up 1=1:2 driven tool re-directed in Z by 70mm Radial angetriebenes Werkzeug uebersetzt 1=1:2 achsversetzt in Z um 70mm		TKW 030.2.30
MODULO MOTORIZZ. RADIALE MOLTIPL. 1:2 PER CONTROMANDR. DISASSATO IN Z 70mm Radial geared-up 1=1:2 driven tool for subspindle re-directed in Z by 70mm Radial angetriebenes Werkzeug uebersetzt 1=1:2 fuer Gegenspindel achsvers. in Z um 70mm		TKW 030.2.31
MODULO MOTORIZZATO RADIALE 2 USCITE IN Y Radial single side twin head driven tool in Y Radial angetriebenes Werkzeug 2 Ausgaenge in Y		TKW 080.2.00 
MODULO MOTORIZZATO ASSIALE Axial driven tool Axial angetriebenes Werkzeug		TKW 150.2.10
MODULO MOTORIZZATO ASSIALE MTSK Axial MTSK driven tool Axial MTSK angetriebenes Werkzeug		TKW 150.2.10.K
MODULO MOTORIZZATO ASSIALE PER CONTROMANDRINO Axial driven tool for subspindle Axial angetriebenes Werkzeug fuer Gegenspindel		TKW 155.2.10
MODULO MOTORIZZATO ASSIALE MTSK PER CONTROMANDRINO Axial MTSK driven tool for subspindle Axial MTSK angetriebenes Werkzeug fuer Gegenspindel		TKW 155.2.10.K
MODULO MOTORIZZATO ASSIALE ARRETRATO Axial rear-set driven tool Axial angetriebenes Werkzeug zurueckversetzt		TKW 180.2.10 
MODULO MOTORIZZATO ASSIALE ARRETRATO PER CONTROMANDRINO Axial rear-set driven tool for subspindle Axial angetriebenes Werkzeug fuer Gegenspindel zurueckversetzt		TKW 185.2.10 
MODULO MOTORIZZATO ASSIALE MOLTIPLICATO 1:2 Axial geared-up 1=1:2 driven tool Axial angetriebenes Werkzeug uebersetzt 1=1:2		TKW 200.2.10
MODULO MOTORIZZ. ASSIALE MOLTIPLIC. 1:2 PER CONTROMANDRINO Axial geared-up 1=1:2 driven tool for subspindle Axial angetriebenes Werkzeug uebersetzt 1=1:2 fuer Gegenspindel		TKW 200.2.11

		PAGINA Page Seite
<p>MODULO MOTORIZZATO ASSIALE BISPORGENTE Axial opposite face twin driven tool Axial angetriebenes Werkzeug halb vorspringend</p>		TKW 240.2.10
<p>MODULO MOTORIZZATO ORIENTABILE ±90° H=65mm ±90° adjustable angle driven tool H=65mm Angetriebenes Werkzeug schwenkbar ±90° H=65mm</p>		TKW 333.2.00 NEW
<p>MODULO MOTORIZZATO ORIENTABILE ±90° CON NONIO DIGITALE H=65mm ±90° adjustable angle driven tool with digital display H=65mm Angetriebenes Werkzeug schwenkbar ±90° mit digital display H=65mm</p>		TKW 333.2.01 NEW

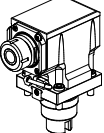
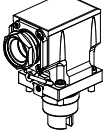
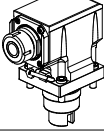
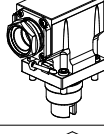
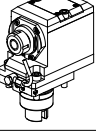

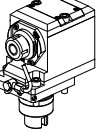
- Chiave inclusa
- Key included
- Schluessel inbegriffen

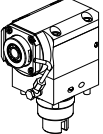
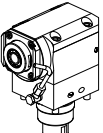
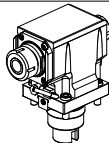
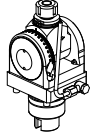
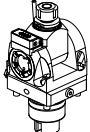
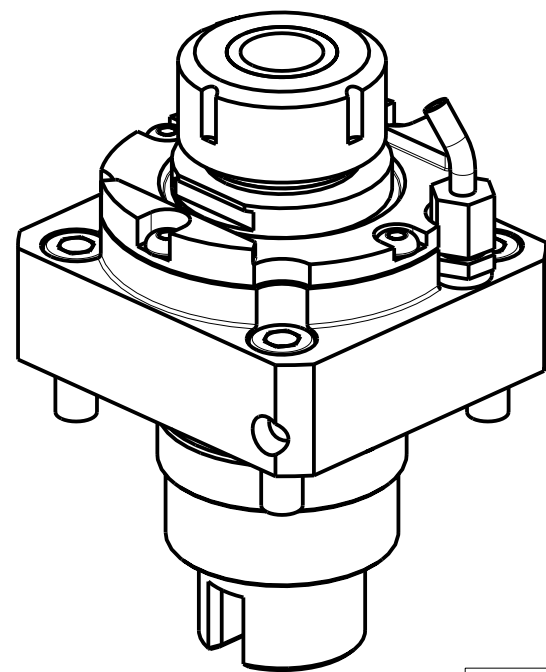
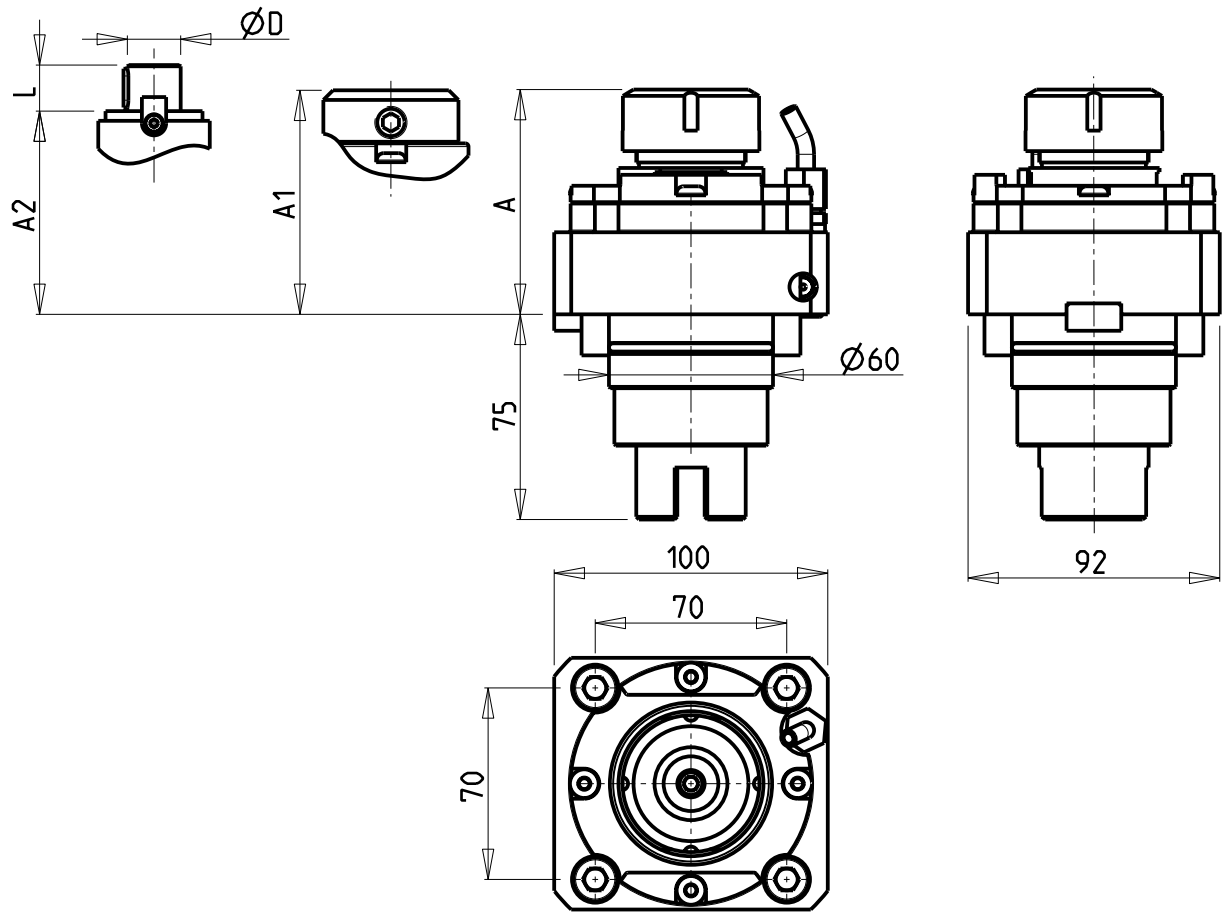
Cod. MT	Cod. TAKISAWA	Mandrino Spindle Spindel	I	RPM	Coppia Max Max Torque Max Drehmoment	Lubr.interna Coolant through Innenkuehlung	Lubrificazione est. Ext. coolant Aussenkuehlung	A	A1	A2	D	L	CHIAVI NON INCLUDE Keys not included Schluessel nicht inbegriffen	
TKW 0120132	HF23001_000	ER32	1:1	6000	65Nm	-	X	82.16	-	-	-	-	CHSTER32	OKU0650004 ▪
TKW 0120232	-	ER32	1:1	6000	65Nm	P=30bar	X	92.66	-	-	-	-	CHSTER32	OKU0650004 ▪
TKW 0120825	-	WELDON25	1:1	6000	65Nm	P=30bar	X	-	86	-	-	-	-	OKU0650004 ▪
TKW 0120522	-	Ø22x19	1:1	6000	65Nm	-	X	-	-	57.5	22	19	CH_VTCROCE_M10 ▪	OKU0650004 ▪

NEW

TAKISAWA

MOD: EX308/310/508/510/708/710/910 - TC350MC - TT350 MC - NEX108/110/908/910 M - LA200M/250M - LA250YS 15ST.
FX-800 - MX-800 - VTL450M

MODULO MOTORIZZATO RADIALE

Radial driven tool

Radial angetriebenes Werkzeug

Subject to change without notice.

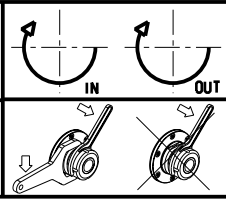

M.T. srl

Via Casino Albini 480
Tel. 0541/956034-957884
Fax 0541/956341
47842 S. GIOVANNI IN M. (RN)
e-mail: mtma@mtmarchetti.com
http://www.mtmarchetti.com

PRODUZIONE MODULI ROTANTI



PAGINA TKW 010-2-00

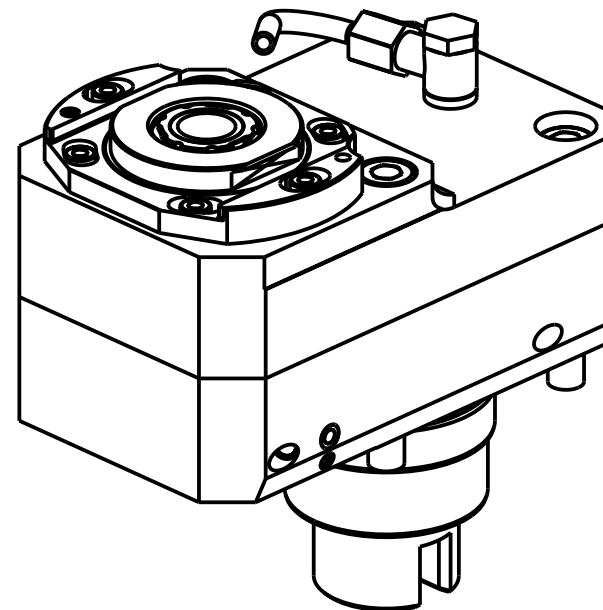
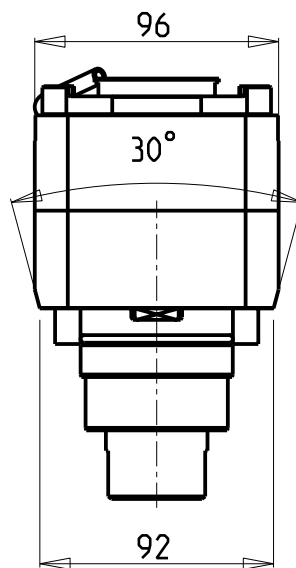
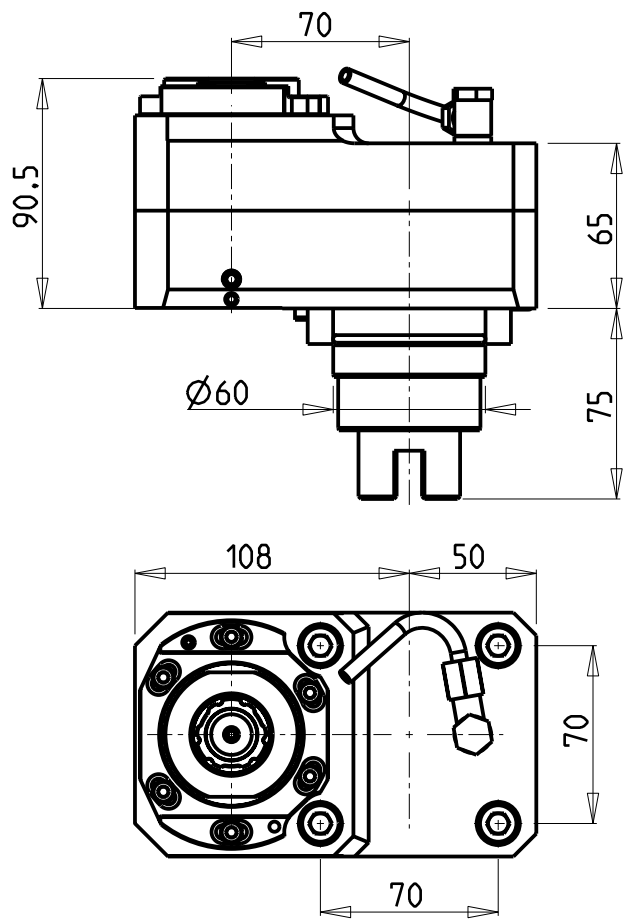

- Chiave inclusa
- Key included
- Schlüssel inbegriffen

Cod. MT	Mandrino Spindle Spindel	i	RPM MAX	Coppia Max Max Torque Max Drehmoment	Lubr.interna Coolant through Innenkuehlung	Lubrificazione est. Ext. coolant Aussenkuehlung	CHIAVI NON INCLUSE Keys not included Schlüssel nicht einbegriffen		
							CHUB27	CHTAER25ZC	OKU0650004
TKW 0430325	ERA25	1:2	12000	30Nm	-	X	CHUB27	CHTAER25ZC	OKU0650004
TKW 0430425	ERA25	1:2	12000	30Nm	P=70bar	X	CHUB27	CHTAER25ZC	OKU0650004

TAKISAWA
 MOD: EX308/310/508/510/708/710/910 - TC350MC - TT350 MC - NEX108/110/908/910 M - LA200M/250M - LA250YS 15ST.
 FX-800 - MX-800 - VTL450M

MODULO MOTORIZZATO RADIALE MOLTIPLICATO I=1:2 DISASSATO IN Z 70mm
 Radial geared-up I=1:2 driven tool re-directed in Z by 70mm
 Radial angetriebenes Werkzeug uebersetzt I=1:2 achsversetzt in Z um 70mm

Subject to change without notice.

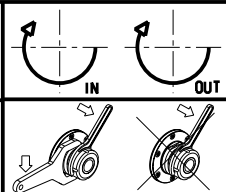

M.T. srl
 Via Casino Albini 480
 Tel. 0541/956034-957884
 Fax 0541/956341
 47842 S. GIOVANNI IN M. (RN)
 e-mail: mtma@mtmarchetti.com
 http://www.mtmarchetti.com

PRODUZIONE MODULI ROTANTI



PAGINA TKW 030-2-30

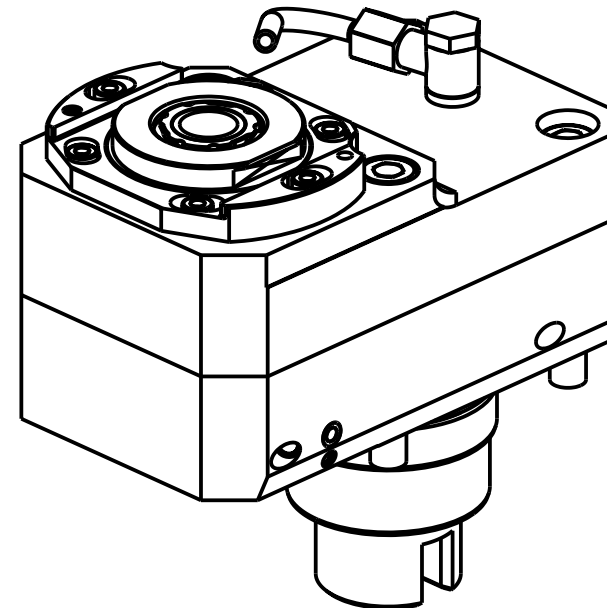
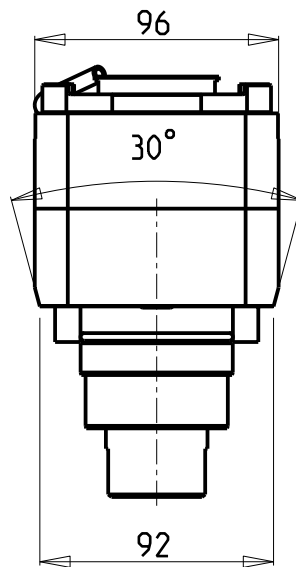
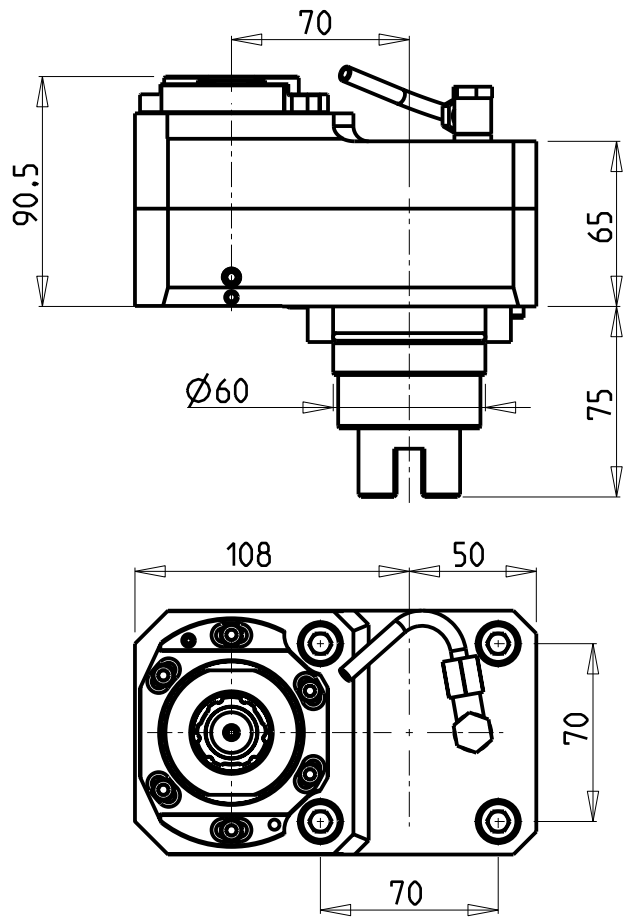

- Chiave inclusa
- Key included
- Schlüssel inbegriffen

Cod. MT	Mandrino Spindle Spindel	i	RPM MAX	Coppia Max Max Torque Max Drehmoment	Lubr.interna Coolant through Innenkuehlung	Lubrificazione est. Ext. coolant Aussenkuehlung	CHIAVI NON INCLUSE Keys not included Schlüssel nicht einbegriffen		
							CHUB27	CHTAER25ZC	OKU0650004
TKW 0430525	ERA25	1:2	12000	30Nm	-	X	CHUB27	CHTAER25ZC	OKU0650004
TKW 0430625	ERA25	1:2	12000	30Nm	P=70bar	X	CHUB27	CHTAER25ZC	OKU0650004

TAKISAWA

MOD: EX308/310/508/510/708/710/910 - TT350 MC - NEX908/910 - LA250YS 15ST. - FX-800 - MX-800

MODULO MOTORIZZATO RADIALE MOLTIPLICATO I=1:2 PER CONTROMANDRINO DISASSATO IN Z 70mm

Radial geared-up I=1:2 driven tool for subspindle re-directed in Z by 70mm

Radial angetriebenes Werkzeug uebersetzt I=1:2 fuer Gegenspindel achsversetzt in Z um 70mm

Subject to change without notice.

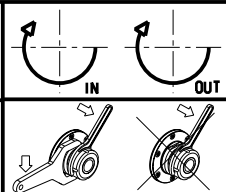

M.T. srl
Via Casino Albini 480
Tel. 0541/956034-957884
Fax 0541/956341
47842 S. GIOVANNI IN M. (RN)
e-mail: mtma@mtmarchetti.com
http://www.mtmarchetti.com

PRODUZIONE MODULI ROTANTI



PAGINA TKW 030-2-31

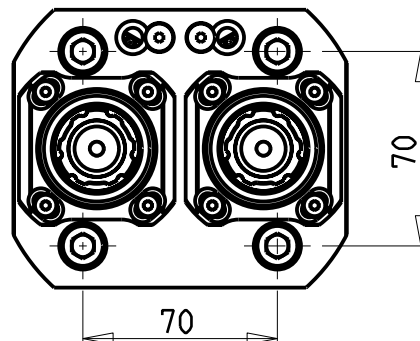
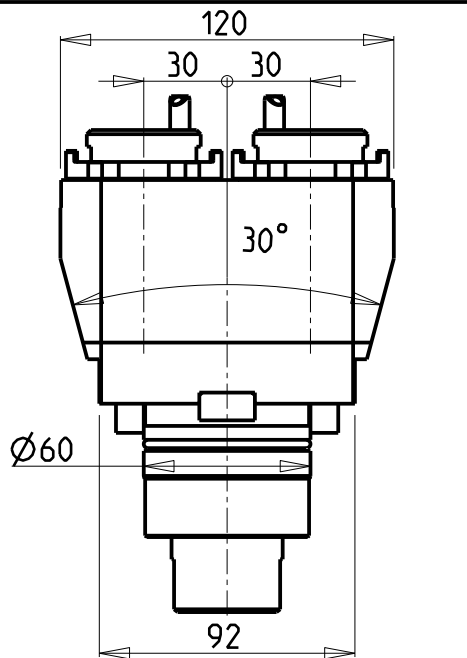
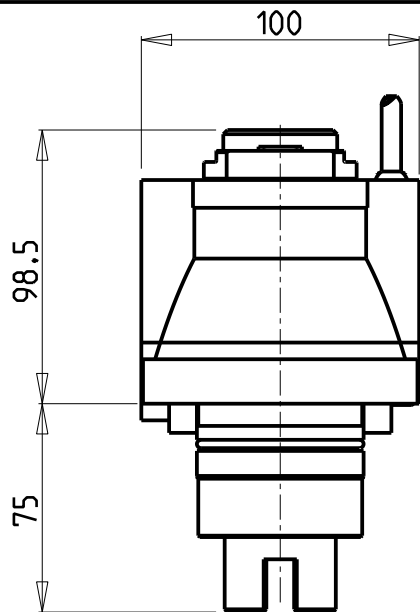

ATTENZIONE - ATTENTION - ACHTUNG

- Per lo smontaggio degli utensili utilizzare sempre la chiave di contrasto come indicato nel manuale d'uso.
- For disassembly of the tools use always the contrast key as mentioned in the user instructions.
- Fuer das Abmontieren der Werkzeuge immer den Gegenschlüssel benutzen wie in der Bedienungsanleitung erwäohnt.

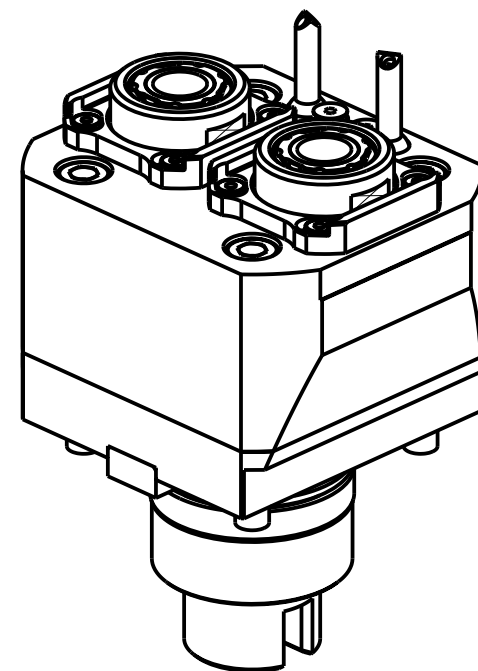

- Chiave inclusa
- Key included
- Schlüssel inbegriffen

Cod. MT	Mandrino Spindle Spindel	I	RPM	Coppia Max Max Torque Max Drehmoment	Lubrificazione est. Ext. coolant Aussenkuehlung	CHIAVI NON INCLUSE Keys not included Schlüssel nicht einbegriffen			
TKW 0730325	ERA25	1:1	6000	50Nm	X	CHUB27	CHTAER25ZC *	OKU0290009 *	NEW

TAKISAWA
MOD: NEX108/110/908/910 - LA250YS 15ST. - FX-800 - MX-800

MODULO MOTORIZZATO RADIALE 2 USCITE IN Y
Radial single side twin head driven tool in Y
Radial angetriebenes Werkzeug 2 Ausgaenge in Y

Subject to change without notice.

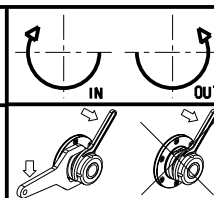

M.T. srl
Via Casino Albini 480
Tel. 0541/956034-957884
Fax 0541/956341
47842 S. GIOVANNI IN M. (RN)
e-mail: mtma@mtmarchetti.com
http://www.mtmarchetti.com

PRODUZIONE MODULI ROTANTI



PAGINA TKW080-2-00

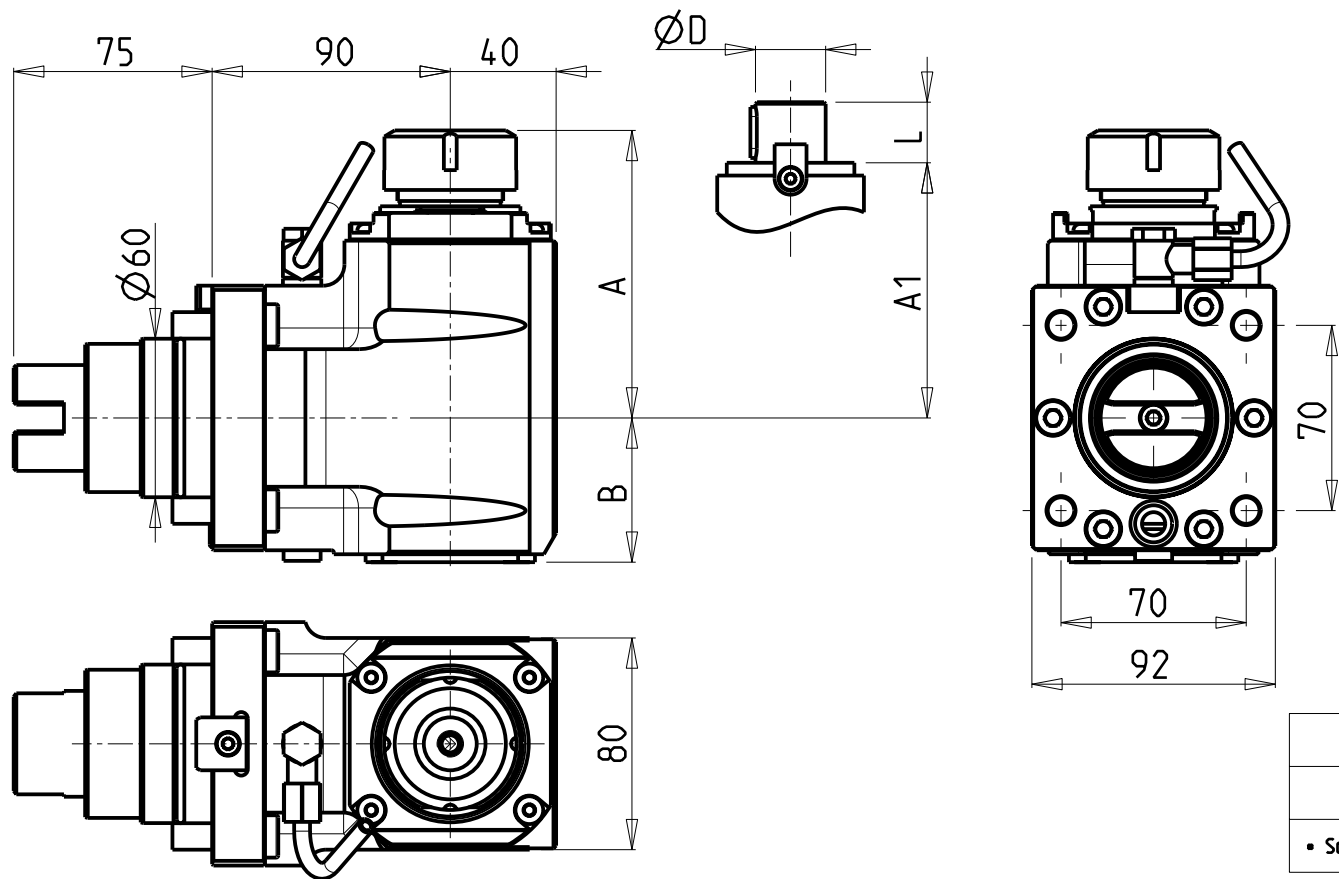

ATTENZIONE - ATTENTION - ACHTUNG

- Per lo smontaggio degli utensili utilizzare sempre la chiave di contrasto come indicato nel manuale d'uso.
- For disassembly of the tools use always the contrast key as mentioned in the user instructions.
- Fuer das Abmontieren der Werkzeuge immer den Gegenschlüssel benutzen wie in der Bedienungsanleitung erwaeht.

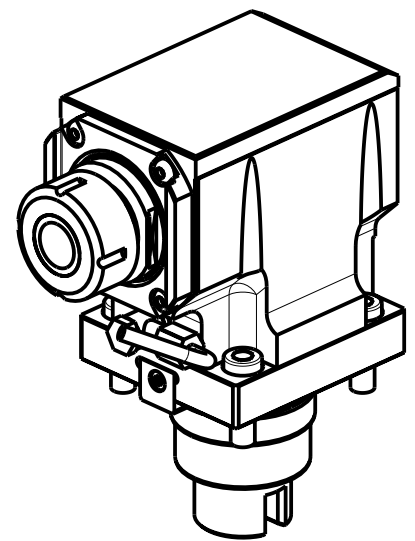

- Chiave inclusa
- Key included
- Schluessel inbegriffen

Cod. MT	Cod. TAKISAWA	Mandrino Spindle Spindel	I	RPM	Coppia Max Max Torque Max Drehmoment	Lubr.interna Coolant through Innenkuehlung	Lubr.esterna Ext. coolant Aussenkuehlung	A	A1	D	L	B	CHIAVI NON INCLUDE Keys not included Schluessel nicht einbegriffen	
TKW 0110132	HF23001-000Z	ER32	1:1	6000	65Nm	-	X	108.7	-	-	-	54.5	CHSTER32	OKU0650004 •
TKW 0110232	-	ER32	1:1	6000	65Nm	P=70bar	X	108.7	-	-	-	67	CHSTER32	OKU0650004 •
TKW 0110527	-	Ø27x21	1:1	6000	65Nm	-	X	-	85	27	21	54.5	CH_VTCROCE_M12 •	OKU0650004 • NEW

TAKISAWA
 MOD: EX308/310/508/510/708/710/910 - TC350MC - TT350 MC - NEX108/110/908/910 M - LA200M/250M - LA250YS 15ST.
 FX-800 - MX-800 - VTL450M

MODULO MOTORIZZATO ASSIALE
 Axial driven tool
 Axial angetriebenes Werkzeug

Subject to change without notice.

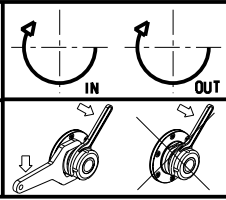

M.T. srl
 Via Casino Albini 480
 Tel. 0541/956034-957884
 Fax 0541/956341
 47842 S. GIOVANNI IN M. (RN)
 e-mail: mtma@mtmarchetti.com
 http://www.mtmarchetti.com

PRODUZIONE MODULI ROTANTI

PAGINA TKW 150-2-10

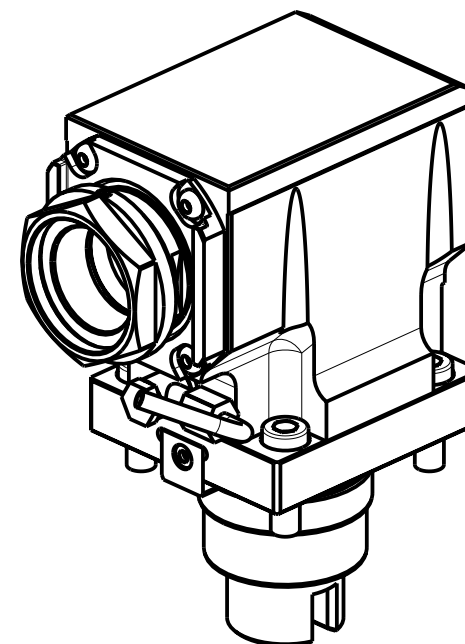
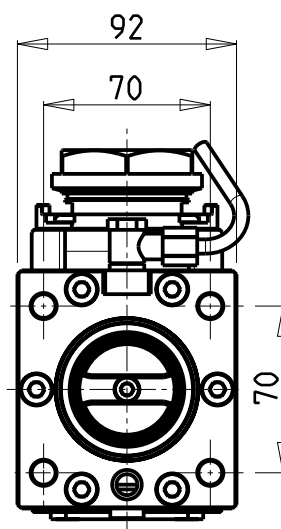
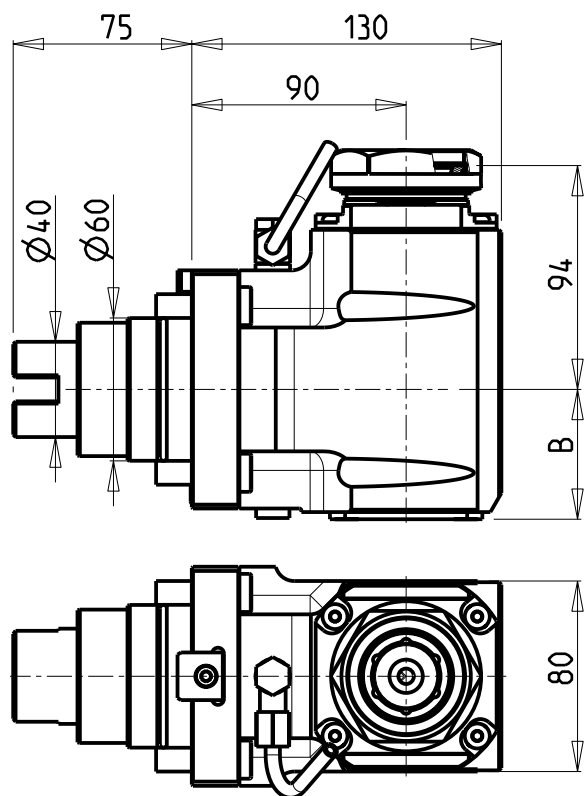

- Chiave inclusa
- Key included
- Schlüssel inbegriffen

PER PORTAUTENSILI MODULARI MTSK-50 VEDI PAG. TBL300-1-50
 FOR MTSK-50 QUICK CHANGE TOOLHOLDERS CLAMPINGS SEE PAGE TBL300-1-50
 FUER MTSK-50 MODULARE WERKZEUGAUFNAHMEN SIEHE SEITE TBL300-1-50

Cod. MT	Mandrino Spindle Spindel	I	RPM	Coppia Max Max Torque Max Drehmoment	Lubr.interna Coolant through Innenkuehlung	Lubr. esterna Ext. coolant Aussenkuehlung	B	CHIAVI NON INCLUDE Keys not included Schlüssel nicht einbegriffen	
TKW 0420150	MTSK-50	1:1	6000	65Nm	-	X	54,5	CHUB55	OKU0650004
TKW 0420250	MTSK-50	1:1	6000	65Nm	P=70bar	X	67	CHUB55	OKU0650004

TAKISAWA

MOD: EX308/310/508/510/708/710/910 - TC350MC - TT350 MC - NEX108/110/908/910 M - LA200M/250M - LA250YS 15ST.
 FX-800 - MX-800 - VTL450M

MODULO MOTORIZZATO ASSIALE MTSK

Axial MTSK driven tool

Axial MTSK angetriebenes Werkzeug

Subject to change without notice.

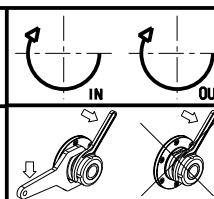

M.T. srl
 Via Casino Albini 480
 Tel. 0541/956034-957884
 Fax 0541/956341
 47842 S. GIOVANNI IN M. (RN)
 e-mail: mtma@mtmarchetti.com
 http://www.mtmarchetti.com

PRODUZIONE MODULI ROTANTI



PAGINA TKW 150-2-10-K

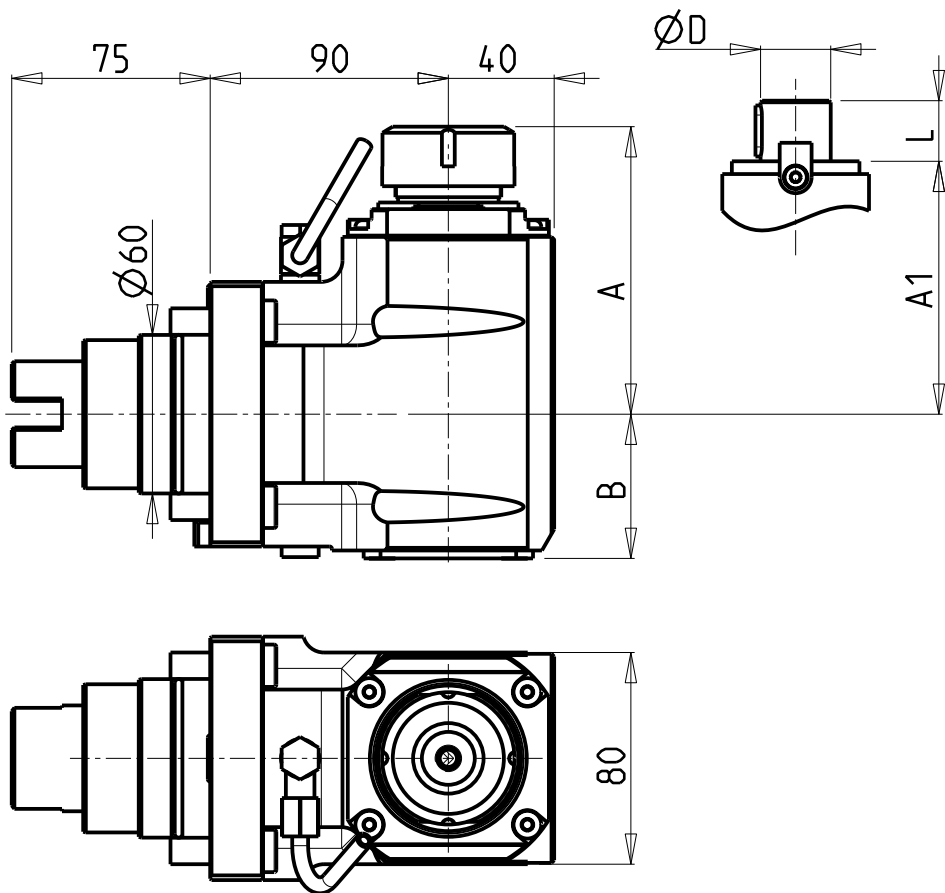

ATTENZIONE - ATTENTION - ACHTUNG

- Per lo smontaggio degli utensili utilizzare sempre la chiave di contrasto come indicato nel manuale d'uso.
- For disassembly of the tools use always the contrast key as mentioned in the user instructions.
- Fuer das Abmontieren der Werkzeuge immer den Gegenschlüssel benutzen wie in der Bedienungsanleitung erwaeht.

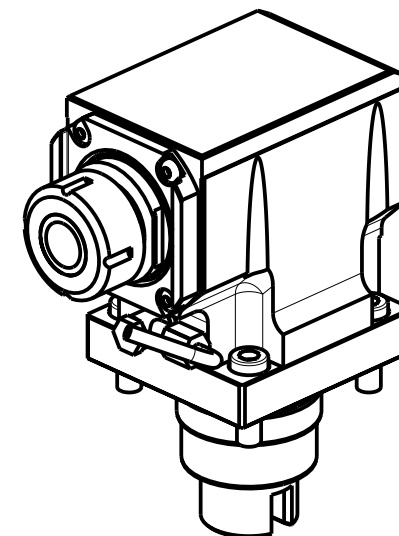
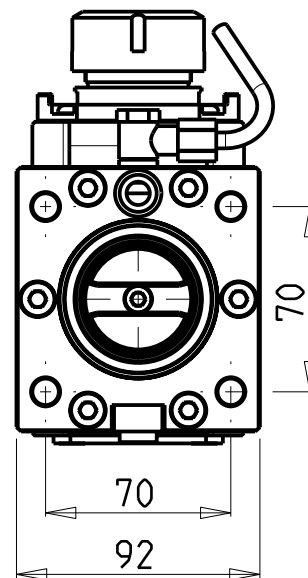

- Chiave inclusa
- Key included
- Schluessel inbegriffen

Cod. MT	Mandrino Spindle Spindel	I	RPM	Coppia Max Max Torque Max Drehmoment	Lubr.interna Coolant through Innenkuehlung	Lubr.esterna Ext. coolant Ausseinkuehlung	A	A1	D	L	B	CHIAVI NON INCLUDE Keys not included Schluessel nicht einbegriffen	
TKW 0110332	ER32	1:1	6000	65Nm	-	X	108.7	-	-	-	54.5	CHSTER32	OKU0650004 ▪
TKW 0110432	ER32	1:1	6000	65Nm	P=70bar	X	108.7	-	-	-	67	CHSTER32	OKU0650004 ▪
TKW 0111527	Ø27x21	1:1	6000	65Nm	-	X	-	85	27	21	54.5	CH_VTCROCE_M12 ▪	OKU0650004 ▪

NEW

TAKISAWA

MOD: EX308/310/508/510/708/710/910 - TT350 MC - NEX908/910 - LA250YS 15ST. - FX-800 - MX-800

MODULO MOTORIZZATO ASSIALE PER CONTROMANDRINO

Axial driven tool for subspindle

Axial angetriebenes Werkzeug fuer Gegenspindel

Subject to change without notice.

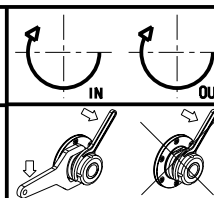

M.T. srl

Via Casino Albini 480
Tel. 0541/956034-957884
Fax 0541/956341
47842 S. GIOVANNI IN M. (RN)
e-mail: mtma@mtmarchetti.com
http://www.mtmarchetti.com

PRODUZIONE MODULI ROTANTI



PAGINA TKW 155-2-10

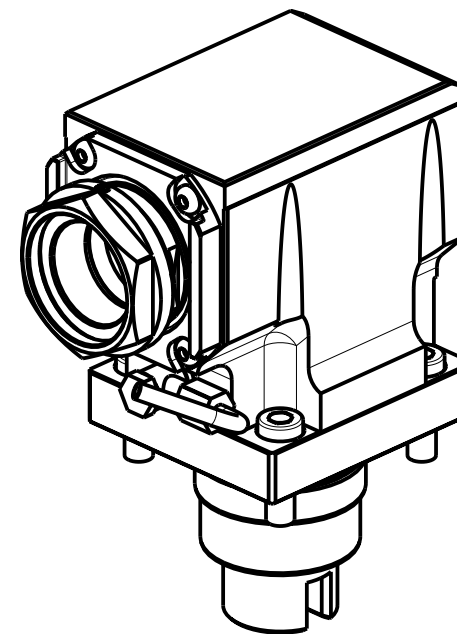
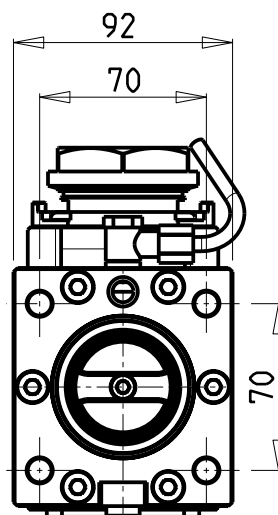
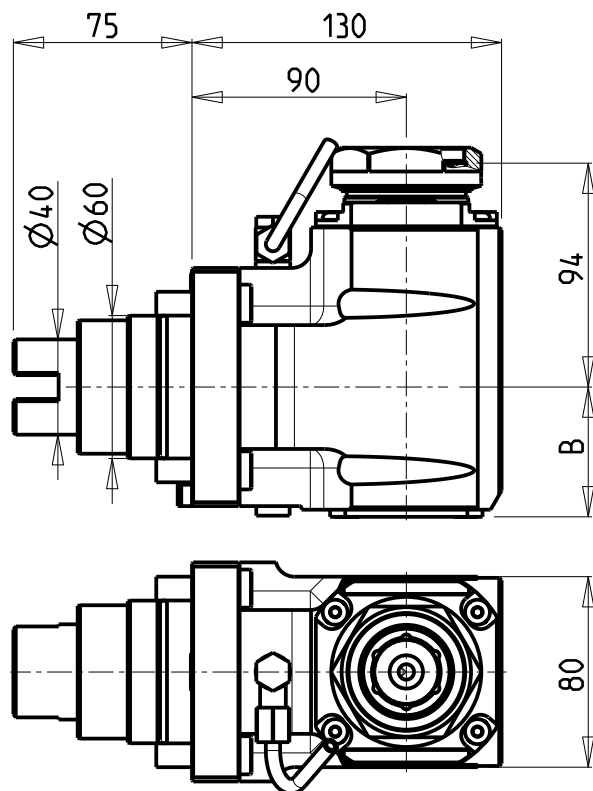

- Chiave inclusa
- Key included
- Schlüssel inbegriffen

PER PORTAUTENSILI MODULARI MTSK-50 VEDI PAG. TBL300-1-50
 FOR MTSK-50 QUICK CHANGE TOOLHOLDERS CLAMPINGS SEE PAGE TBL300-1-50
 FUER MTSK-50 MODULARE WERKZEUGAUFNAHMEN SIEHE SEITE TBL300-1-50

Cod. MT	Mandrino Spindle Spindel	I	RPM	Coppia Max Max Torque Max Drehmoment	Lubr.interna Coolant through Innenkuehlung	Lubr. esterna Ext. coolant Aussenkuehlung	B	CHIAVI NON INCLUDE Keys not included Schlüssel nicht einbegriffen	
TKW 0420350	MTSK-50	1:1	6000	65Nm	-	X	54.5	CHUB55	OKU0650004
TKW 0420450	MTSK-50	1:1	6000	65Nm	P=70bar	X	67	CHUB55	OKU0650004

TAKISAWA

MOD: EX308/310/508/510/708/710/910 - TT350 MC - NEX908/910 - LA250YS 15ST. - FX-800 - MX-800

MODULO MOTORIZZATO ASSIALE MTSK PER CONTROMANDRINO

Axial MTSK driven tool for subspindle

Axial MTSK angetriebenes Werkzeug fuer Gegenspindel

Subject to change without notice.

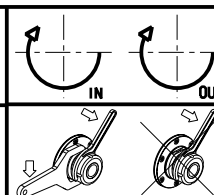

M.T. srl
 Via Casino Albini 480
 Tel. 0541/956034-957884
 Fax 0541/956341
 47842 S. GIOVANNI IN M. (RN)
 e-mail: mtma@mtmarchetti.com
 http://www.mtmarchetti.com

PRODUZIONE MODULI ROTANTI



PAGINA TKW 155-2-10-K

ATTENZIONE - ATTENTION - ACHTUNG

- VERIFICARE LE MISURE DI INGOMBRO PER POSSIBILE INTERFERENZA SU ALCUNI MODELLI DI MACCHINE
- Please check the overall sizes for possible interferences on some machine models
- Bitte überprüfen sie das ausmass um mögliche interferenzen auf einigen maschinen modellen zu vermeiden

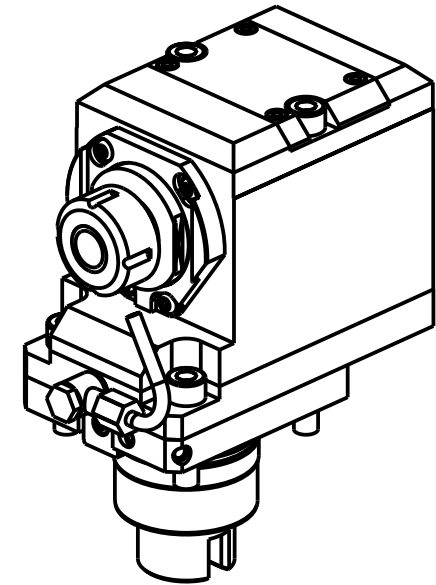
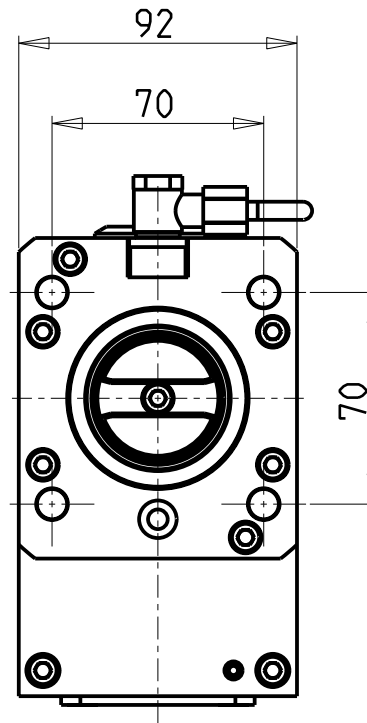
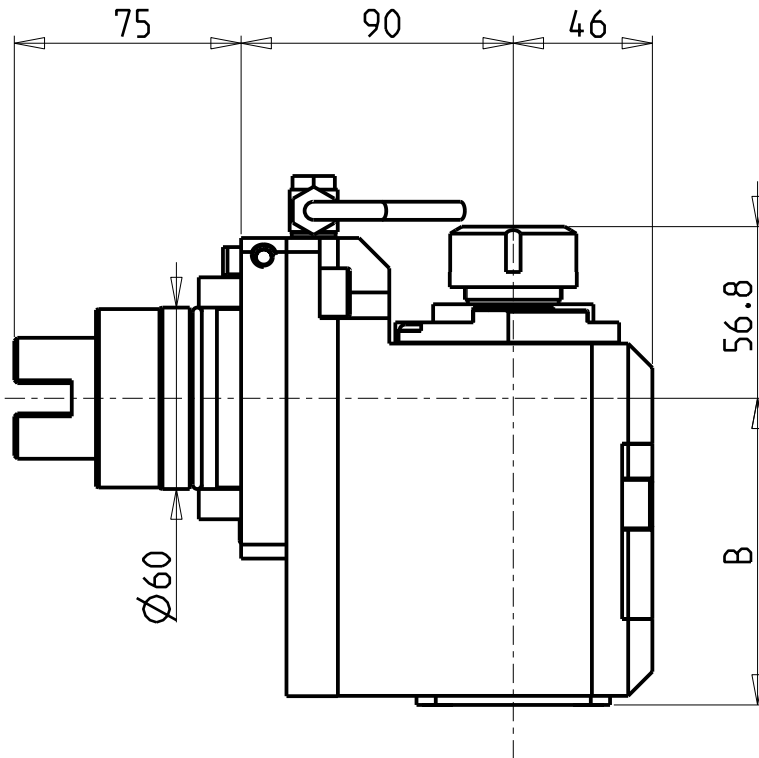

- Chiave inclusa
- Key included
- Schlüssel inbegriffen

Cod. MT	Mandrino Spindle Spindel	I	RPM	Coppia Max Max Torque Max Drehmoment	Lubrificazione int. Coolant through Innenkuehlung	Lubrificazione est. Ext. coolant Aussenkuehlung	B	CHIAVI NON INCLUSE Keys not included Schlüssel nicht einbegriffen	
TKW 0740125	ER25	1:1	6000	50Nm	-	X	101.4	CHSTER25	OKU0650004 •
TKW 0740225	ER25	1:1	6000	50Nm	P=70bar	X	113.9	CHSTER25	OKU0650004 •

NEW
NEW

TAKISAWA
 MOD: EX308/310/508/510/708/710/910 - TC350MC - NEX108/110/908/910 M - LA200M/250M - LA250YS 15ST. - FX-800
 MX-800

MODULO MOTORIZZATO ASSIALE ARRETRATO
 Axial rear-set driven tool
 Axial angetriebenes Werkzeug zurueckversetzt

Subject to change without notice.

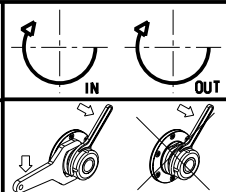

M.T. srl
 Via Casino Albini 480
 Tel. 0541/956034-957884
 Fax 0541/956341
 47842 S. GIOVANNI IN M. (RN)
 e-mail: mtma@mtmarchetti.com
 http://www.mtmarchetti.com

PRODUZIONE MODULI ROTANTI



PAGINA TKW 180-2-10

ATTENZIONE - ATTENTION - ACHTUNG

- VERIFICARE LE MISURE DI INGOMBRO PER POSSIBILE INTERFERENZA SU ALCUNI MODELLI DI MACCHINE
- Please check the overall sizes for possible interferences on some machine models
- Bitte überprüfen sie das ausmass um mögliche interferenzen auf einigen maschinen modellen zu vermeiden

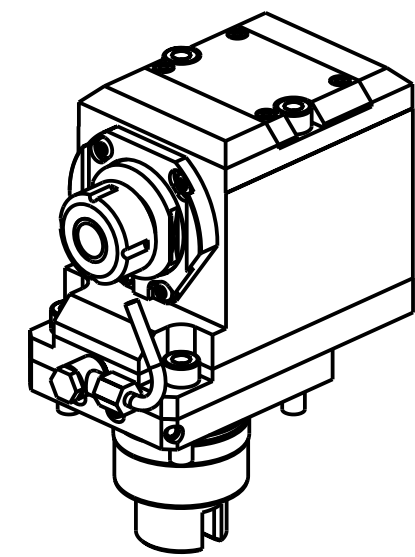
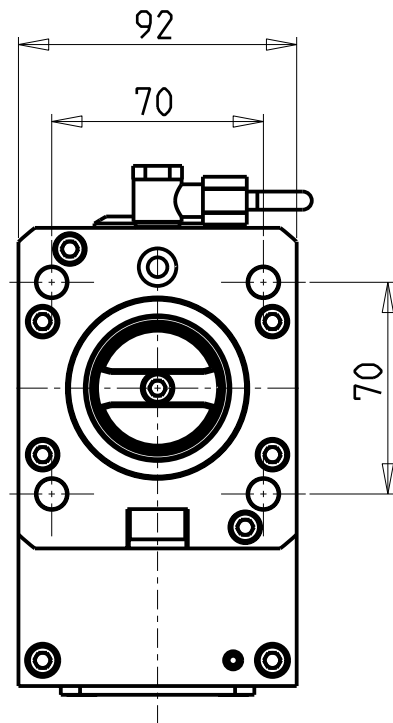
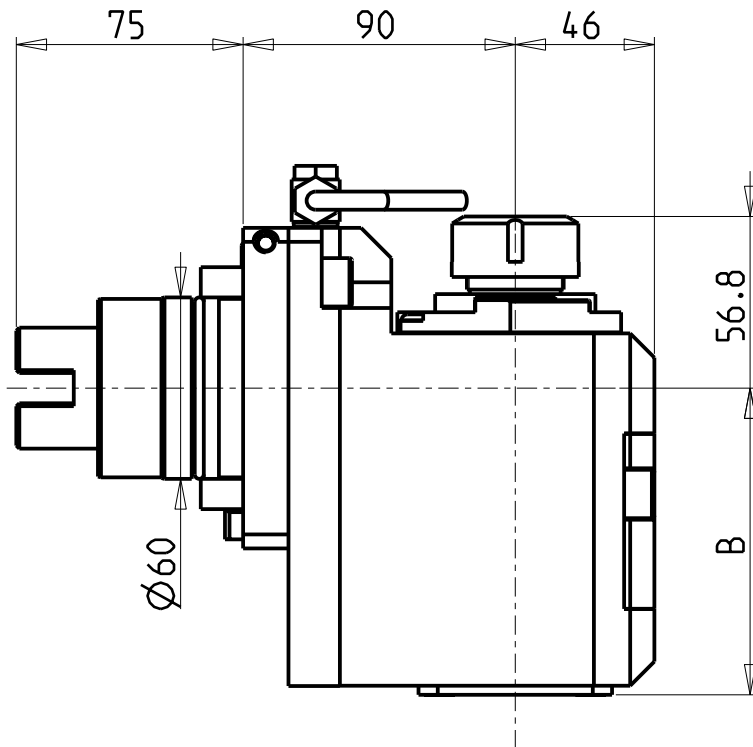

Cod. MT	Mandrino Spindle Spindel	I	RPM	Coppia Max Max Torque Max Drehmoment	Lubrificazione int. Coolant through Innenkuehlung	Lubrificazione est. Ext. coolant Aussenkuehlung	B	CHIAVI NON INCLUSE Keys not included Schluessel nicht einbegriffen	
TKW 074.1125	ER25	1:1	6000	50Nm	-	X	101.4	CHSTER25	OKU0650004 •
TKW 074.1225	ER25	1:1	6000	50Nm	P=70bar	X	113.9	CHSTER25	OKU0650004 •

- Chiave inclusa
- Key included
- Schluessel inbegriffen

NEW
NEW

TAKISAWA
 MOD: EX308/310/508/510/708/710/910 - TT350 MC - NEX908/910 - LA250YS 15ST. - FX-800 - MX-800

MODULO MOTORIZZATO ASSIALE ARRETRATO PER CONTROMANDRINO
 Axial rear-set driven tool for subspindle
 Axial angetriebenes Werkzeug fuer Gegenspindel zurueckversetzt

Subject to change without notice.

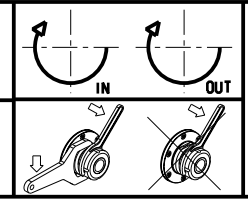

M.T. srl
 Via Casino Albini 480
 Tel. 0541/956034-957884
 Fax 0541/956341
 47842 S. GIOVANNI IN M. (RN)
 e-mail: mtma@mtmarchetti.com
 http://www.mtmarchetti.com

PRODUZIONE MODULI ROTANTI



PAGINA TKW 185-2-10

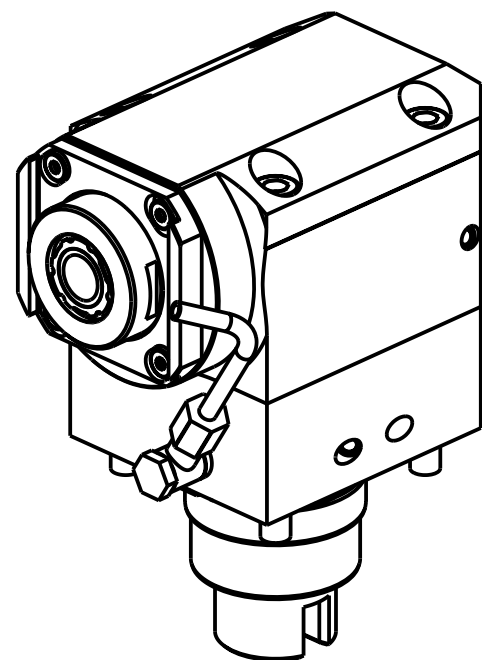
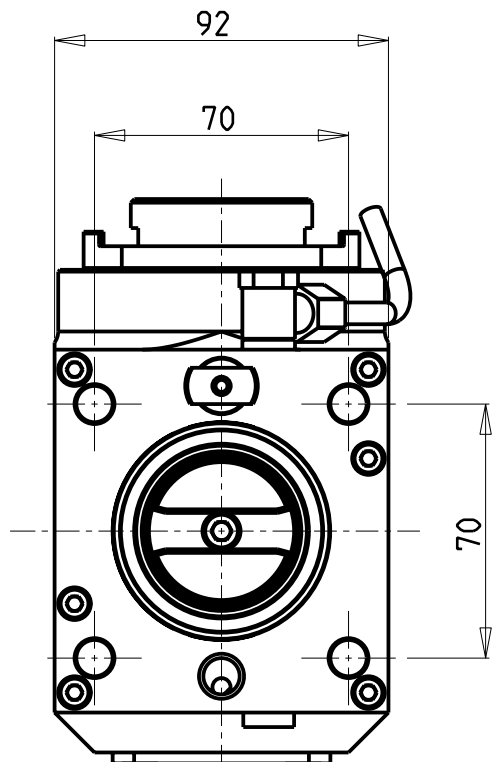
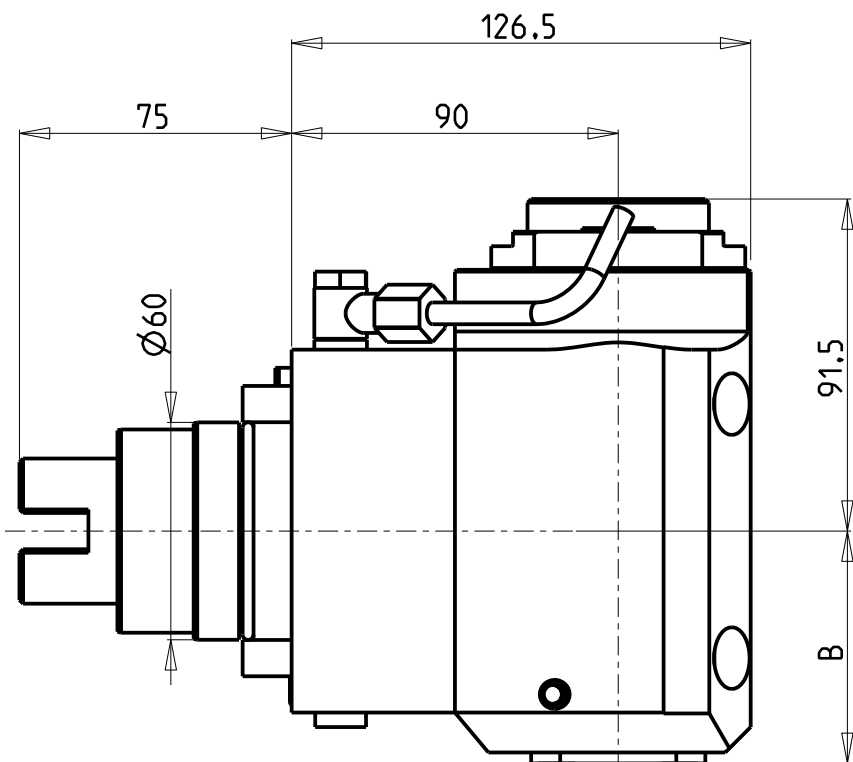

- Chiave inclusa
- Key included
- Schlüssel inbegriffen

Cod. MT	Mandrino Spindle Spindel	I	RPM	Coppia Max Max Torque Max Drehmoment	Lubrificazione int. Coolant through Innenkuehlung	Lubrificazione est. Ext. coolant Aussenkuehlung	B	CHIAVI NON INCLUSE Keys not included Schlüssel nicht einbegriffen		
TKW 0440325	ERA25	1:2	12000	30Nm	-	X	64	CHUB27	CHTAER25ZC	OKU0650004
TKW 0440425	ERA25	1:2	12000	30Nm	P=70bar	X	74	CHUB27	CHTAER25ZC	OKU0650004

TAKISAWA

MOD: EX308/310/508/510/708/710/910 - TC350MC - TT350 MC - NEX108/110/908/910 M - LA200M/250M - LA250YS 15ST.
FX-800 - MX-800 - VTL450M

MODULO MOTORIZZATO ASSIALE MOLTIPLICATO I=1:2

Axial geared-up I=1:2 driven tool

Axial angetriebenes Werkzeug uebersetzt I=1:2

Subject to change without notice.

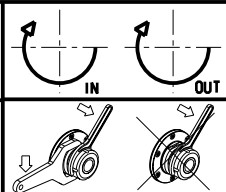

M.T. srl

Via Casino Albini 480
Tel. 0541/956034-957884
Fax 0541/956341
47842 S. GIOVANNI IN M. (RN)
e-mail: mtma@mtmarchetti.com
http://www.mtmarchetti.com

PRODUZIONE MODULI ROTANTI



PAGINA TKW 200-2-10

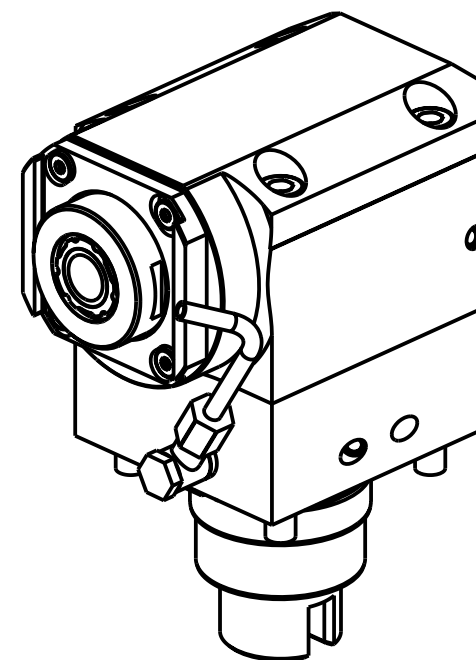
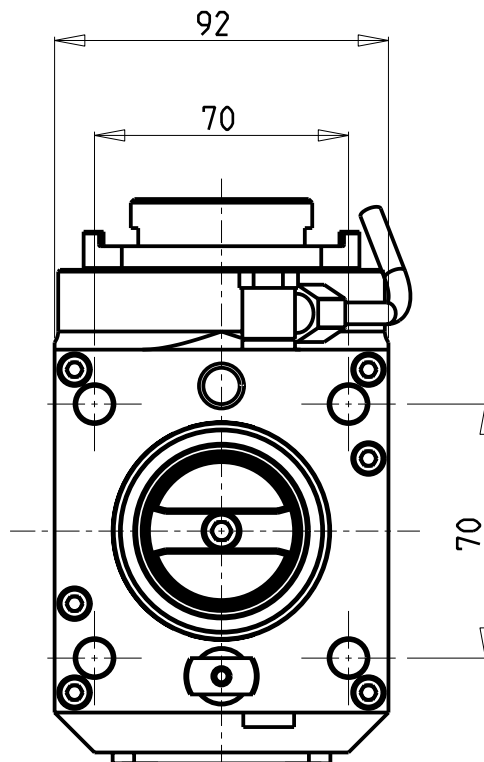
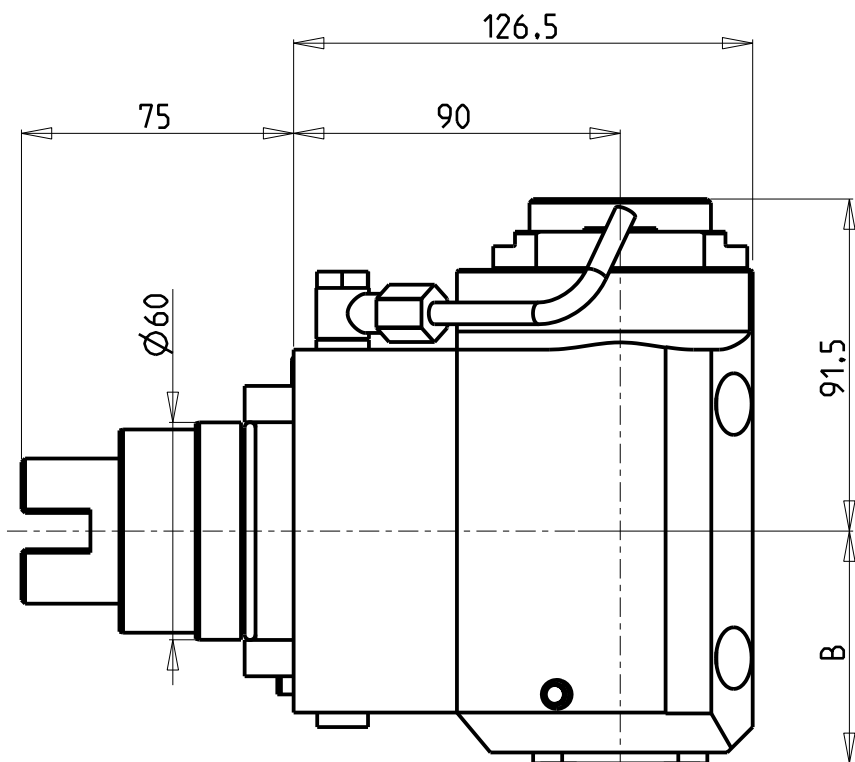

Cod. MT	Mandrino Spindle Spindel	I	RPM	Coppia Max Max Torque Max Drehmoment	Lubrificazione int. Coolant through Innenkuehlung	Lubrificazione est. Ext. coolant Aussenkuehlung	B	CHIAVI NON INCLUSE Keys not included Schluessel nicht einbegriffen		
TKW 0440525	ERA25	1:2	12000	30Nm	-	X	64	CHUB27	CHTAER25ZC	OKU0650004
TKW 0440625	ERA25	1:2	12000	30Nm	P=70bar	X	74	CHUB27	CHTAER25ZC	OKU0650004

- Chiave inclusa
- Key included
- Schluessel inbegriffen

TAKISAWA

MOD: EX308/310/508/510/708/710/910 - TT350 MC - NEX908/910 - LA250YS 15ST. - FX-800 - MX-800

MODULO MOTORIZZATO ASSIALE MOLTIPLICATO I=1:2 PER CONTROMANDRINO

Axial geared-up I=1:2 driven tool for subspindle

Axial angetriebenes Werkzeug uebersetzt I=1:2 fuer Gegenspindel

Subject to change without notice.

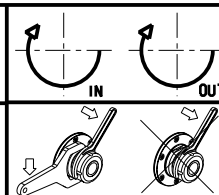

M.T. srl
 Via Casino Albini 480
 Tel. 0541/956034-957884
 Fax 0541/956341
 47842 S. GIOVANNI IN M. (RN)
 e-mail: mtma@mtmarchetti.com
 http://www.mtmarchetti.com

PRODUZIONE MODULI ROTANTI



PAGINA TKW 200-2-11

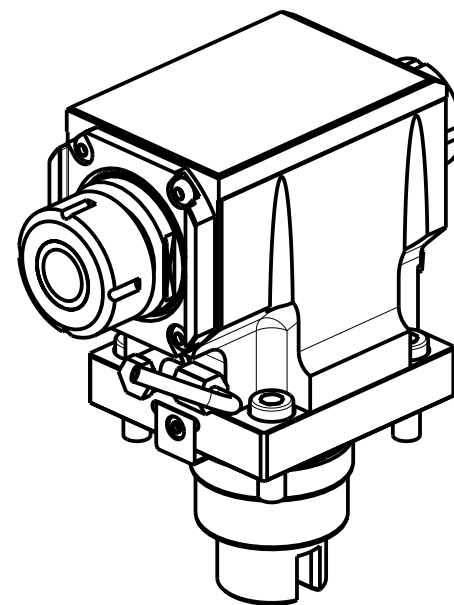
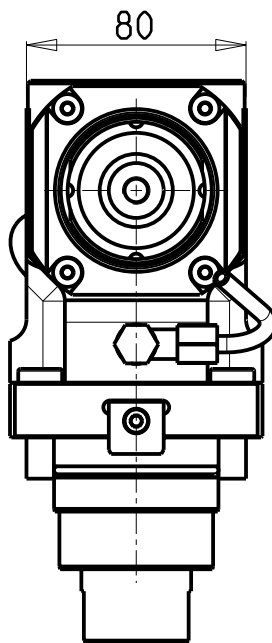
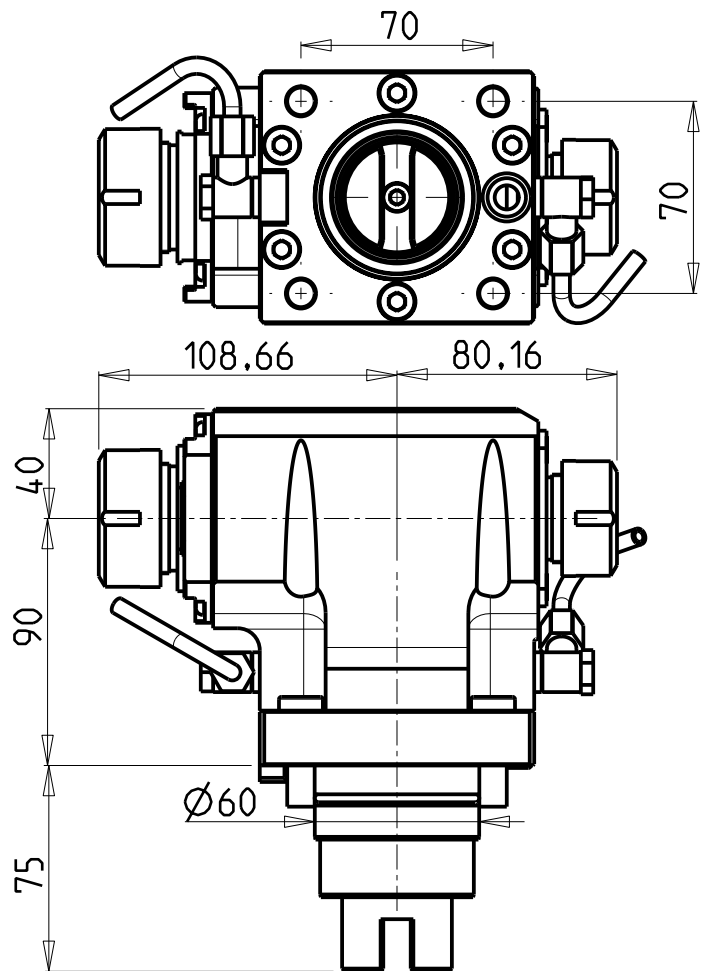

ATTENZIONE - ATTENTION - ACHTUNG

- Per lo smontaggio degli utensili utilizzare sempre la chiave di contrasto come indicato nel manuale d'uso.
- For disassembly of the tools use always the contrast key as mentioned in the user instructions.
- Fuer das Abmontieren der Werkzeuge immer den Gegenschlüssel benutzen wie in der Bedienungsanleitung erwaeht.

- Chiave inclusa
- Key included
- Schluessel inbegriffen

Cod. MT	Mandrino Spindle Spindel	I	RPM	Coppia Max Max Torque Max Drehmoment	Lubr.esterna Ext. coolant Aussenkuehlung	CHIAVI NON INCLUSE Keys not included Schluessel nicht einbegriffen		
TKW 0130132	ER32+ER25	1:1	6000	65Nm	X	CHSTER32	CHSTER25	OKU0650004 *

TAKISAWA

MOD: EX308/310/508/510/708/710/910 - TT350 MC - NEX908/910 - LA250YS 15ST. - FX-800 - MX-800

MODULO MOTORIZZATO ASSIALE BISPORGENTE
Axial opposite face twin driven tool
Axial angetriebenes Werkzeug halb vorspringend

Subject to change without notice.

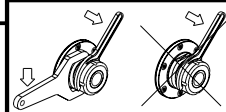

M.T. srl

Via Casino Albini 480
Tel. 0541/956034-957884
Fax 0541/956341
47842 S. GIOVANNI IN M. (RN)
e-mail: mtma@mtmarchetti.com
http://www.mtmarchetti.com

PRODUZIONE MODULI ROTANTI



PAGINA TKW 240-2-10

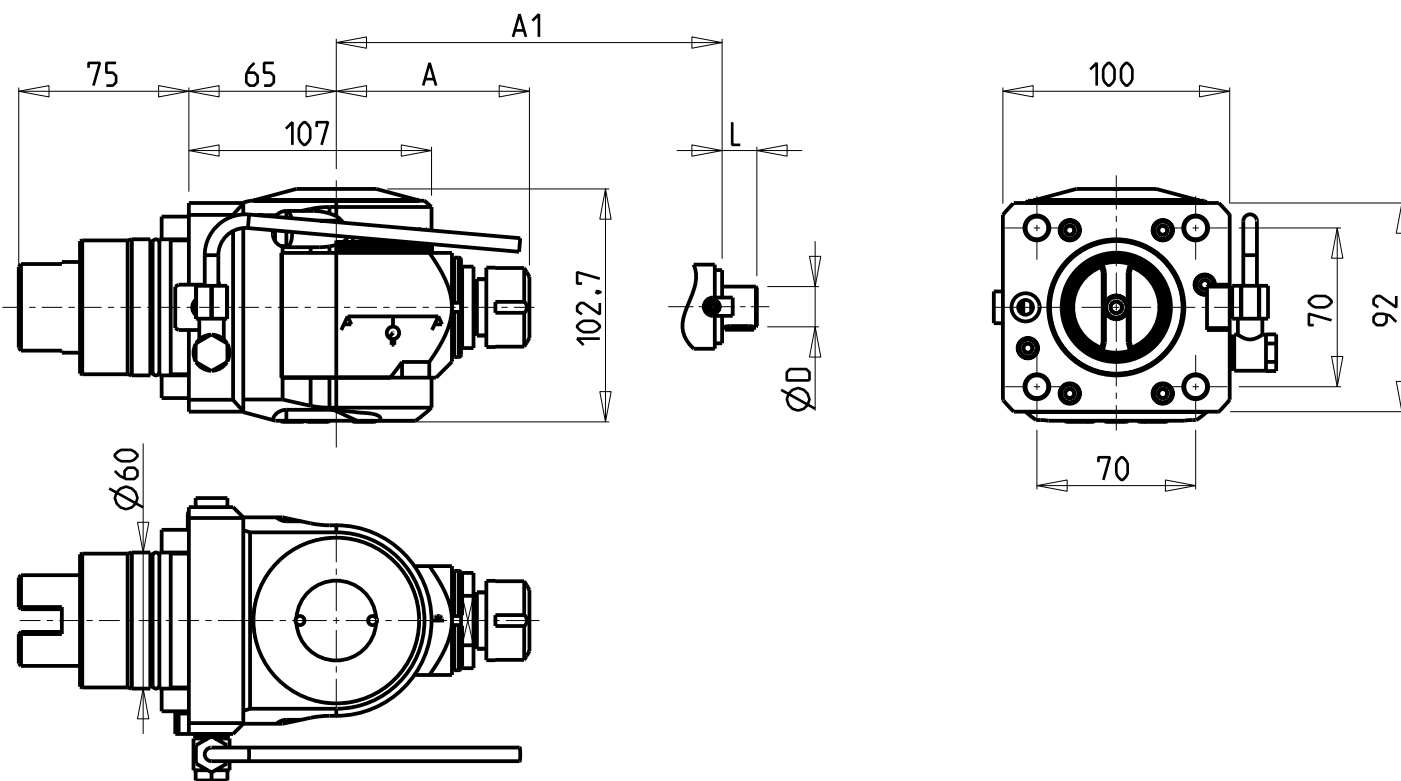

ATTENZIONE - ATTENTION - ACHTUNG

- VERIFICARE LE MISURE DI INGOMBRO PER POSSIBILE INTERFERENZA SU ALCUNI MODELLI DI MACCHINE
- Please check the overall sizes for possible interferences on some machine models
- Bitte überprüfen sie das ausmass um mögliche interferenzen auf einigen maschinen modellen zu vermeiden

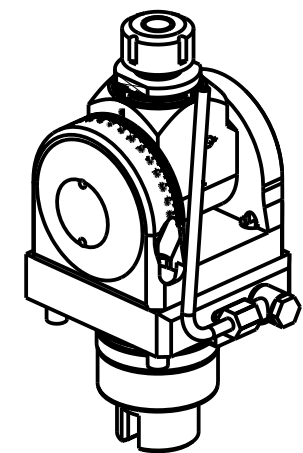

Cod. MT	Mandrino Spindle Spindel	I	RPM	Coppia Max Max Torque Max Drehmoment	Reversibile lato mandrino/contromandrino Reversible sub/main spindle side Umkehrbare Spindel-seite/ Gegenspindel-seite	Lubrificazione est. Ext. coolant Aussenkuehlung	A	A1	D	L	CHIAVI INCLUSE Keys included Schluessel inbegriffen			
											CHSTER	CHUB36	CHESLO8	
TKW 0710120	ER20	1:1	6000	40Nm	X	X	85.16	-	-	-	CHSTER20	CHUB36	CHESLO8	NEW
TKW 0710125	ER25	1:1	6000	40Nm	X	X	86.16	-	-	-	CHSTER25	CHUB36	CHESLO8	NEW
TKW 0710516	Ø16x17	1:1	6000	40Nm	X	X	-	65	16	17	CH_VTCROCE_M08	CHUB36	CHESLO8	NEW
TKW 0710522	Ø22x19	1:1	6000	40Nm	X	X	-	66	22	19	CH_VTCROCE_M10	CHUB36	CHESLO8	NEW
TKW 0710519	Ø3/4"x3/4"	1:1	6000	40Nm	X	X	-	65	3/4"	3/4"	CH_VTCROCE_M08	CHUB36	CHESLO8	NEW

TAKISAWA MOD: EX308/310/508/510/708/710/910 - TC350MC - TT350 MC - NEX108/110/908/910 M - LA200M/250M - LA250YS 15ST. FX-800 - MX-800 - VTL450M		M.T. srl Via Casino Albini 480 Tel. 0541/956034-957884 Fax 0541/956341 47842 S. GIOVANNI IN M. (RN) e-mail: mtma@mtmarchetti.com http://www.mtmarchetti.com	PRODUZIONE MODULI ROTANTI
	MODULO MOTORIZZATO ORIENTABILE ±90° H=65mm ±90° adjustable angle driven tool H=65mm Angetriebenes Werkzeug schwenkbar ±90° H=65mm		

Subject to change without notice.

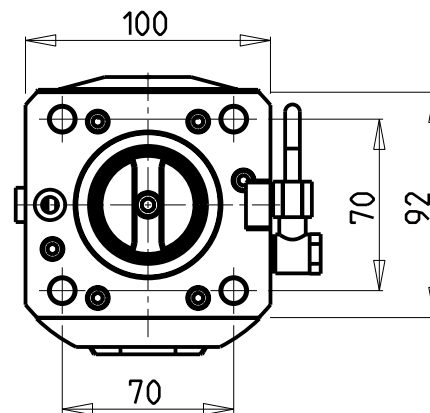
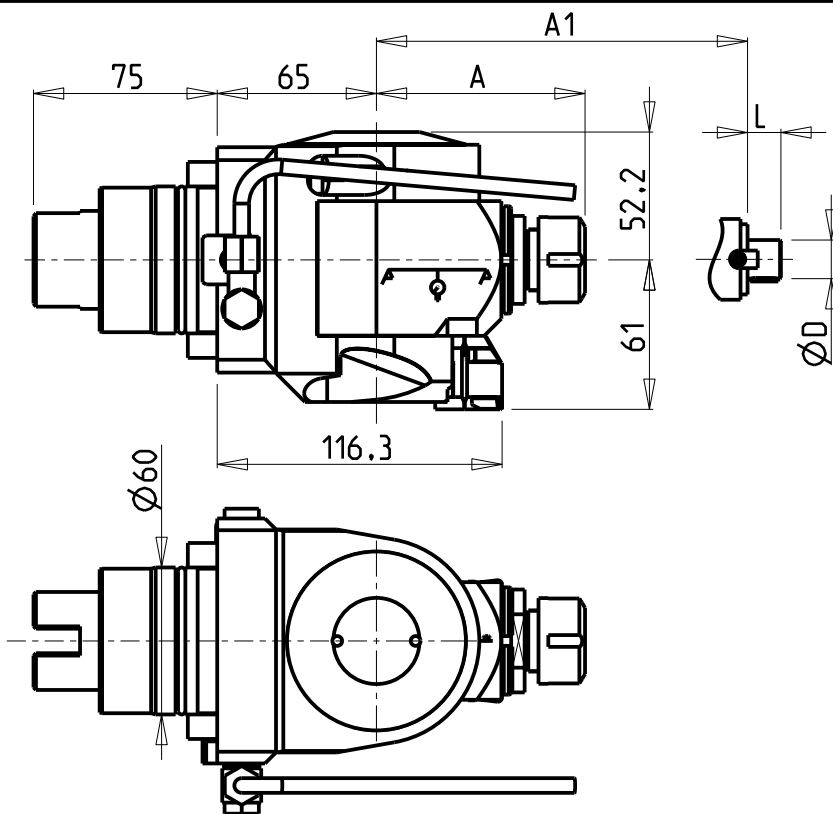

ATTENZIONE - ATTENTION - ACHTUNG

- VERIFICARE LE MISURE DI INGOMBRO PER POSSIBILE INTERFERENZA SU ALCUNI MODELLI DI MACCHINE
- Please check the overall sizes for possible interferences on some machine models
- Bitte überprüfen sie das ausmass um mögliche interferenzen auf einigen maschinen modellen zu vermeiden

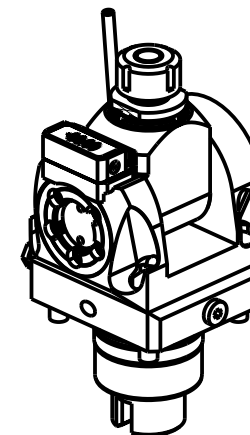

Cod. MT	Mandrino Spindle Spindel	I	RPM	Coppia Max Max Torque Max Drehmoment	Reversibile lato mandrino/contromandrino Reversible sub/main spindle side Umkehrbare Spindel-seite/ Gegenspindel-seite	Lubrificazione est. Ext. coolant Aus-senkuehlung	A	A1	D	L	CHIAVI INCLUSE Keys included Schluessel inbegriffen			
TKW 0720120	ER20	1:1	6000	40Nm	X	X	85.16	-	-	-	CHSTER20	CHUB36	CHESL08	NEW
TKW 0720125	ER25	1:1	6000	40Nm	X	X	86.16	-	-	-	CHSTER25	CHUB36	CHESL08	NEW
TKW 0720516	Ø16x17	1:1	6000	40Nm	X	X	-	65	16	17	CH_VTCROCE_M08	CHUB36	CHESL08	NEW
TKW 0720522	Ø22x19	1:1	6000	40Nm	X	X	-	66	22	19	CH_VTCROCE_M10	CHUB36	CHESL08	NEW
TKW 0720519	Ø3/4"x3/4"	1:1	6000	40Nm	X	X	-	65	3/4"	3/4"	CH_VTCROCE_M08	CHUB36	CHESL08	NEW

TAKISAWA

MOD: EX308/310/508/510/708/710/910 - TC350MC - TT350 MC - NEX108/110/908/910 M - LA200M/250M - LA250YS 15ST.
FX-800 - MX-800 - VTL450M

MODULO MOTORIZZATO ORIENTABILE ±90° CON NONIO DIGITALE H=65mm
±90° adjustable angle driven tool with digital display H=65mm
Angetriebenes Werkzeug schwenkbar ±90° mit digital display H=65mm

Subject to change without notice.

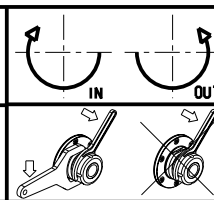

M.T. srl

Via Casino Albini 480
Tel. 0541/956034-957884
Fax 0541/956341
47842 S. GIOVANNI IN M. (RN)
e-mail: mtma@mtmarchetti.com
http://www.mtmarchetti.com

PRODUZIONE MODULI ROTANTI



PAGINA TKW 333-2-01

