

		PAGINA Page Seite
MODULO MOTORIZZATO RADIALE VDI40 Radial driven tool VDI40 Radial angetriebenes Werkzeug VDI40		TAK010.1.00
MODULO MOTORIZZATO ASSIALE ARRETRATO PER MANDRINO VDI40 Axial rear-set driven tool for main spindle VDI40 Axial angetriebenes Werkzeug fuer Hauptspindel-seite zurueckversetzt VDI40		TAK180.1.10
MODULO MOTOR. ASSIALE ARRETRATO PER CONTROMANDRINO VDI40 Axial rear-set driven tool for sub spindle VDI40 Axial angetriebenes Werkzeug fuer Gegenspindel-seite zurueckversetzt VDI40		TAK185.1.10

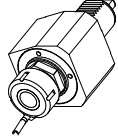
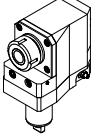
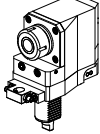
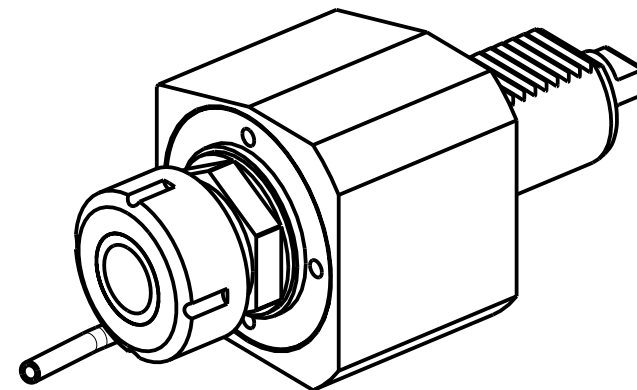
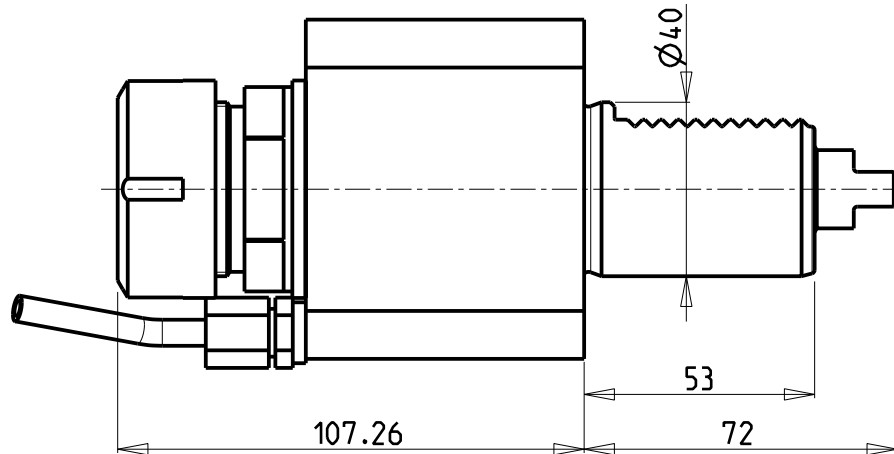
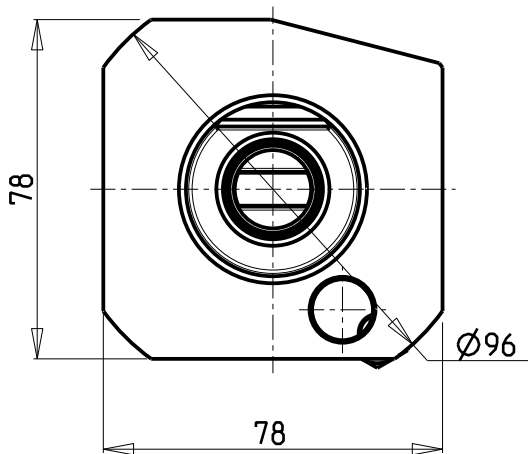

Cod. MT	Mandrino Spindle Spindel	I	RPM	Coppia Max Max Torque Max Drehmoment	Lubrificazione est. Ext. coolant Aussenkuehlung	CHIAVI NON INCLUSE Keys not included Schluessel nicht einbegriffen	
223TAK_R32_40A00	ER32	1:1	4000	70Nm	X	CHUB41	CHSTER32

TAKAMAZ
VDI 40

MODULO MOTORIZZATO RADIALE VDI40
Radial driven tool VDI40
Radial angetriebenes Werkzeug VDI40

Subject to change without notice.

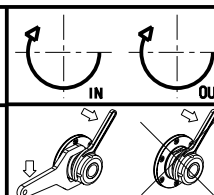

M.T. srl
Via Casino Albini 480
Tel. 0541/956034-957884
Fax 0541/956341
47842 S. GIOVANNI IN M. (RN)
e-mail: mtma@mtmarchetti.com
http://www.mtmarchetti.com

PRODUZIONE MODULI ROTANTI



PAGINA TAK010-1-00

ATTENZIONE - ATTENTION - ACHTUNG

- Per lo smontaggio degli utensili utilizzare sempre la chiave di contrasto come indicato nel manuale d'uso.
- For disassembly of the tools use always the contrast key as mentioned in the user instructions.
- Fuer das Abmontieren der Werkzeuge immer den Gegenschlüssel benutzen wie in der Bedienungsanleitung erwaeht.

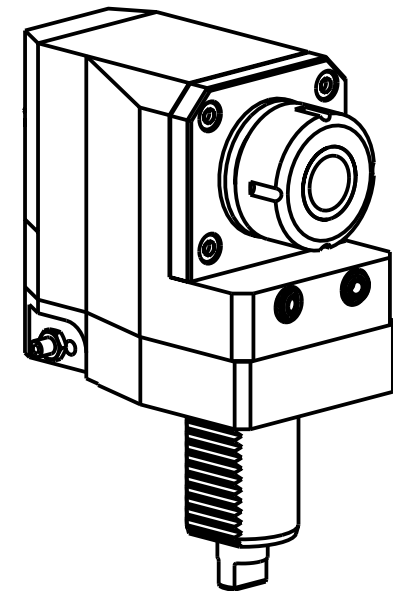
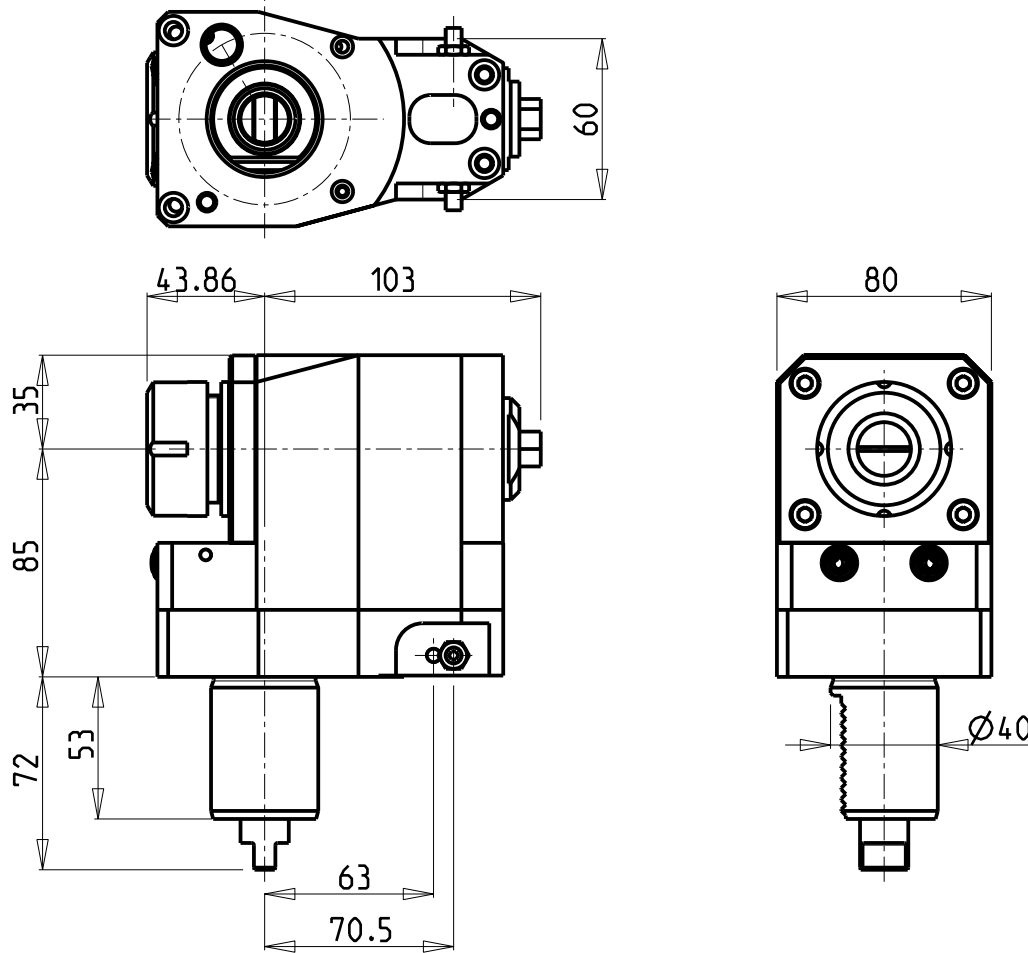

Cod. MT	Mandrino Spindle Spindel	I	RPM	Coppia Max Max Torque Max Drehmoment	Lubrificazione est. Ext. coolant Aussenkuehlung	CHIAVI NON INCLUSE Keys not included Schluessel nicht einbegriffen	
221TAK_A32_40A00	ER32	1:1	4000	70Nm	X	CHUB13	CHSTER32

TAKAMAZ
VDI 40

MODULO MOTORIZZATO ASSIALE ARRETRATO PER MANDRINO VDI40
Axial rear-set driven tool for main spindle VDI40
Axial angetriebenes Werkzeug fuer Hauptspindel-seite zurueckversetzt VDI40

Subject to change without notice.

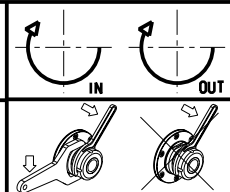

M.T. srl
Via Casino Albini 480
Tel. 0541/956034-957884
Fax 0541/956341
47842 S. GIOVANNI IN M. (RN)
e-mail: mtma@mtmarchetti.com
http://www.mtmarchetti.com

PRODUZIONE MODULI ROTANTI



PAGINA TAK180-1-10

ATTENZIONE - ATTENTION - ACHTUNG

- Per lo smontaggio degli utensili utilizzare sempre la chiave di contrasto come indicato nel manuale d'uso.
- For disassembly of the tools use always the contrast key as mentioned in the user instructions.
- Fuer das Abmontieren der Werkzeuge immer den Gegenschlüssel benutzen wie in der Bedienungsanleitung erwaeht.

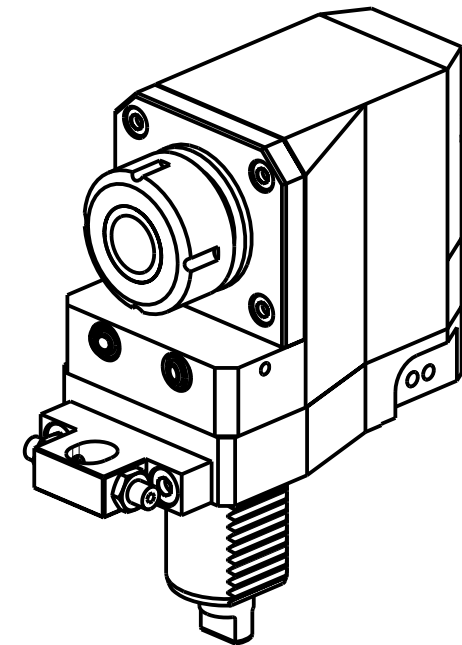
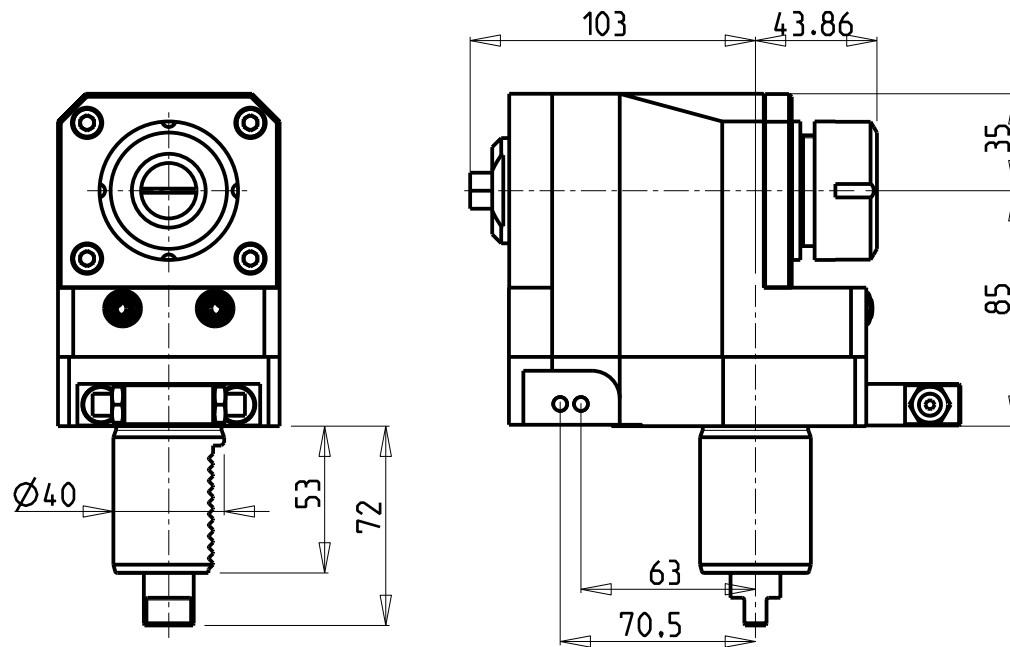
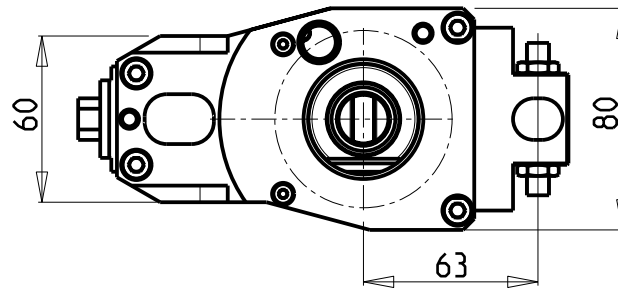

Cod. MT	Mandrino Spindle Spindel	I	RPM	Coppia Max Max Torque Max Drehmoment	Lubrificazione est. Ext. coolant Aussenkuehlung	CHIAVI NON INCLUSE Keys not included Schluessel nicht einbegriffen	
222TAK_A32_40A00	ER32	1:1	4000	70Nm	X	CHUB13	CHSTER32

TAKAMAZ
VDI 40

MODULO MOTORIZZATO ASSIALE ARRETRATO PER CONTROMANDRINO VDI40

Axial rear-set driven tool for sub spindle VDI40

Axial angetriebenes Werkzeug fuer Gegenspindel-seite zurueckversetzt VDI40

Subject to change without notice.

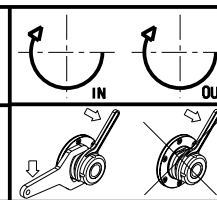

M.T. srl

Via Casino Albini 480
Tel. 0541/956034-957884
Fax 0541/956341
47842 S. GIOVANNI IN M. (RN)
e-mail: mtma@mtmarchetti.com
http://www.mtmarchetti.com

PRODUZIONE MODULI ROTANTI



PAGINA TAK185-1-10

