

**TORRETTE ASSIALI  
AXIAL TURRETS  
AXIAL REVOLVER**

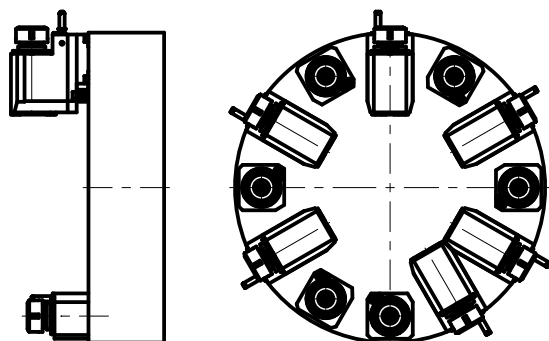

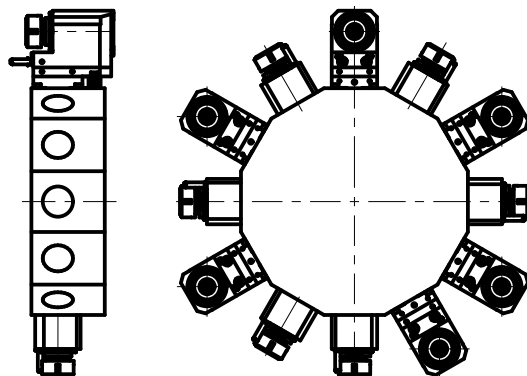



**TORRETTE RADIALI  
RADIAL TURRETS  
RADIAL REVOLVER**

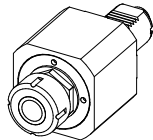
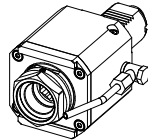
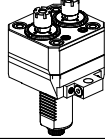
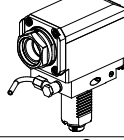

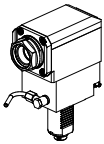
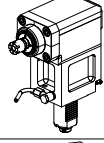
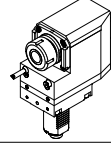
<b>MACCHINE MACHINES MASCHINEN</b>	<b>MODELLI MODELS MODELLE</b>
<b>BOEHRINGER</b>	NG 180/200 - NV 250 - 16 M
<b>COLCHESTER</b>	T 8 MS/MSY
<b>DOOSAN</b>	H 310 - S 390 M - S 550 - Z 280
<b>EMCO</b>	ET 500 - Hyperturn 645/665/690 MC - Maxxturn 65
<b>FMS</b>	M 35 G - NDM 20
<b>GILDEMEISTER</b>	Beta 500/800/1250 - CTX 410/420/450/510/520 - CTV 200/250 - Gamma 1250/2000 GMX 250/300/400 - MF Twin 42/65 - NEF 600 - Twin 42/65/102 - Sprint 65
<b>GRAZIANO</b>	GT 500 G
<b>HURCO</b>	TMM 10
<b>MAGDEBURGER</b>	M 160 - MV 160
<b>MONFORTS</b>	DNC 5/500
<b>NILES</b>	NF 13/16/20 - NV 20
<b>SHAUBLIN</b>	42 L TM/TMI - 65 TM/TM-3Y/TMI
<b>SCHERER FEINBAU</b>	VDZ 120/320/400 - WDZ 250 G
<b>SCHMID</b>	DZ 5
<b>VICTOR</b>	VT II 23/26 - VT A26 SCV/YSCV
<b>VIPER</b>	VT 2300 YMS
<b>WEISSER</b>	Univertor AD/AS/M
<b>WFL</b>	M 30

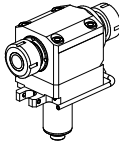
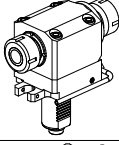
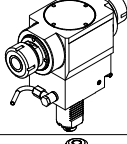
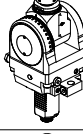
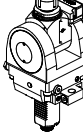
		PAGINA Page Seite
<p><b>MODULO MOTORIZZATO ASSIALE VDI40 DIN 5480</b> Axial driven tool VDI40 DIN 5480 Axial angetriebenes Werkzeug VDI40 DIN 5480</p>		SAU017.3.00
<p><b>MODULO MOTORIZZATO ASSIALE MTSK VDI40 DIN 5480</b> Axial MTSK driven tool VDI40 DIN 5480 Axial MTSK angetriebenes Werkzeug VDI40 DIN 5480</p>		SAU017.3.00.K
<p><b>MODULO MOTORIZZATO ASSIALE DISASSATO 60mm VDI40 DIN 5480</b> Axial driven tool re-directed by 60mm VDI40 DIN 5480 Axial angetriebenes Werkzeug achsversetzt um 60mm VDI40 DIN 5480</p>		SAU017.3.05
<p><b>MODULO MOTOR. ASSIALE RIDOTTO I=2:1 DISASSATO 60mm VDI40 DIN 5480</b> Axial geared-down I=2:1 driven tool re-directed by 60mm VDI40 DIN 5480 Axial angetriebenes Werkzeug untersetzt I=2:1 achsversetzt um 60mm VDI40 DIN 5480</p>		SAU017.3.30
<p><b>MODULO MOTOR. ASSIALE RIDOTTO I=3:1 DISASSATO 60mm VDI40 DIN 5480</b> Axial geared-down I=3:1 driven tool re-directed by 60mm VDI40 DIN 5480 Axial angetriebenes Werkzeug untersetzt I=3:1 achsversetzt um 60mm VDI40 DIN 5480</p>		SAU017.3.40
<p><b>MODULO MOTOR. ASSIALE MOLTIPLICATO I=1:2 DISASSATO 60mm VDI40 DIN 5480</b> Axial geared-up I=1:2 driven tool re-directed by 60mm VDI40 DIN 5480 Axial angetriebenes Werkzeug uebersetzt I=1:2 achsversetzt um 60mm VDI40 DIN 5480</p>		SAU017.3.60
<p><b>MODULO MOTOR. ASSIALE MOLTIPLICATO I=1:2 DISASSATO 42mm VDI40 DIN 5480</b> Axial geared-up I=1:2 driven tool re-directed by 42mm VDI40 DIN 5480 Axial angetriebenes Werkzeug uebersetzt I=1:2 achsversetzt um 42mm VDI40 DIN 5480</p>		SAU017.3.61
<p><b>MODULO MOTORIZZATO ASSIALE 2 USCITE IN Y VDI40 DIN 5480</b> Axial single side twin head driven tool in Y VDI40 DIN 5480 Axial angetriebenes Werkzeug 2 Ausgaenge in Y VDI40 DIN 5480</p>		SAU017.3.80
<p><b>MODULO MOTORIZZATO RADIALE VDI40 DIN 5480 H=70mm</b> Radial driven tool VDI40 DIN 5480 H=70mm Radial angetriebenes Werkzeug VDI40 DIN 5480 H=70mm</p>		SAU018.3.00
<p><b>MODULO MOTORIZZATO RADIALE MTSK VDI40 DIN 5480 H=70mm</b> Radial MTSK driven tool VDI40 DIN 5480 H=70mm Radial MTSK angetriebenes Werkzeug VDI40 DIN 5480 H=70mm</p>		SAU018.3.00.K
<p><b>MODULO MOTOR. RADIALE MOLTIPLICATO I=1:3 VDI40 DIN 5480 H=70mm</b> Radial geared-up I=1:3 driven tool VDI40 DIN 5480 H=70mm Radial angetriebenes Werkzeug uebersetzt I=1:3 VDI40 DIN 5480 H=70mm</p>		SAU018.3.04
<p><b>MODULO MOTORIZZATO RADIALE VDI40 DIN 5480 H=100mm</b> Radial driven tool VDI40 DIN 5480 H=100mm Radial angetriebenes Werkzeug VDI40 DIN 5480 H=100mm</p>		SAU018.3.10

		PAGINA Page Seite
<p><b>MODULO MOTORIZZATO RADIALE MTSK VDI40 DIN 5480 H=100mm</b> Radial MTSK driven tool VDI40 DIN 5480 H=100mm Radial MTSK angetriebenes Werkzeug VDI40 DIN 5480 H=100mm</p>		SAU018.3.10.K
<p><b>MODULO MOTORIZZATO RADIALE MOLTIPLICATO I=1:3 VDI40 DIN 5480</b> Radial geared-up I=1:3 driven tool VDI40 DIN 5480 Radial angetriebenes Werkzeug uebersetzt I=1:3 VDI40 DIN 5480</p>		SAU018.3.14
<p><b>MODULO MOTORIZZATO RADIALE VDI40 DIN 5480 H=130mm</b> Radial driven tool VDI40 DIN 5480 H=130mm Radial angetriebenes Werkzeug VDI40 DIN 5480 H=130mm</p>		SAU018.3.20
<p><b>MODULO MOTORIZZATO RADIALE MTSK VDI40 DIN 5480 H=130mm</b> Radial MTSK driven tool VDI40 DIN 5480 H=130mm Radial MTSK angetriebenes Werkzeug VDI40 DIN 5480 H=130mm</p>		SAU018.3.20.K
<p><b>MODULO MOTOR. RADIALE MOLTIPLICATO I=1:3 VDI40 DIN 5480 H=130mm</b> Radial geared-up I=1:3 driven tool VDI40 DIN 5480 H=130mm Radial angetriebenes Werkzeug uebersetzt I=1:3 VDI40 DIN 5480 H=130mm</p>		SAU018.3.24
<p><b>MODULO MOTORIZZATO RADIALE ARRETRATO VDI40 DIN 5480 H=85mm</b> Radial rear-set driven tool VDI40 DIN 5480 H=85mm Radial angetriebenes Werkzeug zurueckversetzt VDI40 DIN 5480 H=85mm</p>		SAU018.3.60
<p><b>MODULO MOTORIZZATO RADIALE ARRETRATO VDI40 DIN 5480 H=100mm</b> Radial rear-set driven tool VDI40 DIN 5480 H=100mm Radial angetriebenes Werkzeug zurueckversetzt VDI40 DIN 5480 H=100mm</p>		SAU018.3.70
<p><b>MODULO MOTORIZZ. RADIALE ARRETRATO MTSK VDI40 DIN 5480 H=100mm</b> Radial MTSK rear-set driven tool VDI40 DIN 5480 H=100mm Radial MTSK angetriebenes Werkzeug zurueckversetzt VDI40 DIN 5480 H=100mm</p>		SAU018.3.70.K
<p><b>MODULO MOTORIZZATO RADIALE ARRETR. RIDOTTO I=2:1 VDI40 DIN 5480</b> Radial geared-down I=2:1 rear-set driven tool VDI40 DIN 5480 Radial angetriebenes Werkzeug zurueckversetzt untersetzt I=2:1 VDI40 DIN 5480</p>		SAU018.3.71
<p><b>MODULO MOTORIZZ. RADIALE ARRETR. MTSK RIDOTTO I=2:1 VDI40 DIN 5480</b> Radial MTSK geared-down I=2:1 rear-set driven tool VDI40 DIN 5480 Radial MTSK angetriebenes Werkzeug zurueckvers. untersetzt I=2:1 VDI40 DIN 5480</p>		SAU018.3.71.K
<p><b>MODULO MOTORIZZ. RADIALE ARRETR. MOLTIPLIC. I=1:2 VDI40 DIN 5480</b> Radial geared-up I=1:2 rear-set driven tool VDI40 DIN 5480 Radial angetriebenes Werkzeug zurueckversetzt uebersetzt I=1:2 VDI40 DIN 5480</p>		SAU018.3.72
<p><b>MODULO MOTORIZZ. RADIALE ARRETR. MTSK MOLTIPLIC. I=1:2 VDI40 DIN 5480</b> Radial MTSK geared-up I=1:2 rear-set driven tool VDI40 DIN 5480 Radial MTSK angetriebenes Werkzeug zurueckvers. uebersetzt I=1:2 VDI40 DIN 5480</p>		SAU018.3.72.K

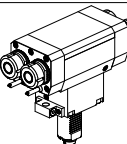
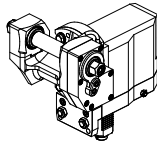
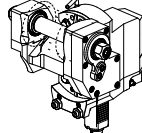
		PAGINA Page Seite
<p><b>MODULO MOTORIZZATO RADIALE BISPORGENTE VDI40 DIN 5480 H=70mm</b> Radial opposite face twin driven tool VDI40 DIN 5480 H=70mm Radial angetriebenes Werkzeug halb vorspringend VDI40 DIN 5480 H=70mm</p>		SAU019.3.00
<p><b>MODULO MOTORIZZATO RADIALE BISPORGENTE VDI40 DIN 5480 H=100mm</b> Radial opposite face twin driven tool VDI40 DIN 5480 H=100mm Radial angetriebenes Werkzeug halb vorspringend VDI40 DIN 5480 H=100mm</p>		SAU019.3.10
<p><b>MODULO MOTORIZ. RADIALE BISPORG. MOLTIPLICATO I=1:2 VDI40 DIN 5480</b> Radial geared-up I=1:2 opposite face twin driven tool VDI40 DIN 5480 Radial angetriebenes Werkzeug halb vorspringend uebersetzt I=1:2 VDI40 DIN 5480</p>		SAU019.3.13
<p><b>MODULO MOTORIZZATO ORIENTABILE ±90° VDI40 DIN 5480</b> ±90° adjustable angle driven tool VDI40 DIN 5480 Angetriebenes Werkzeug schwenkbar ±90° VDI40 DIN 5480</p>		SAU019.3.60
<p><b>MOD. MOTOR. ORIENTABILE ±90° CON NONIO DIGITALE VDI40 DIN 5480</b> ±90° adjustable angle driven tool with digital display VDI40 DIN 5480 Angetriebenes Werkzeug schwenkbar ±90° mit digital display VDI40 DIN 5480</p>		SAU019.3.61
<p><b>MODULO MOTORIZZATO ORIENTABILE ±90° VDI40 DIN 5480</b> ±90° adjustable angle driven tool VDI40 DIN 5480 Angetriebenes Werkzeug schwenkbar ±90° VDI40 DIN 5480</p>		SAU019.3.70
<p><b>MOD. MOTOR. ORIENTABILE ±90° CON NONIO DIGITALE VDI40 DIN 5480</b> ±90° adjustable angle driven tool with digital display VDI40 DIN 5480 Angetriebenes Werkzeug schwenkbar ±90° mit digital display VDI40 DIN 5480</p>		SAU019.3.71
<p><b>MODULO MOTOR. ORIENTABILE ±90° MOLTIPLICATO I=1:2 VDI40 DIN 5480</b> ±90° adjustable angle driven tool geared-up I=1:2 VDI40 DIN 5480 Angetriebenes Werkzeug schwenkbar ±90° uebersetzt I=1:2 VDI40 DIN 5480</p>		SAU019.3.80
<p><b>MOD. MOT. ORIENTABILE ±90° MOLTIPL. I=1:2 CON NONIO DIGITALE VDI40</b> ±90° adjustable angle driven tool geared-up I=1:2 with digital display VDI40 Antrieb. Werkzeug schwenkbar ±90° uebersetzt I=1:2 mit digital display VDI40</p>		SAU019.3.81
<p><b>MODULO MOTORIZZATO RADIALE 2+2 USCITE IN Y VDI40 DIN 5480</b> Radial multiple 2+2 outlet driven tool in Y VDI40 DIN 5480 Radial angetriebenes Mehrspindel-Werkzeug 2+2 Ausgaenge in Y VDI40 DIN 5480</p>		SAU020.3.00
<p><b>MODULO MOTORIZZATO PORTACREATORE VDI40 DIN 5480</b> Driven gear hobber VDI40 DIN 5480 Angetriebenes Zahnradwaelzfraes-Werkzeug VDI40 DIN 5480</p>		SAU340.3.00
<p><b>MODULO MOTORIZZATO PORTACREATORE VDI40 DIN 5480</b> Driven gear hobber VDI40 DIN 5480 Angetriebenes Zahnradwaelzfraes-Werkzeug VDI40 DIN 5480</p>		SAU340.3.01

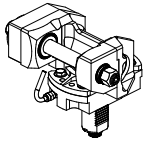
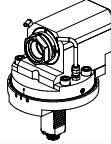
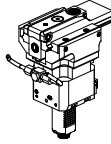
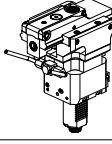
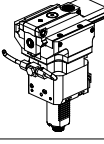
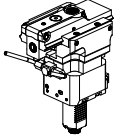
		PAGINA Page Seite
<p><b>MODULO MOTORIZZATO PORTACREATORE VDI40 DIN 5480</b> Driven gear hobber VDI40 DIN 5480 Angetriebenes Zahnradwaelzfraes-Werkzeug VDI40 DIN 5480</p>		SAU340.3.05
<p><b>MOD. MOT. ASSIALE MTSK PER POWER SKIVING H=100mm VDI40 DIN 5480</b> Axial MTSK driven tool for Power Skiving H=100mm VDI40 DIN 5480 Axial MTSK angetriebenes Werkzeug fuer Power Skiving H=100mm VDI40 DIN 5480</p>		SAU350.3.00.K
<p><b>MODULO MOTORIZZ. STOZZATORE CORSA 50mm H=120mm VDI40 DIN 5480</b> Slotting driven tool 50mm stroke H=120mm VDI40 DIN 5480 Keilnutenstossmaschine 50mm Hub H=120mm VDI40 DIN 5480</p>		SAU360.3.00
<p><b>MODULO MOTORIZZ. STOZZATORE CORSA 25mm H=120mm VDI40 DIN 5480</b> Slotting driven tool 25mm stroke H=120mm VDI40 DIN 5480 Keilnutenstossmaschine 25mm Hub H=120mm VDI40 DIN 5480</p>		SAU360.3.01
<p><b>MODULO MOTORIZZ. STOZZATORE CORSA 50mm H=100mm VDI40 DIN 5480</b> Slotting driven tool 50mm stroke H=100mm VDI40 DIN 5480 Keilnutenstossmaschine 50mm Hub H=100mm VDI40 DIN 5480</p>		SAU360.3.10
<p><b>MODULO MOTORIZZ. STOZZATORE CORSA 25mm H=100mm VDI40 DIN 5480</b> Slotting driven tool 25mm stroke H=100mm VDI40 DIN 5480 Keilnutenstossmaschine 25mm Hub H=100mm VDI40 DIN 5480</p>		SAU360.3.11



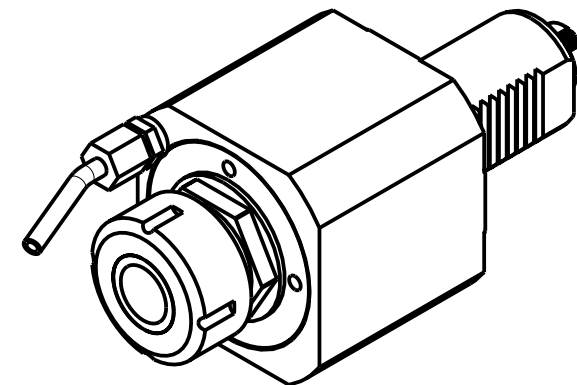
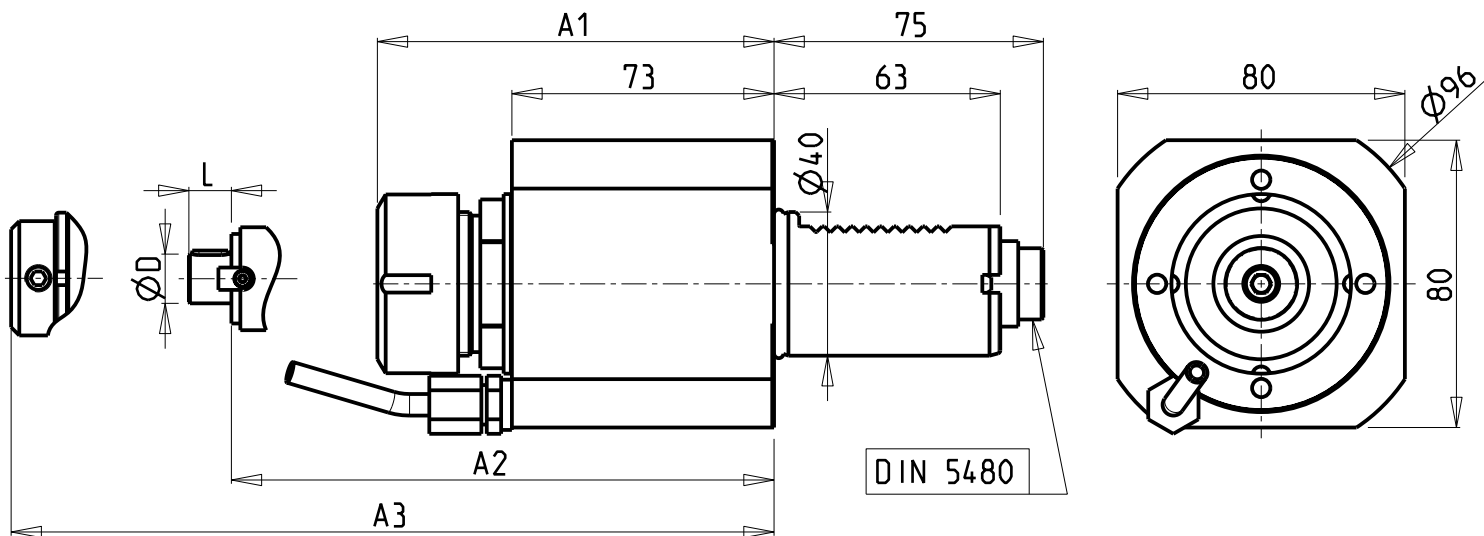

Cod. MT	Mandrino Spindle Spindel	I	RPM	Coppia Max Max Torque Max Drehmoment	Lubrificazione int. Coolant through Innenkuehlung	Lubrificazione est. Ext. coolant Aussenkuehlung	ØD	L	A1	A2	A3	CHIAVI NON INCLUDE Keys not included Schlüssel nicht einbegriffen	
SAU0240140	ER40	1:1	6000	70Nm	-	X	-	-	114	-	-	CHUB41	CHSTER40
212SAU_A32_40D00	ER32	1:1	6000	70Nm	-	X	-	-	110.46	-	-	CHUB41	CHSTER32
212SAU_A32_40D10	ER32	1:1	6000	70Nm	P=30bar	X	-	-	110.46	-	-	CHUB41	CHSTER32
SAU0240125	ER25	1:1	6000	70Nm	-	X	-	-	107.46	-	-	CHUB41	CHSTER25
SAU0241125	ER25	1:1	6000	70Nm	P=30bar	X	-	-	107.46	-	-	CHUB41	CHSTER25
SAU0240320	WELDON20	1:1	6000	70Nm	-	X	-	-	-	-	106.3	-	-
SAU0241320	WELDON20	1:1	6000	70Nm	P=30bar	X	-	-	-	-	106.3	-	-
SAU0240525	WELDON25	1:1	6000	70Nm	-	X	-	-	-	-	106.3	-	-
SAU0241525	WELDON25	1:1	6000	70Nm	P=30bar	X	-	-	-	-	106.3	-	-
SAU0240422	Ø22x19	1:1	6000	70Nm	-	X	22	19	-	96.8	-	CHUB41	CH_VTCROCE_M10 *

- Chiave inclusa
- Key included
- Schlüssel inbegriffen

SAUTER  
VDI 40

MODULO MOTORIZZATO ASSIALE VDI40 DIN 5480  
Axial driven tool VDI40 DIN 5480  
Modul angetriebenes Werkzeug VDI40 DIN 5480

Subject to change without notice.

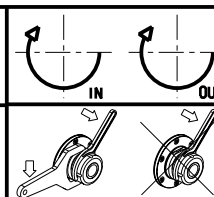

**M.T. srl**  
Via Casino Albini 480  
Tel. 0541/956034-957884  
Fax 0541/956341  
47842 S. GIOVANNI IN M. (RN)  
e-mail: mtma@mtmarchetti.com  
http://www.mtmarchetti.com

PRODUZIONE MODULI ROTANTI



PAGINA SAU017-3-00

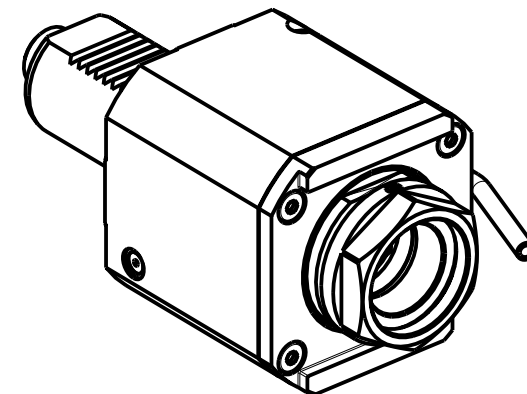
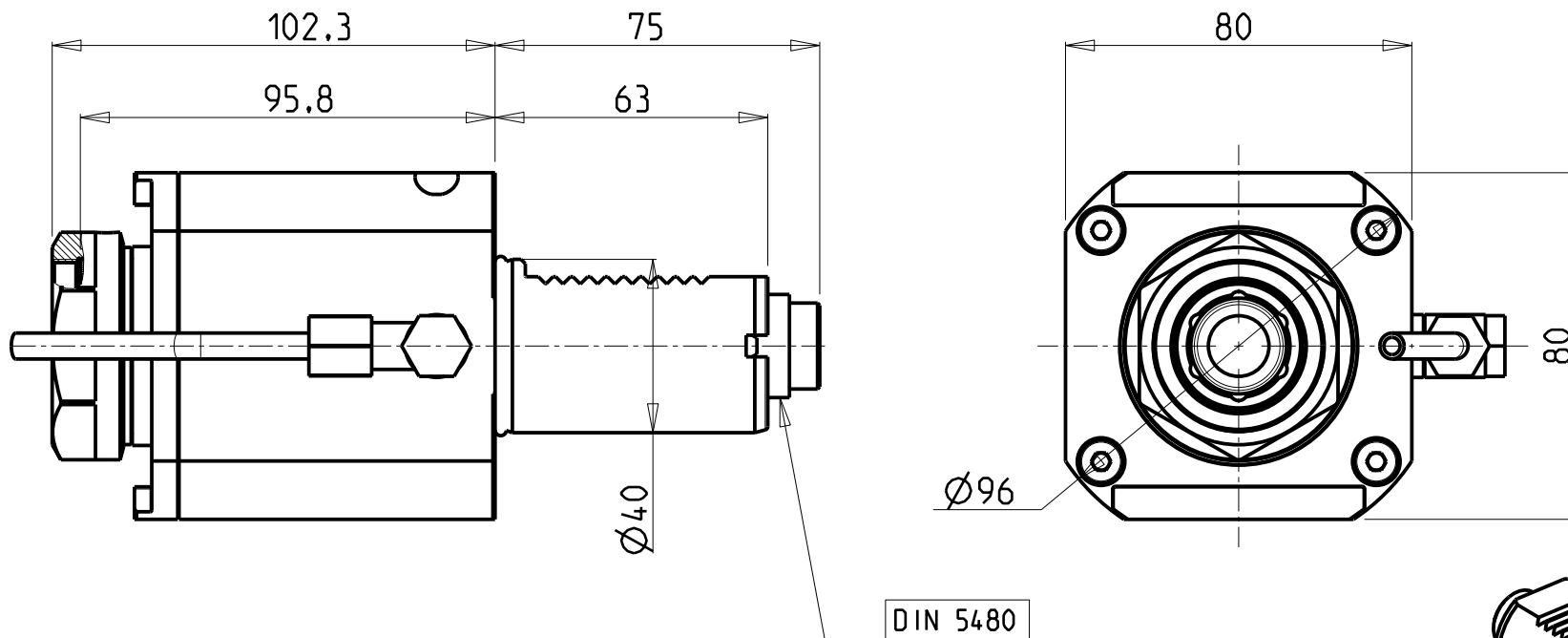

- Chiave inclusa
- Key included
- Schlüssel inbegriffen

PER PORTAUTENSILI MODULARI MTSK-40 VEDI PAG. TBL300-1-40  
 FOR MTSK-40 QUICK CHANGE TOOLHOLDERS CLAMPINGS SEE PAGE TBL300-1-40  
 FUER MTSK-40 MODULARE WERKZEUGAUFNAHMEN SIEHE SEITE TBL300-1-40

Cod. MT	Mandrino Spindle Spindel	i	RPM	Coppia Max Max Torque Max Drehmoment	Lubrificazione int. Coolant through Innenkuehlung	Lubrificazione est. Ext. coolant Aussenkuehlung	CHIAVI NON INCLUSE Keys not included Schlüssel nicht einbegriffen	
							CHUB46	OKU0650004 *
SAU0550140	MTSK-40	1:1	6000	70Nm	-	X	CHUB46	OKU0650004 *
SAU0550240	MTSK-40	1:1	6000	70Nm	P=30bar	X	CHUB46	OKU0650004 *

SAUTER  
VDI 40

MODULO MOTORIZZATO ASSIALE MTSK VDI40 DIN 5480  
 Axial MTSK driven tool VDI40 DIN 5480  
 Axial MTSK angetriebenes Werkzeug VDI40 DIN 5480

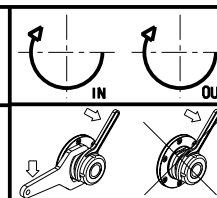

**M.T. srl**  
 Via Casino Albini 480  
 Tel. 0541/956034-957884  
 Fax 0541/956341  
 47842 S. GIOVANNI IN M. (RN)  
 e-mail: mtma@mtmarchetti.com  
 http://www.mtmarchetti.com

PRODUZIONE MODULI ROTANTI



PAGINA SAU017-3-00-K

Subject to change without notice.

10/2018



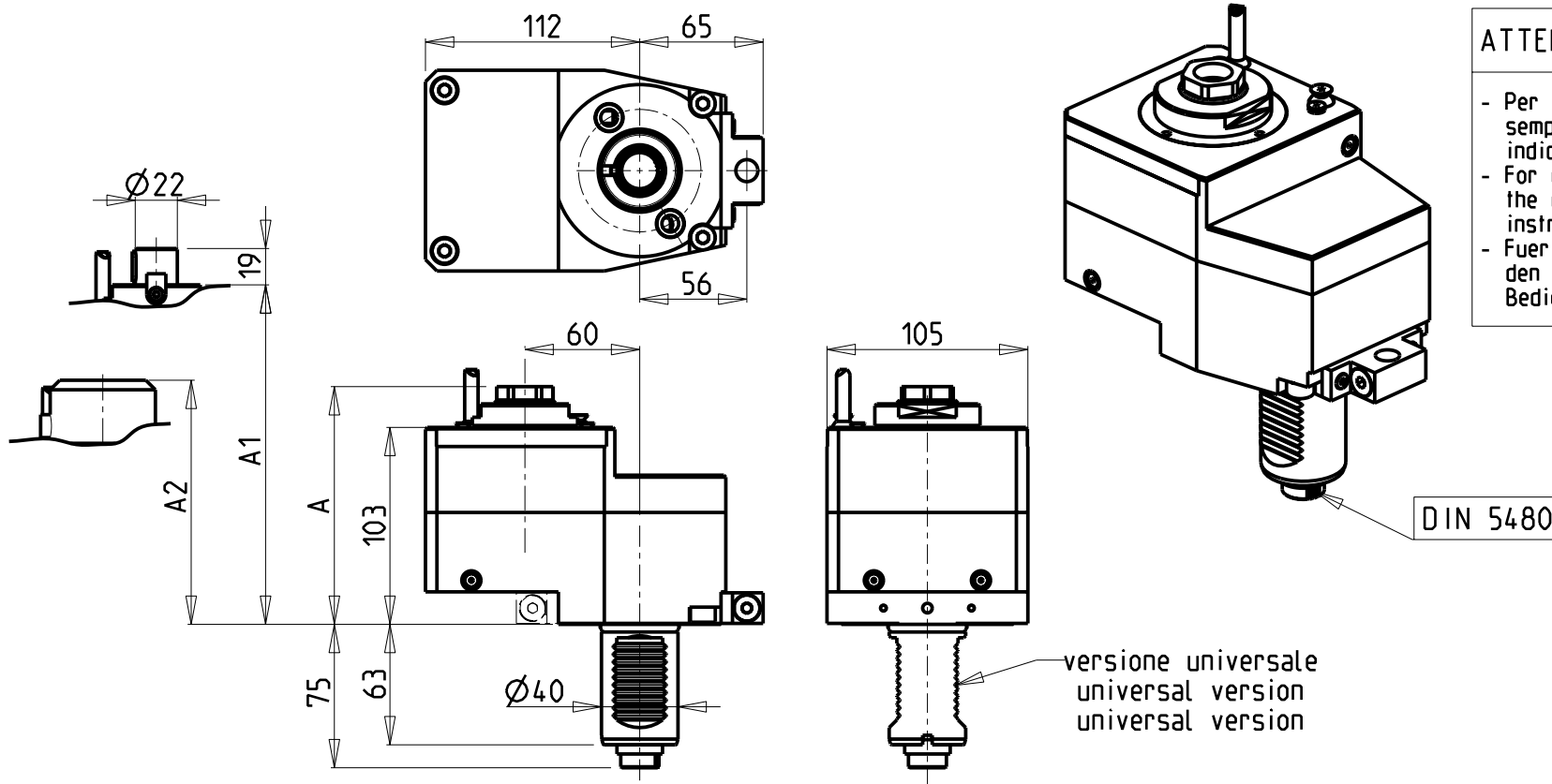

**ATTENZIONE - ATTENTION - ACHTUNG**

- Per lo smontaggio degli utensili utilizzare sempre la chiave di contrasto come indicato nel manuale d'uso.
- For disassembly of the tools use always the contrast key as mentioned in the user instructions.
- Fuer das Abmontieren der Werkzeuge immer den Gegenschlüssel benutzen wie in der Bedienungsanleitung erwäehnt.

DIN 5480

versione universale  
universal version  
universal version

- Chiave inclusa
- Key included
- Schluessel inbegriffen

Cod. MT	Mandrino Spindle Spindel	I	RPM	Coppia Max Max Torque Max Drehmoment	Lubrificazione est. Ext. coolant Aussenkuehlung	Reversibile lato mandrino/controlmandrino Reversible sub/main spindle side Umkehrbare Spindel-seite/Gegenspindel-seite	A	A1	A2	CHIAVI NON INCLUDE Keys not included Schluessel nicht einbegriffen	
SAU0122125	ERA25	1:1	6000	70Nm	X	X	124.33	-	-	CHUB46	CHUB27
SAU0122232	ERA32	1:1	6000	70Nm	X	X	131.53	-	-	CHUB46	CHUB32
SAU0122140	ER40	1:1	6000	70Nm	X	X	143.66	-	-	CHUB46	CHSTER40
SAU0122322	Ø22x19	1:1	6000	70Nm	X	X	-	116	-	CHUB46	CH_VTCROCE_M10 *
SAU0122425	WELDON25	1:1	6000	70Nm	X	X	-	-	137	-	-

SAUTER  
VDI 40

MODULO MOTORIZZATO ASSIALE DISASSATO 60mm VDI40 DIN 5480  
Axial driven tool re-directed by 60mm VDI40 DIN 5480  
Axial angetriebenes Werkzeug achsversetzt um 60mm VDI40 DIN 5480

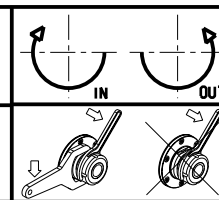

**M.T. srl**

Via Casino Albini 480  
Tel. 0541/956034-957884  
Fax 0541/956341  
47842 S. GIOVANNI IN M. (RN)  
e-mail: mtma@mtmarchetti.com  
http://www.mtmarchetti.com

PRODUZIONE MODULI ROTANTI



PAGINA SAU017-3-05

Subject to change without notice.

10/2018

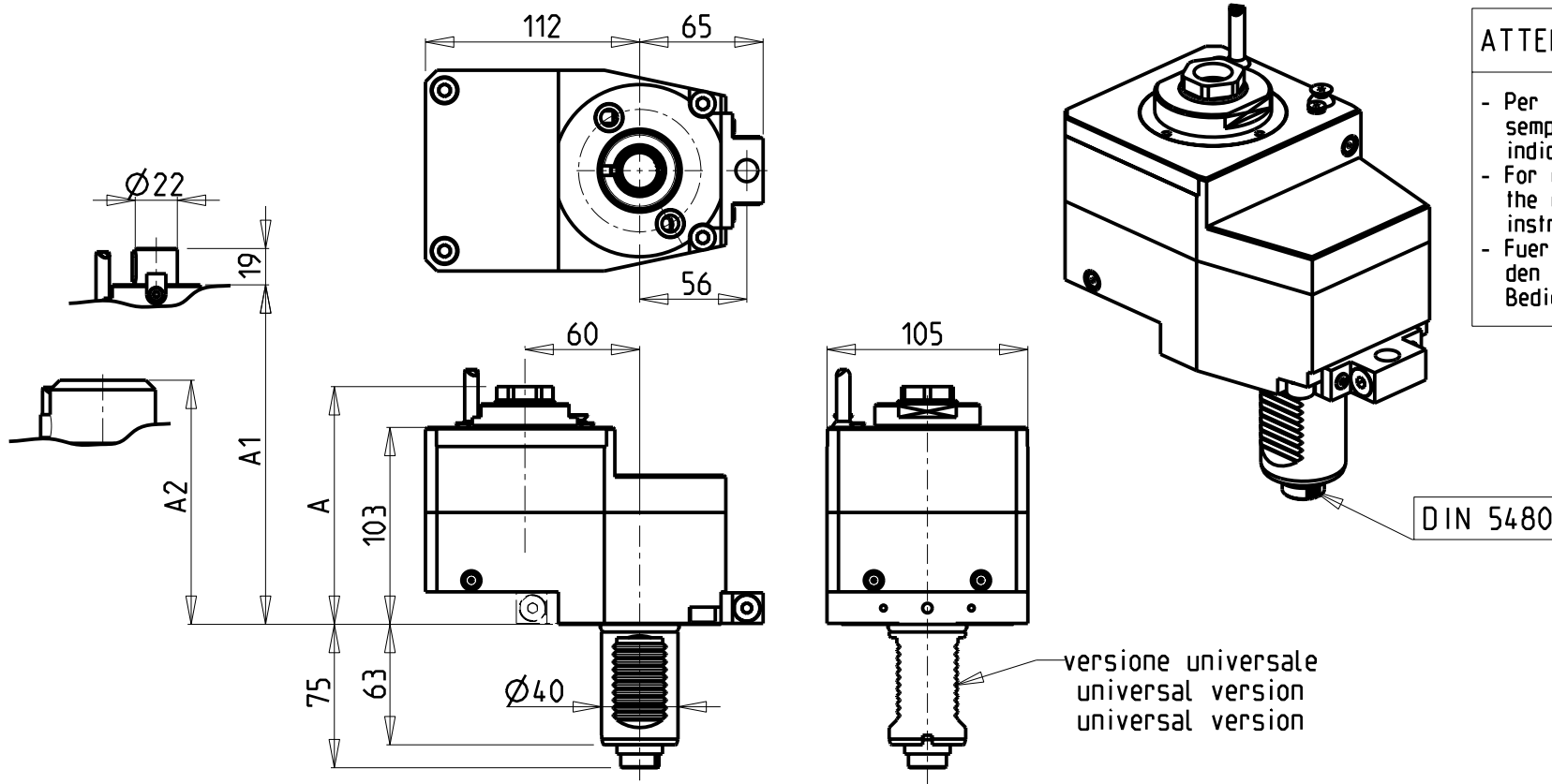

**ATTENZIONE - ATTENTION - ACHTUNG**

- Per lo smontaggio degli utensili utilizzare sempre la chiave di contrasto come indicato nel manuale d'uso.
- For disassembly of the tools use always the contrast key as mentioned in the user instructions.
- Fuer das Abmontieren der Werkzeuge immer den Gegenschlüssel benutzen wie in der Bedienungsanleitung erwaeht.

DIN 5480

versione universale  
universal version  
universal version

Cod. MT	Mandrino Spindle Spindel	I	RPM	Coppia Max Max Torque Max Drehmoment	Lubrificazione est. Ext. coolant Aussenkuehlung	Reversibile lato mandrino/controlmandrino Reversible sub/main spindle side Umkehrbare Spindel-seite/Gegenspindel-seite	A	A1	A2	CHIAVI NON INCLUDE Keys not included Schluessel nicht einbegriffen	
SAU0120125	ERA25	2:1	3000	90Nm	X	X	124.33	-	-	CHUB46	CHUB27
SAU0120232	ERA32	2:1	3000	90Nm	X	X	131.53	-	-	CHUB46	CHUB32
SAU0120140	ER40	2:1	3000	90Nm	X	X	143.66	-	-	CHUB46	CHSTER40
SAU0120322	Ø22x19	2:1	3000	90Nm	X	X	-	116	-	CHUB46	CH_VTCROCE_M10 *
SAU0120425	WELDON25	2:1	3000	90Nm	X	X	-	-	137	-	-

- Chiave inclusa
- Key included
- Schluessel inbegriffen

**SAUTER**  
**VDI 40**

MODULO MOTORIZZATO ASSIALE RIDOTTO I=2:1 DISASSATO 60mm VDI40 DIN 5480  
Axial geared-down I=2:1 driven tool re-directed by 60mm VDI40 DIN 5480  
Axial angetriebenes Werkzeug untersetzt I=2:1 achsversetzt um 60mm VDI40 DIN 5480

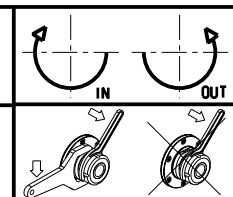

**M.T. srl**  
Via Casino Albini 480  
Tel. 0541/956034-957884  
Fax 0541/956341  
47842 S. GIOVANNI IN M. (RN)  
e-mail: mtma@mtmarchetti.com  
http://www.mtmarchetti.com

PRODUZIONE MODULI ROTANTI



PAGINA SAU017-3-30

Subject to change without notice.

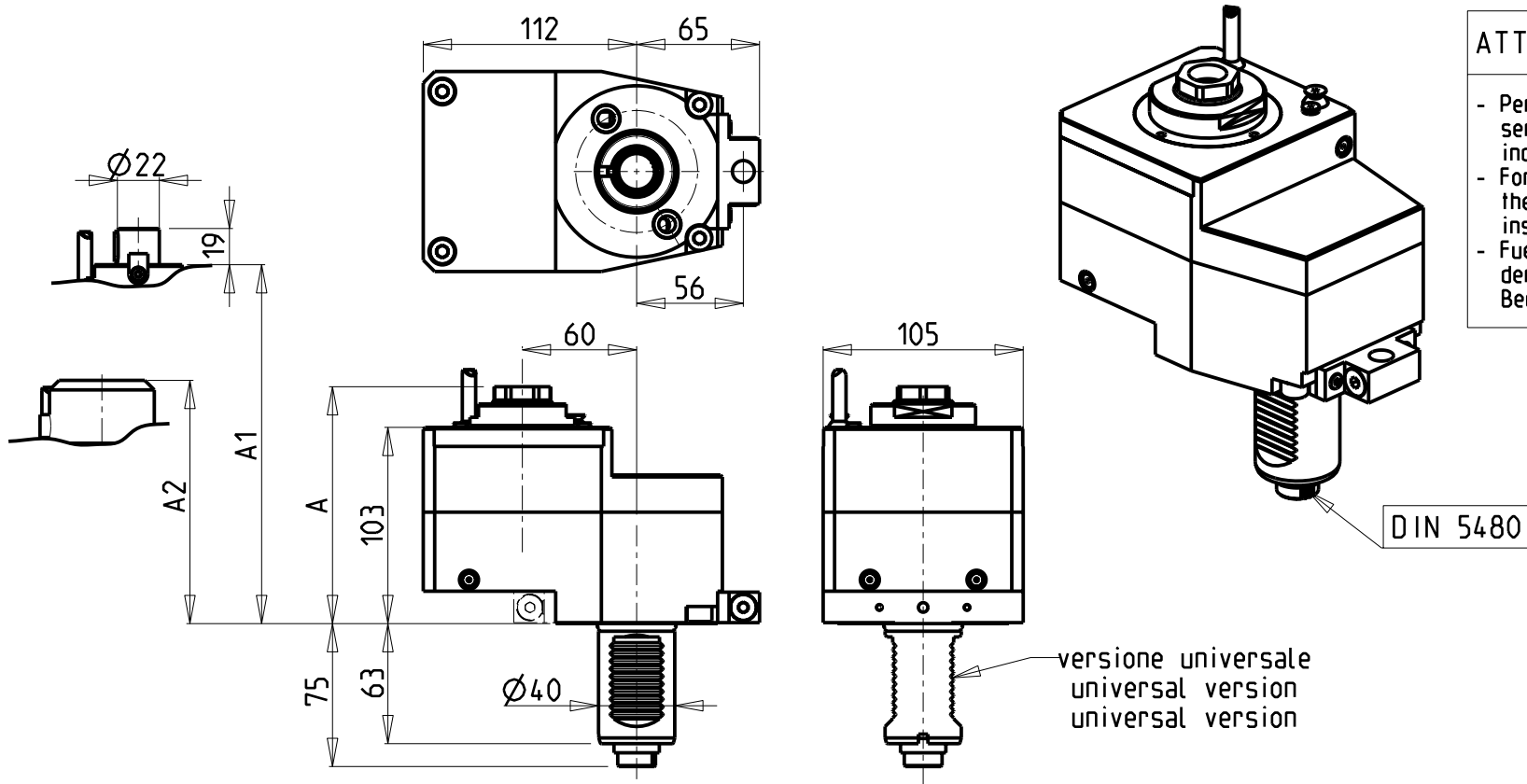

**ATTENZIONE - ATTENTION - ACHTUNG**

- Per lo smontaggio degli utensili utilizzare sempre la chiave di contrasto come indicato nel manuale d'uso.
- For disassembly of the tools use always the contrast key as mentioned in the user instructions.
- Fuer das Abmontieren der Werkzeuge immer den Gegenschlüssel benutzen wie in der Bedienungsanleitung erwäehnt.

DIN 5480

versione universale  
universal version  
universal version

Cod. MT	Mandrino Spindle Spindel	I	RPM	Coppia Max Max Torque Max Drehmoment	Lubrificazione est. Ext. coolant Aussenkuehlung	Reversibile lato mandrino/controlmandrino Reversible sub/main spindle side Umkehrbare Spindel-seite/Gegenspindel-seite	A	A1	A2	CHIAVI NON INCLUDE Keys not included Schluessel nicht einbegriffen	
SAU0121125	ERA25	3:1	2000	130Nm	X	X	124.33	-	-	CHUB46	CHUB27
SAU0121232	ERA32	3:1	2000	130Nm	X	X	131.53	-	-	CHUB46	CHUB32
SAU0121140	ER40	3:1	2000	130Nm	X	X	143.66	-	-	CHUB46	CHSTER40
SAU0121322	Ø22x19	3:1	2000	130Nm	X	X	-	116	-	CHUB46	CH_VTCROCE_M10 *
SAU0121425	WELDON25	3:1	2000	130Nm	X	X	-	-	137	-	-

- Chiave inclusa
- Key included
- Schluessel inbegriffen

**SAUTER**  
**VDI 40**

MODULO MOTORIZZATO ASSIALE RIDOTTO I=3:1 DISASSATO 60mm VDI40 DIN 5480  
Axial geared-down I=3:1 driven tool re-directed by 60mm VDI40 DIN 5480  
Axial angetriebenes Werkzeug untersetzt I=3:1 achsversetzt um 60mm VDI40 DIN 5480

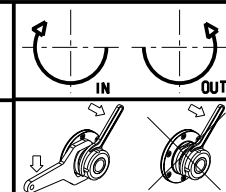

**M.T. srl**  
Via Casino Albini 480  
Tel. 0541/956034-957884  
Fax 0541/956341  
47842 S. GIOVANNI IN M. (RN)  
e-mail: mtma@mtmarchetti.com  
http://www.mtmarchetti.com

PRODUZIONE MODULI ROTANTI



PAGINA SAU017-3-40

Subject to change without notice.

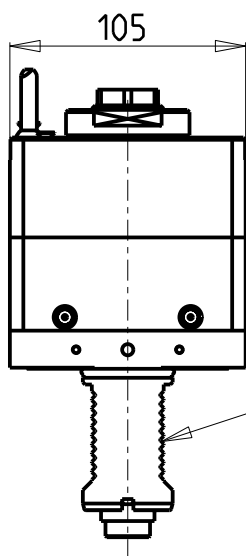
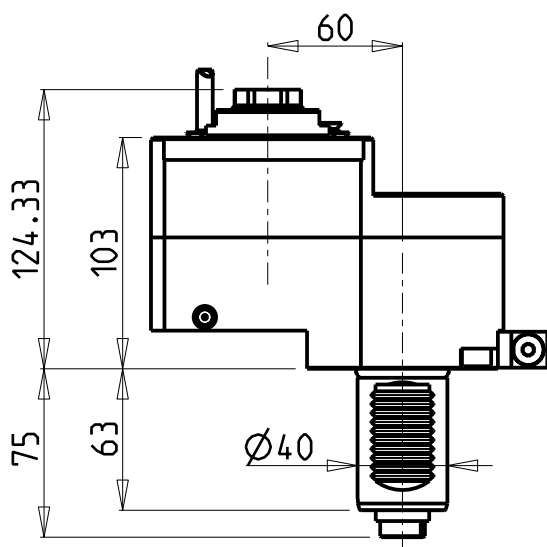
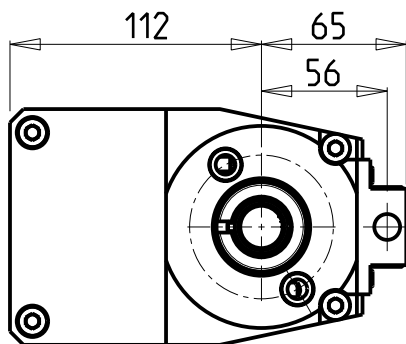

versione universale  
universal version  
universal version

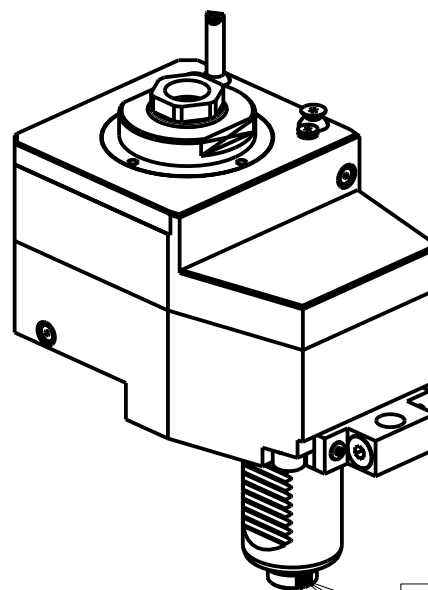

DIN 5480

**ATTENZIONE - ATTENTION - ACHTUNG**

- Per lo smontaggio degli utensili utilizzare sempre la chiave di contrasto come indicato nel manuale d'uso.
- For disassembly of the tools use always the contrast key as mentioned in the user instructions.
- Fuer das Abmontieren der Werkzeuge immer den Gegenschlüssel benutzen wie in der Bedienungsanleitung erwaeht.

Cod. MT	Mandrino Spindle Spindel	i	RPM	Coppia Max Max Torque Max Drehmoment	Lubrificazione est. Ext. coolant Auslenkuehlung	Reversibile lato mandrino/contromandrino Reversible sub/main spindle side Umkehrbare Spindel-seite/ Gegenspindel-seite	CHIAVI NON INCLUSE Keys not included Schlüssel nicht einbegriffen	
SAU0120525	ERA25	1:2	12000	50Nm	X	X	CHUB46	CHUB27

SAUTER  
VDI 40

MODULO MOTORIZZATO ASSIALE MOLTIPLICATO I=1:2 DISASSATO 60mm VDI40 DIN 5480  
Axial geared-up I=1:2 driven tool re-directed by 60mm VDI40 DIN 5480  
Axial angetriebenes Werkzeug uebersetzt I=1:2 achsversetzt um 60mm VDI40 DIN 5480

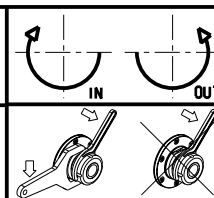

**M.T. srl**

Via Casino Albini 480  
Tel. 0541/956034-957884  
Fax 0541/956341  
47842 S. GIOVANNI IN M. (RN)  
e-mail: mtma@mtmarchetti.com  
http://www.mtmarchetti.com

PRODUZIONE MODULI ROTANTI



PAGINA SAU017-3-60

Subject to change without notice.

10/2018

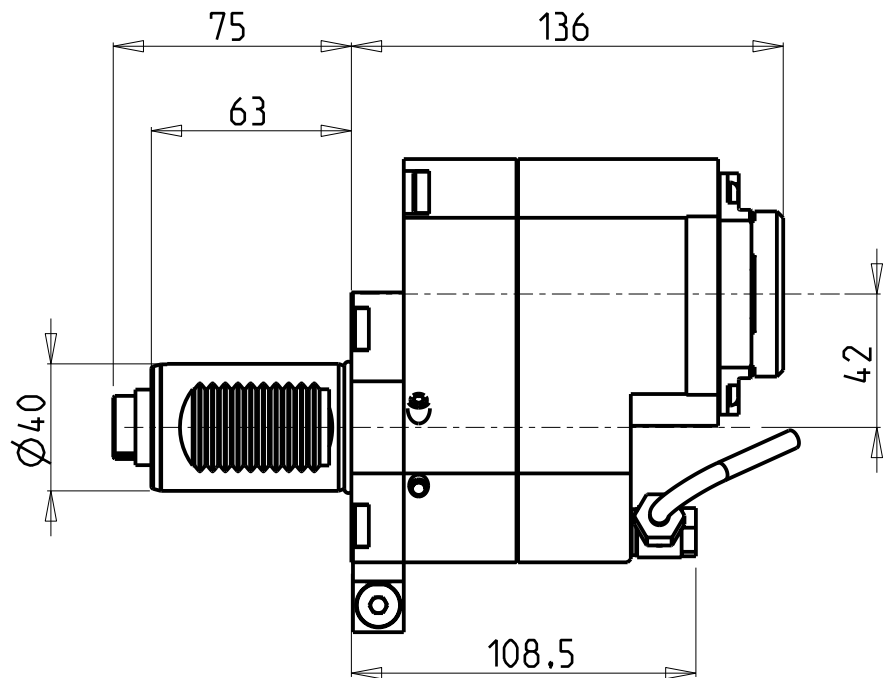

versione universale  
universal version  
universal version

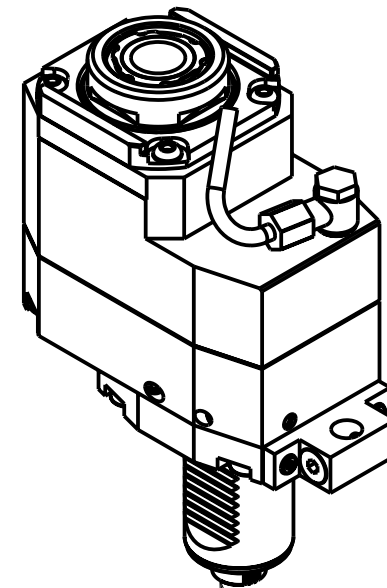
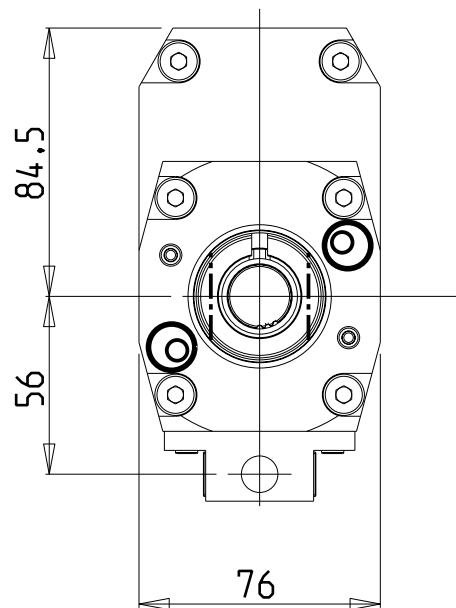

DIN 5480

- Chiave inclusa
- Key included
- Schluessel inbegriffen

Cod. MT	Mandrino Spindle Spindel	I	RPM	Coppia Max Max Torque Max Drehmoment	Lubrificazione int. Coolant through Innenkuehlung	Lubrificazione est. Ext. coolant Ausseinkuehlung	CHIAVI NON INCLUSE Keys not included Schluessel nicht einbegriffen		
SAU0918132	ERA32	1:2	12000	45Nm	-	X	C HUB30	CHTAER32ZC *	OKU0650004 *
SAU0918232	ERA32	1:2	12000	45Nm	P=70bar	X	C HUB30	CHTAER32ZC *	OKU0650004 *

SAUTER  
VDI 40

MODULO MOTORIZZATO ASSIALE MOLTIPLICATO I=1:2 DISASSATO 42mm VDI40 DIN 5480  
Axial geared-up I=1:2 driven tool re-directed by 42mm VDI40 DIN 5480  
Axial angetriebenes Werkzeug uebersetzt I=1:2 achsversetzt um 42mm VDI40 DIN 5480

Subject to change without notice.

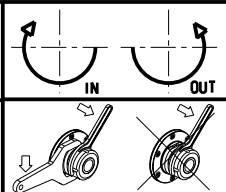

**M.T. srl**  
Via Casino Albini 480  
Tel. 0541/956034-957884  
Fax 0541/956341  
47842 S. GIOVANNI IN M. (RN)  
e-mail: mtma@mtmarchetti.com  
http://www.mtmarchetti.com

PRODUZIONE MODULI ROTANTI



PAGINA SAU017-3-61

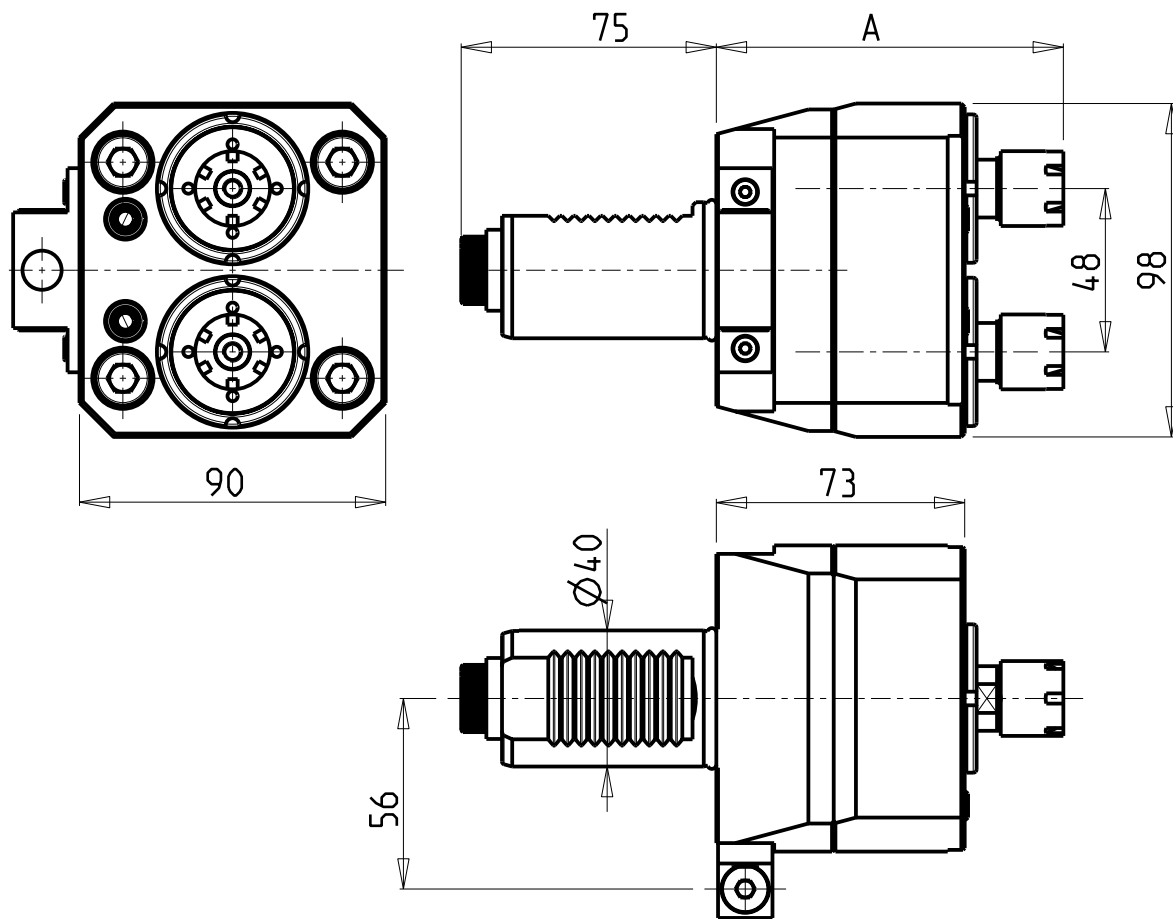

### ATTENZIONE - ATTENTION - ACHTUNG

- Per lo smontaggio degli utensili utilizzare sempre la chiave di contrasto come indicato nel manuale d'uso.
- For disassembly of the tools use always the contrast key as mentioned in the user instructions.
- Fuer das Abmontieren der Werkzeuge immer den Gegenschlüssel benutzen wie in der Bedienungsanleitung erwäehnt.

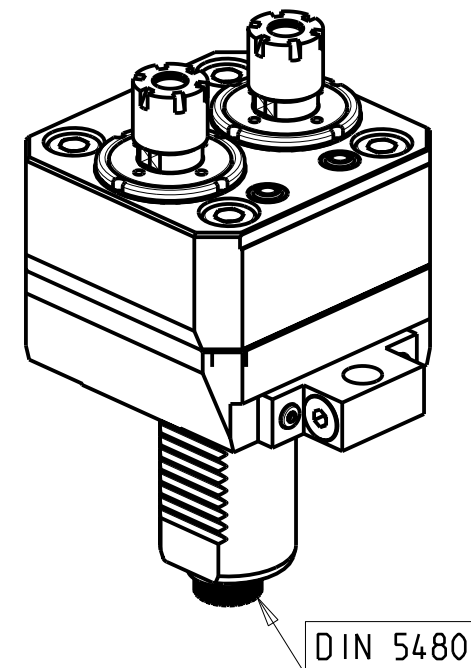

Cod. MT		Mandrino Spindle Spindel	I	RPM	Coppia Max Max Torque Max Drehmoment	Lubrificazione est. Ext. coolant Auslenkuehlung	A	CHIAVI NON INCLUSE Keys not included Schluesssel nicht einbegriffen	
versione dx right version version rechts	versione sx left version version links							CHUB17	CHMNER16
SAU0450216	SAU0451216	ER16	1:1	6000	30Nm	X	102	CHUB17	CHMNER16
SAU0450225	SAU0451225	ER25	1:1	6000	30Nm	X	102.96	CHUB36	CHSTER25

SAUTER  
VDI 40

MODULO MOTORIZZATO ASSIALE 2 USCITE IN Y VDI40 DIN 5480  
Axial single side twin head driven tool in Y VDI40 DIN 5480  
Axial angetriebenes Werkzeug 2 Ausgaenge in Y VDI40 DIN 5480

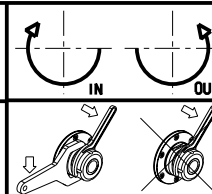

**M.T. srl**

Via Casino Albini 480  
Tel. 0541/956034-957884  
Fax 0541/956341  
47842 S. GIOVANNI IN M. (RN)  
e-mail: mtma@mtmarchetti.com  
http://www.mtmarchetti.com

PRODUZIONE MODULI ROTANTI



PAGINA SAU017-3-80

Subject to change without notice.

10/2018

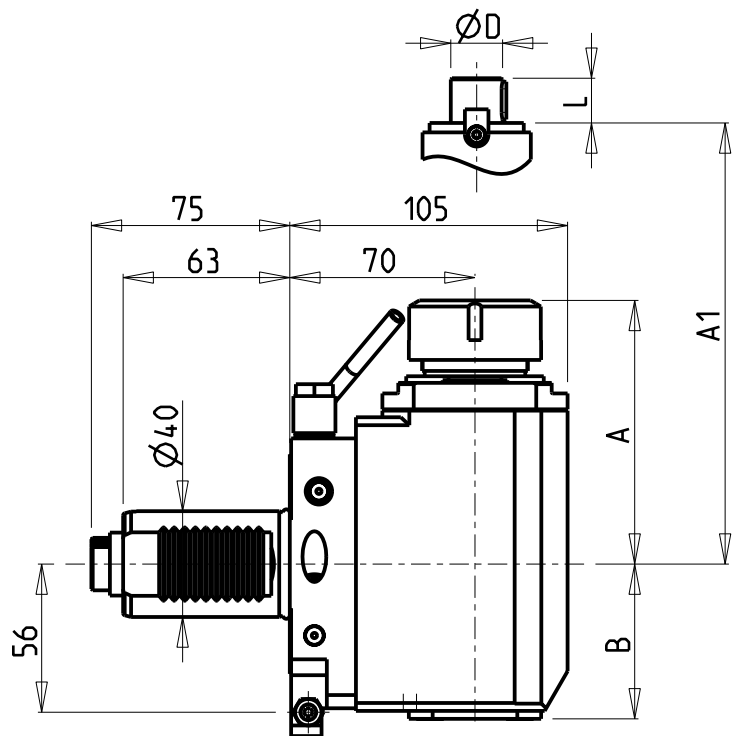

versione dx  
right version  
version rechts

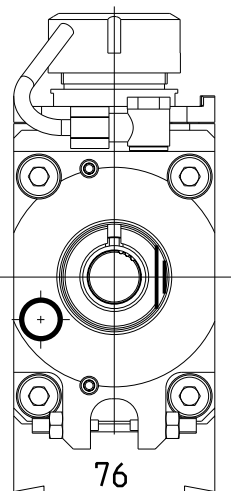

versione sx  
left version  
version links

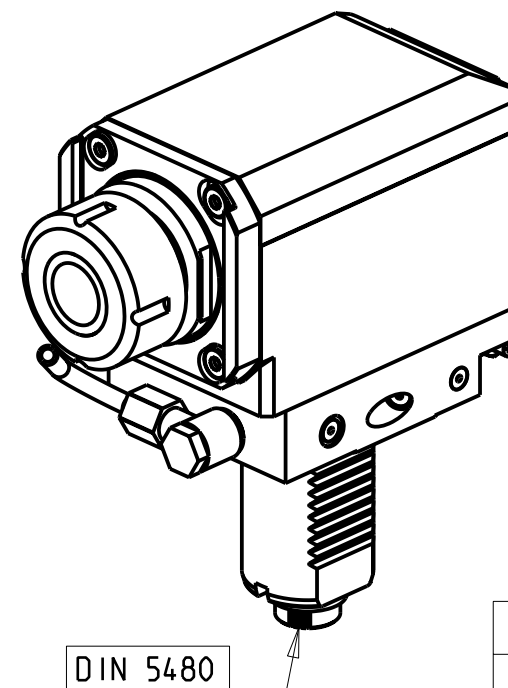
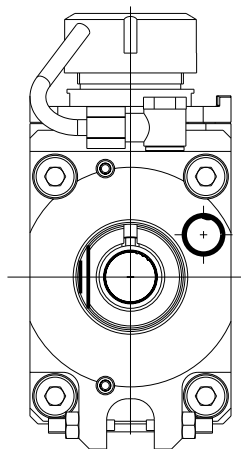

DIN 5480

- Chiave inclusa
- Key included
- Schlüssel inbegriffen

Cod. MT		Mandrino Spindle Spindel	I	RPM	Coppia Max Max Torque Max Drehmoment	Lubrificazione int. Coolant through Innenkuehlung	Lubrificazione est. Exl. coolant Aussenkuehlung	A	A1	B	D	L	CHIAVI NON INCLUDE Keys not included Schlüssel nicht einbegriffen	
versione dx right version version rechts	versione sx left version version links													
SAU0840132	SAU0841132	ER32	1:1	6000	70Nm	-	X	99.7	-	58.5	-	-	OKU0650004	CHSTER32
SAU0840232	SAU0841232	ER32	1:1	6000	70Nm	P=70bar	X	99.7	-	69.5	-	-	OKU0650004	CHSTER32
SAU0840140	SAU0841140	ER40	1:1	6000	70Nm	-	X	103.7	-	58.5	-	-	OKU0650004	CHSTER40
SAU0840240	SAU0841240	ER40	1:1	6000	70Nm	P=70bar	X	103.7	-	69.5	-	-	OKU0650004	CHSTER40
215SAU_R22_40D00	215SAU_R22_40D10	Ø22x19	1:1	6000	70Nm	-	X	-	78.5	58.5	22	19	CHUB41	CH_VTCROCE_M10
215SAU_R27_40D00	215SAU_R27_40D10	Ø27x21	1:1	6000	70Nm	-	X	-	78.5	58.5	27	21	CHUB41	CH_VTCROCE_M12

SAUTER  
VDI 40

MODULO MOTORIZZATO RADIALE VDI40 DIN 5480 H=70mm  
Radial driven tool VDI40 DIN 5480 H=70mm  
Radial angetriebenes Werkzeug VDI40 DIN 5480 H=70mm

Subject to change without notice.

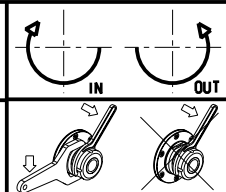

**M.T. srl**  
Via Casino Albini 480  
Tel. 0541/956034-957884  
Fax 0541/956341  
47842 S. GIOVANNI IN M. (RN)  
e-mail: mtma@tmarchetti.com  
http://www.mtmarchetti.com

PRODUZIONE MODULI ROTANTI



PAGINA SAU018-3-00

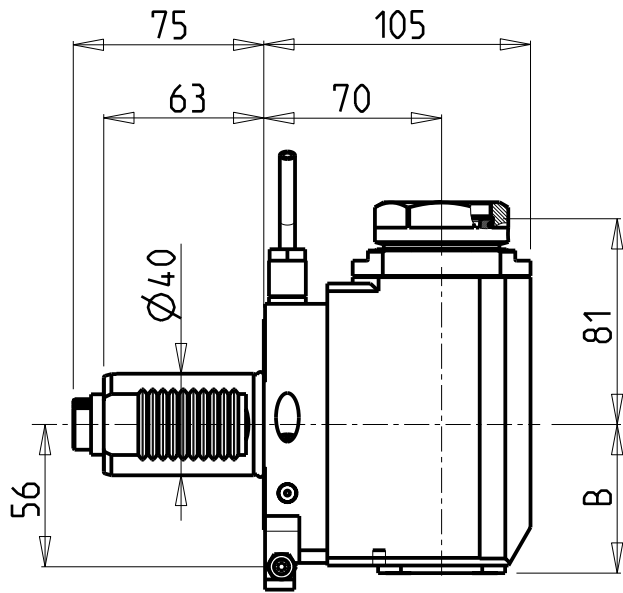

versione dx  
right version  
version rechts

versione sx  
left version  
version links

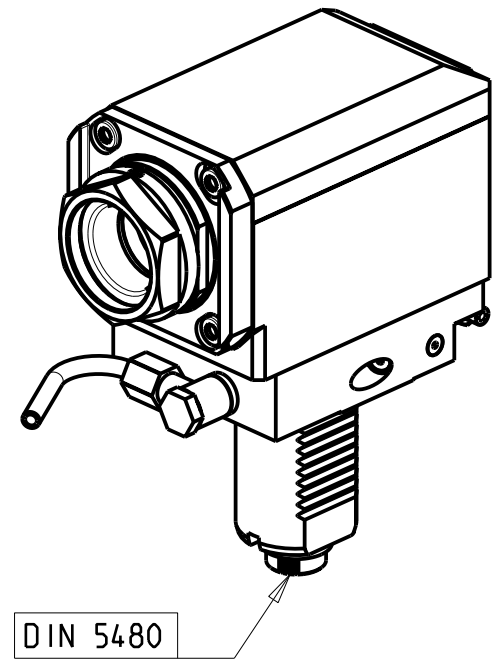
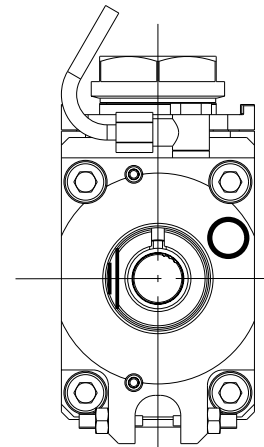
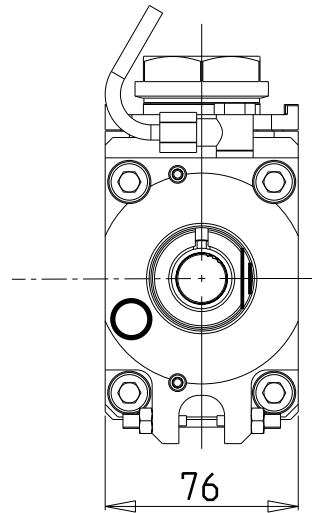

DIN 5480

PER PORTAUTENSILI MODULARI MTSK-40 VEDI PAG. TBL300-1-40  
FOR MTSK-40 QUICK CHANGE TOOLHOLDERS CLAMPINGS SEE PAGE TBL300-1-40  
FUER MTSK-40 MODULARE WERKZEUGAUFNAHMEN SIEHE SEITE TBL300-1-40

- Chiave inclusa
- Key included
- Schlüssel inbegriffen

Cod. MT		Mandrino Spindle Spindel	I	RPM	Coppia Max Max Torque Max Drehmoment	Lubrificazione int. Coolant through Innenkuehlung	Lubrificazione est. Ext. coolant Aussenkuehlung	B	CHIAVI NON INCLUSE Keys not included Schlüssel nicht einbegriffen	
versione dx right version version rechts	versione sx left version version links									
SAU0410140	SAU0411140	MTSK-40	1:1	6000	70Nm	-	X	58.5	CHUB46	OKU0650004 •
SAU0410240	SAU0411240	MTSK-40	1:1	6000	70Nm	P=70bar	X	69.5	CHUB46	OKU0650004 •

SAUTER  
VDI 40

MODULO MOTORIZZATO RADIALE MTSK VDI40 DIN 5480 H=70mm  
Radial MTSK driven tool VDI40 DIN 5480 H=70mm  
Radial MTSK angetriebenes Werkzeug VDI40 DIN 5480 H=70mm

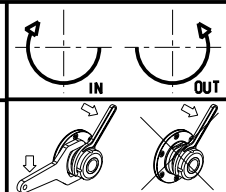

**M.T. srl**  
Via Casino Albini 480  
Tel. 0541/956034-957884  
Fax 0541/956341  
47842 S. GIOVANNI IN M. (RN)  
e-mail: mtma@mtmarchetti.com  
http://www.mtmarchetti.com

PRODUZIONE MODULI ROTANTI

PAGINA SAU018-3-00-K

Subject to change without notice.



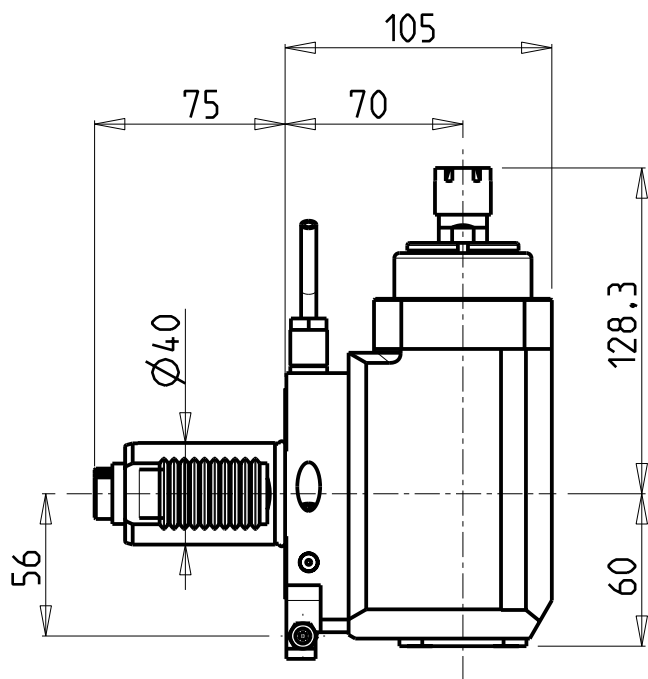

versione dx  
right version  
version rechts

versione sx  
left version  
version links

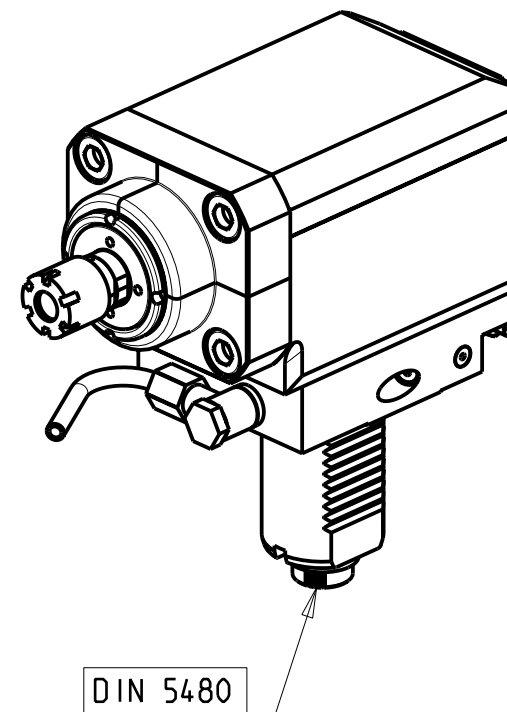
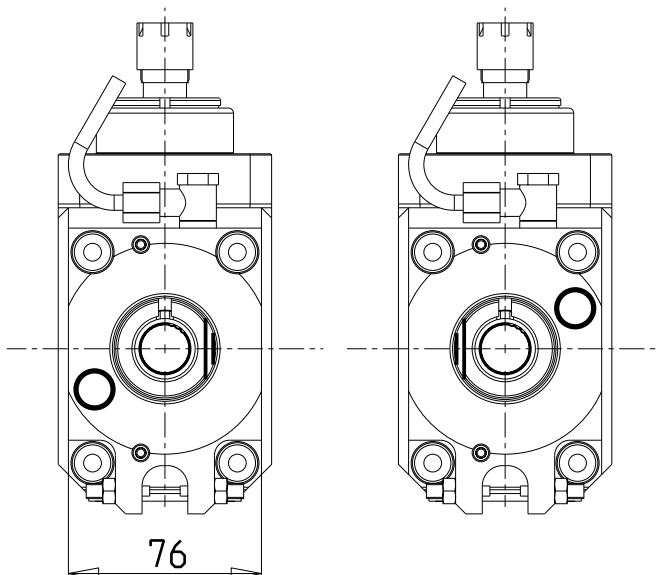

DIN 5480

Cod. MT		Mandrino Spindle Spindel	i	RPM	Coppia Max Max Torque Max Drehmoment	Lubrificazione est. Ext. coolant Aussenkuehlung	CHIAVI INCLUSE Keys included Schlüssel einbegriffen	
versione dx right version version rechts	versione sx left version version links						CHUB17	CHMNER16
SAU0580016	SAU0581016	ER16	1:3	18000	10Nm	X	CHUB17	CHMNER16

SAUTER  
VDI 40

MODULO MOTORIZZATO RADIALE MOLTIPLICATO I=1:3 VDI40 DIN 5480 H=70mm  
Radial geared-up I=1:3 driven tool VDI40 DIN 5480 H=70mm  
Radial angetriebenes Werkzeug uebersetzt I=1:3 VDI40 DIN 5480 H=70mm

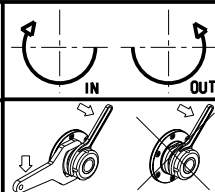

**M.T. srl**  
Via Casino Albini 480  
Tel. 0541/956034-957884  
Fax 0541/956341  
47842 S. GIOVANNI IN M. (RN)  
e-mail: mtma@mtmarchetti.com  
http://www.mtmarchetti.com

PRODUZIONE MODULI ROTANTI



PAGINA SAU018-3-04

Subject to change without notice.

10/2018

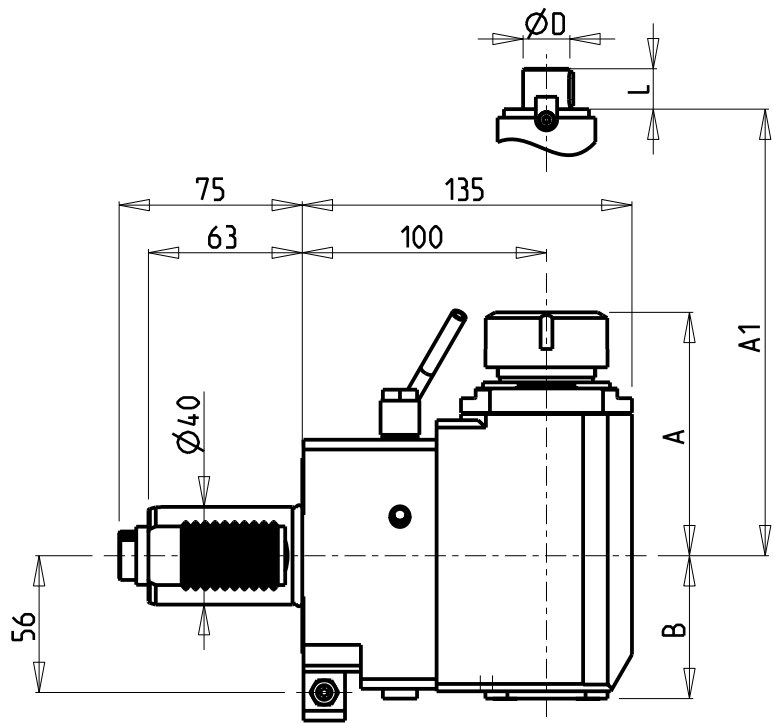

versione dx  
right version  
version rechts

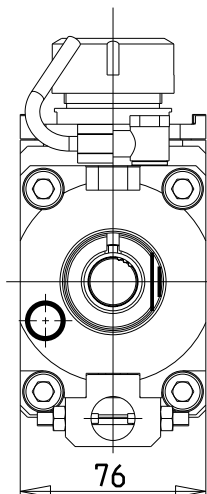

versione universale  
universal version  
universal version

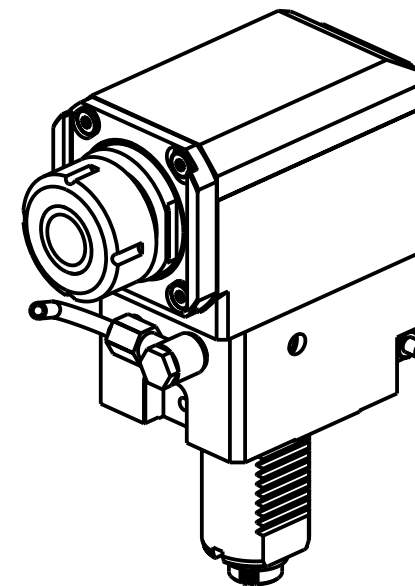
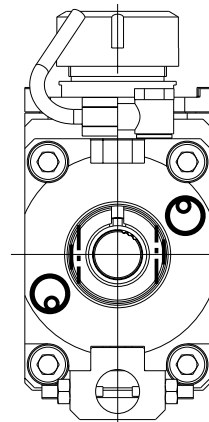

DIN 5480

- Chiave inclusa
- Key included
- Schlüssel inbegriffen

Cod. MT		Mandrino Spindle Spindel	I	RPM	Coppia Max Max Torque Max Drehmoment	Lubrificazione int. Coolant through Innenkuehlung	Lubrificazione est. Ext. coolant Aussenkuehlung	A	A1	B	D	L	CHIAVI NON INCLUDE Keys not included Schlüssel nicht einbegriffen	
versione dx right version version rechts	versione universale universal version universal version													
SAU0820132	SAU0822132	ER32	1:1	6000	70Nm	-	X	99.7	-	58.5	-	-	OKU0650004	CHSTER32
SAU0820232	SAU0822232	ER32	1:1	6000	70Nm	P=70bar	X	99.7	-	69.5	-	-	OKU0650004	CHSTER32
SAU0820140	SAU0822140	ER40	1:1	6000	70Nm	-	X	103.7	-	58.5	-	-	OKU0650004	CHSTER40
SAU0820240	SAU0822240	ER40	1:1	6000	70Nm	P=70bar	X	103.7	-	69.5	-	-	OKU0650004	CHSTER40
213SAU_R22_40D00	213SAU_R22_40D02	Ø22x19	1:1	6000	70Nm	-	X	-	78.5	58.5	22	19	CHUB41	CH_VTCROCE_M10
213SAU_R27_40D00	213SAU_R27_40D02	Ø27x21	1:1	6000	70Nm	-	X	-	78.5	58.5	27	21	CHUB41	CH_VTCROCE_M12

SAUTER  
VDI 40

MODULO MOTORIZZATO RADIALE VDI40 DIN 5480 H=100mm  
Radial driven tool VDI40 DIN 5480 H=100mm  
Radial angetriebenes Werkzeug VDI40 DIN 5480 H=100mm

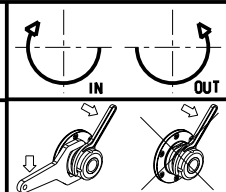

**M.T. srl**  
Via Casino Albini 480  
Tel. 0541/956034-957884  
Fax 0541/956341  
47842 S. GIOVANNI IN M. (RN)  
e-mail: mtma@mtmarchetti.com  
http://www.mtmarchetti.com

PRODUZIONE MODULI ROTANTI



PAGINA SAU018-3-10

Subject to change without notice.

10/2018

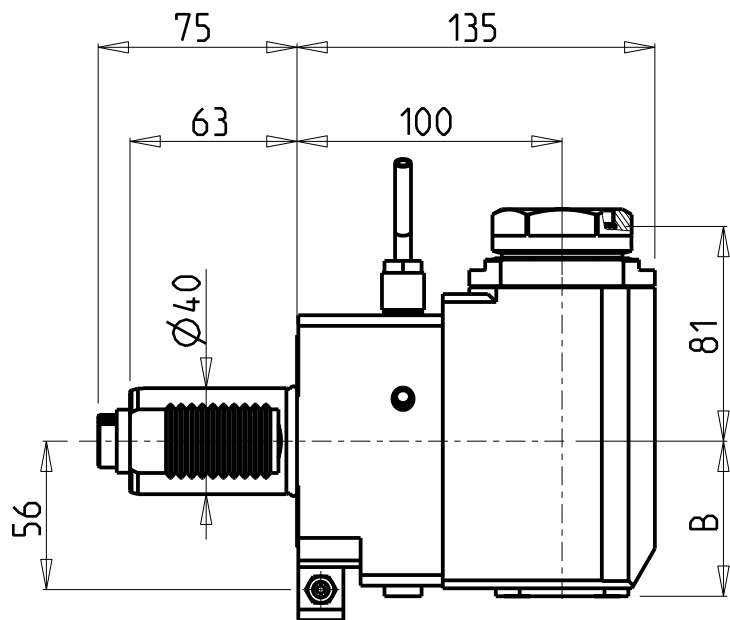

versione dx  
right version  
version rechts

versione universale  
universal version  
universal version

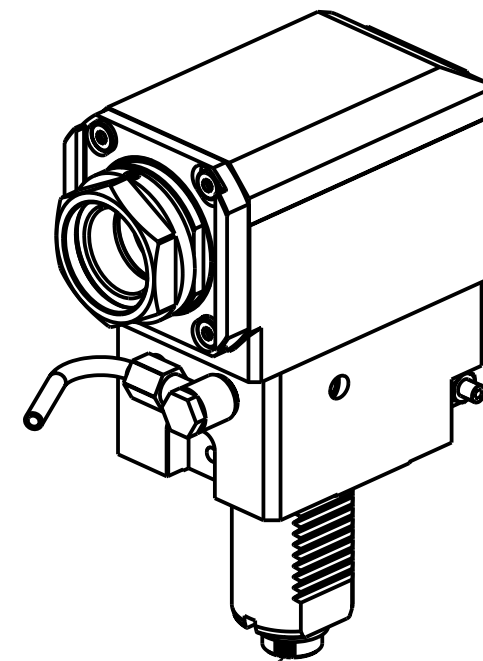
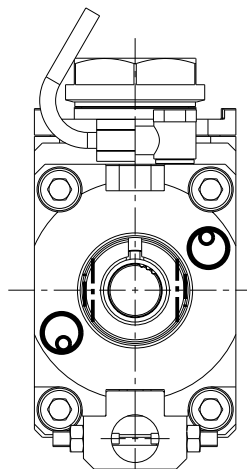
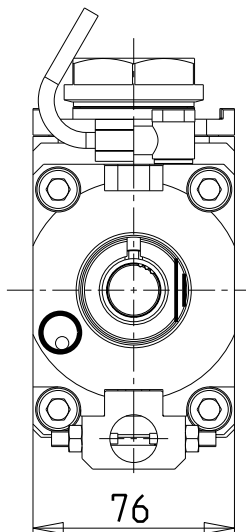

DIN 5480

PER PORTAUTENSILI MODULARI MTSK-40 VEDI PAG. TBL300-1-40  
FOR MTSK-40 QUICK CHANGE TOOLHOLDERS CLAMPINGS SEE PAGE TBL300-1-40  
FUER MTSK-40 MODULARE WERKZEUGAUFNAHMEN SIEHE SEITE TBL300-1-40

Cod. MT		Mandrino Spindle Spindel	I	RPM	Coppia Max Max Torque Max Drehmoment	Lubrificazione int. Coolant through Innenkuehlung	Lubrificazione est. Ext. coolant Aussenkuehlung	B	CHIAVI NON INCLUSE Keys not included Schluessel nicht einbegriffen	
versione dx right version version rechts	versione universale universal version universal version								CHUB46	OKU0650004 *
SAU0420140	SAU0422140	MTSK-40	1:1	6000	70Nm	-	X	58.5	CHUB46	OKU0650004 *
SAU0420240	SAU0422240	MTSK-40	1:1	6000	70Nm	P=70bar	X	69.5	CHUB46	OKU0650004 *

- Chiave inclusa
- Key included
- Schluessel inbegriffen

SAUTER  
VDI 40

MODULO MOTORIZZATO RADIALE MTSK VDI40 DIN 5480 H=100mm  
Radial MTSK driven tool VDI40 DIN 5480 H=100mm  
Radial MTSK angetriebenes Werkzeug VDI40 DIN 5480 H=100mm

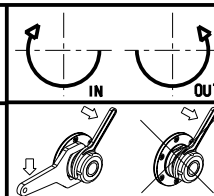

**M.T. srl**  
Via Casino Albini 480  
Tel. 0541/956034-957884  
Fax 0541/956341  
47842 S. GIOVANNI IN M. (RN)  
e-mail: mtma@mtmarchetti.com  
http://www.mtmarchetti.com

PRODUZIONE MODULI ROTANTI



PAGINA SAU018-3-10-K

Subject to change without notice.

10/2018

versione universale  
universal version  
universal version

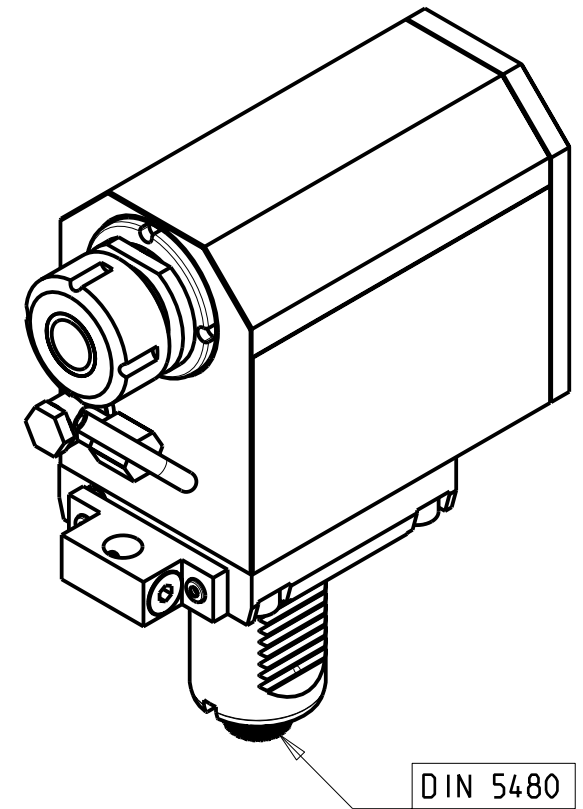
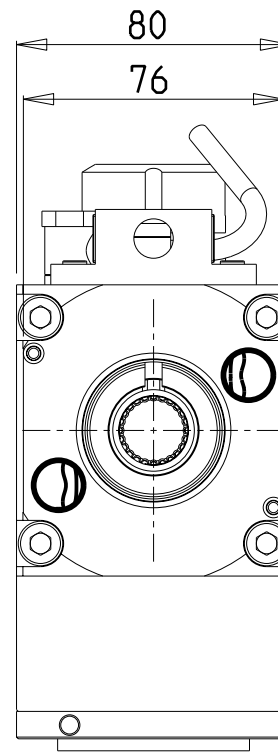
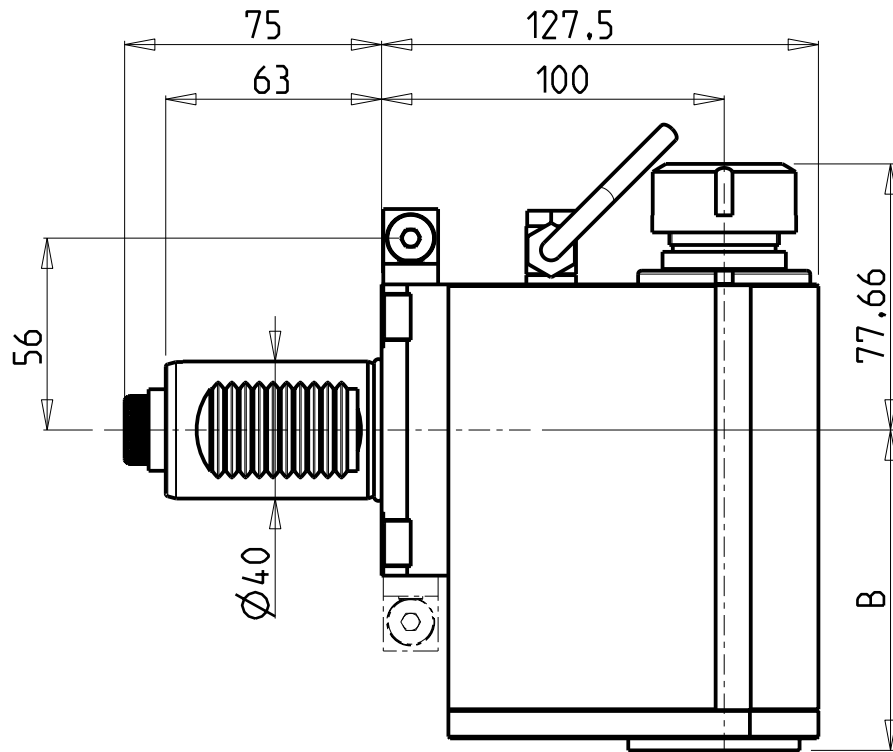

DIN 5480

Cod. MT	Mandrino Spindle Spindel	i	RPM MAX	Coppia Max Max Torque Max Drehmoment	Lubrificazione int. Coolant through Innenkuehlung	Lubrificazione est. Ext. coolant Aussenkuehlung	B	CHIAVI NON INCLUSE Keys not included Schluessel nicht einbegriffen	
SAU0310125	ER25	1:3	12000	40Nm		X	93.5	CHUB36	CHSTER25
SAU0310225	ER25	1:3	12000	40Nm	P=70bar	X	103.5	CHUB36	CHSTER25

SAUTER  
VDI 40

MODULO MOTORIZZATO RADIALE MOLTIPLICATO I=1:3 VDI40 DIN 5480  
Radial geared-up I=1:3 driven tool VDI40 DIN 5480  
Radial angetriebenes Werkzeug uebersetzt I=1:3 VDI40 DIN 5480

Subject to change without notice.

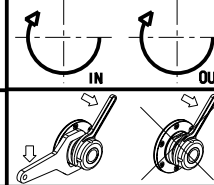

**M.T. srl**

Via Casino Albini 480  
Tel. 0541/956034-957884  
Fax 0541/956341  
47842 S. GIOVANNI IN M. (RN)  
e-mail: mtma@mtmarchetti.com  
http://www.mtmarchetti.com

PRODUZIONE MODULI ROTANTI



PAGINA SAU018-3-14

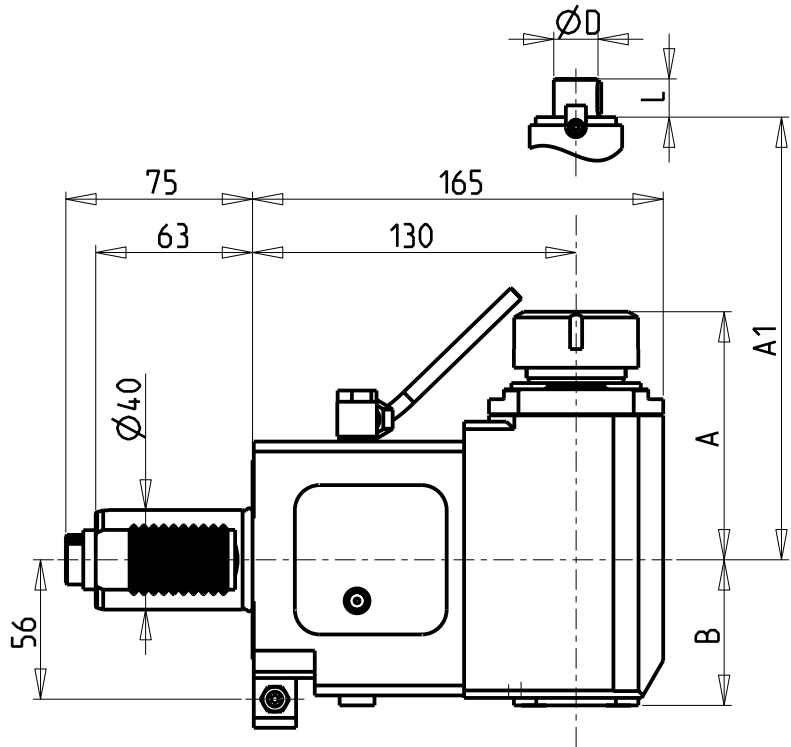

versione dx  
right version  
version rechts

versione sx  
left version  
version links

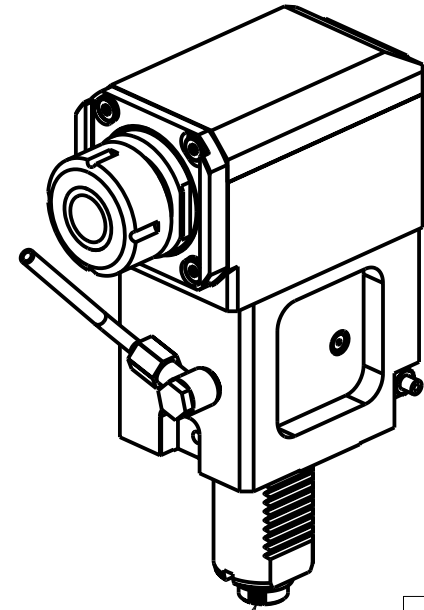
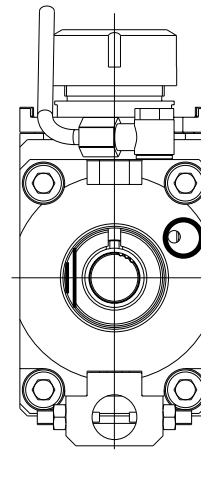
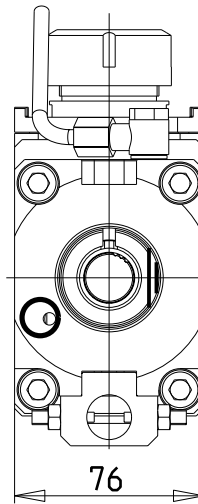

DIN 5480

- Chiave inclusa
- Key included
- Schlüssel inbegriffen

Cod. MT		Mandrino Spindle Spindel	I	RPM	Coppia Max Max Torque Max Drehmoment	Lubrificazione int. Coolant through Innenkuehlung	Lubrificazione est. Ext. coolant Aussenkuehlung	A	A1	B	D	L	CHIAVI NON INCLUDE Keys not included Schlüssel nicht einbegriffen	
versione dx right version version rechts	versione sx left version version links													
SAU0830132	SAU0831132	ER32	1:1	6000	70Nm	-	X	99.7	-	58.5	-	-	OKU0650004	CHSTER32
SAU0830232	SAU0831232	ER32	1:1	6000	70Nm	P=70bar	X	99.7	-	69.5	-	-	OKU0650004	CHSTER32
SAU0830140	SAU0831140	ER40	1:1	6000	70Nm	-	X	103.7	-	58.5	-	-	OKU0650004	CHSTER40
SAU0830240	SAU0831240	ER40	1:1	6000	70Nm	P=70bar	X	103.7	-	69.5	-	-	OKU0650004	CHSTER40
SAU0830522	SAU0831522	Ø22x19	1:1	6000	70Nm	-	X	-	78.5	58.5	22	19	CHUB41	CH_VTCROCE_M10
SAU0830527	SAU0831527	Ø27x21	1:1	6000	70Nm	-	X	-	78.5	58.5	27	21	CHUB41	CH_VTCROCE_M12

SAUTER  
VDI 40

MODULO MOTORIZZATO RADIALE VDI40 DIN 5480 H=130mm  
Radial driven tool VDI40 DIN 5480 H=130mm  
Radial angetriebenes Werkzeug VDI40 DIN 5480 H=130mm

Subject to change without notice.

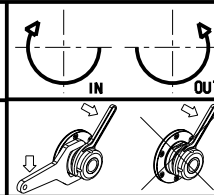

**M.T. srl**

Via Casino Albini 480  
Tel. 0541/956034-957884  
Fax 0541/956341  
47842 S. GIOVANNI IN M. (RN)  
e-mail: mtma@mtmarchetti.com  
http://www.mtmarchetti.com

PRODUZIONE MODULI ROTANTI



PAGINA SAU018-3-20

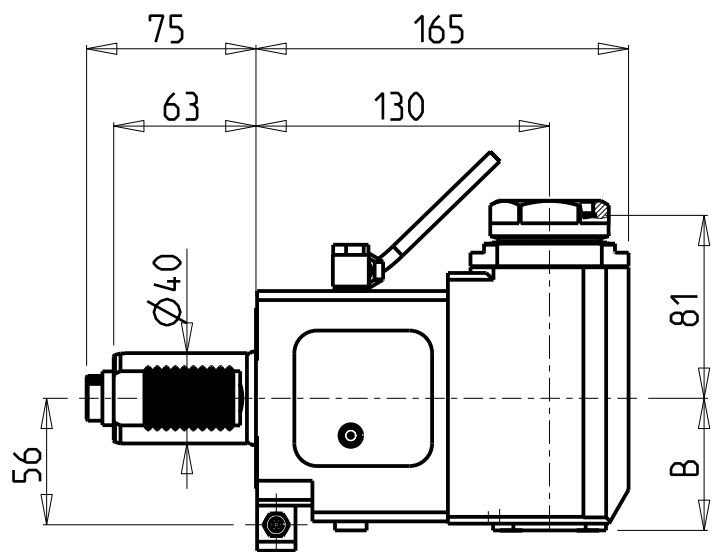

versione dx  
right version  
version rechts

versione sx  
left version  
version links

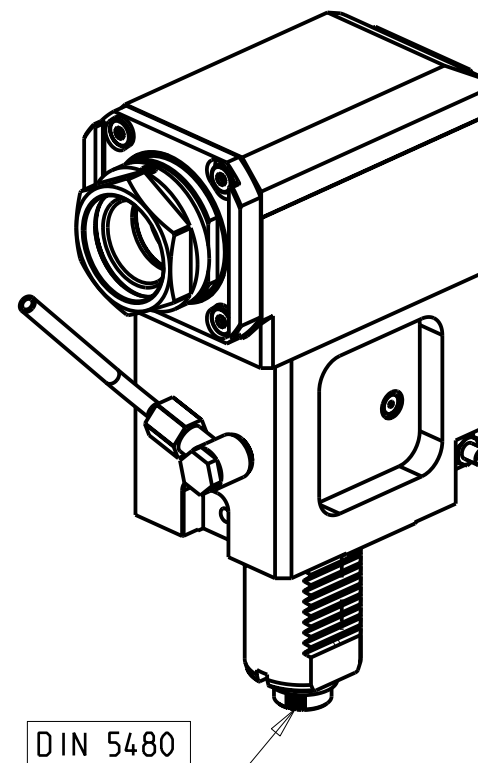
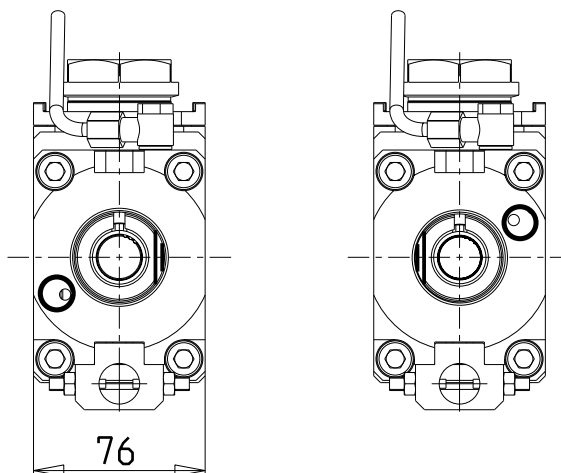

DIN 5480

- Chiave inclusa
- Key included
- Schluessel inbegriffen

PER PORTAUTENSILI MODULARI MTSK-40 VEDI PAG. TBL300-1-40  
FOR MTSK-40 QUICK CHANGE TOOLHOLDERS CLAMPINGS SEE PAGE TBL300-1-40  
FUER MTSK-40 MODULARE WERKZEUGAUFNAHMEN SIEHE SEITE TBL300-1-40

Cod. MT		Mandrino Spindle Spindel	I	RPM	Coppia Max Max Torque Max Drehmoment	Lubrificazione int. Coolant through Innenkuehlung	Lubrificazione est. Ext. coolant Aussenkuehlung	B	CHIAVI NON INCLUSE Keys not included Schluessel nicht einbegriffen	
versione dx right version version rechts	versione sx left version version links									
SAU0430140	SAU0431140	MTSK-40	1:1	6000	70Nm	-	X	58.5	CHUB46	OKU0650004 •
SAU0430240	SAU0431240	MTSK-40	1:1	6000	70Nm	P=70bar	X	69.5	CHUB46	OKU0650004 •

SAUTER  
VDI 40

MODULO MOTORIZZATO RADIALE MTSK VDI40 DIN 5480 H=130mm  
Radial MTSK driven tool VDI40 DIN 5480 H=130mm  
Radial MTSK angetriebenes Werkzeug VDI40 DIN 5480 H=130mm

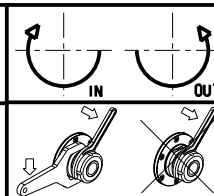

**M.T. srl**  
Via Casino Albini 480  
Tel. 0541/956034-957884  
Fax 0541/956341  
47842 S. GIOVANNI IN M. (RN)  
e-mail: mtma@mtmarchetti.com  
http://www.mtmarchetti.com

PRODUZIONE MODULI ROTANTI



PAGINA SAU018-3-20-K

Subject to change without notice.

10/2018

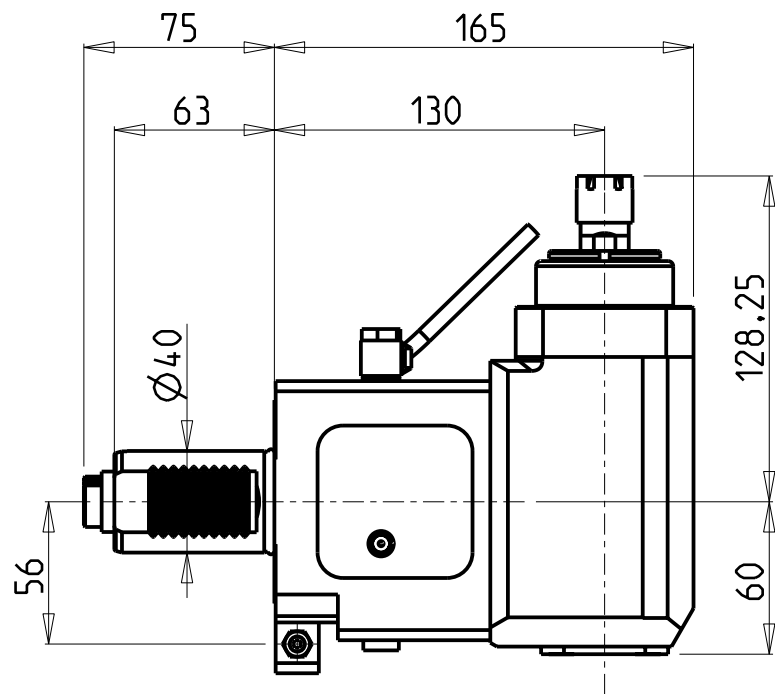

versione dx  
right version  
version rechts

versione sx  
left version  
version links

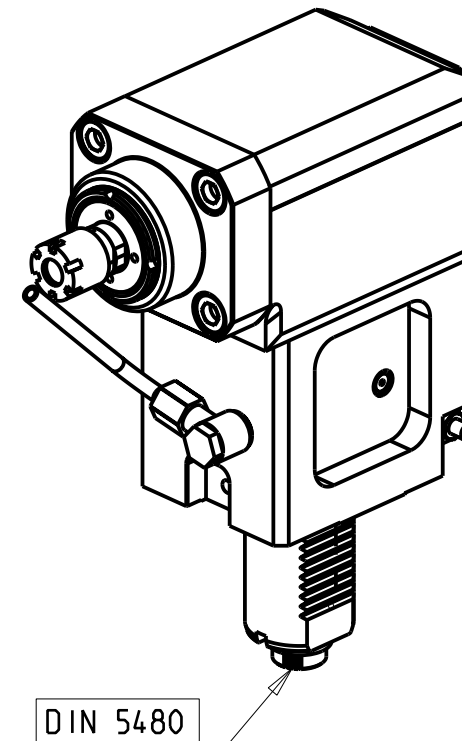
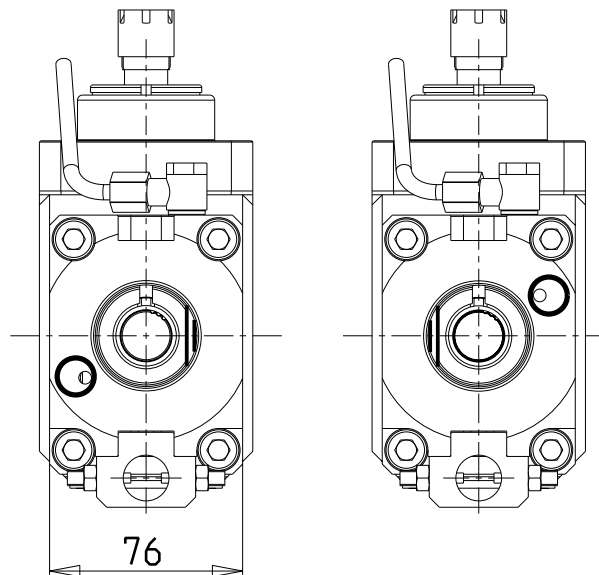

DIN 5480

Cod. MT		Mandrino Spindle Spindel	i	RPM	Coppia Max Max Torque Max Drehmoment	Lubrificazione est. Ext. coolant Aussenkuehlung	CHIAVI INCLUSE Keys included Schlüssel einbegriffen	
versione dx right version version rechts	versione sx left version version links						CHUB17	CHMNER16
SAU0600016	SAU0601016	ER16	1:3	18000	10Nm	X	CHUB17	CHMNER16

SAUTER  
VDI 40

MODULO MOTORIZZATO RADIALE MOLTIPLICATO I=1:3 VDI40 DIN 5480 H=130mm  
Radial geared-up I=1:3 driven tool VDI40 DIN 5480 H=130mm  
Radial angetriebenes Werkzeug uebersetzt I=1:3 VDI40 DIN 5480 H=130mm

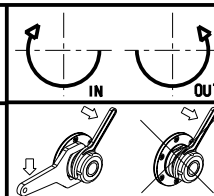

**M.T. srl**  
Via Casino Albini 480  
Tel. 0541/956034-957884  
Fax 0541/956341  
47842 S. GIOVANNI IN M. (RN)  
e-mail: mtma@mtmarchetti.com  
http://www.mtmarchetti.com

PRODUZIONE MODULI ROTANTI



PAGINA SAU018-3-24

Subject to change without notice.

10/2018

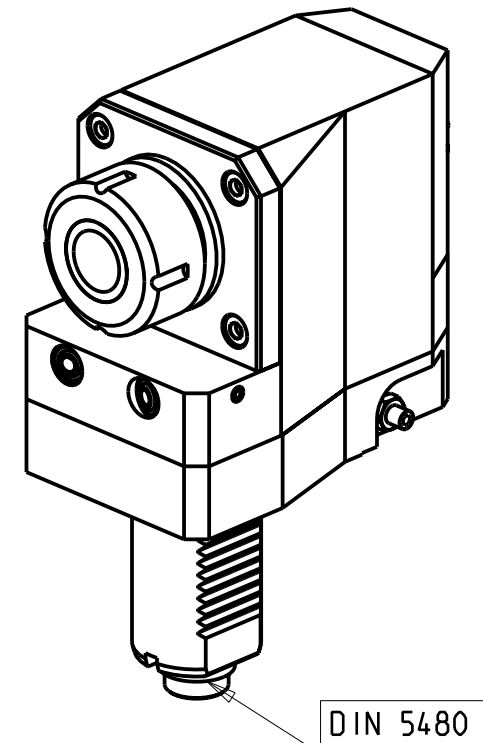
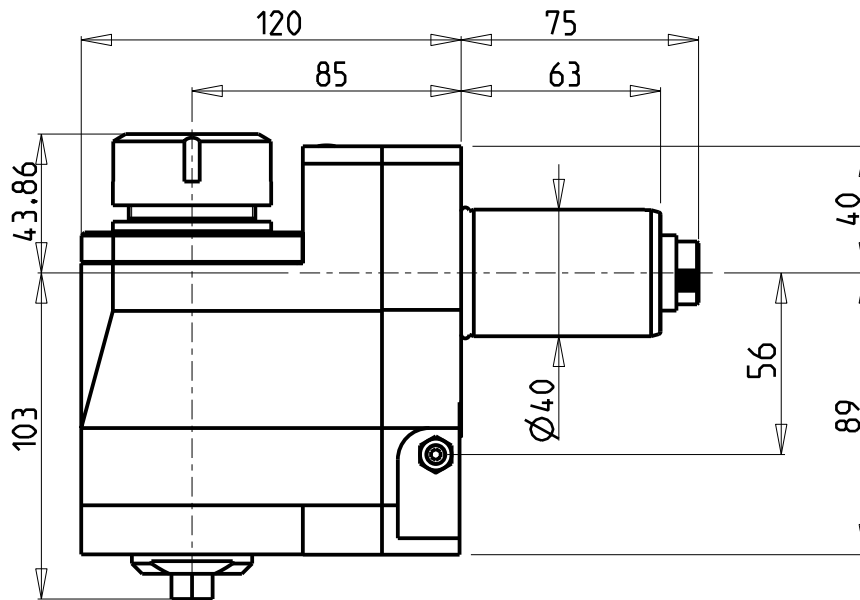
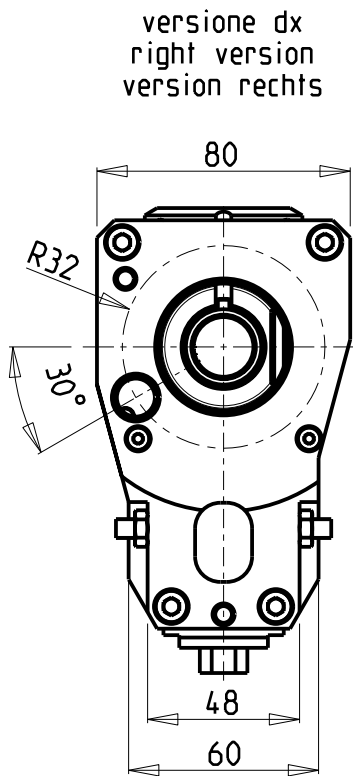

DIN 5480

Cod. MT	Mandrino Spindle Spindel	I	RPM	Coppia Max Max Torque Max Drehmoment	Lubrificazione est. Ext. coolant Aussenkuehlung	CHIAVI NON INCLUSE Keys not included Schluessel nicht einbegriffen	
SAU0060132	ER32	1:1	6000	70Nm	X	CHUB13	CHSTER32

SAUTER  
VDI 40

MODULO MOTORIZZATO RADIALE ARRETRATO VDI40 DIN 5480 H=85mm  
Radial rear-set driven tool VDI40 DIN 5480 H=85mm  
Radial angetriebenes Werkzeug zurueckversetzt VDI40 DIN 5480 H=85mm

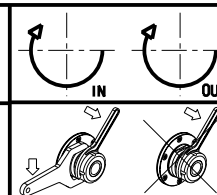

**M.T. srl**

Via Casino Albini 480  
Tel. 0541/956034-957884  
Fax 0541/956341  
47842 S. GIOVANNI IN M. (RN)  
e-mail: mtma@mtmarchetti.com  
http://www.mtmarchetti.com

PRODUZIONE MODULI ROTANTI



PAGINA SAU018-3-60

Subject to change without notice.

10/2018



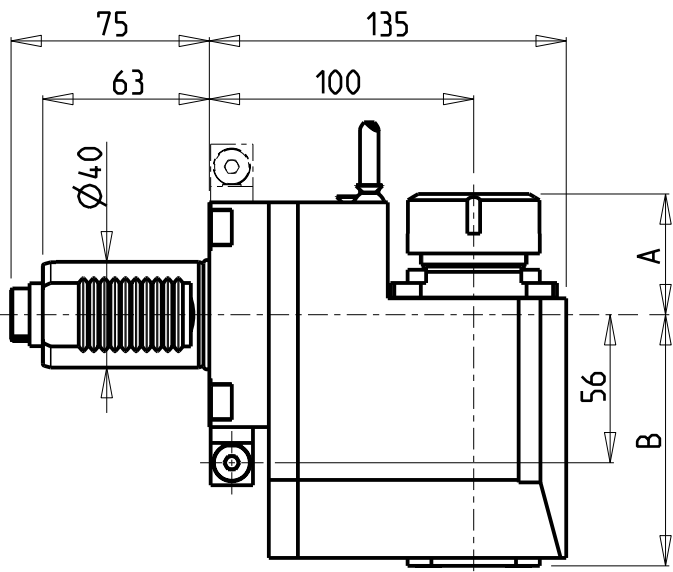

versione dx  
right version  
version rechts

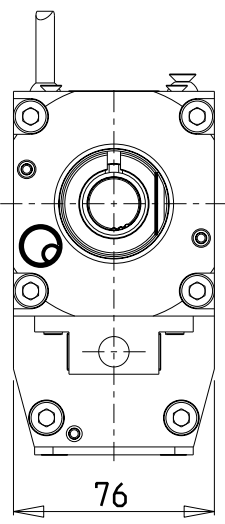

versione sx  
left version  
version links

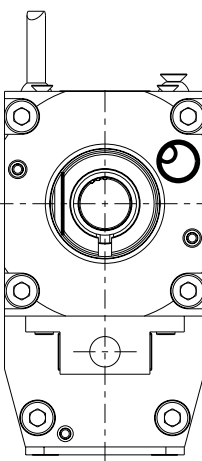

versione universale  
universal version  
universal version

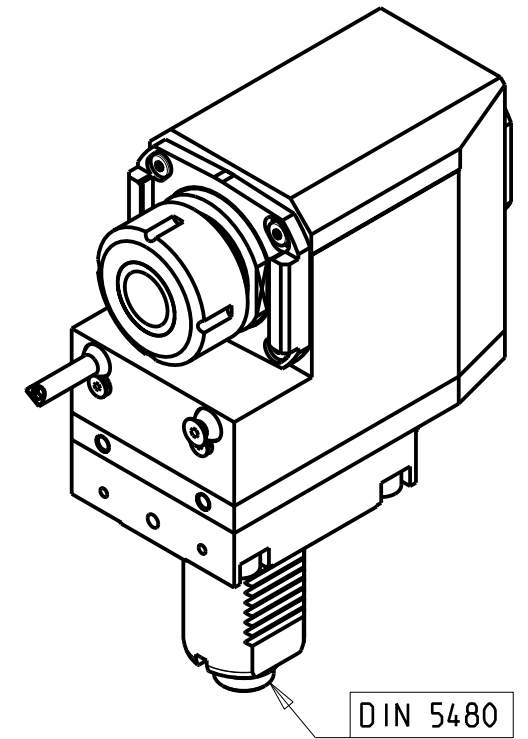
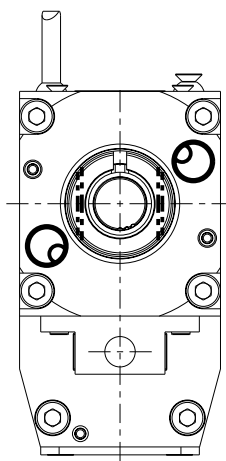

DIN 5480

Cod. MT			Mandrino Spindle Spindel	I	RPM	Coppia Max Max Torque Max Drehmoment	Lubrificazione int. Coolant through Innenkuehlung	Lubrificazione est. Ext. coolant Aussenkuehlung	A	B	CHIAVI NON INCLUDE Keys not included Schluessel nicht einbegriffen	
versione dx right version version rechts	versione sx left version version links	versione universale universal version universal version										
SAU0150125	SAU0151125	SAU0152125	ER25	1:1	6000	70Nm	-	X	42.66	95	CHSTER25	MNZ0410005 ▪
SAU0150225	SAU0151225	SAU0152225	ER25	1:1	6000	70Nm	P=70bar	X	42.66	108.5	CHSTER25	MNZ0410005 ▪
SAU0150132	SAU0151132	SAU0152132	ER32	1:1	6000	70Nm	-	X	45.66	95	CHSTER32	MNZ0410005 ▪
SAU0150232	SAU0151232	SAU0152232	ER32	1:1	6000	70Nm	P=70bar	X	45.66	108.5	CHSTER32	MNZ0410005 ▪

- Chiave inclusa
- Key included
- Schluessel inbegriffen

SAUTER  
VDI 40

MODULO MOTORIZZATO RADIALE ARRETRATO VDI40 DIN 5480 H=100mm  
Radial rear-set driven tool VDI40 DIN 5480 H=100mm  
Radial angetriebenes Werkzeug zurueckversetzt VDI40 DIN 5480 H=100mm

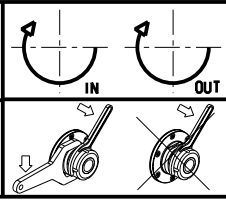

**M.T. srl**  
Via Casino Albini 480  
Tel. 0541/956034-957884  
Fax 0541/956341  
47842 S. GIOVANNI IN M. (RN)  
e-mail: mtma@mtmarchetti.com  
http://www.mtmarchetti.com

PRODUZIONE MODULI ROTANTI

PAGINA SAU018-3-70

Subject to change without notice.

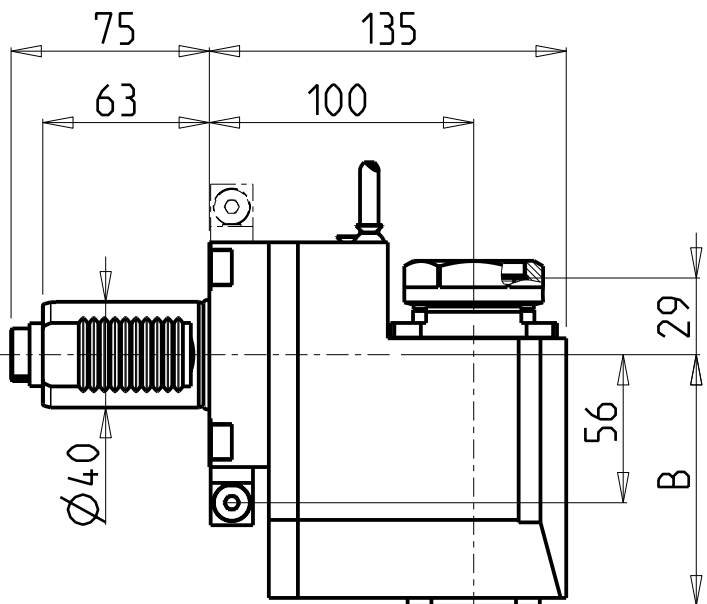

versione dx  
right version  
version rechts

versione sx  
left version  
version links

versione universale  
universal version  
universal version

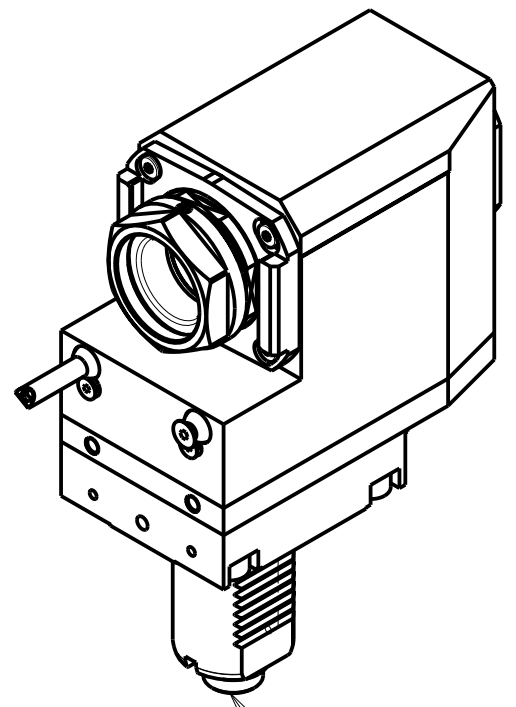
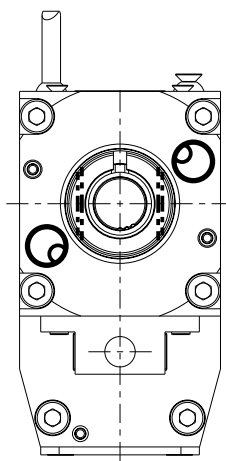
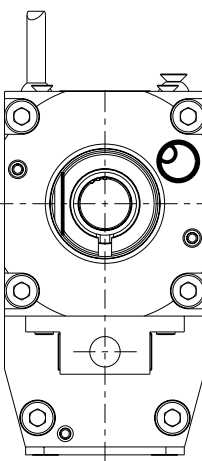
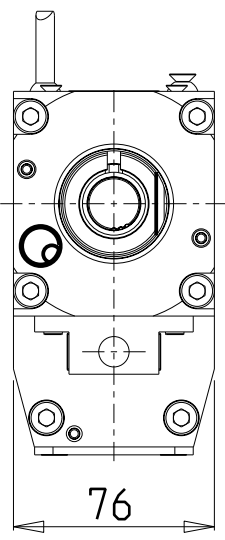

DIN 5480

PER PORTAUTENSILI MODULARI MTSK-40 VEDI PAG. TBL300-1-40  
 FOR MTSK-40 QUIK CHANGE TOOLHOLDERS CLAMPINGS SEE PAGE TBL300-1-40  
 FUER MTSK-40 MODULARE WERKZEUGAUFNAHMEN SIEHE SEITE TBL300-1-40

Cod. MT			Mandrino Spindle Spindel	I	RPM	Coppia Max Max Torque Max Drehmoment	Lubrificazione int. Coolant through Innenkuehlung	Lubrificazione est. Ext. coolant Aussenkuehlung	B	CHIAVI NON INCLUDE Keys not included Schlüssel nicht einbegriffen	
versione dx right version version rechts	versione sx left version version links	versione universale universal version universal version								CHUB46	MNZ0410005 *
SAU0710140	SAU0711140	SAU0712140	MTSK-40	1:1	6000	70Nm	-	X	95	CHUB46	MNZ0410005 *
SAU0710240	SAU0711240	SAU0712240	MTSK-40	1:1	6000	70Nm	P=70bar	X	108.5	CHUB46	MNZ0410005 *

- Chiave inclusa
- Key included
- Schlüssel einbegriffen

SAUTER  
VDI 40

MODULO MOTORIZZATO RADIALE ARRETRATO MTSK VDI40 DIN 5480 H=100mm  
 Radial MTSK rear-set driven tool VDI40 DIN 5480 H=100mm  
 Radial MTSK angetriebenes Werkzeug zurueckversetzt VDI40 DIN 5480 H=100mm

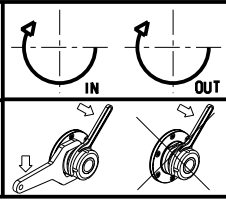

**M.T. srl**  
 Via Casino Albini 480  
 Tel. 0541/956034-957884  
 Fax 0541/956341  
 47842 S. GIOVANNI IN M. (RN)  
 e-mail: mtma@mtmarchetti.com  
 http://www.mtmarchetti.com

PRODUZIONE MODULI ROTANTI

PAGINA SAU018-3-70-K

Subject to change without notice.

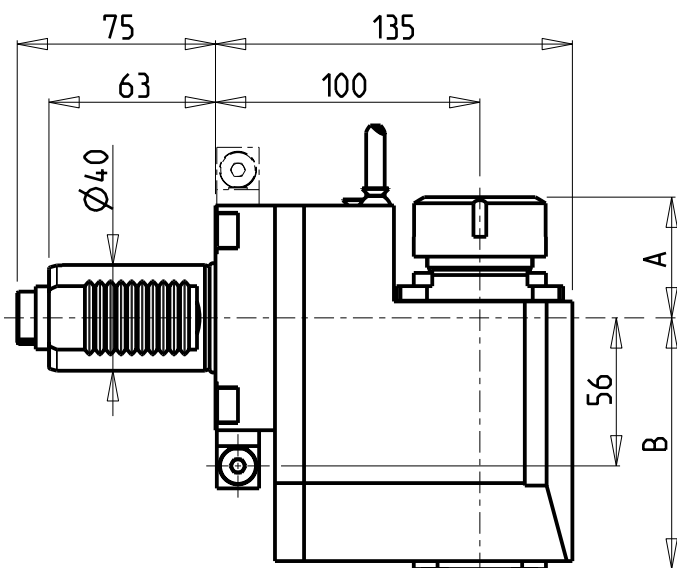

versione dx  
right version  
version rechts

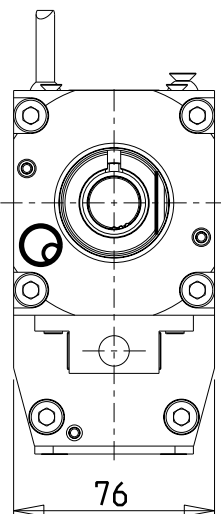

versione sx  
left version  
version links

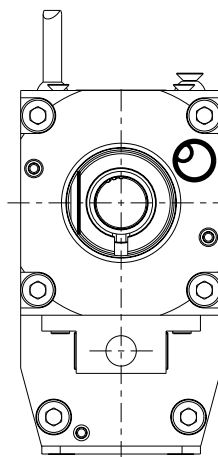

versione universale  
universal version  
universal version

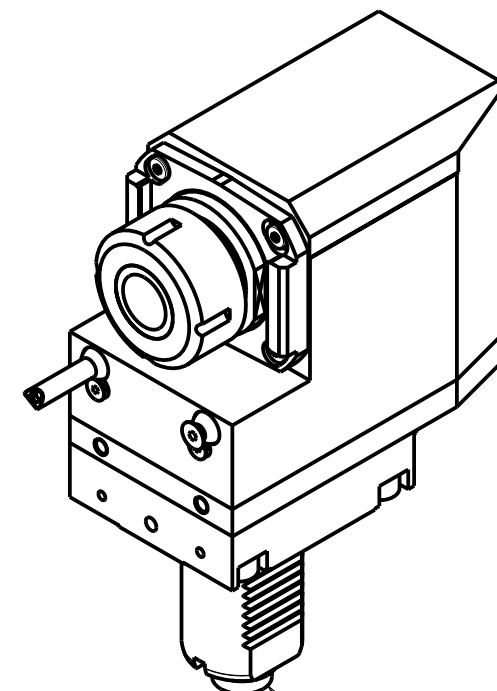
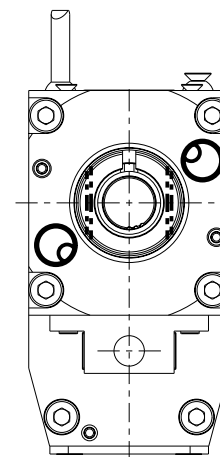

DIN 5480

Cod. MT			Mandrino Spindle Spindel	I	RPM	Coppia Max Max Torque Max Drehmoment	Lubrificazione int. Coolant through Innenkuehlung	Lubrificazione est. Ext. coolant Aussenkuehlung	A	B	CHIAVI NON INCLUSE Keys not included Schluessel nicht einbegriffen	
versione dx right version version rechts	versione sx left version version links	versione universale universal version universal version										
SAU0150325	SAU0151325	SAU0152325	ER25	2:1	3000	90Nm	-	X	42.66	95	CHSTER25	MNZ0410005 ▪
SAU0150425	SAU0151425	SAU0152425	ER25	2:1	3000	90Nm	P=70bar	X	42.66	108.5	CHSTER25	MNZ0410005 ▪
SAU0150332	SAU0151332	SAU0152332	ER32	2:1	3000	90Nm	-	X	45.66	95	CHSTER32	MNZ0410005 ▪
SAU0150432	SAU0151432	SAU0152432	ER32	2:1	3000	90Nm	P=70bar	X	45.66	108.5	CHSTER32	MNZ0410005 ▪

- Chiave inclusa
- Key included
- Schluessel inbegriffen

SAUTER  
VDI 40

MODULO MOTORIZZATO RADIALE ARRETRATO RIDOTTO I=2:1 VDI40 DIN 5480  
Radial geared-down I=2:1 rear-set driven tool VDI40 DIN 5480  
Radial angetriebenes Werkzeug zurueckversetzt untersetzt I=2:1 VDI40 DIN 5480

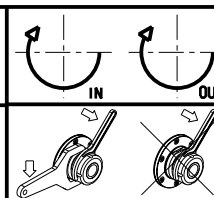

**M.T. srl**  
Via Casino Albini 480  
Tel. 0541/956034-957884  
Fax 0541/956341  
47842 S. GIOVANNI IN M. (RN)  
e-mail: mtma@mtmarchetti.com  
http://www.mtmarchetti.com

PRODUZIONE MODULI ROTANTI



PAGINA SAU018-3-71

Subject to change without notice.

10/2018

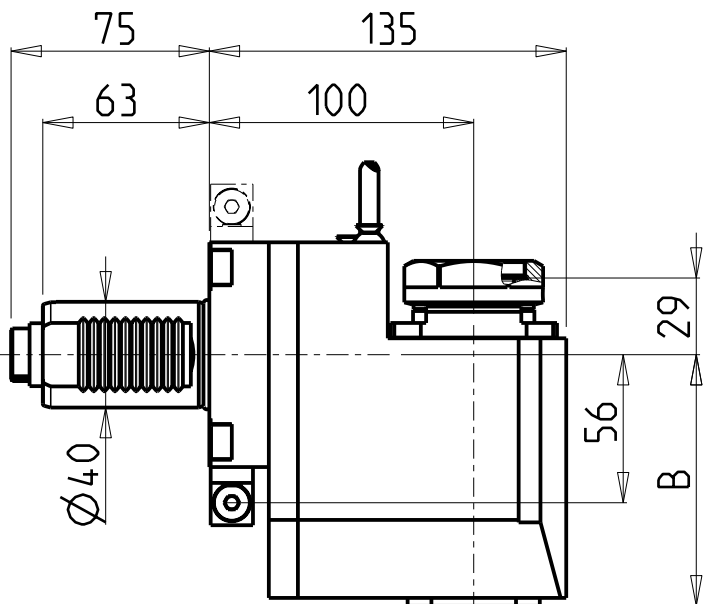

versione dx  
right version  
version rechts

versione sx  
left version  
version links

versione universale  
universal version  
universal version

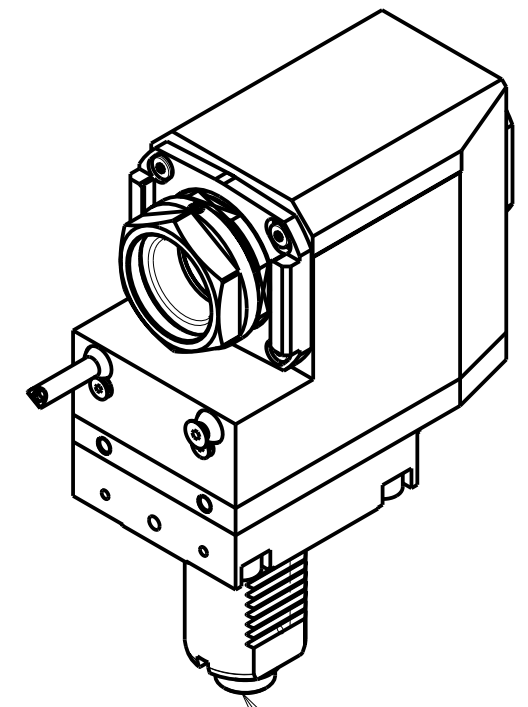
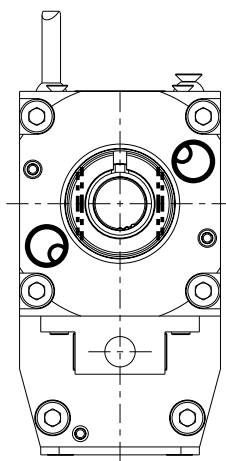
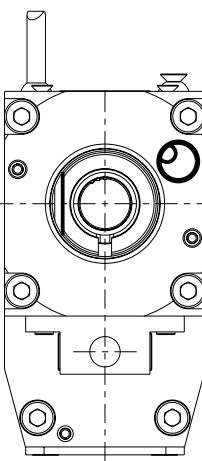
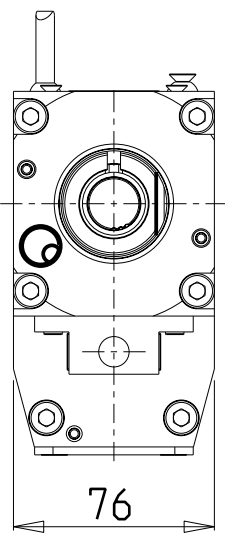

DIN 5480

PER PORTAUTENSILI MODULARI MTSK-40 VEDI PAG. TBL300-1-40  
 FOR MTSK-40 QUIK CHANGE TOOLHOLDERS CLAMPINGS SEE PAGE TBL300-1-40  
 FUER MTSK-40 MODULARE WERKZEUGAUFNAHMEN SIEHE SEITE TBL300-1-40

Cod. MT			Mandrino Spindle Spindel	I	RPM	Coppia Max Max Torque Max Drehmoment	Lubrificazione int. Coolant through Innenkuehlung	Lubrificazione est. Ext. coolant Aussenkuehlung	B	CHIAVI NON INCLUDE Keys not included Schluessel nicht einbegriffen	
versione dx right version version rechts	versione sx left version version links	versione universale universal version universal version								CHUB46	MNZ0410005 *
SAU0710340	SAU0711340	SAU0712340	MTSK-40	2:1	3000	90Nm	-	X	95	CHUB46	MNZ0410005 *
SAU0710440	SAU0711440	SAU0712440	MTSK-40	2:1	3000	90Nm	P=70bar	X	108.5	CHUB46	MNZ0410005 *

- Chiave inclusa
- Key included
- Schluessel inbegriffen

SAUTER  
VDI 40

MODULO MOTORIZZATO RADIALE ARRETRATO MTSK RIDOTTO I=2:1 VDI40 DIN 5480  
 Radial MTSK geared-down I=2:1 rear-set driven tool VDI40 DIN 5480  
 Radial MTSK angetriebenes Werkzeug zurueckversetzt untersetzt I=2:1 VDI40 DIN 5480

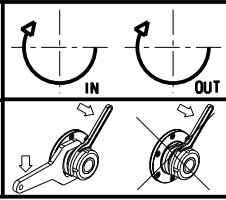

**M.T. srl**  
 Via Casino Albini 480  
 Tel. 0541/956034-957884  
 Fax 0541/956341  
 47842 S. GIOVANNI IN M. (RN)  
 e-mail: mtma@mtmarchetti.com  
 http://www.mtmarchetti.com

PRODUZIONE MODULI ROTANTI

PAGINA SAU018-3-71-K

Subject to change without notice.

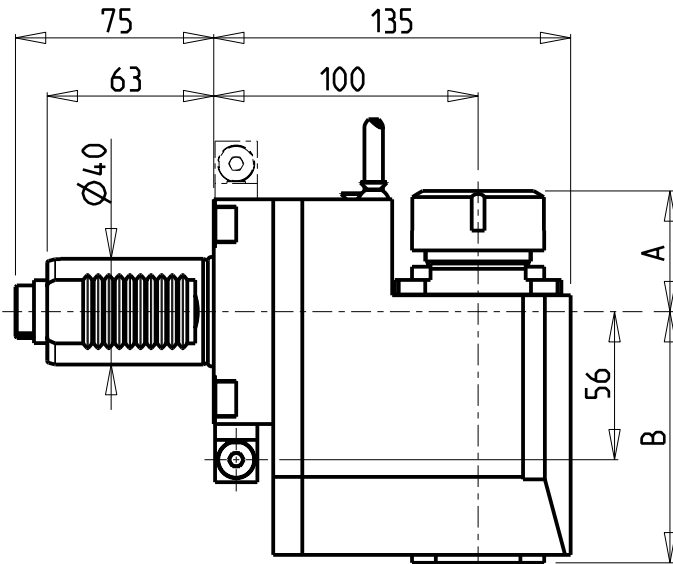

versione dx  
right version  
version rechts

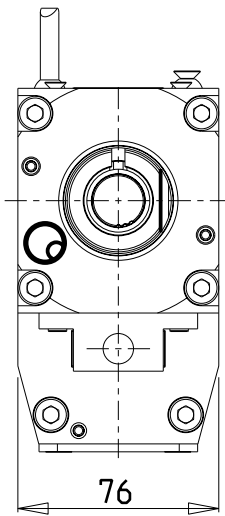

versione sx  
left version  
version links

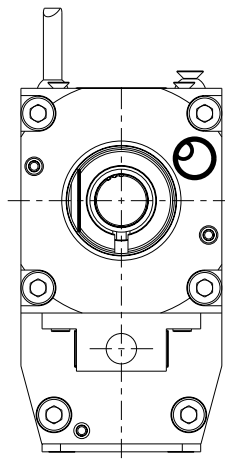

versione universale  
universal version  
universal version

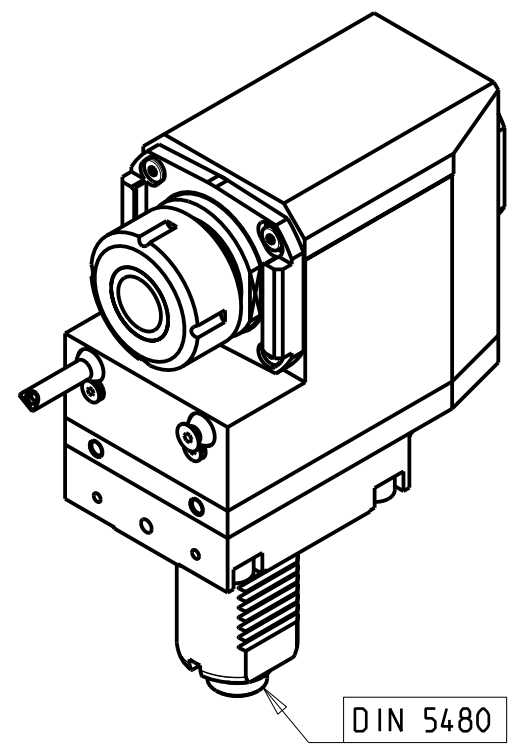
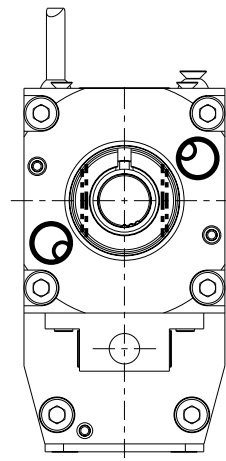

DIN 5480

Cod. MT			Mandrino Spindle Spindel	I	RPM	Coppia Max Max Torque Max Drehmoment	Lubrificazione int. Coolant through Innenkuehlung	Lubrificazione est. Ext. coolant Aussenkuehlung	A	B	CHIAVI NON INCLUDE Keys not included Schluessel nicht einbegriffen	
versione dx right version version rechts	versione sx left version version links	versione universale universal version universal version										
SAU0150525	SAU0151525	SAU0152525	ER25	1:2	12000	40Nm	-	X	42.66	95	CHSTER25	MNZ0410005
SAU0150625	SAU0151625	SAU0152625	ER25	1:2	12000	40Nm	P=70bar	X	42.66	108.5	CHSTER25	MNZ0410005
SAU0150532	SAU0151532	SAU0152532	ER32	1:2	12000	40Nm	-	X	45.66	95	CHSTER32	MNZ0410005
SAU0150632	SAU0151632	SAU0152632	ER32	1:2	12000	40Nm	P=70bar	X	45.66	108.5	CHSTER32	MNZ0410005

- Chiave inclusa
- Key included
- Schluessel inbegriffen

SAUTER  
VDI 40

MODULO MOTORIZZATO RADIALE ARRETRATO MOLTIPLICATO I=1:2 VDI40 DIN 5480  
Radial geared-up I=1:2 rear-set driven tool VDI40 DIN 5480  
Radial angetriebenes Werkzeug zurueckversetzt uebersetzt I=1:2 VDI40 DIN 5480

Subject to change without notice.

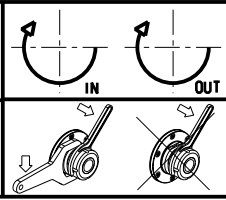

**M.T. srl**  
Via Casino Albini 480  
Tel. 0541/956034-957884  
Fax 0541/956341  
47842 S. GIOVANNI IN M. (RN)  
e-mail: mtma@mtmarchetti.com  
http://www.mtmarchetti.com

PRODUZIONE MODULI ROTANTI



PAGINA SAU018-3-72

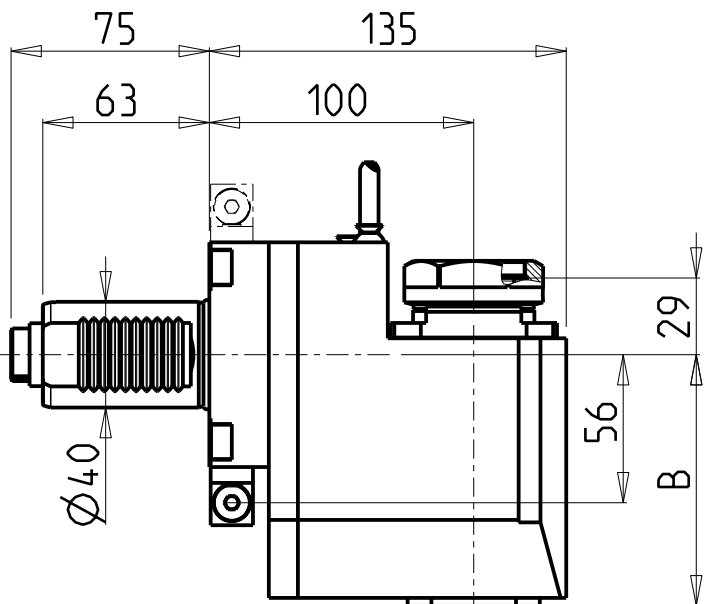

versione dx  
right version  
version rechts

versione sx  
left version  
version links

versione universale  
universal version  
universal version

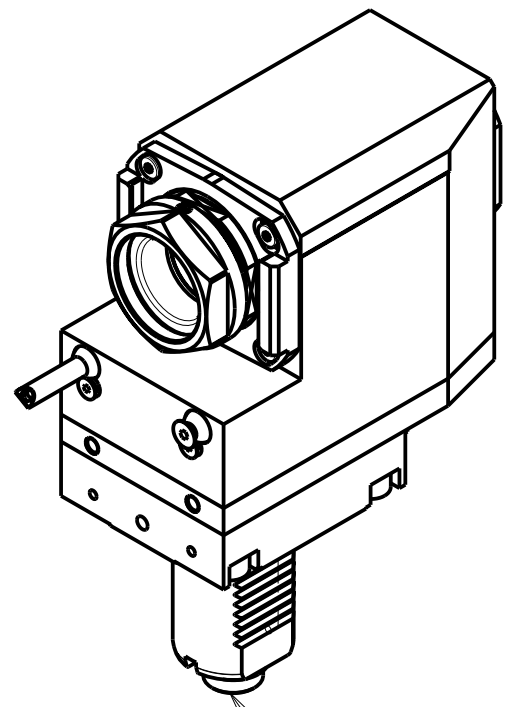
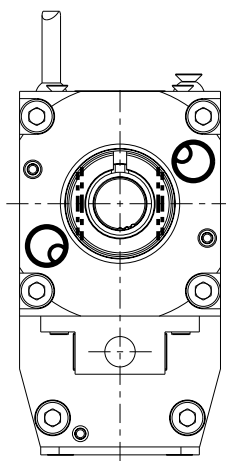
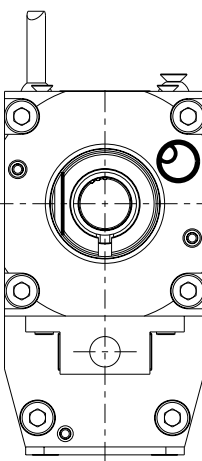
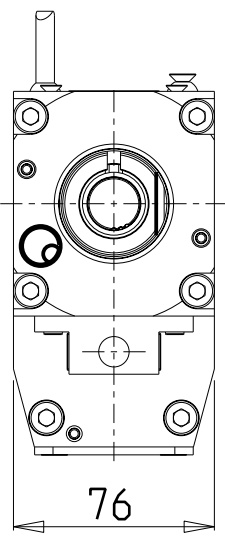

DIN 5480

PER PORTAUTENSILI MODULARI MTSK-40 VEDI PAG. TBL300-1-40  
FOR MTSK-40 QUIK CHANGE TOOLHOLDERS CLAMPINGS SEE PAGE TBL300-1-40  
FUER MTSK-40 MODULARE WERKZEUGAUFNAHMEN SIEHE SEITE TBL300-1-40

Cod. MT			Mandrino Spindle Spindel	I	RPM	Coppia Max Max Torque Max Drehmoment	Lubrificazione int. Coolant through Innenkuehlung	Lubrificazione est. Ext. coolant Aussenkuehlung	B	CHIAVI NON INCLUSE Keys not included Schlüssel nicht einbegriffen	
versione dx right version version rechts	versione sx left version version links	versione universale universal version universal version								CHUB46	MNZO4 10005 *
SAU0710540	SAU0711540	SAU0712540	MTSK-40	1:2	12000	40Nm	-	X	95	CHUB46	MNZO4 10005 *
SAU0710640	SAU0711640	SAU0712640	MTSK-40	1:2	12000	40Nm	P=70bar	X	108.5	CHUB46	MNZO4 10005 *

- Chiave inclusa
- Key included
- Schlüssel inbegriffen

SAUTER  
VDI 40

MODULO MOTORIZZATO RADIALE ARRETRATO MTSK MOLTIPLICATO I=1:2 VDI40 DIN 5480  
Radial MTSK geared-up I=1:2 rear-set driven tool VDI40 DIN 5480  
Radial MTSK angetriebenes Werkzeug zurueckversetzt uebersetzt I=1:2 VDI40 DIN 5480

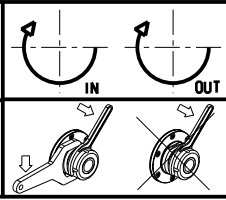

**M.T. srl**  
Via Casino Albini 480  
Tel. 0541/956034-957884  
Fax 0541/956341  
47842 S. GIOVANNI IN M. (RN)  
e-mail: mtma@mtmarchetti.com  
http://www.mtmarchetti.com

PRODUZIONE MODULI ROTANTI



PAGINA SAU018-3-72-K

Subject to change without notice.

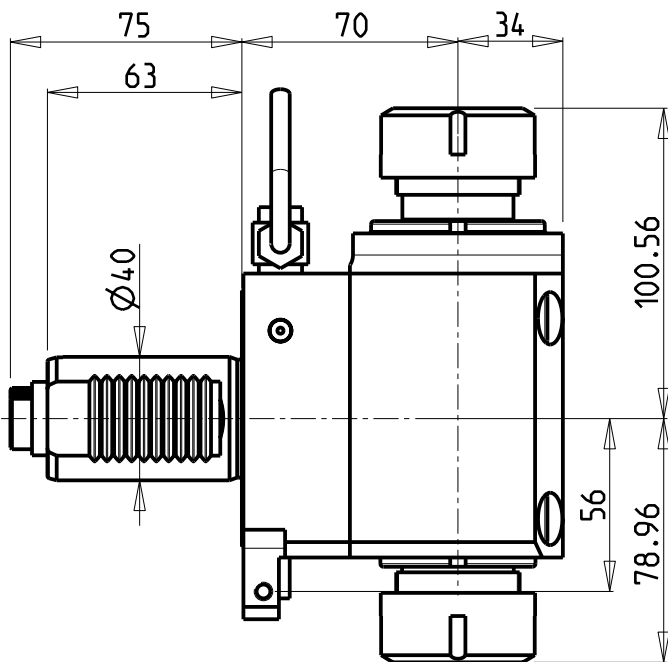

versione dx  
right version  
version rechts

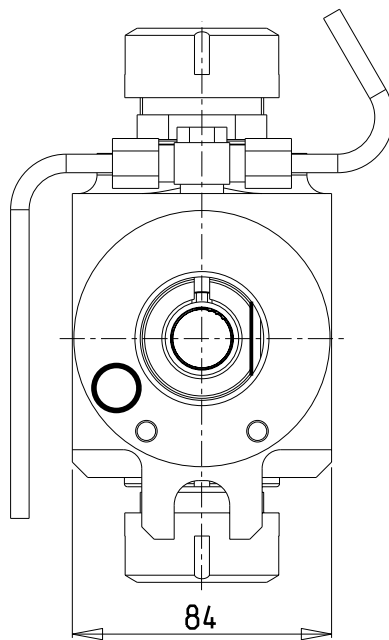

versione sx  
left version  
version links

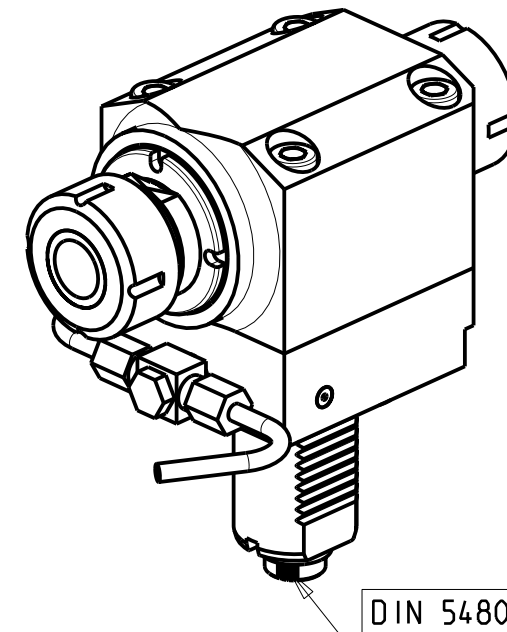
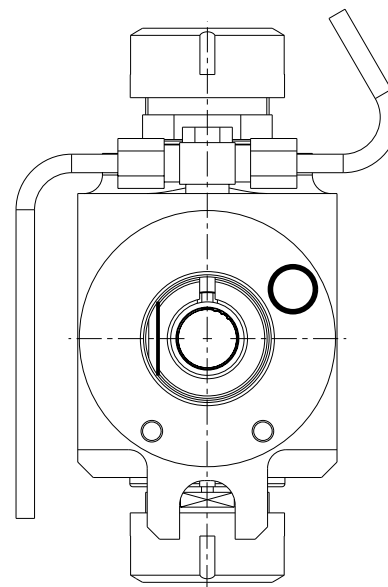

**ATTENZIONE - ATTENTION - ACHTUNG**

- Per lo smontaggio degli utensili utilizzare sempre la chiave di contrasto come indicato nel manuale d'uso.
- For disassembly of the tools use always the contrast key as mentioned in the user instructions.
- Fuer das Abmontieren der Werkzeuge immer den Gegenschlüssel benutzen wie in der Bedienungsanleitung erwäehnt.

Cod. MT		Mandrino Spindle Spindel	I	RPM	Coppia Max Max Torque Max Drehmoment	Lubrificazione est. Ext. coolant Aussenkuehlung	CHIAVI NON INCLUSE Keys not included Schlüssel nicht einbegriffen	
versione dx right version version rechts	versione sx left version version links						CHUB36	CHSTER32
216SAU_A32_40D00	216SAU_A32_40D10	ER32+ER32	1:1	6000	70Nm	X	CHUB36	CHSTER32

SAUTER  
VDI 40

MODULO MOTORIZZATO RADIALE BISPORGENTE VDI40 DIN 5480 H=70mm  
Radial opposite face twin driven tool VDI40 DIN 5480 H=70mm  
Radial angetriebenes Werkzeug halb vorspringend VDI40 DIN 5480 H=70mm

**M.T. srl**

Via Casino Albini 480  
Tel. 0541/956034-957884  
Fax 0541/956341  
47842 S. GIOVANNI IN M. (RN)  
e-mail: mtma@mtmarchetti.com  
http://www.mtmarchetti.com

PRODUZIONE MODULI ROTANTI



PAGINA SAU019-3-00

Subject to change without notice.

10/2018

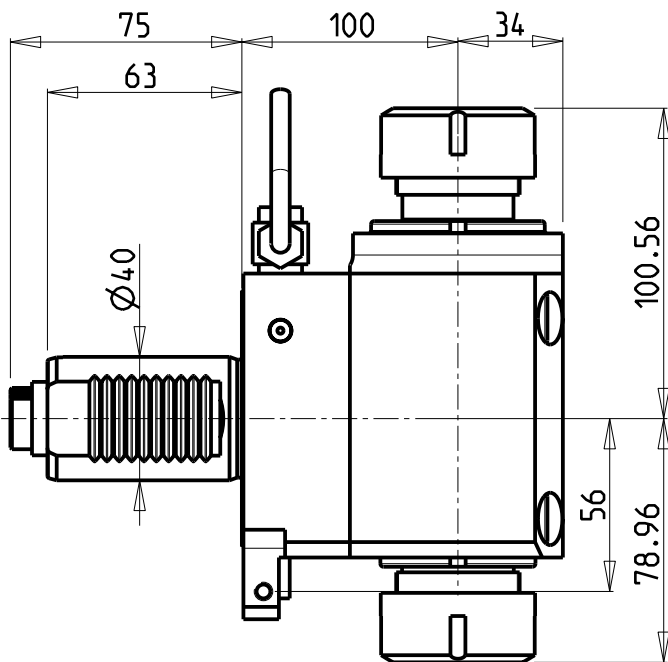

versione dx  
right version  
version rechts

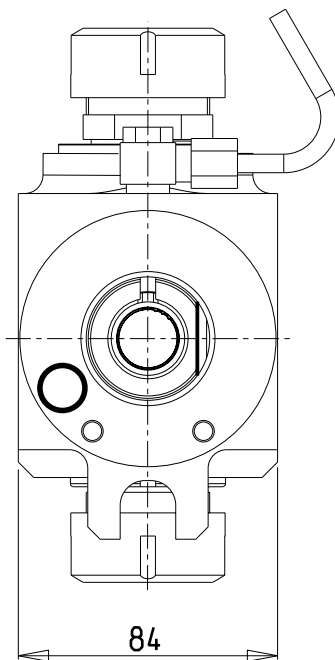

versione sx  
left version  
version links

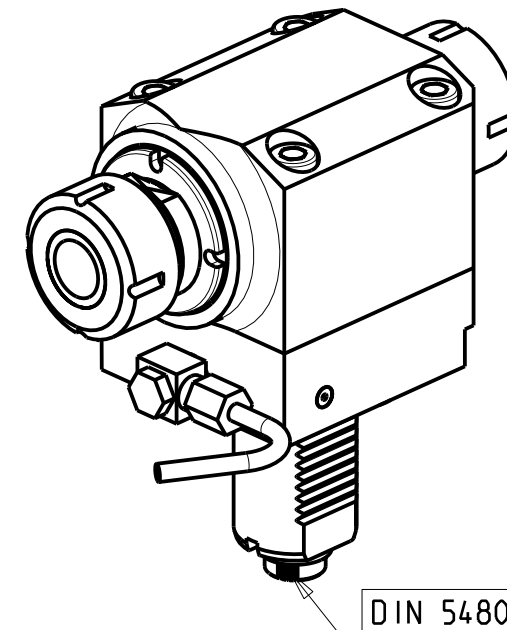
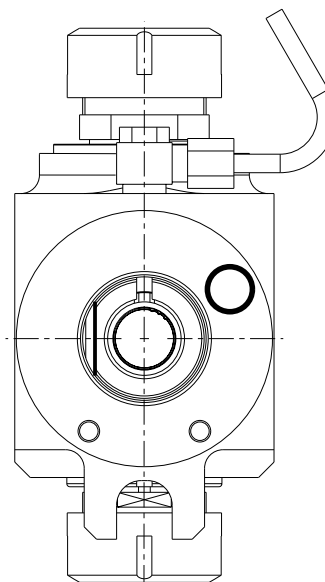

ATTENZIONE - ATTENTION - ACHTUNG

- Per lo smontaggio degli utensili utilizzare sempre la chiave di contrasto come indicato nel manuale d'uso.
- For disassembly of the tools use always the contrast key as mentioned in the user instructions.
- Fuer das Abmontieren der Werkzeuge immer den Gegenschlüssel benutzen wie in der Bedienungsanleitung erwäehnt.

Cod. MT		Mandrino Spindle Spindel	I	RPM	Coppia Max Max Torque Max Drehmoment	Lubrificazione est. Ext. coolant Aussenkuehlung	CHIAVI NON INCLUSE Keys not included Schluesssel nicht einbegriffen	
versione dx right version version rechts	versione sx left version version links						CHUB36	CHSTER32
SAU0030232	-	ER32+ER32	1:1	6000	70Nm	X	CHUB36	CHSTER32

SAUER  
VDI 40

MODULO MOTORIZZATO RADIALE BISPORGENTE VDI40 DIN 5480 H=100mm  
Radial opposite face twin driven tool VDI40 DIN 5480 H=100mm  
Radial angetriebenes Werkzeug halb vorspringend VDI40 DIN 5480 H=100mm

Subject to change without notice.

**M.T. srl**

Via Casino Albini 480  
Tel. 0541/956034-957884  
Fax 0541/956341  
47842 S. GIOVANNI IN M. (RN)  
e-mail: mtma@mtmarchetti.com  
http://www.mtmarchetti.com

PRODUZIONE MODULI ROTANTI



PAGINA SAU019-3-10



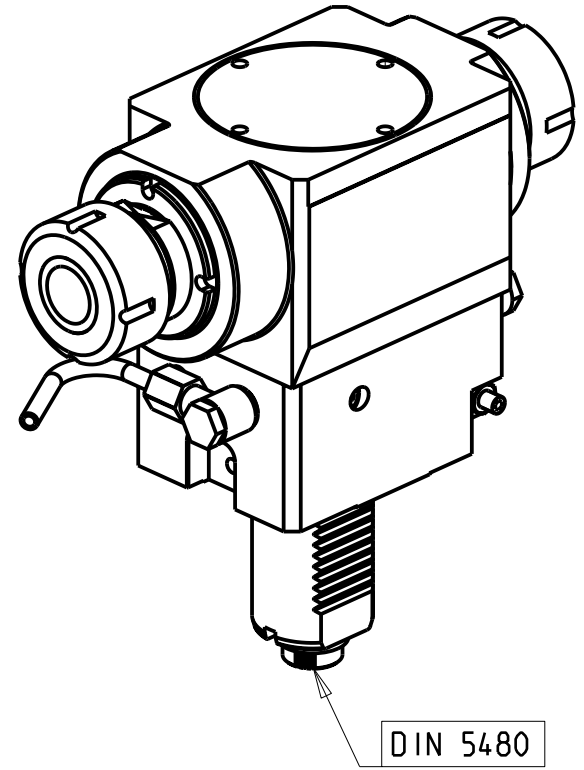
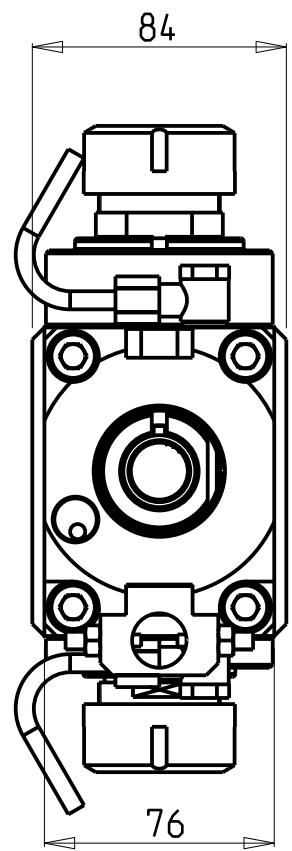
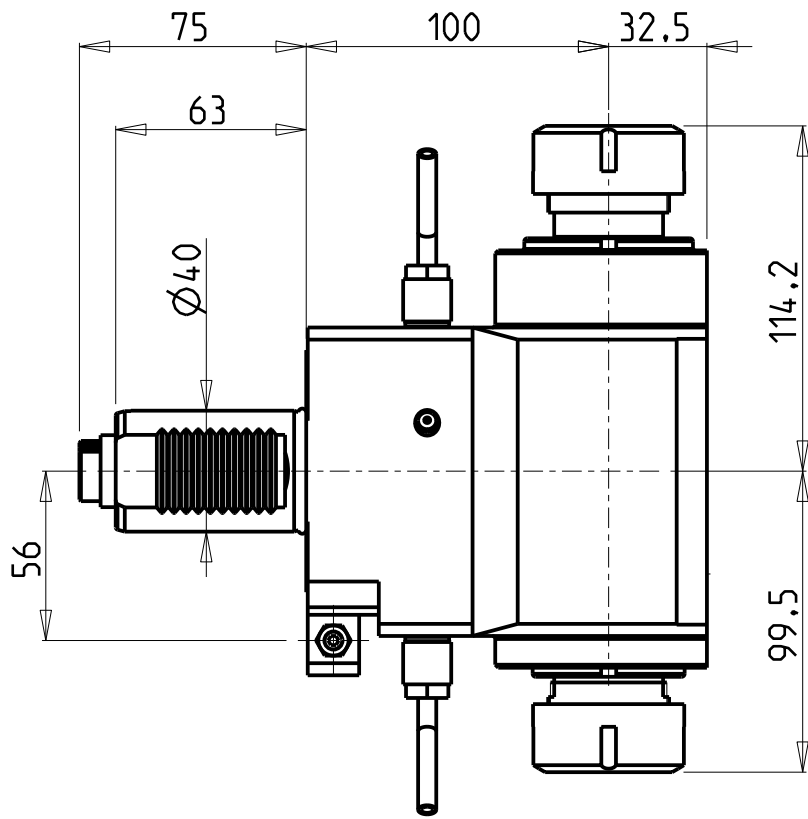

**ATTENZIONE - ATTENTION - ACHTUNG**

- Per lo smontaggio degli utensili utilizzare sempre la chiave di contrasto come indicato nel manuale d'uso.
- For disassembly of the tools use always the contrast key as mentioned in the user instructions.
- Fuer das Abmontieren der Werkzeuge immer den Gegenschlüssel benutzen wie in der Bedienungsanleitung erwäehnt.

Cod. MT	Mandrino Spindle Spindel	I	RPM	Coppia Max Max Torque Max Drehmoment	Lubrificazione est. Ext. coolant Aussenkuehlung	CHIAVI NON INCLUSE Keys not included Schluessel nicht einbegriffen	
SAU0540232	ER32+ER32	1:2	12000	40Nm	X	CHUB36	CHSTER32

**SAUTER**  
**VDI 40**

MODULO MOTORIZZATO RADIALE BISPORGENTE MOLTIPLICATO I=1:2 VDI40 DIN 5480  
Radial geared-up I=1:2 opposite face twin driven tool VDI40 DIN 5480  
Radial angetriebenes Werkzeug halb vorspringend uebersetzt I=1:2 VDI40 DIN 5480

Subject to change without notice.

**M.T. srl**  
Via Casino Albini 480  
Tel. 0541/956034-957884  
Fax 0541/956341  
47842 S. GIOVANNI IN M. (RN)  
e-mail: mtma@mtmarchetti.com  
<http://www.mtmarchetti.com>

PRODUZIONE MODULI ROTANTI



PAGINA SAU019-3-13

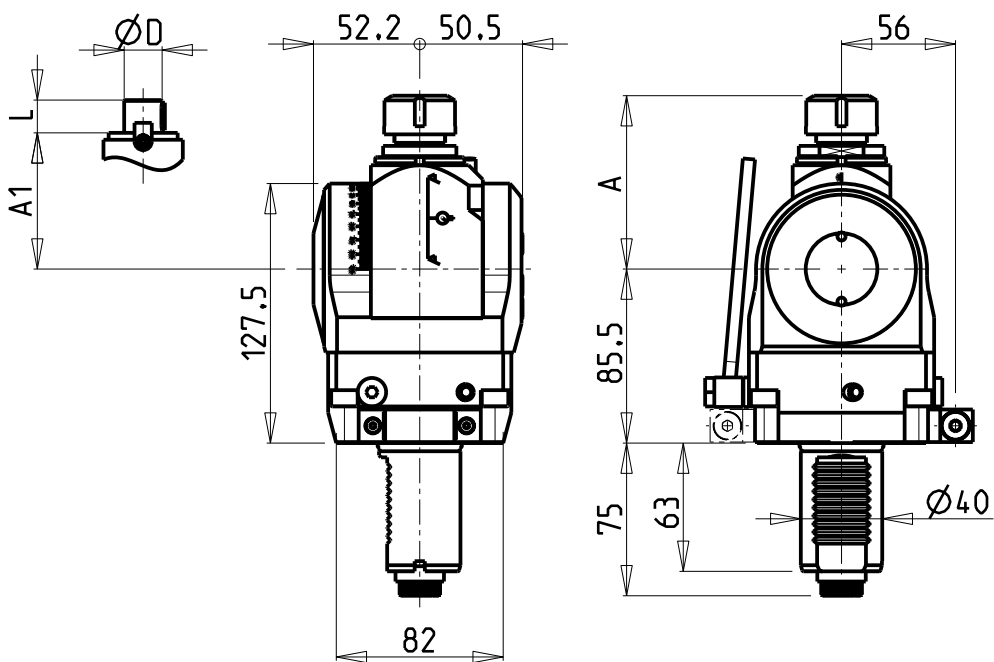

versione dx  
right version  
version rechts

versione sx  
left version  
version links

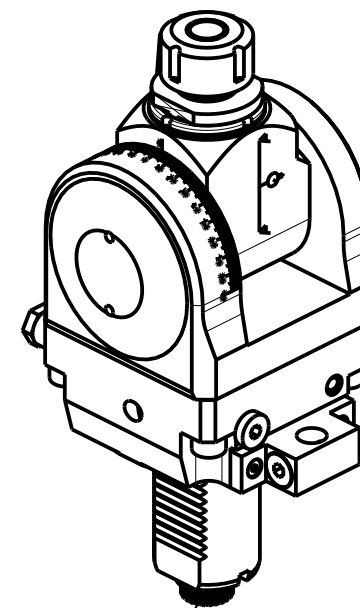
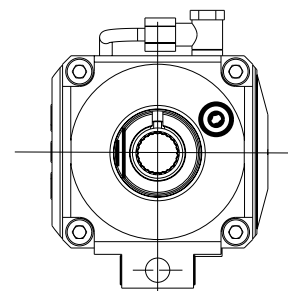
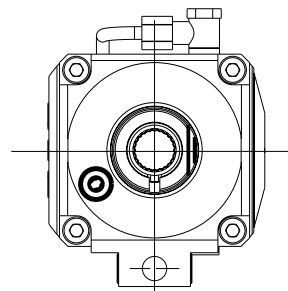

DIN 5480

Cod. MT		Mandrino Spindle Spindel	I	RPM	Coppia Max Max Torque Max Drehmoment	Lubrificazione est. Ext. coolant Aussehenkuehlung	A	A1	D	L	CHIAVI INCLUSE Keys included Schlüssel einbegriffen	
versione dx right version version rechts	versione sx left version version links										CHUB36	CHSTER
SAU0860120	SAU0861120	ER20	1:1	6000	40Nm	X	85.16	-	-	-	CHUB36	CHSTER20
SAU0860125	SAU0861125	ER25	1:1	6000	40Nm	X	86.16	-	-	-	CHUB36	CHSTER25
SAU0860516	SAU0861516	Ø16x17	1:1	6000	40Nm	X	-	65	16	17	CHUB36	CH_VTCROCE_M08
SAU0860522	SAU0861522	Ø22x19	1:1	6000	40Nm	X	-	66	22	19	CHUB36	CH_VTCROCE_M10
SAU0860519	SAU0861519	Ø3/4"x3/4"	1:1	6000	40Nm	X	-	65	3/4"	3/4"	CHUB36	CH_VTCROCE_M08

SAUTER  
VDI 40

MODULO MOTORIZZATO ORIENTABILE ±90° VDI40 DIN 5480  
±90° adjustable angle driven tool VDI40 DIN 5480  
Angetriebenes Werkzeug schwenkbar ±90° VDI40 DIN 5480

Subject to change without notice.

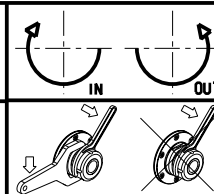

**M.T. srl**

Via Casino Albini 480  
Tel. 0541/956034-957884  
Fax 0541/956341  
47842 S. GIOVANNI IN M. (RN)  
e-mail: mtma@mtmarchetti.com  
http://www.mtmarchetti.com

PRODUZIONE MODULI ROTANTI



PAGINA SAU019-3-60

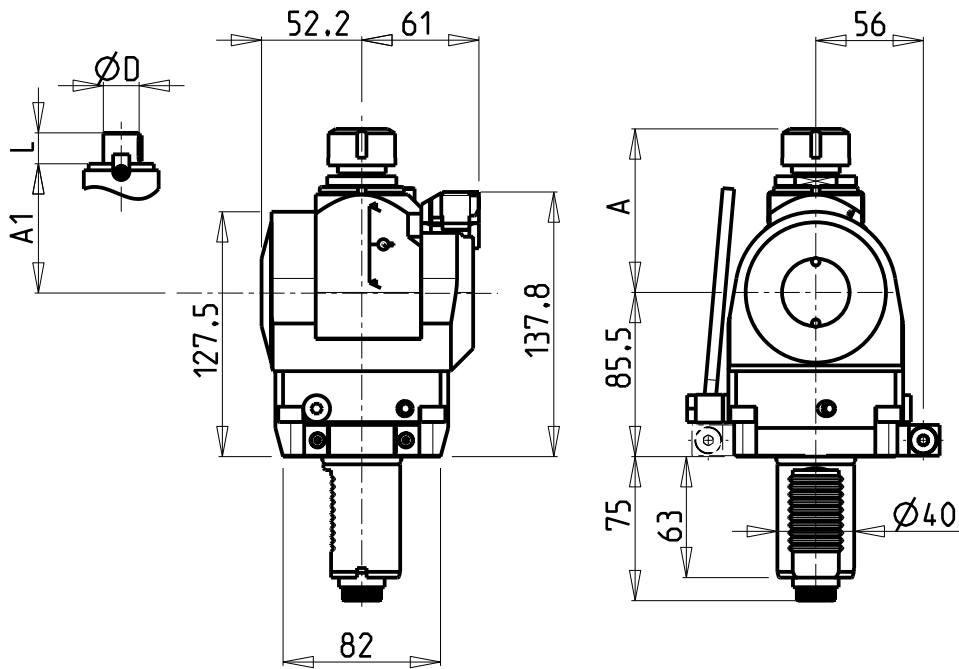

versione dx  
right version  
version rechts

versione sx  
left version  
version links

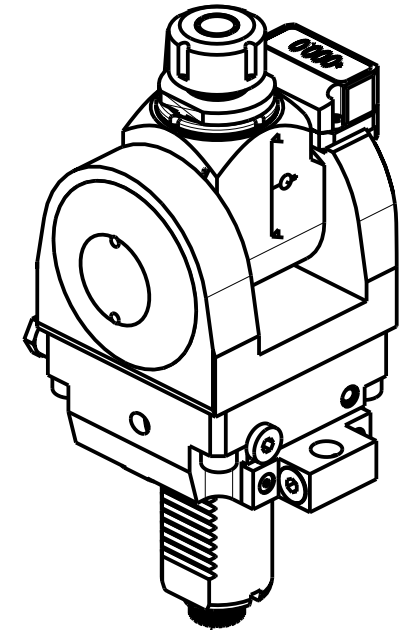
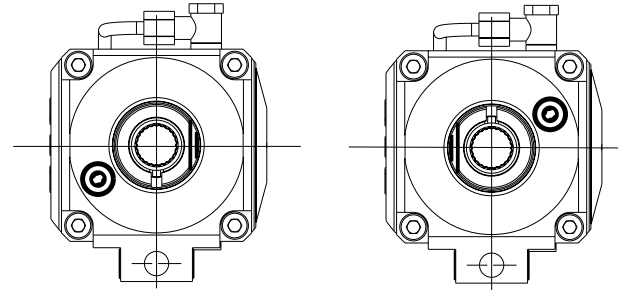

DIN 5480

Cod. MT		Mandrino Spindle Spindel	I	RPM	Coppia Max Max Torque Max Drehmoment	Lubrificazione est. Ext. coolant Aussehenkuehlung	A	A1	D	L	CHIAVI INCLUSE Keys included Schlüssel einbegriffen	
versione dx right version version rechts	versione sx left version version links											
SAU0800120	SAU0801120	ER20	1:1	6000	40Nm	X	85.16	-	-	-	CHUB36	CHSTER20
SAU0800125	SAU0801125	ER25	1:1	6000	40Nm	X	86.16	-	-	-	CHUB36	CHSTER25
SAU0800516	SAU0801516	Ø16x17	1:1	6000	40Nm	X	-	65	16	17	CHUB36	CH_VTCROCE_M08
SAU0800522	SAU0801522	Ø22x19	1:1	6000	40Nm	X	-	66	22	19	CHUB36	CH_VTCROCE_M10
SAU0800519	SAU0801519	Ø3/4"x3/4"	1:1	6000	40Nm	X	-	65	3/4"	3/4"	CHUB36	CH_VTCROCE_M08

SAUTER  
VDI 40

MODULO MOTORIZZATO ORIENTABILE ±90° CON NONIO DIGITALE VDI40 DIN 5480  
±90° adjustable angle driven tool with digital display VDI40 DIN 5480  
Angetriebenes Werkzeug schwenkbar ±90° mit digital display VDI40 DIN 5480

Subject to change without notice.

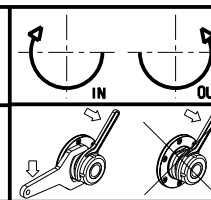

**M.T. srl**

Via Casino Albini 480  
Tel. 0541/956034-957884  
Fax 0541/956341  
47842 S. GIOVANNI IN M. (RN)  
e-mail: mtma@mtmarchetti.com  
http://www.mtmarchetti.com

PRODUZIONE MODULI ROTANTI



PAGINA SAU019-3-61

**ATTENZIONE - ATTENTION - ACHTUNG**

- Per lo smontaggio degli utensili utilizzare sempre la chiave di contrasto come indicato nel manuale d'uso.
- For disassembly of the tools use always the contrast key as mentioned in the user instructions.
- Fuer das Abmontieren der Werkzeuge immer den Gegenschlüssel benutzen wie in der Bedienungsanleitung erwaeht.

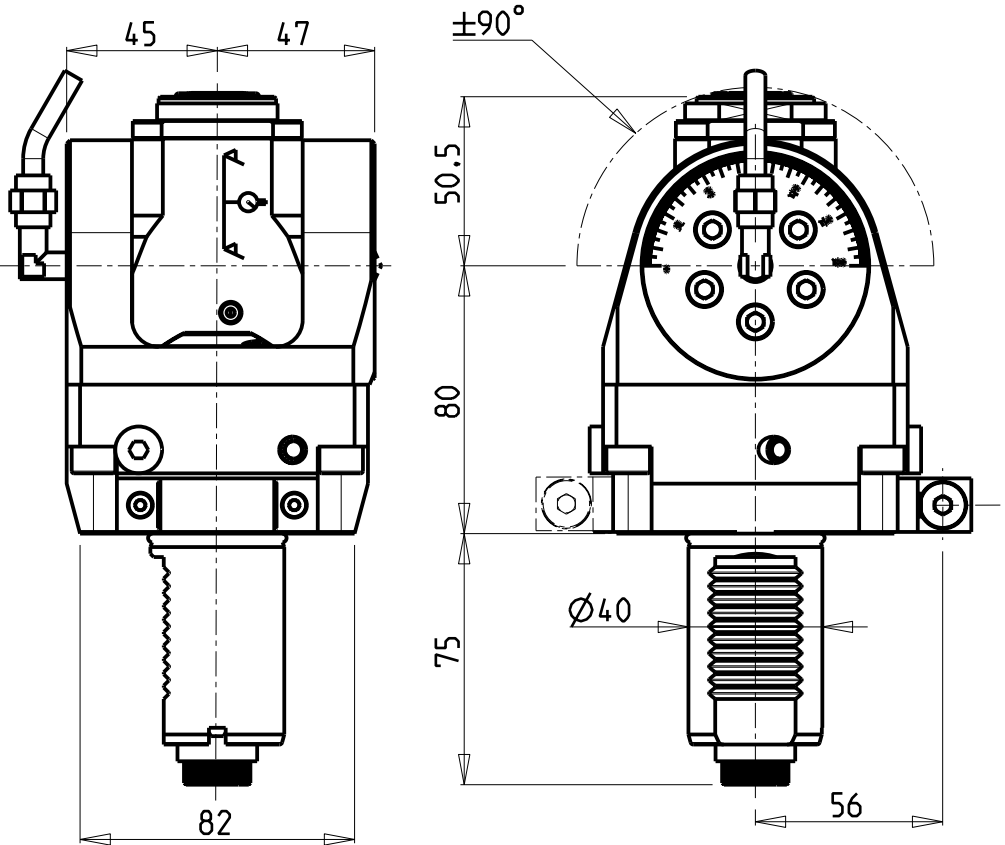

versione dx  
right version  
version rechts

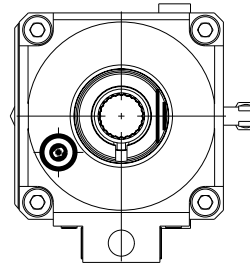

versione sx  
left version  
version links

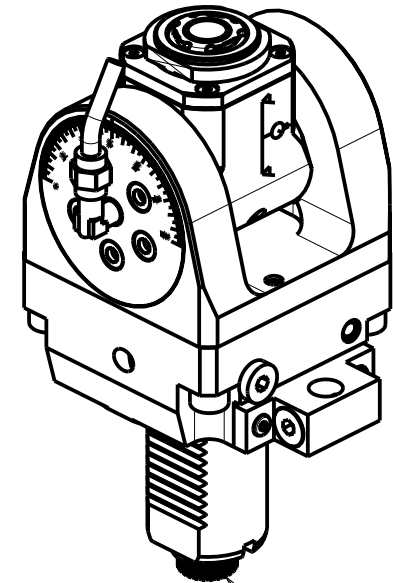
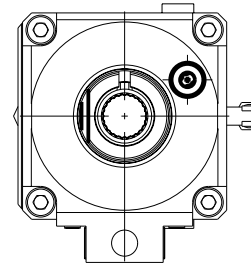

DIN 5480

Cod. MT		Mandrino Spindle Spindel	I	RPM	Coppia Max Max Torque Max Drehmoment	Lubrificazione int. Coolant through Innenkuehlung	Lubrificazione est. Ext. coolant Aussenkuehlung	CHIAVI INCLUSE Keys included Schlüssel inbegriffen		
versione dx right version version rechts	versione sx left version version links							CHUB36	CHUB22	CHTAER20ZC
SAU0750120	SAU0751120	ERA20	1:1	6000	30Nm	-	X	CHUB36	CHUB22	CHTAER20ZC
SAU0750220	SAU0751220	ERA20	1:1	6000	30Nm	P=70bar	X	CHUB36	CHUB22	CHTAER20ZC

SAUTER  
VDI 40

MODULO MOTORIZZATO ORIENTABILE ±90° VDI40 DIN 5480  
±90° adjustable angle driven tool VDI40 DIN 5480  
Angetriebenes Werkzeug schwenkbar ±90° VDI40 DIN 5480

Subject to change without notice.

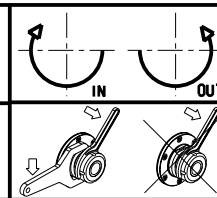

**M.T. srl**

Via Casino Albini 480  
Tel. 0541/956034-957884  
Fax 0541/956341  
47842 S. GIOVANNI IN M. (RN)  
e-mail: mtma@mtmarchetti.com  
http://www.mtmarchetti.com

PRODUZIONE MODULI ROTANTI



PAGINA SAU019-3-70

**ATTENZIONE - ATTENTION - ACHTUNG**

- Per lo smontaggio degli utensili utilizzare sempre la chiave di contrasto come indicato nel manuale d'uso.
- For disassembly of the tools use always the contrast key as mentioned in the user instructions.
- Fuer das Abmontieren der Werkzeuge immer den Gegenschlüssel benutzen wie in der Bedienungsanleitung erwäehnt.

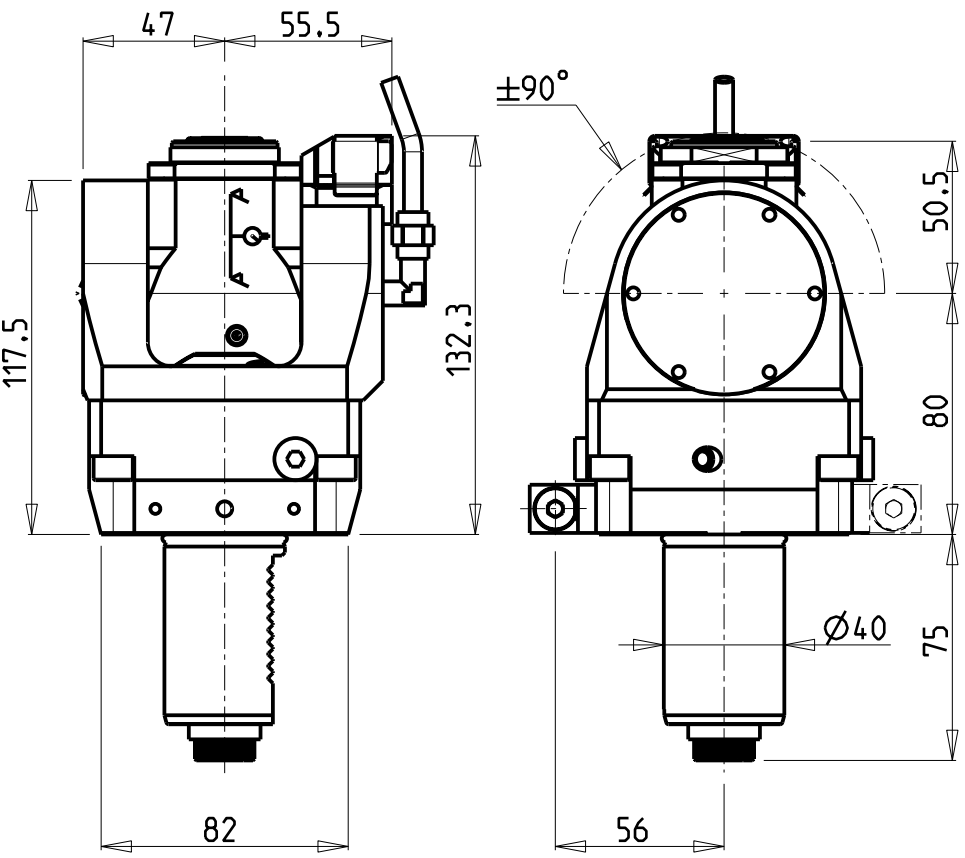

versione dx  
right version  
version rechts

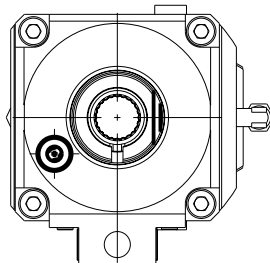

versione sx  
left version  
version links

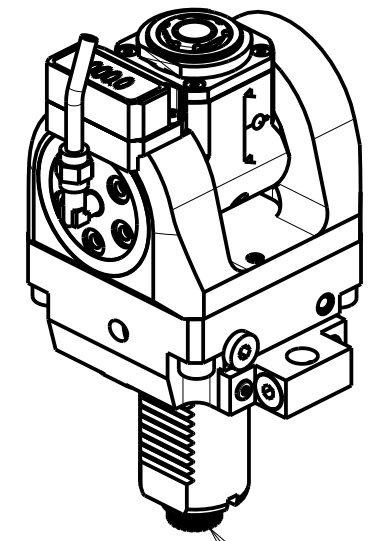
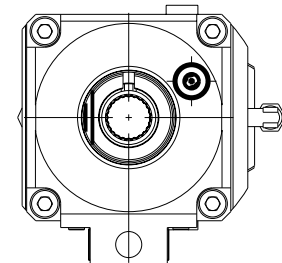

DIN 5480

Cod. MT		Mandrino Spindel Spindel	I	RPM	Coppia Max Max Torque Max Drehmoment	Lubrificazione int. Coolant through Innenkuehlung	Lubrificazione est. Ext. coolant Aussenkuehlung	CHIAVI INCLUSE Keys included Schlüssel inbegriffen		
versione dx right version version rechts	versione sx left version version links							CHUB36	CHUB22	CHTAER20ZC
SAU0755120	SAU0756120	ERA20	1:1	6000	30Nm	-	X	CHUB36	CHUB22	CHTAER20ZC
SAU0755220	SAU0756220	ERA20	1:1	6000	30Nm	P=70bar	X	CHUB36	CHUB22	CHTAER20ZC

SAUTER  
VDI 40

MODULO MOTORIZZATO ORIENTABILE ±90° CON NONIO DIGITALE VDI40 DIN 5480  
±90° adjustable angle driven tool with digital display VDI40 DIN 5480  
Angetriebenes Werkzeug schwenkbar ±90° mit digital display VDI40 DIN 5480

Subject to change without notice.

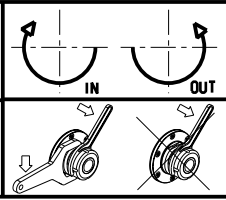

**M.T. srl**  
Via Casino Albini 480  
Tel. 0541/956034-957884  
Fax 0541/956341  
47842 S. GIOVANNI IN M. (RN)  
e-mail: mtma@mtmarchetti.com  
http://www.mtmarchetti.com

PRODUZIONE MODULI ROTANTI



PAGINA SAU019-3-71

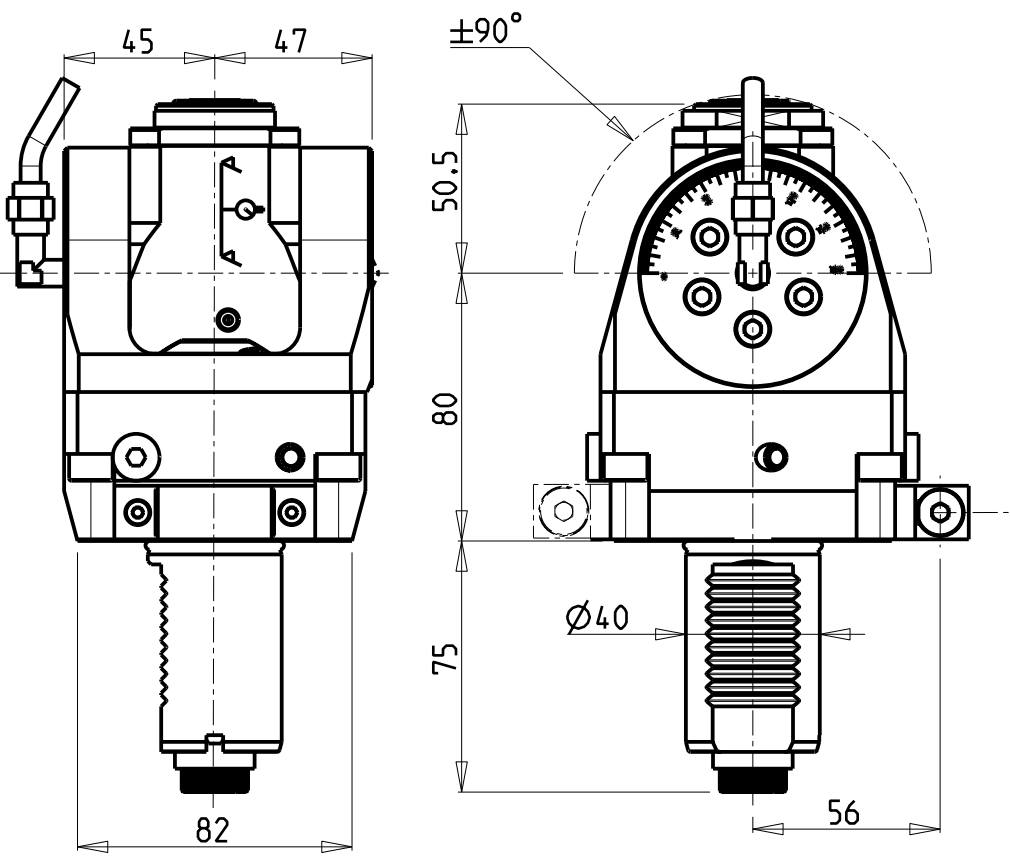

versione dx  
right version  
version rechts

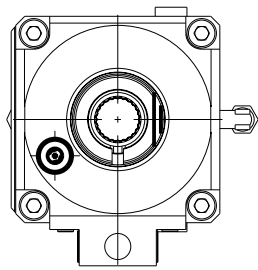

versione sx  
left version  
version links

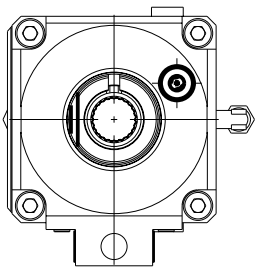

**ATTENZIONE - ATTENTION - ACHTUNG**

- Per lo smontaggio degli utensili utilizzare sempre la chiave di contrasto come indicato nel manuale d'uso.
- For disassembly of the tools use always the contrast key as mentioned in the user instructions.
- Fuer das Abmontieren der Werkzeuge immer den Gegenschlüssel benutzen wie in der Bedienungsanleitung erwäehnt.

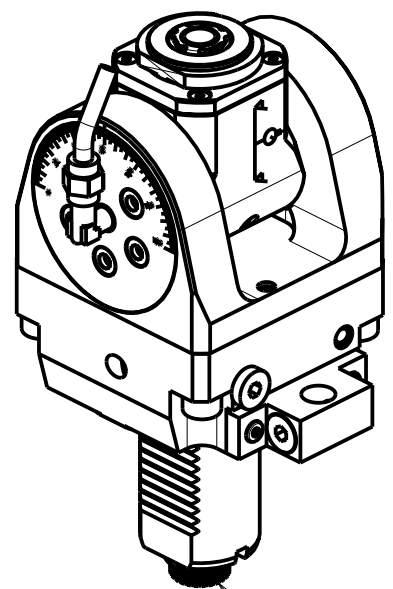

DIN 5480

Cod. MT		Mandrino Spindle Spindel	i	RPM	Coppia Max Max Torque Max Drehmoment	Lubrificazione int. Coolant through Innenkuehlung	Lubrificazione est. Ext. coolant Aussenkuehlung	CHIAVI INCLUSE Keys included Schluessel inbegriffen		
versione dx right version version rechts	versione sx left version version links							CHUB19_SP3	CHUB32	CHTAER16ZC
SAU0750316	SAU0751316	ERA16	1:2	12000	8Nm	-	X	CHUB19_SP3	CHUB32	CHTAER16ZC
SAU0750416	SAU0751416	ERA16	1:2	12000	8Nm	P=70bar	X	CHUB19_SP3	CHUB32	CHTAER16ZC

SAUTER  
VDI 40

MODULO MOTORIZZATO ORIENTABILE ±90° MOLTIPLICATO i=1:2 VDI40 DIN 5480  
±90° adjustable angle driven tool geared-up i=1:2 VDI40 DIN 5480  
Angetriebenes Werkzeug schwenkbar ±90° uebersetzt i=1:2 VDI40 DIN 5480

Subject to change without notice.

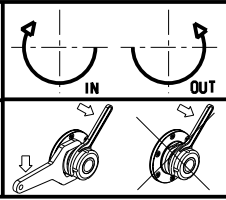

**M.T. srl**

Via Casino Albini 480  
Tel. 0541/956034-957884  
Fax 0541/956341  
47842 S. GIOVANNI IN M. (RN)  
e-mail: mtma@mtmarchetti.com  
http://www.mtmarchetti.com

PRODUZIONE MODULI ROTANTI



PAGINA SAU019-3-80

**ATTENZIONE - ATTENTION - ACHTUNG**

- Per lo smontaggio degli utensili utilizzare sempre la chiave di contrasto come indicato nel manuale d'uso.
- For disassembly of the tools use always the contrast key as mentioned in the user instructions.
- Fuer das Abmontieren der Werkzeuge immer den Gegenschlüssel benutzen wie in der Bedienungsanleitung erwaeht.

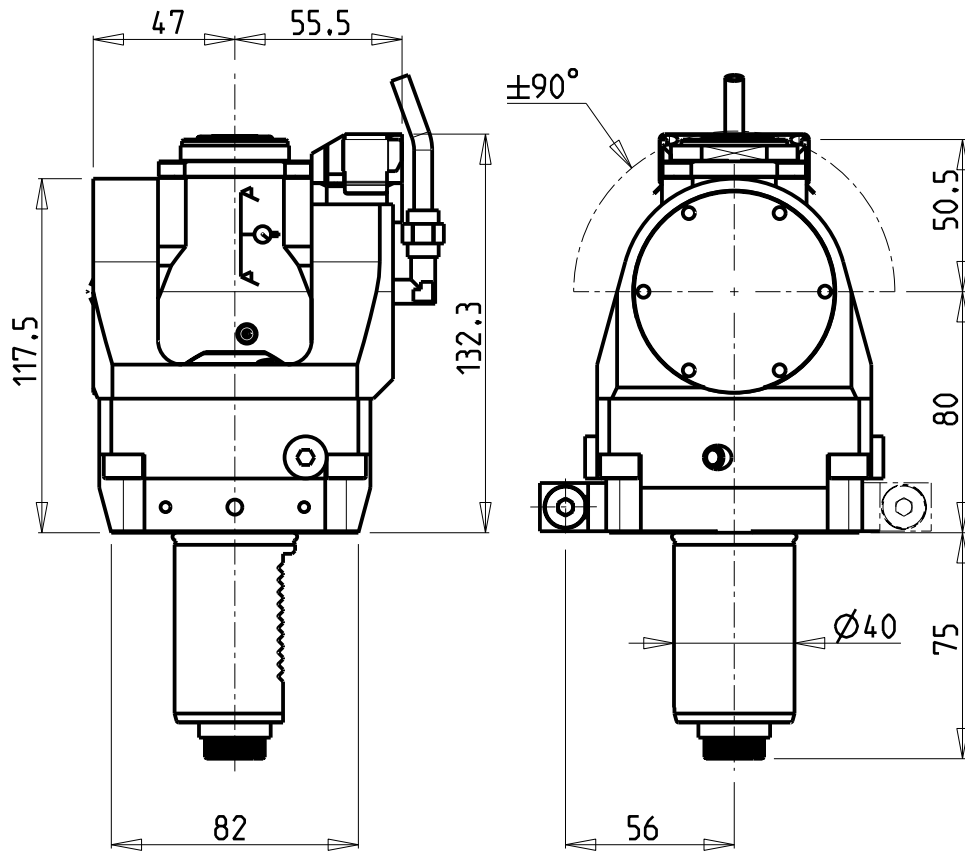

versione dx  
right version  
version rechts

versione sx  
left version  
version links

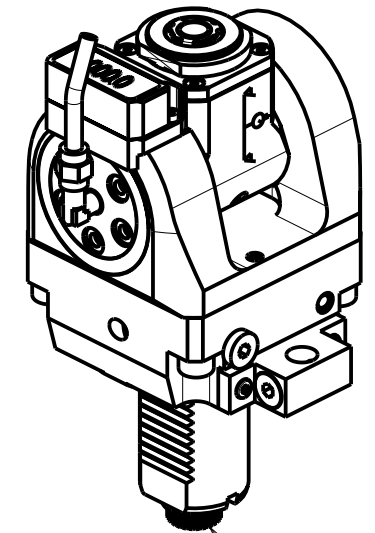
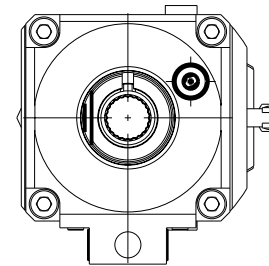
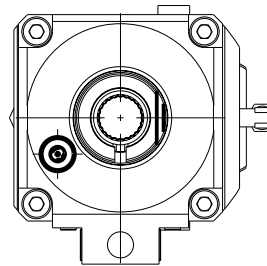

DIN 5480

Cod. MT		Mandrino Spindle Spindel	I	RPM	Coppia Max Max Torque Max Drehmoment	Lubrificazione int. Coolant through Innenkuehlung	Lubrificazione est. Ext. coolant Aussenkuehlung	CHIAVI INCLUSE Keys included Schluesssel inbegriffen		
versione dx right version version rechts	versione sx left version version links									
SAU0755316	SAU0756316	ERA16	1:2	12000	8Nm	-	X	CHUB19_SP3	CHUB32	CHTAER16ZC
SAU0755416	SAU0756416	ERA16	1:2	12000	8Nm	P=70bar	X	CHUB19_SP3	CHUB32	CHTAER16ZC

SAUTER  
VDI 40

MODULO MOTORIZZATO ORIENTABILE  $\pm 90^\circ$  MOLTIPLICATO I=1:2 CON NONIO DIGITALE VDI40 DIN 5480  
 $\pm 90^\circ$  adjustable angle driven tool geared-up I=1:2 with digital display VDI40 DIN 5480  
 Angetriebenes Werkzeug schwenkbar  $\pm 90^\circ$  uebersetzt I=1:2 mit digital display VDI40 DIN 5480

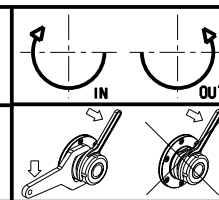

**M.T. srl**

Via Casino Albini 480  
 Tel. 0541/956034-957884  
 Fax 0541/956341  
 47842 S. GIOVANNI IN M. (RN)  
 e-mail: mtma@mtmarchetti.com  
<http://www.mtmarchetti.com>

PRODUZIONE MODULI ROTANTI



PAGINA SAU019-3-81

Subject to change without notice.

10/2018

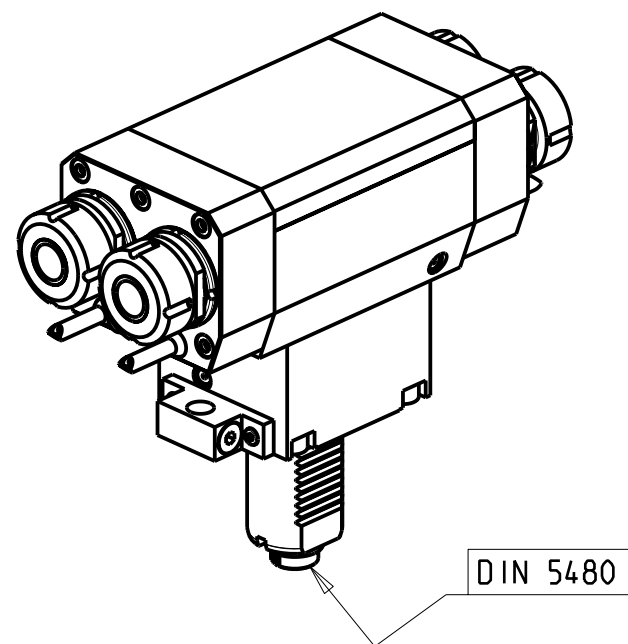
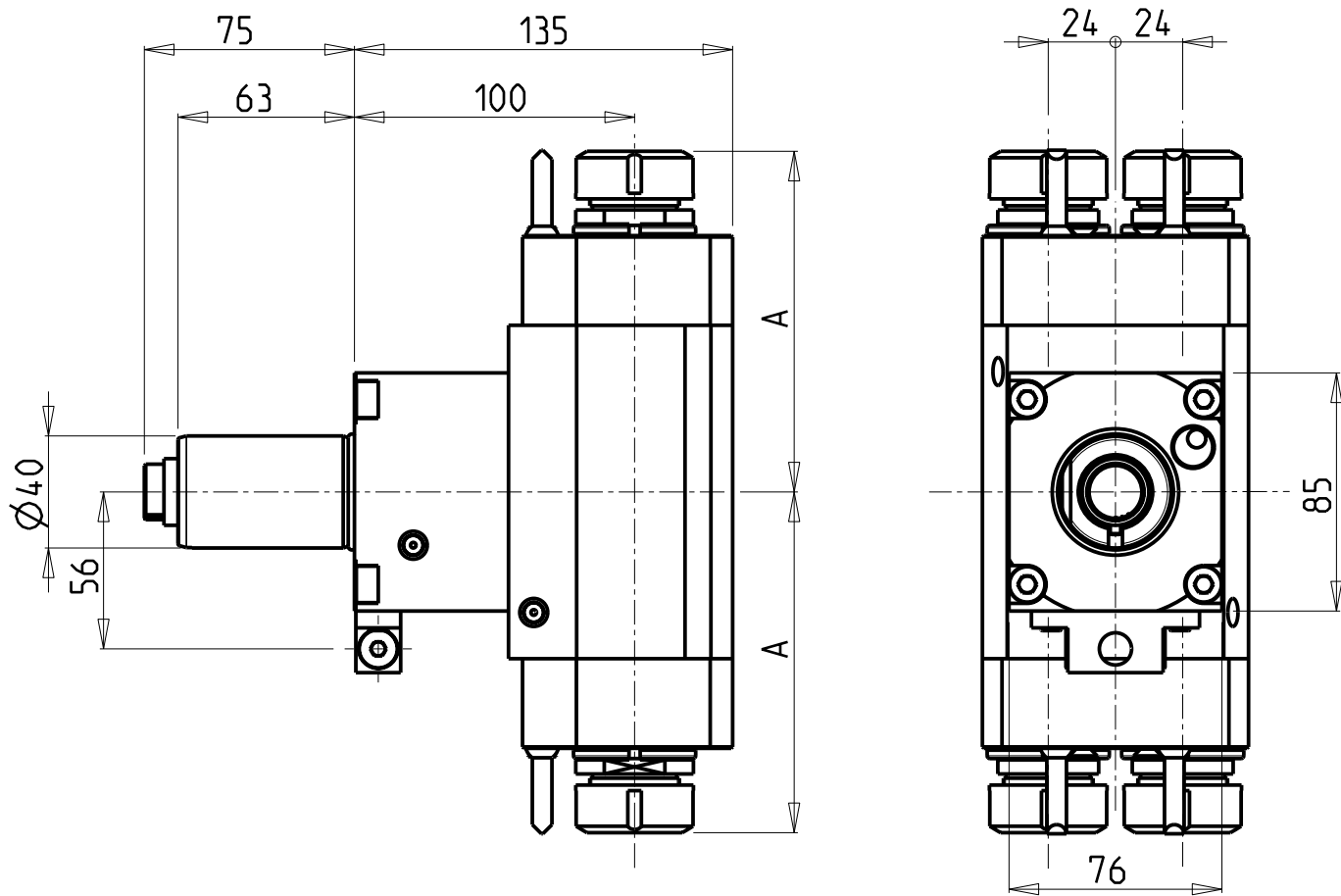

**ATTENZIONE - ATTENTION - ACHTUNG**

- Per lo smontaggio degli utensili utilizzare sempre la chiave di contrasto come indicato nel manuale d'uso.
- For disassembly of the tools use always the contrast key as mentioned in the user instructions.
- Fuer das Abmontieren der Werkzeuge immer den Gegenschlüssel benutzen wie in der Bedienungsanleitung erwäehnt.

Cod. MT	Mandrino Spindle Spindel	I	RPM	Coppia Max Max Torque Max Drehmoment	N°Utensili N°Tools N°Werkzeuge	Lubrificazione est. Ext. coolant Ausseukuehlung	A	CHIAVI NON INCLUSE Keys not included Schluessel nicht einbegriffen	
SAU0510216	ER16+ER16	1:1	6000	50Nm	2+2	X	120.7	CHUB17	CHMNER16
SAU0510225	ER25+ER25	1:1	6000	50Nm	2+2	X	121.6	CHUB36	CHSTER25

**SAUTER**  
**VDI 40**

MODULO MOTORIZZATO RADIALE 2+2 USCITE IN Y VDI40 DIN 5480  
Radial multiple 2+2 outlet driven tool in Y VDI40 DIN 5480  
Radial angetriebenes Mehrspindel-Werkzeug 2+2 Ausgaenge in Y VDI40 DIN 5480

Subject to change without notice.

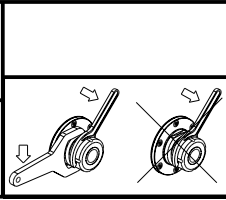

**M.T. srl**  
Via Casino Albini 480  
Tel. 0541/956034-957884  
Fax 0541/956341  
47842 S. GIOVANNI IN M. (RN)  
e-mail: mtma@mtmarchetti.com  
http://www.mtmarchetti.com

PRODUZIONE MODULI ROTANTI



PAGINA SAU020-3-00



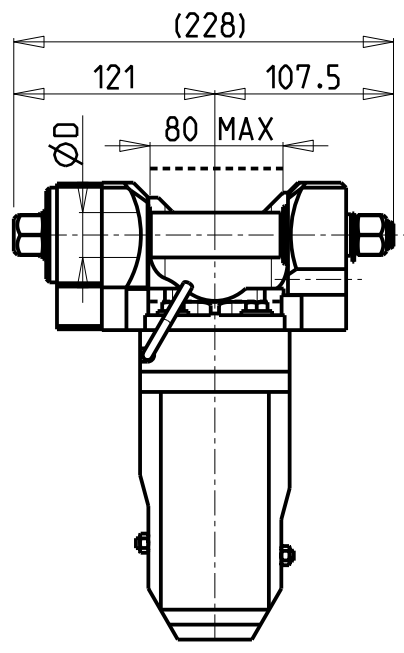
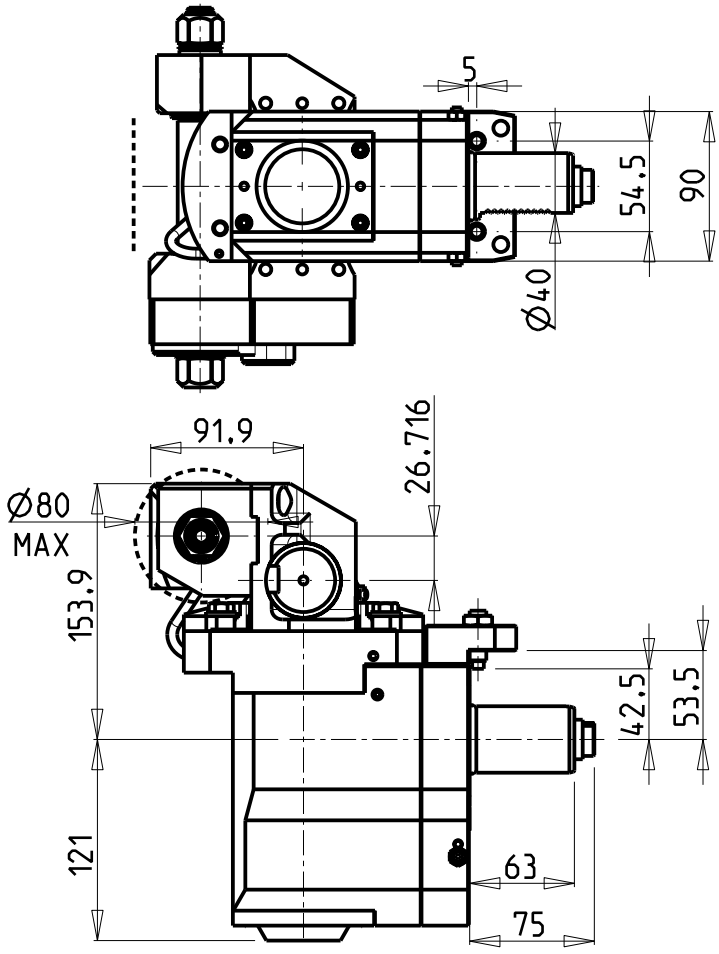

versione dx  
right version  
version rechts

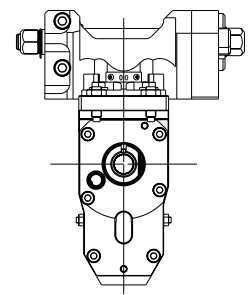

versione universale  
universal version  
universal version

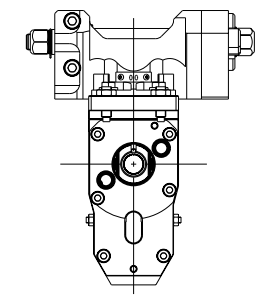

**TORRETTE ASSIALI  
AXIAL TURRETS  
AXIAL REVOLVER**

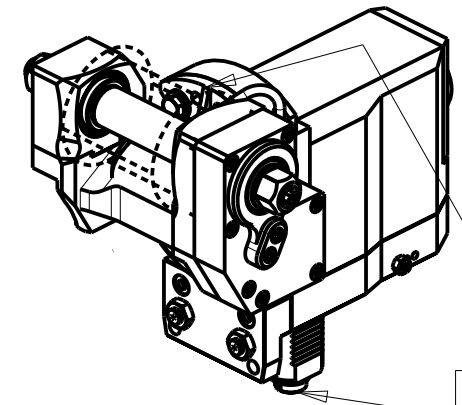
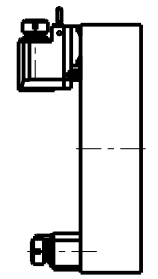

INCLINAZIONE  
REGOLABILE ±20°

DIN 5480

PER ALBERI E DISTANZIALI VEDI PAG. TBL250-1-00  
FOR SHAFT END SPACER SEE PAGE TBL250-1-00  
FUER DORN UND ABSTANDSSTUECK SEITE TBL250-1-00

Cod. MT		I	RPM	Coppia Max Max Torque Max Drehmoment	Lubrificazione est. Ext. coolant Aussenkuehlung	D (mm)	D (Inch)	CHIAVI INCLUSE Keys included Schluessel einbegriffen			DOTAZIONI - SUPPLIED WITH - AUSSTATTUNG	
versione dx right version version rechts	versione universale universal version universal version							mm / inch	- N°1 ALBERO + DISTANZIALI - N°1 SHAFT + SPACER - N°1 DORN + ABSTANDSSTUECK			
SAU0011140	SAU0015140	1:1	6000	60Nm	X	16-22-27-32	3/4"-1"-1 1/4"	CHUB24	CHUB13	CHESL08		
SAU0012140	SAU0016140	2:1	3000	80Nm	X	16-22-27-32	3/4"-1"-1 1/4"	CHUB24	CHUB13	CHESL08		

**SAUTER**  
VDI 40  
MODULO MOTORIZZATO PORTACREATORE VDI40 DIN 5480  
Driven gear hobber VDI40 DIN 5480  
Angetriebenes Zahnradwaeltzraes-Werkzeug VDI40 DIN 5480

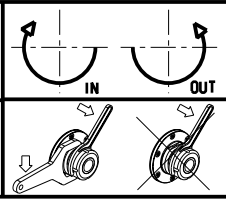

**M.T. srl**  
Via Casino Albini 480  
Tel. 0541/956034-957884  
Fax 0541/956341  
47842 S. GIOVANNI IN M. (RN)  
e-mail: mtma@mtmarchetti.com  
http://www.mtmarchetti.com

PRODUZIONE MODULI ROTANTI  
  
PAGINA SAU340-3-00

Subject to change without notice.

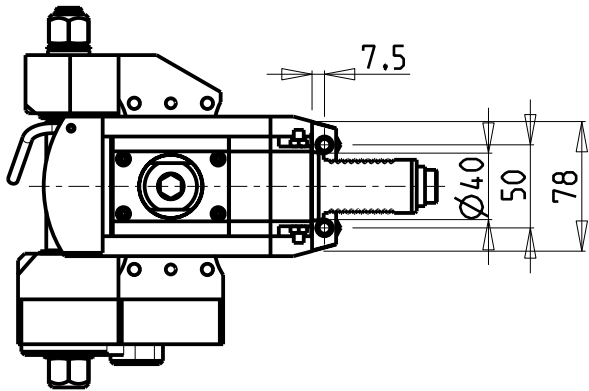

versione universale  
universal version  
universal version

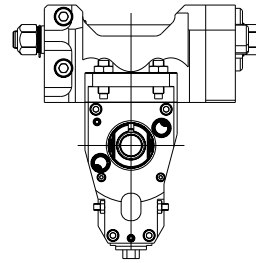

**TORRETTE ASSIALI**  
**AXIAL TURRETS**  
**AXIAL REVOLVER**

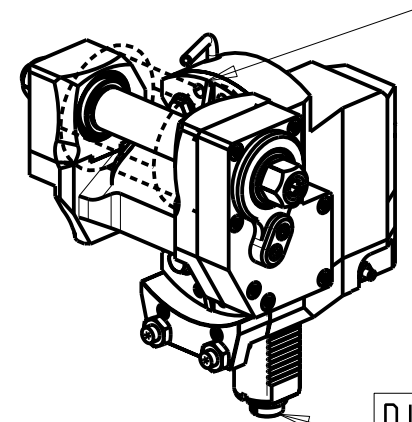
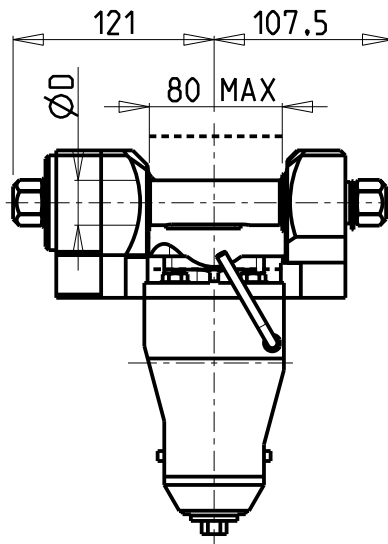
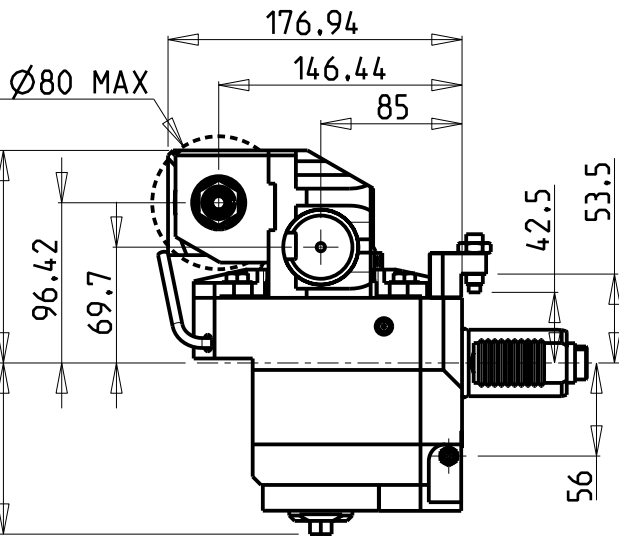
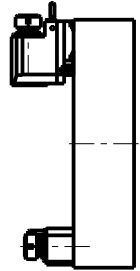

INCLINAZIONE  
REGOLABILE  $\pm 20^\circ$

DIN 5480

PER ALBERI E DISTANZIALI VEDI PAG. TBL250-1-00  
FOR SHAFT END SPACER SEE PAGE TBL250-1-00  
FUER DORN UND ABSTANDSSTUECK SEITE TBL250-1-00

**DOTAZIONI - SUPPLIED WITH - AUSSTATTUNG**

mm / inch	
	- N°1 ALBERO + DISTANZIALI
	- N°1 SHAFT + SPACER
	- N°1 DORN + ABSTANDSSTUECK

Cod. MT	I	RPM	Coppia Max Max Torque Max Drehmoment	Lubrificazione est. Ext. coolant Aussenkuehlung	D (mm)	D (Inch)	CHIAVI INCLUSE Keys included Schlüssel einbegriffen		
							CHUB24	CHUB13	CHESL08
SAU0871120	1:1	6000	60Nm	X	16-22-27-32	3/4"-1"-1 1/4"	CHUB24	CHUB13	CHESL08
SAU0872120	2:1	3000	80Nm	X	16-22-27-32	3/4"-1"-1 1/4"	CHUB24	CHUB13	CHESL08

**SAUTER**  
**VDI 40**  
MODULO MOTORIZZATO PORTACREATORE VDI40 DIN 5480  
Driven gear hobber VDI40 DIN 5480  
Angetriebenes Zahnradwaelzfraes-Werkzeug VDI40 DIN 5480

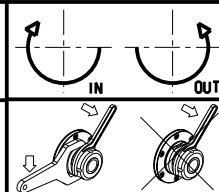

**M.T. srl**  
Via Casino Albini 480  
Tel. 0541/956034-957884  
Fax 0541/956341  
47842 S. GIOVANNI IN M. (RN)  
e-mail: mtma@mtmarchetti.com  
http://www.mtmarchetti.com

PRODUZIONE MODULI ROTANTI  
**MT**  
PAGINA SAU340-3-01

Subject to change without notice.

10/2018

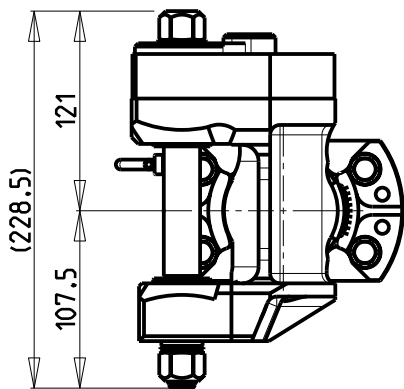
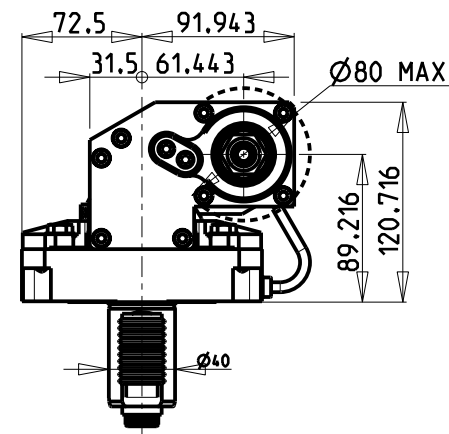
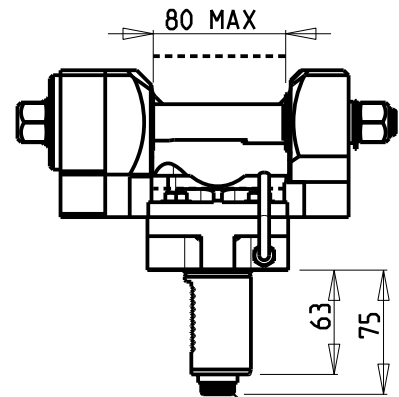
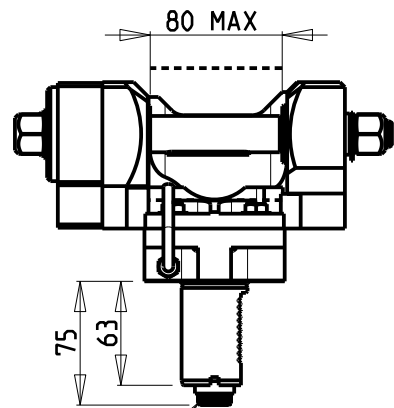
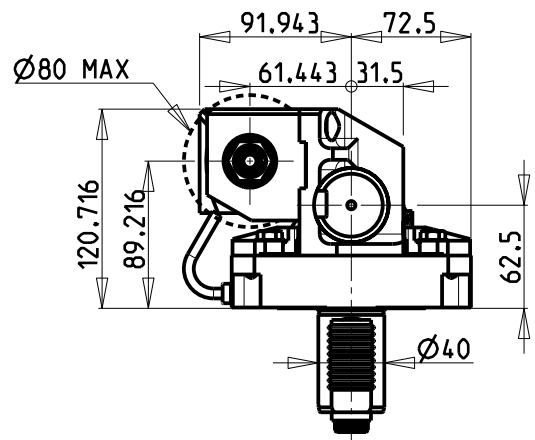

INCLINAZIONE  
REGOLABILE ±20°

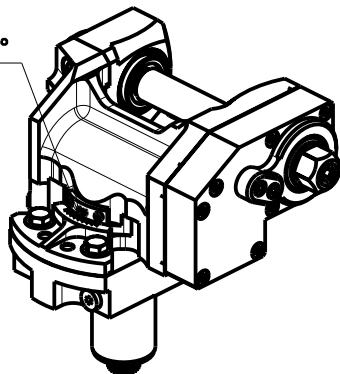

DIN 5480

DIN 5480

PER ALBERI E DISTANZIALI VEDI PAG. TBL250-1-00  
FOR SHAFT END SPACER SEE PAGE TBL250-1-00  
FUER DORN UND ABSTANDSSTUECK SEITE TBL250-1-00

**DOTAZIONI - SUPPLIED WITH - AUSSTATTUNG**

mm / inch	- N°1 ALBERO + DISTANZIALI
	- N°1 SHAFT + SPACER
	- N°1 DORN + ABSTANDSSTUECK

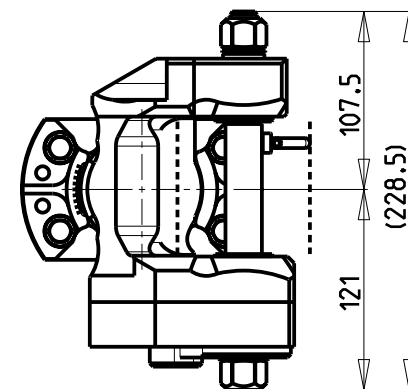

TORRETTE RADIALI  
RADIAL TURRETS  
RADIAL REVOLVER

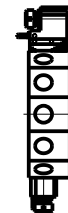

Cod. MT		I	RPM	Coppia Max Max Torque Max Drehmoment	Lubrificazione est. Ext. coolant Auslenkuehlung	D (mm)	D (Inch)	CHIAVI INCLUSE Keys included Schlüssel einbegriffen		
versione dx right version version rechts	versione sx left version version links							C HUB24	C HUB13	C HESL08
SAU0051100	SAU0051110	1:1	6000	60Nm	X	16-22-27-32	3/4"-1"-1 1/4"	C HUB24	C HUB13	C HESL08
SAU0052100	SAU0052110	2:1	3000	80Nm	X	16-22-27-32	3/4"-1"-1 1/4"	C HUB24	C HUB13	C HESL08

SAUTER  
VDI 40

MODULO MOTORIZZATO PORTACREATORE VDI40 DIN 5480

Driven gear hobber VDI40 DIN 5480

Angetriebenes Zahnradwaelzfraes-Werkzeug VDI40 DIN 5480

Subject to change without notice.

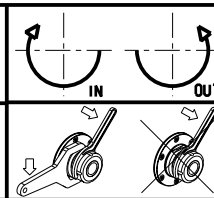

**M.T. srl**

Via Casino Albini 480  
Tel. 0541/956034-957884  
Fax 0541/956341

47842 S. GIOVANNI IN M. (RN)  
e-mail: mtma@mtmarchetti.com  
http://www.mtmarchetti.com

PRODUZIONE MODULI ROTANTI



PAGINA SAU340-3-05

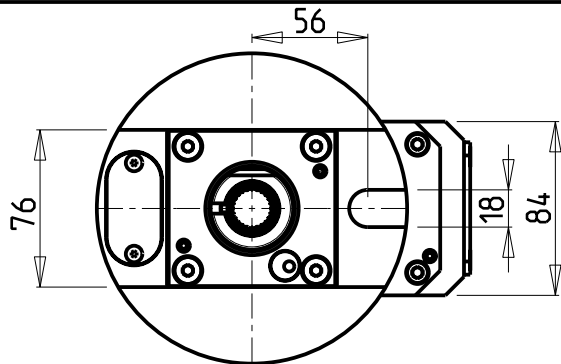

versione dx  
right version  
version rechts

versione sx  
left version  
version links

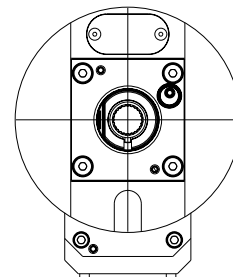
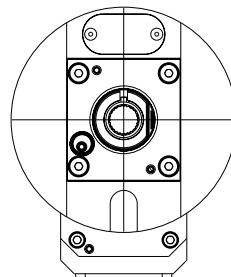

**ATTENZIONE - ATTENTION - ACHTUNG**

- VERIFICARE LE MISURE DI INGOMBRO PER POSSIBILE INTERFERENZA SU ALCUNI MODELLI DI MACCHINE
- Please check the overall sizes for possible interferences on some machine models
- Bitte überprüfen sie das ausmass um mögliche interferenzen auf einigen maschinen modellen zu vermeiden

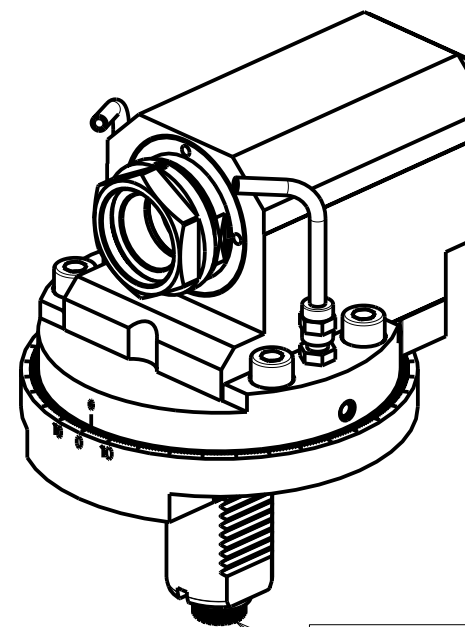
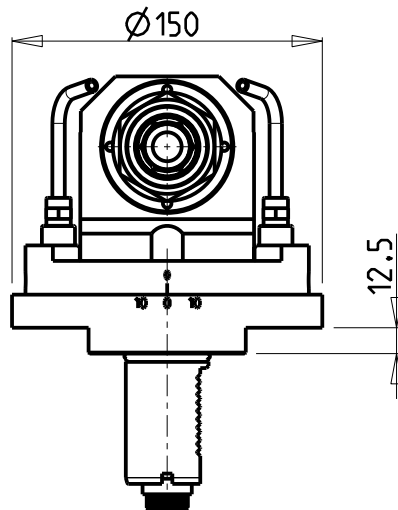
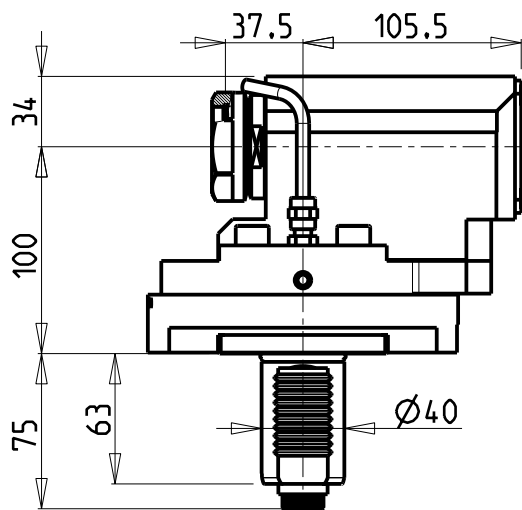

DIN 5480

PER PORTAUTENSILI MODULARI MTSK-40 VEDI PAG. TBL300-1-40  
FOR MTSK-40 QUIK CHANGE TOOLHOLDERS CLAMPINGS SEE PAGE TBL300-1-40  
FUER MTSK-40 MODULARE WERKZEUGAUFNAHMEN SIEHE SEITE TBL300-1-40

Cod. MT		Mandrino Spindle Spindel	I	RPM	Coppia Max Max Torque Max Drehmoment	Lubrificazione est. Ext. coolant Aussehenkuehlung	CHIAVI INCLUSE Keys included Schluessel einbegriffen
versione dx right version version rechts	versione sx left version version links						
SAU0760100	SAU0761100	MTSK-40	1:1	6000	50Nm	X	n°2 CHUB46

SAUTER  
VDI 40

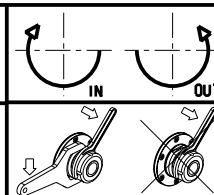

**M.T. srl**  
Via Casino Albini 480  
Tel. 0541/956034-957884  
Fax 0541/956341  
47842 S. GIOVANNI IN M. (RN)  
e-mail: mtma@mtmarchetti.com  
http://www.mtmarchetti.com

PRODUZIONE MODULI ROTANTI



MODULO MOTORIZZATO ASSIALE MTSK PER POWER SKIVING H=100mm VDI40 DIN 5480  
Axial MTSK driven tool for Power Skiving H=100mm VDI40 DIN 5480  
Axial MTSK angetriebenes Werkzeug fuer Power Skiving H=100mm VDI40 DIN 5480

PAGINA SAU350-3-00-K

Subject to change without notice.

10/2018

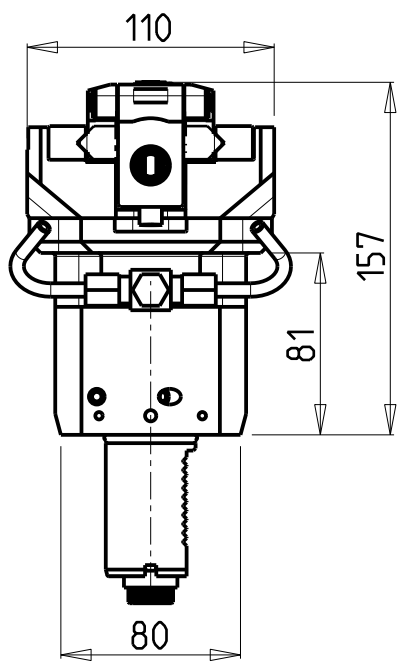
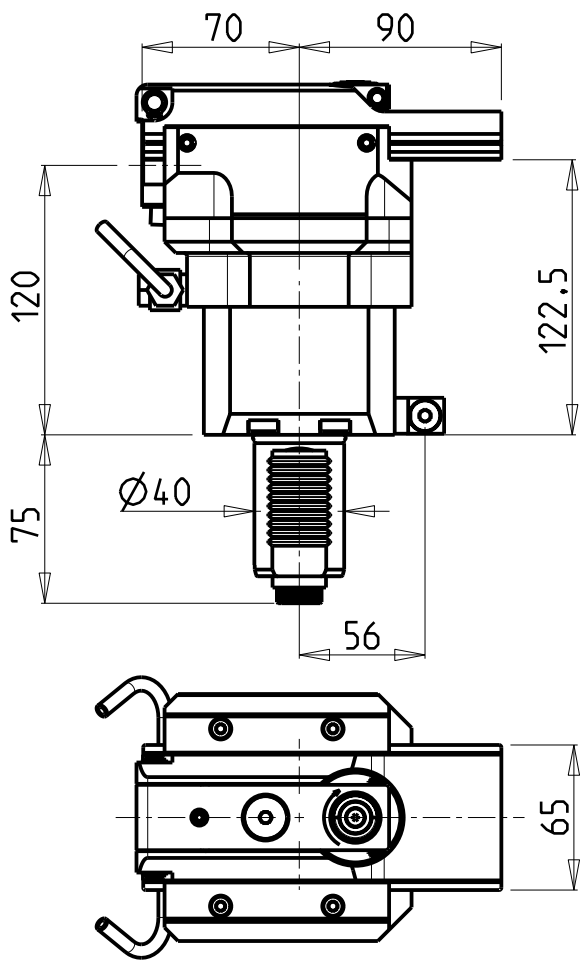

versione dx  
right version  
version rechts

versione sx  
left version  
version links

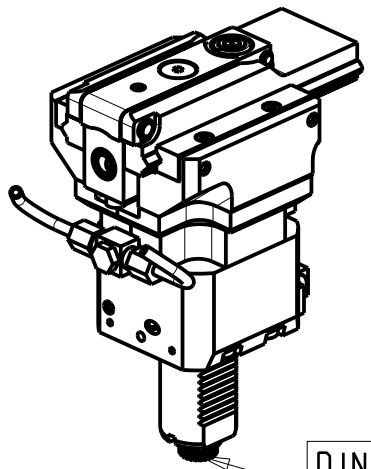
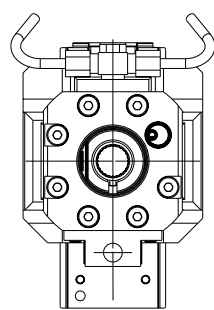
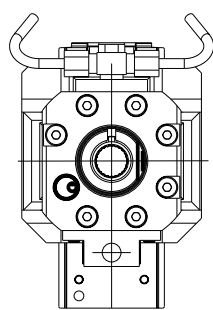

DIN 5480

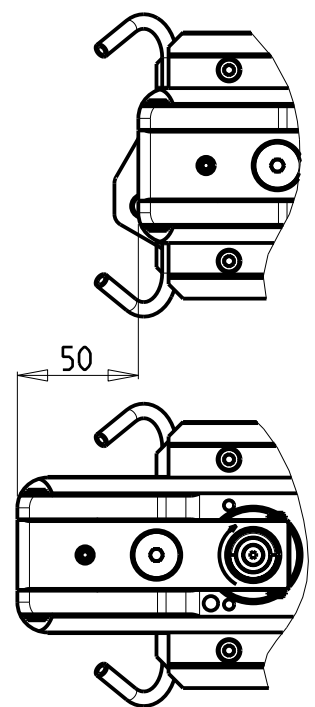

Cod. MT		i	RPM MAX	Lubr. esterna Ext. coolant Aussenkuehlung
versione dx right version version rechts	versione sx left version version links			
SAU0720100	SAU0721100	4:1	2000	X

PER UTENSILI STOZZATORI VEDI PAG. TBL400-1-00  
FOR DRIVEN SLOTTING TOOL CUTTING-TOOLS SEE PAGE TBL400-1-00  
FÜR NUTENSTOSS-WERKZEUG SCHNEIDWERKZEUGE SIEHE SEITE TBL400-1-00

SAUTER  
VDI 40  
MODULO MOTORIZZATO STOZZATORE CORSA 50mm H=120mm VDI40 DIN 5480  
Slotting driven tool 50mm stroke H=120mm VDI40 DIN 5480  
Keilnutenstossmaschine 50mm Hub H=120mm VDI40 DIN 5480

**M.T. srl**  
Via Casino Albini 480  
Tel. 0541/956034-957884  
Fax 0541/956341  
47842 S. GIOVANNI IN M. (RN)  
e-mail: mtma@mtmarchetti.com  
http://www.mtmarchetti.com

PRODUZIONE MODULI ROTANTI  
  
 PAGINA SAU360-3-00

Subject to change without notice.

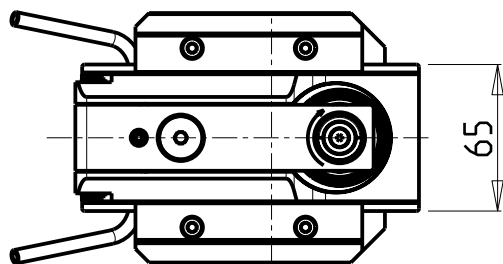
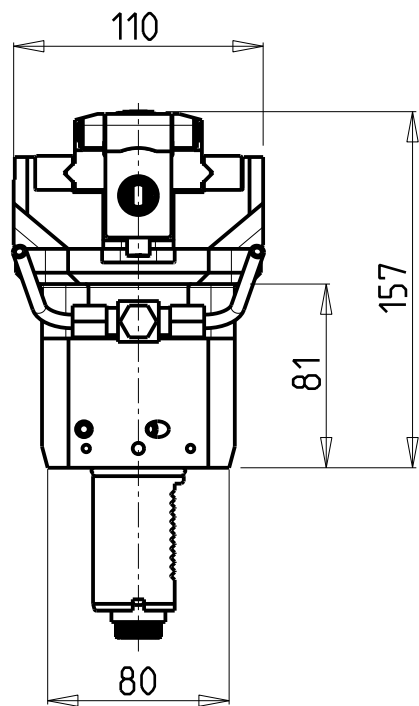
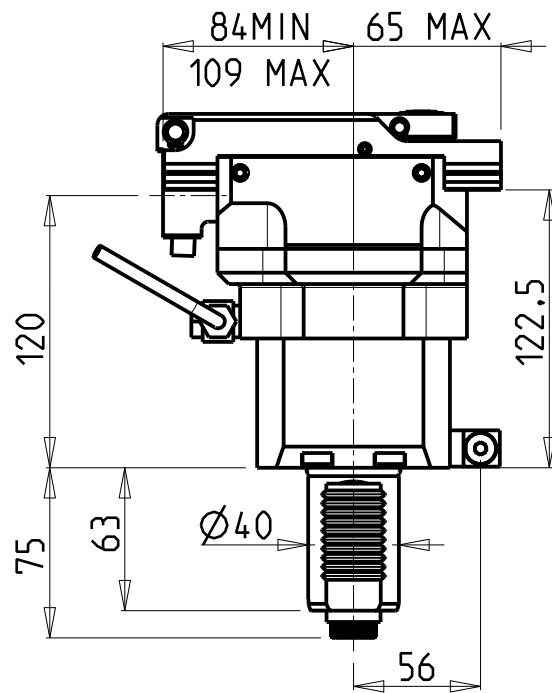

versione dx  
right version  
version rechts

versione sx  
left version  
version links

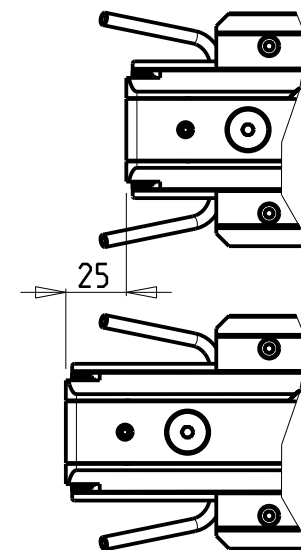
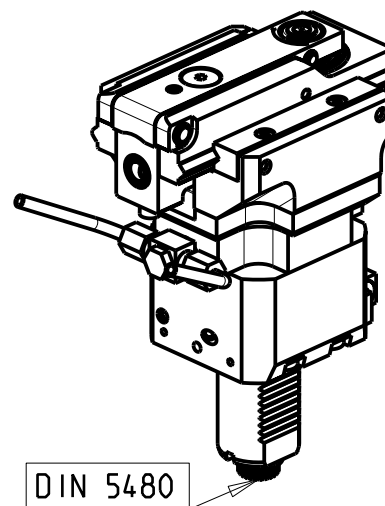
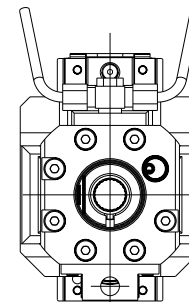
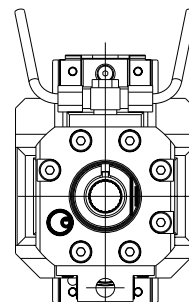

PER UTENSILI STOZZATORI VEDI PAG. TBL400-1-00  
FOR DRIVEN SLOTTING TOOL CUTTING-TOOLS SEE PAGE TBL400-1-00  
FÜR NUTENSTOSS-WERKZEUG SCHNEIDWERKZEUGE SIEHE SEITE TBL400-1-00

Cod. MT		I	RPM MAX	Lubr. esterna Ext. coolant Aussenkuehlung
versione dx right version version rechts	versione sx left version version links			
SAU0720200	SAU0721200	4:1	2400	X

SAUTER  
VDI 40

MODULO MOTORIZZATO STOZZATORE CORSA 25mm H=120mm VDI40 DIN 5480  
Slotting driven tool 25mm stroke H=120mm VDI40 DIN 5480  
Keilnutenstossmaschine 25mm Hub H=120mm VDI40 DIN 5480

**M.T. srl**

Via Casino Albini 480  
Tel. 0541/956034-957884  
Fax 0541/956341  
47842 S. GIOVANNI IN M. (RN)  
e-mail: mtma@mtmarchetti.com  
http://www.mtmarchetti.com

PRODUZIONE MODULI ROTANTI



PAGINA SAU360-3-01

Subject to change without notice.

10/2018

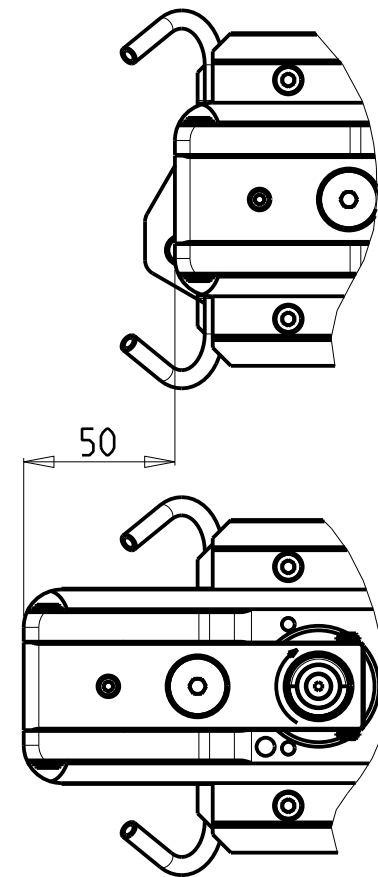
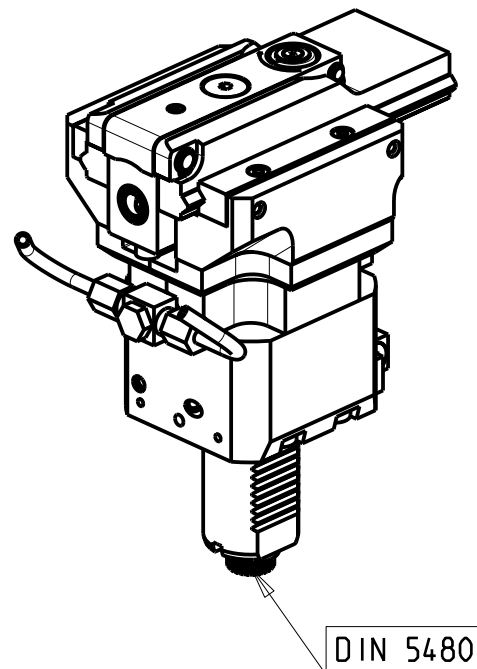
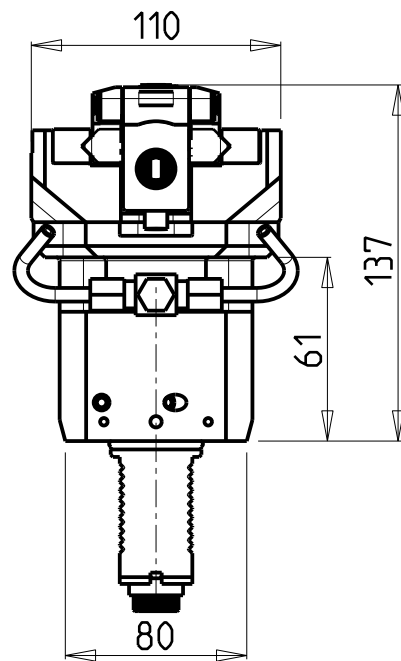
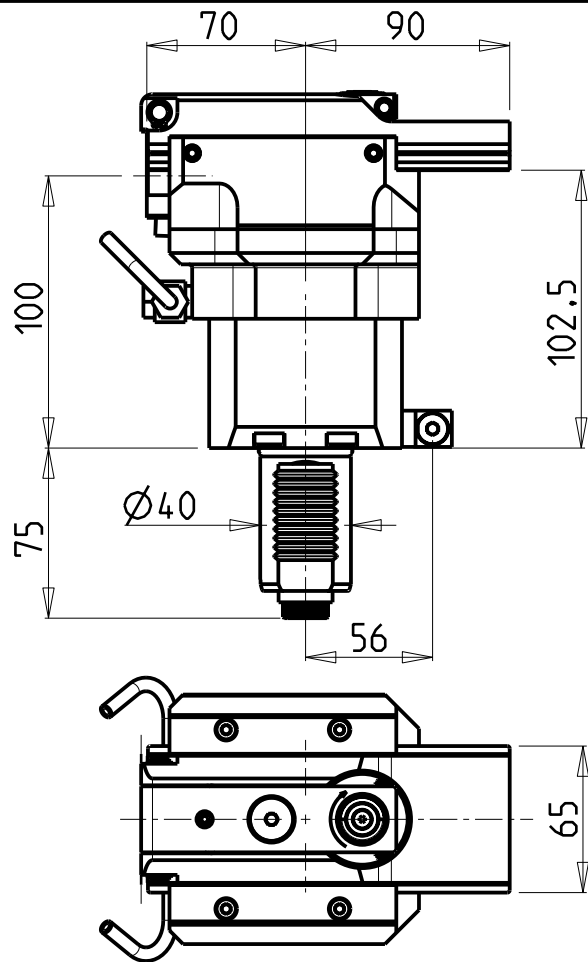

PER UTENSILI STOZZATORI VEDI PAG. TBL400-1-00  
 FOR DRIVEN SLOTTING TOOL CUTTING-TOOLS SEE PAGE TBL400-1-00  
 FÜR NUTENSTOSS-WERKZEUG SCHNEIDEWERKZEUGE SIEHE SEITE TBL400-1-00

Cod. MT		RPM MAX	Lubrificazione est. Ext. coolant Auslenkuehlung
versione universale universal version universal version	I		
SAU0782100	4:1	2000	X

SAUTER  
VDI 40

MODULO MOTORIZZATO STOZZATORE CORSA 50mm H=100mm VDI40 DIN 5480  
 Slotting driven tool 50mm stroke H=100mm VDI40 DIN 5480  
 Keilnutenstossmaschine 50mm Hub H=100mm VDI40 DIN 5480

**M.T. srl**

Via Casino Albini 480  
 Tel. 0541/956034-957884  
 Fax 0541/956341  
 47842 S. GIOVANNI IN M. (RN)  
 e-mail: mtma@mtmarchetti.com  
 http://www.mtmarchetti.com

PRODUZIONE MODULI ROTANTI



PAGINA SAU360-3-10

Subject to change without notice.

10/2018

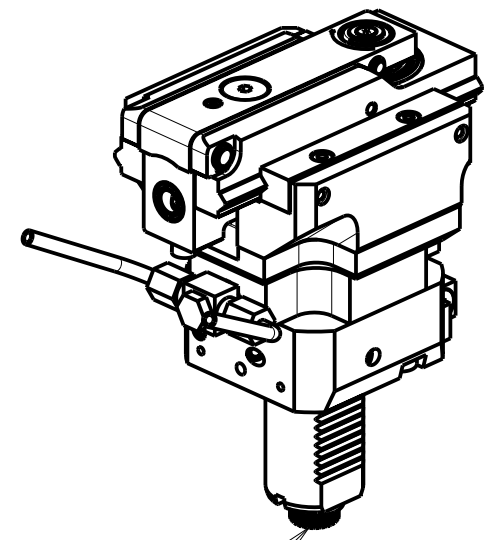
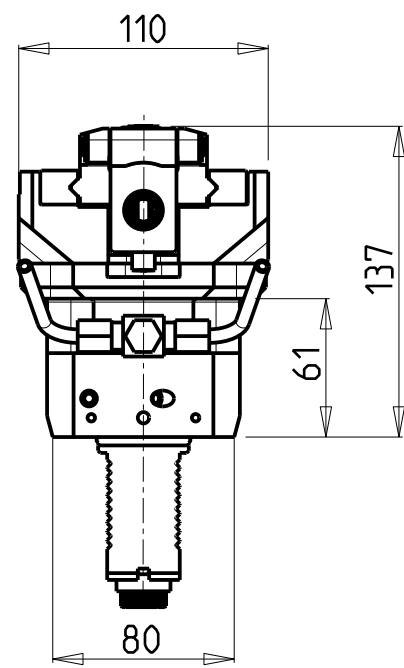
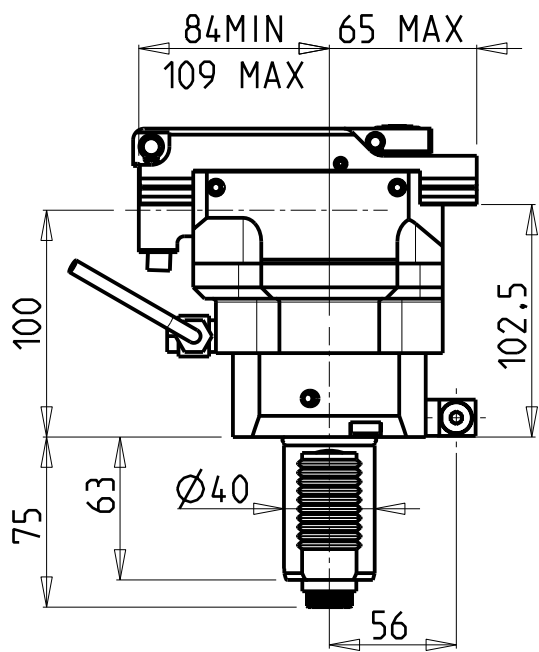

DIN 5480

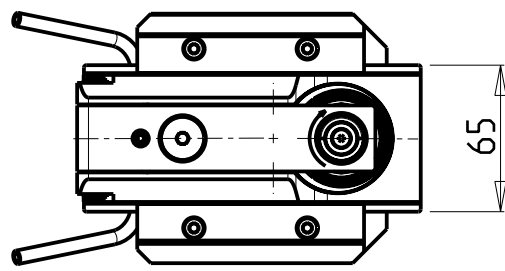
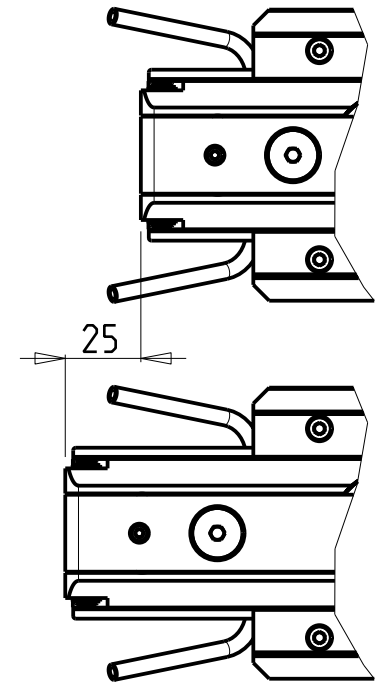

PER UTENSILI STOZZATORI VEDI PAG. TBL400-1-00  
 FOR DRIVEN SLOTTING TOOL CUTTING-TOOLS SEE PAGE TBL400-1-00  
 FÜR NUTENSTOSS-WERKZEUG SCHNEIDWERKZEUGE SIEHE SEITE TBL400-1-00

Cod. MT	I	RPM MAX	Lubrificazione est. Ext. coolant Aussenkuehlung
SAU0782200	4:1	2400	X

SAUTER  
 VDI 40

MODULO MOTORIZZATO STOZZATORE CORSA 25mm H=100mm VDI40 DIN 5480  
 Slotting driven tool 25mm stroke H=100mm VDI40 DIN 5480  
 Keilnutenstossmaschine 25mm Hub H=100mm VDI40 DIN 5480

Subject to change without notice.

**M.T. srl**  
 Via Casino Albini 480  
 Tel. 0541/956034-957884  
 Fax 0541/956341  
 47842 S. GIOVANNI IN M. (RN)  
 e-mail: mtma@mtmarchetti.com  
 http://www.mtmarchetti.com

PRODUZIONE MODULI ROTANTI



PAGINA SAU360-3-11