

**TORRETTE ASSIALI  
AXIAL TURRETS  
AXIAL REVOLVER**

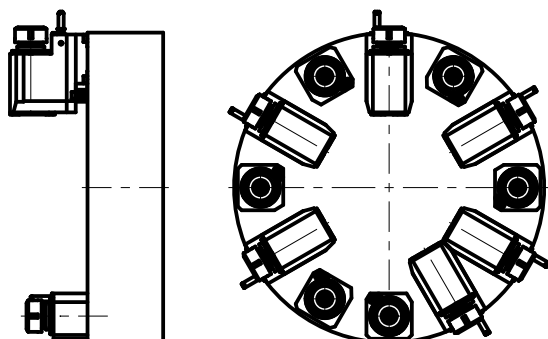

**TORRETTE RADIALI  
RADIAL TURRETS  
RADIAL REVOLVER**

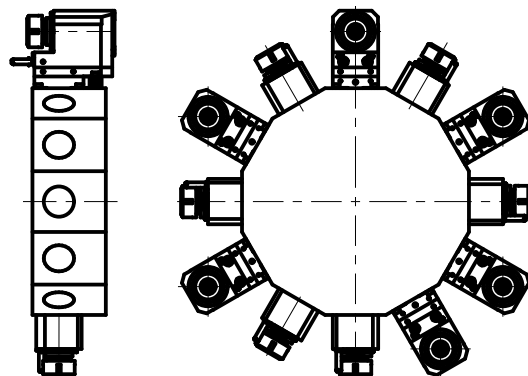

<b>MACCHINE MACHINES MASCHINEN</b>	<b>MODELLI MODELS MODELLE</b>
<b>ANGELINI</b>	Snupy
<b>BOEHRINGER</b>	16 M
<b>CAZENEUVE</b>	CT 200
<b>COLCHESTER</b>	120 M - T 6 M
<b>DMT</b>	KDS 301
<b>EMCO</b>	EMCO Turn 345/360/400
<b>GILDEMEISTER</b>	CTX 310 alt - CTX 310 ECO - CTX 400
<b>GRAZIANO</b>	GR 300/350
<b>MAGDEBURGER</b>	M 110/130/300
<b>MAX MULLER</b>	MD 3 iT
<b>MONFORTS</b>	RNC 2/3/200
<b>NILES</b>	N 10
<b>SOMAB</b>	Transmab 400
<b>SPINNER</b>	TC 65 MC
<b>STOREBRO</b>	STB 2000 - STM 2000
<b>TRAUB</b>	TNA 300
<b>WEILER</b>	DZ 45/67
<b>WFL</b>	WNC 300

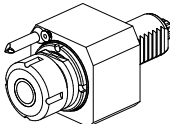
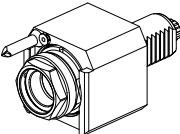
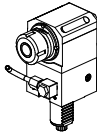
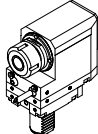
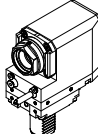
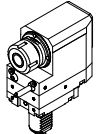
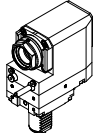
		PAGINA Page Seite
<p><b>MODULO MOTORIZZATO ASSIALE VDI30 DIN 5482</b> Axial driven tool VDI30 DIN 5482 Axial angetriebenes Werkzeug VDI30 DIN 5482</p>		SAU014.2.00
<p><b>MODULO MOTORIZZATO ASSIALE MTSK VDI30 DIN 5482</b> Axial MTSK driven tool VDI30 DIN 5482 Axial MTSK angetriebenes Werkzeug VDI30 DIN 5482</p>		SAU014.2.00.K
<p><b>MODULO MOTORIZZATO RADIALE VDI30 DIN 5482</b> Radial driven tool VDI30 DIN 5482 Radial angetriebenes Werkzeug VDI30 DIN 5482</p>		SAU015.2.00
<p><b>MODULO MOTORIZZATO RADIALE ARRETRATO VDI30 DIN 5482 H=75mm</b> Radial rear-set driven tool VDI30 DIN 5482 H=75mm Radial angetriebenes Werkzeug zurueckversetzt VDI30 DIN 5482 H=75mm</p>		SAU015.2.60
<p><b>MODULO MOTORIZZ. RADIALE ARRETRATO MTSK VDI30 DIN 5482 H=75mm</b> Radial MTSK rear-set driven tool VDI30 DIN 5482 H=75mm Radial MTSK angetriebenes Werkzeug zurueckversetzt VDI30 DIN 5482 H=75mm</p>		SAU015.2.60.K
<p><b>MODULO MOTORIZZATO RADIALE ARRETRATO VDI30 DIN 5482 H=85mm</b> Radial rear-set driven tool VDI30 DIN 5482 H=85mm Radial angetriebenes Werkzeug zurueckversetzt VDI30 DIN 5482 H=85mm</p>		SAU015.2.70
<p><b>MODULO MOTORIZZ. RADIALE ARRETRATO MTSK VDI30 DIN 5482 H=85mm</b> Radial MTSK rear-set driven tool VDI30 DIN 5482 H=85mm Radial MTSK angetriebenes Werkzeug zurueckversetzt VDI30 DIN 5482 H=85mm</p>		SAU015.2.70.K

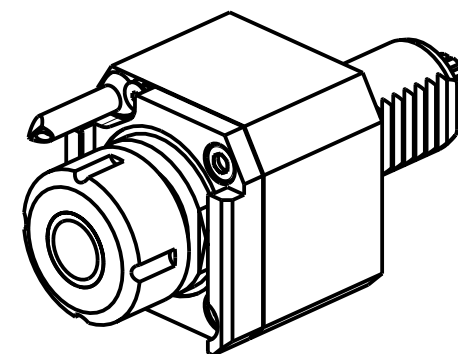
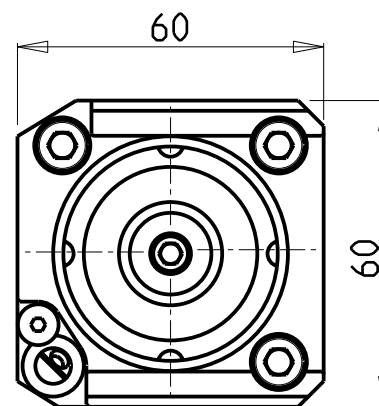
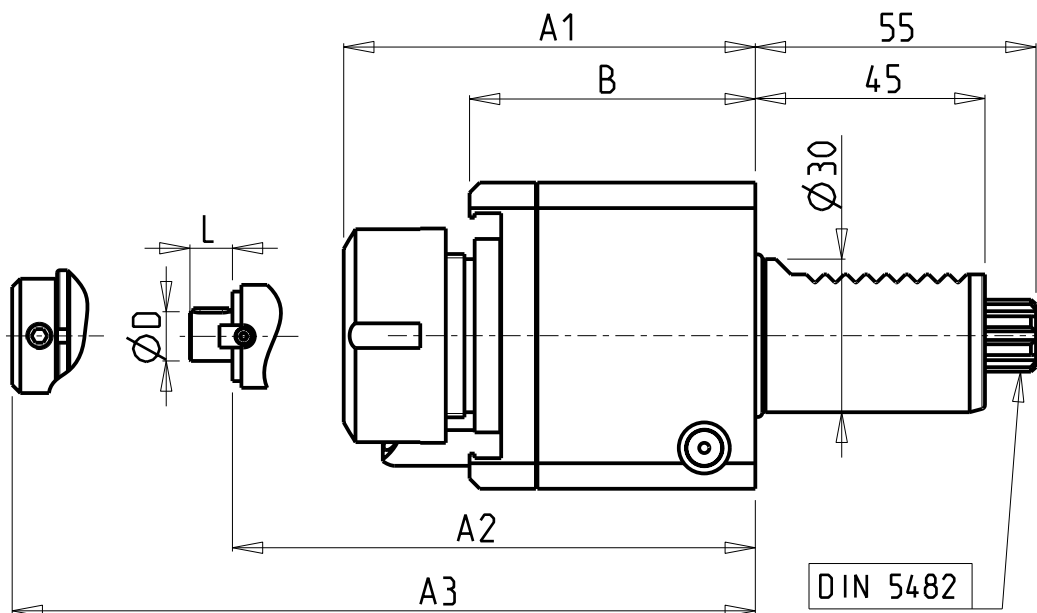

- Chiave inclusa
- Key included
- Schlüssel inbegriffen

Cod. MT	Mandrino Spindle Spindel	I	RPM	Coppia Max Max Torque Max Drehmoment	Lubrificazione int. Coolant through Innenkuehlung	Lubrificazione est. Ext. coolant Aussekuehlung	ØD	L	A1	A2	A3	B	CHIAVI NON INCLUDE Keys not included Schlüssel nicht inbegriffen		
SAU0170125	ER25	1:1	6000	32Nm		X			80.66			56	-	CHSTER25	OKU0290009 *
SAU0171125	ER25	1:1	6000	32Nm	P=30bar	X			94.66			70	-	CHSTER25	OKU0290009 *
SAU0170225	ERA25	1:1	6000	32Nm		X			61			56	CHUB27	CHTAER25ZC *	OKU0290009 *
SAU0171225	ERA25	1:1	6000	32Nm	P=30bar	X			75			70	CHUB27	CHTAER25ZC *	OKU0290009 *
SAU0170316	WELDON16	1:1	6000	32Nm		X					66.5	56	-	-	-
SAU0171316	WELDON16	1:1	6000	32Nm	P=30bar	X					80	70	-	-	-
SAU0170416	Ø16x17	1:1	6000	32Nm		X	16	17		59.5		56	-	CH_VTCROCE_M08 *	OKU0290009 *
SAU0170422	Ø22x19	1:1	6000	32Nm		X	22	19		61.5		56	-	CH_VTCROCE_M10 *	OKU0290009 *

SAUTER  
VDI 30

MODULO MOTORIZZATO ASSIALE VDI30 DIN 5482  
Axial driven tool VDI30 DIN 5482  
Axial angetriebenes Werkzeug VDI30 DIN 5482

Subject to change without notice.

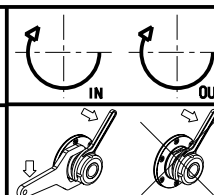

**M.T. srl**  
Via Casino Albini 480  
Tel. 0541/956034-957884  
Fax 0541/956341  
47842 S. GIOVANNI IN M. (RN)  
e-mail: mtma@mtmarchetti.com  
http://www.mtmarchetti.com

PRODUZIONE MODULI ROTANTI



PAGINA SAU014-2-00

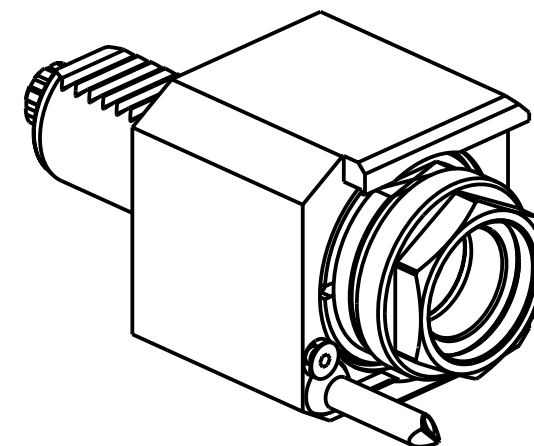
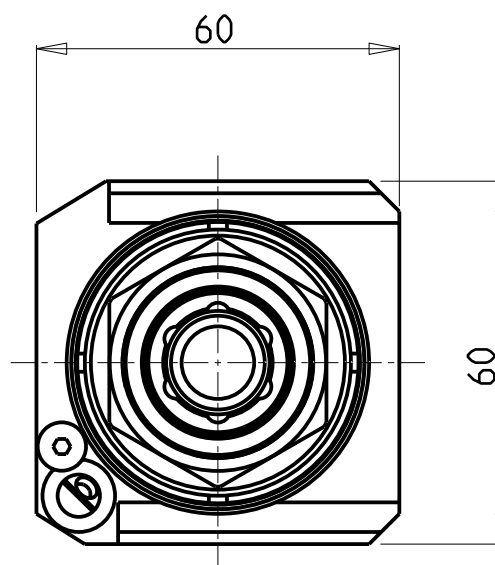
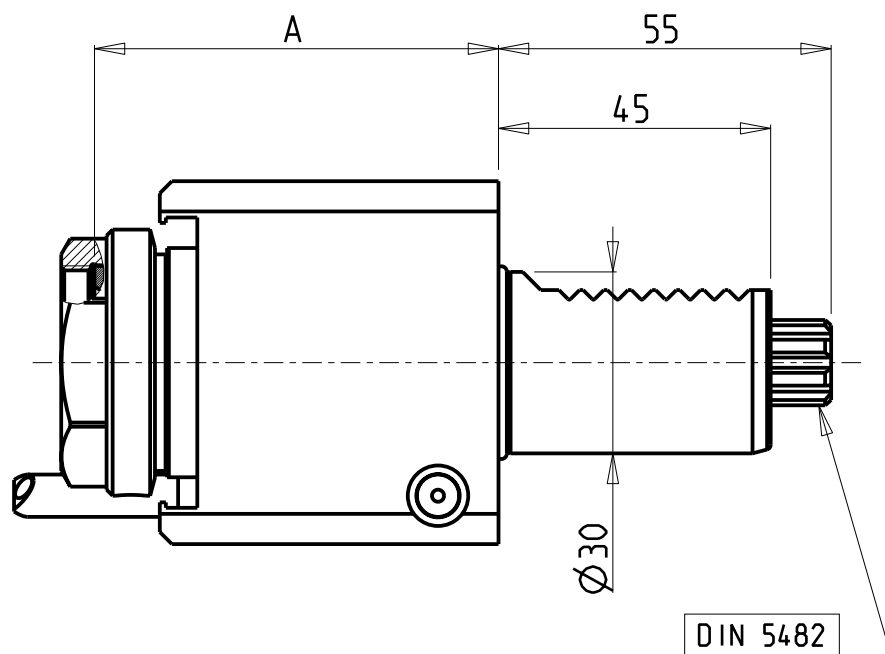

- Chiave inclusa
- Key included
- Schluessel inbegriffen

PER PORTAUTENSILI MODULARI MTSK-32 VEDI PAG. TBL300-1-32  
 FOR MTSK-32 QUICK CHANGE TOOLHOLDERS CLAMPINGS SEE PAGE TBL300-1-32  
 FUER MTSK-32 MODULARE WERKZEUGAUFNAHMEN SIEHE SEITE TBL300-1-32

Cod. MT	Mandrino Spindle Spindel	I	RPM	Coppia Max Max Torque Max Drehmoment	Lubrificazione int. Coolant through Innenkuehlung	Lubrificazione est. Ext. coolant Aussenkuehlung	A	CHIAVI NON INCLUDE Keys not included Schluessel nicht einbegriffen	
SAU0900132	MTSK-32	1:1	6000	40Nm	-	X	66.8	CHUB36	OKU0290009 ■
SAU0900232	MTSK-32	1:1	6000	40Nm	P=30bar	X	80.8	CHUB36	OKU0290009 ■

SAUTER  
VDI 30

MODULO MOTORIZZATO ASSIALE MTSK VDI30 DIN 5482  
 Axial MTSK driven tool VDI30 DIN 5482  
 Axial MTSK angetriebenes Werkzeug VDI30 DIN 5482

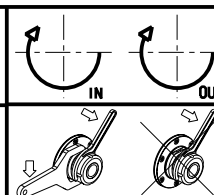

**M.T. srl**  
 Via Casino Albini 480  
 Tel. 0541/956034-957884  
 Fax 0541/956341  
 47842 S. GIOVANNI IN M. (RN)  
 e-mail: mtma@mtmarchetti.com  
 http://www.mtmarchetti.com

PRODUZIONE MODULI ROTANTI



PAGINA SAU014-2-00-K

Subject to change without notice.

10/2018

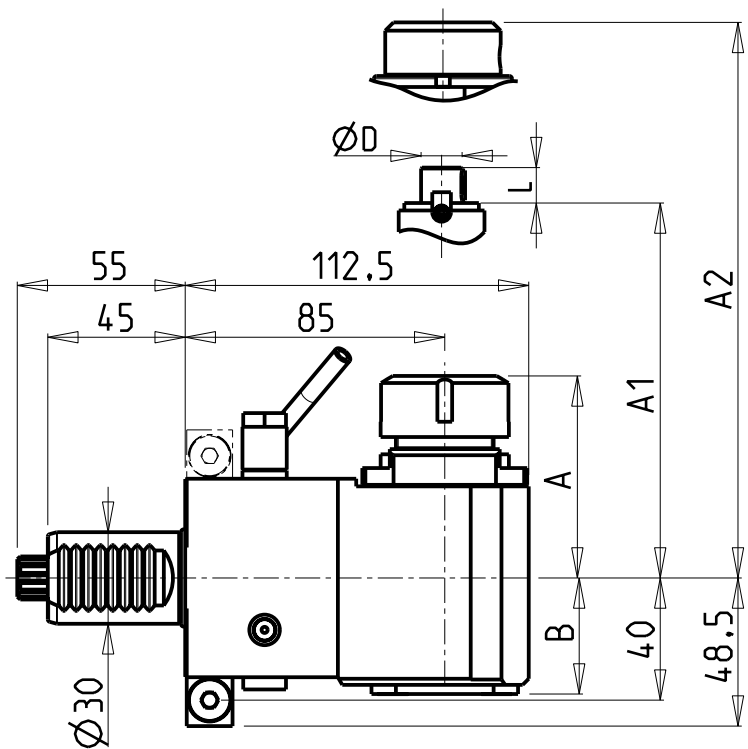

versione dx  
right version  
version rechts

versione sx  
left version  
version links

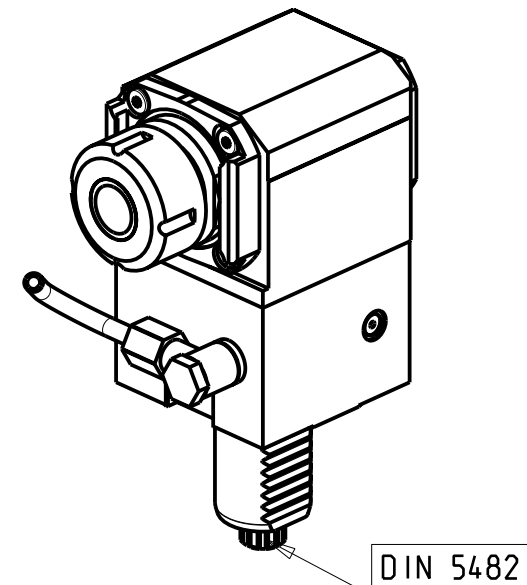
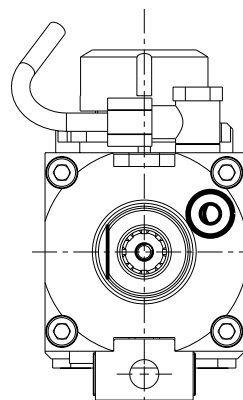
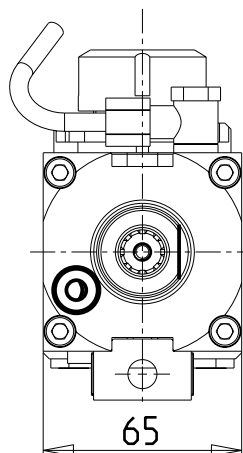

- Chiave inclusa
- Key included
- Schluessel inbegriffen

Cod. MT		Mandrino Spindel Spindel	I	RPM	Coppia Max Max Torque Max Drehmoment	Lubrificazione int. Coolant through Innenkuehlung	Lubrificazione est. Ext. coolant Aussenkuehlung	ØD	L	A	A1	A2	B	CHIAVI NON INCLUDE Keys not included Schluessel nicht einbegriffen	
versione dx right version version rechts	versione sx left version version links														
SAU0180125	SAU0181125	ER25	1:1	6000	32Nm	-	X	-	-	66.2	-	-	38	OKU0290009	CHSTER25
SAU0180225	SAU0181225	ER25	1:1	6000	32Nm	P=70bar	X	-	-	66.2	-	-	48	OKU0290009	CHSTER25
SAU0180316	SAU0181316	WELDON16	1:1	6000	32Nm	-	X	-	-	-	-	54.5	38	-	-
SAU0180416	SAU0181416	Ø16x17	1:1	6000	32Nm	-	X	16	17	-	45	-	38	OKU0290009	CH_VTCROCE_M08
SAU0180422	SAU0181422	Ø22x19	1:1	6000	32Nm	-	X	22	19	-	47	-	38	OKU0290009	CH_VTCROCE_M10

**SAUTER**  
VDI 30  
MODULO MOTORIZZATO RADIALE VDI30 DIN 5482  
Radial driven tool VDI30 DIN 5482  
Radial angetriebenes Werkzeug VDI30 DIN 5482

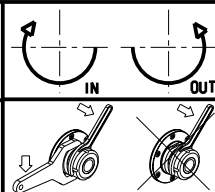

**M.T. srl**  
Via Casino Albini 480  
Tel. 0541/956034-957884  
Fax 0541/956341  
47842 S. GIOVANNI IN M. (RN)  
e-mail: mtma@mtmarchetti.com  
http://www.mtmarchetti.com

PRODUZIONE MODULI ROTANTI  
  
PAGINA SAU015-2-00

Subject to change without notice.

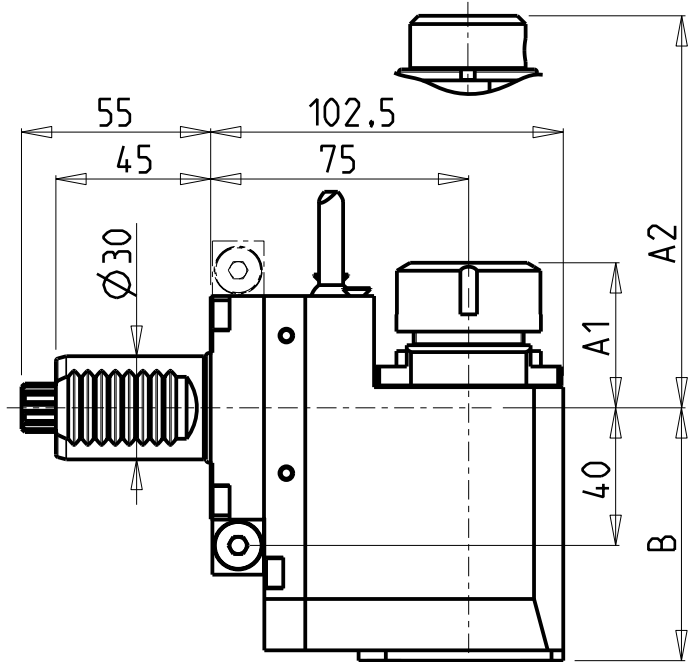

versione dx  
right version  
version rechts

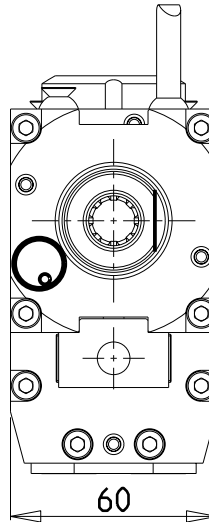

versione sx  
left version  
version links

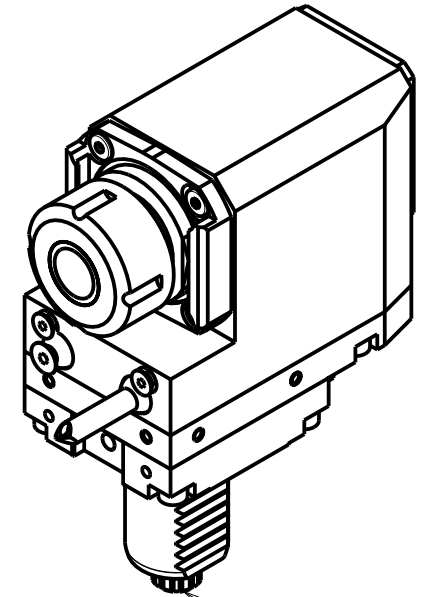
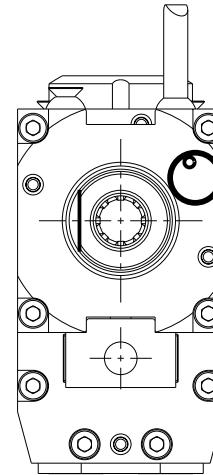

DIN 5482

Cod. MT		Mandrino Spindle Spindel	I	RPM	Coppia Max Max Torque Max Drehmoment	Lubrificazione int. Coolant through Innenkuehlung	Lubrificazione est. Ext. coolant Aussenkuehlung	A1	A2	B	CHIAVI NON INCLUDE Keys not included Schluessel nicht einbegriffen	
versione dx right version version rechts	versione sx left version version links											
SAU0200120	SAU0201120	ER20	1:1	6000	32Nm	-	X	41.16	-	73.5	-	CHSTER20 OKU0290009
SAU0200320	SAU0201320	ERA20	1:1	6000	32Nm	-	X	24.5	-	73.5	CHUB22	CHTAER20ZC OKU0290009
SAU0200420	SAU0201420	ERA20	1:1	6000	32Nm	P=70bar	X	24.5	-	83.5	CHUB22	CHTAER20ZC OKU0290009
SAU0200125	SAU0201125	ER25	1:1	6000	32Nm	-	X	42.16	-	73.5	-	CHSTER25 OKU0290009
SAU0200225	SAU0201225	ER25	1:1	6000	32Nm	P=70bar	X	42.16	-	83.5	-	CHSTER25 OKU0290009
SAU0200325	SAU0201325	ERA25	1:1	6000	32Nm	-	X	28.5	-	73.5	CHUB27	CHTAER25ZC OKU0290009
SAU0200425	SAU0201425	ERA25	1:1	6000	32Nm	P=70bar	X	28.5	-	83.5	CHUB27	CHTAER25ZC OKU0290009
SAU0200516	SAU0201516	WELDON16	1:1	6000	32Nm	-	X	-	27.5	73.5	-	-

- Chiave inclusa
- Key included
- Schluessel inbegriffen

SAUTER  
VDI 30

MODULO MOTORIZZATO RADIALE ARRETRATO VDI30 DIN 5482 H=75mm  
Radial rear-set driven tool VDI30 DIN 5482 H=75mm  
Radial angetriebenes Werkzeug zurueckversetzt VDI30 DIN 5482 H=75mm

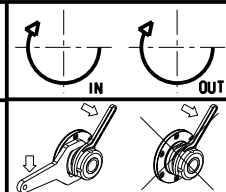

**M.T. srl**  
Via Casino Albini 480  
Tel. 0541/956034-957884  
Fax 0541/956341  
47842 S. GIOVANNI IN M. (RN)  
e-mail: mtma@mtmarchetti.com  
http://www.mtmarchetti.com

PRODUZIONE MODULI ROTANTI



PAGINA SAU015-2-60

Subject to change without notice.

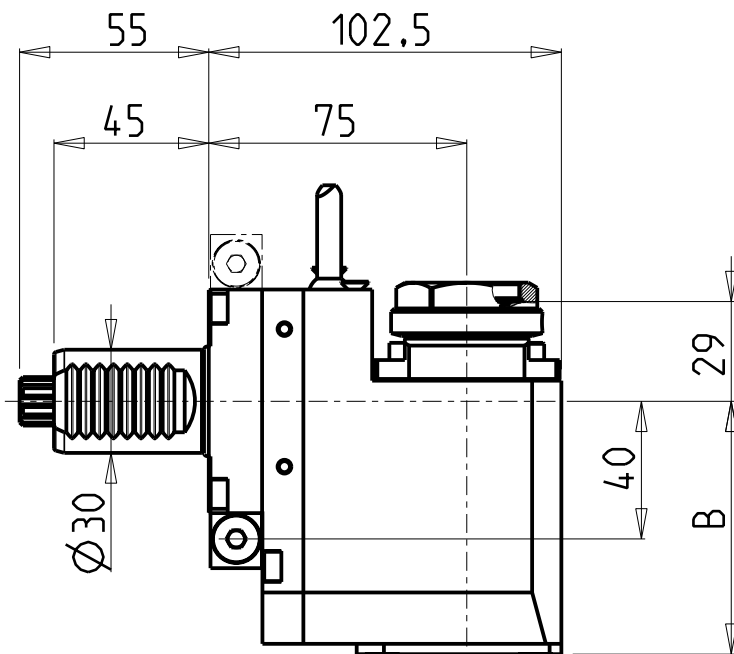

versione dx  
right version  
version rechts

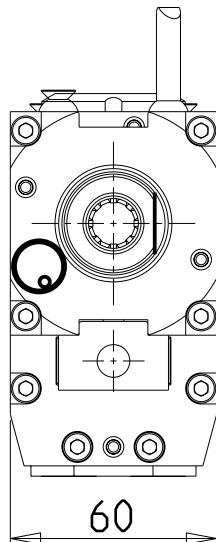

versione sx  
left version  
version links

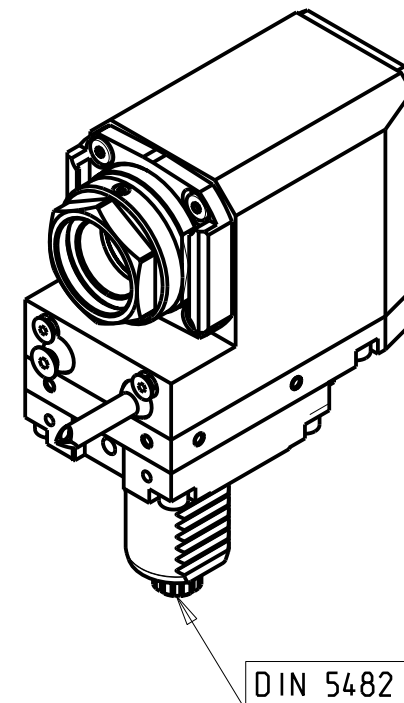
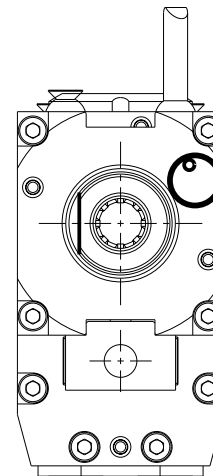

DIN 5482

PER PORTAUTENSILI MODULARI MTSK-32 VEDI PAG. TBL300-1-32  
FOR MTSK-32 QUICK CHANGE TOOLHOLDERS CLAMPINGS SEE PAGE TBL300-1-32  
FUER MTSK-32 MODULARE WERKZEUGAUFNAHMEN SIEHE SEITE TBL300-1-32

Cod. MT		Mandrino Spindle Spindel	I	RPM	Coppia Max Max Torque Max Drehmoment	Lubrificazione int. Coolant through Innenkuehlung	Lubrificazione est. Ext. coolant Aussenkuehlung	B	CHIAVI NON INCLUSE Keys not included Schlüssel nicht einbegriffen	
versione dx right version version rechts	versione sx left version version links								CHUB36	OKU0290009 •
SAU0670132	SAU0671132	MTSK-32	1:1	6000	32Nm	-	X	73.5	CHUB36	OKU0290009 •
SAU0670232	SAU0671232	MTSK-32	1:1	6000	32Nm	P=70bar	X	83.5	CHUB36	OKU0290009 •

- Chiave inclusa
- Key included
- Schlüssel inbegriffen

SAUTER  
VDI 30

MODULO MOTORIZZATO RADIALE ARRETRATO MTSK VDI30 DIN 5482 H=75mm  
Radial MTSK rear-set driven tool VDI30 DIN 5482 H=75mm  
Radial MTSK angetriebenes Werkzeug zurueckversetzt VDI30 DIN 5482 H=75mm

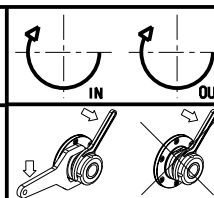

**M.T. srl**  
Via Casino Albini 480  
Tel. 0541/956034-957884  
Fax 0541/956341  
47842 S. GIOVANNI IN M. (RN)  
e-mail: mtma@mtmarchetti.com  
http://www.mtmarchetti.com

PRODUZIONE MODULI ROTANTI



PAGINA SAU015-2-60-K

Subject to change without notice.

10/2018

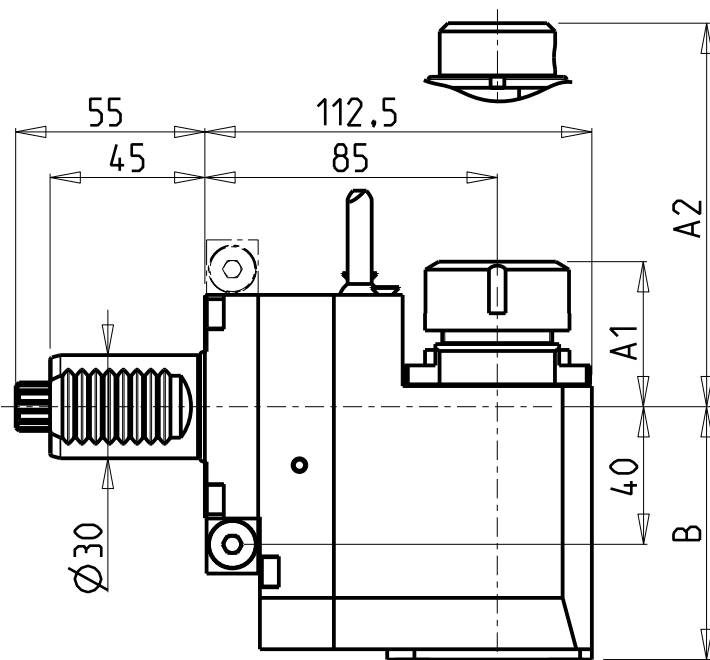

versione dx  
right version  
version rechts

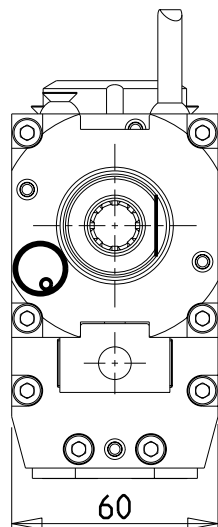

versione sx  
left version  
version links

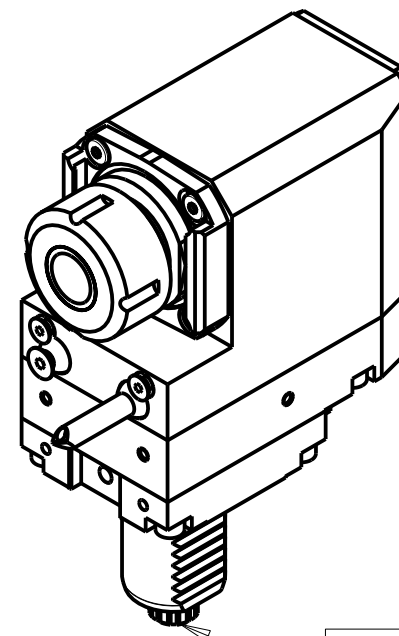
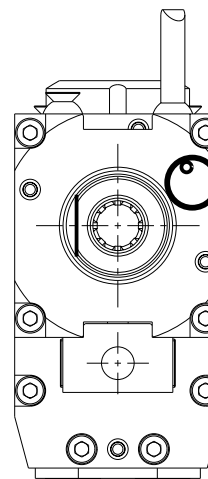

DIN 5482

Cod. MT		Mandrino Spindle Spindel	I	RPM	Coppia Max Max Torque Max Drehmoment	Lubrificazione int. Coolant through Innenkuehlung	Lubrificazione est. Ext. coolant Aussenkuehlung	A1	A2	B	CHIAVI NON INCLUDE Keys not included Schluessel nicht einbegriffen	
versione dx right version version rechts	versione sx left version version links											
SAU0210120	SAU0211120	ER20	1:1	6000	32Nm	-	X	41.16	-	73.5	-	CHSTER20 OKU0290009
SAU0210320	SAU0211320	ERA20	1:1	6000	32Nm	-	X	24.5	-	73.5	CHUB22	CHTAER20ZC OKU0290009
SAU0210420	SAU0211420	ERA20	1:1	6000	32Nm	P=70bar	X	24.5	-	83.5	CHUB22	CHTAER20ZC OKU0290009
SAU0210125	SAU0211125	ER25	1:1	6000	32Nm	-	X	42.16	-	73.5	-	CHSTER25 OKU0290009
SAU0210225	SAU0211225	ER25	1:1	6000	32Nm	P=70bar	X	42.16	-	83.5	-	CHSTER25 OKU0290009
SAU0210325	SAU0211325	ERA25	1:1	6000	32Nm	-	X	28.5	-	73.5	CHUB27	CHTAER25ZC OKU0290009
SAU0210425	SAU0211425	ERA25	1:1	6000	32Nm	P=70bar	X	28.5	-	83.5	CHUB27	CHTAER25ZC OKU0290009
SAU0210516	SAU0211516	WELDON16	1:1	6000	32Nm	-	X	-	27.5	73.5	-	-

- Chiave inclusa
- Key included
- Schluessel inbegriffen

SAUTER  
VDI 30

MODULO MOTORIZZATO RADIALE ARRETRATO VDI30 DIN 5482 H=85mm  
Radial rear-set driven tool VDI30 DIN 5482 H=85mm  
Radial angetriebenes Werkzeug zurueckversetzt VDI30 DIN 5482 H=85mm

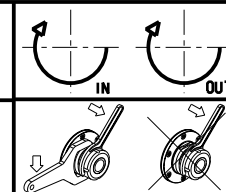

**M.T. srl**  
Via Casino Albini 480  
Tel. 0541/956034-957884  
Fax 0541/956341  
47842 S. GIOVANNI IN M. (RN)  
e-mail: mtma@mtmarchetti.com  
http://www.mtmarchetti.com

PRODUZIONE MODULI ROTANTI



PAGINA SAU015-2-70

Subject to change without notice.

10/2018



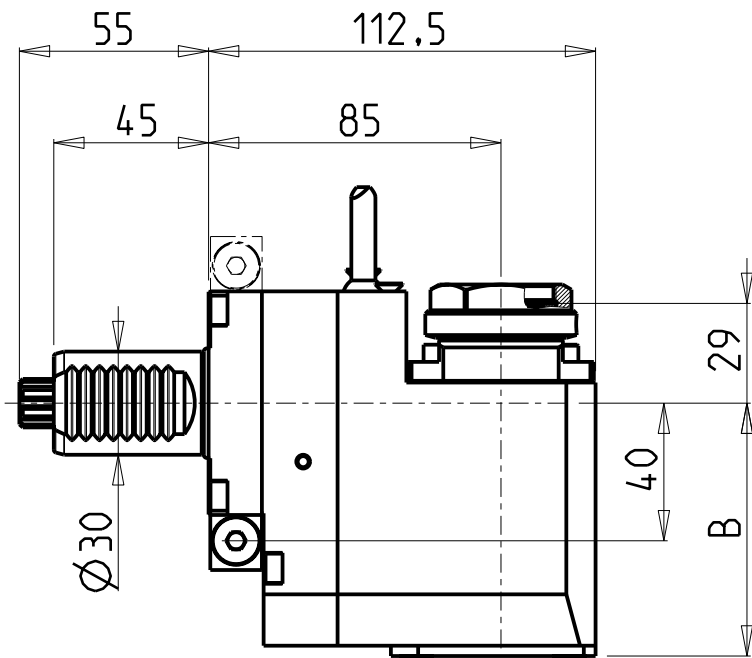

versione dx  
right version  
version rechts

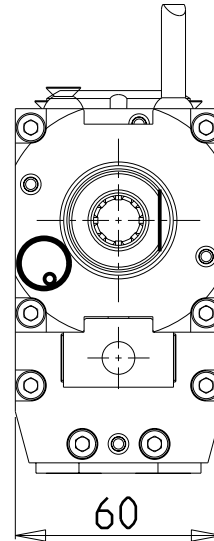

versione sx  
left version  
version links

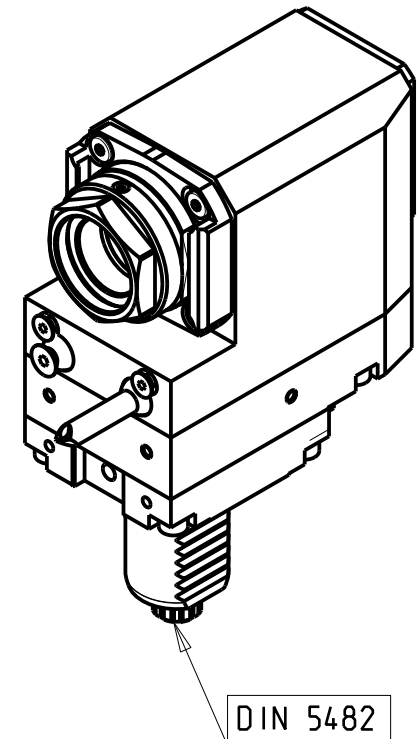
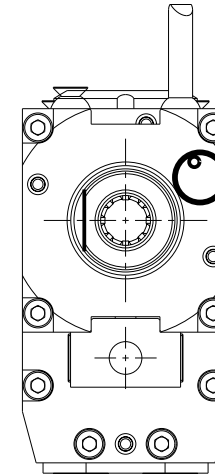

DIN 5482

- Chiave inclusa
- Key included
- Schlüssel inbegriffen

PER PORTAUTENSILI MODULARI MTSK-32 VEDI PAG. TBL300-1-32  
FOR MTSK-32 QUIK CHANGE TOOLHOLDERS CLAMPINGS SEE PAGE TBL300-1-32  
FUER MTSK-32 MODULARE WERKZEUGAUFNAHMEN SIEHE SEITE TBL300-1-32

Cod. MT		Mandrino Spindle Spindel	I	RPM	Coppia Max Max Torque Max Drehmoment	Lubrificazione int. Coolant through Innenkuehlung	Lubrificazione est. Ext. coolant Aussenkuehlung	B	CHIAVI NON INCLUSE Keys not included Schlüssel nicht einbegriffen	
versione dx right version version rechts	versione sx left version version links								CHUB36	OKU0290009 •
SAU0680132	SAU0681132	MTSK-32	1:1	6000	32Nm	-	X	73.5	CHUB36	OKU0290009 •
SAU0680232	SAU0681232	MTSK-32	1:1	6000	32Nm	P=70bar	X	83.5	CHUB36	OKU0290009 •

SAUTER  
VDI 30

MODULO MOTORIZZATO RADIALE ARRETRATO MTSK VDI30 DIN 5482 H=85mm  
Radial MTSK rear-set driven tool VDI30 DIN 5482 H=85mm  
Radial MTSK angetriebenes Werkzeug zurueckversetzt VDI30 DIN 5482 H=85mm

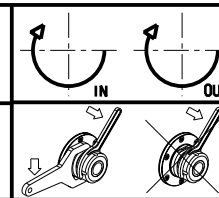

**M.T. srl**  
Via Casino Albini 480  
Tel. 0541/956034-957884  
Fax 0541/956341  
47842 S. GIOVANNI IN M. (RN)  
e-mail: mtma@mtmarchetti.com  
http://www.mtmarchetti.com

PRODUZIONE MODULI ROTANTI



PAGINA SAU015-2-70-K

Subject to change without notice.

10/2018

