

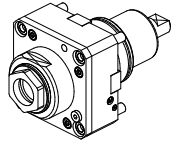

		PAGINA Page Seite
MODULO MOTORIZZATO RADIALE Radial driven tool Radial angetriebenes Werkzeug		SMG010.3.00
MODULO MOTORIZZATO RADIALE MTSK Radial MTSK driven tool Radial MTSK angetriebenes Werkzeug		SMG010.3.00.K
MODULO MOTORIZZATO RADIALE DISASSATO IN Z 110mm Radial driven tool re-directed in Z by 110mm Radial angetriebenes Werkzeug achsversetzt in Z um 110mm		SMG030.3.10
MODULO MOTORIZZATO RADIALE RIDOTTO I=2:1 DISASSATO IN Z 110mm Radial geared-down I=2:1 driven tool re-directed in Z by 110mm Radial angetriebenes Werkzeug untersetzt I=2:1 achsversetzt in Z um 110mm		SMG030.3.20
MODULO MOTORIZZATO ASSIALE H=85mm Axial driven tool H=85mm Axial angetriebenes Werkzeug H=85mm		SMG150.3.10
MODULO MOTORIZZATO ASSIALE MTSK H=85mm Axial MTSK driven tool H=85mm Axial MTSK angetriebenes Werkzeug H=85mm		SMG150.3.10.K
MODULO MOTORIZZATO ASSIALE H=110mm Axial driven tool H=110mm Axial angetriebenes Werkzeug H=110mm		SMG150.3.20
MODULO MOTORIZZATO ASSIALE MTSK H=110mm Axial MTSK driven tool H=110mm Axial MTSK angetriebenes Werkzeug H=110mm		SMG150.3.20.K
MODULO MOTORIZZATO ASSIALE RIDOTTO I=2:1 H=85mm Axial geared-down I=2:1 driven tool Axial angetriebenes Werkzeug untersetzt I=2:1		SMG190.3.10
MODULO MOTORIZZATO ASSIALE MTSK RIDOTTO I=2:1 H=85mm Axial MTSK geared-down I=2:1 driven tool Axial MTSK angetriebenes Werkzeug untersetzt I=2:1		SMG190.3.10.K
MODULO MOTORIZZATO ASSIALE RIDOTTO I=2:1 H=110mm Axial geared-down I=2:1 driven tool H=110mm Axial angetriebenes Werkzeug untersetzt I=2:1 H=110mm		SMG190.3.20
MODULO MOTORIZZATO ASSIALE MTSK RIDOTTO I=2:1 H=110mm Axial MTSK geared-down I=2:1 driven tool H=110mm Axial MTSK angetriebenes Werkzeug untersetzt I=2:1 H=110mm		SMG190.3.20.K

		PAGINA Page Seite
<p>MODULO MOTORIZZATO ASSIALE MOLTIPLICATO 1:3 Axial geared-up 1=1:3 driven tool Axial angetriebenes Werkzeug uebersetzt 1=1:3</p>		SMG205.3.10
<p>MODULO MOTORIZZATO ORIENTABILE +/-90° +/-90° adjustable angle driven tool Angetriebenes Werkzeug schwenkbar +/-90°</p>		SMG339.3.00
<p>MODULO MOTORIZZATO PORTACREATORE MAGGIORATO Reinforced driven gear hobber Angetriebenes Zahnradwaelzfraes-Werkzeug vergroessert</p>		SMG340.3.60
<p>MODULO MOTORIZZATO PORTACREATORE (TAGLIA GRANDE) Driven gear hobber (big size) Angetriebenes Zahnradwaelzfraes-Werkzeug (grosse version)</p>		SMG340.3.80
<p>INTERFACCIA PER MODULI BMT-65 H=33mm BMT-65 tooling adapter cartridge H=33mm Adapter-Patrone fuer BMT-65 werkzeuge H=33mm</p>		SMG385.3.00
<p>PORTAUTENSILE RADIALE SINGOLO QD=32mm / QD=1 1/4" Radial single static tool QD=32mm / QD=1 1/4" Radial Single-Werkzeughalter QD=32mm / QD=1 1/4"</p>		SMG423.3.00
<p>PORTAUTENSILE ASSIALE SINGOLO QD=32mm / QD=1 1/4" Axial single static tool QD=32mm / QD=1 1/4" Axial Single-Werkzeughalter QD=32mm / QD=1 1/4"</p>		SMG552.3.00
<p>PORTAUTENSILE ASSIALE PER BARENO Ø80mm / Ø3" H=85mm Axial single boring bar holder Ø80mm / Ø3" H=85mm Axial Bohrhalter Ø80mm / Ø3" H=85mm</p>		SMG580.3.20

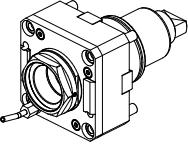
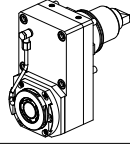
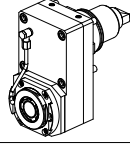
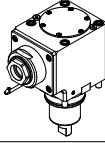
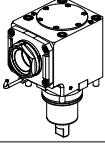
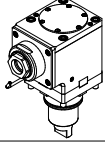
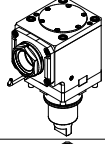
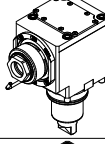
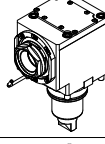
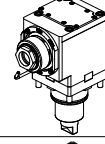
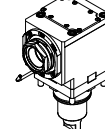
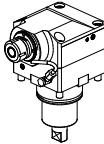

Cod. MT	Mandrino Spindle Spindel	I	RPM	Coppia Max Max Torque Max Drehmoment	Lubrificazione int. Coolant through Innenkuehlung	Lubrificazione est. Ext. coolant Aussenkuehlung	A	CHIAVI NON INCLUSE Keys not included Schluessel nicht einbegriffen	
DW01240150	ER A 50	1:1	3000	210Nm	-	X	40	CHUB50	CHUB74
DW00160250	ER A 50	1:1	3000	210Nm	P=30bar	X	28	CHUB50	CHUB74

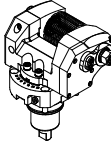
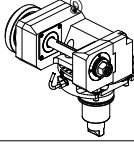
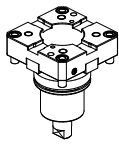
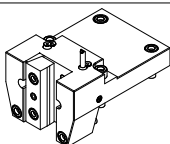
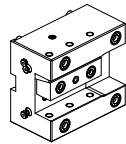
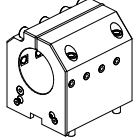
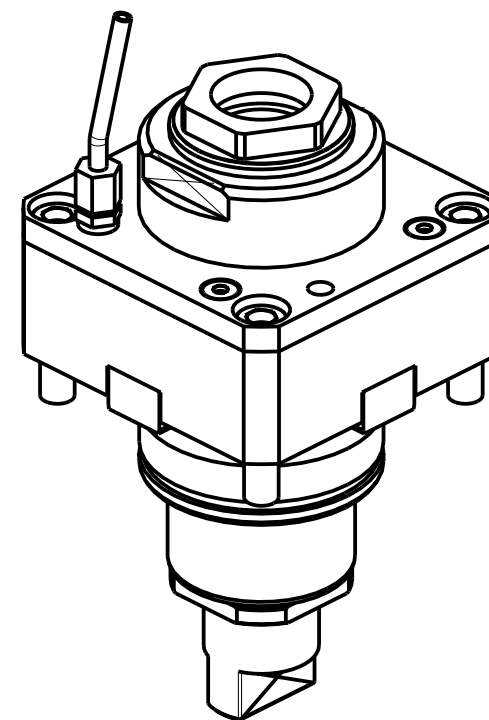
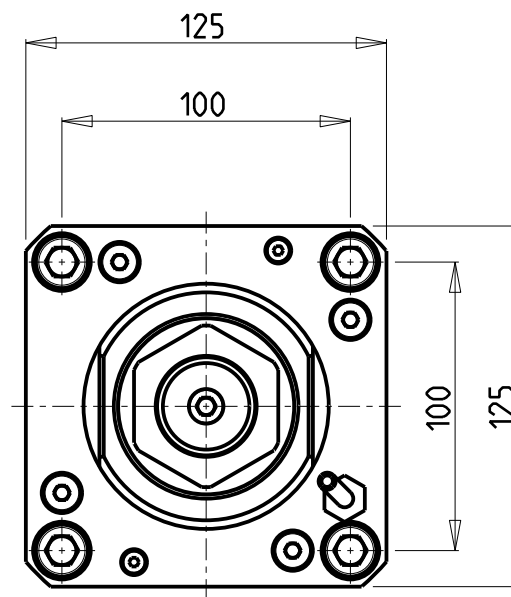
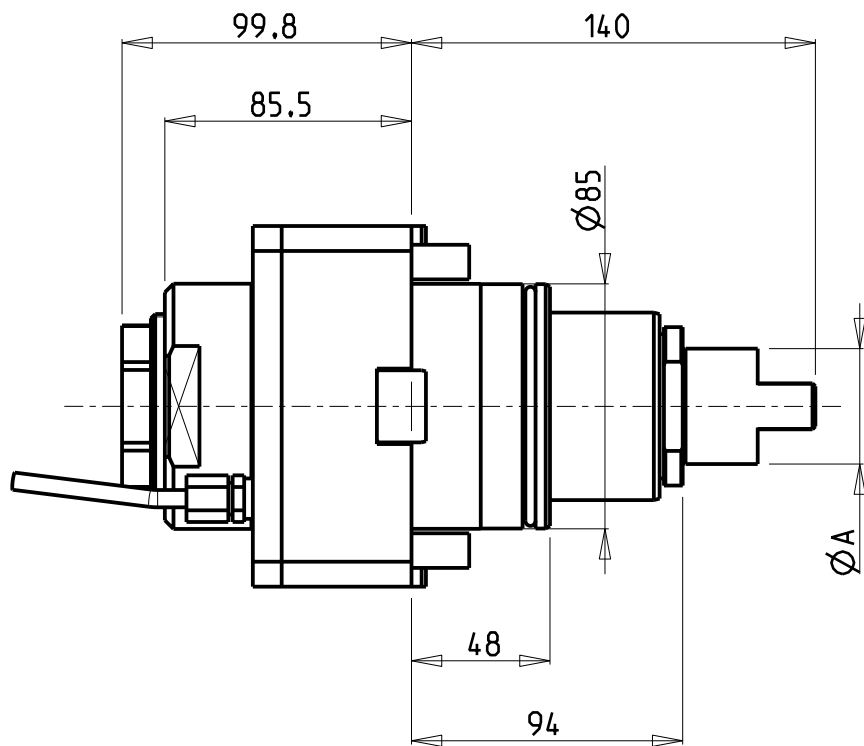
SAMSUNG

MOD: SL60/65 MC - PL60/65/70/80 MC - SLV1000M

MODULO MOTORIZZATO RADIALE

Radial driven tool

Radial angetriebenes Werkzeug

Subject to change without notice.

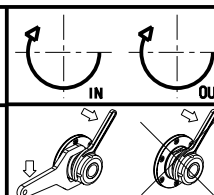

M.T. srl

Via Casino Albini 480
Tel. 0541/956034-957884
Fax 0541/956341

47842 S. GIOVANNI IN M. (RN)
e-mail: mtma@mtmarchetti.com
http://www.mtmarchetti.com

PRODUZIONE MODULI ROTANTI



PAGINA SMG010-3-00

10/2018

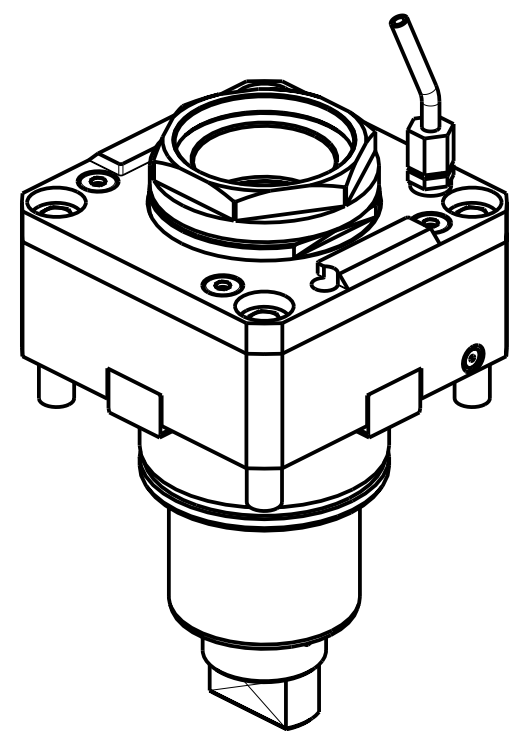
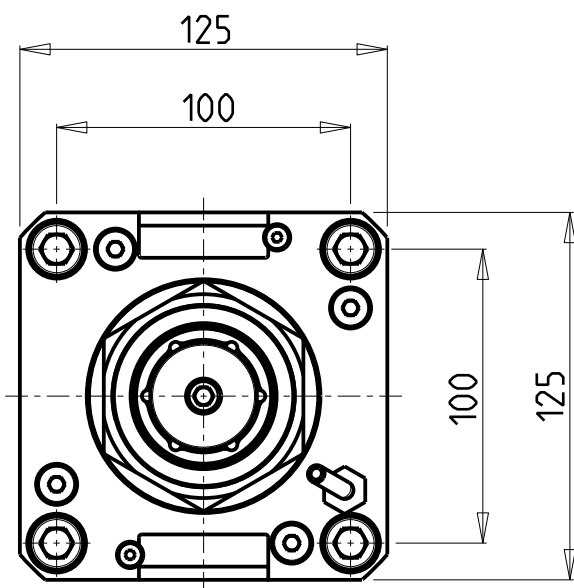
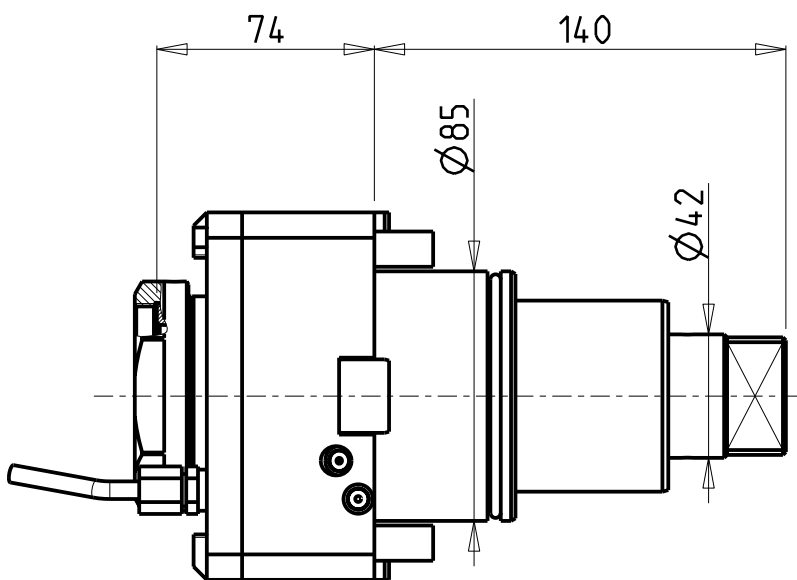

PER PORTAUTENSILI MODULARI MTSK-63 VEDI PAG. TBL300-1-63
 FOR MTSK-63 QUICK CHANGE TOOLHOLDERS CLAMPINGS SEE PAGE TBL300-1-63
 FUER MTSK-63 MODULARE WERKZEUGAUFNAHMEN SIEHE SEITE TBL300-1-63

Cod. MT	Mandrino Spindle Spindel	I	RPM	Coppia Max Max Torque Max Drehmoment	Lubrificazione int. Coolant through Innenkuehlung	Lubrificazione est. Ext. coolant Aussenkuehlung	CHIAVI NON INCLUSE Keys not included Schluessel nicht einbegriffen	
DW01750163	MTSK-63	1:1	3000	210Nm	-	X	CHUB68	NZL0010023 •
DW01750263	MTSK-63	1:1	3000	210Nm	P=30bar	X	CHUB68	NZL0010023 •

- Chiave inclusa
- Key included
- Schluessel inbegriffen

SAMSUNG
 MOD: SL60/65 MC - PL60/65/70/80 MC - SLV1000M

MODULO MOTORIZZATO RADIALE MTSK
 Radial MTSK driven tool
 Radial MTSK angetriebenes Werkzeug

Subject to change without notice.

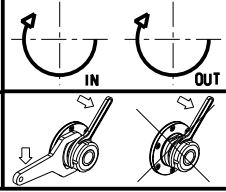

M.T. srl
 Via Casino Albini 480
 Tel. 0541/956034-957884
 Fax 0541/956341
 47842 S. GIOVANNI IN M. (RN)
 e-mail: mtma@mtmarchetti.com
 http://www.mtmarchetti.com

PRODUZIONE MODULI ROTANTI



PAGINA SMG010-3-00-K

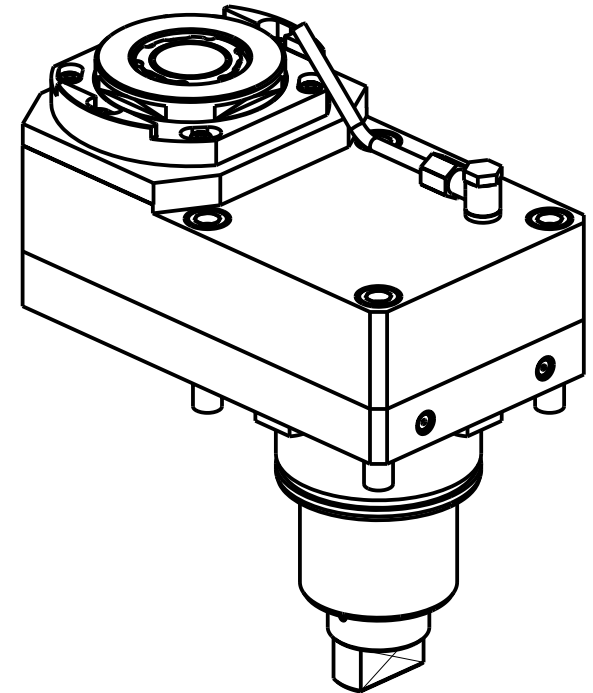
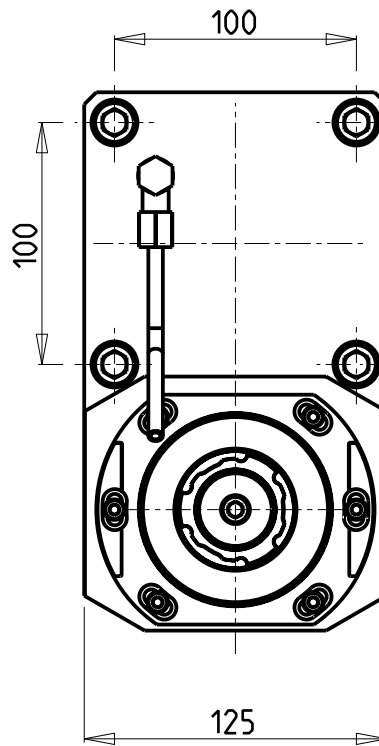
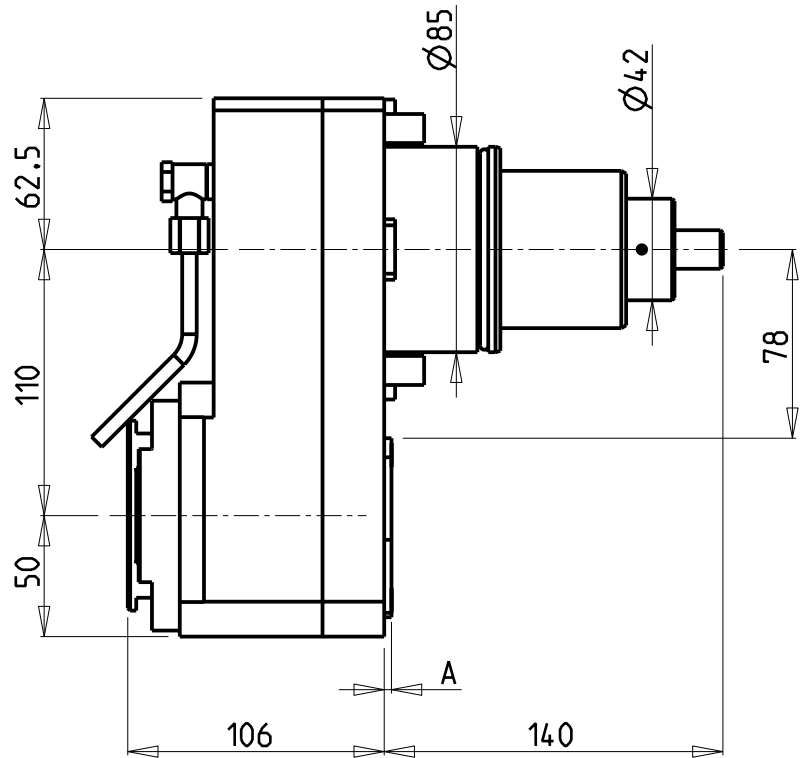

Cod. MT	Mandrino Spindle Spindel	I	RPM	Coppia Max Max Torque Max Drehmoment	Lubr.interna Coolant through Innenkuehlung	Lubr. esterna Ext. coolant Aussenkuehlung	A	CHIAVI NON INCLUSE Keys not included Schluessel nicht einbegriffen		
								CHUB36	NZL0010023	CHTAER40ZC
DW02121140	ERA40	1:1	3000	180Nm	-	X	3	CHUB36	NZL0010023	CHTAER40ZC
DW02121240	ERA40	1:1	3000	180Nm	P=70bar	X	14	CHUB36	NZL0010023	CHTAER40ZC

- Chiave inclusa
- Key included
- Schluessel inbegriffen

SAMSUNG
 MOD: SL60/65 MC - PL60/65/70/80 MC - SLV1000M

MODULO MOTORIZZATO RADIALE DISASSATO IN Z 110mm
 Radial driven tool re-directed in Z by 110mm
 Radial angetriebenes Werkzeug achsversetzt in Z um 110mm

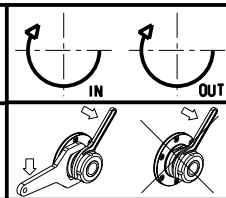

M.T. srl
 Via Casino Albini 480
 Tel. 0541/956034-957884
 Fax 0541/956341
 47842 S. GIOVANNI IN M. (RN)
 e-mail: mtma@mtmarchetti.com
 http://www.mtmarchetti.com

PRODUZIONE MODULI ROTANTI



PAGINA SMG030-3-10

Subject to change without notice.

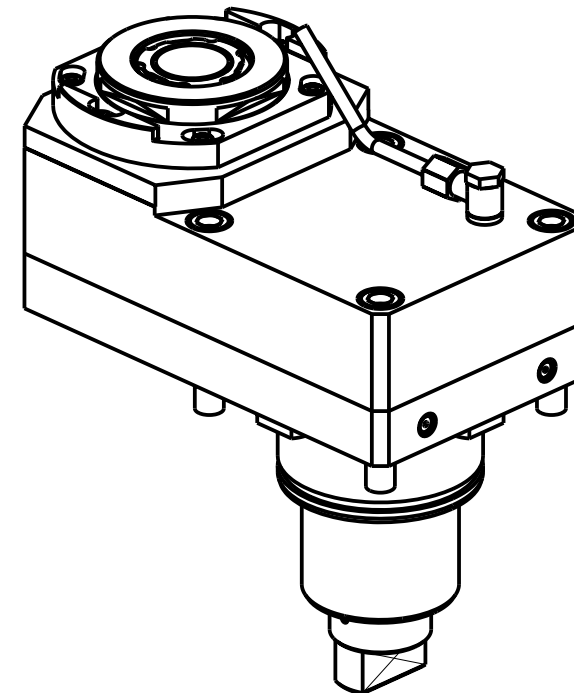
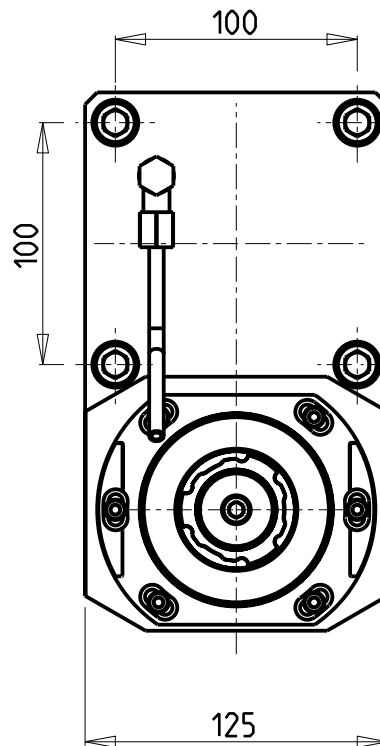
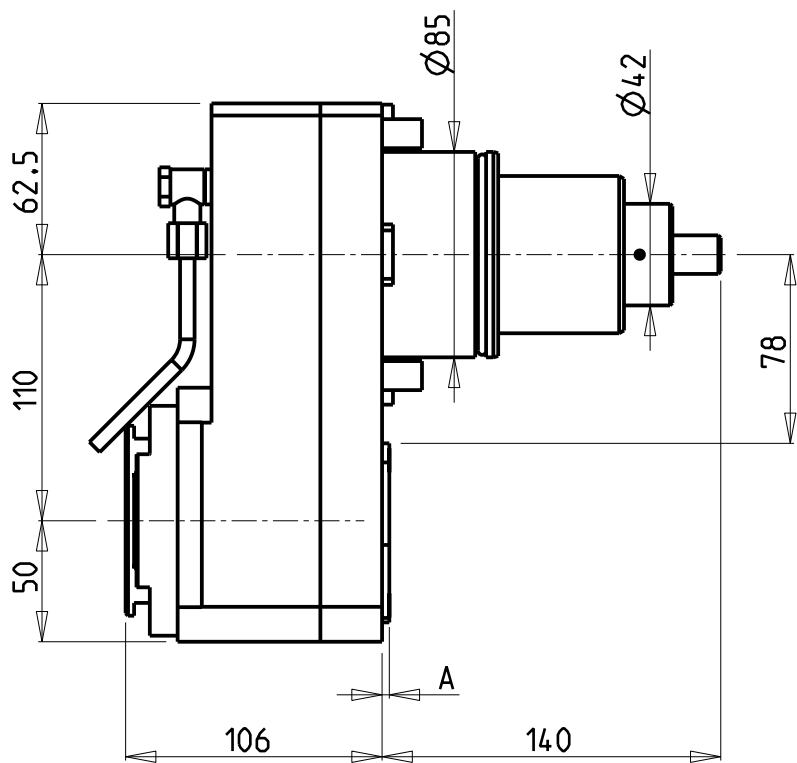

Cod. MT	Mandrino Spindle Spindel	I	RPM	Coppia Max Max Torque Max Drehmoment	Lubr.interna Coolant through Innenkuehlung	Lubr. esterna Ext. coolant Ausseinkuehlung	A	CHIAVI NON INCLUDE Keys not included Schluessel nicht einbegriffen		
DW 02122140	ERA40	2:1	1500	270Nm	-	X	3	CHUB36	NZL0010023	CHTAER40ZC
DW 02122240	ERA40	2:1	1500	270Nm	P=70bar	X	14	CHUB36	NZL0010023	CHTAER40ZC

- Chiave inclusa
- Key included
- Schluessel inbegriffen

SAMSUNG

MOD: SL60/65 MC - PL60/65/70/80 MC - SLV1000M

MODULO MOTORIZZATO RADIALE RIDOTTO I=2:1 DISASSATO IN Z 110mm

Radial geared-down I=2:1 driven tool re-directed in Z by 110mm

Radial angetriebenes Werkzeug untersetzt I=2:1 achsversetzt in Z um 110mm

Subject to change without notice.

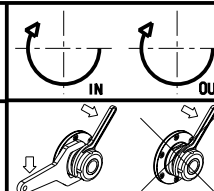

M.T. srl

Via Casino Albini 480
Tel. 0541/956034-957884
Fax 0541/956341

47842 S. GIOVANNI IN M. (RN)
e-mail: mtma@mtmarchetti.com
http://www.mtmarchetti.com

PRODUZIONE MODULI ROTANTI



PAGINA SMG030-3-20

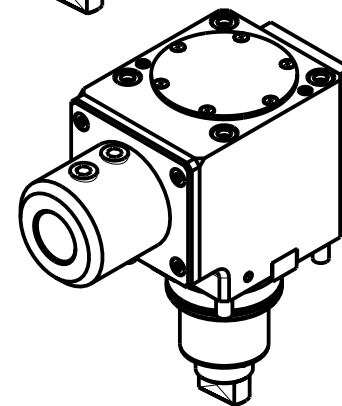
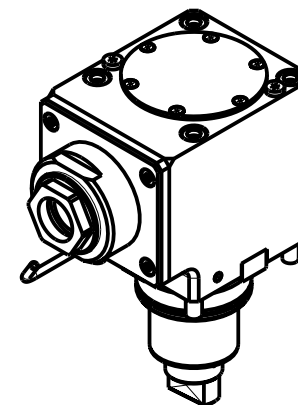
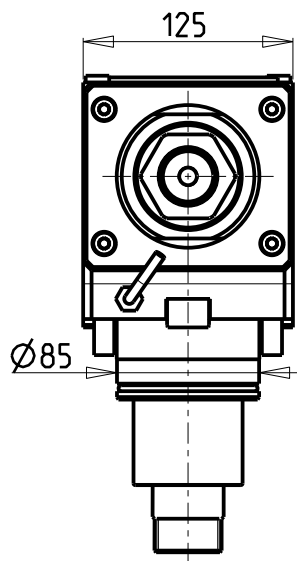
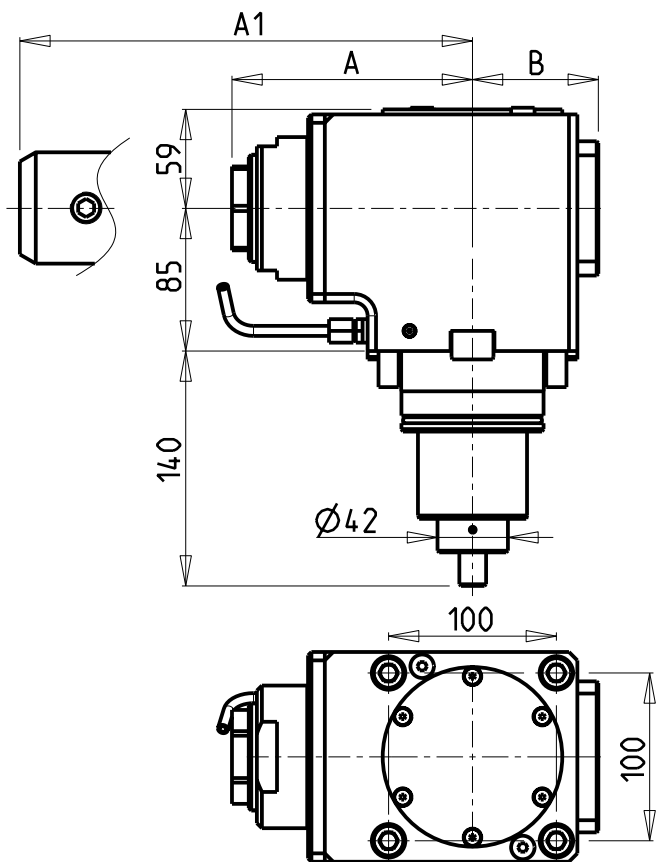

Cod. MT	Mandrino Spindle Spindel	I	RPM	Coppia Max Max Torque Max Drehmoment	Reversibile lato mandrino/contromandrino Reversible sub/main spindle side Umkehrbare Spindel-seite/ Gegenspindel-seite	Lubr.interna Coolant through Innenkuehlung	Lubr. esterna Ext. coolant Aussenkuehlung	A	A1	B	CHIAVI NON INCLUSE Keys not included Schlüssel nicht einbegriffen	
DW00150150	ER A 50	1:1	3000	210Nm	X		X	143.33	-	75	CHUB50	CHUB74
DW00151250	ER A 50	1:1	3000	210Nm	X	P=70bar	X	143.33	-	86	CHUB50	CHUB74
DW00150240	Weldon 40	1:1	3000	210Nm	X		X	-	175.5	75	-	-
DW00150140	Weldon 40	1:1	3000	210Nm	X	P=70bar	X	-	175.5	86	-	-

SAMSUNG

MOD: SL60/65 MC - PL60/65/70/80 MC

MODULO MOTORIZZATO ASSIALE H=85mm

Axial driven tool H=85mm

Axial angetriebenes Werkzeug H=85mm

Subject to change without notice.

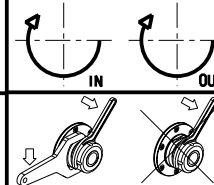

M.T. srl

Via Casino Albini 480
Tel. 0541/956034-957884

Fax 0541/956341

47842 S. GIOVANNI IN M. (RN)

e-mail: mtma@mtmarchetti.com

http://www.mtmarchetti.com

PRODUZIONE MODULI ROTANTI



PAGINA SMG150-3-10

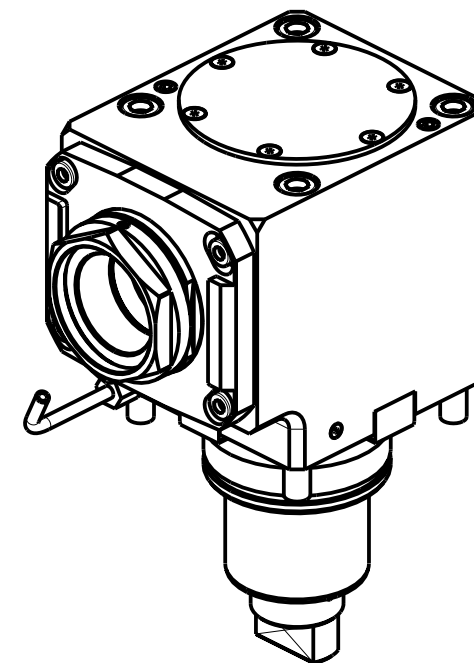
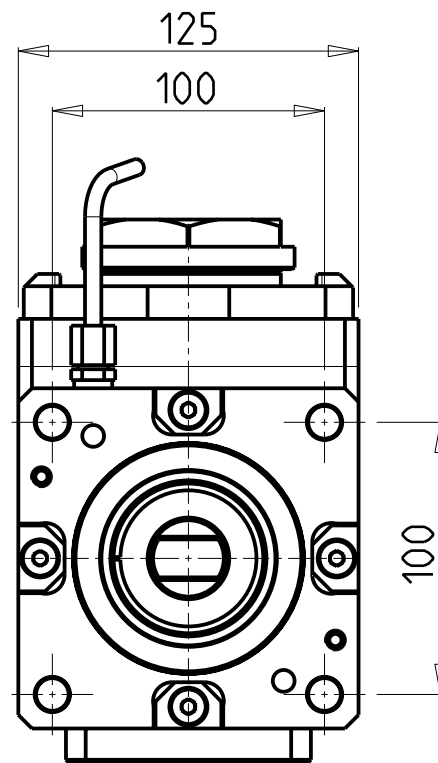
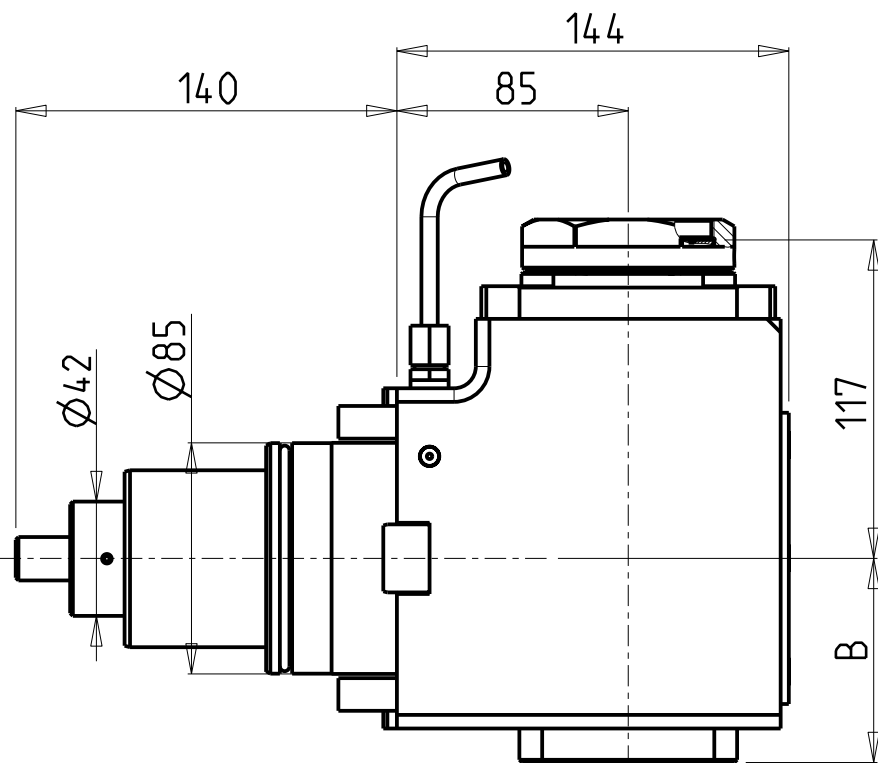

PER PORTAUTENSILI MODULARI MTSK-63 VEDI PAG. TBL300-1-63
 FOR MTSK-63 QUICK CHANGE TOOLHOLDERS CLAMPINGS SEE PAGE TBL300-1-63
 FUER MTSK-63 MODULARE WERKZEUGAUFNAHMEN SIEHE SEITE TBL300-1-63

Cod. MT	Mandrino Spindle Spindel	I	RPM	Coppia Max Max Torque Max Drehmoment	Reversibile lato mandrino/contromandrino Reversible sub/main spindle side Umkehrbare Spindel-seite/ Gegenspindel-seite	Lubr.interna Coolant through Innenkuehlung	Lubr. esterna Ext. coolant Aussenkuehlung	B	CHIAVI NON INCLUDE Keys not included Schluessel nicht einbegriffen	
DW01590163	MTSK-63	1:1	3000	210Nm	X	-	X	75	CHUB68	NZL0010023 ■
DW01590263	MTSK-63	1:1	3000	210Nm	X	P=70bar	X	86	CHUB68	NZL0010023 ■

- Chiave inclusa
- Key included
- Schluessel inbegriffen

SAMSUNG
 MOD: SL60/65 MC - PL60/65/70/80 MC

MODULO MOTORIZZATO ASSIALE MTSK H=85mm
 Axial MTSK driven tool H=85mm
 Axial MTSK angetriebenes Werkzeug H=85mm

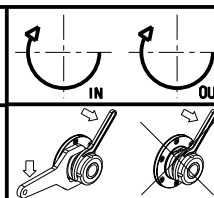

M.T. srl
 Via Casino Albini 480
 Tel. 0541/956034-957884
 Fax 0541/956341
 47842 S. GIOVANNI IN M. (RN)
 e-mail: mtma@mtmarchetti.com
 http://www.mtmarchetti.com

PRODUZIONE MODULI ROTANTI



PAGINA SMG150-3-10-K

Subject to change without notice.

10/2018

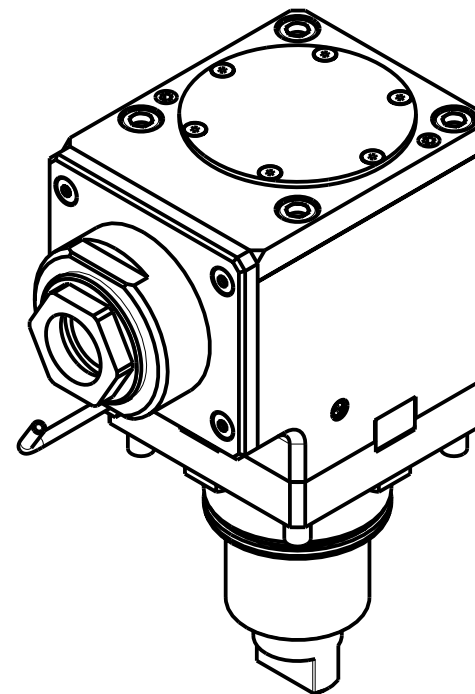
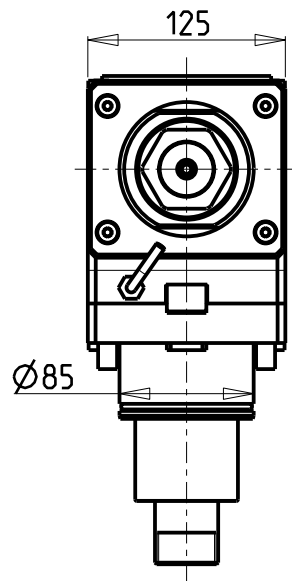
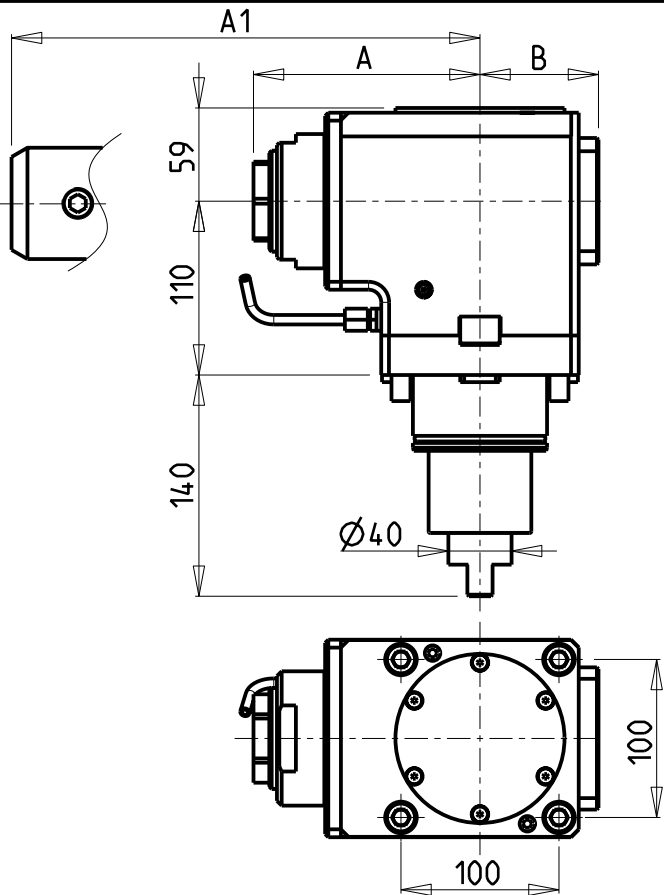

Cod. MT	Mandrino Spindle Spindel	I	RPM	Coppia Max Max Torque Max Drehmoment	Reversibile lato mandrino/contromandrino Reversible sub/main spindle side Umkehrbare Spindel-seite/ Gegenspindel-seite	Lubr.interna Coolant through Innenkuehlung	Lubr. esterna Ext. coolant Aussenkuehlung	A	A1	B	CHIAVI NON INCLUSE Keys not included Schluessel nicht einbegriffen	
DW01290150	ER A 50	1:1	3000	210Nm	X		X	143.33	-	75	CHUB50	CHUB74
DW01291250	ER A 50	1:1	3000	210Nm	X	P=70bar	X	143.33	-	86	CHUB50	CHUB74
DW01290240	Weldon 40	1:1	3000	210Nm	X		X	-	175.5	75	-	-
DW01290140	Weldon 40	1:1	3000	210Nm	X	P=70bar	X	-	175.5	86	-	-

SAMSUNG

MOD: SL60/65 MC - PL60/65/70/80 MC - SLV1000M

MODULO MOTORIZZATO ASSIALE H=110mm

Axial driven tool H=110mm

Axial angetriebenes Werkzeug H=110mm

Subject to change without notice.

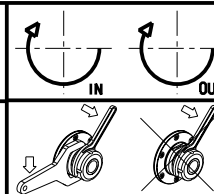

M.T. srl

Via Casino Albini 480
Tel. 0541/956034-957884
Fax 0541/956341

47842 S. GIOVANNI IN M. (RN)
e-mail: mtma@mtmarchetti.com
http://www.mtmarchetti.com

PRODUZIONE MODULI ROTANTI



PAGINA SMG150-3-20

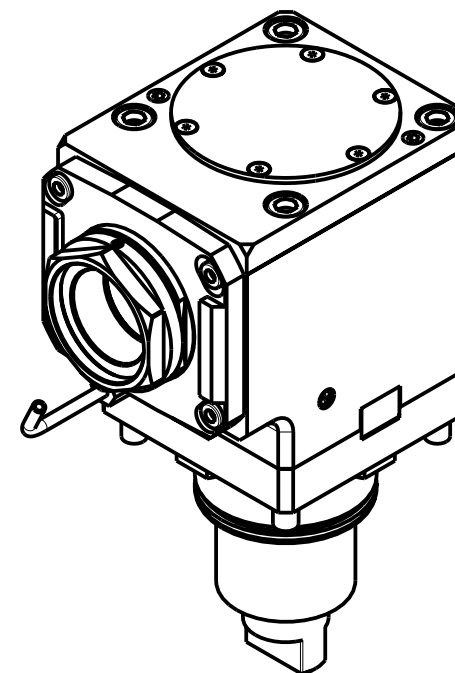
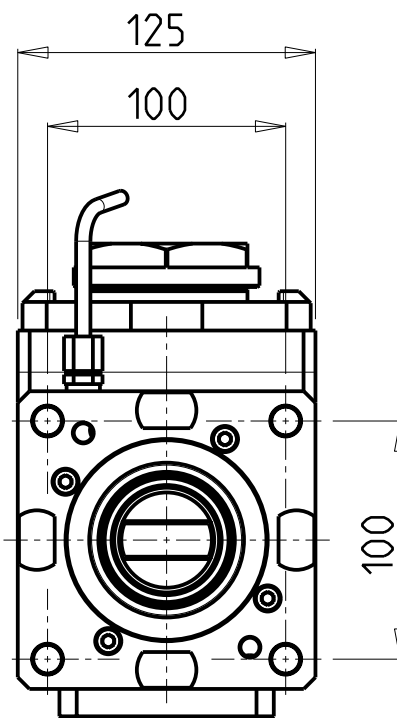
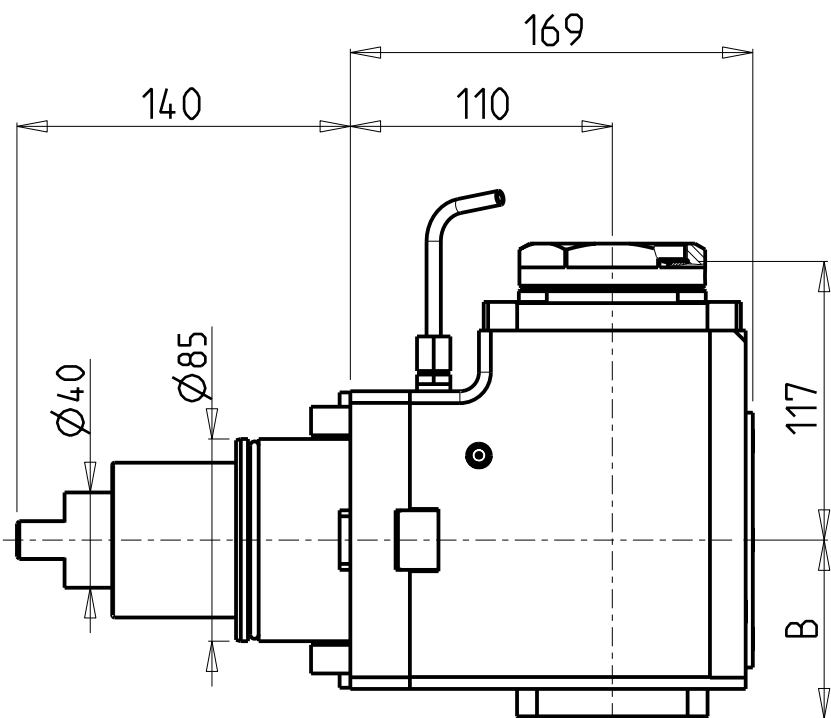

PER PORTAUTENSILI MODULARI MTSK-63 VEDI PAG. TBL300-1-63
 FOR MTSK-63 QUIK CHANGE TOOLHOLDERS CLAMPINGS SEE PAGE TBL300-1-63
 FUER MTSK-63 MODULARE WERKZEUGAUFNAHMEN SIEHE SEITE TBL300-1-63

Cod. MT	Mandrino Spindle Spindel	I	RPM	Coppia Max Max Torque Max Drehmoment	Reversibile lato mandrino/contromandrino Reversible sub/main spindle side Umkehrbare Spindel-seite/ Gegenspindel-seite	Lubr.interna Coolant through Innenkuehlung	Lubr. esterna Ext. coolant Aussenkuehlung	B	CHIAVI NON INCLUDE Keys not included Schluessel nicht einbegriffen	
DW01600163	MTSK-63	1:1	3000	210Nm	X	-	X	75	CHUB68	NZL0010023 ■
DW01600263	MTSK-63	1:1	3000	210Nm	X	P=70bar	X	86	CHUB68	NZL0010023 ■

- Chiave inclusa
- Key included
- Schluessel inbegriffen

SAMSUNG
 MOD: SL60/65 MC - PL60/65/70/80 MC - SLV1000M

MODULO MOTORIZZATO ASSIALE MTSK H=110mm
 Axial MTSK driven tool H=110mm
 Axial MTSK angetriebenes Werkzeug H=110mm

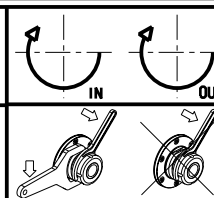

M.T. srl
 Via Casino Albini 480
 Tel. 0541/956034-957884
 Fax 0541/956341
 47842 S. GIOVANNI IN M. (RN)
 e-mail: mtma@mtmarchetti.com
 http://www.mtmarchetti.com

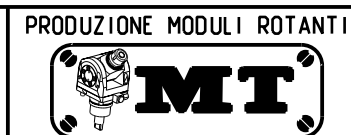

PAGINA SMG150-3-20-K

Subject to change without notice.

10/2018

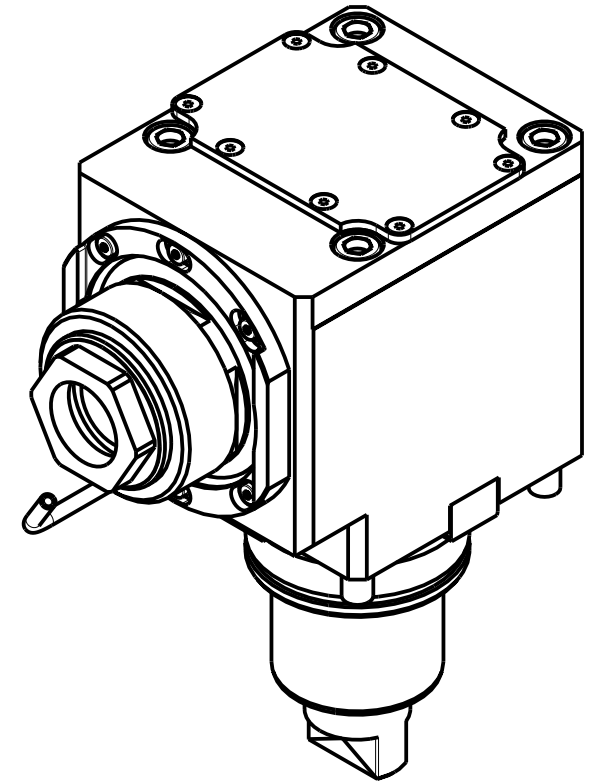
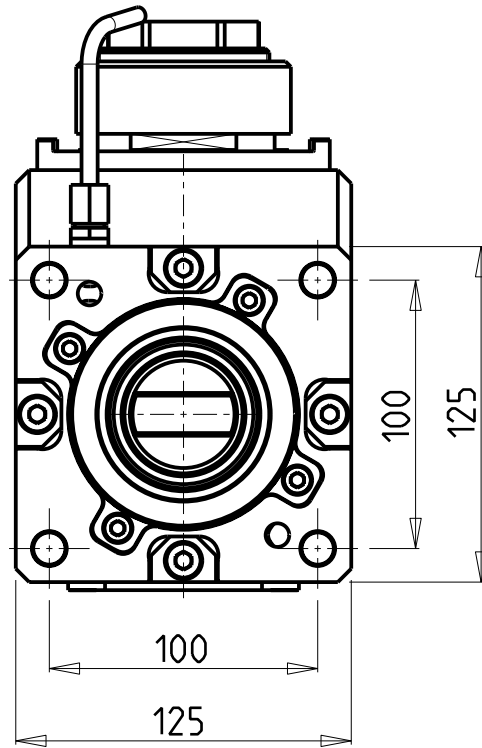
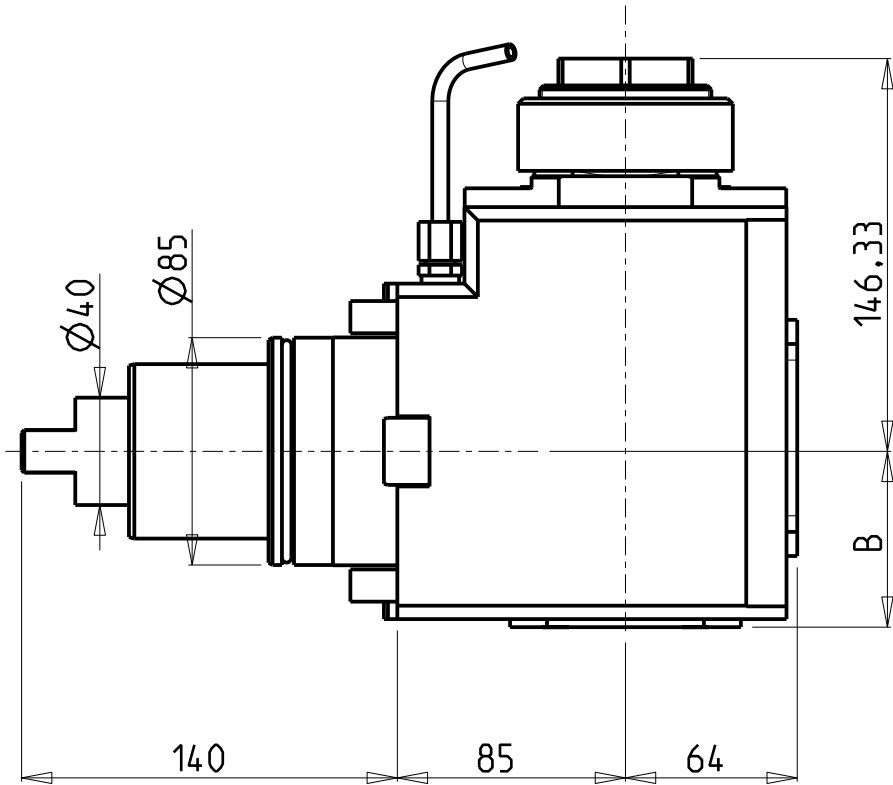

Cod. MT	Mandrino Spindle Spindel	I	RPM	Coppia Max Max Torque Max Drehmoment	Reversibile lato mandrino/contromandrino Reversible sub/main spindle side Umkehrbare Spindel-seite/ Gegenspindel-seite	Lubrificazione int. Coolant through Innenkuhlung	Lubrificazione est. Ext. coolant Aussenkuhlung	B	CHIAVI NON INCLUSE Keys not included Schlüssel nicht einbegriffen	
DW 00460150	ER A 50	2:1	1500	300Nm	X		X	65.5	CHUB50	NZL0010023 •
DW 00460250	ER A 50	2:1	1500	300Nm	X	P=70bar	X	82	CHUB50	NZL0010023 •

- Chiave inclusa
- Key included
- Schlüssel inbegriffen

SAMSUNG
MOD: SL60/65 MC - PL60/65/70/80 MC
 MODULO MOTORIZZATO ASSIALE RIDOTTO I=2:1 H=85mm
 Axial geared-down I=2:1 driven tool H=85mm
 Axial angetriebenes Werkzeug untersetzt I=2:1 H=85mm

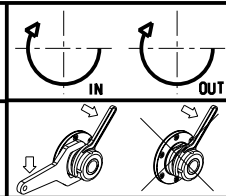

M.T. srl
 Via Casino Albini 480
 Tel. 0541/956034-957884
 Fax 0541/956341
 47842 S. GIOVANNI IN M. (RN)
 e-mail: mtma@mtmarchetti.com
 http://www.mtmarchetti.com

PRODUZIONE MODULI ROTANTI

 PAGINA SMG190-3-10

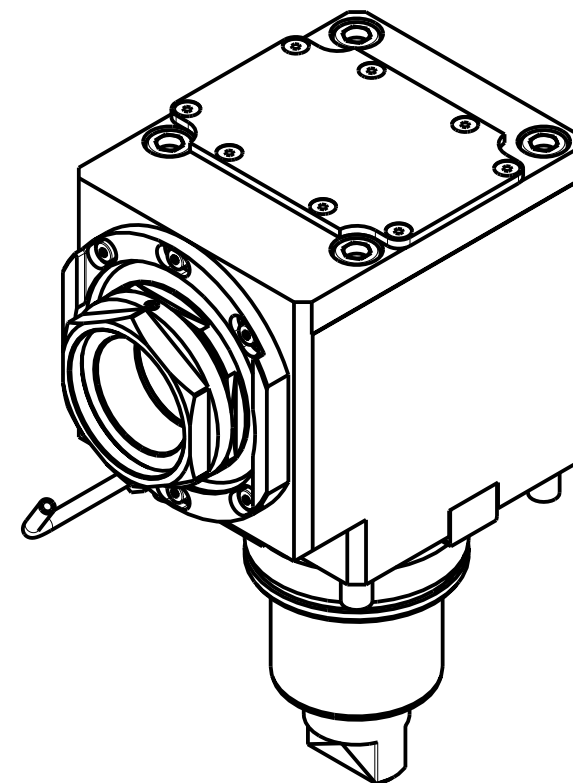
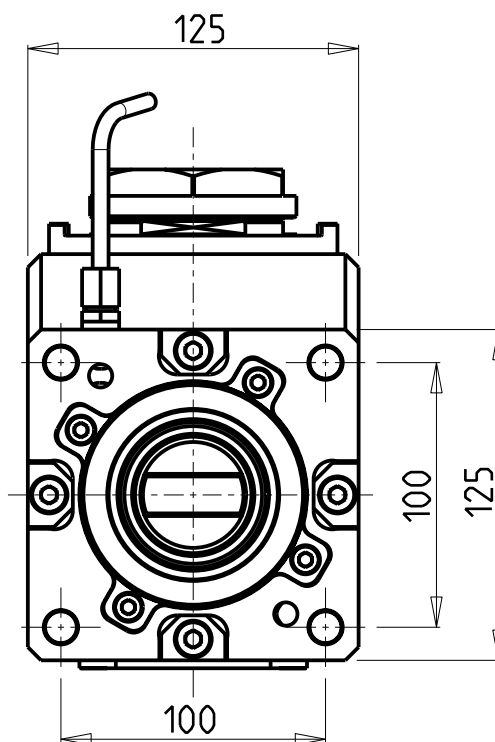
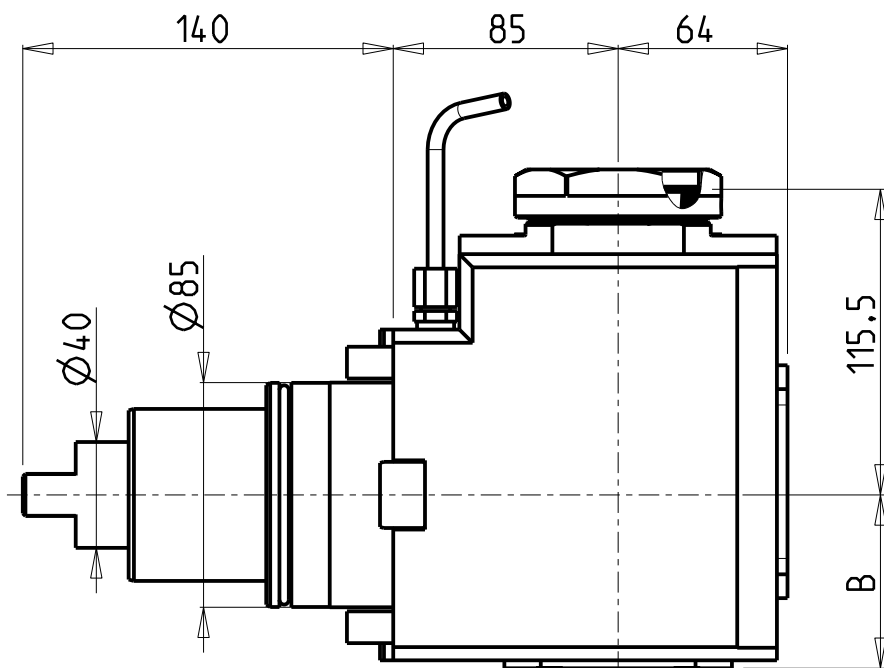
Subject to change without notice.



PER PORTAUTENSILI MODULARI MTSK-63 VEDI PAG. TBL300-1-63
 FOR MTSK-63 QUICK CHANGE TOOLHOLDERS CLAMPINGS SEE PAGE TBL300-1-63
 FUER MTSK-63 MODULARE WERKZEUGAUFNAHMEN SIEHE SEITE TBL300-1-63

Cod. MT	Mandrino Spindle Spindel	I	RPM	Coppia Max Max Torque Max Drehmoment	Reversibile lato mandrino/contromandrino Reversible sub/main spindle side Umkehrbare Spindelseite/Gegenspindelseite	Lubrificazione int. Coolant through Innenkuhlung	Lubrificazione est. Ext. coolant Aussenkuhlung	B	CHIAVI NON INCLUSE Keys not included Schlüssel nicht einbegriffen	
DW 00760163	MTSK-63	2:1	1500	300Nm	X		X	65.5	CHUB68	NZL0010023 •
DW 00760263	MTSK-63	2:1	1500	300Nm	X	P=70bar	X	82	CHUB68	NZL0010023 •

- Chiave inclusa
- Key included
- Schlüssel inbegriffen

SAMSUNG
 MOD: SL60/65 MC - PL60/65/70/80 MC

MODULO MOTORIZZATO ASSIALE MTSK RIDOTTO I=2:1 H=85mm
 Axial MTSK geared-down I=2:1 driven tool H=85mm
 Axial MTSK angetriebenes Werkzeug untersetzt I=2:1 H=85mm

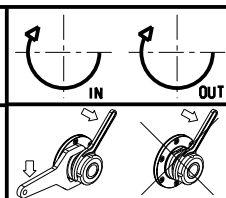

M.T. srl
 Via Casino Albini 480
 Tel. 0541/956034-957884
 Fax 0541/956341
 47842 S. GIOVANNI IN M. (RN)
 e-mail: mtma@mtmarchetti.com
 http://www.mtmarchetti.com

PRODUZIONE MODULI ROTANTI



PAGINA SMG190-3-10-K

Subject to change without notice.

10/2018

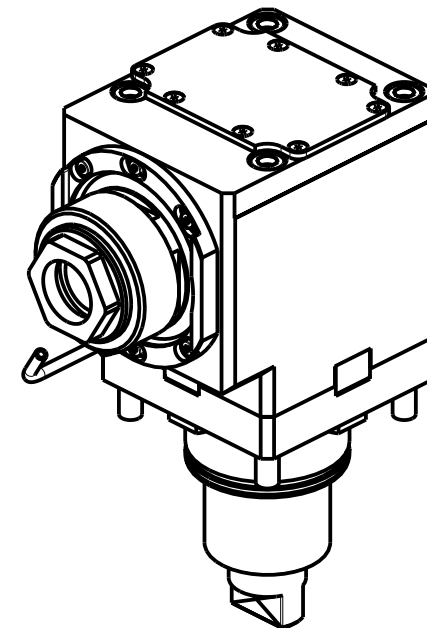
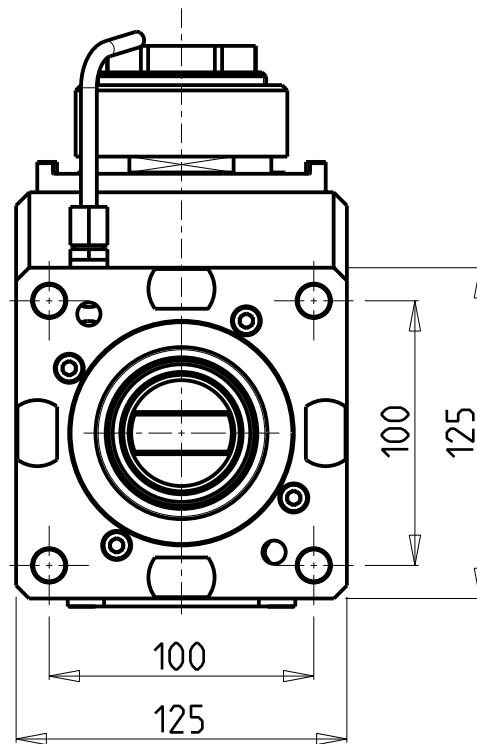
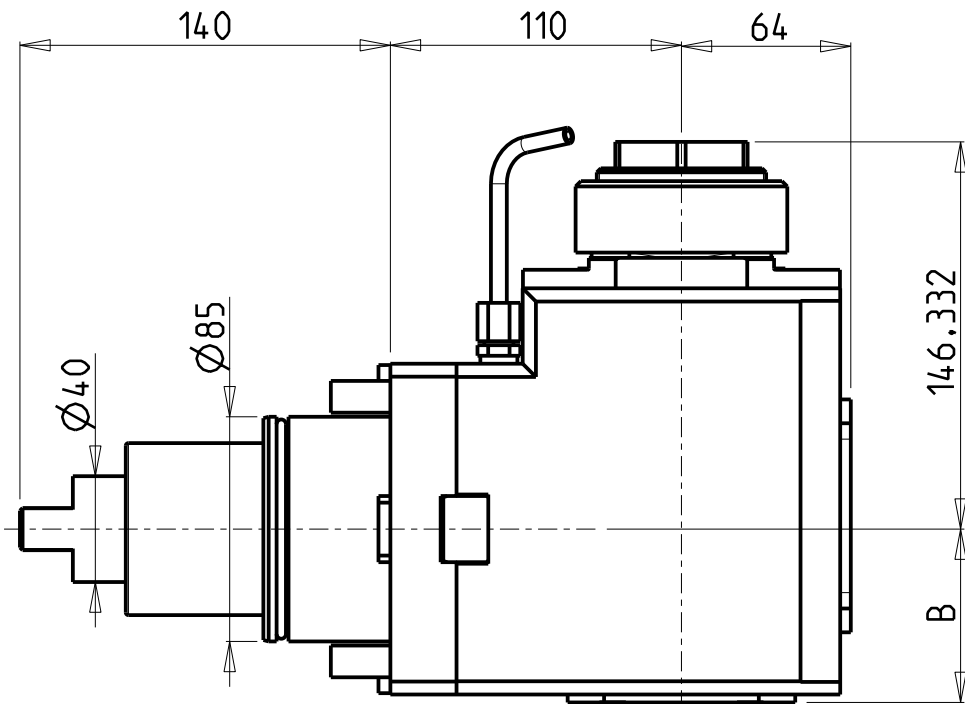

Cod. MT	Mandrino Spindle Spindel	I	RPM	Coppia Max Max Torque Max Drehmoment	Reversibile lato mandrino/contromandrino Reversible sub/main spindle side Umkehrbare Spindelseite/ Gegenspindelseite	Lubrificazione int. Coolant through Innenkuhlung	Lubrificazione est. Ext. coolant Aussenkuhlung	B	CHIAVI NON INCLUSE Keys not included Schlüssel nicht einbegriffen	
DW01210150	ER A 50	2:1	1500	300Nm	X		X	65.5	CHUB50	NZL0010023 •
DW01210250	ER A 50	2:1	1500	300Nm	X	P=70bar	X	82	CHUB50	NZL0010023 •

- Chiave inclusa
- Key included
- Schlüssel inbegriffen

SAMSUNG
 MOD: SL60/65 MC - PL60/65/70/80 MC - SLV1000M

MODULO MOTORIZZATO ASSIALE RIDOTTO I=2:1 H=110mm
 Axial geared-down I=2:1 driven tool H=110mm
 Axial angetriebenes Werkzeug untersetzt I=2:1 H=110mm

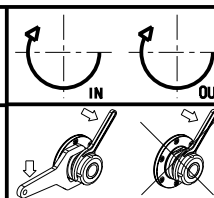

M.T. srl
 Via Casino Albini 480
 Tel. 0541/956034-957884
 Fax 0541/956341
 47842 S. GIOVANNI IN M. (RN)
 e-mail: mtma@mtmarchetti.com
 http://www.mtmarchetti.com

PRODUZIONE MODULI ROTANTI



PAGINA SMG190-3-20

Subject to change without notice.

10/2018

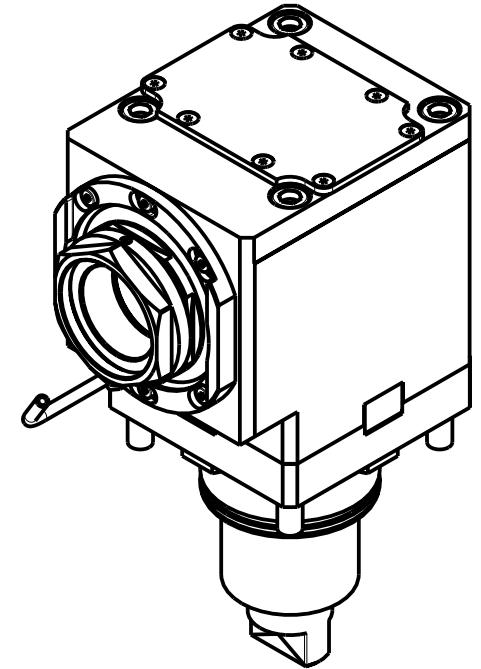
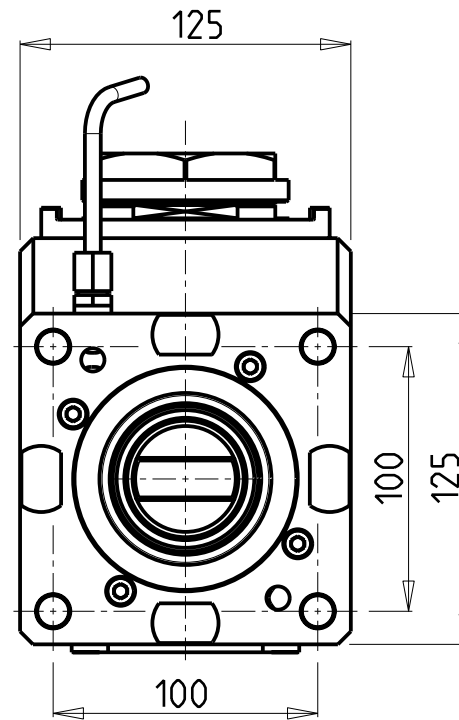
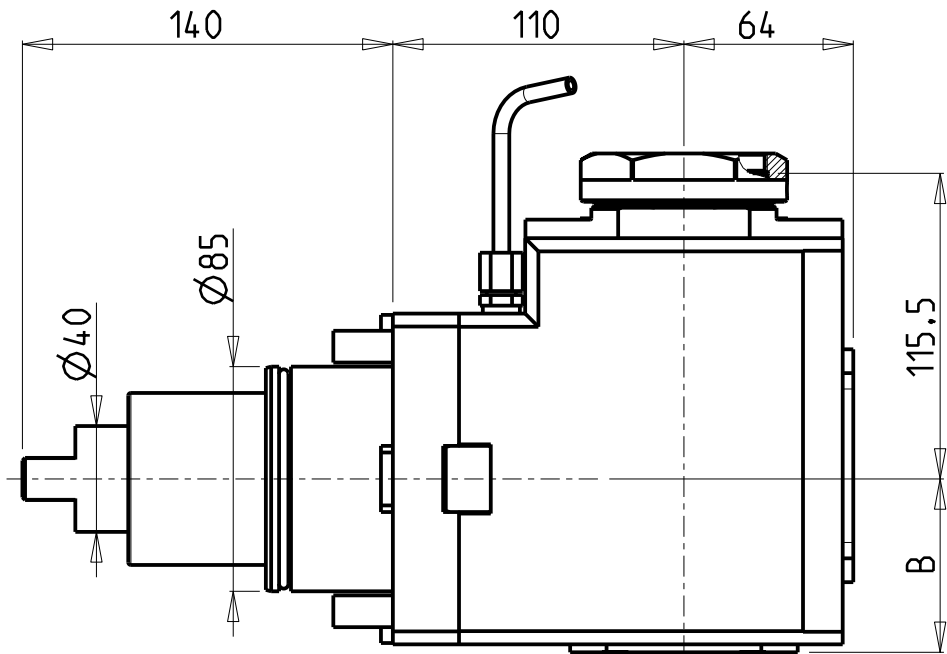

PER PORTAUTENSILI MODULARI MTSK-63 VEDI PAG. TBL300-1-63
 FOR MTSK-63 QUICK CHANGE TOOLHOLDERS CLAMPINGS SEE PAGE TBL300-1-63
 FUER MTSK-63 MODULARE WERKZEUGAUFNAHMEN SIEHE SEITE TBL300-1-63

Cod. MT	Mandrino Spindle Spindel	I	RPM	Coppia Max Max Torque Max Drehmoment	Reversibile lato mandrino/contromandrino Reversible sub/main spindle side Umkehrbare Spindel-seite/ Gegenspindel-seite	Lubrificazione int. Coolant through Innenkuhlung	Lubrificazione est. Ext. coolant Aussenkuhlung	B	CHIAVI NON INCLUSE Keys not included Schlüssel nicht einbegriffen	
DW01200163	MTSK-63	2:1	1500	300Nm	X		X	65.5	CHUB68	NZL0010023 •
DW01200263	MTSK-63	2:1	1500	300Nm	X	P=70bar	X	82	CHUB68	NZL0010023 •

- Chiave inclusa
- Key included
- Schlüssel inbegriffen

SAMSUNG
 MOD: SL60/65 MC - PL60/65/70/80 MC - SLV1000M

MODULO MOTORIZZATO ASSIALE MTSK RIDOTTO I=2:1 H=110mm
 Axial MTSK geared-down I=2:1 driven tool H=110mm
 Axial MTSK angetriebenes Werkzeug untersetzt I=2:1 H=110mm

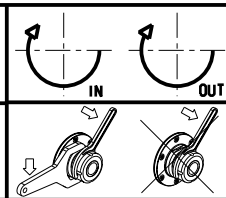

M.T. srl
 Via Casino Albini 480
 Tel. 0541/956034-957884
 Fax 0541/956341
 47842 S. GIOVANNI IN M. (RN)
 e-mail: mtma@mtmarchetti.com
 http://www.mtmarchetti.com

PRODUZIONE MODULI ROTANTI

 PAGINA SMG190-3-20-K

Subject to change without notice.

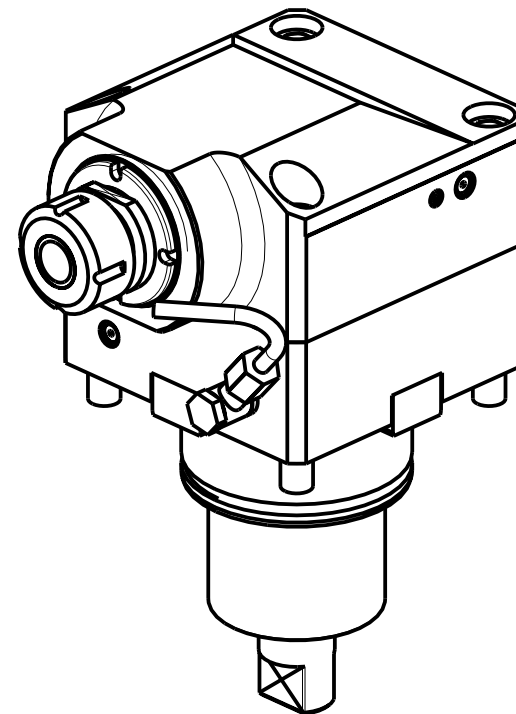
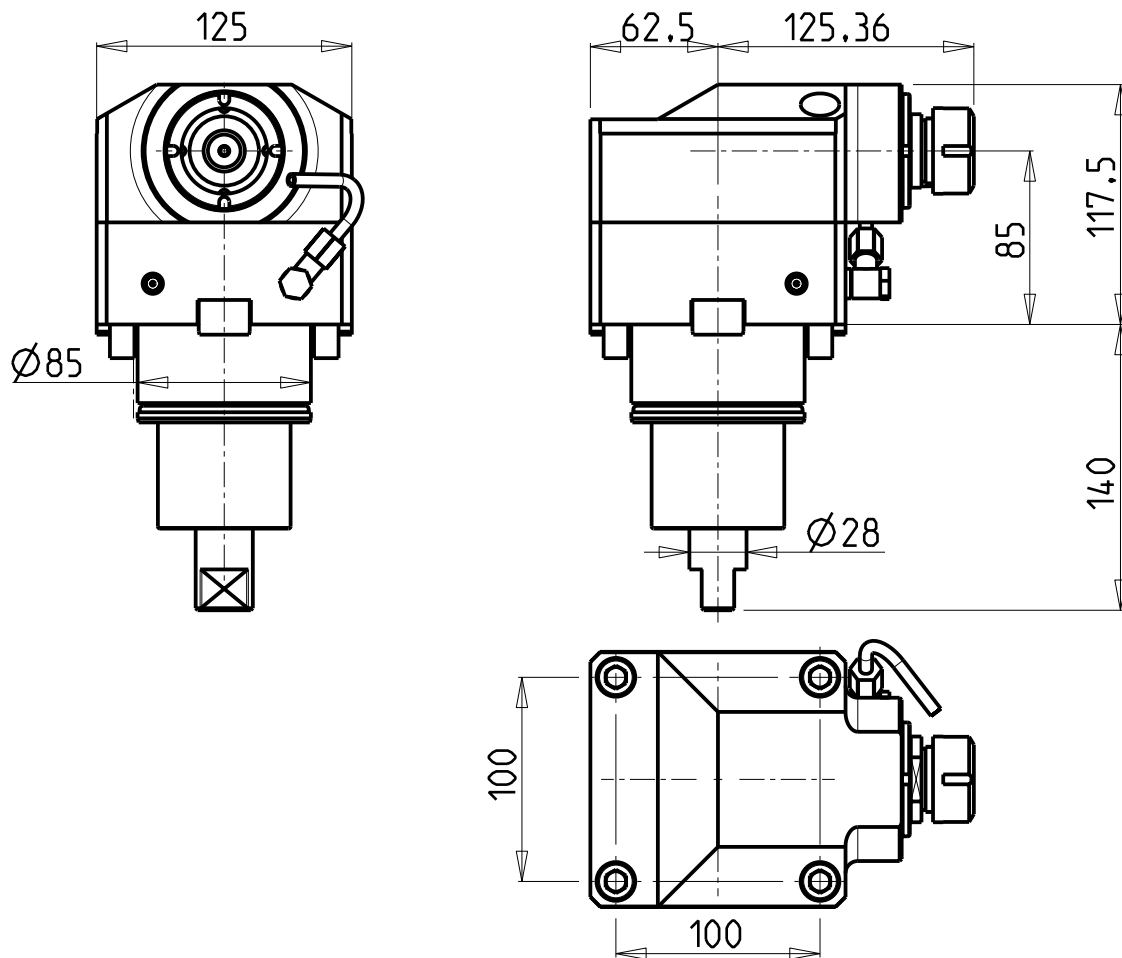
10/2018



Cod. MT	Mandrino Spindle Spindel	i	RPM MAX	Coppia Max Max Torque Max Drehmoment	Lubrificazione int. Coolant through Innenkuehlung	Lubrificazione est. Ext. coolant Aussenkuehlung	CHIAVI NON INCLUDE Keys not included Schluessel nicht einbegriffen	
							CHSTER25	CHUB36
DW 00580125	ER25	1:3	9000	70Nm		X	CHSTER25	CHUB36
DW 00580225	ER25	1:3	9000	70Nm	P=70bar	X	CHSTER25	CHUB36

SAMSUNG

MOD: SL60/65 MC - PL60/65/70/80 MC

MODULO MOTORIZZATO ASSIALE MOLTIPLICATO I=1:3

Axial geared-up I=1:3 driven tool

Axial angetriebenes Werkzeug uebersetzt I=1:3

Subject to change without notice.

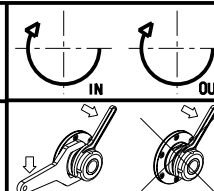

M.T. srl

Via Casino Albini 480
Tel. 0541/956034-957884
Fax 0541/956341
47842 S. GIOVANNI IN M. (RN)
e-mail: mtma@mtmarchetti.com
http://www.mtmarchetti.com

PRODUZIONE MODULI ROTANTI



PAGINA SMG205-3-10

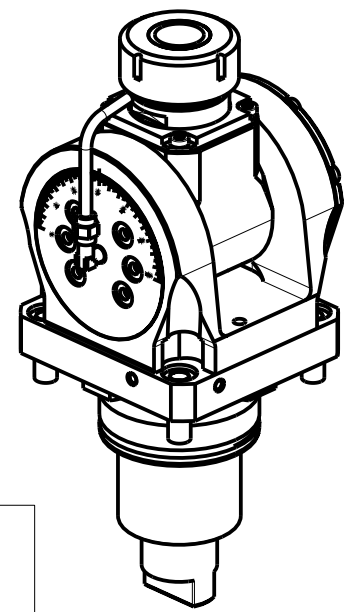
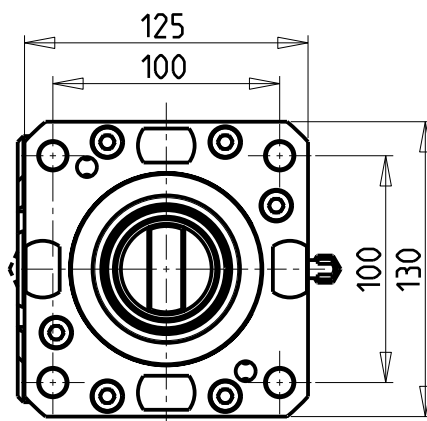
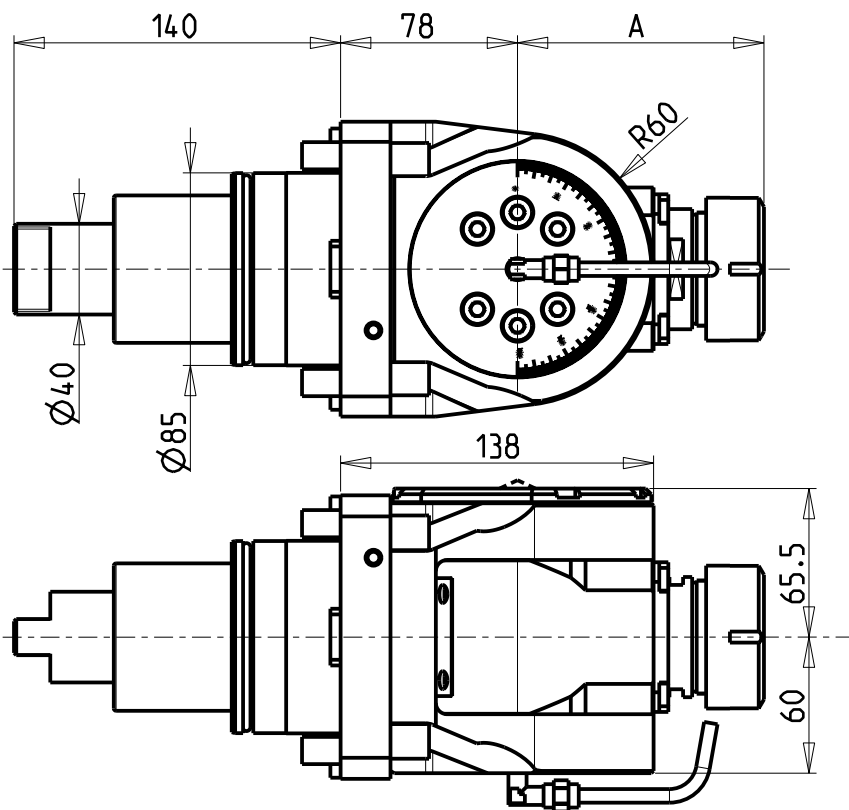

Cod. MT	Mandrino Spindle Spindel	I	RPM	Coppia Max Max Torque Max Drehmoment	Lubrificazione int. Coolant through Innenkuehlung	Lubrificazione est. Ext. coolant Aussenkuehlung	A	CHIAVI INCLUSE Keys included Schluessel inbegriffen				
								CHUB30	CHUB46	CHTAER32ZC	CHESL10	CHESL06
DW00830332	ERA32	1:1	3000	50Nm		X	81	CHUB30	CHUB46	CHTAER32ZC	CHESL10	CHESL06
DW00830432	ERA32	1:1	3000	50Nm	P=70bar	X	81	CHUB30	CHUB46	CHTAER32ZC	CHESL10	CHESL06
DW00830140	ER40	1:1	3000	50Nm		X	108.66	-	CHUB46	CHSTER40	CHESL10	CHESL06
DW00830240	ER40	1:1	3000	50Nm	P=70bar	X	108.66	-	CHUB46	CHSTER40	CHESL10	CHESL06

SAMSUNG
 MOD: SL60/65 MC - PL60/65/70/80 MC - SLV1000M

MODULO MOTORIZZATO ORIENTABILE +/-90°
 +/-90° adjustable angle driven tool
 Angetriebenes Werkzeug schwenkbar +/-90°

Subject to change without notice.

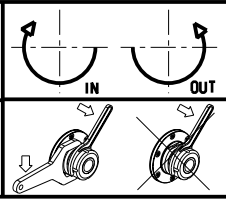

M.T. srl
 Via Casino Albini 480
 Tel. 0541/956034-957884
 Fax 0541/956341
 47842 S. GIOVANNI IN M. (RN)
 e-mail: mtma@mtmarchetti.com
 http://www.mtmarchetti.com

PRODUZIONE MODULI ROTANTI

PAGINA SMG339-3-00

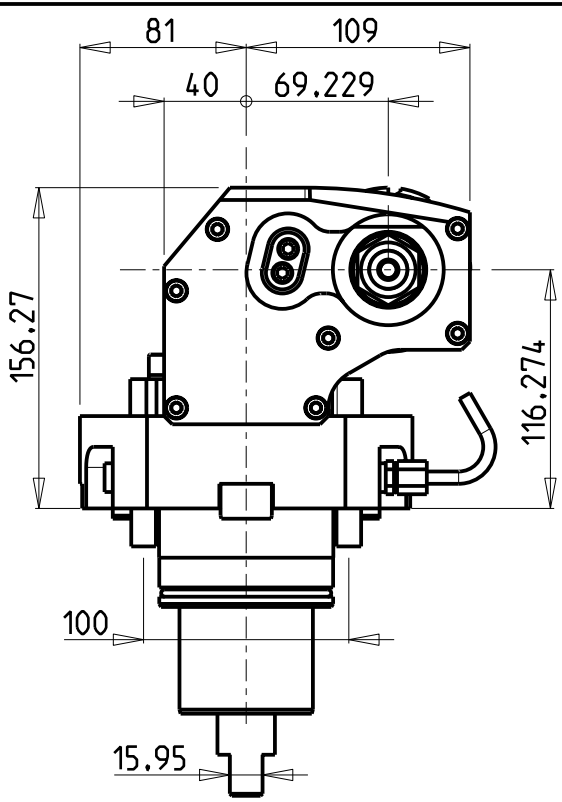
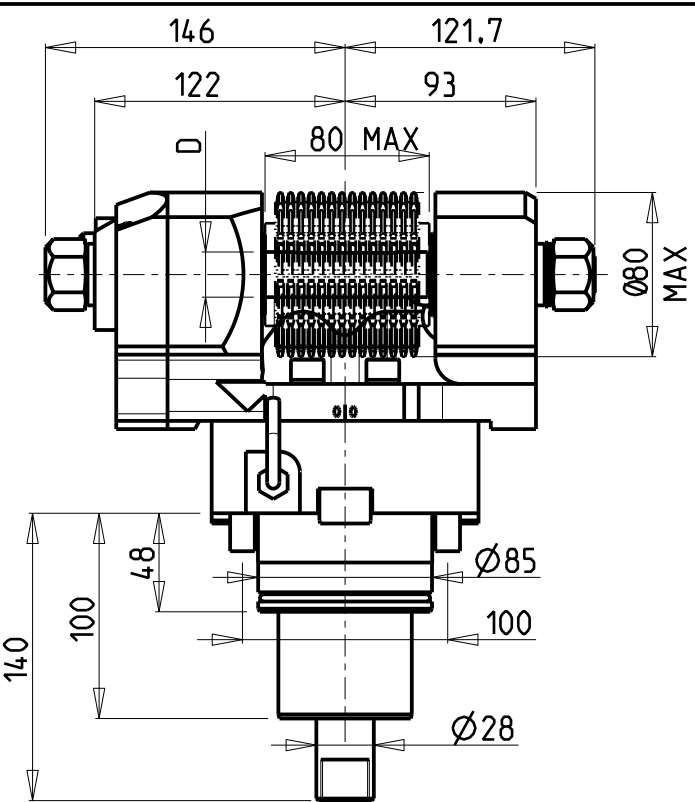

INCLINAZIONE
REGOLABILE $\pm 30^\circ$

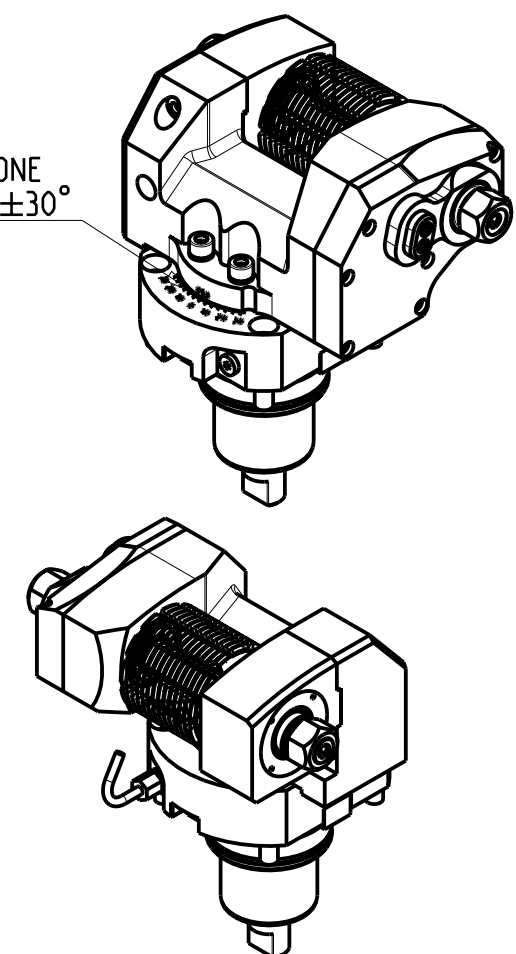

DOTAZIONI - SUPPLIED WITH - AUSSTATTUNG

- N°1 ALBERO + DISTANZIALI
- N°1 SHAFT + SPACER
- N°1 DORN + ABSTANDSSTUECK

PER ALBERI E DISTANZIALI VEDI PAG. TBL250-1-00
FOR SHAFT END SPACER SEE PAGE TBL250-1-00
FUER DORN UND ABSTANDSSTUECK SEITE TBL250-1-00

Cod. MT	I	RPM MAX	Coppia Max Max Torque Max Drehmoment	Lubrificazione est. Ext. coolant Aussenkuehlung	D (mm)	D (Inch)	CHIAVI INCLUSE Keys included Schlüssel inbegriffen			
							CHUB30	CHESL08	CHESL10	CHUB24 (Ø16 / Ø3/4")
DW00181100	1:1	3000	90Nm	X	16-22-27-32	3/4"-1"-1 1/4"	CHUB30	CHESL08	CHESL10	CHUB24 (Ø16 / Ø3/4")
DW00182100	2:1	1500	110Nm	X	16-22-27-32	3/4"-1"-1 1/4"	CHUB30	CHESL08	CHESL10	CHUB24 (Ø16 / Ø3/4")

SAMSUNG
MOD: SL60/65 MC - PL60/65/70/80 MC - SLV1000M

MODULO MOTORIZZATO PORTACREATORE MAGGIORATO
Reinforced driven gear hobber
Angetriebenes Zahnradwaeltzraes-Werkzeug vergroessert

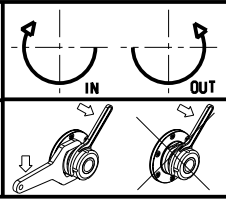

M.T. srl
Via Casino Albini 480
Tel. 0541/956034-957884
Fax 0541/956341
47842 S. GIOVANNI IN M. (RN)
e-mail: mtma@mtmarchetti.com
http://www.mtmarchetti.com

PRODUZIONE MODULI ROTANTI



PAGINA SMG340-3-60

Subject to change without notice.

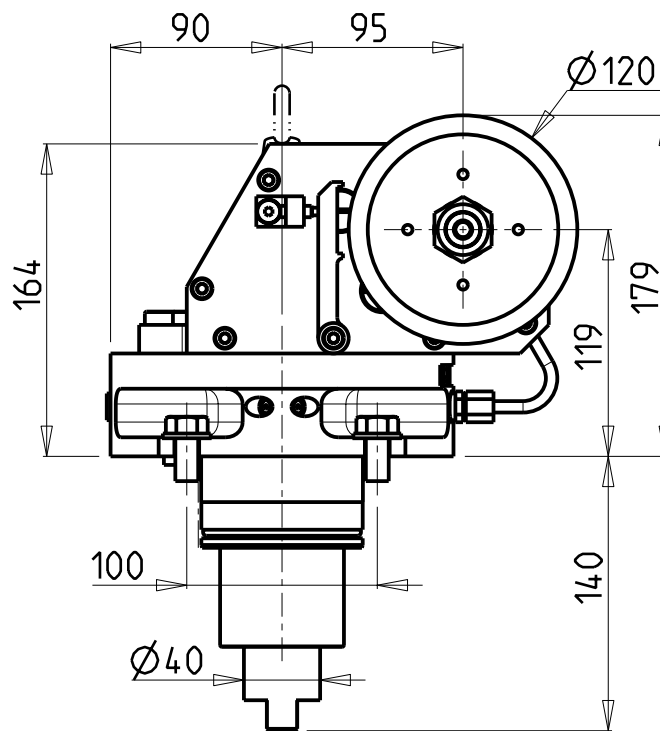
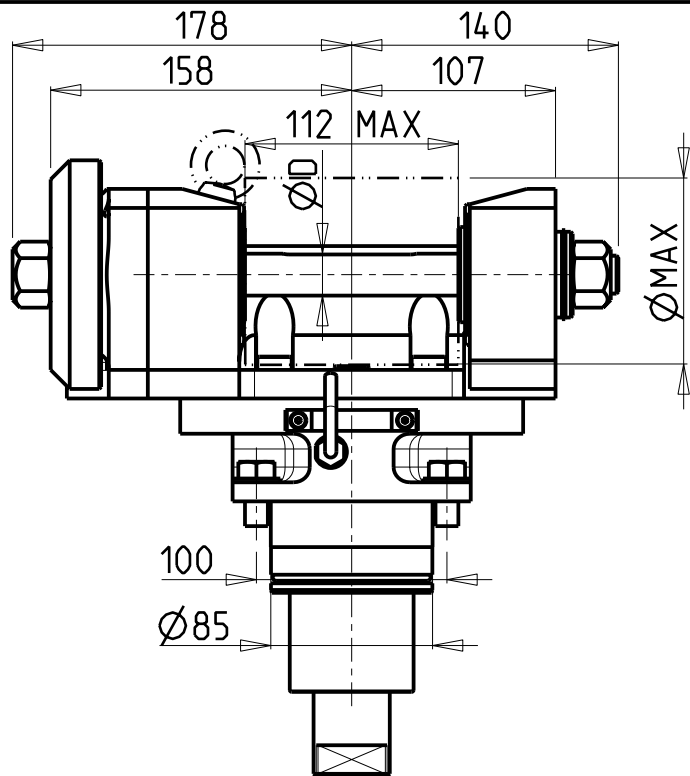

D (mm)	ØMAX (mm)
22	89
27-32	100

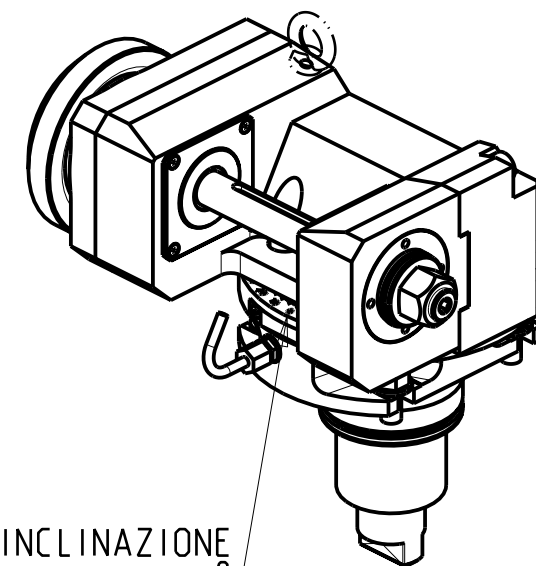

INCLINAZIONE
REGOLABILE ±180°

DOTAZIONI - SUPPLIED WITH - AUSSTATTUNG

- | mm / inch | |
|-----------|-----------------------------|
| | - N°1 ALBERO + DISTANZIALI |
| | - N°1 SHAFT + SPACER |
| | - N°1 DORN + ABSTANDSSTUECK |

PER ALBERI E DISTANZIALI VEDI PAG. TBL250-1-00
FOR SHAFT END SPACER SEE PAGE TBL250-1-00
FUER DORN UND ABSTANDSSTUECK SEITE TBL250-1-00

Cod. MT	i	RPM max	Coppia Max Max Torque Max Drehmoment	Lubrificazione est. Ext. coolant Aussenkuehlung	D (mm)	CHIAVI INCLUSE Keys included Schluessel inbegriffen			
						CHUB30	CHESL08	CHESL10	CHUB19
DW 00851100	1:1	3000	110Nm	X	22-27-32	CHUB30	CHESL08	CHESL10	CHUB19
DW 00852100	2:1	1500	130Nm	X	22-27-32	CHUB30	CHESL08	CHESL10	CHUB19

SAMSUNG

MOD: SL60/65 MC - PL60/65/70/80 MC - SLV1000M

MODULO MOTORIZZATO PORTACREATORE (TAGLIA GRANDE)

Driven gear hobber (big size)

Angetriebenes Zahnradwaelzfraes-Werkzeug (grosse version)

Subject to change without notice.

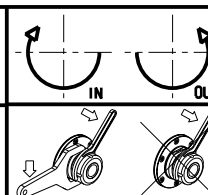

M.T. srl

Via Casino Albini 480
Tel. 0541/956034-957884
Fax 0541/956341
47842 S. GIOVANNI IN M. (RN)
e-mail: mtma@mtmarchetti.com
http://www.mtmarchetti.com

PRODUZIONE MODULI ROTANTI



PAGINA SMG340-3-80

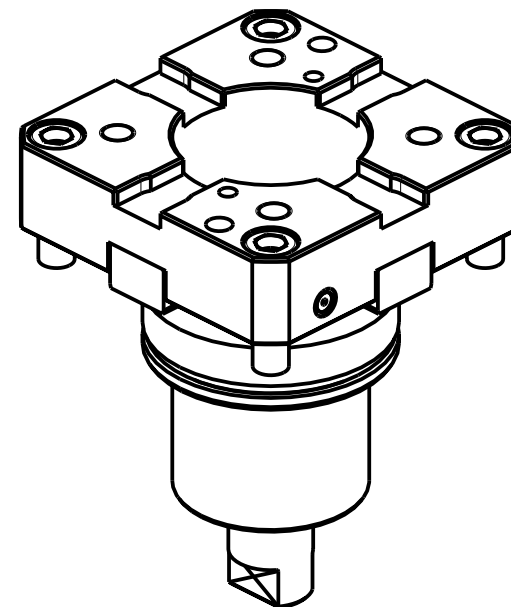
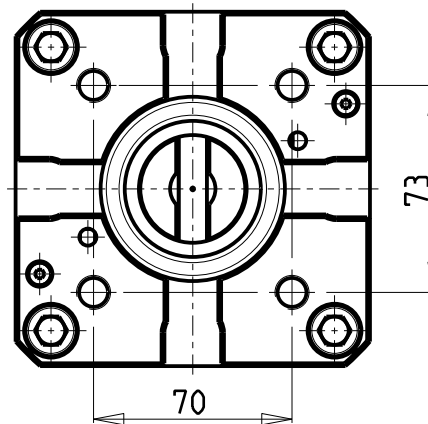
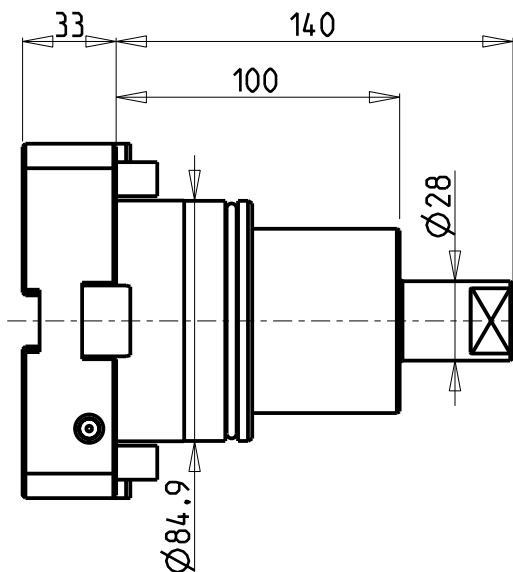
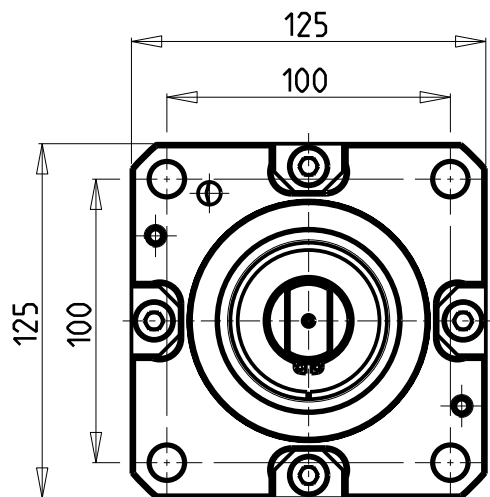

ATTENZIONE - ATTENTION - ACHTUNG

-PERICOLO COLLISIONE PEZZO FUORI VOLTEGGIO

-Danger of collision! Tooling out of interference

-Kollisionsgefahr! Werkzeug ausser Interferenz

Cod. MT

DW00370100

SAMSUNG

MOD: SL60/65 MC - PL60/65/70/80 MC - SLV1000M

INTERFACCIA PER MODULI BMT-65 H=33mm

BMT-65 tooling adapter cartridge H=33mm

Adapter-Patrone fuer BMT-65 werkzeuge H=33mm

Subject to change without notice.

M.T. srl

Via Casino Albini 480
Tel. 0541/956034-957884

Fax 0541/956341

47842 S. GIOVANNI IN M. (RN)
e-mail: mtma@mtmarchetti.com
http://www.mtmarchetti.com

PRODUZIONE MODULI ROTANTI



PAGINA SMG385-3-00

10/2018

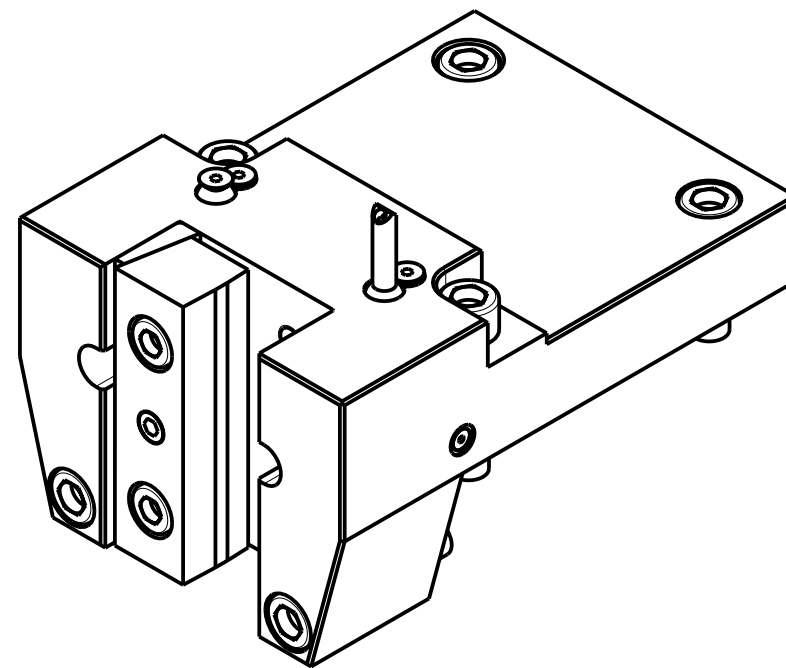
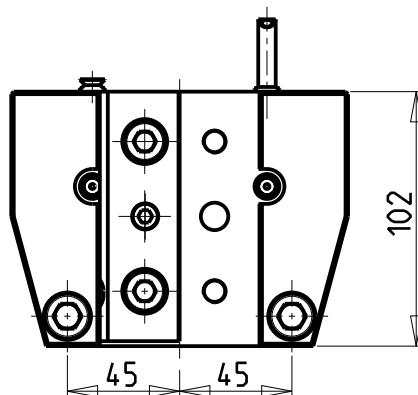
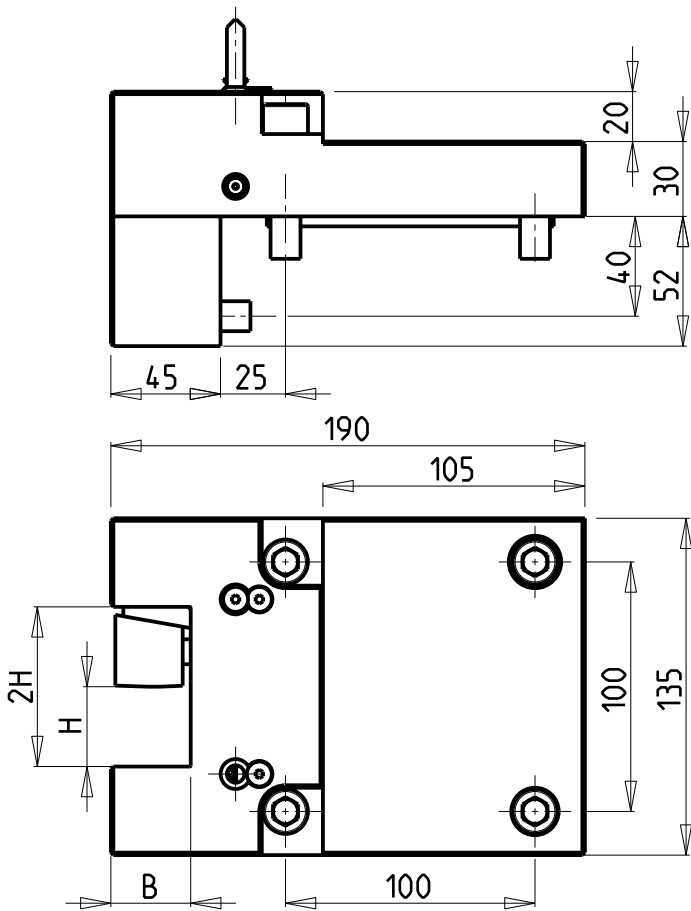

Cod. MT	N°Utensili N°Tools N°Werkzeuge	Lubrificazione est. Ext. coolant Aussehenkuehlung	Misure Dimensions Masse	B	H
DW01073200	1	X	mm	32	32
DW01073175	1	X	Inch	1-1/4"	1-1/4"

SAMSUNG
MOD: SL60/65 MC - PL60/65/70/80 MC
PORTAUTENSILE RADIALE SINGOLO QD=32mm / QD=1 1/4"
Radial single static tool QD=32mm / QD=1 1/4"
Radial Single-Werkzeughalter QD=32mm / QD=1 1/4"

Subject to change without notice.

M.T. srl
 Via Casino Albini 480
 Tel. 0541/956034-957884
 Fax 0541/956341
 47842 S. GIOVANNI IN M. (RN)
 e-mail: mtma@mtmarchetti.com
 http://www.mtmarchetti.com

PRODUZIONE MODULI ROTANTI



PAGINA SMG423-3-00

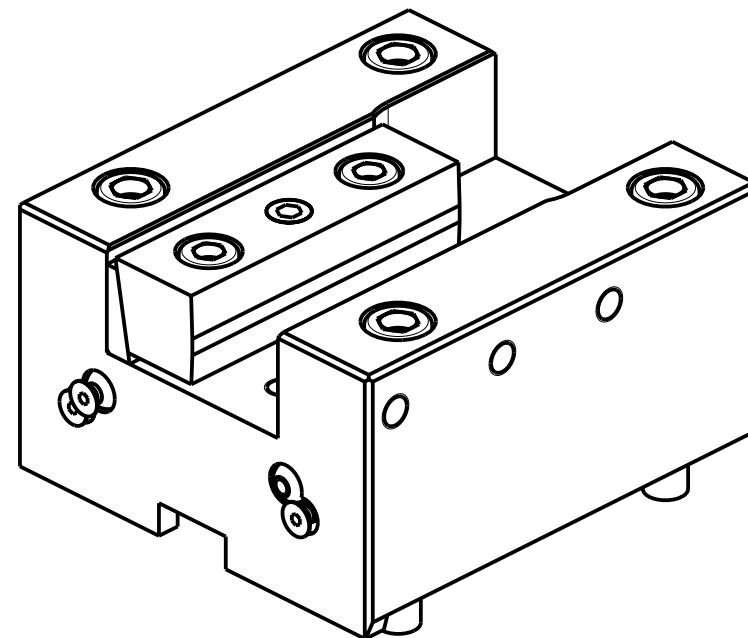
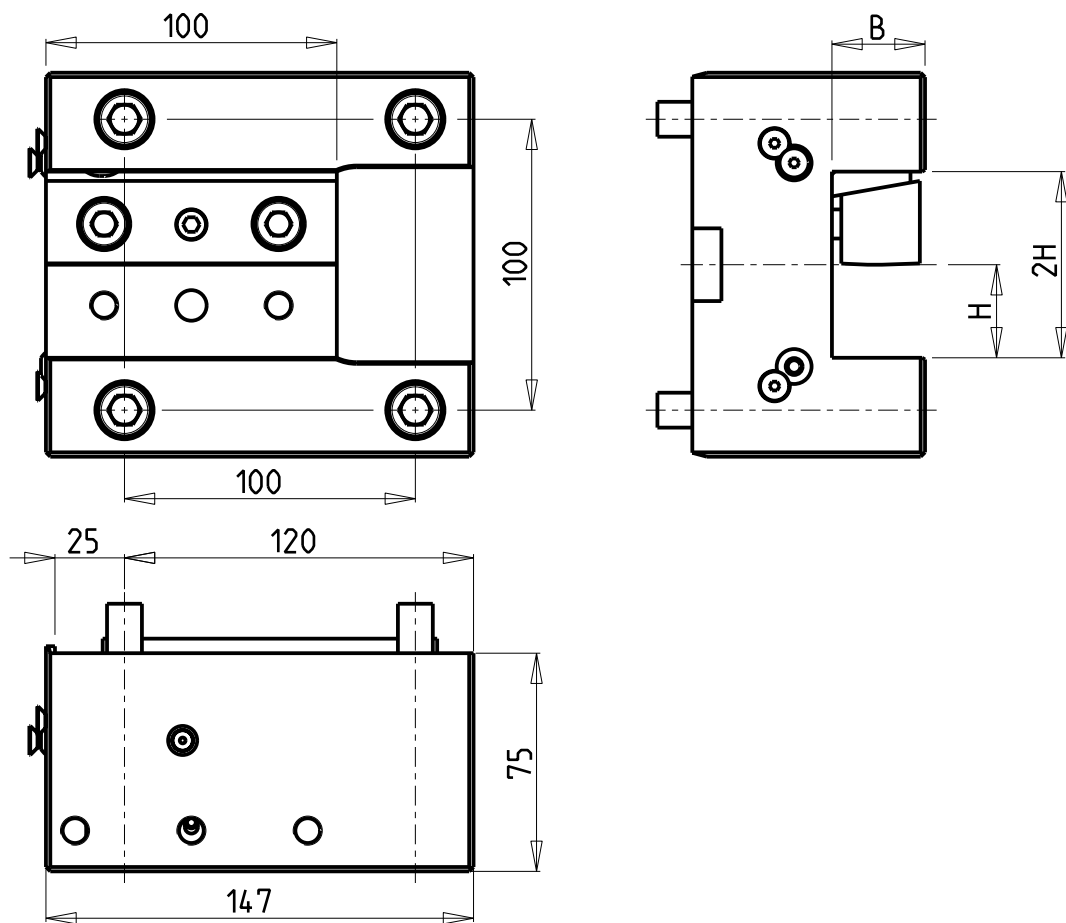

Cod. MT	N°Utensili N°Tools N°Werkzeuge	Reversibile lato mandrino/contromandrino Reversible sub/main spindle side Umkehrbare Spindel-seite/ Gegenspindel-seite	Lubrificazione est. Ext. coolant Aussehenkuehlung	Misure Dimensions Masse	B	H
DW 01053200	1/2	X	X	mm	32	32
DW 01053175	1/2	X	X	Inch	1-1/4"	1-1/4"

SAMSUNG

MOD: SL60/65 MC - PL60/65/70/80 MC

PORTAUTENSILE ASSIALE SINGOLO QD=32mm / QD=1 1/4"

Axial single static tool QD=32mm / QD=1 1/4"

Axial Single-Werkzeughalter QD=32mm / QD=1 1/4"

Subject to change without notice.

M.T. srl

Via Casino Albini 480
Tel. 0541/956034-957884
Fax 0541/956341

47842 S. GIOVANNI IN M. (RN)
e-mail: mtma@mtmarchetti.com
<http://www.mtmarchetti.com>

PRODUZIONE MODULI ROTANTI



PAGINA SMG552-3-00

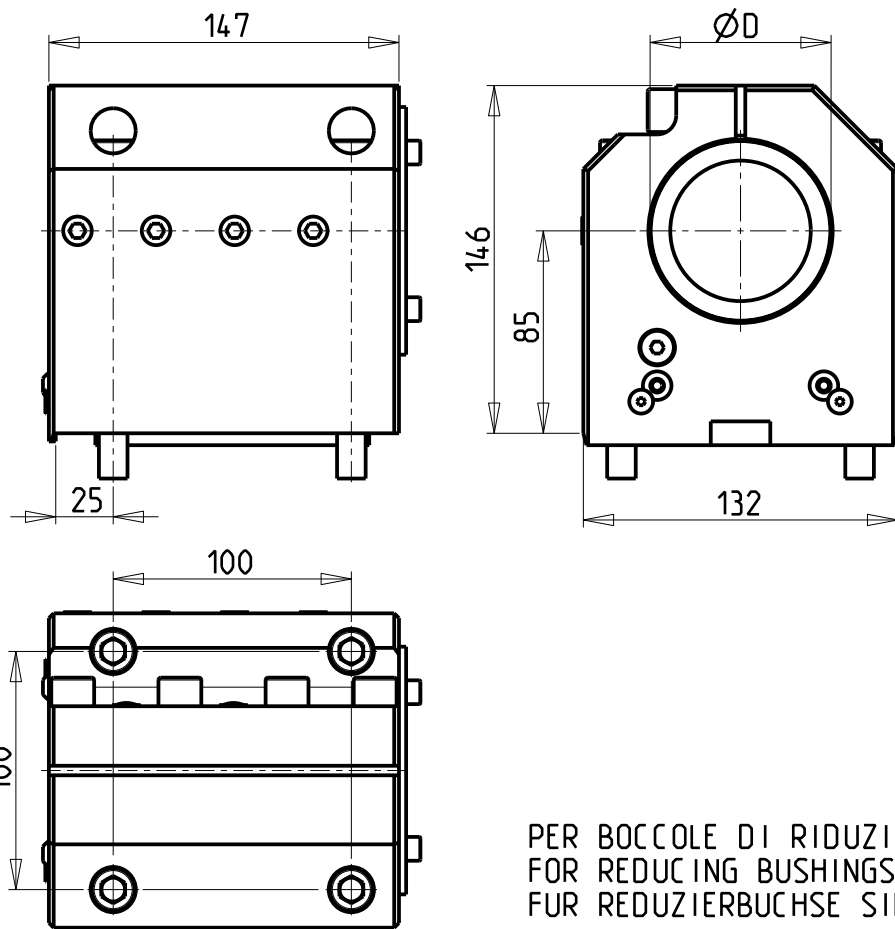

KIT ADDUZIONE INTERNA (OPZIONALE)
 KIT FOR INTERNAL COOLANT (OPTIONAL)
 KIT FUER INTERNE KUEHLMITTELZUFUHR (OPTIONAL)
 Ø80 cod. KIT1002013
 Ø3" cod. KIT1002014

SOLO GUARNIZIONE (OPZIONALE)
 ONLY SEAL (OPTIONAL)
 NUR DICHTUNG (OPTIONAL)
 cod. MNL0310005

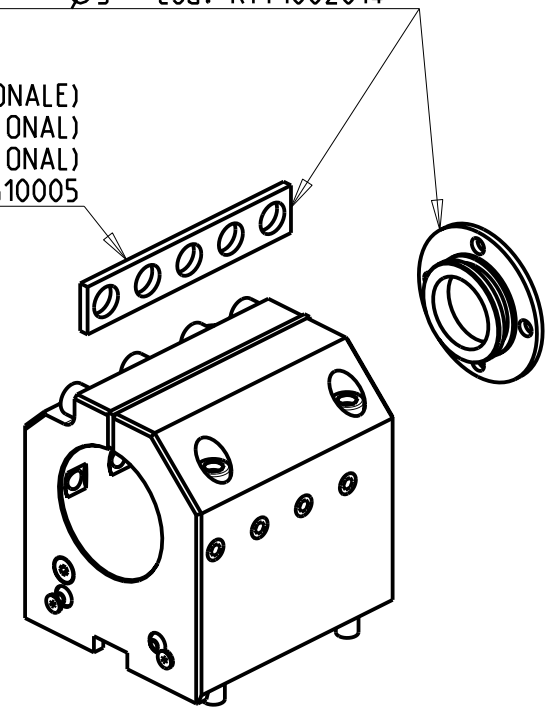

PER BOCCOLE DI RIDUZIONE VEDI PAG. TBL150-1-00
 FOR REDUCING BUSHINGS SEE PAGE TBL150-1-00
 FÜR REDUZIERBUCHSE SIEHE SEITE TBL150-1-00

Cod. MT	N°Utensili N°Tools N°Werkzeuge	Reversibile lato mandrino/contromandrino Reversible sub/main spindle side Umkehrbare Spindel-seite/ Gegenspindel-seite	Lubrificazione int. opzionale Coolant through optional Innenkuehlung Optional	Lubrificazione est. Ext. coolant Aussenkuehlung	Misure Dimensions Masse	D
DW01068000	1	X	X	X	mm	80
DW01067620	1	X	X	X	Inch	3"

SAMSUNG

MOD: SL60/65 MC - PL60/65/70/80 MC

PORTAUTENSILE ASSIALE PER BARENO Ø80mm / Ø3" H=85mm

Axial single boring bar holder Ø80mm / Ø3" H=85mm

Axial Bohrhälter Ø80mm / Ø3" H=85mm

Subject to change without notice.

M.T. srl

Via Casino Albini 480
 Tel. 0541/956034-957884
 Fax 0541/956341
 47842 S. GIOVANNI IN M. (RN)
 e-mail: mtma@mtmarchetti.com
 http://www.mtmarchetti.com

PRODUZIONE MODULI ROTANTI



PAGINA SMG580-3-20