

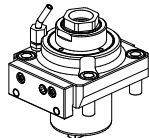

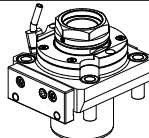

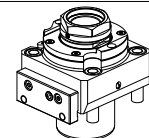
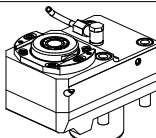
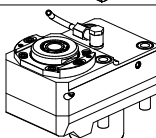
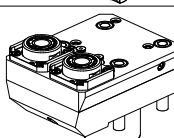
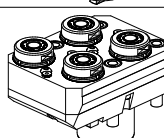
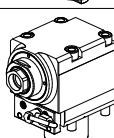
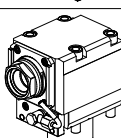
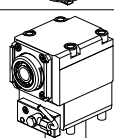
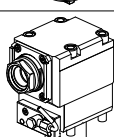

		PAGINA Page Seite
MODULO MOTORIZZATO RADIALE Radial driven tool Radial angetriebenes Werkzeug		OKU010.4.00
MODULO MOTORIZZATO RADIALE MTSK Radial MTSK driven tool Radial MTSK angetriebenes Werkzeug		OKU010.4.00.K
MODULO MOTORIZZATO RADIALE MTSK ALTA PRESSIONE Radial MTSK driven tool high pressure Radial MTSK angetriebenes Werkzeug hochdruck		OKU010.4.20.K
MODULO MOTORIZZATO RADIALE DISASSATO IN Z 65mm Radial driven tool re-directed in Z by 65mm Radial angetriebenes Werkzeug achsversetzt in Z um 65mm		OKU030.4.10
MODULO MOTORIZZATO RADIALE RIDOTTO I=2:1 DISASSATO IN Z 65mm Radial geared-down I=2:1 driven tool re-directed in Z by 65mm Radial angetriebenes Werkzeug untersetzt I=2:1 achsversetzt in Z um 65mm		OKU030.4.20
MODULO MOTOR. RADIALE MOLTIPLICATO I=1:2 DISASSATO IN Z 65mm Radial geared-up I=1:2 driven tool re-directed in Z by 65mm Radial angetriebenes Werkzeug uebersetzt I=1:2 achsversetzt in Z um 65mm		OKU030.4.30
MODULO MOTORIZZATO RADIALE 2 USCITE SOVRAPPOSTE Radial single side twin head driven tool Radial angetriebenes Werkzeug 2 Ausgaenge ueberlagert		OKU090.4.00
MODULO MOTORIZZATO RADIALE 4 USCITE Radial 4 head driven tool Radial angetriebenes Werkzeug 4 Ausgaenge		OKU100.4.00
MODULO MOTORIZZATO ASSIALE H=70mm Axial driven tool H=70mm Axial angetriebenes Werkzeug H=70mm		OKU150.4.10
MODULO MOTORIZZATO ASSIALE MTSK H=70mm Axial MTSK driven tool H=70mm Axial MTSK angetriebenes Werkzeug H=70mm		OKU150.4.10.K
MODULO MOTORIZZATO ASSIALE H=90mm Axial driven tool H=90mm Axial angetriebenes Werkzeug H=90mm		OKU150.4.20 
MODULO MOTORIZZATO ASSIALE MTSK H=90mm Axial MTSK driven tool H=90mm Axial MTSK angetriebenes Werkzeug H=90mm		OKU150.4.20.K 

		PAGINA Page Seite
<p>MODULO MOTORIZZATO ASSIALE ARRETRATO Axial rear-set driven tool Axial angetriebenes Werkzeug zurueckversetzt</p>		OKU180.4.10
<p>MODULO MOTORIZZATO ASSIALE RIDOTTO I=2:1 Axial geared-down I=2:1 driven tool Axial angetriebenes Werkzeug untersetzt I=2:1</p>		OKU190.4.10
<p>MODULO MOTORIZZATO ASSIALE MOLTIPLICATO I=1:2 Axial geared-up I=1:2 driven tool Axial angetriebenes Werkzeug uebersetzt I=1:2</p>		OKU200.4.10
<p>MODULO MOTORIZZATO ASSIALE MOLTIPLICATO I=1:3 Axial geared-up I=1:3 driven tool Axial angetriebenes Werkzeug uebersetzt I=1:3</p>		OKU205.4.10
<p>MODULO MOTORIZZATO ASSIALE BISPORGENTE H=70mm Axial opposite face twin driven tool H=70mm Axial angetriebenes Werkzeug halb vorspringend H=70mm</p>		OKU240.4.10
<p>MODULO MOTORIZZATO ASSIALE BISPORGENTE H=90mm Axial opposite face twin driven tool H=90mm Axial angetriebenes Werkzeug halb vorspringend H=90mm</p>		OKU240.4.20 
<p>MODULO MOTORIZZATO ASSIALE 2/4 USCITE IN Y Axial multiple 2/4 outlet driven tool in Y Axial angetriebenes Mehrspindel-Werkzeug 2/4 Ausgaenge in Y</p>		OKU268.4.00
<p>MODULO MOTORIZZATO ORIENTABILE +/-90° +/-90° adjustable angle driven tool Angetriebenes Werkzeug schwenkbar +/-90°</p>		OKU335.4.00
<p>MODULO MOTORIZZATO ORIENTABILE ±90° CON NONIO DIGITALE ±90° adjustable angle driven tool with digital display Angetriebenes Werkzeug schwenkbar ±90° mit digital display</p>		OKU335.4.01
<p>MODULO MOTORIZZATO ORIENTABILE +/-90° MOLTIPLICATO I=1:2 +/-90° adjustable angle driven tool geared-up I=1:2 Angetriebenes Werkzeug schwenkbar +/-90° uebersetzt I=1:2</p>		OKU336.4.00
<p>MODULO MOTOR. ORIENTABILE ±90° MOLTIPL. I=1:2 CON NONIO DIGITALE ±90° adjustable angle driven tool Geared-up I=1:2 with digital display Angetriebenes Werkzeug schwenkbar ±90° uebersetzt I=1:2 mit digital display</p>		OKU336.4.01
<p>MODULO MOTORIZZATO PORTACREATORE Driven gear hobber Angetriebenes Zahnradwaelzfraes-Werkzeug</p>		OKU340.4.00

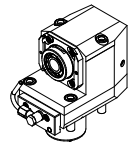
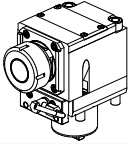
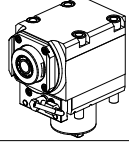
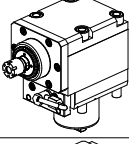
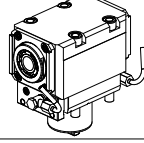
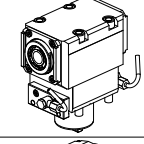
		PAGINA Page Seite
<p>MODULO MOTORIZZATO ASSIALE MTSK PER POWER SKIVING H=85mm Axial MTSK driven tool for Power Skiving H=85mm Axial MTSK angetriebenes Werkzeug fuer Power Skiving H=85mm</p>		OKU350.4.00.K
<p>MODULO MOTORIZZATO PER VITI SENZA FINE Driven tool for worm screws Angetriebenes werkzeug für schrauben ohne ende</p>		OKU359.4.00
<p>MODULO MOTORIZZATO STOZZATORE CORSA 50mm Slotting driven tool 50mm stroke Keilnutenstossmaschine 50mm Hub</p>		OKU360.4.00
<p>MODULO MOTORIZZATO STOZZATORE CORSA 25mm Slotting driven tool 25mm stroke Keilnutenstossmaschine 25mm Hub</p>		OKU360.4.01
<p>MODULO MOTORIZZATO STOZZATORE CORSA 50mm H=100mm Slotting driven tool 50mm stroke H=100mm Keilnutenstossmaschine 50mm Hub H=100mm</p>		OKU360.4.10 NEW
<p>MODULO MOTORIZZATO STOZZATORE CORSA 25mm H=100mm Slotting driven tool 25mm stroke H=100mm Keilnutenstossmaschine 25mm Hub H=100mm</p>		OKU360.4.11 NEW
<p>PORTAUTENSILE RADIALE SINGOLO QD=20mm / QD=3/4" / QD=25mm / QD=1" Radial single static tool QD=20mm / QD=3/4" / QD=25mm / QD=1" Radial Single-Werkzeughalter QD=20mm / QD=3/4" / QD=25mm / QD=1"</p>		OKU423.4.00
<p>PORTAUTENSILE RADIALE SOVRAPPOSTO QD=20mm / QD=3/4" Radial single side twin static tool QD=20mm / QD=3/4" Radial Werkzeughalter ueberlagert QD=20mm / QD=3/4"</p>		OKU440.4.00
<p>PORTAUTENSILE RADIALE DOPPIO QD=20mm / QD=3/4" / QD=25mm / QD=1" Radial double static tool QD=20mm / QD=3/4" / QD=25mm / QD=1" Radial Doppel-Werkzeughalter QD=20mm / QD=3/4" / QD=25mm / QD=1"</p>		OKU450.4.00
<p>PORTAUTENSILE RADIALE DOPPIO SOVRAPPOSTO QD=20mm / QD=3/4" Radial double side twin static tool QD=20mm / QD=3/4" Radial Doppel-Werkzeughalter ueberlagert QD=20mm / QD=3/4"</p>		OKU460.4.00
<p>PORTAUTENSILE RADIALE PER LAMA Radial blade holder Radial Abstechhalter</p>		OKU510.4.00
<p>PORTAUTENSILE PER LAMA DOPPIO Radial double blade holder Radial Doppel-Abstechhalter</p>		OKU520.4.00

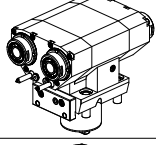
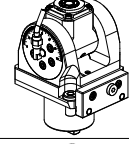
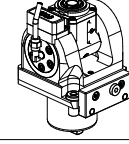
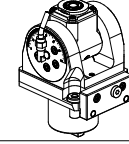
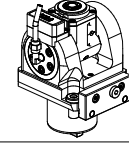
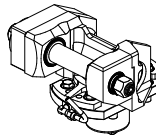
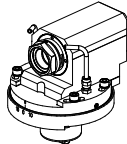
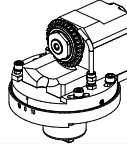
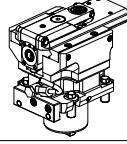
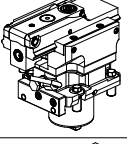
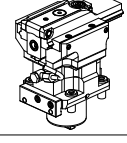
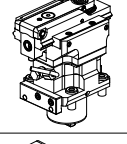
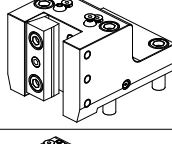
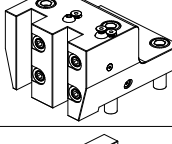
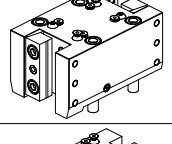
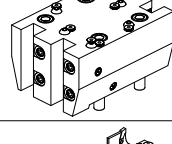
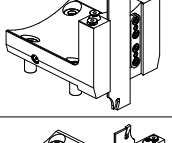
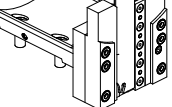
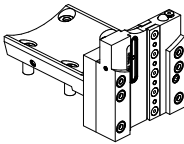
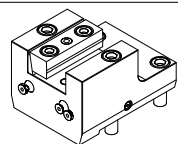
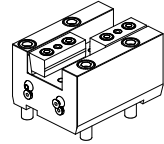
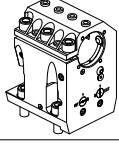
		PAGINA Page Seite
<p>PORTAUTENSILE PER LAMA DOPPIO CON LUBRIFICAZIONE INTERNA Radial double blade holder with internal coolant Radial Doppel-Abstechhalter mit Innenkuehlung</p>		OKU520.4.04
<p>PORTAUTENSILE ASSIALE SINGOLO QD=3/4" / QD=25mm / QD=1" Axial single static tool QD=3/4" / QD=25mm / QD=1" Axial Single-Werkzeughalter QD=3/4" / QD=25mm / QD=1"</p>		OKU552.4.00
<p>PORTAUTENSILE ASSIALE DOPPIO QD=25mm / QD=1" Axial double static tool QD=25mm / QD=1" Axial doppel-Werkzeughalter QD=25mm / QD=1"</p>		OKU572.4.00
<p>PORTAUTENSILE ASSIALE PER BARENO Ø2" H=110mm Axial single boring bar holder Ø2" H=110mm Axial Bohrhalter Ø2" H=110mm</p>		OKU620.4.20 
<p>PORTAUT. ASSIALE PER BARENO Ø32mm/Ø1 1/4"/Ø40mm/Ø1 1/2" H=90mm Axial single boring bar holder Ø32mm/Ø1 1/4"/Ø40mm/Ø1 1/2" H=90mm Axial Bohrhalter Ø32mm/Ø1 1/4"/Ø40mm/Ø1 1/2" H=90mm</p>		OKU630.4.10
<p>PORTAUTENSILE ASSIALE ARRETRATO PER BARENO Ø40mm / Ø1 1/2" Axial rear-set boring bar holder Ø40mm / Ø1 1/2" Axial Bohrhalter zurueckversetzt Ø40mm / Ø1 1/2"</p>		OKU810.4.10
<p>PORTAUT. ASSIALE PER BARENO 2 POSIZ. Ø32mm/Ø1 1/4"/Ø40mm/Ø1 1/2" Axial double boring bar holder Ø32mm/Ø1 1/4"/Ø40mm/Ø1 1/2" Axial Bohrhalter 2 positionen Ø32mm/Ø1 1/4"/Ø40mm/Ø1 1/2"</p>		OKU874.4.00
<p>PORTAUTENSILE ASSIALE PER BARENO 4+4 POSIZIONI Ø25mm Axial 4+4 position boring bar holder Ø25mm Axial Bohrhalter 4+4 positionen Ø25mm</p>		OKU922.4.00
<p>CONTROPUNTA PER CONTROMANDRINO Tailstock for subspindle Gegenspitz fuer Gegenspindel</p>		OKU950.4.00

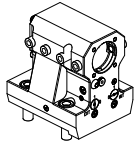
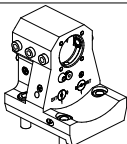
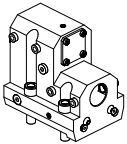
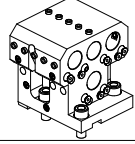
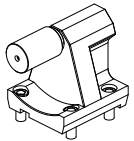
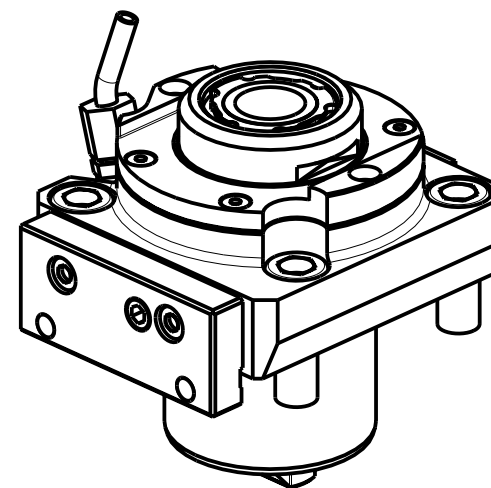
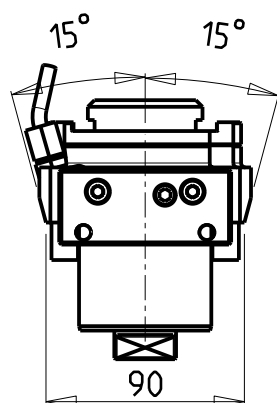
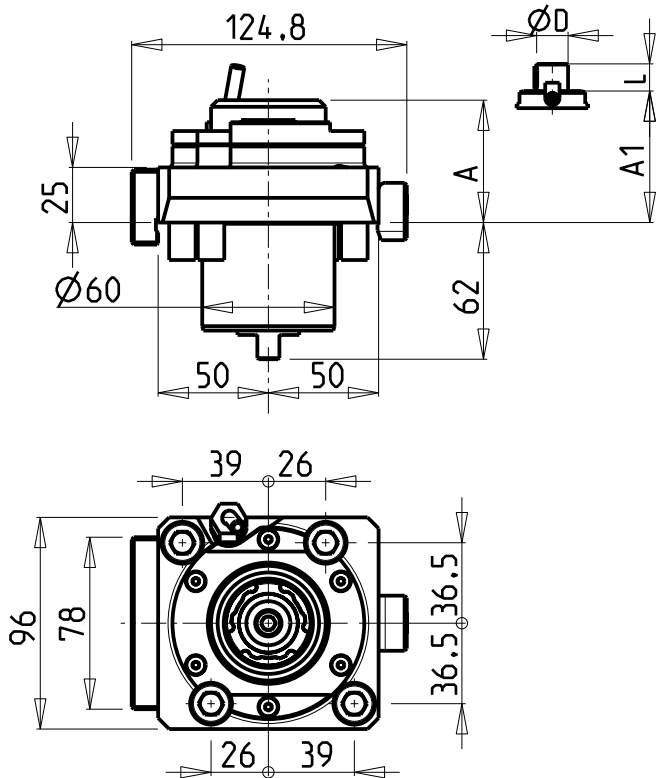

- Chiave inclusa
- Key included
- Schluessel inbegriffen

Cod. MT	Mandrino Spindle Spindel	I	RPM	Coppia Max Max Torque Max Drehmoment	Lubrificazione est. Ext. coolant Aussekkuehlung	Lubrificazione int. Coolant through Innenkuehlung	A	A1	D	L	CHIAVI NON INCLUSE Keys not included Schluessel nicht einbegriffen		
OKU0790132	ERA32	1:1	6000	70Nm	X	-	55.5	-	-	-	CHUB30	CHTAER32ZC	OKU0650004
OKU0790232	ERA32	1:1	6000	70Nm	X	P=30bar	65.5	-	-	-	CHUB30	CHTAER32ZC	OKU0650004
OKU0791617	Ø16x17	1:1	6000	70Nm	X	-	-	50.5	16	17	-	CH_VTCROCE_M08	OKU0650004
OKU0791919	Ø3/4"x3/4"	1:1	6000	70Nm	X	-	-	50.5	3/4"	3/4"	-	CH_VTCROCE_M08	OKU0650004
OKU0792219	Ø22x19	1:1	6000	70Nm	X	-	-	52	22	19	-	CH_VTCROCE_M10	OKU0650004
OKU0792721	Ø27x21	1:1	6000	70Nm	X	-	-	54	27	21	-	CH_VTCROCE_M12	OKU0650004
OKU0792519	Ø1"x19	1:1	6000	70Nm	X	-	-	54	1"	19	-	CH_VTCROCE_M12	OKU0650004

OKUMA
 MOD: LB2000EX - LB2500EX - LB3000EX - LU2000EX - LU2500EX - LU3000EX - MULTUS U3000/4000 2SW
 GENOS L300MW/MYW - GENOS L3000M

MODULO MOTORIZZATO RADIALE
 Radial driven tool
 Radial angetriebenes Werkzeug

Subject to change without notice.

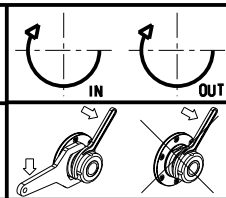

M.T. srl
 Via Casino Albini 480
 Tel. 0541/956034-957884
 Fax 0541/956341
 47842 S. GIOVANNI IN M. (RN)
 e-mail: mtma@mtmarchetti.com
 http://www.mtmarchetti.com

PRODUZIONE MODULI ROTANTI

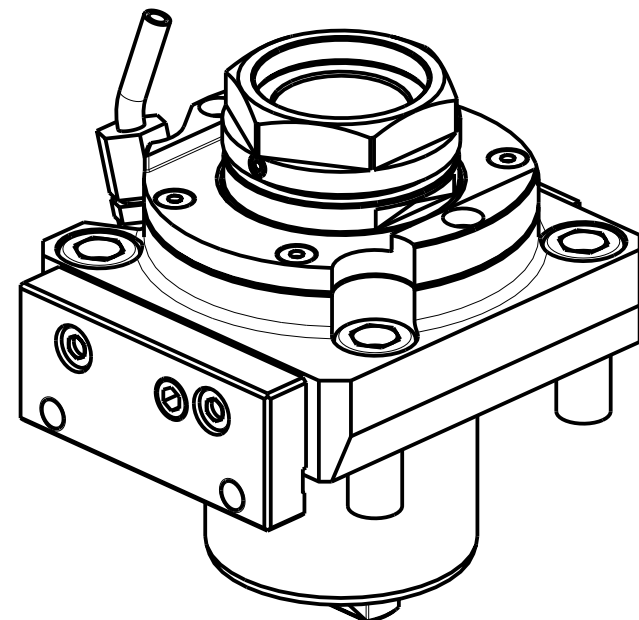
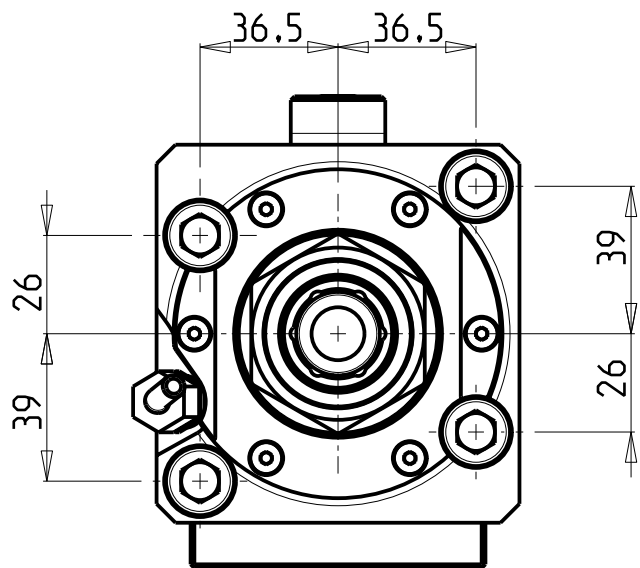
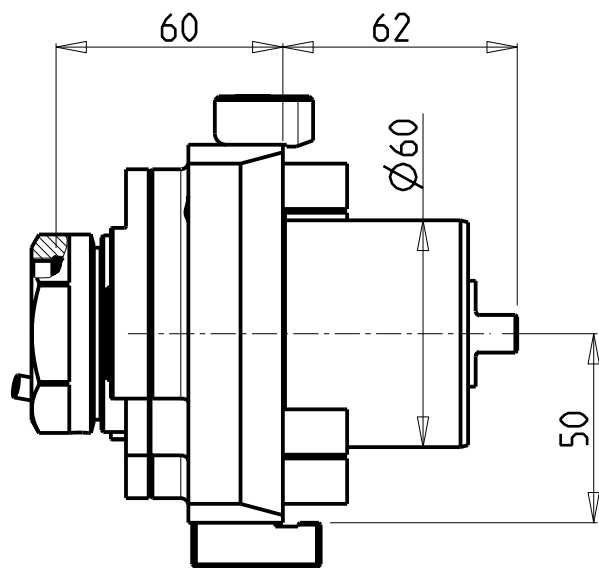
 PAGINA OKU010-4-00



PER PORTAUTENSILI MODULARI MTSK-40 VEDI PAG. TBL300-1-40
 FOR MTSK-40 QUICK CHANGE TOOLHOLDERS CLAMPINGS SEE PAGE TBL300-1-40
 FUER MTSK-40 MODULARE WERKZEUGAUFNAHMEN SIEHE SEITE TBL300-1-40

Cod. MT	Mandrino Spindle Spindel	I	RPM	Coppia Max Max Torque Max Drehmoment	Lubrificazione est. Ext. coolant Aussenkuehlung	CHIAVI NON INCLUSE Keys not included Schluessel nicht einbegriffen	
OKU0750140	MTSK-40	1:1	6000	70Nm	X	CHUB46	OKU0650004 *

- Chiave inclusa
- Key included
- Schluessel inbegriffen

OKUMA
 MOD: LB2000EX - LB2500EX - LB3000EX - LU2000EX - LU2500EX - LU3000EX - MULTUS U3000/4000 2SW
 GENOS L300MW/MYW - GENOS L3000M

MODULO MOTORIZZATO RADIALE MTSK
 Radial MTSK driven tool
 Radial MTSK angetriebenes Werkzeug

Subject to change without notice.

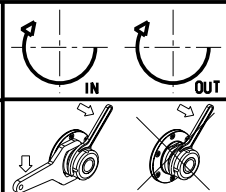

M.T. srl
 Via Casino Albini 480
 Tel. 0541/956034-957884
 Fax 0541/956341
 47842 S. GIOVANNI IN M. (RN)
 e-mail: mtma@mtmarchetti.com
 http://www.mtmarchetti.com

PRODUZIONE MODULI ROTANTI

PAGINA OKU010-4-00-K

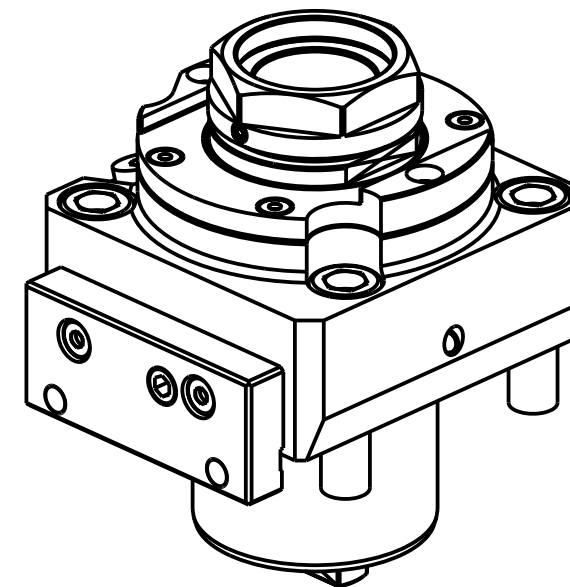
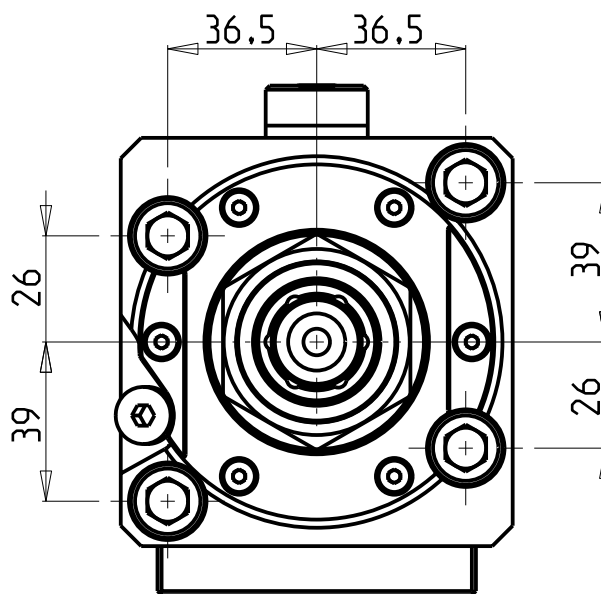
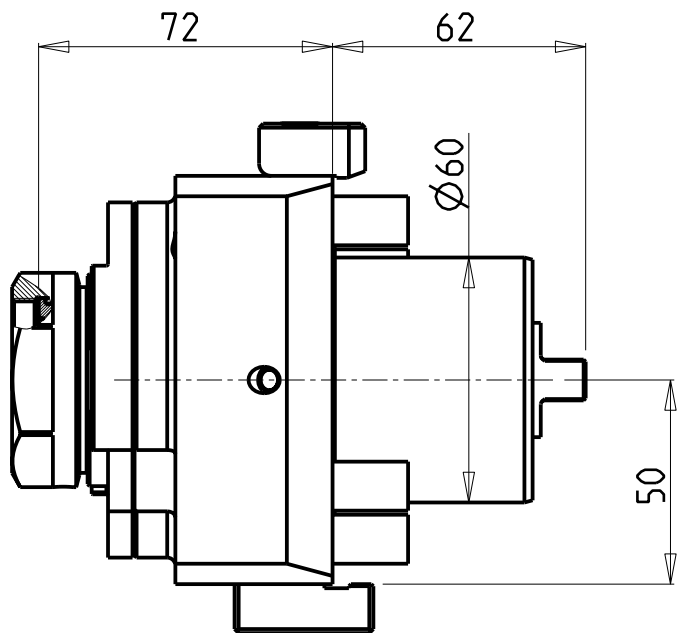

PER PORTAUTENSILI MODULARI MTSK-40 VEDI PAG. TBL300-1-40
 FOR MTSK-40 QUICK CHANGE TOOLHOLDERS CLAMPINGS SEE PAGE TBL300-1-40
 FUER MTSK-40 MODULARE WERKZEUGAUFNAHMEN SIEHE SEITE TBL300-1-40

Cod. MT	Mandrino Spindle Spindel	I	RPM	Coppia Max Max Torque Max Drehmoment	Lubr.interna Coolant through Innenkuehlung	Lubrificazione est. Ext. coolant Aussenkuehlung	CHIAVI NON INCLUSE Keys not included Schluessel nicht einbegriffen	
OKU1580140	MTSK-40	1:1	6000	70Nm	P=70bar	X	CHUB46	OKU0650004 *

- Chiave inclusa
- Key included
- Schluessel inbegriffen

OKUMA

MOD: LB2000EX - LB2500EX - LB3000EX - LU2000EX - LU2500EX - LU3000EX - MULTUS U3000/4000 2SW
 GENOS L300MW/MYW - GENOS L3000M

MODULO MOTORIZZATO RADIALE ALTA PRESSIONE MTSK

Radial MTSK driven tool high pressure

Radial MTSK angetriebenes Werkzeug hochdruck

Subject to change without notice.

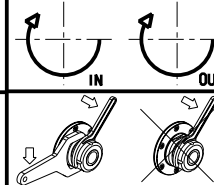

M.T. srl

Via Casino Albini 480
 Tel. 0541/956034-957884
 Fax 0541/956341
 47842 S. GIOVANNI IN M. (RN)
 e-mail: mtma@mtmarchetti.com
 http://www.mtmarchetti.com

PRODUZIONE MODULI ROTANTI



PAGINA OKU010-4-20-K

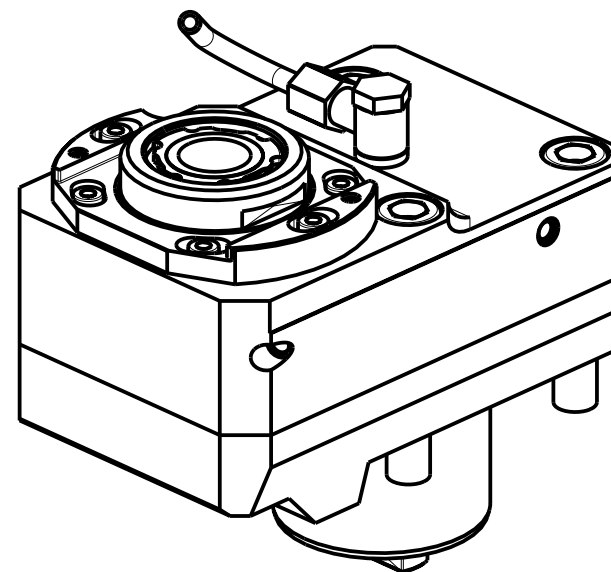
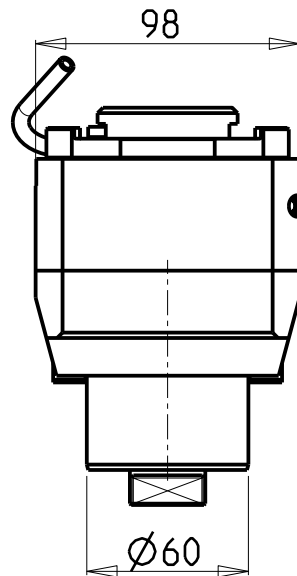
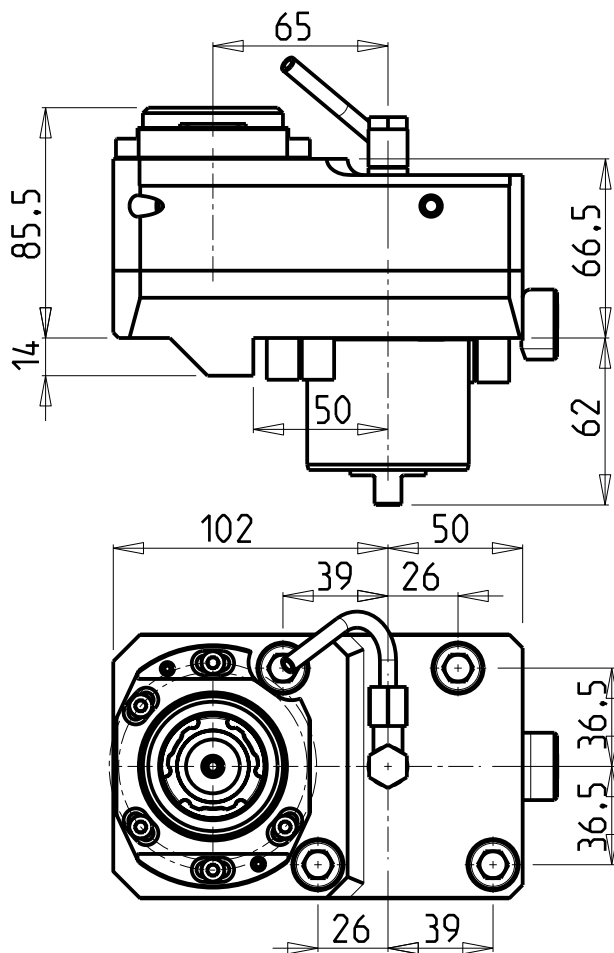

- Chiave inclusa
- Key included
- Schlüssel inbegriffen

Cod. MT	Mandrino Spindle Spindel	i	RPM	Coppia Max Max Torque Max Drehmoment	Reversibile lato mandrino/contromandrino Reversible sub/main spindle side Umkehrbare Spindelseite/ Gegenspindelseite	Lubr.interna Coolant through Innenkuehlung	Lubr.esterna Ext. coolant Aussenkuehlung	CHIAVI NON INCLUSE Keys not included Schlüssel nicht einbegriffen		
								CHUB30	CHTAER32ZC	OKU0650004
OKU0311132	ERA32	1:1	6000	50Nm	X	-	X	CHUB30	CHTAER32ZC	OKU0650004
OKU0312232	ERA32	1:1	6000	50Nm	X	P=70bar	X	CHUB30	CHTAER32ZC	OKU0650004

OKUMA
 MOD: LB2000EX - LB2500EX - LB3000EX - LU2000EX - LU2500EX - LU3000EX - MULTUS U3000/4000 2SW
 GENOS L300MW/MYW - GENOS L3000M

MODULO MOTORIZZATO RADIALE DISASSATO IN Z 65mm
 Radial driven tool re-directed in Z by 65mm
 Radial angetriebenes Werkzeug achsversetzt in Z um 65mm

Subject to change without notice.

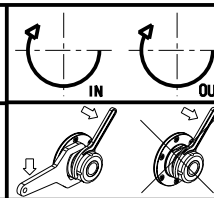

M.T. srl
 Via Casino Albini 480
 Tel. 0541/956034-957884
 Fax 0541/956341
 47842 S. GIOVANNI IN M. (RN)
 e-mail: mtma@mtmarchetti.com
 http://www.mtmarchetti.com

PRODUZIONE MODULI ROTANTI



PAGINA OKU030-4-10

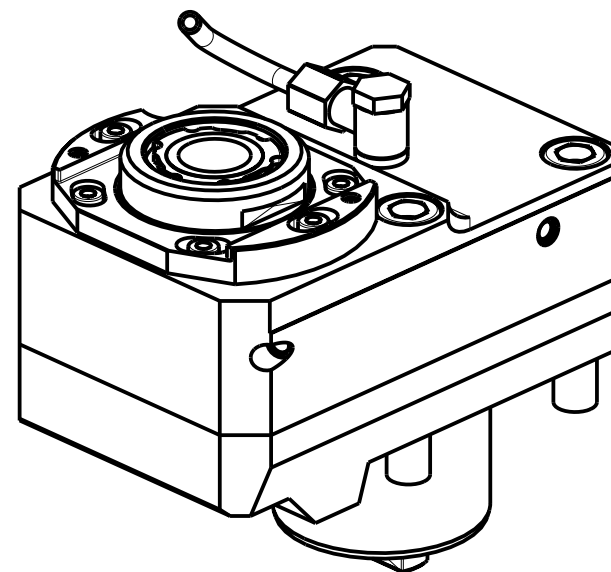
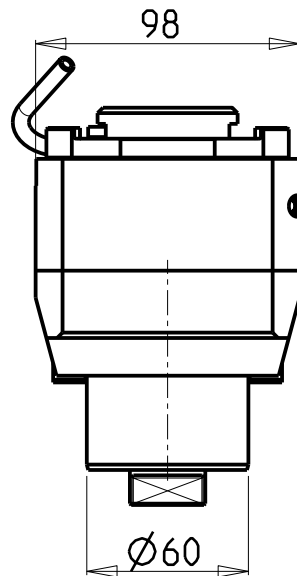
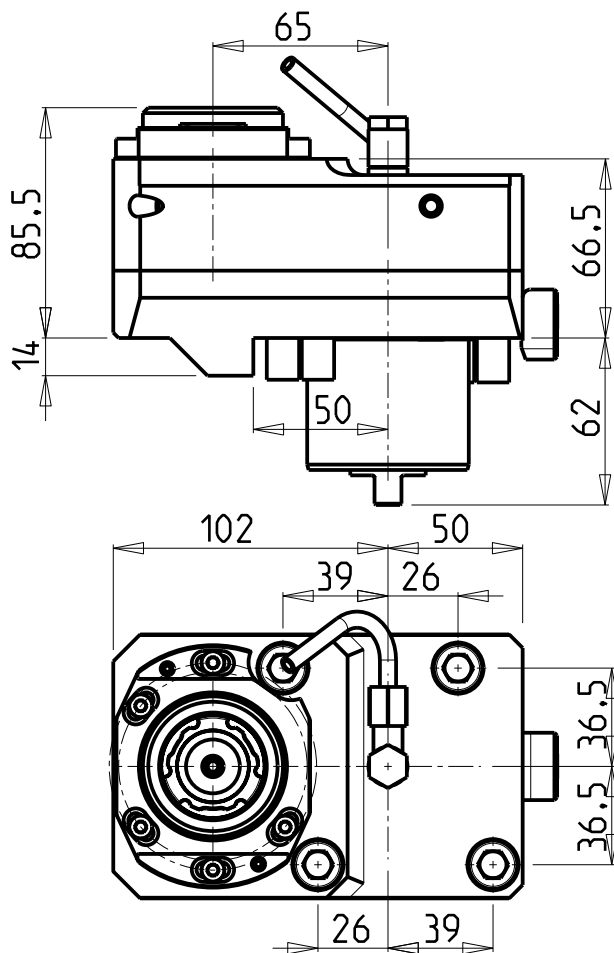

- Chiave inclusa
- Key included
- Schlüssel inbegriffen

Cod. MT	Mandrino Spindle Spindel	i	RPM	Coppia Max Max Torque Max Drehmoment	Reversibile lato mandrino/contromandrino Reversible sub/main spindle side Umkehrbare Spindelseite/ Gegenspindelseite	Lubr.interna Coolant through Innenkuehlung	Lubr.esterna Ext. coolant Aussenkuehlung	CHIAVI NON INCLUSE Keys not included Schlüssel nicht einbegriffen		
								CHUB30	CHTAER32ZC	OKU0650004
OKU0312132	ERA32	2:1	3000	70Nm	X	-	X	CHUB30	CHTAER32ZC	OKU0650004
OKU0314232	ERA32	2:1	3000	70Nm	X	P=70bar	X	CHUB30	CHTAER32ZC	OKU0650004

OKUMA
 MOD: LB2000EX - LB2500EX - LB3000EX - LU2000EX - LU2500EX - LU3000EX - MULTUS U3000/4000 2SW
 GENOS L300MW/MYW - GENOS L3000M

MODULO MOTORIZZATO RADIALE RIDOTTO I=2:1 DISASSATO IN Z 65mm
 Radial geared-down I=2:1 driven tool re-directed in Z by 65mm
 Radial angetriebenes Werkzeug untersetzt I=2:1 achsversetzt in Z um 65mm

Subject to change without notice.

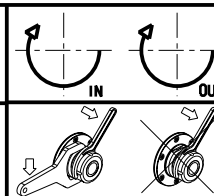

M.T. srl
 Via Casino Albini 480
 Tel. 0541/956034-957884
 Fax 0541/956341
 47842 S. GIOVANNI IN M. (RN)
 e-mail: mtma@mtmarchetti.com
 http://www.mtmarchetti.com

PRODUZIONE MODULI ROTANTI



PAGINA OKU030-4-20

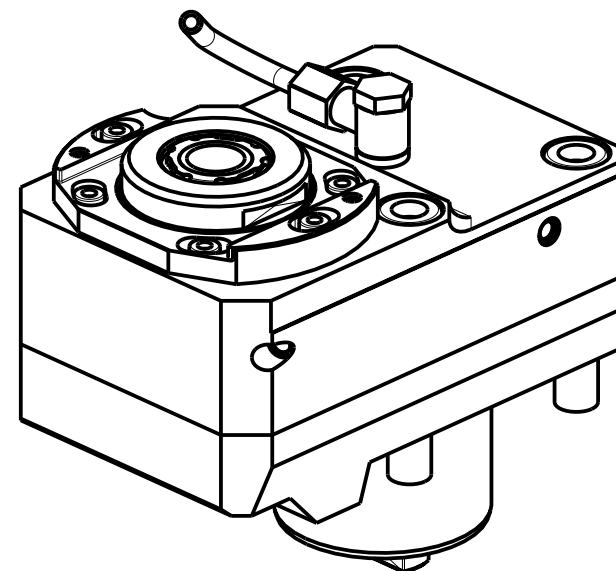
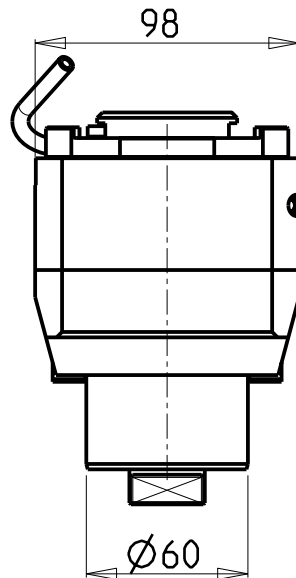
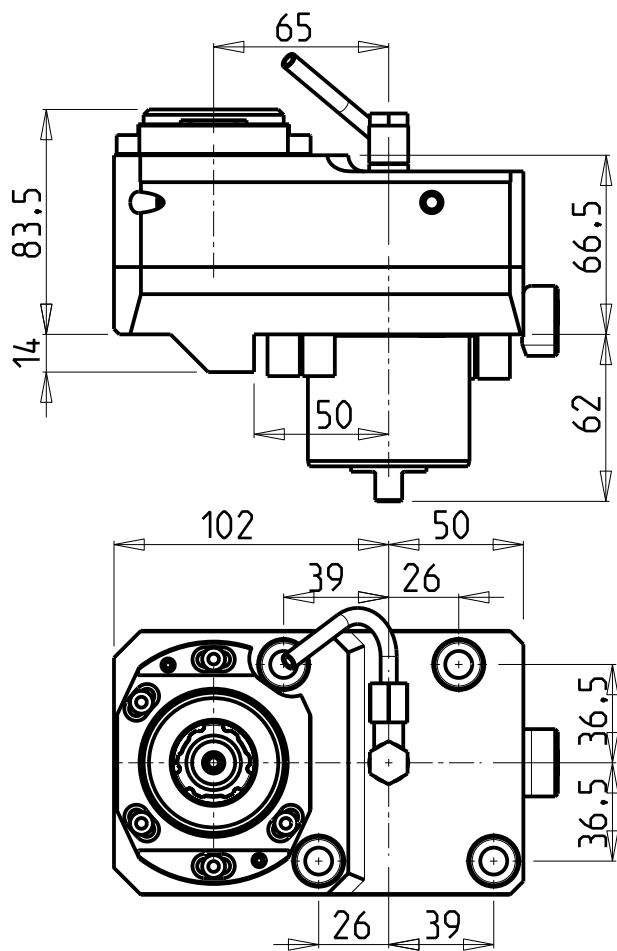

- Chiave inclusa
- Key included
- Schlüssel inbegriffen

Cod. MT	Mandrino Spindle Spindel	i	RPM	Coppia Max Max Torque Max Drehmoment	Reversibile lato mandrino/contromandrino Reversible sub/main spindle side Umkehrbare Spindelseite/ Gegenspindelseite	Lubr.interna Coolant through Innenkuehlung	Lubr.esterna Ext. coolant Aussenkuehlung	CHIAVI NON INCLUDE Keys not included Schlüssel nicht einbegriffen		
								CHUB27	CHTAER25ZC	OKU0650004
OKU0311225	ERA25	1:2	12000	30Nm	X	-	X	CHUB27	CHTAER25ZC	OKU0650004
OKU0312425	ERA25	1:2	12000	30Nm	X	P=70bar	X	CHUB27	CHTAER25ZC	OKU0650004

OKUMA
 MOD: LB2000EX - LB2500EX - LB3000EX - LU2000EX - LU2500EX - LU3000EX - MULTUS U3000/4000 2SW
 GENOS L300MW/MYW - GENOS L3000M

MODULO MOTORIZZATO RADIALE MOLTIPLICATO I=1:2 DISASSATO IN Z 65mm
 Radial geared-up I=1:2 driven tool re-directed in Z by 65mm
 Radial angetriebenes Werkzeug uebersetzt I=1:2 achsversetzt in Z um 65mm

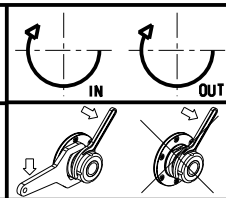

M.T. srl
 Via Casino Albini 480
 Tel. 0541/956034-957884
 Fax 0541/956341
 47842 S. GIOVANNI IN M. (RN)
 e-mail: mtma@mtmarchetti.com
 http://www.mtmarchetti.com

PRODUZIONE MODULI ROTANTI

 PAGINA OKU030-4-30

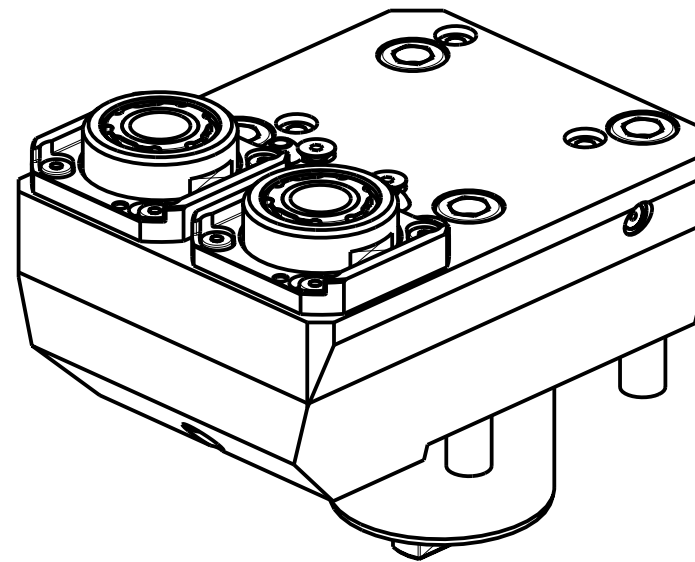
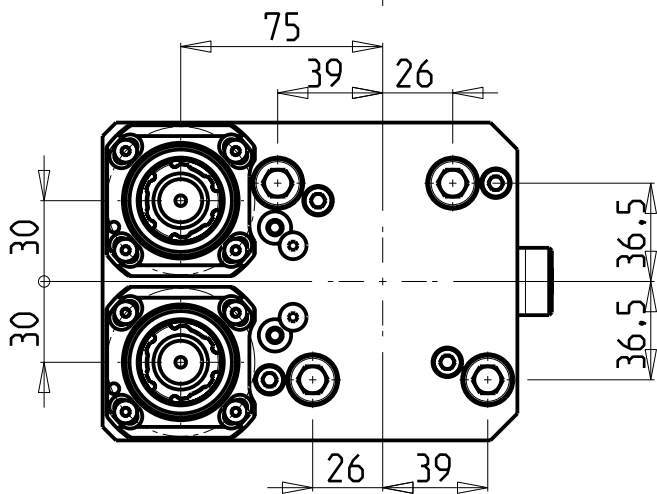
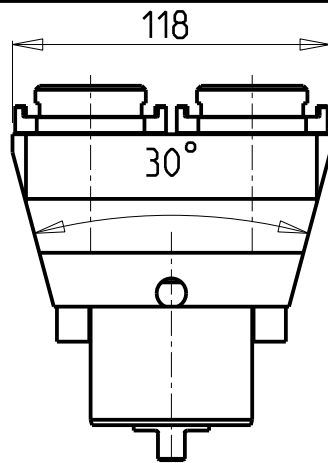
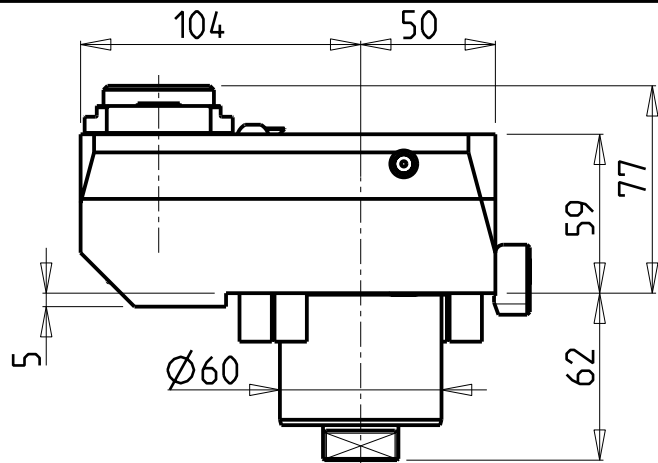
Subject to change without notice.



ATTENZIONE - ATTENTION - ACHTUNG

- Per lo smontaggio degli utensili utilizzare sempre la chiave di contrasto come indicato nel manuale d'uso.
- For disassembly of the tools use always the contrast key as mentioned in the user instructions.
- Fuer das Abmontieren der Werkzeuge immer den Gegenschlüssel benutzen wie in der Bedienungsanleitung erwaeht.

- Chiave inclusa
- Key included
- Schlüssel inbegriffen

Cod. MT	Mandrino Spindel Spindel	I	RPM	Coppia Max Max Torque Max Drehmoment	Lubrificazione int. Coolant through Innenkuehlung	Lubrificazione est. Ext. coolant Aussenkuehlung	Reversibile lato mandrino/controlmandrino Reversible sub/main spindle side Umkehrbare Spindel-seite/Gegenspindel-seite	CHIAVI NON INCLUSE Keys not included Schlüssel nicht inbegriffen		
OKU0290125	ERA25	1:1	6000	50Nm		X	X	CHUB27	CHTAER25ZC	OKU0290009
OKU0290225	ERA25	1:1	6000	50Nm	P=70bar	X	X	CHUB27	CHTAER25ZC	OKU0290009

OKUMA
 MOD: LB2000EX - LB2500EX - LB3000EX - LU2000EX - LU2500EX - LU3000EX - GENOS L300MW/MYW - GENOS L3000M

MODULO MOTORIZZATO RADIALE 2 USCITE SOVRAPPOSTE
 Radial single side twin head driven tool
 Radial angetriebenes Werkzeug 2 Ausgaenge ueberlagert

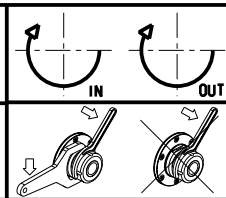

M.T. srl
 Via Casino Albini 480
 Tel. 0541/956034-957884
 Fax 0541/956341
 47842 S. GIOVANNI IN M. (RN)
 e-mail: mtma@mtmarchetti.com
 http://www.mtmarchetti.com

PRODUZIONE MODULI ROTANTI

PAGINA OKU090-4-00

Subject to change without notice.

ATTENZIONE - ATTENTION - ACHTUNG

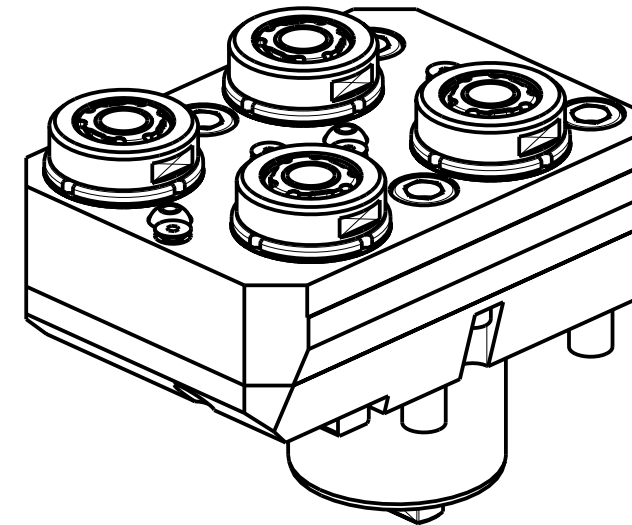
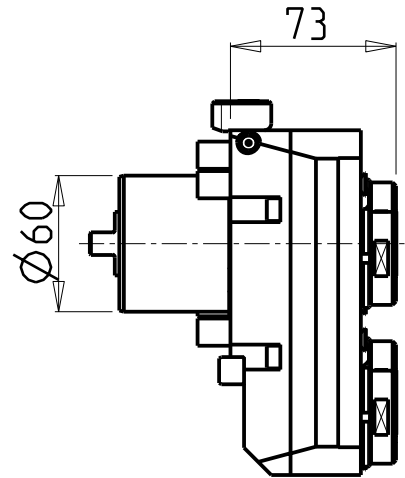
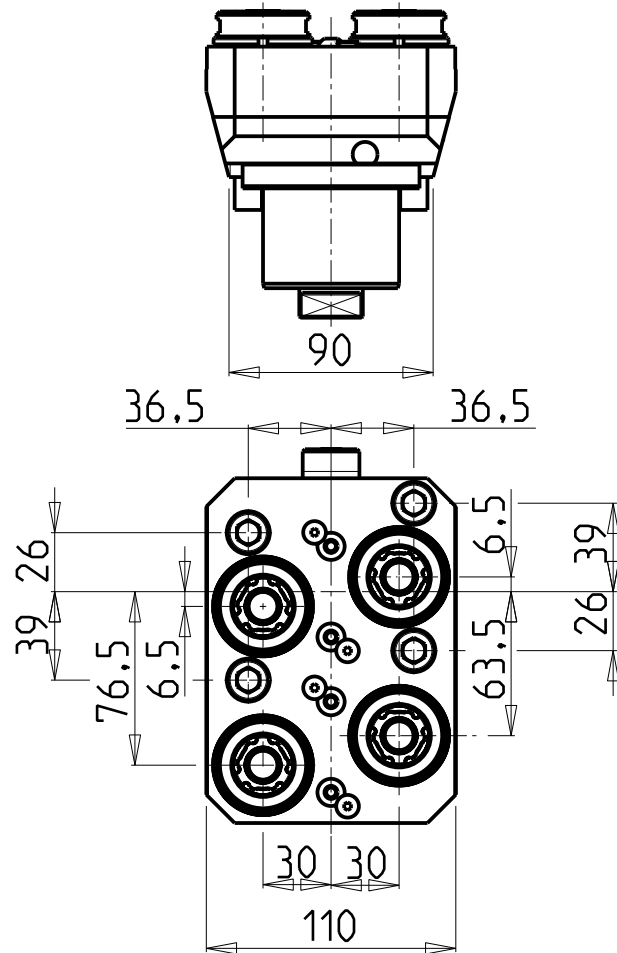
- Per lo smontaggio degli utensili utilizzare sempre la chiave di contrasto come indicato nel manuale d'uso.
- For disassembly of the tools use always the contrast key as mentioned in the user instructions.
- Fuer das Abmontieren der Werkzeuge immer den Gegenschlüssel benutzen wie in der Bedienungsanleitung erwahnt.



Cod. MT	Mandrino Spindle Spindel	I	RPM	Coppia Max Max Torque Max Drehmoment	N°Utensili N°Tools N°Werkzeuge	Reversibile lato mandrino/contromandrino Reversible sub/main spindle side Umkehrbare Spindel-seite/Gegenspindel-seite	Lubrificazione est. Ext. coolant Aussenkuehlung	CHIAVI INCLUSE Keys included Schluessel einbegriffen		
OKU1330125	ERA20	1:1	6000	30Nm	4	X	X	CHUB22	CHUB38	CHTAER20ZC •

- Chiave inclusa
- Key included
- Schluessel inbegriffen

OKUMA
 MOD: LB2000EX - LB2500EX - LB3000EX - LU2000EX - LU2500EX - LU3000EX - GENOS L300MW /MYW - GENOS L3000M

MODULO MOTORIZZATO RADIALE 4 USCITE
 Radial 4 head driven tool
 Radial angetriebenes Werkzeug 4 Ausgaenge

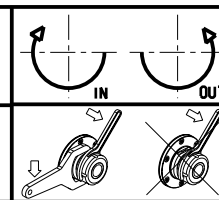

M.T. srl
 Via Casino Albini 480
 Tel. 0541/956034-957884
 Fax 0541/956341
 47842 S. GIOVANNI IN M. (RN)
 e-mail: mtma@mtmarchetti.com
 http://www.mtmarchetti.com

PRODUZIONE MODULI ROTANTI



PAGINA OKU100-4-00

Subject to change without notice.

ATTENZIONE - ATTENTION - ACHTUNG

- Per lo smontaggio degli utensili utilizzare sempre la chiave di contrasto come indicato nel manuale d'uso.
- For disassembly of the tools use always the contrast key as mentioned in the user instructions.
- Fuer das Abmontieren der Werkzeuge immer den Gegenschuessel benutzen wie in der Bedienungsanleitung erwaeht.

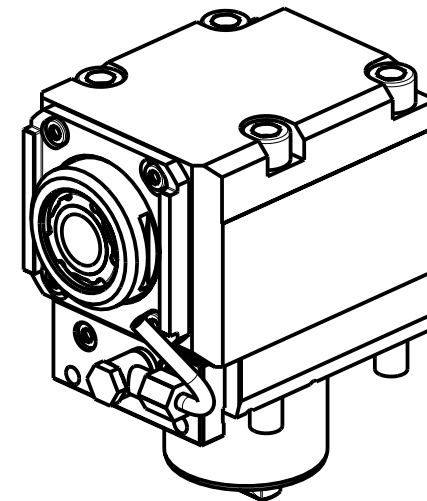
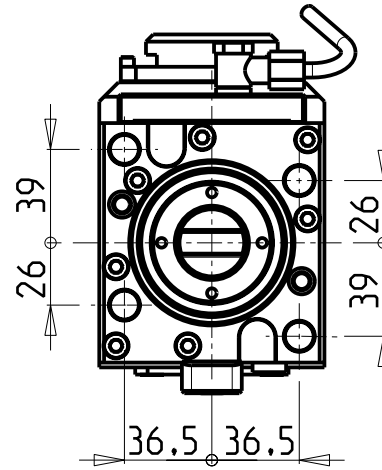
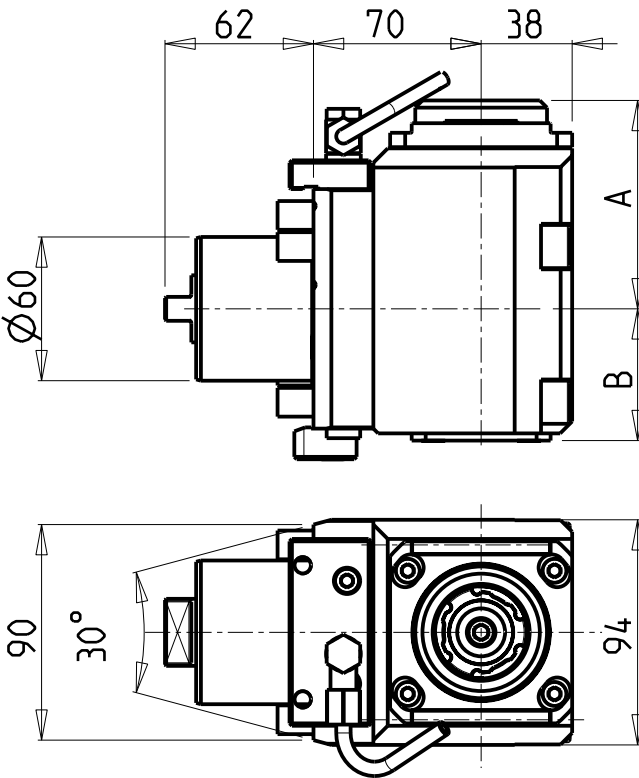

- Chiave inclusa
- Key included
- Schuessel inbegriffen

Cod. MT	Mandrino Spindel Spindel	I	RPM	Coppia Max Max Torque Max Drehmoment	Reversibile lato mandrino/contromandrino Reversible sub/main spindle side Umkehrbare Spindelsetseite/ Gegenspindelsetseite	Lubr.interna Coolant through Innenkuehlung	Lubr.esterna Ext. coolant Aussenkuehlung	A	B	CHIAVI NON INCLUSE Keys not included Schuessel nicht einbegriffen		
OKU0780132	ERA32	1:1	6000	70Nm	X	-	X	87	55	CHUB30	OKU0650004	CHTAER32ZC
OKU0780232	ERA32	1:1	6000	70Nm	X	P=70bar	X	87	63.5	CHUB30	OKU0650004	CHTAER32ZC
OKU0780340	ER40	1:1	6000	70Nm	X	-	X	111.66	55	-	OKU0650004	CHSTER40
OKU0780440	ER40	1:1	6000	70Nm	X	P=70bar	X	111.66	63.5	-	OKU0650004	CHSTER40

OKUMA
 MOD: LB2000EX - LB2500EX - LB3000EX - LU2000EX - LU2500EX - LU3000EX - GENOS L300MW/MYW - GENOS L3000M

MODULO MOTORIZZATO ASSIALE H=70mm
 Axial driven tool H=70mm
 Axial angetriebenes Werkzeug H=70mm

Subject to change without notice.

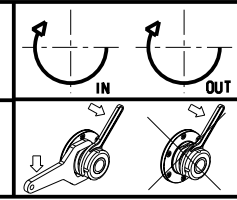

M.T. srl
 Via Casino Albini 480
 Tel. 0541/956034-957884
 Fax 0541/956341
 47842 S. GIOVANNI IN M. (RN)
 e-mail: mtma@mtmarchetti.com
 http://www.mtmarchetti.com

PRODUZIONE MODULI ROTANTI

PAGINA OKU150-4-10

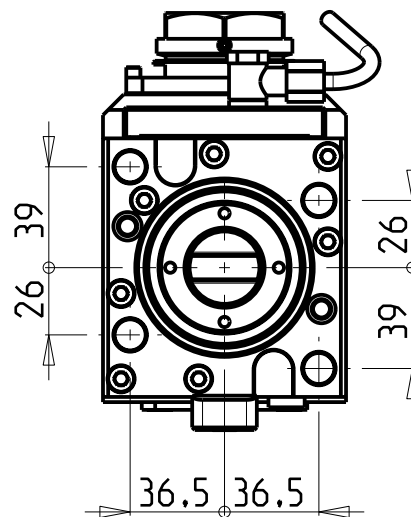
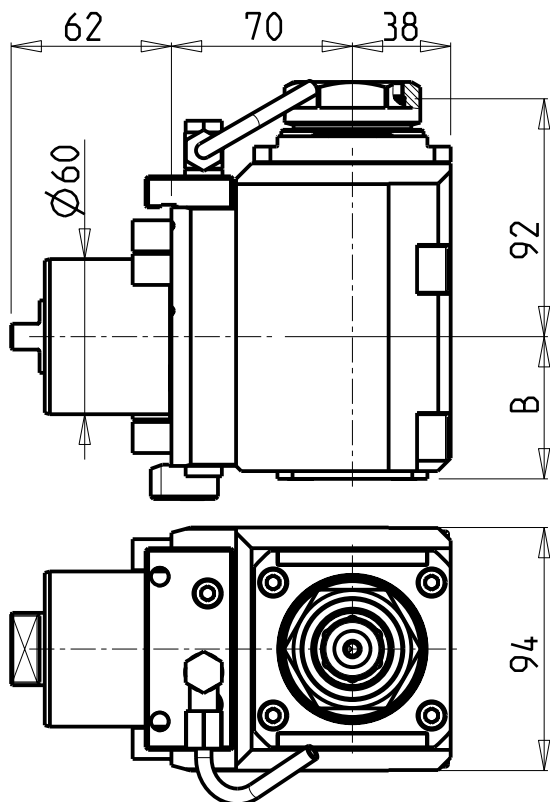

ATTENZIONE - ATTENTION - ACHTUNG

- Per lo smontaggio degli utensili utilizzare sempre la chiave di contrasto come indicato nel manuale d'uso.
- For disassembly of the tools use always the contrast key as mentioned in the user instructions.
- Fuer das Abmontieren der Werkzeuge immer den Gegenschlüssel benutzen wie in der Bedienungsanleitung erwaeht.

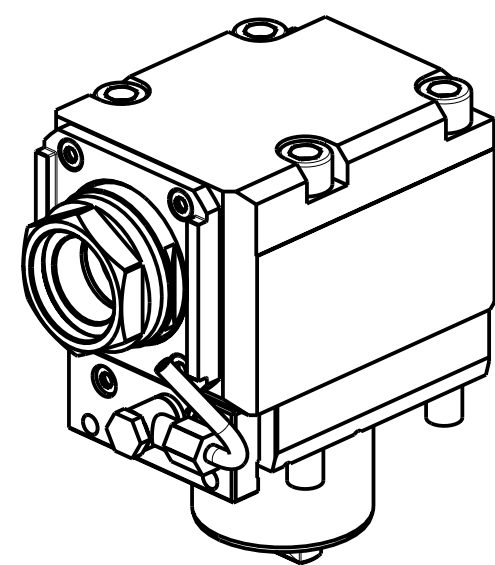

PER PORTAUTENSILI MODULARI MTSK-40 VEDI PAG. TBL300-1-40
 FOR MTSK-40 QUIK CHANGE TOOLHOLDERS CLAMPINGS SEE PAGE TBL300-1-40
 FUER MTSK-40 MODULARE WERKZEUGAUFNAHMEN SIEHE SEITE TBL300-1-40

Cod. MT	Mandrino Spindle Spindel	I	RPM	Coppia Max Max Torque Max Drehmoment	Reversibile lato mandrino/contromandrino Reversible sub/main spindle side Umkehrbare Spindel-seite/ Gegenspindel-seite	Lubr.interna Coolant through Innenkuehlung	Lubr.esterna Ext. coolant Aussenkuehlung	B	CHIAVI NON INCLUSE Keys not included Schlüssel nicht einbegriffen	
OKU0740140	MTSK-40	1:1	6000	70Nm	X	-	X	55	CHUB46	OKU0650004 ■
OKU0740240	MTSK-40	1:1	6000	70Nm	X	P=70bar	X	63.5	CHUB46	OKU0650004 ■

- Chiave inclusa
- Key included
- Schlüssel inbegriffen

OKUMA
 MOD: LB2000EX - LB2500EX - LB3000EX - LU2000EX - LU2500EX - LU3000EX - GENOS L300MW /MYW - GENOS L3000M

MODULO MOTORIZZATO ASSIALE MTSK H=70mm
 Axial MTSK driven tool H=70mm
 Axial MTSK angetriebenes Werkzeug H=70mm

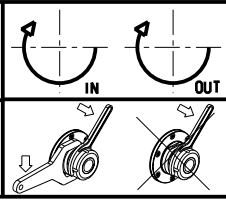

M.T. srl
 Via Casino Albini 480
 Tel. 0541/956034-957884
 Fax 0541/956341
 47842 S. GIOVANNI IN M. (RN)
 e-mail: mtma@mtmarchetti.com
 http://www.mtmarchetti.com

PRODUZIONE MODULI ROTANTI



PAGINA OKU150-4-10-K

Subject to change without notice.

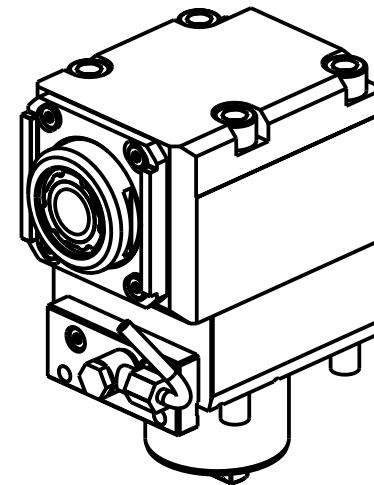
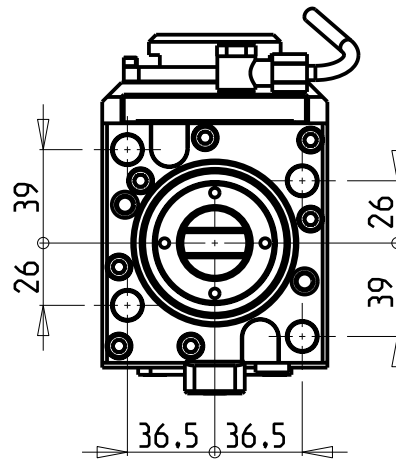
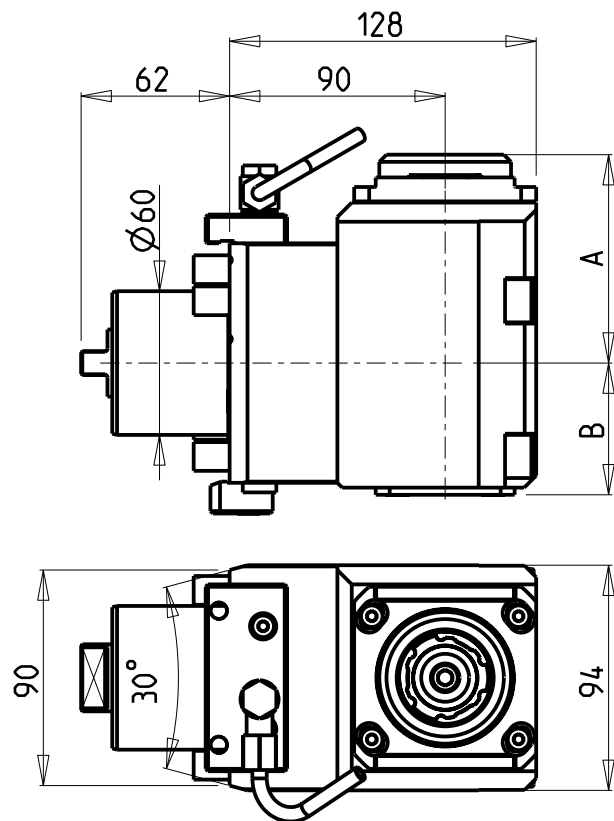

ATTENZIONE - ATTENTION - ACHTUNG

- Per lo smontaggio degli utensili utilizzare sempre la chiave di contrasto come indicato nel manuale d'uso.
- For disassembly of the tools use always the contrast key as mentioned in the user instructions.
- Fuer das Abmontieren der Werkzeuge immer den Gegenschluessel benutzen wie in der Bedienungsanleitung erwaeht.

- Chiave inclusa
- Key included
- Schluessel inbegriffen

CHIAVI NON INCLUSE
Keys not included
Schluessel nicht einbegriffen

Cod. MT	Mandrino Spindle Spindel	I	RPM	Coppia Max Max Torque Max Drehmoment	Reversibile lato mandrino/contromandrino Reversible sub/main spindle side Umkehrbare Spindel-seite/ Gegenspindel-seite	Lubr.interna Coolant through Innenkuehlung	Lubr.esterna Ext. coolant Aussenkuehlung	A	B				
OKU1640132	ERA32	1:1	6000	70Nm	X	-	X	87	55	CHUB30	OKU0650004	CHTAER32ZC	NEW
OKU1640232	ERA32	1:1	6000	70Nm	X	P=70bar	X	87	63.5	CHUB30	OKU0650004	CHTAER32ZC	NEW
OKU1640340	ER40	1:1	6000	70Nm	X	-	X	111.66	55	-	OKU0650004	CHSTER40	NEW
OKU1640440	ER40	1:1	6000	70Nm	X	P=70bar	X	111.66	63.5	-	OKU0650004	CHSTER40	NEW

OKUMA

MOD: MULTUS U3000/4000 2SW - GENOS L300MW/MYW

MODULO MOTORIZZATO ASSIALE H=90mm

Axial driven tool H=90mm

Axial angetriebenes Werkzeug H=90mm

Subject to change without notice.

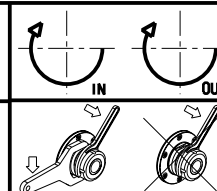

M.T. srl

Via Casino Albini 480
Tel. 0541/956034-957884
Fax 0541/956341
47842 S. GIOVANNI IN M. (RN)
e-mail: mtma@mtmarchetti.com
http://www.mtmarchetti.com

PRODUZIONE MODULI ROTANTI



PAGINA OKU150-4-20

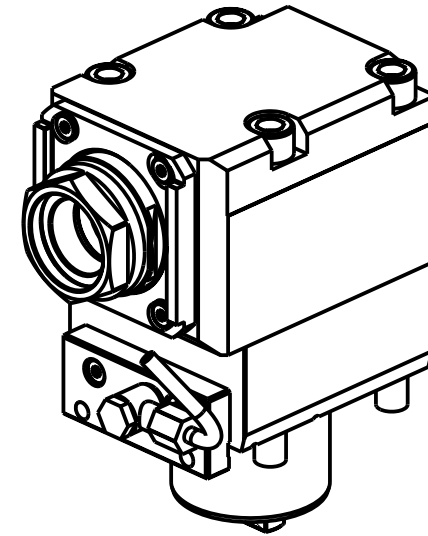
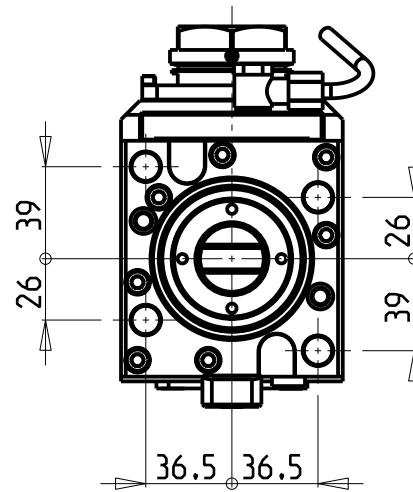
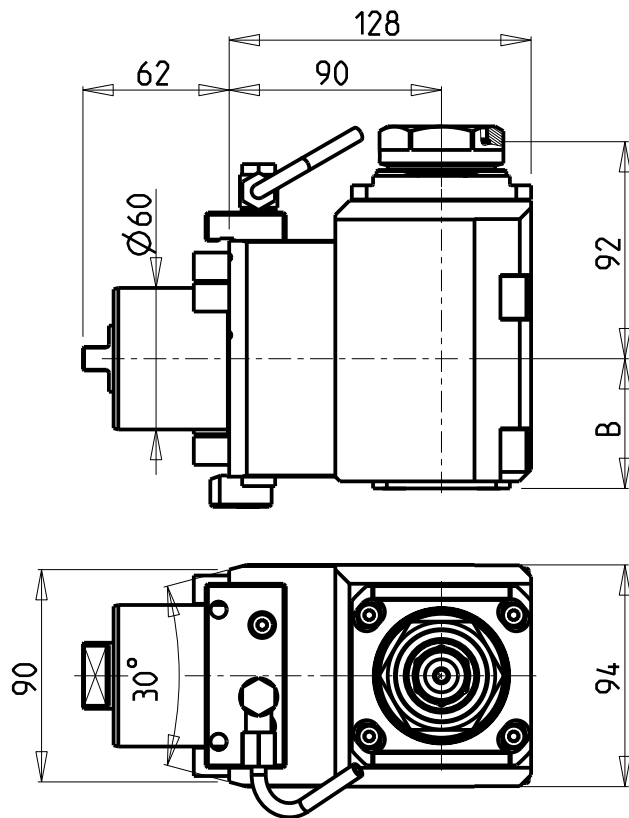

ATTENZIONE - ATTENTION - ACHTUNG

- Per lo smontaggio degli utensili utilizzare sempre la chiave di contrasto come indicato nel manuale d'uso.
- For disassembly of the tools use always the contrast key as mentioned in the user instructions.
- Fuer das Abmontieren der Werkzeuge immer den Gegenschlüssel benutzen wie in der Bedienungsanleitung erwaeht.

PER PORTAUTENSILI MODULARI MTSK-40 VEDI PAG. TBL300-1-40
 FOR MTSK-40 QUICK CHANGE TOOLHOLDERS CLAMPINGS SEE PAGE TBL300-1-40
 FUER MTSK-40 MODULARE WERKZEUGAUFNAHMEN SIEHE SEITE TBL300-1-40

Cod. MT	Mandrino Spindle Spindel	I	RPM	Coppia Max Max Torque Max Drehmoment	Reversibile lato mandrino/contromandrino Reversible sub/main spindle side Umkehrbare Spindel-seite/ Gegenspindel-seite	Lubr.interna Coolant through Innenkuehlung	Lubr.esterna Ext. coolant Aussenkuehlung	B	CHIAVI NON INCLUDE Keys not included Schluessel nicht einbegriffen	
OKU1650140	MTSK-40	1:1	6000	70Nm	X	-	X	55	CHUB46	OKU0650004 ■
OKU1650240	MTSK-40	1:1	6000	70Nm	X	P=70bar	X	63.5	CHUB46	OKU0650004 ■

- Chiave inclusa
- Key included
- Schluessel inbegriffen

NEW
NEW

OKUMA
 MOD: MULTUS U3000/4000 2SW - GENOS L300MW/MYW

MODULO MOTORIZZATO ASSIALE MTSK H=90mm
 Axial MTSK driven tool H=90mm
 Axial MTSK angetriebenes Werkzeug H=90mm

Subject to change without notice.

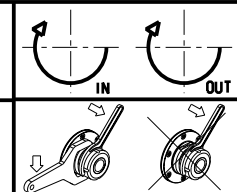

M.T. srl
 Via Casino Albini 480
 Tel. 0541/956034-957884
 Fax 0541/956341
 47842 S. GIOVANNI IN M. (RN)
 e-mail: mtma@mtmarchetti.com
 http://www.mtmarchetti.com

PRODUZIONE MODULI ROTANTI



PAGINA OKU150-4-20-K

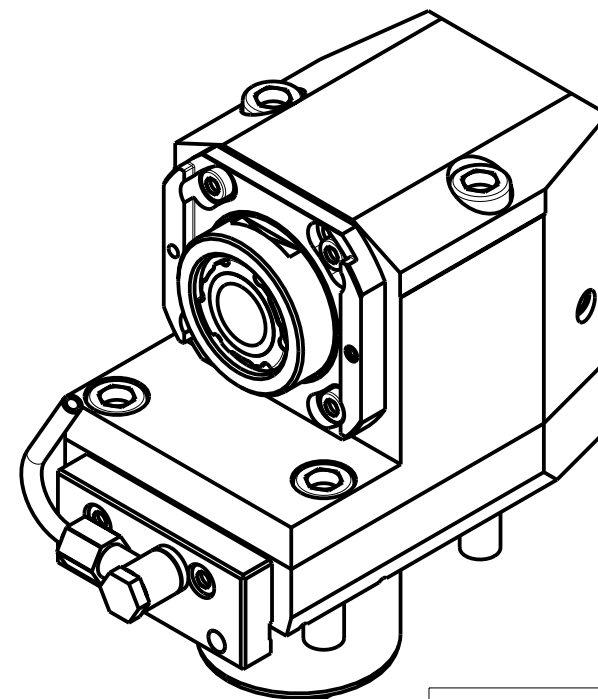
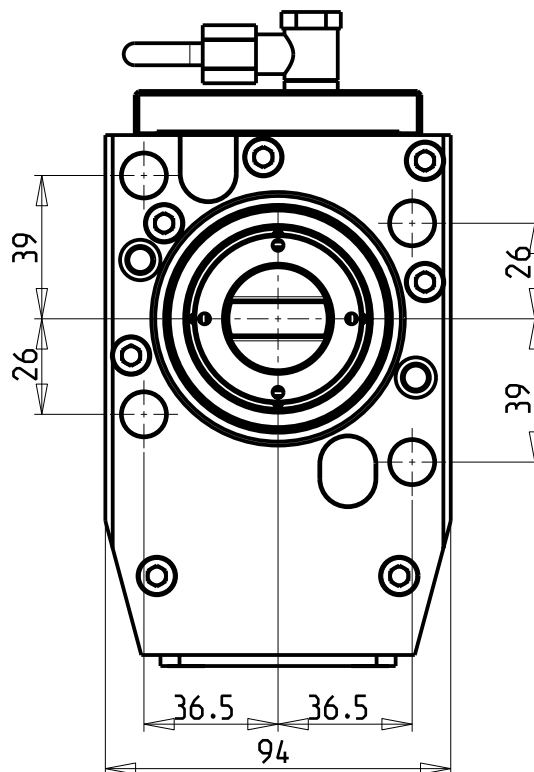
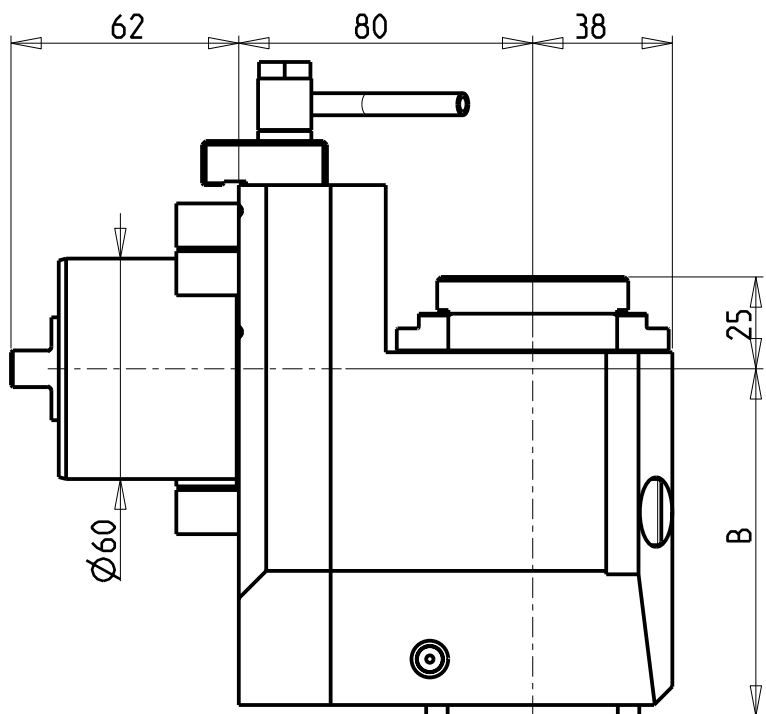

- Chiave inclusa
- Key included
- Schluessel inbegriffen

Cod. MT	Mandrino Spindle Spindel	i	RPM	Coppia Max Max Torque Max Drehmoment	Reversibile lato mandrino/contromandrino Reversible sub/main spindle side Umkehrbare Spindelseite/ Gegenspindelseite	Lubrificazione int. Coolant through Innenkuehlung	Lubrificazione est. Ext. coolant Aussenkuehlung	B	CHIAVI NON INCLUSE Keys not included Schluessel nicht einbegriffen		
OKU0770132	ERA32	1:1	6000	70Nm	X		X	94.5	CHUB30	CHTAER32ZC	OKU0650004
OKU0770232	ERA32	1:1	6000	70Nm	X	P=70bar	X	103	CHUB30	CHTAER32ZC	OKU0650004

OKUMA
 MOD: LB2000EX - LB2500EX - LB3000EX - LU2000EX - LU2500EX - LU3000EX - GENOS L300MW /MYW

MODULO MOTORIZZATO ASSIALE ARRETRATO
 Axial rear-set driven tool
 Axial angetriebenes Werkzeug zurueckversetzt

Subject to change without notice.

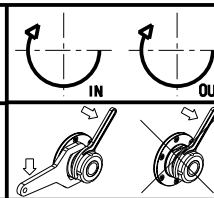

M.T. srl
 Via Casino Albini 480
 Tel. 0541/956034-957884
 Fax 0541/956341
 47842 S. GIOVANNI IN M. (RN)
 e-mail: mtma@mtmarchetti.com
 http://www.mtmarchetti.com

PRODUZIONE MODULI ROTANTI



PAGINA OKU180-4-10

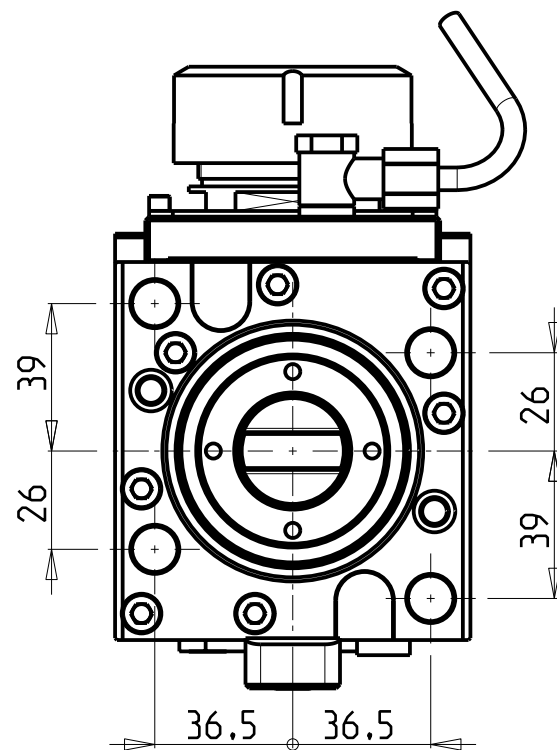
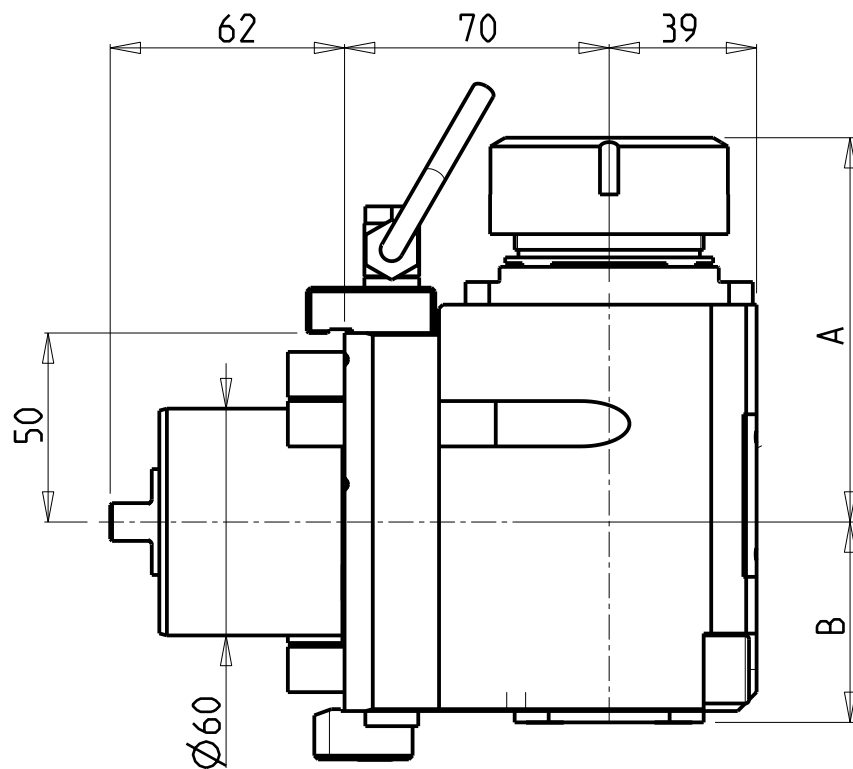

ATTENZIONE - ATTENTION - ACHTUNG

- Per lo smontaggio degli utensili utilizzare sempre la chiave di contrasto come indicato nel manuale d'uso.
- For disassembly of the tools use always the contrast key as mentioned in the user instructions.
- Fuer das Abmontieren der Werkzeuge immer den Gegenschlüssel benutzen wie in der Bedienungsanleitung erwäehnt.

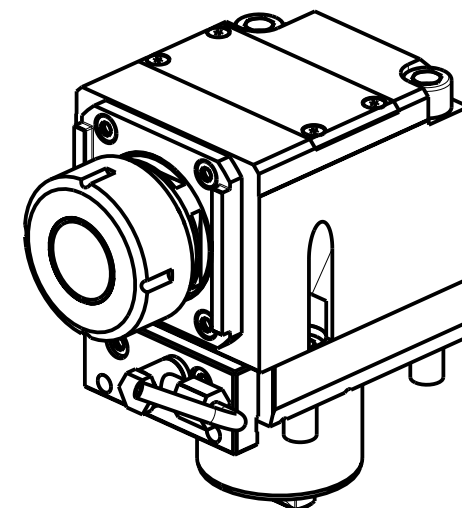

Cod. MT	Mandrino Spindle Spindel	I	RPM	Coppia Max Max Torque Max Drehmoment	Reversibile lato mandrino/contromandrino Reversible sub/main spindle side Umkehrbare Spindel-seite/ Gegenspindel-seite	Lubrificazione int. Coolant through Innenkuehlung	Lubrificazione est. Ext. coolant Aussenkuehlung	A	B	CHIAVI NON INCLUSE Keys not included Schlüssel nicht einbegriffen	
OKU0320132	ER32	2:1	3000	90Nm	X	-	X	98.7	53	CHSTER32	OKU0650004
OKU0320232	ER32	2:1	3000	90Nm	X	P=70bar	X	98.7	64	CHSTER32	OKU0650004
OKU0320140	ER40	2:1	3000	90Nm	X	-	X	101.7	53	CHSTER40	OKU0650004
OKU0320240	ER40	2:1	3000	90Nm	X	P=70bar	X	101.7	64	CHSTER40	OKU0650004

- Chiave inclusa
- Key included
- Schlüssel inbegriffen

OKUMA
 MOD: LB2000EX - LB2500EX - LB3000EX - LU2000EX - LU2500EX - LU3000EX - GENOS L300MW /MYW - GENOS L3000M

MODULO MOTORIZZATO ASSIALE RIDOTTO I=2:1
 Axial geared-down I=2:1 driven tool
 Axial angetriebenes Werkzeug untersetzt I=2:1

Subject to change without notice.

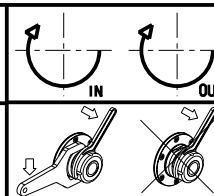

M.T. srl
 Via Casino Albini 480
 Tel. 0541/956034-957884
 Fax 0541/956341
 47842 S. GIOVANNI IN M. (RN)
 e-mail: mtma@mtmarchetti.com
 http://www.mtmarchetti.com

PRODUZIONE MODULI ROTANTI



PAGINA OKU190-4-10

ATTENZIONE - ATTENTION - ACHTUNG

- Per lo smontaggio degli utensili utilizzare sempre la chiave di contrasto come indicato nel manuale d'uso.
- For disassembly of the tools use always the contrast key as mentioned in the user instructions.
- Fuer das Abmontieren der Werkzeuge immer den Gegenschlüssel benutzen wie in der Bedienungsanleitung erwaeht.

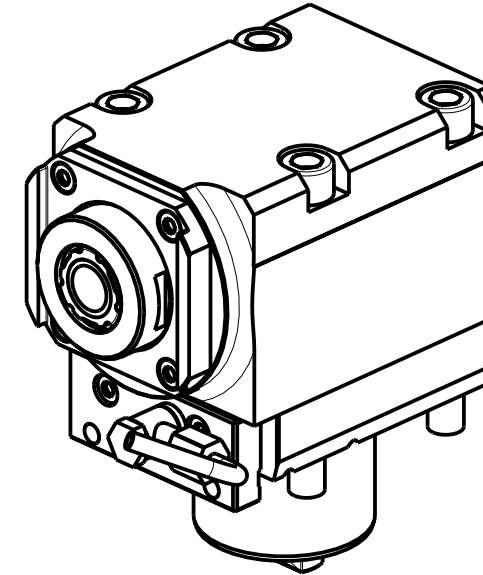
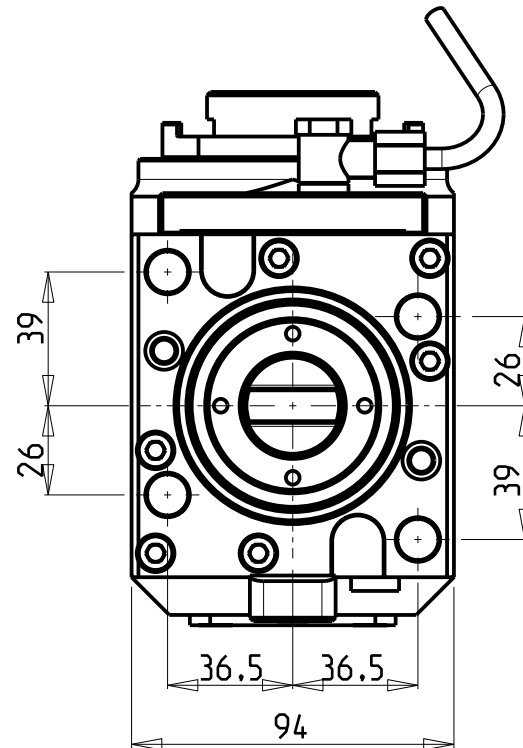
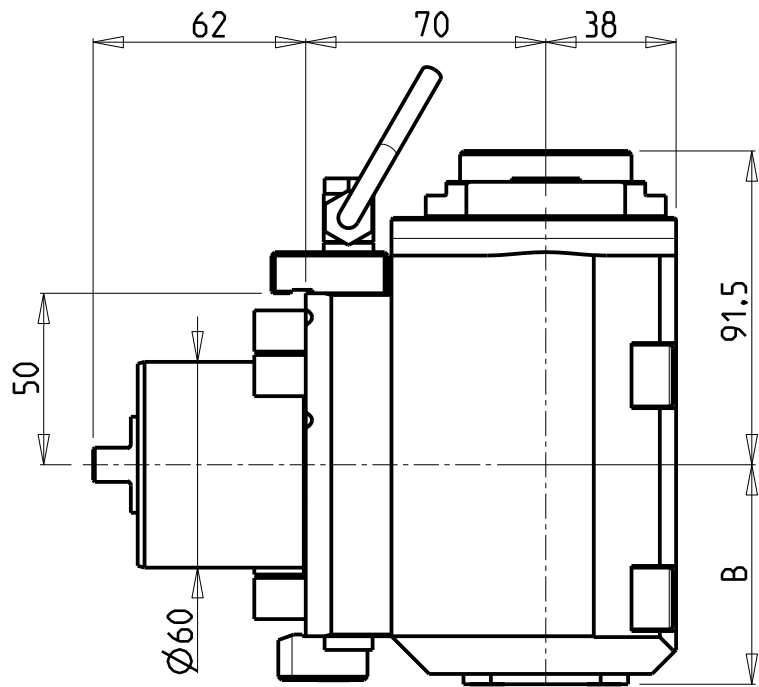

- Chiave inclusa
- Key included
- Schlüssel inbegriffen

Cod. MT	Mandrino Spindle Spindel	I	RPM	Coppia Max Max Torque Max Drehmoment	Reversibile lato mandrino/contromandrino Reversible sub/main spindle side Umkehrbare Spindel-seite/ Gegenspindel-seite	Lubrificazione int. Coolant through Innenkuehlung	Lubrificazione est. Ext. coolant Aussenkuehlung	B	CHIAVI NON INCLUSE Keys not included Schlüssel nicht inbegriffen		
OKU0330325	ERA25	1:2	12000	50Nm	X		X	64	CHUB27	CHTAER25ZC	OKU0650004
OKU0330425	ERA25	1:2	12000	50Nm	X	P=70bar	X	74	CHUB27	CHTAER25ZC	OKU0650004

OKUMA
 MOD: LB2000EX - LB2500EX - LB3000EX - LU2000EX - LU2500EX - LU3000EX - GENOS L300MW /MYW - GENOS L3000M

MODULO MOTORIZZATO ASSIALE MOLTIPLICATO I=1:2
 Axial geared-up I=1:2 driven tool
 Axial angetriebenes Werkzeug uebersetzt I=1:2

Subject to change without notice.

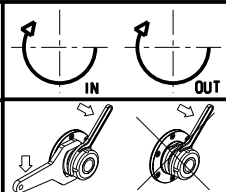

M.T. srl
 Via Casino Albini 480
 Tel. 0541/956034-957884
 Fax 0541/956341
 47842 S. GIOVANNI IN M. (RN)
 e-mail: mtma@mtmarchetti.com
 http://www.mtmarchetti.com

PRODUZIONE MODULI ROTANTI



PAGINA OKU200-4-10

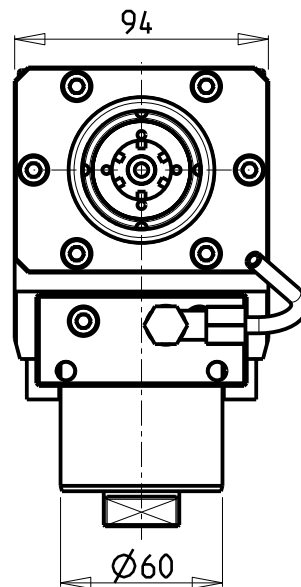
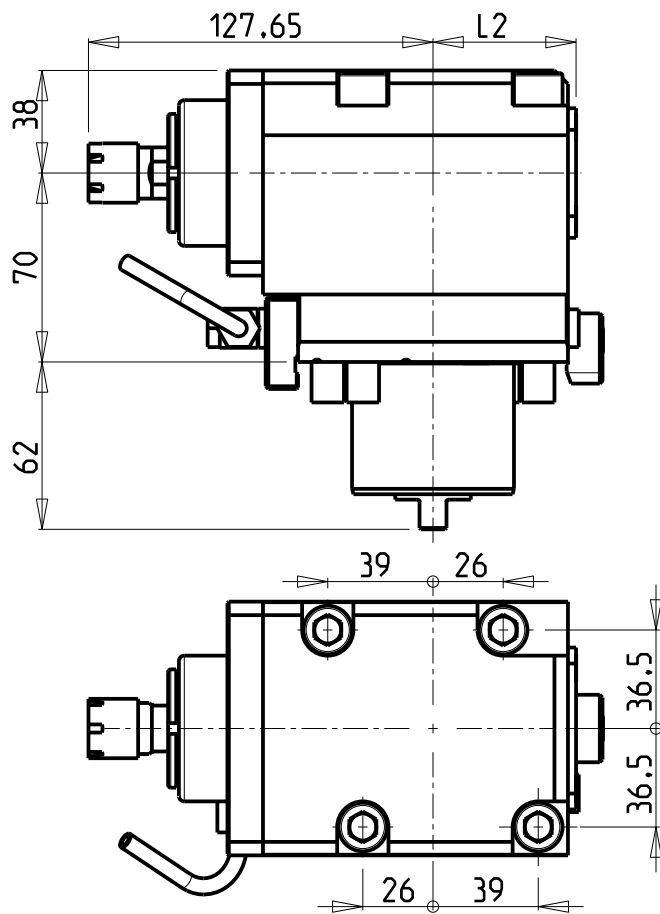

ATTENZIONE - ATTENTION - ACHTUNG

- Per lo smontaggio degli utensili utilizzare sempre la chiave di contrasto come indicato nel manuale d'uso.
- For disassembly of the tools use always the contrast key as mentioned in the user instructions.
- Fuer das Abmontieren der Werkzeuge immer den Gegenschlüssel benutzen wie in der Bedienungsanleitung erwaeht.

ATTENZIONE - ATTENTION - ACHTUNG

- PRIMA DI UTILIZZARE IL MOTORIZZATO CONSULTARE LE ISTRUZIONI ALLEGATE!
- BEFORE USING THE DRIVEN TOOL, PLEASE CHECK THE ENCLOSED INSTRUCTION SHEET!
- VOR DER BENUTZUNG DES ANGETRIEBENEN WERKZEUGES, DIE BEILIEGENDEN INSTRUKTIONEN DURCHLESEN!

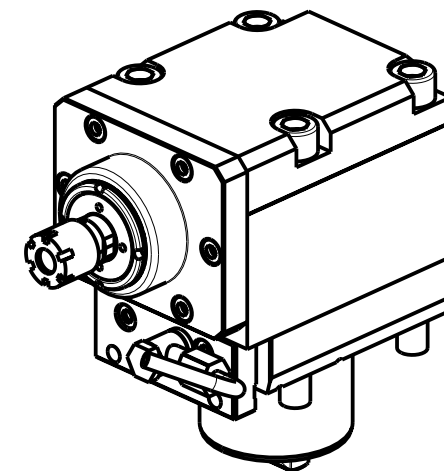

Cod. MT	Mandrino Spindle Spindel	I	RPM	Coppia Max Max Torque Max Drehmoment	Reversibile lato mandrino/contromandrino Reversible sub/main spindle side Umkehrbare Spindel-seite/ Gegenspindel-seite	Lubr.interna Coolant through Innenkuehlung	Lubrificazione est. Ext. coolant Ausseinkuehlung	L2	CHIAVI INCLUSE Keys included Schluessel einbegriffen	
OKU0410116	ER16	1:3	18000	10Nm	X		X	53	CHUB17	CHMNER16
OKU0410216	ER16	1:3	18000	10Nm	X	P=70bar	X	63	CHUB17	CHMNER16

OKUMA
 MOD: LB2000EX - LB2500EX - LB3000EX - LU2000EX - LU2500EX - LU3000EX - GENOS L300MW /MYW - GENOS L3000M

MODULO MOTORIZZATO ASSIALE MOLTIPLICATO I=1:3
 Axial geared-up I=1:3 driven tool
 Axial angetriebenes Werkzeug uebersetzt I=1:3

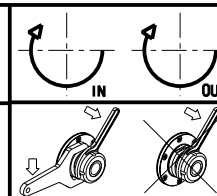

M.T. srl
 Via Casino Albini 480
 Tel. 0541/956034-957884
 Fax 0541/956341
 47842 S. GIOVANNI IN M. (RN)
 e-mail: mtma@mtmarchetti.com
 http://www.mtmarchetti.com

PRODUZIONE MODULI ROTANTI



PAGINA OKU205-4-10

Subject to change without notice.

10/2018

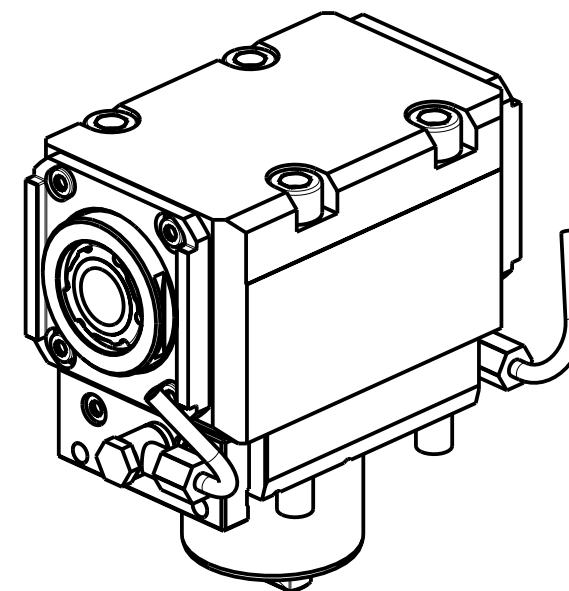
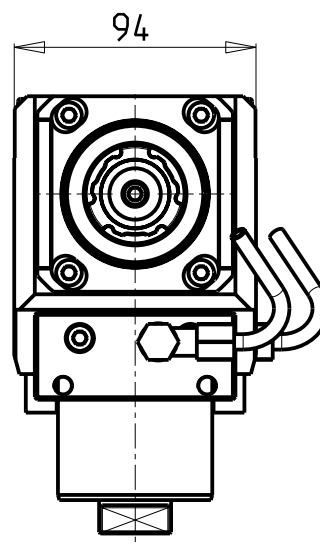
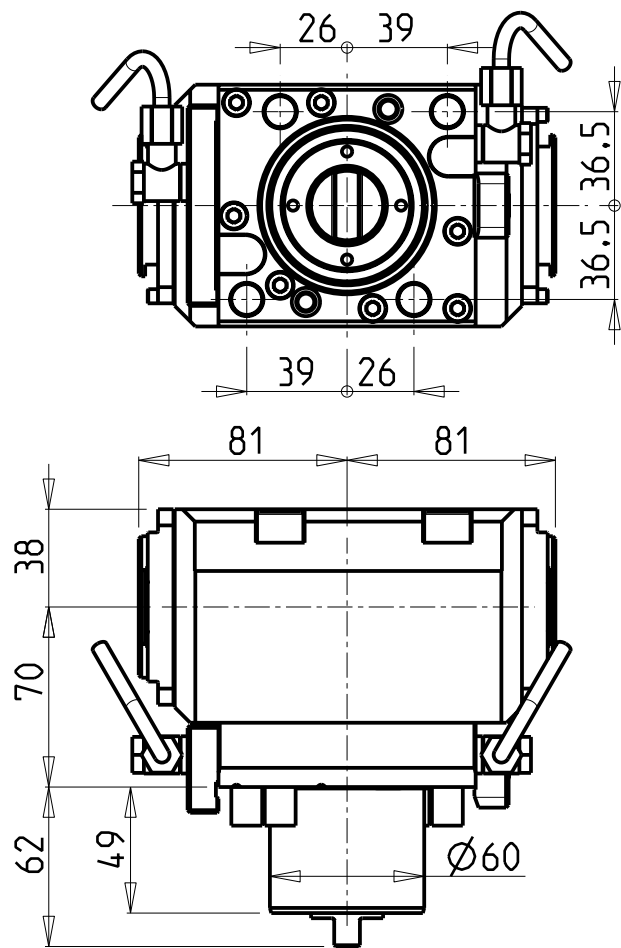

ATTENZIONE - ATTENTION - ACHTUNG

- Per lo smontaggio degli utensili utilizzare sempre la chiave di contrasto come indicato nel manuale d'uso.
- For disassembly of the tools use always the contrast key as mentioned in the user instructions.
- Fuer das Abmontieren der Werkzeuge immer den Gegenschlüssel benutzen wie in der Bedienungsanleitung erwaeht.

- Chiave inclusa
- Key included
- Schluessel inbegriffen

Cod. MT	Mandrino Spindle Spindel	I	RPM	Coppia Max Max Torque Max Drehmoment	Reversibile lato mandrino/contromandrino Reversible sub/main spindle side Umkehrbare Spindel-seite/ Gegenspindel-seite	Lubr.esterna Ext. coolant Aussenkuehlung	CHIAVI NON INCLUDE Keys not included Schluessel nicht einbegriffen	
OKU0800232	ERA32+ERA32	1:1	6000	70Nm	X	X	CHUB30	CHTAER32ZC • OKU0650004 •

OKUMA
 MOD: LB2000EX - LB2500EX - LB3000EX - LU2000EX - LU2500EX - LU3000EX - GENOS L300MW /MYW

MODULO MOTORIZZATO ASSIALE BISPORGENTE H=70mm
 Axial opposite face twin driven tool H=70mm
 Axial angetriebenes Werkzeug halb vorspringend H=70mm

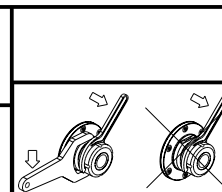

M.T. srl
 Via Casino Albini 480
 Tel. 0541/956034-957884
 Fax 0541/956341
 47842 S. GIOVANNI IN M. (RN)
 e-mail: mtma@mtmarchetti.com
 http://www.mtmarchetti.com

PRODUZIONE MODULI ROTANTI



PAGINA OKU240-4-10

Subject to change without notice.

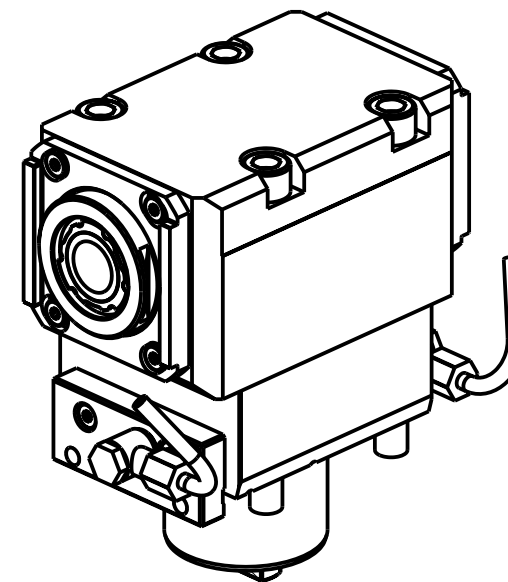
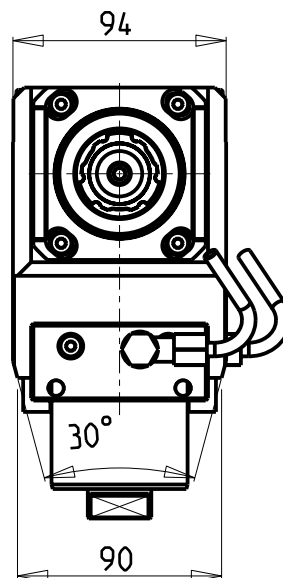
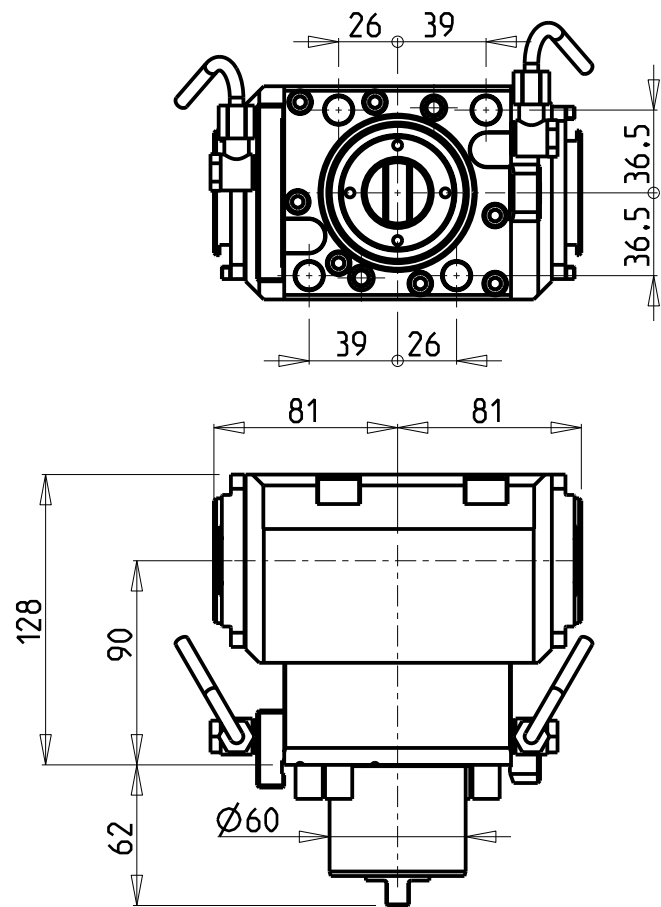

ATTENZIONE - ATTENTION - ACHTUNG

- Per lo smontaggio degli utensili utilizzare sempre la chiave di contrasto come indicato nel manuale d'uso.
- For disassembly of the tools use always the contrast key as mentioned in the user instructions.
- Fuer das Abmontieren der Werkzeuge immer den Gegenschlüssel benutzen wie in der Bedienungsanleitung erwaeht.

- Chiave inclusa
- Key included
- Schluessel inbegriffen

Cod. MT	Mandrino Spindle Spindel	I	RPM	Coppia Max Max Torque Max Drehmoment	Reversibile lato mandrino/contromandrino Reversible sub/main spindle side Umkehrbare Spindelseite/ Gegenspindelsteite	Lubr.esterna Ext. coolant Aussenkuehlung	CHIAVI NON INCLUDE Keys not included Schluessel nicht einbegriffen			
OKU1660232	ERA32+ERA32	1:1	6000	70Nm	X	X	CHUB30	CHTAER32ZC	OKU0650004	NEW

OKUMA

MOD: MULTUS U3000/4000 2SW - GENOS L300MW/MYW

MODULO MOTORIZZATO ASSIALE BISPORGENTE H=90mm

Axial opposite face twin driven tool H=90mm

Axial angetriebenes Werkzeug halb vorspringend H=90mm

Subject to change without notice.

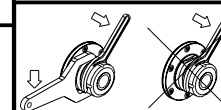

M.T. srl
Via Casino Albini 480
Tel. 0541/956034-957884
Fax 0541/956341
47842 S. GIOVANNI IN M. (RN)
e-mail: mtma@mtmarchetti.com
http://www.mtmarchetti.com

PRODUZIONE MODULI ROTANTI



PAGINA OKU240-4-20

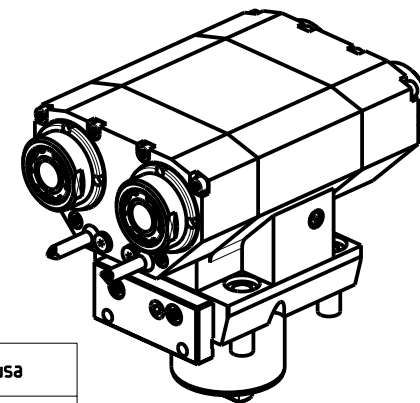
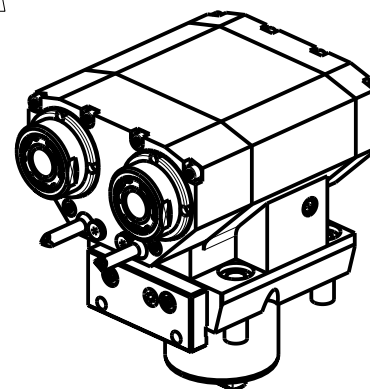
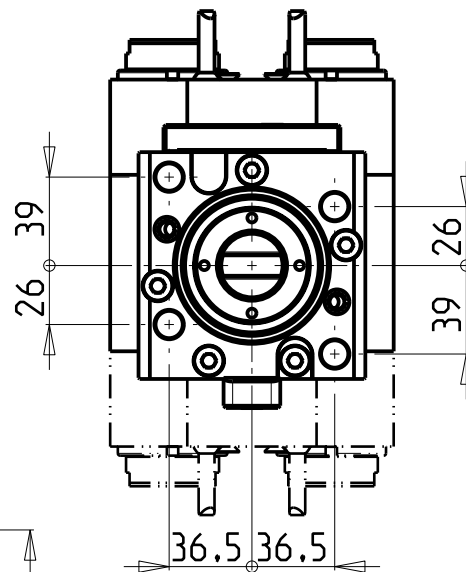
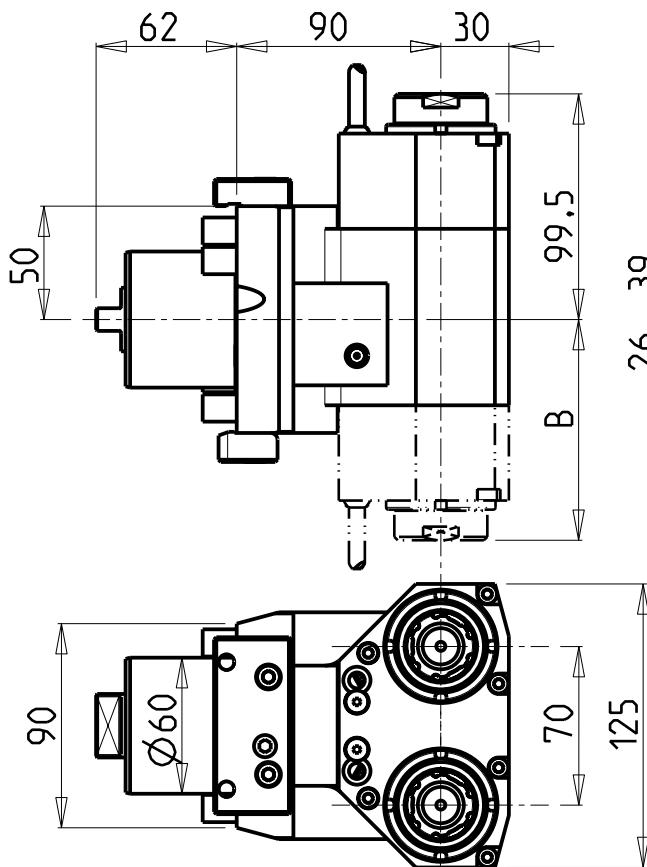

ATTENZIONE - ATTENTION - ACHTUNG

- Per lo smontaggio degli utensili utilizzare sempre la chiave di contrasto come indicato nel manuale d'uso.
- For disassembly of the tools use always the contrast key as mentioned in the user instructions.
- Fuer das Abmontieren der Werkzeuge immer den Gegenschlüssel benutzen wie in der Bedienungsanleitung erwaeht.

- Chiave inclusa
- Key included
- Schluessel inbegriffen

Cod. MT	Mandrino Spindle Spindel	I	RPM	Coppia Max Max Torque Max Drehmoment	N°Utensili N°Tools N°Werkzeuge	Reversibile lato mandrino/contromandrino Reversible sub/main spindle side Umkehrbare Spindelsete/Gegenspindelsete	Lubrificazione int. Coolant through Innenkuehlung	Lubr.esterna Ext. coolant Aussenkuehlung	B	CHIAVI NON INCLUDE Keys not included Schluessel nicht einbegriffen		
OKU0300125	ERA25	1:1	6000	50Nm	2	X		X	56.8	CHUB38	CHUB27	CHTAER25ZC •
OKU0301125	ERA25+ERA25	1:1	6000	50Nm	2+2	X		X	97.3	CHUB38	CHUB27	CHTAER25ZC •
OKU0300225	ERA25	1:1	6000	50Nm	2	X	P=70bar	X	56.8	CHUB38	CHUB27	CHTAER25ZC •
OKU0301225	ERA25+ERA25	1:1	6000	50Nm	2+2	X	P=70bar	X	97.3	CHUB38	CHUB27	CHTAER25ZC •

OKUMA
 MOD: LB2000EX - LB2500EX - LB3000EX - LU2000EX - LU2500EX - LU3000EX - GENOS L300MW /MYW

MODULO MOTORIZZATO ASSIALE 2/4 USCITE IN Y
 Axial multiple 2/4 outlet driven tool in Y
 Axial angetriebenes Mehrspindel-Werkzeug 2/4 Ausgaenge in Y

Subject to change without notice.

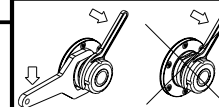

M.T. srl

Via Casino Albini 480
 Tel. 0541/956034-957884
 Fax 0541/956341
 47842 S. GIOVANNI IN M. (RN)
 e-mail: mtma@mtmarchetti.com
 http://www.mtmarchetti.com

PRODUZIONE MODULI ROTANTI



PAGINA OKU268-4-00

ATTENZIONE - ATTENTION - ACHTUNG

- Per lo smontaggio degli utensili utilizzare sempre la chiave di contrasto come indicato nel manuale d'uso.
- For disassembly of the tools use always the contrast key as mentioned in the user instructions.
- Fuer das Abmontieren der Werkzeuge immer den Gegenschlüssel benutzen wie in der Bedienungsanleitung erwaeht.

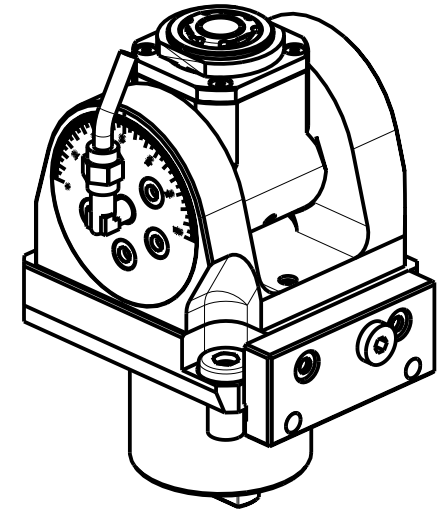
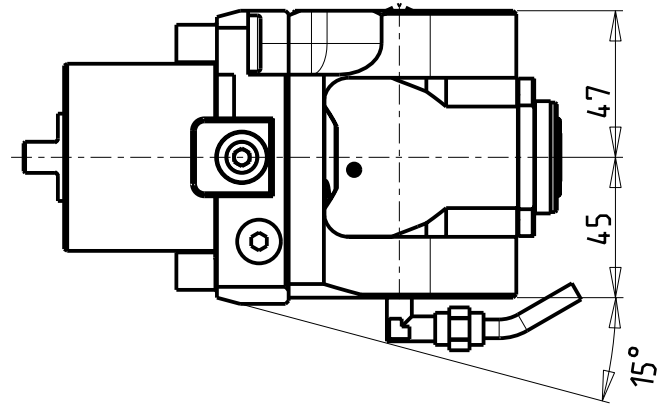
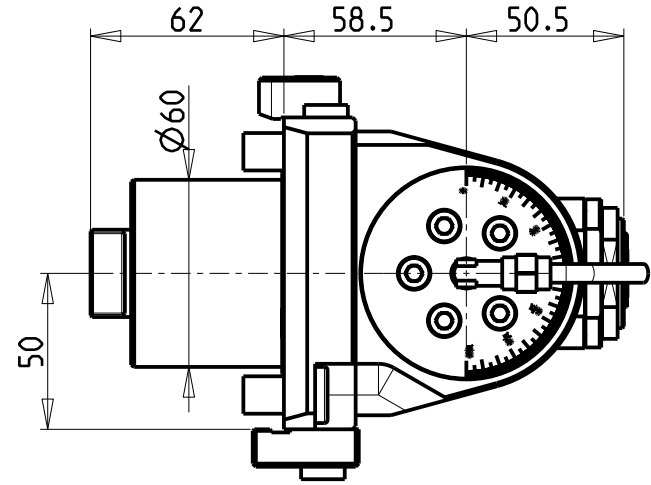
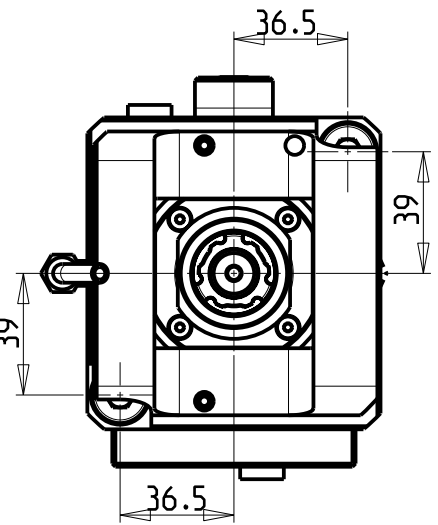

Cod. MT	Mandrino Spindle Spindel	I	RPM	Coppia Max Max Torque Max Drehmoment	Lubrificazione int. Coolant through Innenkuehlung	Lubrificazione est. Ext. coolant Aussenkuehlung	CHIAVI INCLUSE Keys included Schluesssel inbegriffen			
OKU0080120	ERA20	1:1	6000	30Nm		X	CHUB36	CHUB22	CHTAER20ZC	CHESL08
OKU0080220	ERA20	1:1	6000	30Nm	P=70bar	X	CHUB36	CHUB22	CHTAER20ZC	CHESL08

OKUMA
 MOD: LB2000EX - LB2500EX - LB3000EX - LU2000EX - LU2500EX - LU3000EX - GENOS L300MW/MYW - GENOS L3000M

MODULO MOTORIZZATO ORIENTABILE +/-90°
 +/-90° adjustable angle driven tool
 Angetriebenes Werkzeug schwenkbar +/-90°

Subject to change without notice.

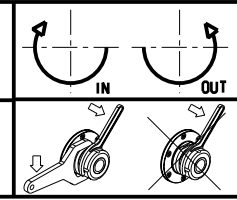

M.T. srl
 Via Casino Albini 480
 Tel. 0541/956034-957884
 Fax 0541/956341
 47842 S. GIOVANNI IN M. (RN)
 e-mail: mtma@mtmarchetti.com
 http://www.mtmarchetti.com

PRODUZIONE MODULI ROTANTI



PAGINA OKU335-4-00

ATTENZIONE - ATTENTION - ACHTUNG

- Per lo smontaggio degli utensili utilizzare sempre la chiave di contrasto come indicato nel manuale d'uso.
- For disassembly of the tools use always the contrast key as mentioned in the user instructions.
- Fuer das Abmontieren der Werkzeuge immer den Gegenschlüssel benutzen wie in der Bedienungsanleitung erwaeht.

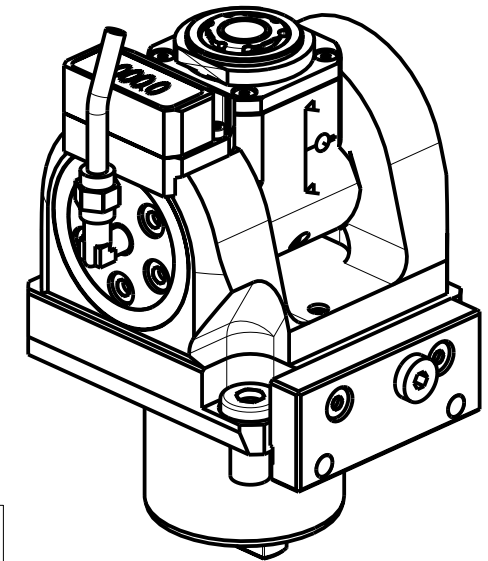
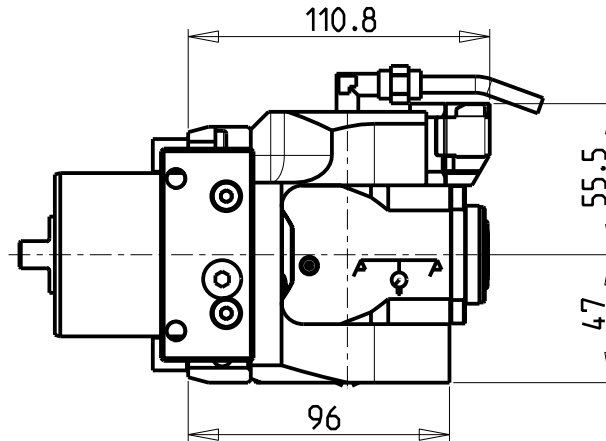
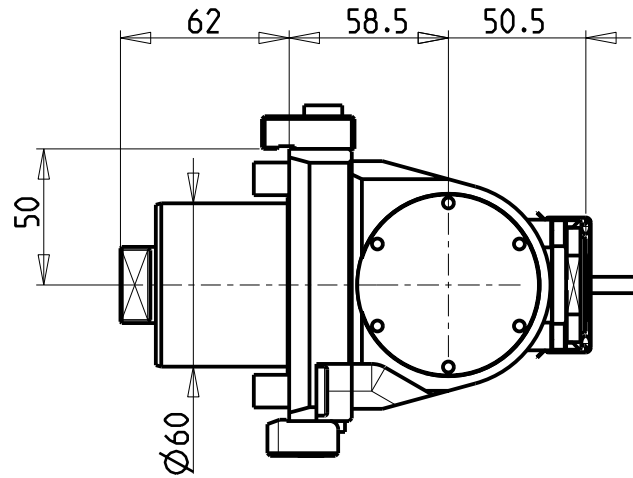
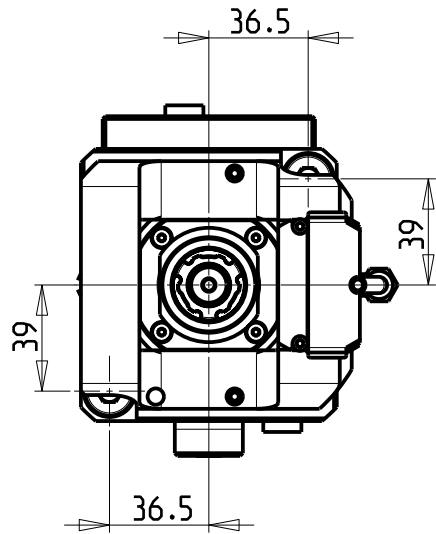

Cod. MT	Mandrino Spindle Spindel	I	RPM	Coppia Max Max Torque Max Drehmoment	Lubrificazione int. Coolant through Innenkuehlung	Lubrificazione est. Ext. coolant Aussenkuehlung	CHIAVI INCLUSE Keys included Schluesssel inbegriffen			
OKU0085120	ERA20	1:1	6000	30Nm	-	X	CHUB36	CHUB22	CHTAER20ZC	CHESL08
OKU0085220	ERA20	1:1	6000	30Nm	P=70bar	X	CHUB36	CHUB22	CHTAER20ZC	CHESL08

OKUMA
 MOD: LB2000EX - LB2500EX - LB3000EX - LU2000EX - LU2500EX - LU3000EX - GENOS L300MW /MYW - GENOS L3000M

MODULO MOTORIZZATO ORIENTABILE ±90° CON NONIO DIGITALE
 ±90° adjustable angle driven tool with digital display
 Angetriebenes Werkzeug schwenkbar ±90° mit digital display

Subject to change without notice.

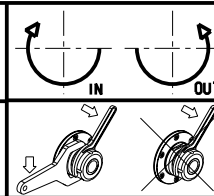

M.T. srl
 Via Casino Albini 480
 Tel. 0541/956034-957884
 Fax 0541/956341
 47842 S. GIOVANNI IN M. (RN)
 e-mail: mtma@mtmarchetti.com
 http://www.mtmarchetti.com

PRODUZIONE MODULI ROTANTI

PAGINA OKU335-4-01

ATTENZIONE - ATTENTION - ACHTUNG

- Per lo smontaggio degli utensili utilizzare sempre la chiave di contrasto come indicato nel manuale d'uso.
- For disassembly of the tools use always the contrast key as mentioned in the user instructions.
- Fuer das Abmontieren der Werkzeuge immer den Gegenschlüssel benutzen wie in der Bedienungsanleitung erwaeht.

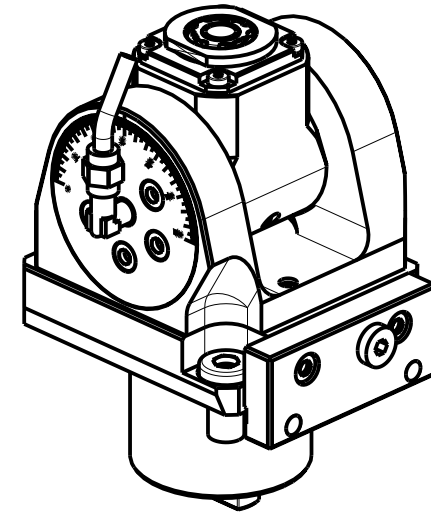
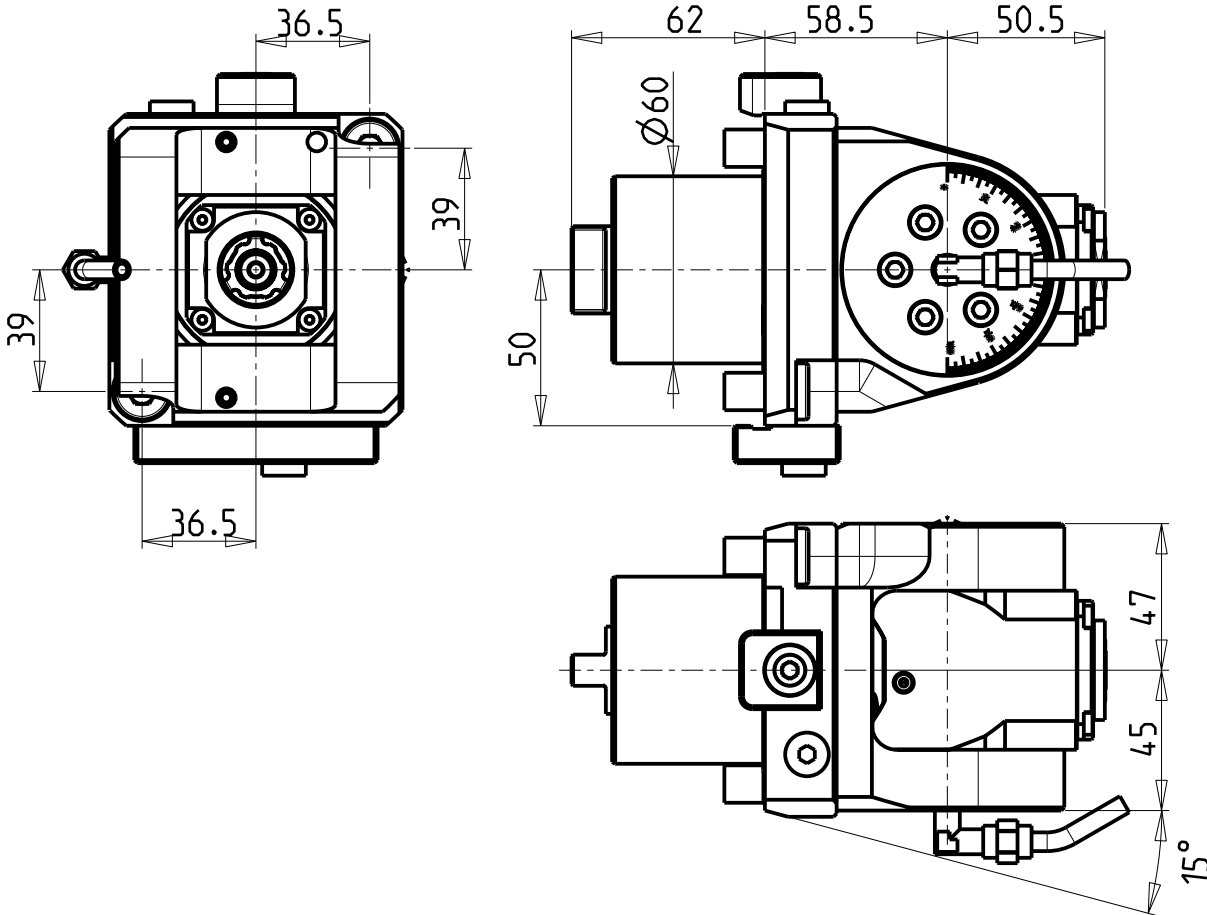

Cod. MT	Mandrino Spindle Spindel	I	RPM	Coppia Max Max Torque Max Drehmoment	Lubrificazione int. Coolant through Innenkuehlung	Lubrificazione est. Ext. coolant Aussenkuehlung	CHIAVI INCLUSE Keys included Schluesssel inbegriffen			
							C HUB19_SP3	C HUB32	C HTAER16ZC	C HESL08
OKU0080316	ERA16	1:2	12000	8Nm		X	C HUB19_SP3	C HUB32	C HTAER16ZC	C HESL08
OKU0080416	ERA16	1:2	12000	8Nm	P=70bar	X	C HUB19_SP3	C HUB32	C HTAER16ZC	C HESL08

OKUMA
 MOD: LB2000EX - LB2500EX - LB3000EX - LU2000EX - LU2500EX - LU3000EX - GENOS L300MW/MYW - GENOS L3000M

MODULO MOTORIZZATO ORIENTABILE +/-90° MOLTIPLICATO I=1:2
 +/-90° adjustable angle driven tool Geared-up I=1:2
 Angetriebenes Werkzeug schwenkbar +/-90° uebersetzt I=1:2

Subject to change without notice.

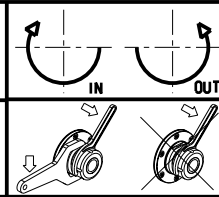

M.T. srl
 Via Casino Albini 480
 Tel. 0541/956034-957884
 Fax 0541/956341
 47842 S. GIOVANNI IN M. (RN)
 e-mail: mtma@mtmarchetti.com
 http://www.mtmarchetti.com

PRODUZIONE MODULI ROTANTI



PAGINA OKU336-4-00

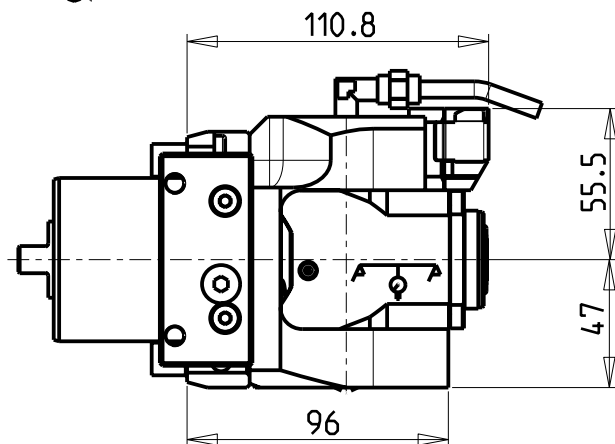
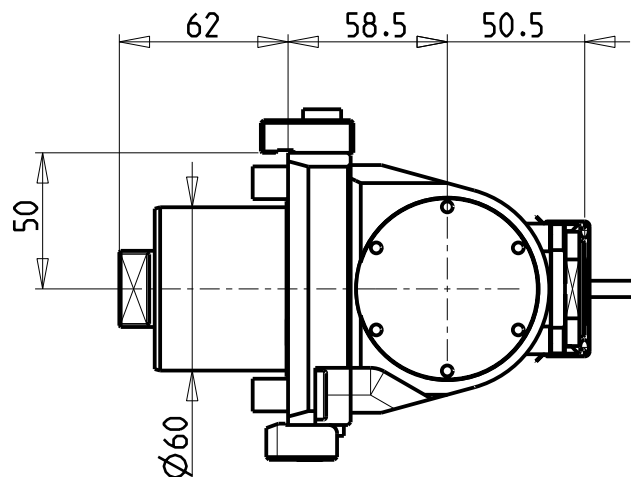
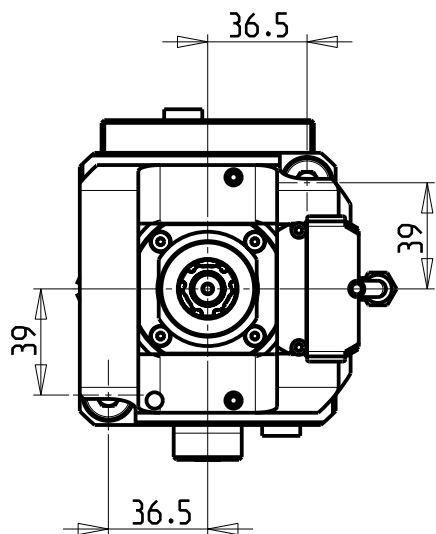

ATTENZIONE - ATTENTION - ACHTUNG

- Per lo smontaggio degli utensili utilizzare sempre la chiave di contrasto come indicato nel manuale d'uso.
- For disassembly of the tools use always the contrast key as mentioned in the user instructions.
- Fuer das Abmontieren der Werkzeuge immer den Gegenschlüssel benutzen wie in der Bedienungsanleitung erwaeht.

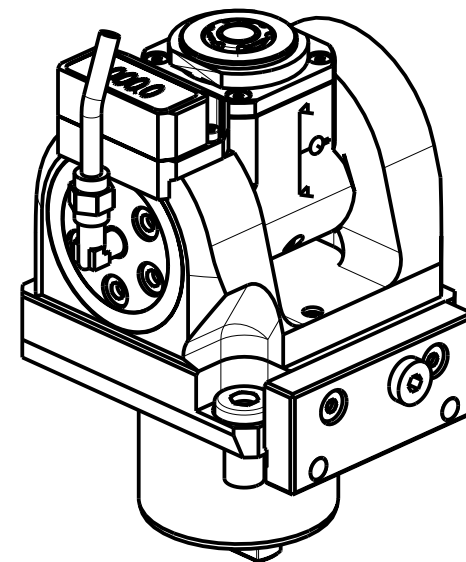

Cod. MT	Mandrino Spindle Spindel	I	RPM	Coppia Max Max Torque Max Drehmoment	Lubrificazione int. Coolant through Innenkuehlung	Lubrificazione est. Ext. coolant Aussenkuehlung	CHIAVI INCLUSE Keys included Schluessel inbegriffen			
OKU0085316	ERA16	1:2	12000	8Nm	-	X	CHUB19_SP3	CHUB32	CHTAER16ZC	CHESL08
OKU0085416	ERA16	1:2	12000	8Nm	P=70bar	X	CHUB19_SP3	CHUB32	CHTAER16ZC	CHESL08

OKUMA
 MOD: LB2000EX - LB2500EX - LB3000EX - LU2000EX - LU2500EX - LU3000EX - GENOS L300MW/MYW - GENOS L3000M

MODULO MOTORIZZATO ORIENTABILE +/-90° MOLTIPLICATO I=1:2 CON NONIO DIGITALE
 +/-90° adjustable angle driven tool Geared-up I=1:2 with digital display
 Angetriebenes Werkzeug schwenkbar +/-90° uebersetzt I=1:2 mit digital display

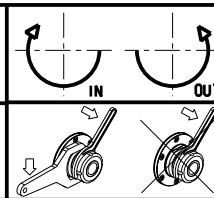

M.T. srl
 Via Casino Albini 480
 Tel. 0541/956034-957884
 Fax 0541/956341
 47842 S. GIOVANNI IN M. (RN)
 e-mail: mtma@mtmarchetti.com
 http://www.mtmarchetti.com

PRODUZIONE MODULI ROTANTI



PAGINA OKU336-4-01

Subject to change without notice.

10/2018

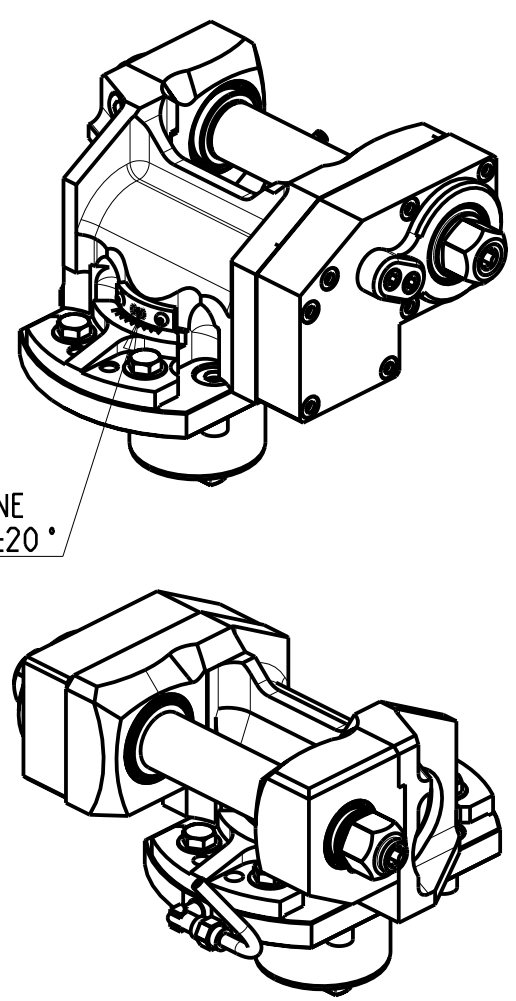
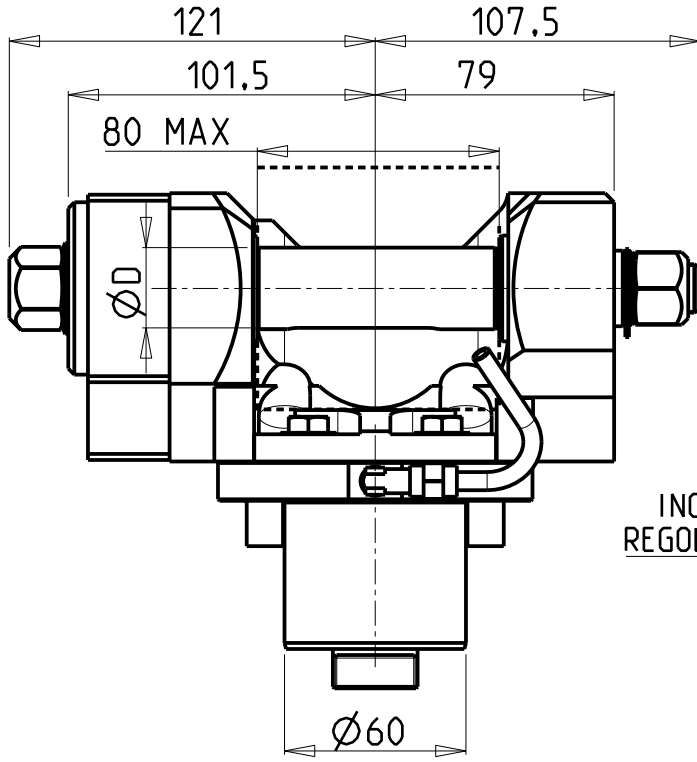
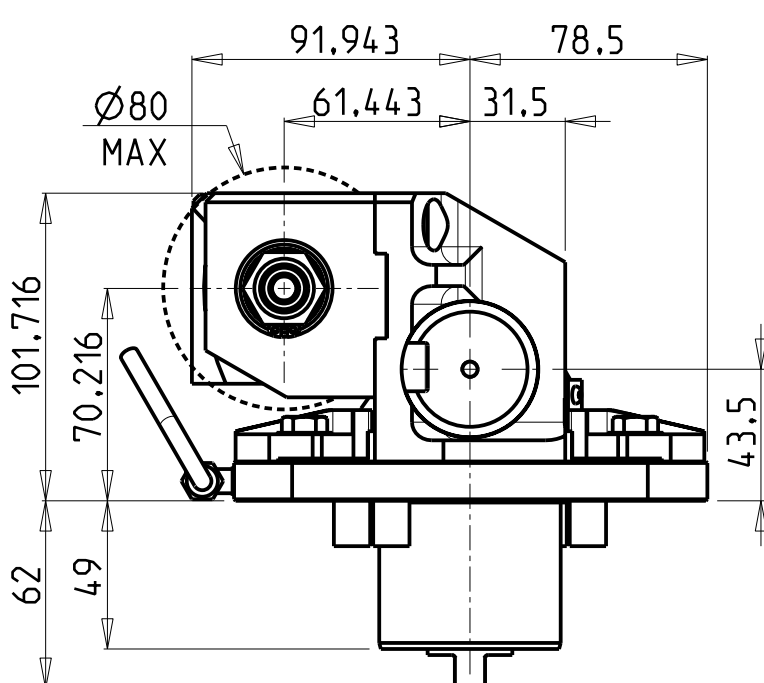

INCLINAZIONE
REGOLABILE ±20°

DOTAZIONI - SUPPLIED WITH - AUSSTATTUNG

- mm / inch - N°1 ALBERO + DISTANZIALI
- N°1 SHAFT + SPACER
- N°1 DORN + ABSTANDSSTUECK

PER ALBERI E DISTANZIALI VEDI PAG. TBL250-1-00
 FOR SHAFT END SPACER SEE PAGE TBL250-1-00
 FUER DORN UND ABSTANDSSTUECK SEITE TBL250-1-00

Cod. MT	I	RPM MAX	Coppia Max Max Torque Max Drehmoment	Reversibile lato mandrino/contromandrino	Lubr. esterna Ext. coolant Aussenkuehlung	D (mm)	D (Inch)	CHIAVI INCLUSE Keys included Schlüssel inbegriffen		
				Reversible sub/main spindle side Umkehrbare Spindel-seite/ Gegenspindel-seite				C HUB13	C HUB24	C HESL08
OKU0251100	1:1	6000	60Nm	X	X	16-22-27-32	3/4"-1"-1 1/4"	C HUB13	C HUB24	C HESL08
OKU0252100	2:1	3000	80Nm	X	X	16-22-27-32	3/4"-1"-1 1/4"	C HUB13	C HUB24	C HESL08

OKUMA
 MOD: LB2000EX - LB2500EX - LB3000EX - LU2000EX - LU2500EX - LU3000EX - MULTUS U3000/4000 2SW
 GENOS L300MW/MYW

MODULO MOTORIZZATO PORTACREATORE
 Driven gear hobber
 Angetriebenes Zahnradwaeltzraes-Werkzeug

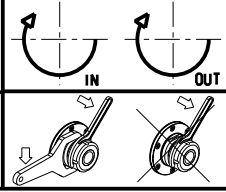

M.T. srl
 Via Casino Albini 480
 Tel. 0541/956034-957884
 Fax 0541/956341
 47842 S. GIOVANNI IN M. (RN)
 e-mail: mtma@mtmarchetti.com
 http://www.mtmarchetti.com

PRODUZIONE MODULI ROTANTI



PAGINA OKU340-4-00

Subject to change without notice.

10/2018

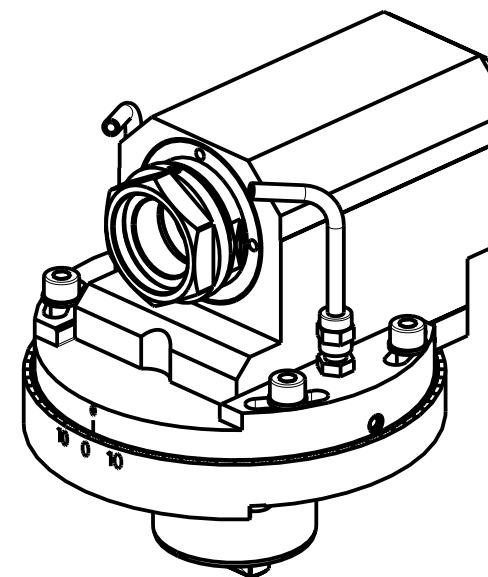
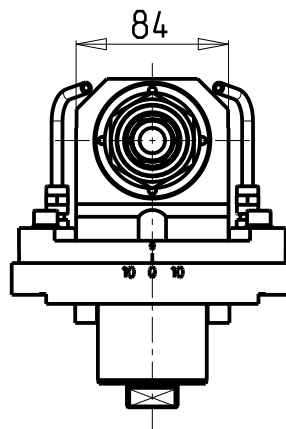
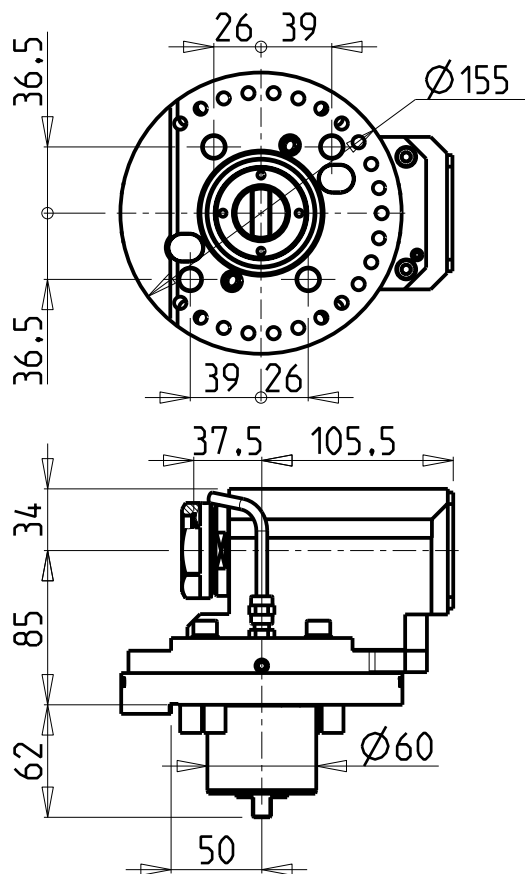

ATTENZIONE - ATTENTION - ACHTUNG

- VERIFICARE LE MISURE DI INGOMBRO PER POSSIBILE INTERFERENZA SU ALCUNI MODELLI DI MACCHINE
- Please check the overall sizes for possible interferences on some machine models
- Bitte überprüfen sie das ausmass um mögliche interferenzen auf einigen maschinen modellen zu vermeiden

PER PORTAUTENSILI MODULARI MTSK-40 VEDI PAG. TBL300-1-40
 FOR MTSK-40 QUICK CHANGE TOOLHOLDERS CLAMPINGS SEE PAGE TBL300-1-40
 FUER MTSK-40 MODULARE WERKZEUGAUFNAHMEN SIEHE SEITE TBL300-1-40

Cod. MT	Mandrino Spindle Spindel	I	RPM	Coppia Max Max Torque Max Drehmoment	Reversibile lato mandrino/contromandrino Reversible sub/main spindle side Umkehrbare Spindel-seite/Gegenspindel-seite	Lubr.esterna Ext. coolant Aussenkuehlung	CHIAVI INCLUSE Keys included Schluessel einbegriffen
OKU1420100	MTSK-40	1:1	6000	50Nm	X	X	n°2 CHUB46

OKUMA
 MOD: LB2000EX - LB2500EX - LB3000EX - LU2000EX - LU2500EX - LU3000EX - GENOS L300MW /MYW

MODULO MOTORIZZATO ASSIALE MTSK PER POWER SKIVING H=85mm
 Axial MTSK driven tool for Power Skiving H=85mm
 Axial MTSK angetriebenes Werkzeug fuer Power Skiving H=85mm

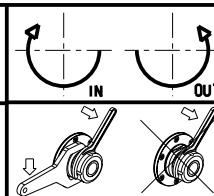

M.T. srl
 Via Casino Albini 480
 Tel. 0541/956034-957884
 Fax 0541/956341
 47842 S. GIOVANNI IN M. (RN)
 e-mail: mtma@mtmarchetti.com
 http://www.mtmarchetti.com

PRODUZIONE MODULI ROTANTI



PAGINA OKU350-4-00-K

Subject to change without notice.

10/2018

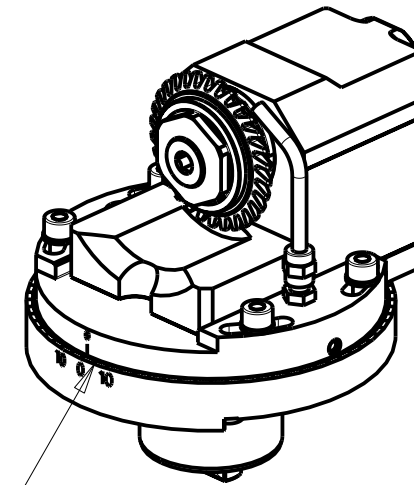
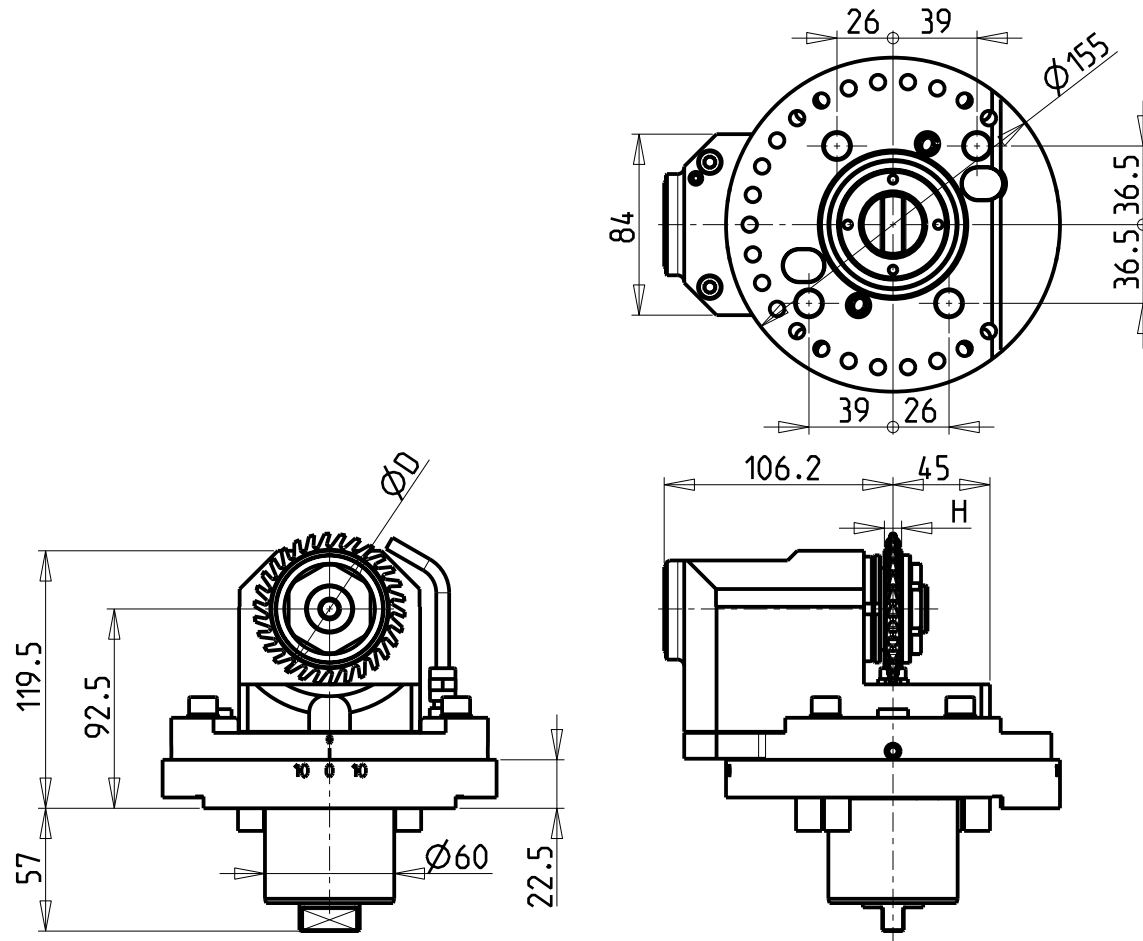

ORIENTABILE DI 360°

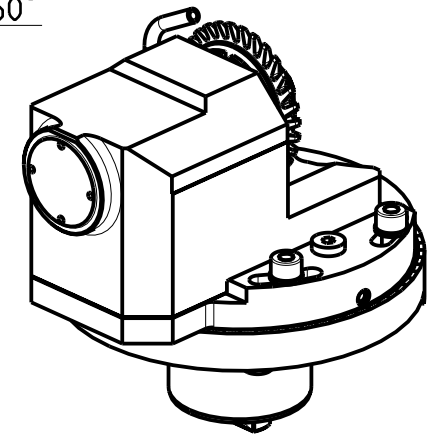

Cod. MT	Mandrino Spindel Spindel	I	RPM	Coppia Max Max Torque Max Drehmoment	Reversibile lato mandrino/contromandrino	Lubrificazione est. Ext. coolant Aussehenkuehlung	ØD	H	CHIAVI INCLUSE Keys included Schluesel einbegriffen		
					Reversible sub/main spindle side Umkehrbare Spindel-seite/ Gegenspindel-seite				CHUB38	CHESL08	CHESL10
OKU1468022	Ø22x12	1:1	6000	50Nm	X	X	63-70-80	MAX 12	CHUB38	CHESL08	CHESL10
OKU1468125	Ø1"x12	1:1	6000	50Nm	X	X	63-70-80	MAX 12	CHUB38	CHESL08	CHESL10

OKUMA
 MOD: LB2000EX - LB2500EX - LB3000EX - LU2000EX - LU2500EX - LU3000EX - MULTUS U3000/4000 2SW
 GENOS L300MW/MYW

MODULO MOTORIZZATO PER VITI SENZA FINE
 Driven tool for worm screws
 Angetriebenes Werkzeug für schrauben ohne ende

Subject to change without notice.

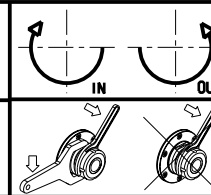

M.T. srl
 Via Casino Albini 480
 Tel. 0541/956034-957884
 Fax 0541/956341
 47842 S. GIOVANNI IN M. (RN)
 e-mail: mtma@mtmarchetti.com
 http://www.mtmarchetti.com

PRODUZIONE MODULI ROTANTI



PAGINA OKU359-4-00

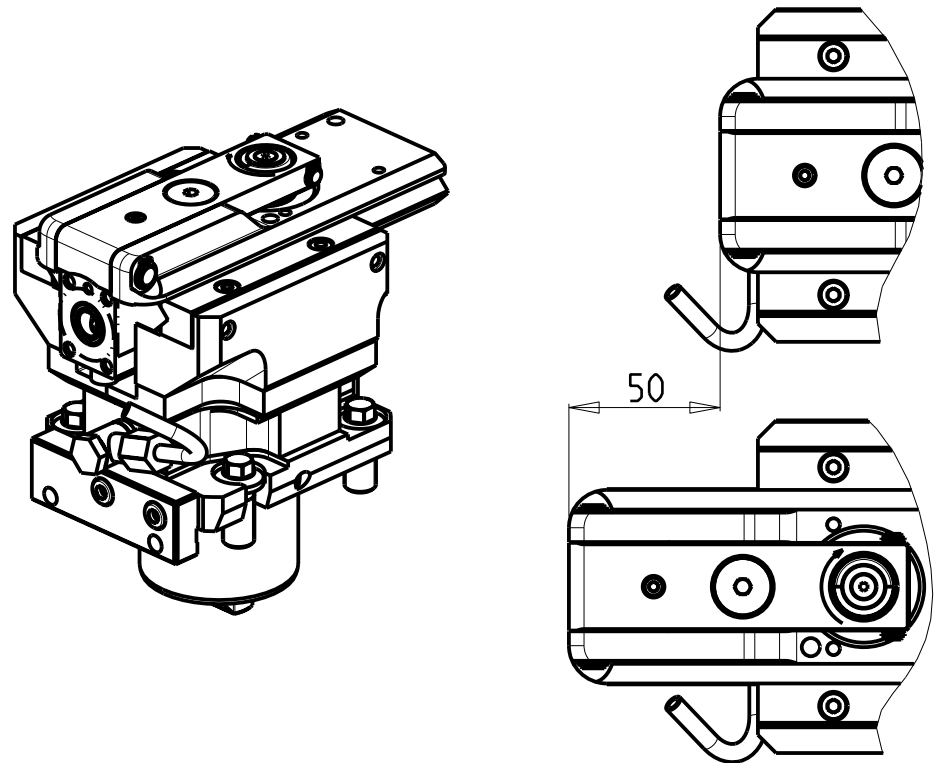
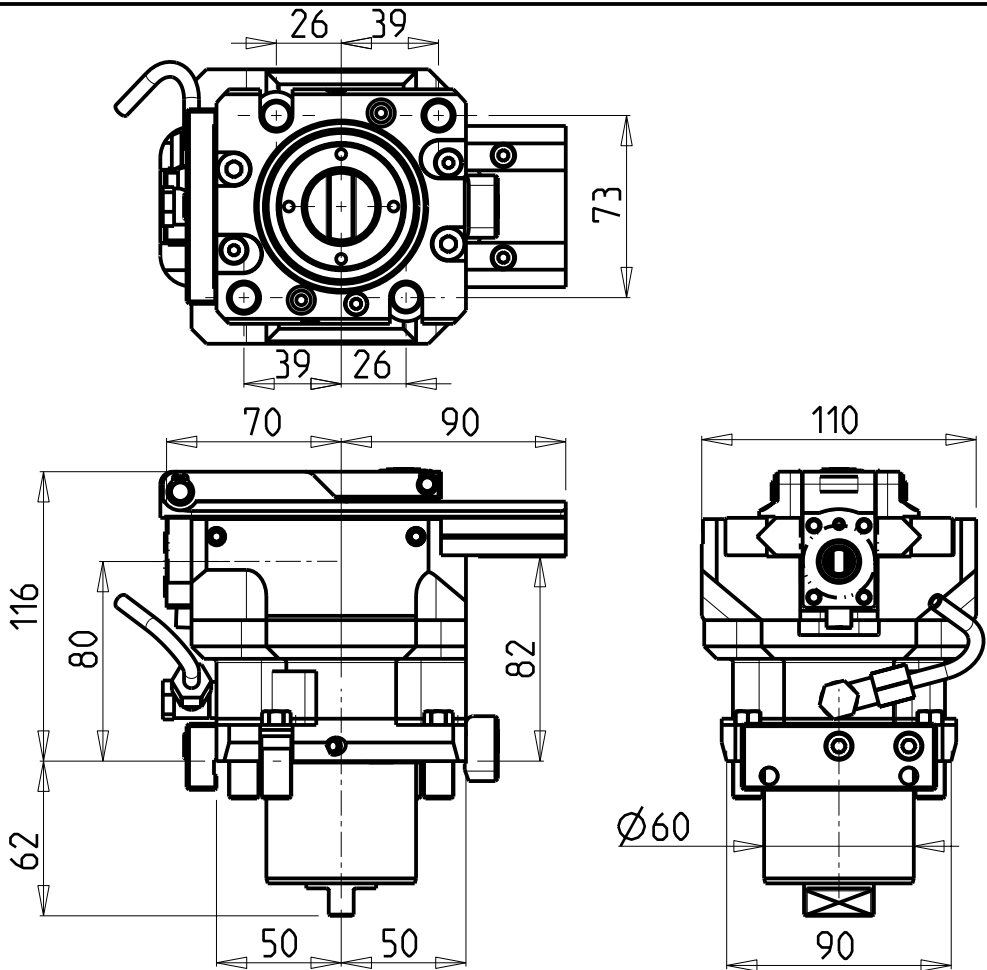

PER UTENSILI STOZZATORI VEDI PAG. TBL400-1-00
 FOR DRIVEN SLOTTING TOOL CUTTING-TOOLS SEE PAGE TBL400-1-00
 FÜR NUTENSTOSS-WERKZEUG SCHNEIDWERKZEUGE SIEHE SEITE TBL400-1-00

Cod. MT	I	RPM MAX	Reversibile lato mandrino/contromandrino Reversible sub/main spindle side Umkehrbare Spindelseite/ Gegenspindelseite	Lubr. esterna Ext. coolant Aussenkuehlung
OKU1160100	4:1	2000	X	X

OKUMA
 MOD: LB2000EX - LB2500EX - LB3000EX - LU2000EX - LU2500EX - LU3000EX - GENOS L300MW /MYW - GENOS L3000M
 MODULO MOTORIZZATO STOZZATORE CORSA 50mm H=80mm
 Slotting driven tool 50mm stroke H=80mm
 Keilnutenstossmaschine 50mm Hub H=80mm

M.T. srl
 Via Casino Albini 480
 Tel. 0541/956034-957884
 Fax 0541/956341
 47842 S. GIOVANNI IN M. (RN)
 e-mail: mtma@mtmarchetti.com
 http://www.mtmarchetti.com

PRODUZIONE MODULI ROTANTI

 PAGINA OKU360-4-00

Subject to change without notice.

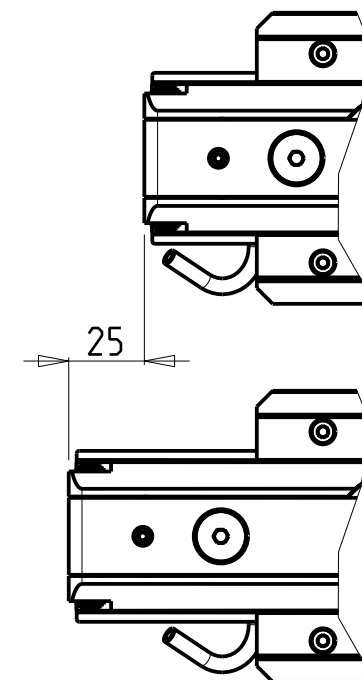
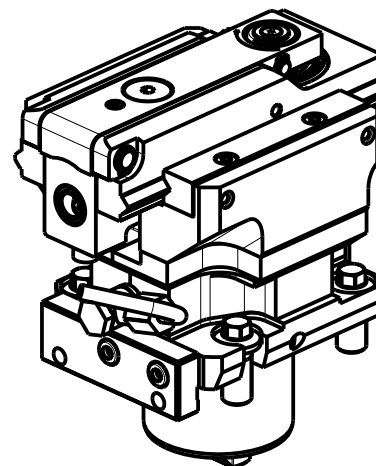
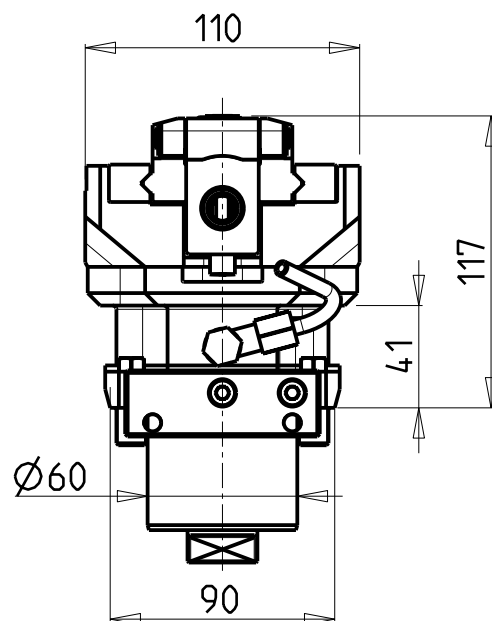
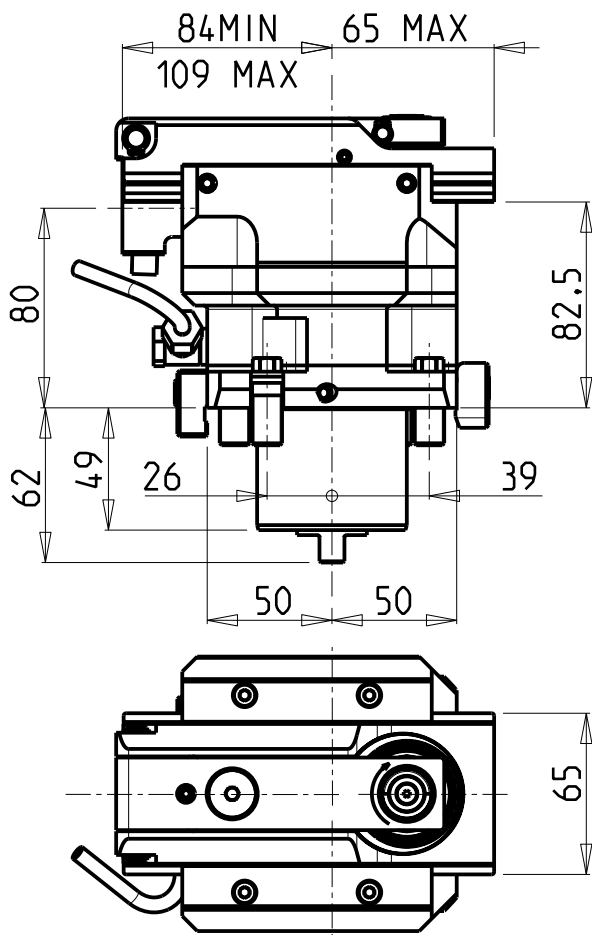

PER UTENSILI STOZZATORI VEDI PAG. TBL400-1-00
 FOR DRIVEN SLOTTING TOOL CUTTING-TOOLS SEE PAGE TBL400-1-00
 FÜR NUTENSTOSS-WERKZEUG SCHNEIDWERKZEUGE SIEHE SEITE TBL400-1-00

Cod. MT	I	RPM MAX	Reversibile lato mandrino/contromandrino Reversible sub/main spindle side Umkehrbare Spindelseite/ Gegenspindelseite	Lubr. esterna Ext. coolant Aussenkuehlung
OKU1160200	4:1	2400	X	X

OKUMA
 MOD: LB2000EX - LB2500EX - LB3000EX - LU2000EX - LU2500EX - LU3000EX - GENOS L300MW/MYW - GENOS L3000M
 MODULO MOTORIZZATO STOZZATORE CORSA 25mm H=80mm
 Slotting driven tool 25mm stroke H=80mm
 Keilnutenstossmaschine 25mm Hub H=80mm

M.T. srl
 Via Casino Albini 480
 Tel. 0541/956034-957884
 Fax 0541/956341
 47842 S. GIOVANNI IN M. (RN)
 e-mail: mtma@mtmarchetti.com
 http://www.mtmarchetti.com

PRODUZIONE MODULI ROTANTI

 PAGINA OKU360-4-01

Subject to change without notice.

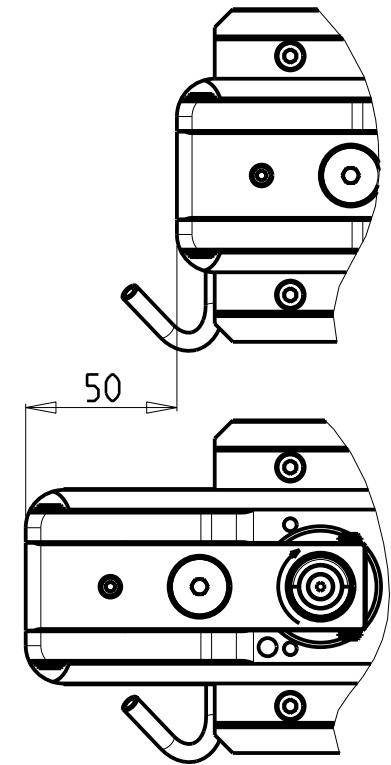
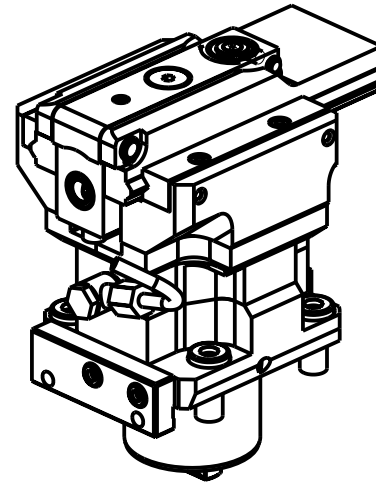
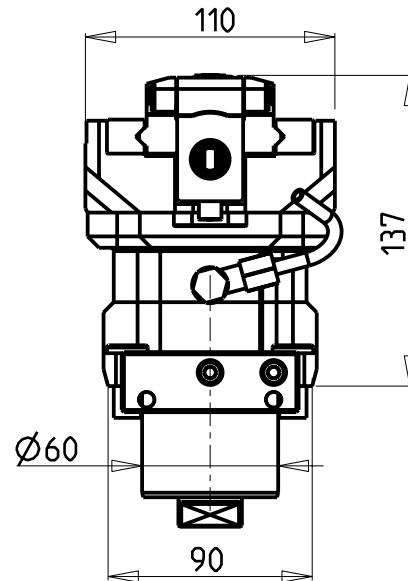
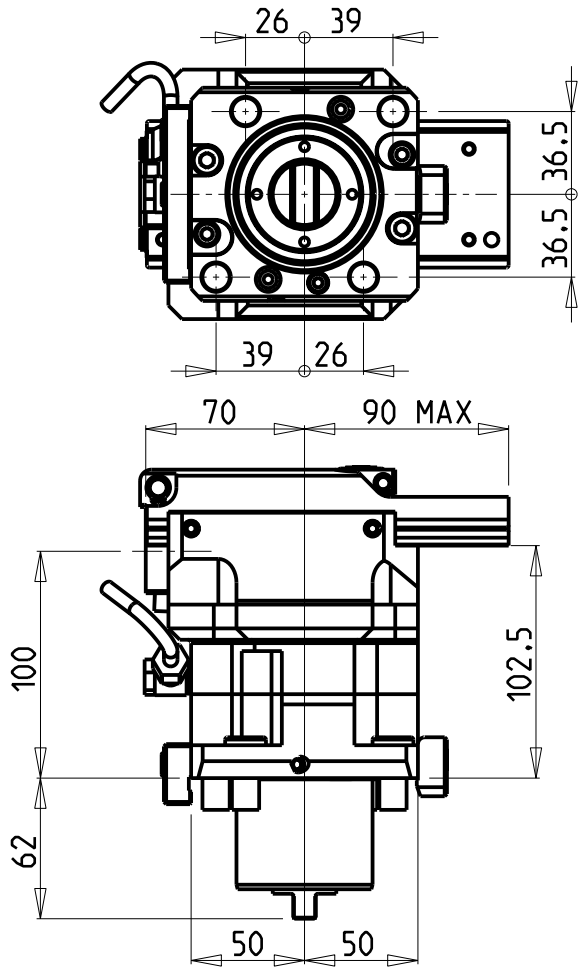
10/2018



PER UTENSILI STOZZATORI VEDI PAG. TBL400-1-00
 FOR DRIVEN SLOTTING TOOL CUTTING-TOOLS SEE PAGE TBL400-1-00
 FÜR NUTENSTOSS-WERKZEUG SCHNEIDWERKZEUGE SIEHE SEITE TBL400-1-00

Cod. MT	I	RPM MAX	Reversibile lato mandrino/contromandrino Reversible sub/main spindle side Umkehrbare Spindelseite/ Gegenspindelseite	Lubr. esterna Ext. coolant Aussenkuehlung
OKU1630100	4:1	2000	X	X

NEW

OKUMA

MOD: MULTUS U3000/4000 2SW - GENOS L300MW/MYW

MODULO MOTORIZZATO STOZZATORE CORSA 50mm H=100mm

Slotting driven tool 50mm stroke H=100mm

Keilnutenstossmaschine 50mm Hub H=100mm

Subject to change without notice.

M.T. srl

Via Casino Albini 480
 Tel. 0541/956034-957884
 Fax 0541/956341
 47842 S. GIOVANNI IN M. (RN)
 e-mail: mtma@mtmarchetti.com
 http://www.mtmarchetti.com

PRODUZIONE MODULI ROTANTI



PAGINA OKU360-4-10

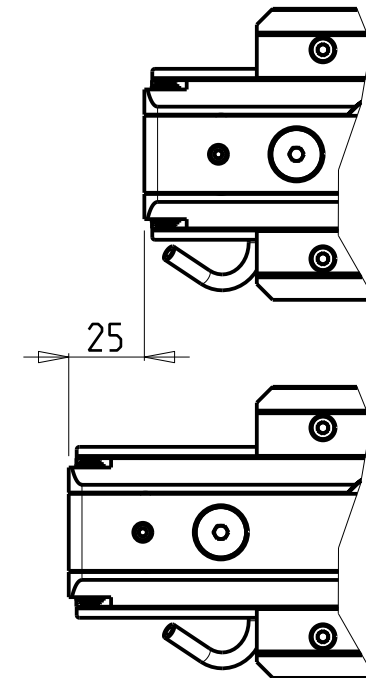
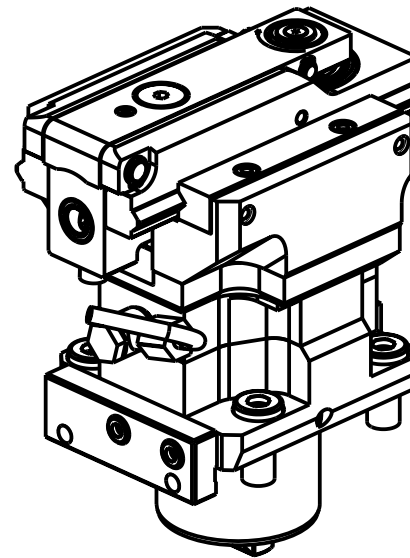
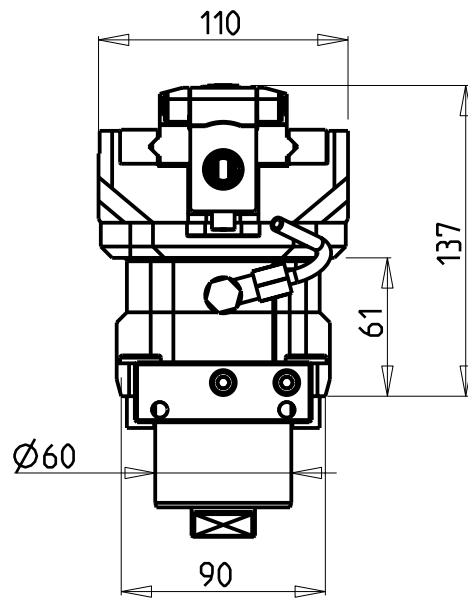
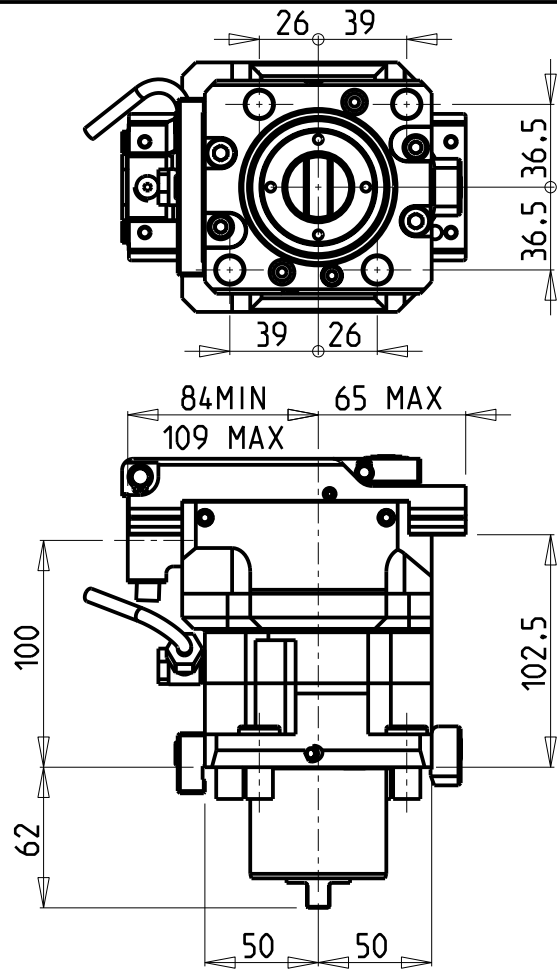

PER UTENSILI STOZZATORI VEDI PAG. TBL400-1-00
 FOR DRIVEN SLOTTING TOOL CUTTING-TOOLS SEE PAGE TBL400-1-00
 FÜR NUTENSTOSS-WERKZEUG SCHNEIDWERKZEUGE SIEHE SEITE TBL400-1-00

Cod. MT	I	RPM MAX	Reversibile lato mandrino/contromandrino Reversible sub/main spindle side Umkehrbare Spindelseite/ Gegenspindelseite	Lubr. esterna Ext. coolant Aussenkuehlung
OKU1630200	4:1	2400	X	X

NEW

OKUMA

MOD: MULTUS U3000/4000 2SW - GENOS L300MW/MYW

MODULO MOTORIZZATO STOZZATORE CORSA 25mm H=100mm

Slotting driven tool 25mm stroke H=100mm

Keilnutenstossmaschine 25mm Hub H=100mm

Subject to change without notice.

M.T. srl

Via Casino Albini 480
 Tel. 0541/956034-957884
 Fax 0541/956341
 47842 S. GIOVANNI IN M. (RN)
 e-mail: mtma@mtmarchetti.com
 http://www.mtmarchetti.com

PRODUZIONE MODULI ROTANTI



PAGINA OKU360-4-11

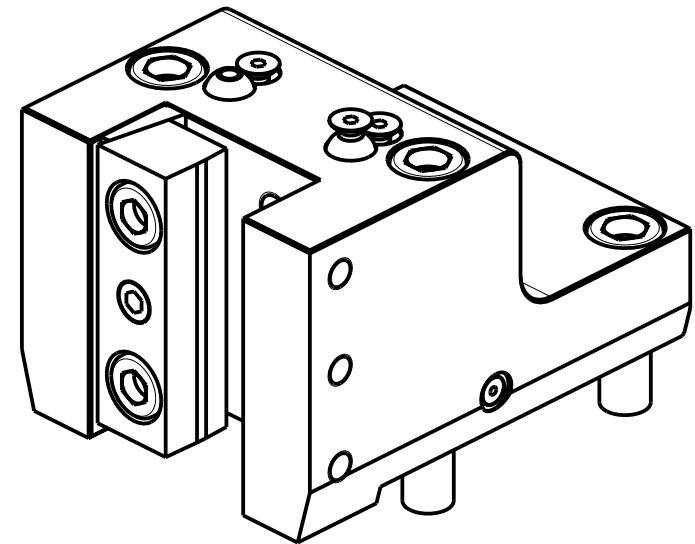
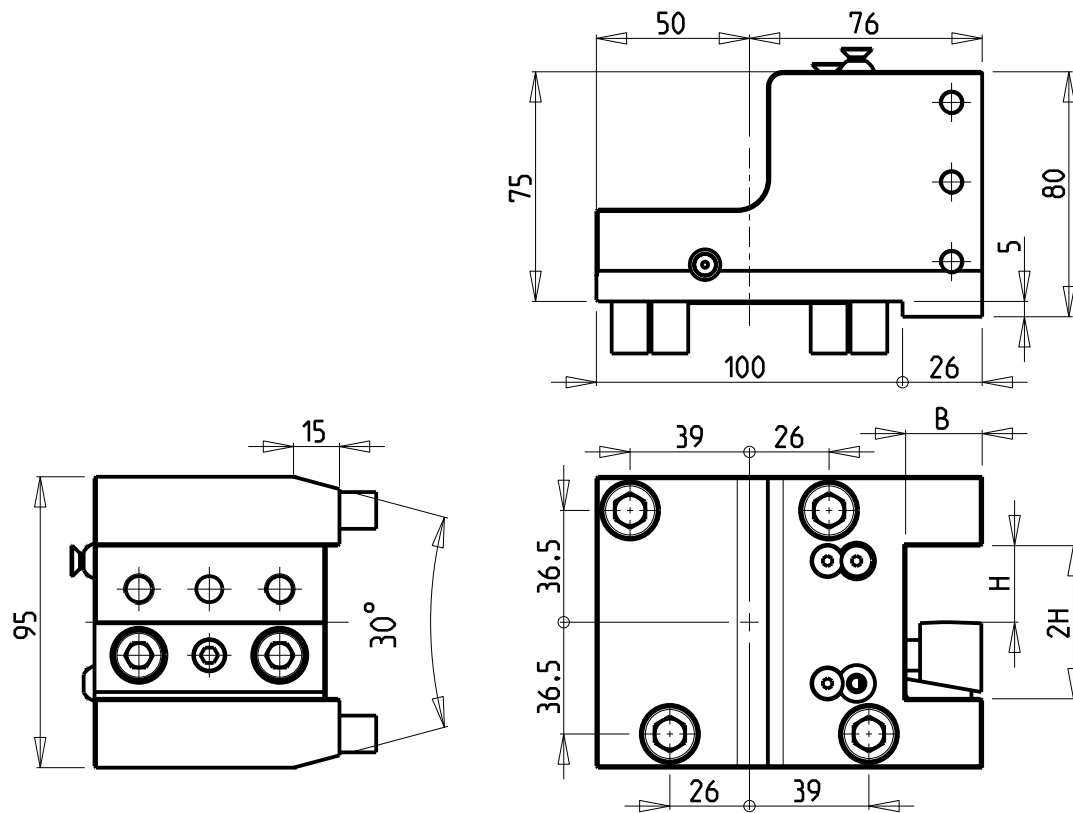

Cod. MT	N°Utensili N°Tools N°Werkzeuge	Reversibile lato mandrino/contromandrino Reversible sub/main spindle side Umkehrbare Spindel-seite/ Gegenspindel-seite	Lubrificazione est. Ext. coolant Aussenkuehlung	Misure Dimensions Masse	B	H
OKU0092500	1/2	X	X	mm	25	25
OKU0092540	1/2	X	X	Inch	1"	1"
OKU0092000	1/2	X	X	mm	20	20
OKU0091905	1/2	X	X	Inch	3/4"	3/4"

OKUMA
 MOD: LB2000EX - LB2500EX - LB3000EX - LU2000EX - LU2500EX - LU3000EX - MULTUS U3000/4000 2SW
 GENOS L300MW/MYW - GENOS L3000M

PORTAUTENSILE RADIALE SINGOLO QD=20mm / QD=3/4" / QD=25mm / QD=1"
 Radial single static tool QD=20mm / QD=3/4" / QD=25mm / QD=1"
 Radial Single-Werkzeughalter QD=20mm / QD=3/4" / QD=25mm / QD=1"

Subject to change without notice.

M.T. srl

Via Casino Albini 480
 Tel. 0541/956034-957884
 Fax 0541/956341
 47842 S. GIOVANNI IN M. (RN)
 e-mail: mtma@mtmarchetti.com
 http://www.mtmarchetti.com

PRODUZIONE MODULI ROTANTI



PAGINA OKU423-4-00

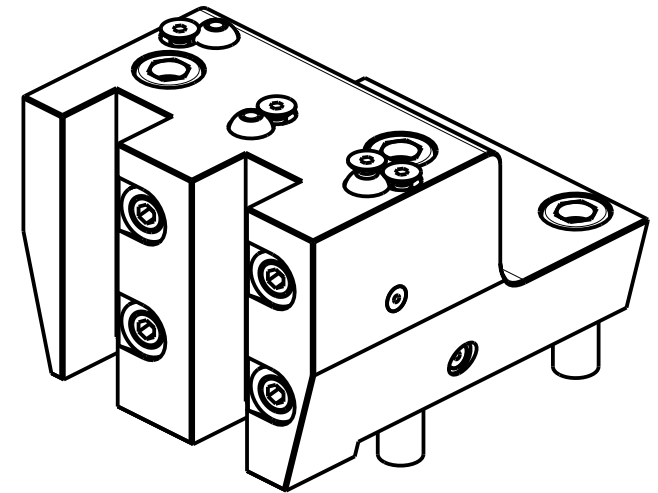
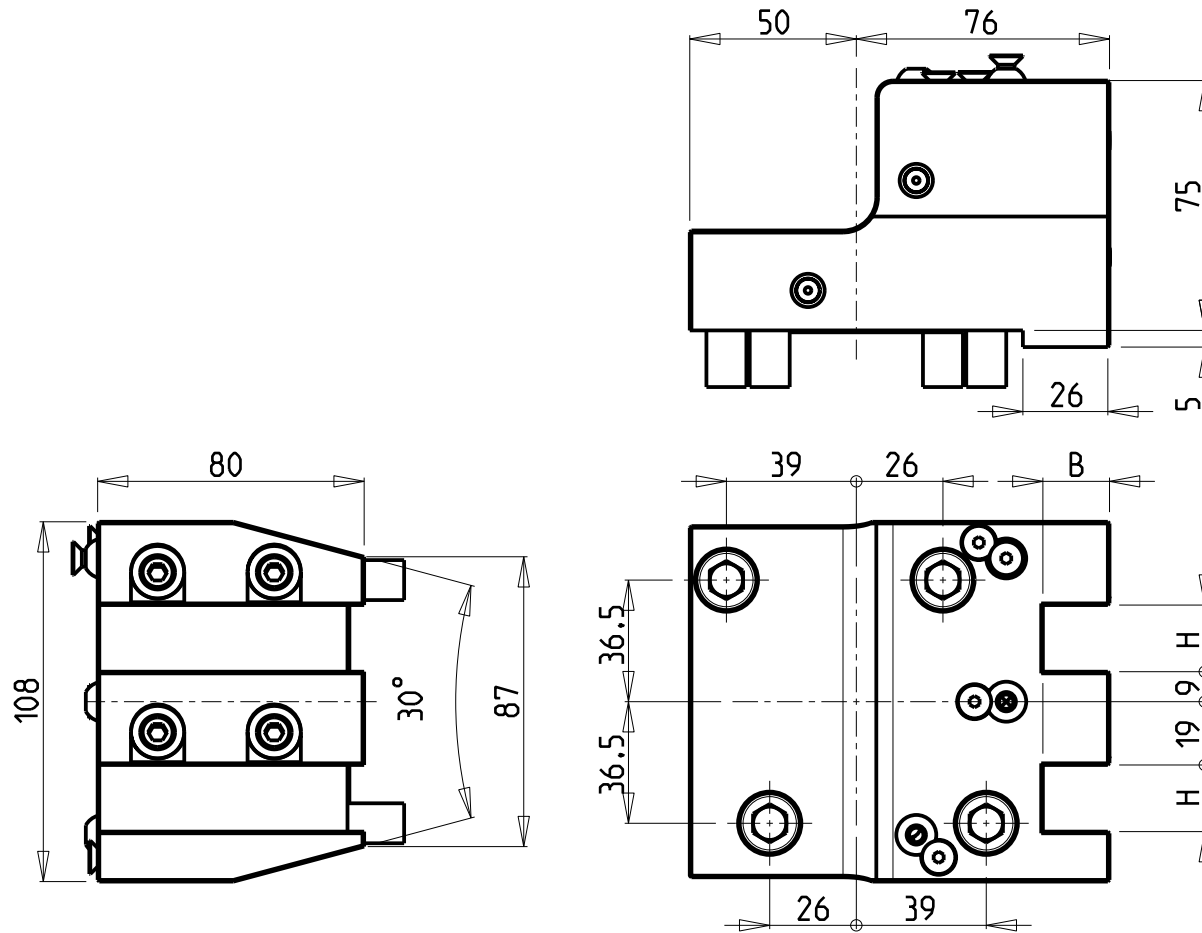

Cod. MT	N°Utensili N°Tools N°Werkzeuge	Reversibile lato mandrino/contromandrino Reversible sub/main spindle side Umkehrbare Spindel-seite/ Gegenspindel-seite	Lubrificazione est. Ext. coolant Ausseukuehlung	Misure Dimensions Masse	B	H
OKU0182000	2	X	X	mm	20	20
OKU0181905	2	X	X	Inch	3/4"	3/4"

OKUMA
 MOD: LB2000EX - LB2500EX - LB3000EX - LU2000EX - LU2500EX - LU3000EX - GENOS L300MW /MYW

PORTAUTENSILE RADIALE SOVRAPPOSTO QD=20mm / QD=3/4"
 Radial single side twin static tool QD=20mm / QD=3/4"
 Radial Werkzeughalter ueberlagert QD=20mm / QD=3/4"

Subject to change without notice.

M.T. srl
 Via Casino Albini 480
 Tel. 0541/956034-957884
 Fax 0541/956341
 47842 S. GIOVANNI IN M. (RN)
 e-mail: mtma@mtmarchetti.com
 http://www.mtmarchetti.com

PRODUZIONE MODULI ROTANTI



PAGINA OKU440-4-00

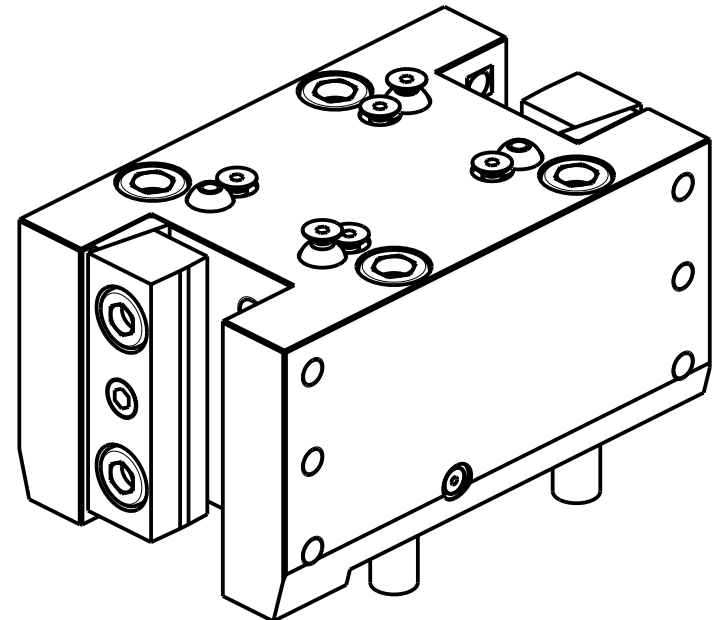
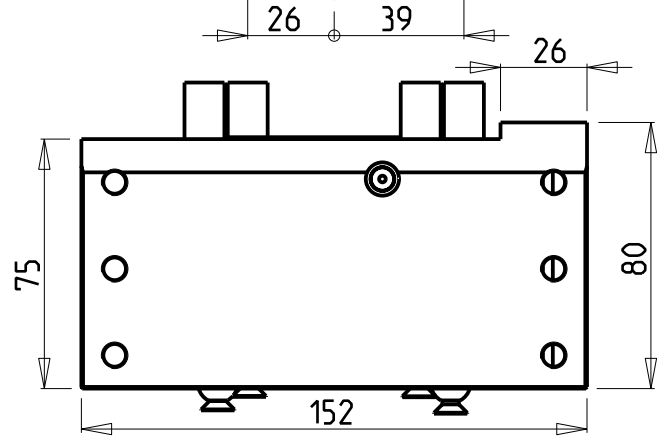
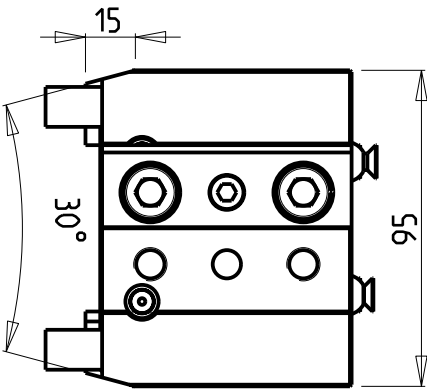
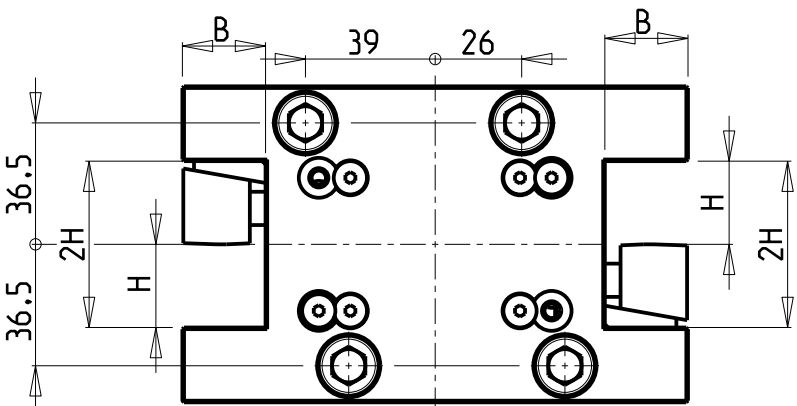

Cod. MT	N°Utensili N°Tools N°Werkzeuge	Reversibile lato mandrino/controlmandrino Reversible sub/main spindle side Umkehrbare Spindel-seite/ Gegenspindel-seite	Lubrificazione est. Ext. coolant Aussehenkuehlung	Misure Dimensions Masse	B	H
OKU0152500	2/4	X	X	mm	25	25
OKU0152540	2/4	X	X	Inch	1"	1"
OKU0152000	2/4	X	X	mm	20	20
OKU0151905	2/4	X	X	Inch	3/4"	3/4"

OKUMA
 MOD: LB2000EX - LB2500EX - LB3000EX - LU2000EX - LU2500EX - LU3000EX - MULTUS U3000/4000 2SW
 GENOS L300MW/MYW

PORTAUTENSILE RADIALE DOPPIO QD=20mm / QD=3/4" / QD=25mm / QD=1"
 Radial double static tool QD=20mm / QD=3/4" / QD=25mm / QD=1"
 Radial Doppel-Werkzeughalter QD=20mm / QD=3/4" / QD=25mm / QD=1"

Subject to change without notice.

M.T. srl
 Via Casino Albini 480
 Tel. 0541/956034-957884
 Fax 0541/956341
 47842 S. GIOVANNI IN M. (RN)
 e-mail: mtma@mtmarchetti.com
 http://www.mtmarchetti.com

PRODUZIONE MODULI ROTANTI

PAGINA OKU450-4-00

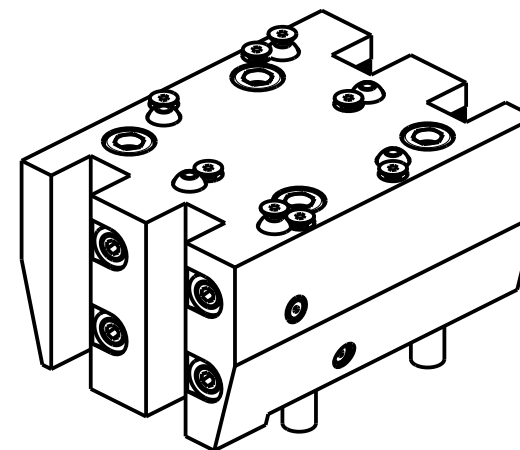
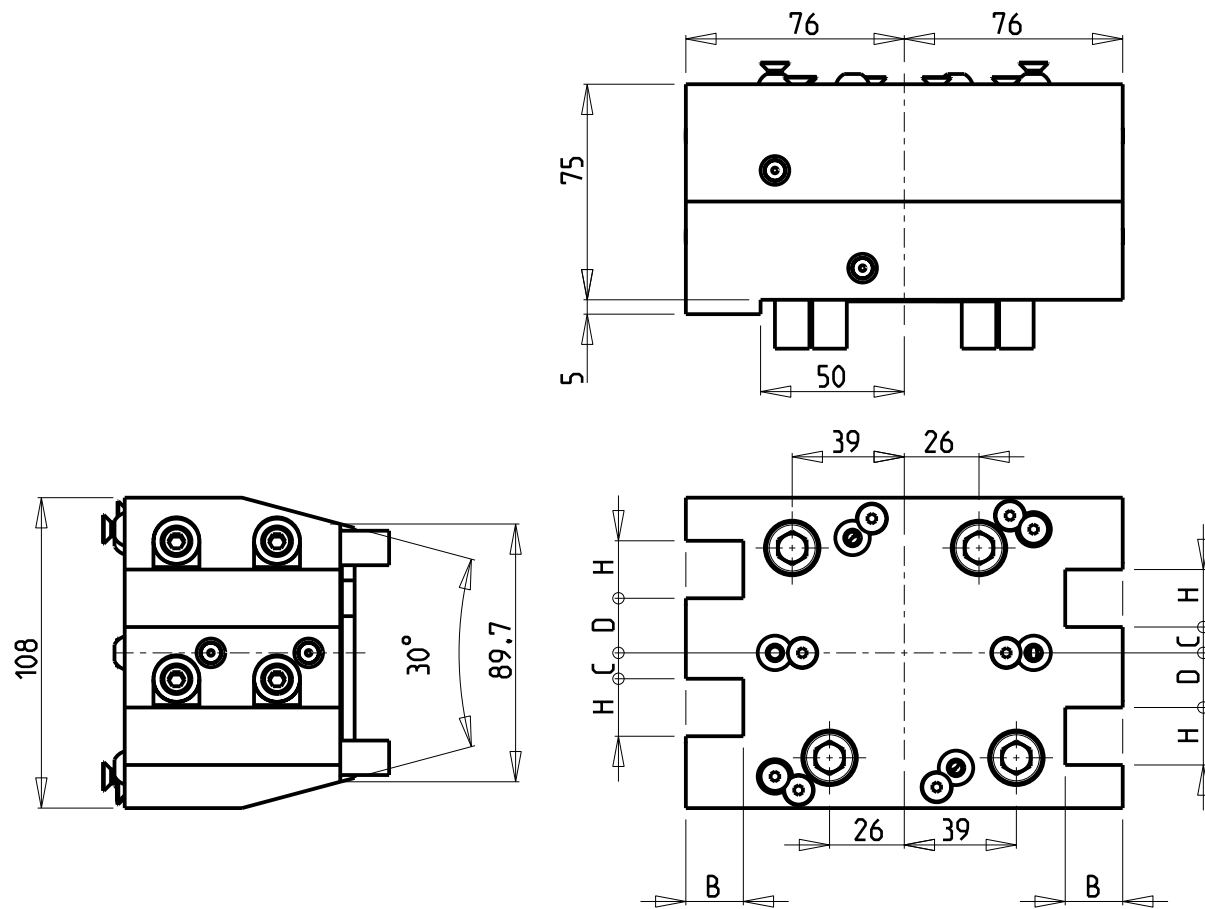

Cod. MT	N°Utensili N°Tools N°Werkzeuge	Reversibile lato mandrino/contromandrino Reversible sub/main spindle side Umkehrbare Spindel-seite/ Gegenspindel-seite	Lubrificazione est. Ext. coolant Auslenkuehlung	Misure Dimensions Masse	B	H	C	D
OKU1342000	2+2	X	X	mm	20	20	9	19
OKU1341905	2+2	X	X	Inch	3/4"	3/4"	5/16"	3/4"

OKUMA
 MOD: LB2000EX - LB2500EX - LB3000EX - LU2000EX - LU2500EX - LU3000EX - GENOS L300MW /MYW

PORTAUTENSILE RADIALE DOPPIO SOVRAPPOSTO QD=20mm / QD=3/4"
 Radial double side twin static tool QD=20mm / QD=3/4"
 Radial Doppel-Werkzeughalter ueberlagert QD=20mm / QD=3/4"

Subject to change without notice.

M.T. srl

Via Casino Albini 480
 Tel. 0541/956034-957884
 Fax 0541/956341
 47842 S. GIOVANNI IN M. (RN)
 e-mail: mtma@mtmarchetti.com
 http://www.mtmarchetti.com

PRODUZIONE MODULI ROTANTI



PAGINA OKU460-4-00

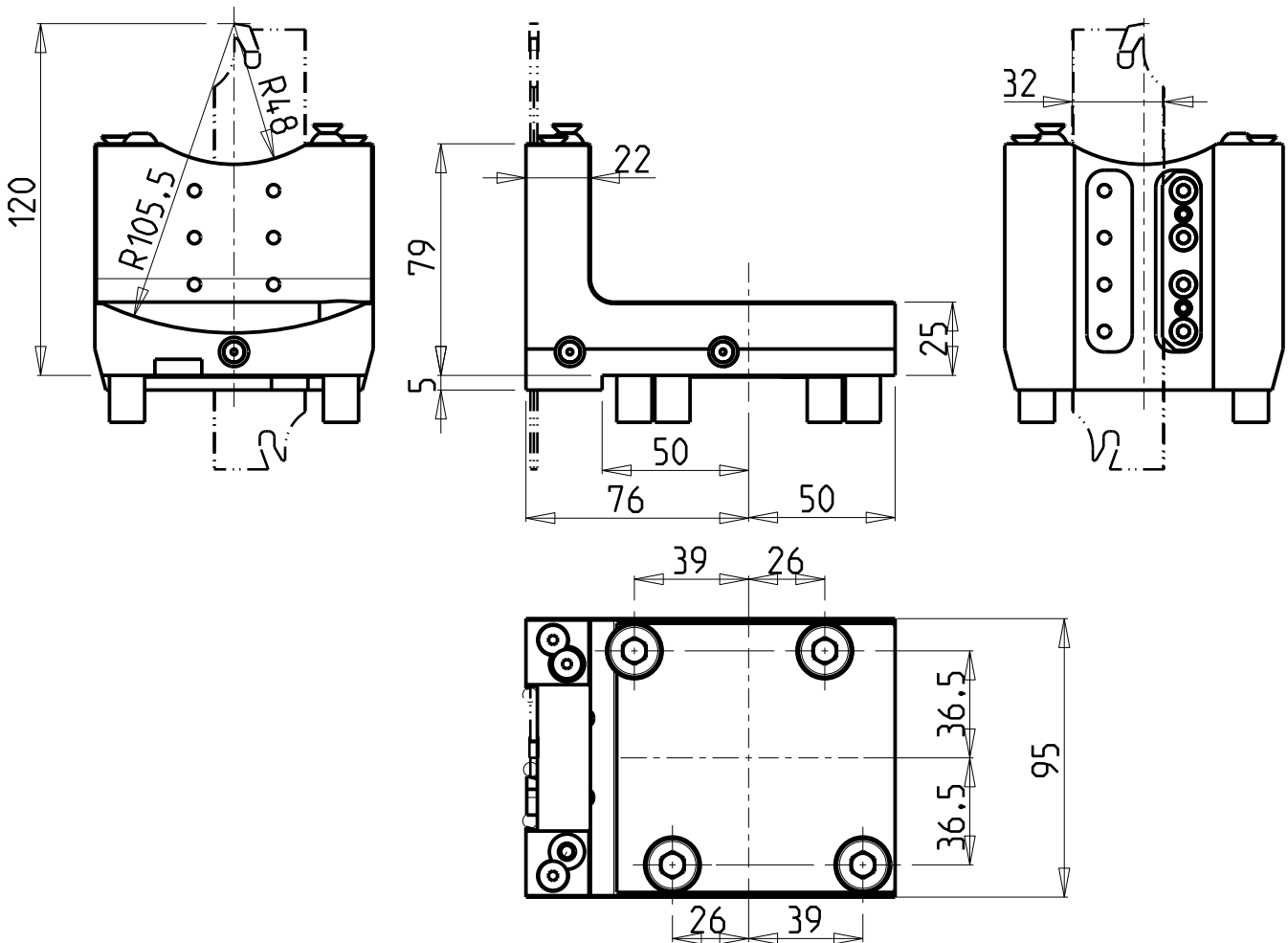

POSSIBILITA' DI LAVORO M3/M4
 OPTION OF M3/M4 WORKING
 ARBEITSMOEGlichkeit M3/M4

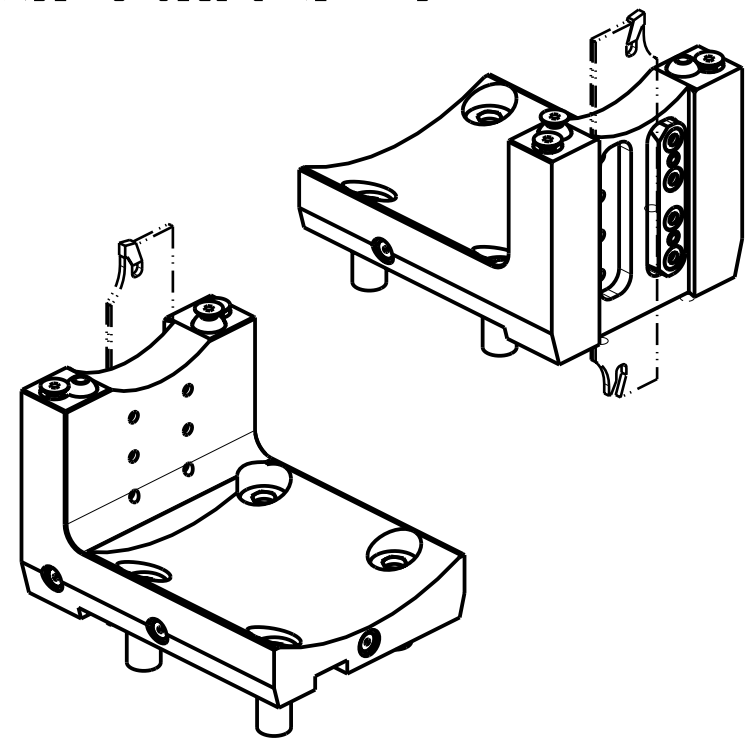

DOTAZIONI - SUPPLIED WITH - AUSSTATTUNG

- N°1 - LAMA - BLADE - KLINGE ISCAR H-32 Sp. 3/4mm (KENNAMETAL OPTIONAL)
- N°10 - INSERTI - INSERTS - EINLAGEN
- N°1 - CHIAVE A T PER MONTAGGIO INSERTI
 - T-WRENCH FOR INSERT SET UP
 - T-SCHLUESSEL FUER EINSATZSTUECK-MONTAGE

Cod. MT	N°Utensili N°Tools N°Werkzeuge	Reversibile lato mandrino/contromandrino Reversible sub/main spindle side Umkehrbare Spindel-seite/ Gegenspindel-seite	Lubr.esterna Ext. coolant Aussenkuehlung
OKU0230232	1	X	X

OKUMA
 MOD: LB2000EX - LB2500EX - LB3000EX - LU2000EX - LU2500EX - LU3000EX - MULTUS U3000/4000 2SW
 GENOS L300MW/MYW - GENOS L3000M

PORTAUTENSILE RADIALE PER LAMA
 Radial blade holder
 Radial Abstechhalter

Subject to change without notice.

M.T. srl
 Via Casino Albini 480
 Tel. 0541/956034-957884
 Fax 0541/956341
 47842 S. GIOVANNI IN M. (RN)
 e-mail: mtma@mtmarchetti.com
 http://www.mtmarchetti.com

PRODUZIONE MODULI ROTANTI



PAGINA OKU510-4-00

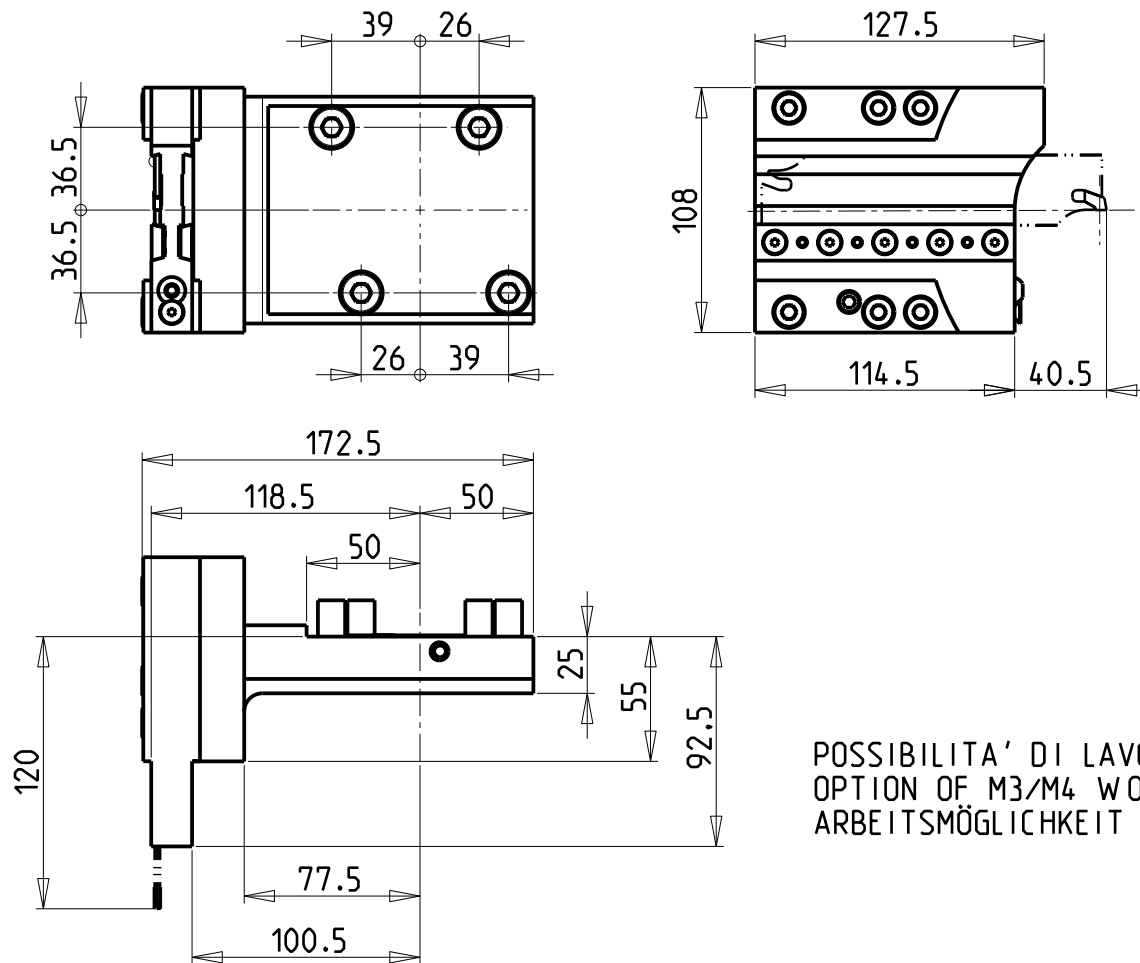

POSSIBILITA' DI LAVORO M3/M4
 OPTION OF M3/M4 WORKING
 ARBEITSMÖGLICHKEIT M3/M4

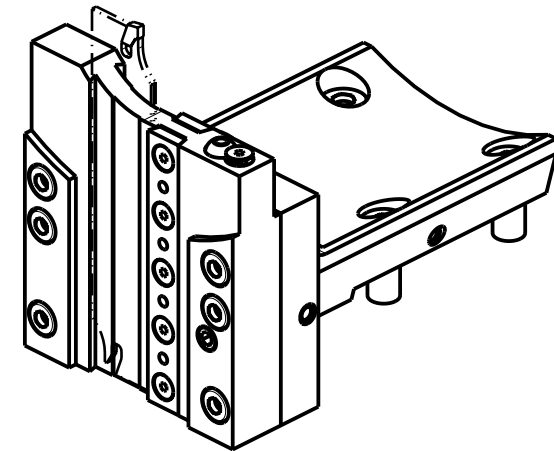

DOTAZIONI - SUPPLIED WITH - AUSSTATTUNG

- N°1 - LAMA - BLADE - KLINGE ISCAR H=32 Sp. 3/4mm
(KENNAMETAL OPTIONAL)
- N°10 - INSERTI - INSERTS - EINLAGEN
- N°1 - CHIAVE A T PER MONTAGGIO INSERTI
 - T-WRENCH FOR INSERT SET UP
 - T-SCHLUESSEL FUER EINSATZSTUECK-MONTAGE

Cod. MT

N°Utensili
 N°Tools
 N°Werkzeuge

OKU1520132

1

OKUMA

MOD: LB2000EX - LB2500EX - LB3000EX - LU2000EX - LU2500EX - LU3000EX - MULTUS U3000/4000 2SW
 GENOS L300MW/MYW - GENOS L3000M

PORTAUTENSILE PER LAMA DOPPIO

Radial double blade holder
 Radial Doppel-Abstechhalter

Subject to change without notice.

M.T. srl

Via Casino Albini 480
 Tel. 0541/956034-957884
 Fax 0541/956341
 47842 S. GIOVANNI IN M. (RN)
 e-mail: mtma@mtmarchetti.com
 http://www.mtmarchetti.com

PRODUZIONE MODULI ROTANTI



PAGINA OKU520-4-00

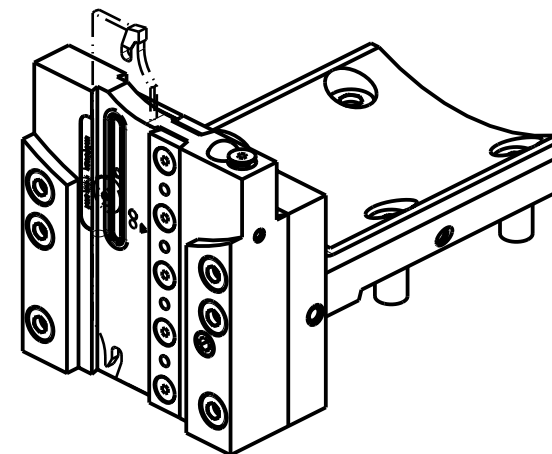
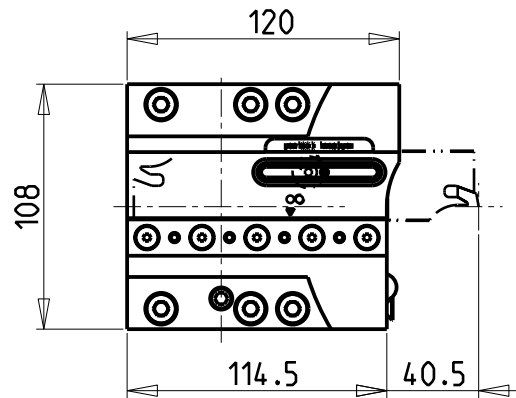
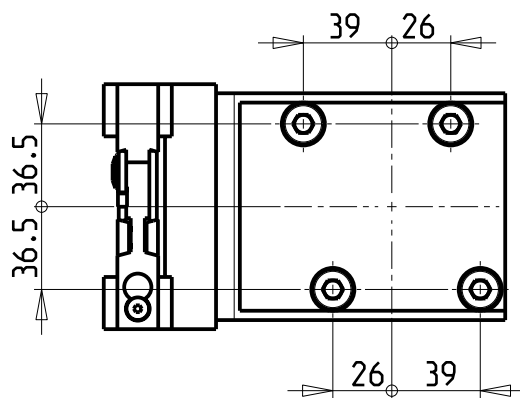

POSSIBILITA' DI LAVORO M3/M4
 OPTION OF M3/M4 WORKING
 ARBEITSMÖGLICHKEIT M3/M4

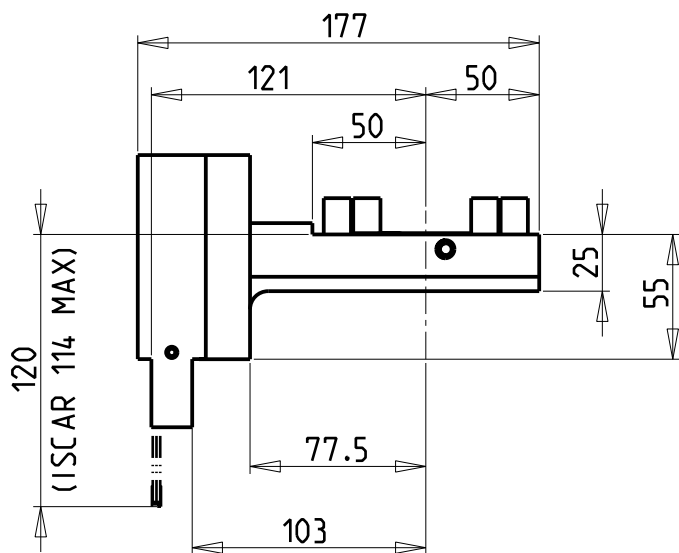

KIT LAME NON INCLUSI (OPZIONALI)
BLADES NOT SUPPLIED WITH (OPTIONAL)
KLINGEN NICHT INBEGRIFFEN (OPTIONAL)

- LAMA-BLADE-KLINGE SANDVIK H=32 sp.3 cod. QD_NN2G60C 25A
 +INSERTI-INSERTS-EINLAGEN cod. QD_NG_0300_0002_CM_1145 (10 pz.)
- LAMA-BLADE-KLINGE SANDVIK H=32 sp.4 cod. QD_NN2H60C 25A
 +INSERTI-INSERTS-EINLAGEN cod. QD_NH_0400_0002_CM_1145 (10 pz.)
- LAMA-BLADE-KLINGE ISCAR H=32 sp.3 cod. SGFH_32K_3
 +INSERTI-INSERTS-EINLAGEN cod. 6011365 (10pz.)
- LAMA-BLADE-KLINGE ISCAR H=32 sp.4 cod. SGFH_32K_4
 +INSERTI-INSERTS-EINLAGEN cod. 6011366 (10pz.)
- LAMA-BLADE-KLINGE WALTER H=32 sp.3 cod. G2042.32N-3T45SX-P
 +INSERTI-INSERTS-EINLAGEN cod. SX-3E300N02-CE4 WSM33S (10pz.) + CHIAVE-KEY cod. FS1494
- LAMA-BLADE-KLINGE WALTER H=32 sp.4 cod. G2042.32N-4T50SX-P
 +INSERTI-INSERTS-EINLAGEN cod. SX-4E400N02-CE4 WSM33S (10pz.) + CHIAVE-KEY cod. FS1494

Cod. MT	N°Utensili N°Tools N°Werkzeuge	Lubr.esterna Ext. coolant Aussenkuehlung	Lubr.interna Coolant through Innenkuehlung
OKU1530132	1	X	P=70bar

OKUMA
 MOD: LB2000EX - LB2500EX - LB3000EX - LU2000EX - LU2500EX - LU3000EX - MULTUS U3000/4000 2SW
 GENOS L300MW/MYW - GENOS L3000M

PORTAUTENSILE PER LAMA DOPPIO CON LUBRIFICAZIONE INTERNA
 Radial double blade holder with internal coolant
 Radial Doppel-Abstechhalter mit Innenkuehlung

Subject to change without notice.

M.T. srl
 Via Casino Albini 480
 Tel. 0541/956034-957884
 Fax 0541/956341
 47842 S. GIOVANNI IN M. (RN)
 e-mail: mtma@mtmarchetti.com
 http://www.mtmarchetti.com

PRODUZIONE MODULI ROTANTI



PAGINA OKU520-4-04

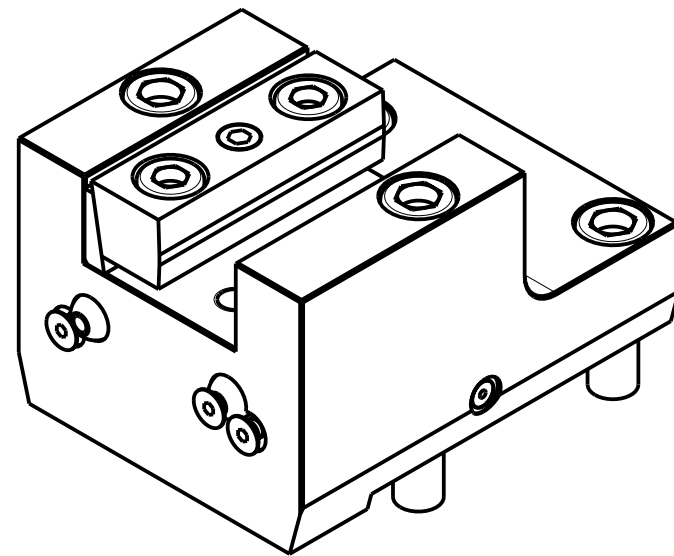
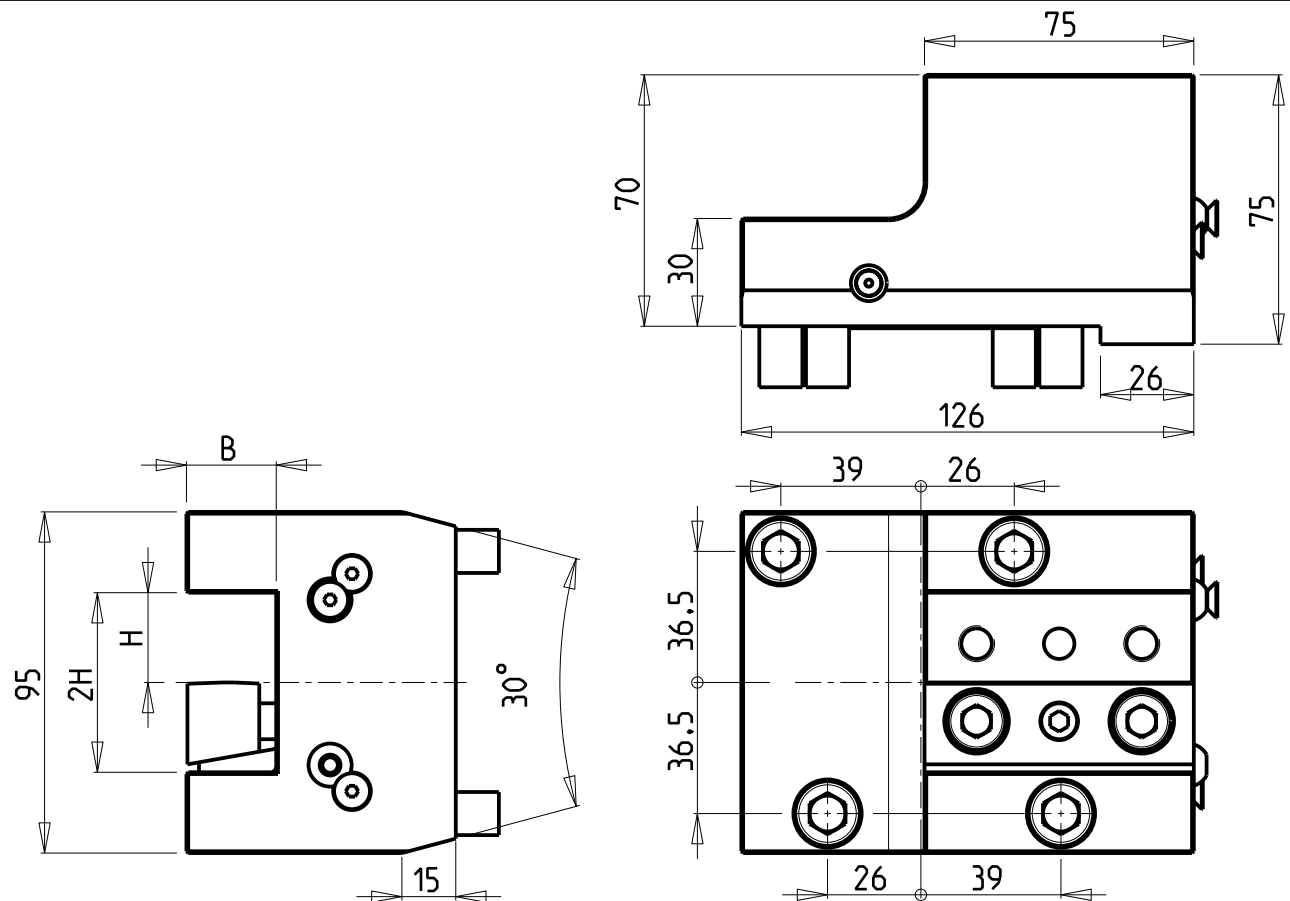

Cod. MT	N°Utensili N°Tools N°Werkzeuge	Reversibile lato mandrino/contromandrino Reversible sub/main spindle side Umkehrbare Spindel-seite/ Gegenspindel-seite	Lubrificazione est. Ext. coolant Aussenkuehlung	Misure Dimensions Masse	B	H
OKU0162500	1	X	X	mm	25	25
OKU0162540	1	X	X	Inch	1"	1"
OKU0161905	1	X	X	Inch	3/4"	3/4"

OKUMA
 MOD: LB2000EX - LB2500EX - LB3000EX - LU2000EX - LU2500EX - LU3000EX - GENOS L300MW/MYW - GENOS L3000M

PORTAUTENSILE ASSIALE SINGOLO QD=3/4" / QD=25mm / QD=1"
 Axial single static tool QD=3/4" / QD=25mm / QD=1"
 Axial Single-Werkzeughalter QD=3/4" / QD=25mm / QD=1"

Subject to change without notice.

M.T. srl
 Via Casino Albini 480
 Tel. 0541/956034-957884
 Fax 0541/956341
 47842 S. GIOVANNI IN M. (RN)
 e-mail: mtma@mtmarchetti.com
 http://www.mtmarchetti.com

PRODUZIONE MODULI ROTANTI



PAGINA OKU552-4-00

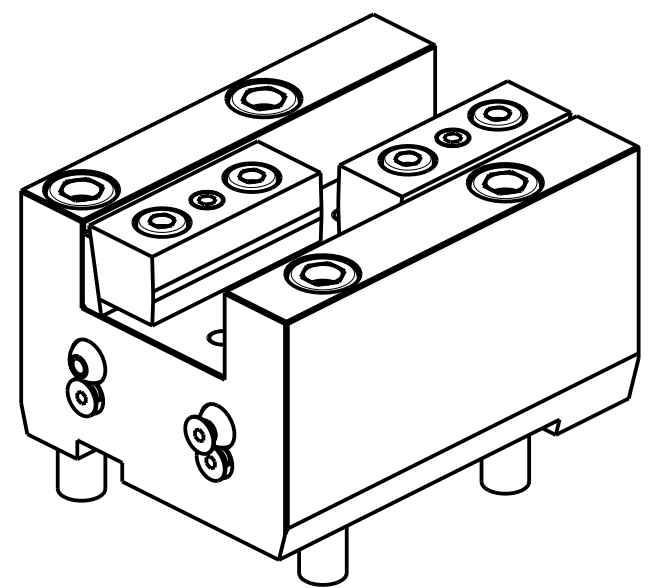
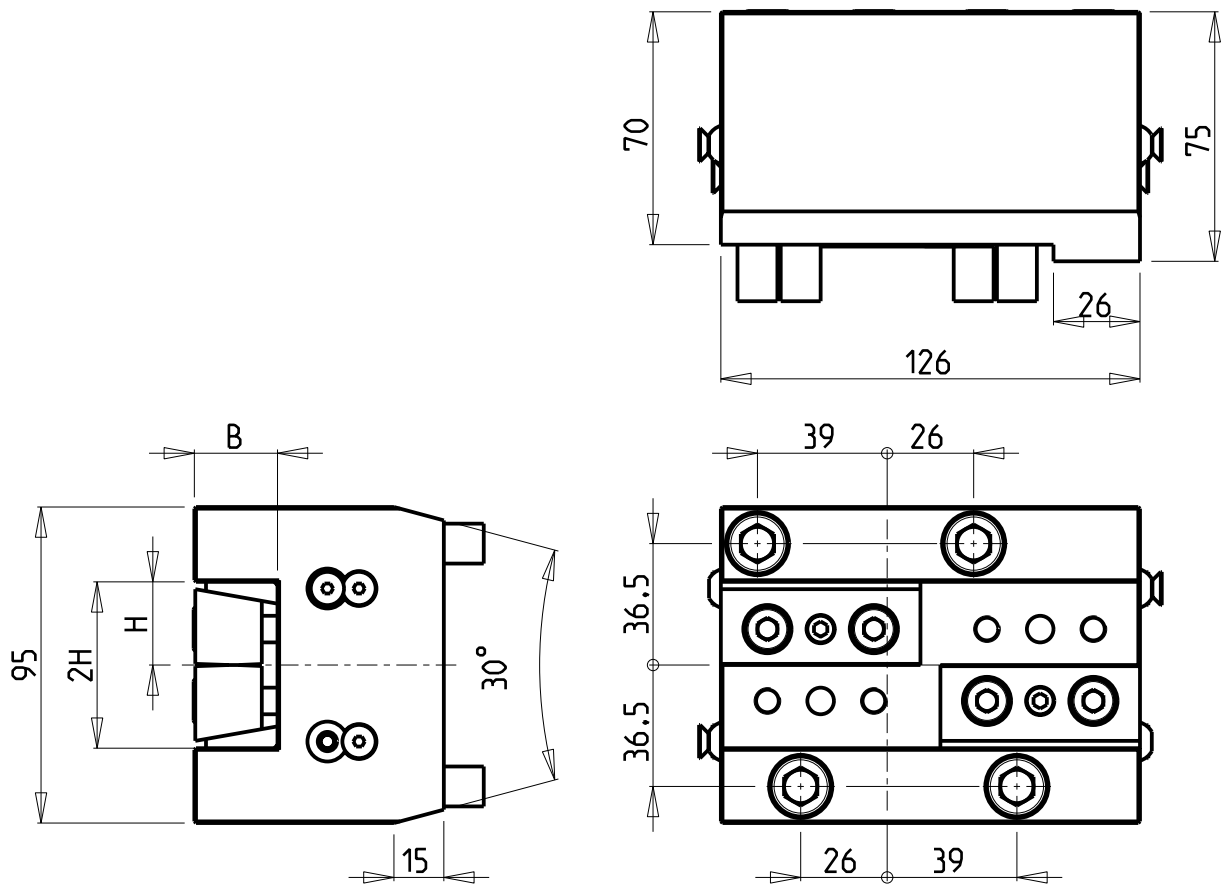

Cod. MT	N°Utensili N°Tools N°Werkzeuge	Reversibile lato mandrino/controlmandrino Reversible sub/main spindle side Umkehrbare Spindel-seite/ Gegenspindel-seite	Lubr.esterna Ext. coolant Aussenkuehlung	Misure Dimensions Masse	B	H
OKU0172500	2	X	X	mm	25	25
OKU0172540	2	X	X	Inch	1"	1"

OKUMA
 MOD: LB2000EX - LB2500EX - LB3000EX - LU2000EX - LU2500EX - LU3000EX - GENOS L300MW /MYW

PORTAUTENSILE ASSIALE DOPPIO QD=25mm / QD=1"
 Axial double static tool QD=25mm / QD=1"
 Axial doppel-Werkzeughalter QD=25mm / QD=1"

Subject to change without notice.

M.T. srl
 Via Casino Albini 480
 Tel. 0541/956034-957884
 Fax 0541/956341
 47842 S. GIOVANNI IN M. (RN)
 e-mail: mtma@mtmarchetti.com
 http://www.mtmarchetti.com

PRODUZIONE MODULI ROTANTI

PAGINA OKU572-4-00

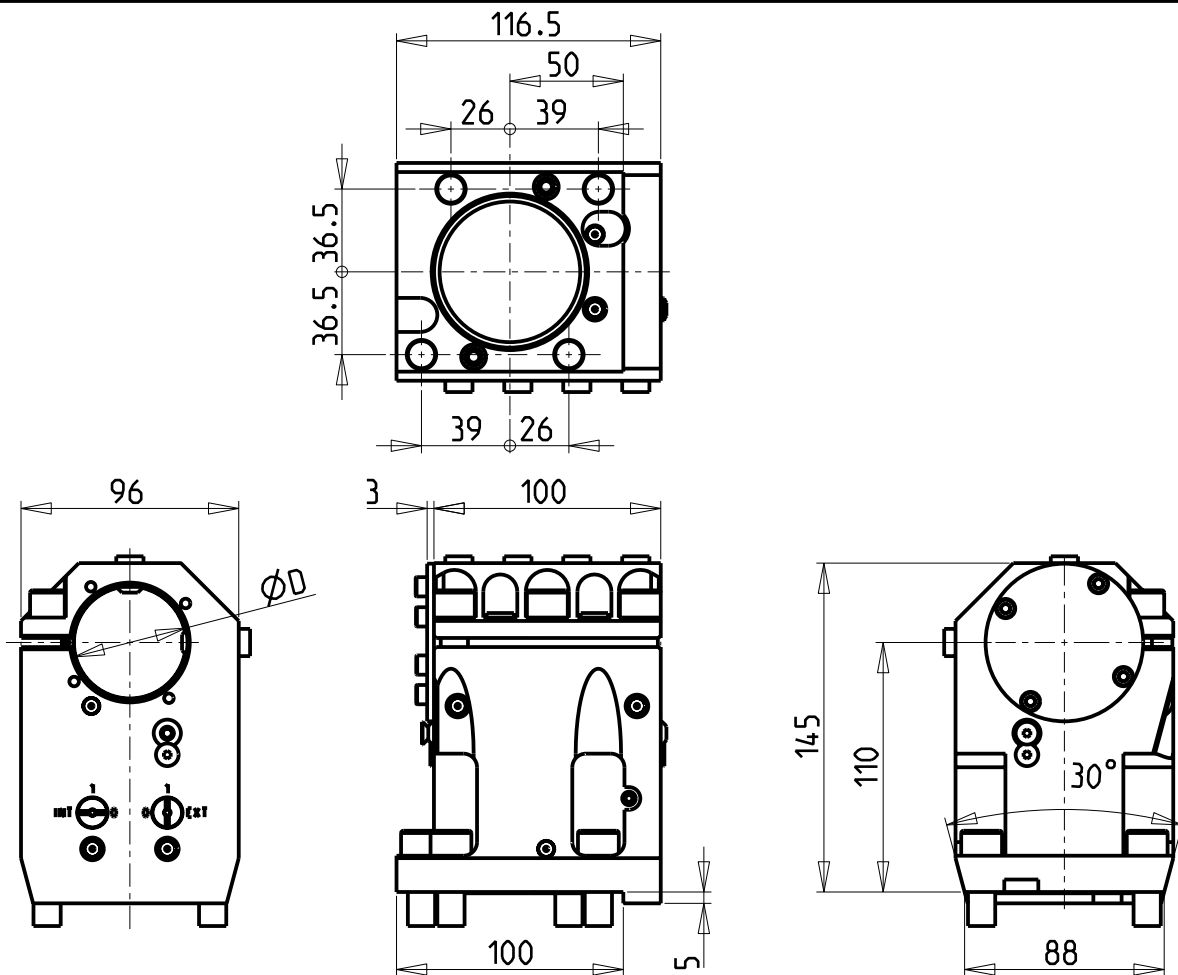

KIT ADDUZIONE INTERNA (OPZIONALE)
 KIT FOR INTERNAL COOLANT (OPTIONAL)
 KIT FUER INTERNE KUEHLMITTELZUFUHR (OPTIONAL)
 Ø2" cod. KIT1007002

SOLO GUARNIZIONE (OPZIONALE)
 ONLY SEAL (OPTIONAL)
 NUR DICHTUNG (OPTIONAL)
 cod. NKM0470004

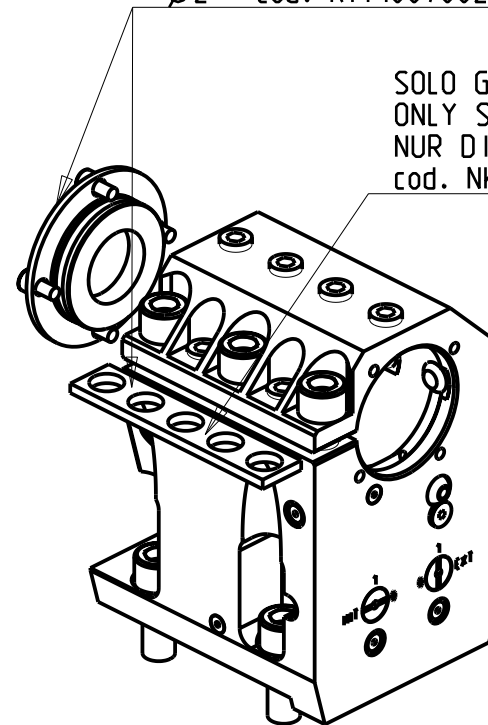

PER BOCCOLE DI RIDUZIONE VEDI PAG. TBL150-1-00
 FOR REDUCING BUSHINGS SEE PAGE TBL150-1-00
 FUR REDUZIERBUCHSE SIEHE SEITE TBL150-1-00

Cod. MT	N°Utensili N°Tools N°Werkzeuge	Reversibile lato mandrino/contromandrino Reversible sub/main spindle side Umkehrbare Spindel-seite/ Gegenspindel-seite	Lubrificazione int. opzionale Coolant through optional Innenkuehlung Optional	Lubrificazione est. Ext. coolant Aussenkuehlung	Misure Dimensions Masse	D
OKU1495080	1	X	X	X	inch	2" NEW

OKUMA

MOD: MULTUS U3000/4000 2SW

PORTAUTENSILE ASSIALE PER BARENO Ø2" H=110mm

Axial single boring bar holder Ø2" H=110mm

Axial Bohrhalter Ø2" H=110mm

Subject to change without notice.

M.T. srl

Via Casino Albini 480
 Tel. 0541/956034-957884
 Fax 0541/956341
 47842 S. GIOVANNI IN M. (RN)
 e-mail: mtma@mtmarchetti.com
 http://www.mtmarchetti.com

PRODUZIONE MODULI ROTANTI



PAGINA OKU620-4-20

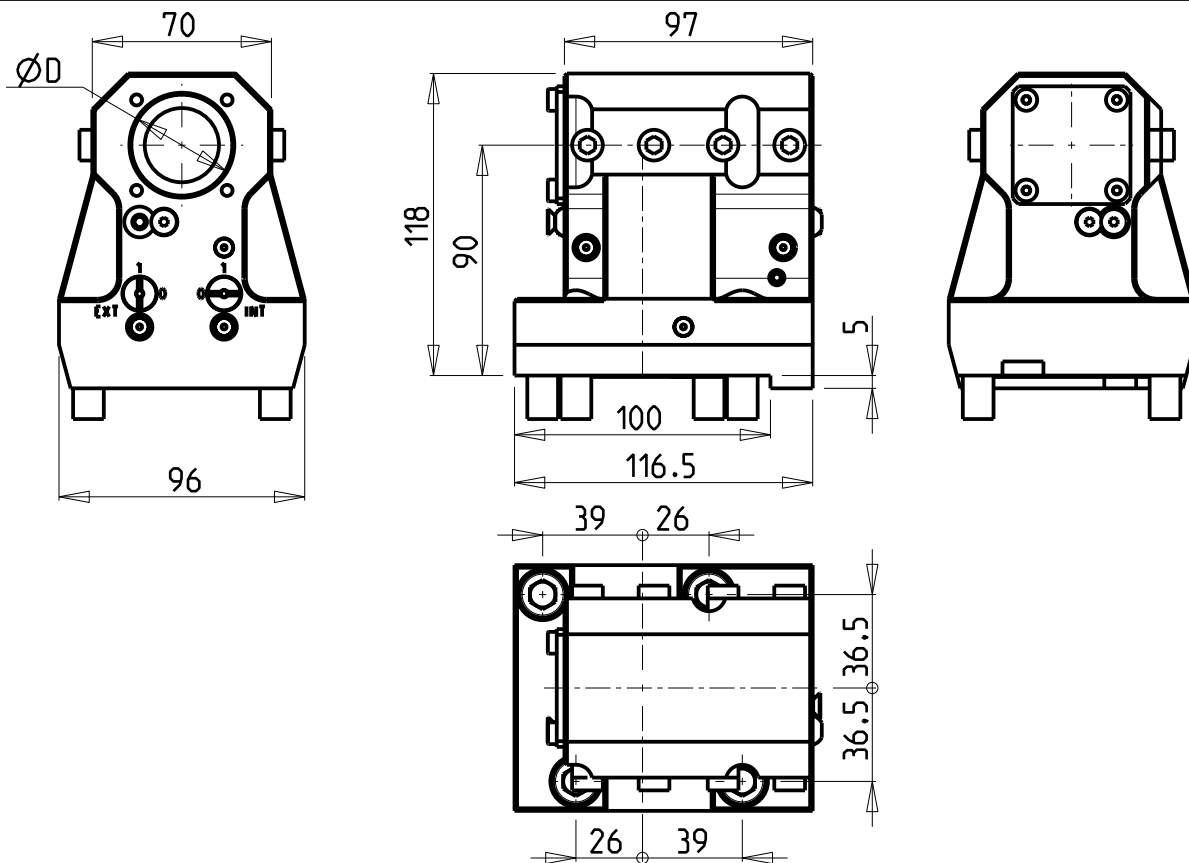

KIT ADDUZIONE INTERNA (OPZIONALE)
 KIT FOR INTERNAL COOLANT (OPTIONAL)
 KIT FUER INTERNE KUEHLMITTELZUFUHR (OPTIONAL)
 Ø32-Ø1 1/4" cod. KIT1000020
 Ø40 cod. KIT1000019
 Ø1 1/2" cod. KIT1000023

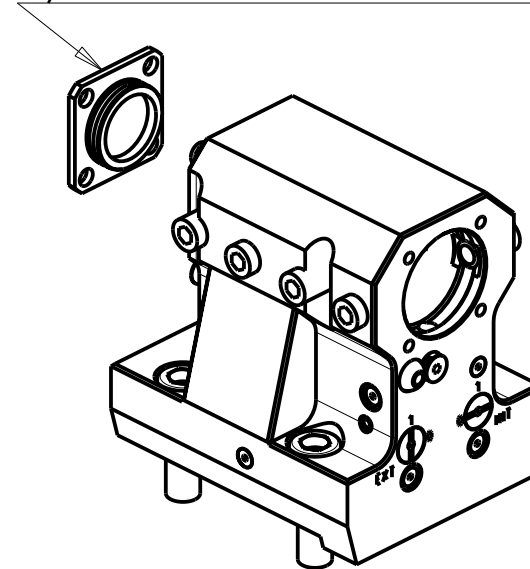

PER BOCCOLE DI RIDUZIONE VEDI PAG. TBL150-1-00
 FOR REDUCING BUSHINGS SEE PAGE TBL150-1-00
 FÜR REDUZIERBUCHSE SIEHE SEITE TBL150-1-00

Cod. MT	N°Utensili N°Tools N°Werkzeuge	Reversibile lato mandrino/contromandrino Reversible sub/main spindle side Umkehrbare Spindel-seite/ Gegenspindel-seite	Lubrificazione int. opzionale Coolant through optional Innenkuehlung Optional	Lubrificazione est. Ext. coolant Aussenkuehlung	Misure Dimensions Masse	D
OKU0133200	1		X	X	mm	32
OKU0133175	1	X	X	X	Inch	1 1/4"
OKU0134000	1	X	X	X	mm	40
OKU0133810	1	X	X	X	Inch	1 1/2"

OKUMA

MOD: LB2000EX - LB2500EX - LB3000EX - LU2000EX - LU2500EX - LU3000EX - MULTUS U3000/4000 2SW
 GENOS L300MW/MYW - GENOS L3000M

PORTAUTENSILE ASSIALE PER BARENO Ø32mm/Ø1 1/4"/Ø40mm/Ø1 1/2" H=90mm

Axial single boring bar holder Ø32mm/Ø1 1/4"/Ø40mm/Ø1 1/2" H=90mm

Axial Bohrhälter Ø32mm/Ø1 1/4"/Ø40mm/Ø1 1/2" H=90mm

Subject to change without notice.

M.T. srl

Via Casino Albini 480
 Tel. 0541/956034-957884
 Fax 0541/956341
 47842 S. GIOVANNI IN M. (RN)
 e-mail: mtma@mtmarchetti.com
 http://www.mtmarchetti.com

PRODUZIONE MODULI ROTANTI



PAGINA OKU630-4-10

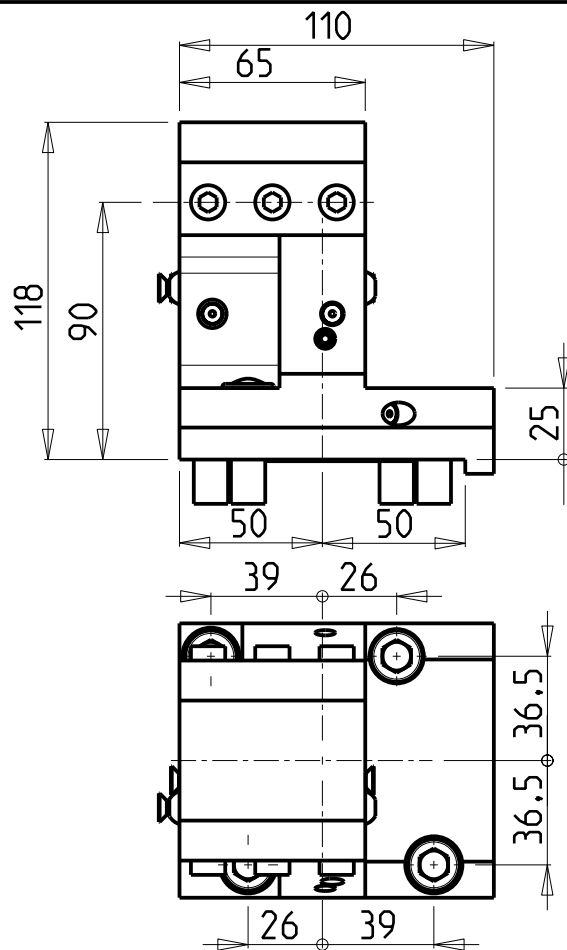
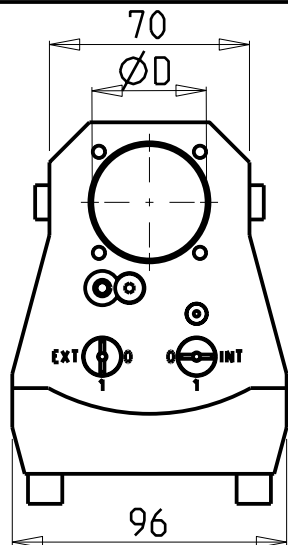

KIT ADDUZIONE INTERNA (OPZIONALE)
 KIT FOR INTERNAL COOLANT (OPTIONAL)
 KIT FUER INTERNE KUEHLMITTELZUFUHR (OPTIONAL)
 Ø40 cod. KIT1000019
 Ø1 1/2" cod. KIT1000023

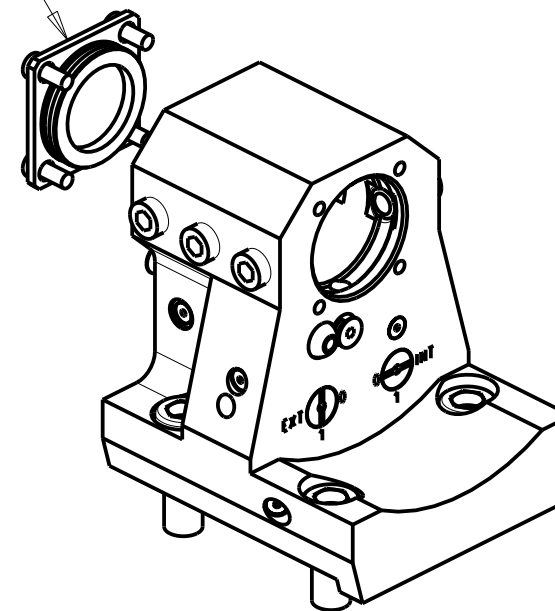

PER BOCCOLE DI RIDUZIONE VEDI PAG. TBL150-1-00
 FOR REDUCING BUSHINGS SEE PAGE TBL150-1-00
 FÜR REDUZIERBUCHSE SIEHE SEITE TBL150-1-00

Cod. MT	N°Utensili N°Tools N°Werkzeuge	Reversibile lato mandrino/contromandrino Reversible sub/main spindle side Umkehrbare Spindel-seite/ Gegenspindel-seite	Lubrificazione int. opzionale Coolant through optional Innenkuehlung Optional	Lubrificazione est. Ext. coolant Aussenkuehlung	Misure Dimensions Masse	D
OKU1144000	1	X	X	X	mm	40
OKU1143810	1	X	X	X	inch	1 1/2"

OKUMA
 MOD: LB2000EX - LB2500EX - LB3000EX - LU2000EX - LU2500EX - LU3000EX - MULTUS U3000/4000 2SW
 GENOS L300MW/MYW - GENOS L3000M

PORTAUTENSILE ASSIALE ARRETRATO PER BARENO Ø40mm / Ø1 1/2"
 Axial rear-set boring bar holder Ø40mm / Ø1 1/2"
 Axial Bohrhälter zurueckversetzt Ø40mm / Ø1 1/2"

Subject to change without notice.

M.T. srl
 Via Casino Albini 480
 Tel. 0541/956034-957884
 Fax 0541/956341
 47842 S. GIOVANNI IN M. (RN)
 e-mail: mtma@mtmarchetti.com
 http://www.mtmarchetti.com

PRODUZIONE MODULI ROTANTI



PAGINA OKU810-4-10

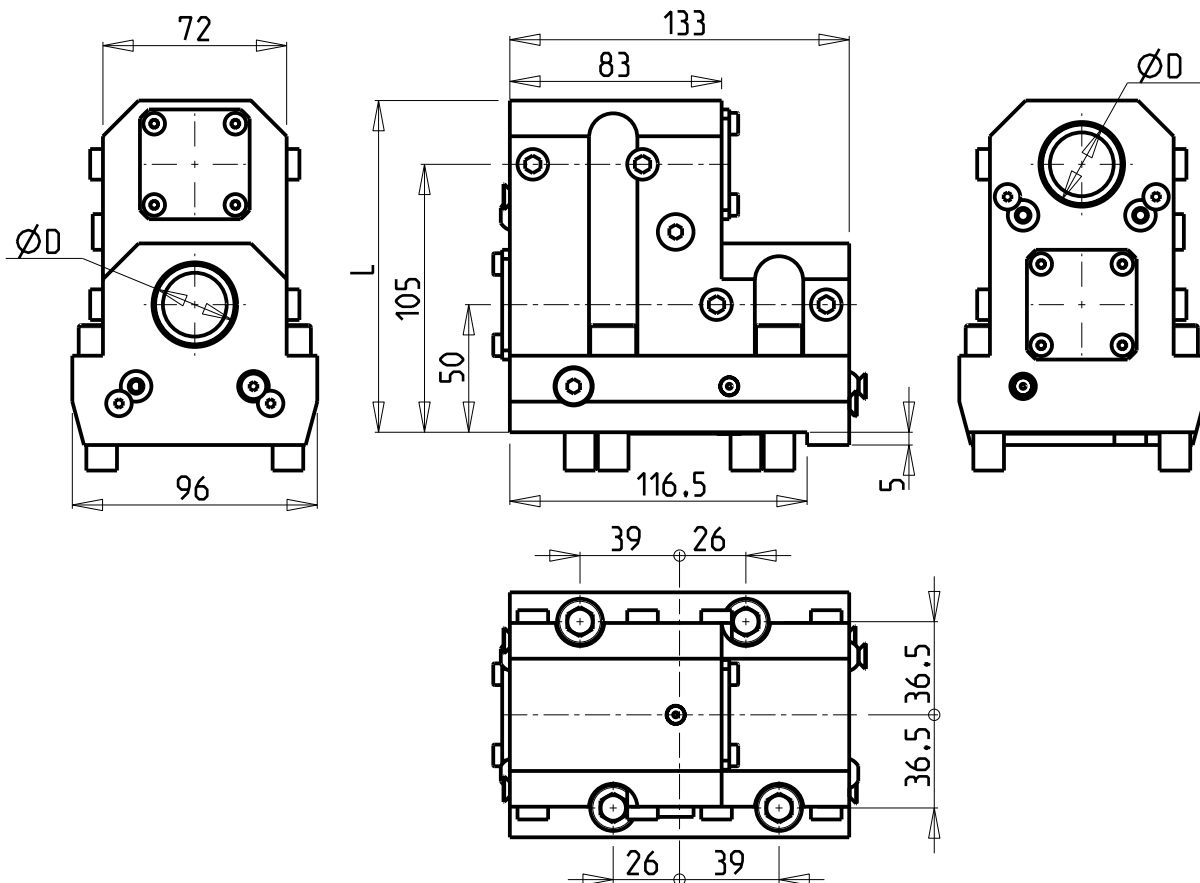

ATTENZIONE - ATTENTION - ACHTUNG

- VERIFICARE LE MISURE DI INGOMBRO PER POSSIBILE INTERFERENZA SU ALCUNI MODELLI DI MACCHINE
- Please check the overall sizes for possible interferences on some machine models
- Bitte überprüfen sie das ausmass um mögliche interferenzen auf einigen maschinen modellen zu vermeiden

KIT ADDUZIONE INTERNA (OPZIONALE)
 KIT FOR INTERNAL COOLANT (OPTIONAL)
 KIT FUER INTERNE KUEHLMITTELZUFUHR (OPTIONAL)
 $\varnothing 32$ - $\varnothing 1 \frac{1}{4}$ " cod. KIT1000020
 $\varnothing 40$ cod. KIT1000019
 $\varnothing 1 \frac{1}{2}$ " cod. KIT1000023

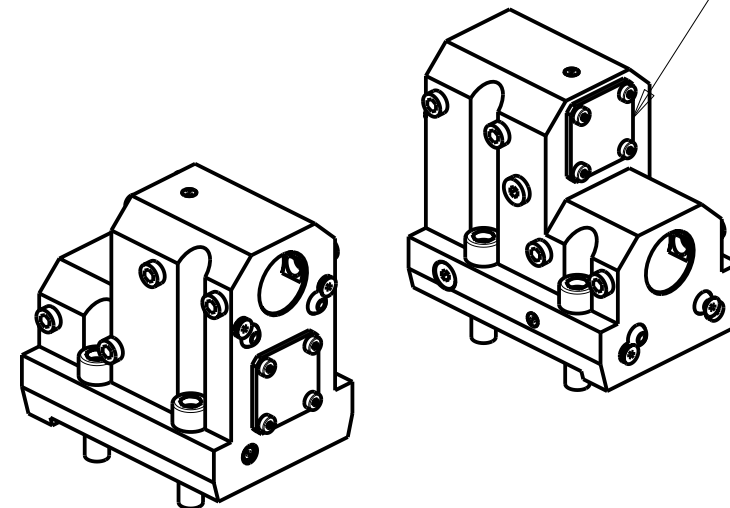

PER BOCCOLE DI RIDUZIONE VEDI PAG. TBL150-1-00
 FOR REDUCING BUSHINGS SEE PAGE TBL150-1-00
 FÜR REDUZIERBUCHSE SIEHE SEITE TBL150-1-00

Cod. MT	N°Utensili N°Tools N°Werkzeuge	Lubrificazione int. opzionale Coolant through optional Innenkuehlung Optional	Lubrificazione est. Ext. coolant Aussenkuehlung	Misure Dimensions Masse	D	L
OKU0143200	2	X	X	mm	32	130
OKU0143175	2	X	X	Inch	1 1/4"	130
OKU0144000	2	X	X	mm	40	134
OKU0143810	2	X	X	Inch	1 1/2"	134

OKUMA
 MOD: LB2000EX - LB2500EX - LB3000EX - LU2000EX - LU2500EX - LU3000EX - GENOS L300MW /MYW

PORTAUTENSILE ASSIALE PER BARENO 2 POSIZIONI $\varnothing 32$ mm/ $\varnothing 1 \frac{1}{4}$ "/ $\varnothing 40$ mm/ $\varnothing 1 \frac{1}{2}$ "
 Axial double boring bar holder $\varnothing 32$ mm/ $\varnothing 1 \frac{1}{4}$ "/ $\varnothing 40$ mm/ $\varnothing 1 \frac{1}{2}$ "
 Axial Bohrhälter 2 positionen $\varnothing 32$ mm/ $\varnothing 1 \frac{1}{4}$ "/ $\varnothing 40$ mm/ $\varnothing 1 \frac{1}{2}$ "

Subject to change without notice.

M.T. srl

Via Casino Albini 480
 Tel. 0541/956034-957884
 Fax 0541/956341
 47842 S. GIOVANNI IN M. (RN)
 e-mail: mtma@mtmarchetti.com
 http://www.mtmarchetti.com

PRODUZIONE MODULI ROTANTI



PAGINA OKU874-4-00

ATTENZIONE - ATTENTION - ACHTUNG

- VERIFICARE LE MISURE DI INGOMBRO PER POSSIBILE INTERFERENZA SU ALCUNI MODELLI DI MACCHINE
- Please check the overall sizes for possible interferences on some machine models
- Bitte überprüfen sie das ausmass um mögliche interferenzen auf einigen maschinen modellen zu vermeiden

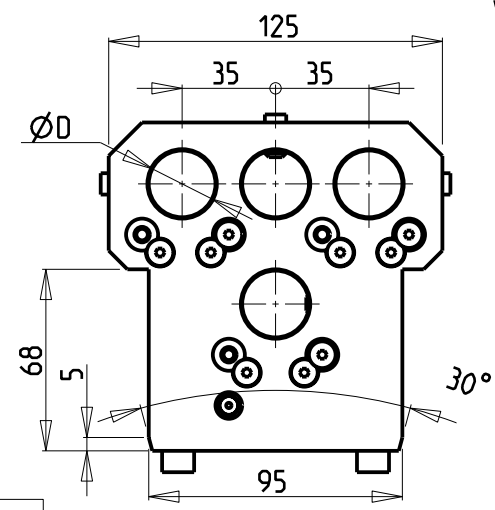
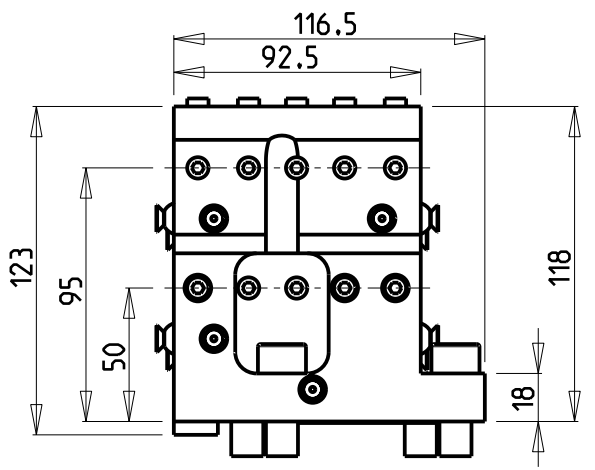
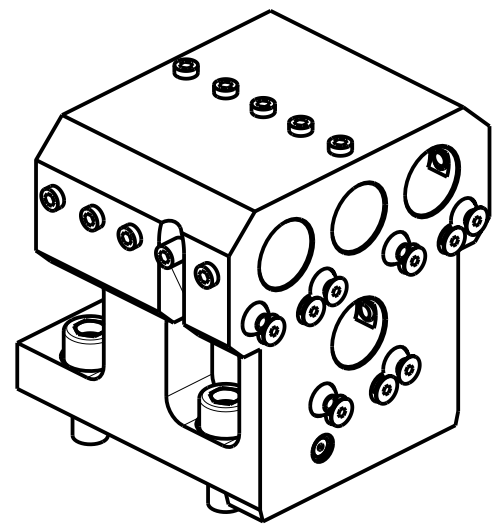
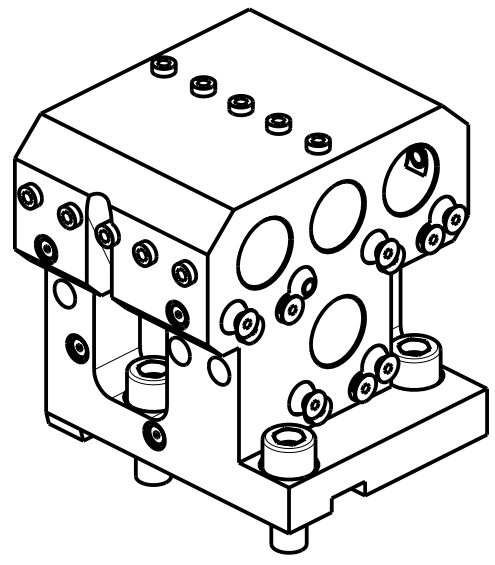
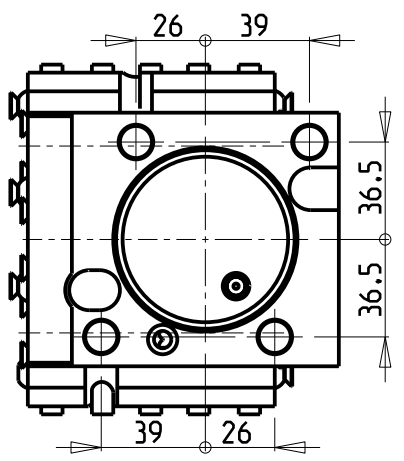

PER BOCCOLE DI RIDUZIONE VEDI PAG. TBL150-1-00
 FOR REDUCING BUSHINGS SEE PAGE TBL150-1-00
 FÜR REDUZIERBUCHSE SIEHE SEITE TBL150-1-00

Cod. MT	N°Utensili N°Tools N°Werkzeuge	Lubrificazione est. Ext. coolant Aussenkuehlung	Misure Dimensions Masse	D
OKU0192500	4+4	X	mm	25
OKU0192540	4+4	X	Inch	1"

OKUMA
 MOD: LB2000EX - LB2500EX - LB3000EX - LU2000EX - LU2500EX - LU3000EX - GENOS L300MW /MYW

PORTAUTENSILE ASSIALE PER BARENO 4+4 POSIZIONI Ø25mm
 Axial 4+4 position boring bar holder Ø25mm
 Axial Bohrhälter 4+4 positionen Ø25mm

Subject to change without notice.

M.T. srl
 Via Casino Albini 480
 Tel. 0541/956034-957884
 Fax 0541/956341
 47842 S. GIOVANNI IN M. (RN)
 e-mail: mtma@mtmarchetti.com
 http://www.mtmarchetti.com

PRODUZIONE MODULI ROTANTI



PAGINA OKU922-4-00

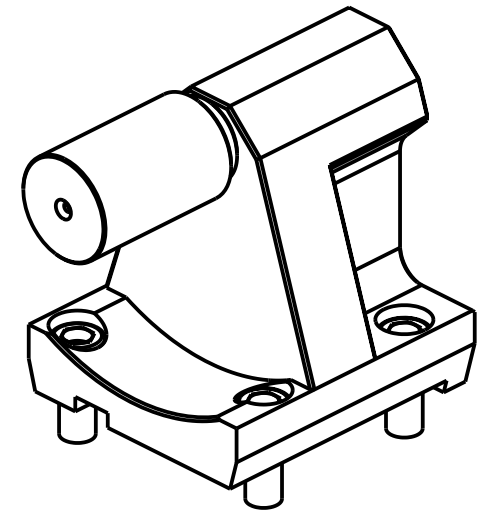
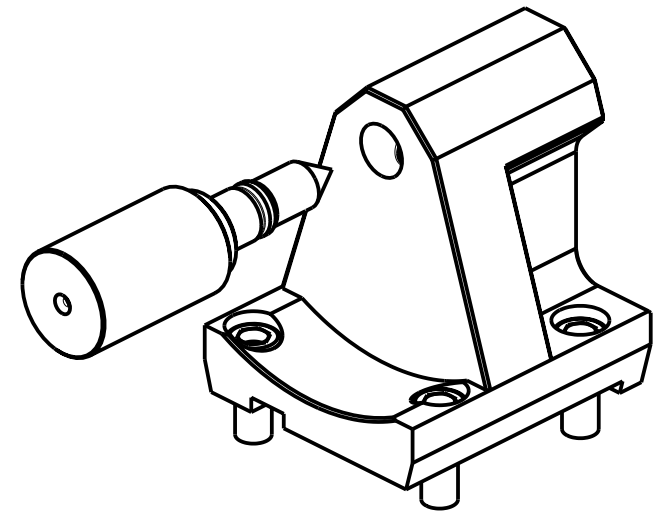
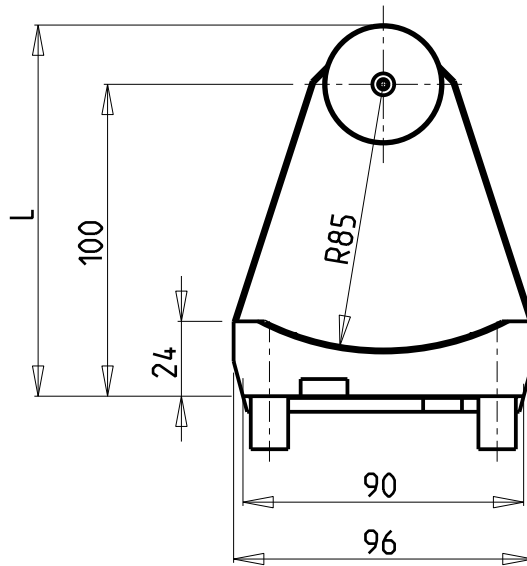
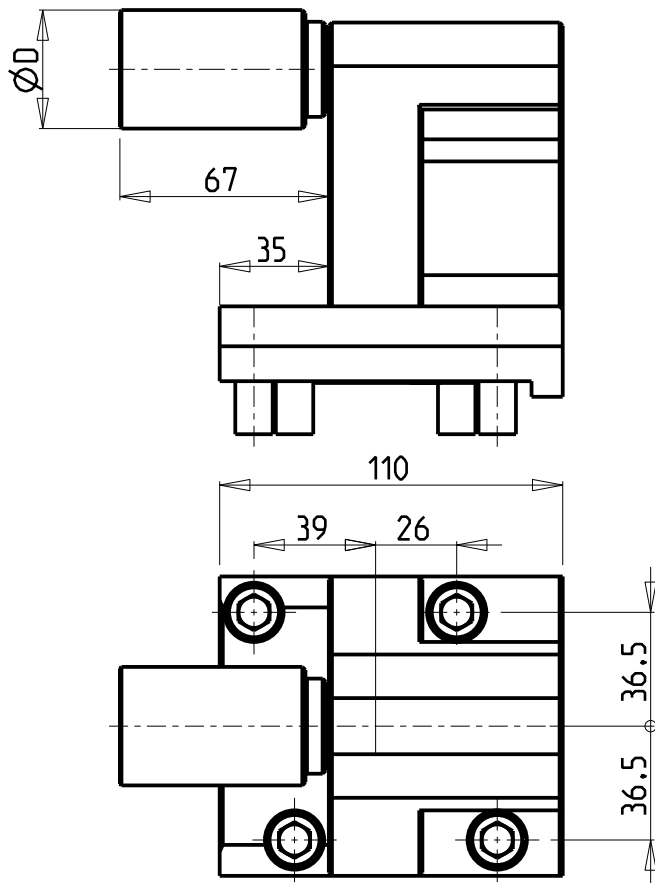

ATTENZIONE - ATTENTION - ACHTUNG

- VERIFICARE LE MISURE DI INGOMBRO PER POSSIBILE INTERFERENZA SU ALCUNI MODELLI DI MACCHINE
- Please check the overall sizes for possible interferences on some machine models
- Bitte überprüfen sie das ausmass um mögliche interferenzen auf einigen maschinen modellen zu vermeiden

Cod. MT	D	L
OKU1540100	38	119
OKU1540100L	2"	125.4

OKUMA
 MOD: LB2000EX - LB2500EX - LB3000EX - MULTUS U3000/4000 2SW - GENOS L300MW /MYW
 CONTROPUNTA PER CONTROMANDRINO
 Tailstock for subspindle
 Gegenspitz fuer Gegenspindel

M.T. srl
 Via Casino Albini 480
 Tel. 0541/956034-957884
 Fax 0541/956341
 47842 S. GIOVANNI IN M. (RN)
 e-mail: mtma@mtmarchetti.com
 http://www.mtmarchetti.com

PRODUZIONE MODULI ROTANTI



PAGINA OKU950-4-00

Subject to change without notice.

10/2018

