

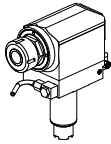

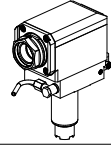
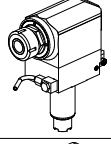
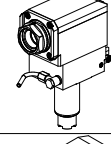
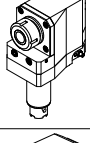
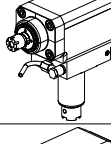
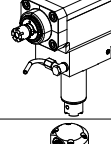
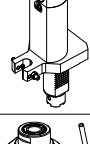
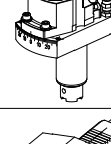
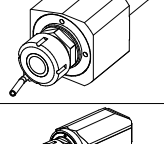
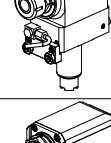

		PAGINA Page Seite
<p><b>MODULO MOTORIZZATO RADIALE VDI40 H=75 mm</b> Radial driven tool VDI40 H=75mm Radial angetriebenes Werkzeug VDI40 H=75mm</p>		OKU013.2.10
<p><b>MODULO MOTORIZZATO RADIALE MTSK VDI40 H=75mm</b> Radial MTSK driven tool VDI40 H=75mm Radial MTSK angetriebenes Werkzeug VDI40 H=75mm</p>		OKU013.2.10.K
<p><b>MODULO MOTORIZZATO RADIALE VDI40 H=90mm</b> Radial driven tool VDI40 H=90mm Radial angetriebenes Werkzeug VDI40 H=90mm</p>		OKU013.2.20
<p><b>MODULO MOTORIZZATO RADIALE MTSK VDI40 H=90mm</b> Radial MTSK driven tool VDI40 H=90mm Radial MTSK angetriebenes Werkzeug VDI40 H=90mm</p>		OKU013.2.20.K
<p><b>MODULO MOTORIZZATO RADIALE ARRETRATO VDI40</b> Radial rear-set driven tool VDI40 Radial angetriebenes Werkzeug zurueckversetzt VDI40</p>		OKU015.2.00
<p><b>MODULO MOTORIZZATO RADIALE MOLTIPLICATO I=1:3 VDI40 H=75mm</b> Radial geared-up I=1:3 driven tool VDI40 H=75mm Radial angetriebenes Werkzeug uebersetzt I=1:3 VDI40 H=75mm</p>		OKU018.2.14
<p><b>MODULO MOTORIZZATO RADIALE MOLTIPLICATO I=1:3 VDI40 H=90mm</b> Radial geared-up I=1:3 driven tool VDI40 H=90mm Radial angetriebenes Werkzeug uebersetzt I=1:3 VDI40 H=90mm</p>		OKU018.2.24
<p><b>MODULO MOTORIZZATO RADIALE VDI40 H=150mm</b> Radial driven tool VDI40 H=150mm Radial angetriebenes Werkzeug VDI40 H=150mm</p>		OKU125.2.00
<p><b>MODULO MOTORIZZ. ASSIALE DISASSATO 30mm ORIENTABILE ±30° VDI40</b> Axial ±30° adjustable angle driven tool re-directed by 30mm VDI40 Axial angetriebenes Werkzeug schwenkbar ±30° achsversetzt um 30mm VDI40</p>		OKU135.2.00
<p><b>MODULO MOTORIZZATO ASSIALE VDI40</b> Axial driven tool VDI40 Axial angetriebenes Werkzeug VDI40</p>		OKU150.2.00
<p><b>MODULO MOTORIZZATO ASSIALE VDI40 H=90mm</b> Axial driven tool VDI40 H=90mm Axial angetriebenes Werkzeug H=90mm</p>		OKU150.2.10
<p><b>MODULO MOTORIZZATO ASSIALE MTSK VDI40 H=90mm</b> Axial MTSK driven tool VDI40 H=90mm Axial MTSK angetriebenes Werkzeug VDI40 H=90mm</p>		OKU150.2.10.K

		PAGINA Page Seite
<p><b>MODULO MOTORIZZ. ASSIALE PER CONTROMANDRINO VD140 H=90mm</b> Axial driven tool for subspindle VD140 H=90mm Axial angetriebenes Werkzeug fuer Gegenspindel VD140 H=90mm</p>		OKU155.2.10
<p><b>MODULO MOTOR. ASSIALE MTSK PER CONTROMANDRINO VD140 H=90mm</b> Axial MTSK driven tool for subspindle VD140 H=90mm Axial MTSK angetriebenes Werkzeug fuer Gegenspindel VD140 H=90mm</p>		OKU155.2.10.K
<p><b>MODULO MOTORIZZATO ASSIALE DISASSATO VD140</b> Axial re-directed driven tool VD140 Axial angetriebenes Werkzeug achsversetzt VD140</p>		OKU160.2.00
<p><b>MODULO MOTORIZZATO ASSIALE RIDOTTO I=2:1 DISASSATO VD140</b> Axial geared-down I=2:1 driven tool re-directed VD140 Axial angetriebenes Werkzeug untersetzt I=2:1 achsversetzt VD140</p>		OKU160.2.10
<p><b>MODULO MOTORIZZ. ASSIALE MOLTIPLICATO I=1:2 DISASSATO 42mm VD140</b> Axial geared-up I=1:2 driven tool re-directed by 42mm VD140 Axial angetriebenes Werkzeug uebersetzt I=1:2 achsversetzt um 42mm VD140</p>		OKU160.2.20
<p><b>MODULO MOTORIZZATO ASSIALE MOLTIPLICATO I=1:3 VD140 H=90mm</b> Axial geared-up I=1:3 driven tool VD140 H=90mm Axial angetriebenes Werkzeug uebersetzt I=1:3 VD140 H=90mm</p>		OKU208.2.10
<p><b>MODULO MOT. ASSIALE PER CONTROMANDR. MOLTIPLICATO I=1:3 VD140 H=90mm</b> Axial geared-up I=1:3 driven tool for subspindle VD140 H=90mm Axial angetriebenes Werkzeug fuer Gegenspindel uebersetzt I=1:3 VD140 H=90mm</p>		OKU209.2.10
<p><b>MODULO MOTORIZZATO ASSIALE BISPORGENTE VD140</b> Axial opposite face driven tool VD140 Axial angetriebenes Werkzeug halb vorspringend VD140</p>		OKU240.2.10
<p><b>MODULO MOTORIZZATO ORIENTABILE ±90° VD140</b> ±90° adjustable angle driven tool VD140 Angetriebenes Werkzeug schwenkbar ±90° VD140</p>		OKU333.2.00
<p><b>MODULO MOTORIZZATO ORIENTABILE ±90° CON NONIO DIGITALE VD140</b> ±90° adjustable angle driven tool with digital display VD140 Angetriebenes Werkzeug schwenkbar ±90° mit digital display VD140</p>		OKU333.2.01
<p><b>MODULO MOTORIZZATO PORTACREATORE VD140</b> Driven gear hobber VD140 Angetriebenes Zahnradwaelzfraes-Werkzeug VD140</p>		OKU340.2.00
<p><b>MODULO MOTORIZZATO STOZZATORE CORSA 50mm VD140</b> Slotting driven tool 50mm stroke VD140 Keilnutenstossmaschine 50mm Hub VD140</p>		OKU360.2.30

		PAGINA Page Seite
<b>MODULO MOTORIZZATO STOZZATORE CORSA 25mm VDI40</b> Slotting driven tool 25mm stroke VDI40 Keilnutenstossmaschine 25mm Hub VDI40		OKU360.2.31

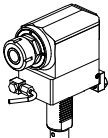
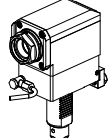
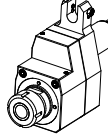
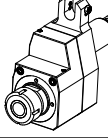

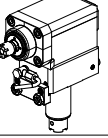
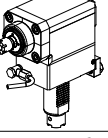
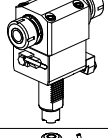
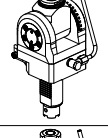
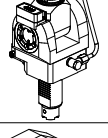
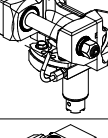
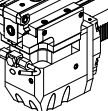
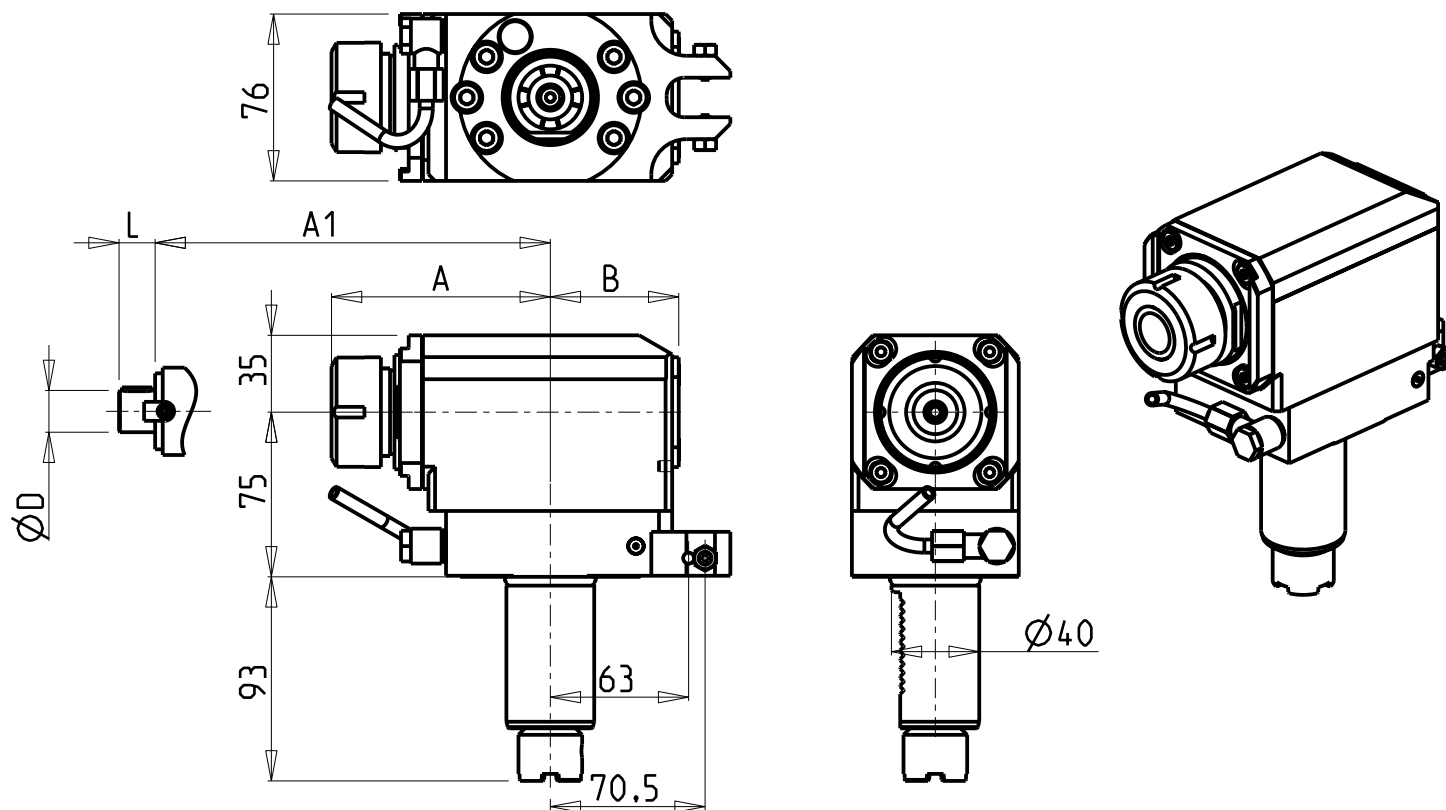

### ATTENZIONE - ATTENTION - ACHTUNG

- Per lo smontaggio degli utensili utilizzare sempre la chiave di contrasto come indicato nel manuale d'uso.
- For disassembly of the tools use always the contrast key as mentioned in the user instructions.
- Fuer das Abmontieren der Werkzeuge immer den Gegenschlüssel benutzen wie in der Bedienungsanleitung erwaeht.

### TORRETTE ASSIALI AXIAL TURRETS AXIAL REVOLVER

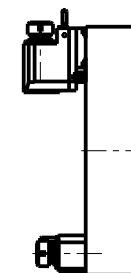

- Chiave inclusa
- Key included
- Schluessel inbegriffen

Cod. MT	Mandrino Spindle Spindel	I	RPM	Coppia Max Max Torque Max Drehmoment	Lubrificazione int. Coolant through Innenkuhlung	Lubrificazione est. Ext. coolant Aussenkuhlung	A	A1	B	D	L	CHIAVI NON INCLUDE Keys not included Schluessel nicht einbegriffen	
OKU0040132	ER32	1:1	4000	70Nm	-	X	99.7	-	58.5	-	-	OKU0650004	CHSTER32
OKU0040232	ER32	1:1	4000	70Nm	P=70bar	X	99.7	-	69.5	-	-	OKU0650004	CHSTER32
OKU0040140	ER40	1:1	4000	70Nm	-	X	103.7	-	58.5	-	-	OKU0650004	CHSTER40
OKU0040240	ER40	1:1	4000	70Nm	P=70bar	X	103.7	-	69.5	-	-	OKU0650004	CHSTER40
OKU0042219	Ø22x19	1:1	4000	70Nm	-	X	-	78.5	58.5	22	19	CHUB41	CH_VTCROCE_M10
OKU0042721	Ø27x21	1:1	4000	70Nm	-	X	-	78.5	58.5	27	21	CHUB41	CH_VTCROCE_M12

OKUMA

MOD: LB15/300 - LT15/300 - LR15 - LU15M - LU300M - GENOS L300M - ES L10M

MODULO MOTORIZZATO RADIALE VDI40 H=75mm

Radial driven tool VDI40 H=75mm

Radial angetriebenes Werkzeug VDI40 H=75mm

Subject to change without notice.

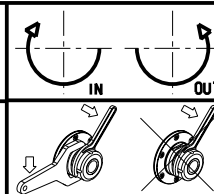

**M.T. srl**

Via Casino Albini 480  
Tel. 0541/956034-957884  
Fax 0541/956341  
47842 S. GIOVANNI IN M. (RN)  
e-mail: mtma@mtmarchetti.com  
http://www.mtmarchetti.com

PRODUZIONE MODULI ROTANTI



PAGINA OKU013-2-10

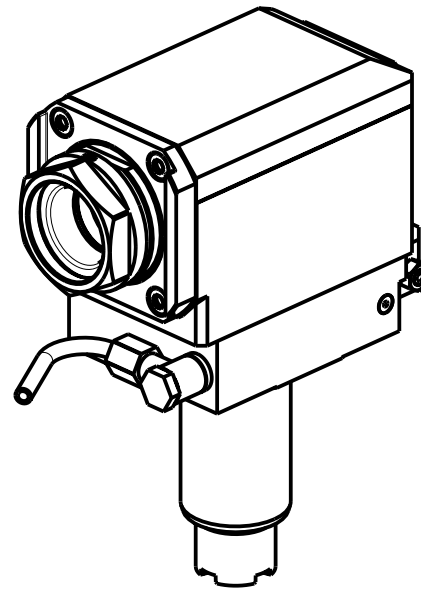
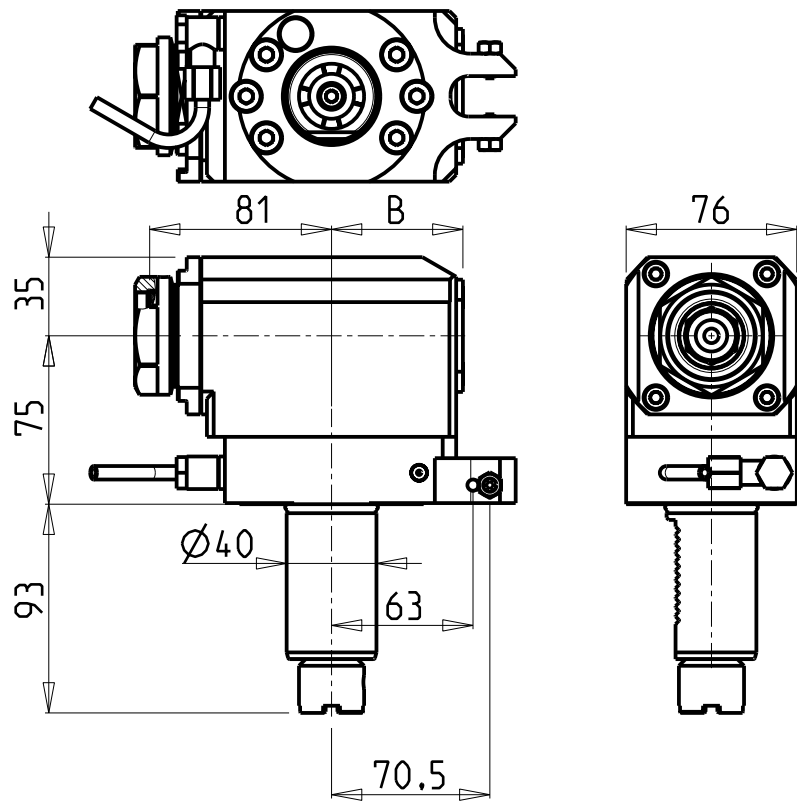

### ATTENZIONE - ATTENTION - ACHTUNG

- Per lo smontaggio degli utensili utilizzare sempre la chiave di contrasto come indicato nel manuale d'uso.
- For disassembly of the tools use always the contrast key as mentioned in the user instructions.
- Fuer das Abmontieren der Werkzeuge immer den Gegenschlüssel benutzen wie in der Bedienungsanleitung erwaeht.

### TORRETTE ASSIALI AXIAL TURRETS AXIAL REVOLVER

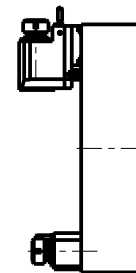

PER PORTAUTENSILI MODULARI MTSK-40 VEDI PAG. TBL300-1-40  
FOR MTSK-40 QUICK CHANGE TOOLHOLDERS CLAMPINGS SEE PAGE TBL300-1-40  
FUER MTSK-40 MODULARE WERKZEUGAUFNAHMEN SIEHE SEITE TBL300-1-40

Cod. MT	Mandrino Spindle Spindel	I	RPM	Coppia Max Max Torque Max Drehmoment	Lubrificazione int. Coolant through Innenkuehlung	Lubrificazione est. Ext. coolant Aussenkuehlung	B	CHIAVI NON INCLUSE Keys not included Schluesssel nicht einbegriffen	
OKU0840140	MTSK-40	1:1	4000	70Nm	-	X	58.5	CHUB46	OKU0650004
OKU0840240	MTSK-40	1:1	4000	70Nm	P=70bar	X	69.5	CHUB46	OKU0650004

- Chiave inclusa
- Key included
- Schluesssel inbegriffen

OKUMA  
MOD: LB15/300 - LT15/300 - LR15 - LU15M - LU300M - GENOS L300M - ES L10M

MODULO MOTORIZZATO RADIALE MTSK VDI40 H=75mm  
Radial MTSK driven tool VDI40 H=75mm  
Radial MTSK angetriebenes Werkzeug VDI40 H=75mm

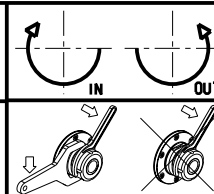

**M.T. srl**  
Via Casino Albini 480  
Tel. 0541/956034-957884  
Fax 0541/956341  
47842 S. GIOVANNI IN M. (RN)  
e-mail: mtma@mtmarchetti.com  
http://www.mtmarchetti.com

PRODUZIONE MODULI ROTANTI



PAGINA OKU013-2-10-K

Subject to change without notice.

10/2018

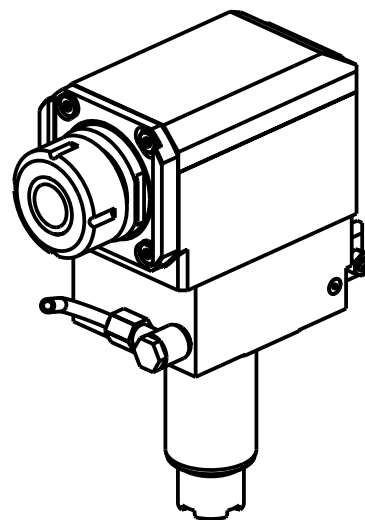
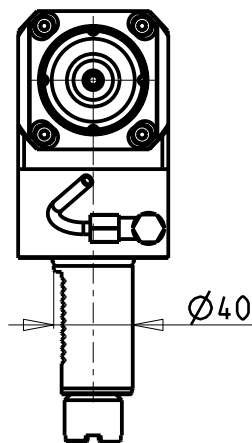
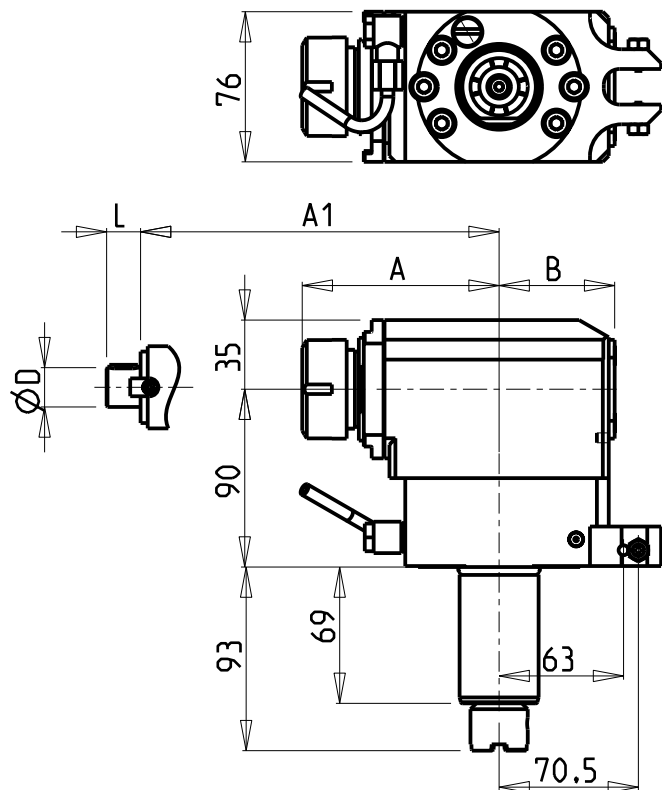

### ATTENZIONE - ATTENTION - ACHTUNG

- Per lo smontaggio degli utensili utilizzare sempre la chiave di contrasto come indicato nel manuale d'uso.
- For disassembly of the tools use always the contrast key as mentioned in the user instructions.
- Fuer das Abmontieren der Werkzeuge immer den Gegenschlüssel benutzen wie in der Bedienungsanleitung erwaeht.

### TORRETTE ASSIALI AXIAL TURRETS AXIAL REVOLVER

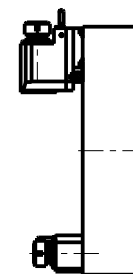

- Chiave inclusa
- Key included
- Schluessel inbegriffen

Cod. MT	Mandrino Spindle Spindel	I	RPM	Coppia Max Max Torque Max Drehmoment	Lubrificazione int. Coolant through Innenkuhlung	Lubrificazione est. Ext. coolant Aussenkuhlung	A	A1	B	D	L	CHIAVI NON INCLUDE Keys not included Schluessel nicht einbegriffen	
OKU0050132	ER32	1:1	4000	70Nm	-	X	99.7	-	58.5	-	-	OKU0650004	CHSTER32
OKU0050232	ER32	1:1	4000	70Nm	P=70bar	X	99.7	-	69.5	-	-	OKU0650004	CHSTER32
OKU0050140	ER40	1:1	4000	70Nm	-	X	103.7	-	58.5	-	-	OKU0650004	CHSTER40
OKU0050240	ER40	1:1	4000	70Nm	P=70bar	X	103.7	-	69.5	-	-	OKU0650004	CHSTER40
OKU0052219	Ø22x19	1:1	4000	70Nm	-	X	-	78.5	58.5	22	19	CHUB41	CH_VTCROCE_M10
OKU0052721	Ø27x21	1:1	4000	70Nm	-	X	-	78.5	58.5	27	21	CHUB41	CH_VTCROCE_M12

OKUMA  
MOD: LB15/300 - LT15/300 - LR15 - LU15M - LU300M - GENOS L300M - ES L10M

MODULO MOTORIZZATO RADIALE VDI40 H=90mm  
Radial driven tool VDI40 H=90mm  
Radial angetriebenes Werkzeug VDI40 H=90mm

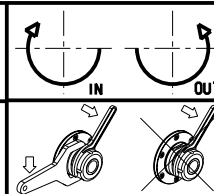

**M.T. srl**  
Via Casino Albini 480  
Tel. 0541/956034-957884  
Fax 0541/956341  
47842 S. GIOVANNI IN M. (RN)  
e-mail: mtma@mtmarchetti.com  
http://www.mtmarchetti.com

PRODUZIONE MODULI ROTANTI



PAGINA OKU013-2-20

Subject to change without notice.

10/2018

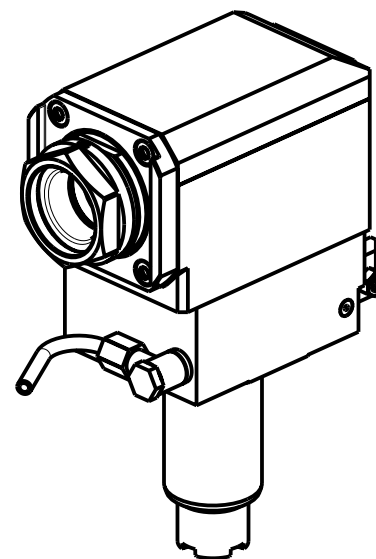
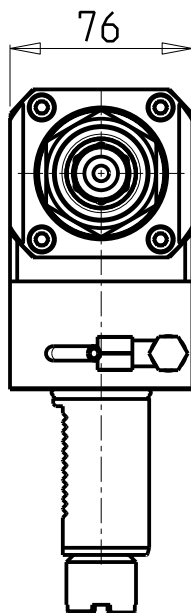
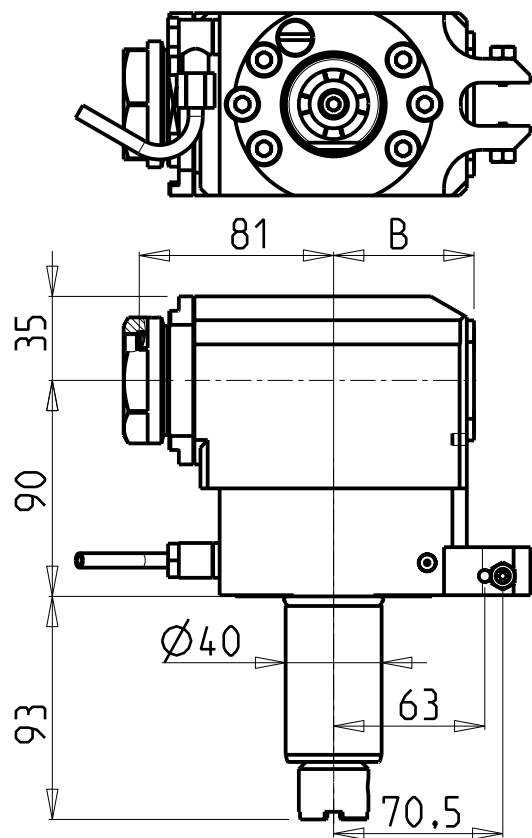

### ATTENZIONE - ATTENTION - ACHTUNG

- Per lo smontaggio degli utensili utilizzare sempre la chiave di contrasto come indicato nel manuale d'uso.
- For disassembly of the tools use always the contrast key as mentioned in the user instructions.
- Fuer das Abmontieren der Werkzeuge immer den Gegenschlüssel benutzen wie in der Bedienungsanleitung erwaeht.

### TORRETTE ASSIALI AXIAL TURRETS AXIAL REVOLVER

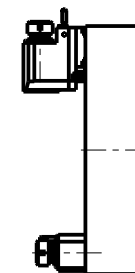

PER PORTAUTENSILI MODULARI MTSK-40 VEDI PAG. TBL300-1-40  
FOR MTSK-40 QUICK CHANGE TOOLHOLDERS CLAMPINGS SEE PAGE TBL300-1-40  
FUER MTSK-40 MODULARE WERKZEUGAUFNAHMEN SIEHE SEITE TBL300-1-40

Cod. MT	Mandrino Spindle Spindel	I	RPM	Coppia Max Max Torque Max Drehmoment	Lubrificazione int. Coolant through Innenkuehlung	Lubrificazione est. Ext. coolant Aussenkuehlung	B	CHIAVI NON INCLUDE Keys not included Schluesssel nicht einbegriffen	
OKU0850140	MTSK-40	1:1	4000	70Nm	-	X	58.5	CHUB46	OKU0650004 ■
OKU0850240	MTSK-40	1:1	4000	70Nm	P=70bar	X	69.5	CHUB46	OKU0650004 ■

- Chiave inclusa
- Key included
- Schluesssel inbegriffen

OKUMA  
MOD: LB15/300 - LT15/300 - LR15 - LU15M - LU300M - GENOS L300M - ES L10M

MODULO MOTORIZZATO RADIALE MTSK VDI40 H=90mm  
Radial MTSK driven tool VDI40 H=90mm  
Radial MTSK angetriebenes Werkzeug VDI40 H=90mm

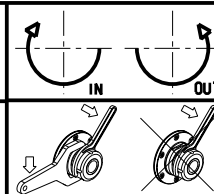

**M.T. srl**  
Via Casino Albini 480  
Tel. 0541/956034-957884  
Fax 0541/956341  
47842 S. GIOVANNI IN M. (RN)  
e-mail: mtma@mtmarchetti.com  
http://www.mtmarchetti.com

PRODUZIONE MODULI ROTANTI



PAGINA OKU013-2-20-K

Subject to change without notice.

10/2018



**ATTENZIONE - ATTENTION - ACHTUNG**

- Per lo smontaggio degli utensili utilizzare sempre la chiave di contrasto come indicato nel manuale d'uso.
- For disassembly of the tools use always the contrast key as mentioned in the user instructions.
- Fuer das Abmontieren der Werkzeuge immer den Gegenschlüssel benutzen wie in der Bedienungsanleitung erwaeht.

**TORRETTE ASSIALI  
AXIAL TURRETS  
AXIAL REVOLVER**

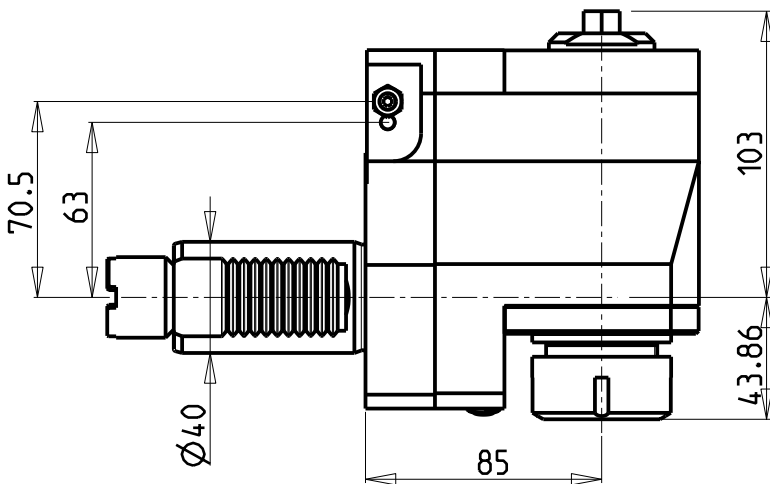
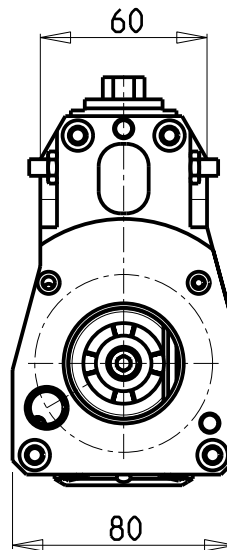
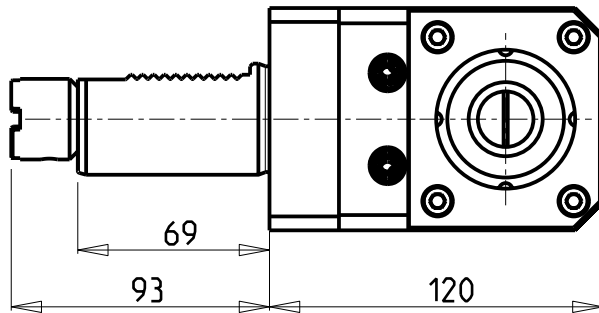
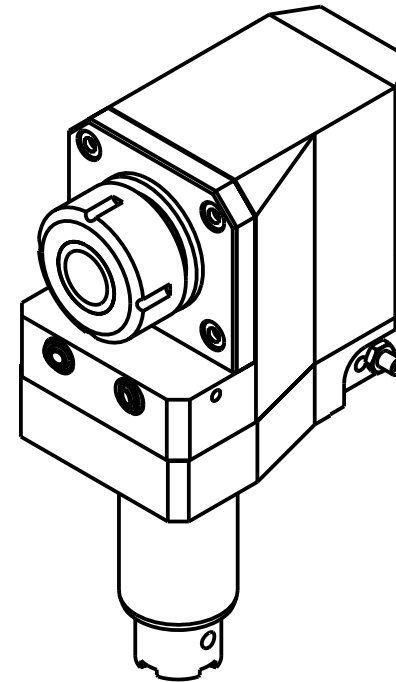
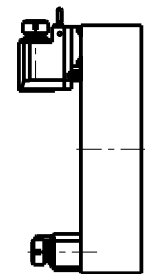

Cod. MT	Mandrino Spindle Spindel	I	RPM	Coppia Max Max Torque Max Drehmoment	Lubrificazione est. Ext. coolant Aussenkuehlung	CHIAVI NON INCLUSE Keys not included Schlüssel nicht einbegriffen	
1210KU_R32_40B00	ER32	1:1	4000	70Nm	X	CHUB13	CHSTER32

**OKUMA**  
MOD: LB15/300 - LT15/300 - LR15 - LU15M - LU300M - GENOS L300M - ES L10M

MODULO MOTORIZZATO RADIALE ARRETRATO VD140  
Radial rear-set driven tool VD140  
Radial angetriebenes Werkzeug zurueckversetzt VD140

Subject to change without notice.

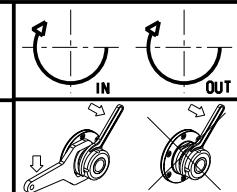

**M.T. srl**  
Via Casino Albini 480  
Tel. 0541/956034-957884  
Fax 0541/956341  
47842 S. GIOVANNI IN M. (RN)  
e-mail: mtma@mtmarchetti.com  
http://www.mtmarchetti.com

PRODUZIONE MODULI ROTANTI



PAGINA OKU015-2-00

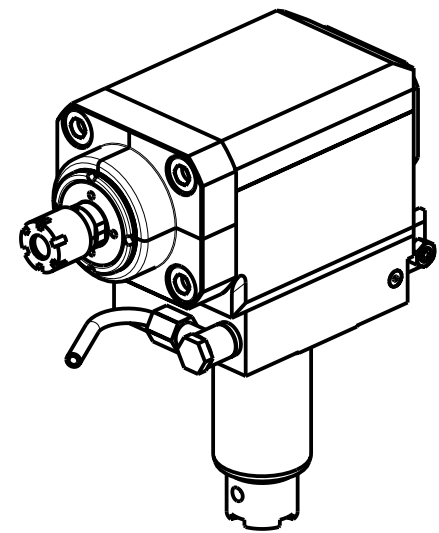
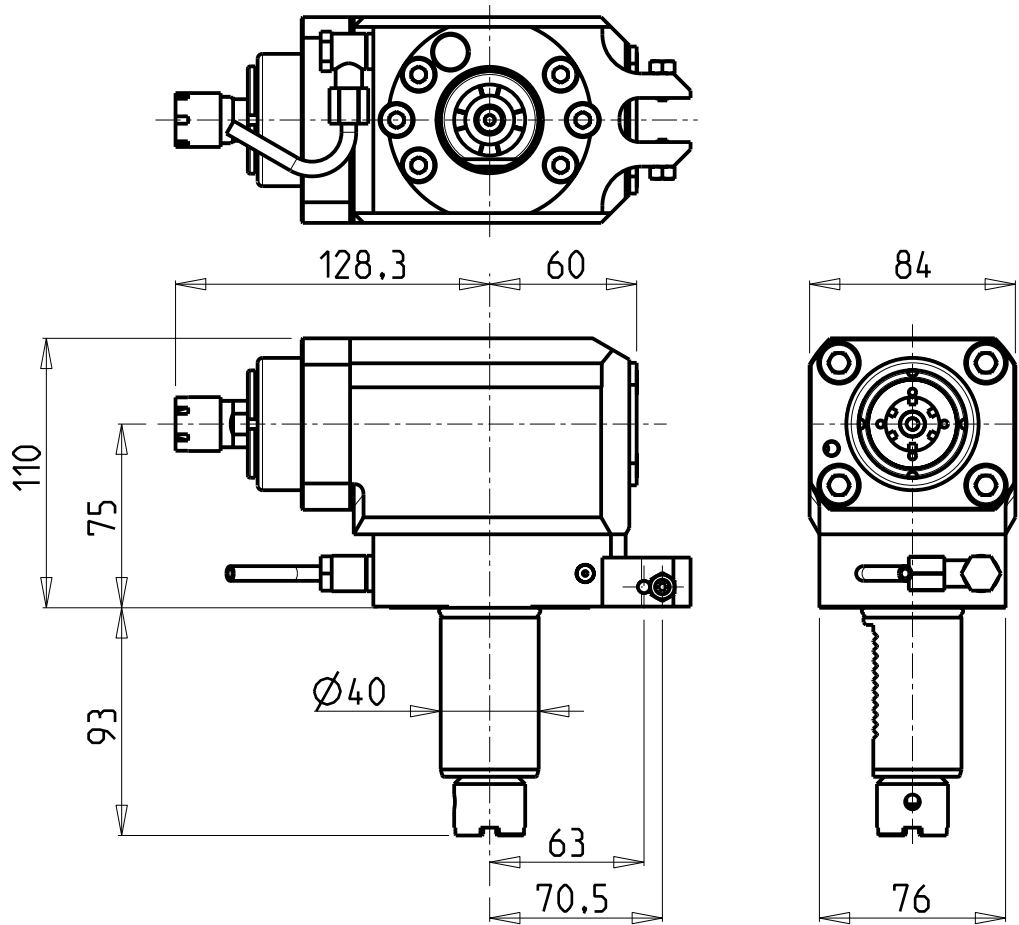

**ATTENZIONE - ATTENTION - ACHTUNG**

- Per lo smontaggio degli utensili utilizzare sempre la chiave di contrasto come indicato nel manuale d'uso.
- For disassembly of the tools use always the contrast key as mentioned in the user instructions.
- Fuer das Abmontieren der Werkzeuge immer den Gegenschlüssel benutzen wie in der Bedienungsanleitung erwäehnt.

**TORRETTE ASSIALI  
AXIAL TURRETS  
AXIAL REVOLVER**

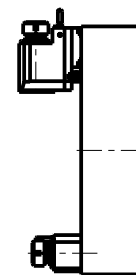

Cod. MT	Mandrino Spindle Spindel	I	RPM	Coppia Max Max Torque Max Drehmoment	Lubrificazione est. Ext. coolant Aussenkuehlung	CHIAVI INCLUSE Keys included Schluessel einbegriffen
OKU1290016	ER16	1:3	12000	10Nm	X	CHUB17 CHMNER16

**OKUMA**  
 MOD: LB15/300 - LT15/300 - LR15 - LU15M - LU300M - GENOS L300M - ES L10M

MODULO MOTORIZZATO RADIALE MOLTIPLICATO I=1:3 VDI40 H=75mm  
 Radial geared-up I=1:3 driven tool VDI40 H=75mm  
 Radial angetriebenes Werkzeug uebersetzt I=1:3 VDI40 H=75mm

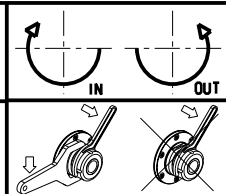

**M.T. srl**  
 Via Casino Albini 480  
 Tel. 0541/956034-957884  
 Fax 0541/956341  
 47842 S. GIOVANNI IN M. (RN)  
 e-mail: mtma@mtmarchetti.com  
 http://www.mtmarchetti.com

PRODUZIONE MODULI ROTANTI



PAGINA OKU018-2-14

Subject to change without notice.

10/2018

**ATTENZIONE - ATTENTION - ACHTUNG**

- Per lo smontaggio degli utensili utilizzare sempre la chiave di contrasto come indicato nel manuale d'uso.
- For disassembly of the tools use always the contrast key as mentioned in the user instructions.
- Fuer das Abmontieren der Werkzeuge immer den Gegenschlüssel benutzen wie in der Bedienungsanleitung erwaeht.

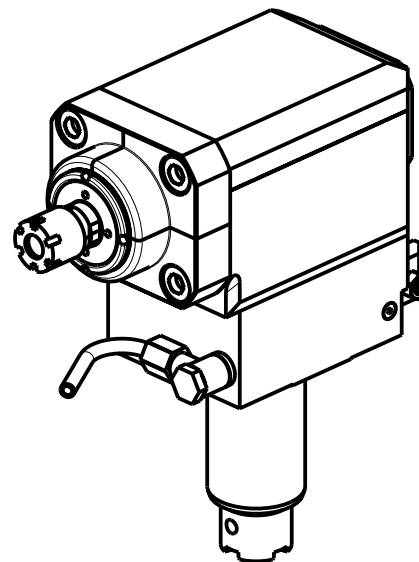
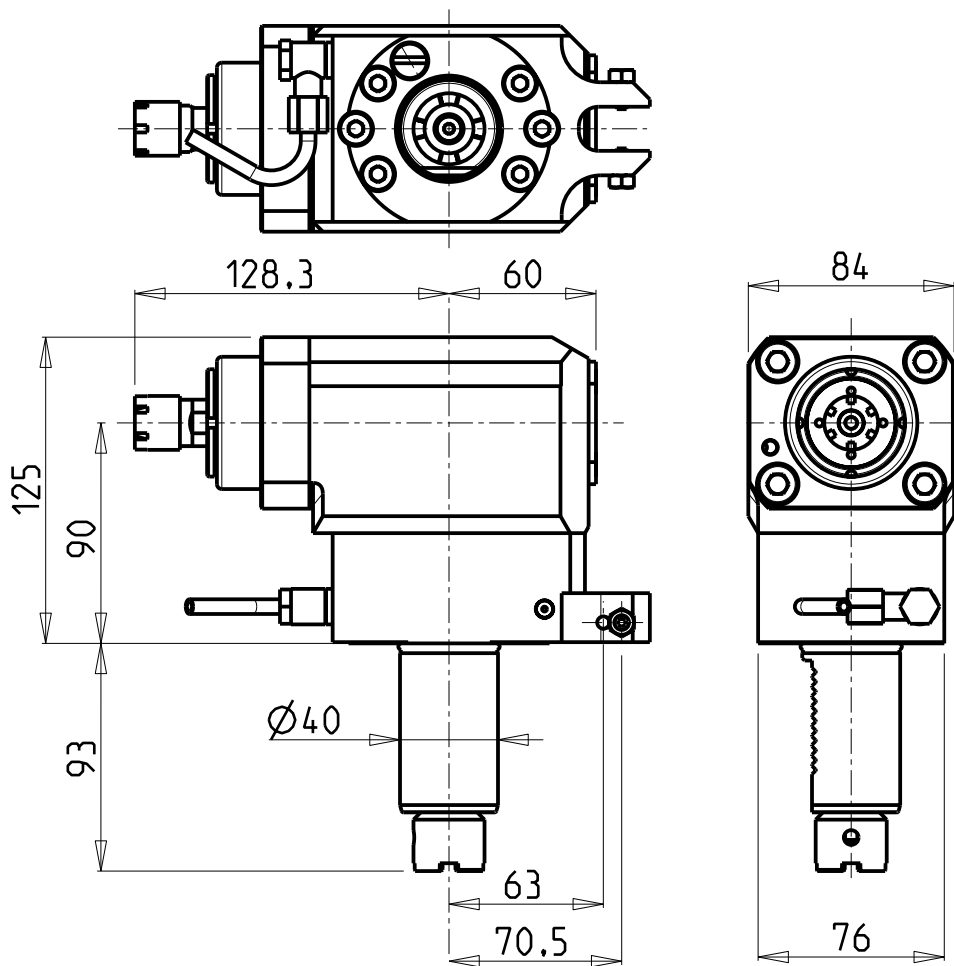

**TORRETTE ASSIALI  
AXIAL TURRETS  
AXIAL REVOLVER**

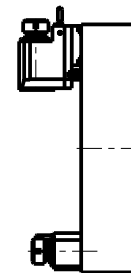

Cod. MT	Mandrino Spindle Spindel	I	RPM	Coppia Max Max Torque Max Drehmoment	Lubrificazione est. Ext. coolant Aussenkuehlung	CHIAVI INCLUSE Keys included Schluessel einbegriffen
OKU1300016	ER16	1:3	12000	10Nm	X	CHUB17 CHMNER16

**OKUMA**  
 MOD: LB15/300 - LT15/300 - LR15 - LU15M - LU300M - GENOSL300M - ES L10M

MODULO MOTORIZZATO RADIALE Moltiplicato I=1:3 VDI40 H=90mm  
 Radial geared-up I=1:3 driven tool VDI40 H=90mm  
 Radial angetriebenes Werkzeug uebersetzt I=1:3 VDI40 H=90mm

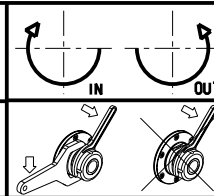

**M.T. srl**  
 Via Casino Albini 480  
 Tel. 0541/956034-957884  
 Fax 0541/956341  
 47842 S. GIOVANNI IN M. (RN)  
 e-mail: mtma@mtmarchetti.com  
 http://www.mtmarchetti.com

PRODUZIONE MODULI ROTANTI



PAGINA OKU018-2-24

Subject to change without notice.

10/2018

PER LAVORAZIONI INTERNE  
SU FORI Ø65 MINIMO

For machining internal  
holes with Ø65 min. hole

Fuer interne Bearbeitungen  
am loch minimum Ø65

**ATTENZIONE - ATTENTION - ACHTUNG**

- Per lo smontaggio degli utensili utilizzare sempre la chiave di contrasto come indicato nel manuale d'uso.
- For disassembly of the tools use always the contrast key as mentioned in the user instructions.
- Fuer das Abmontieren der Werkzeuge immer den Gegenschlüssel benutzen wie in der Bedienungsanleitung erwaeht.

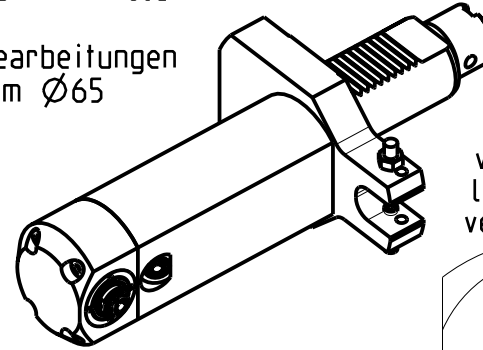
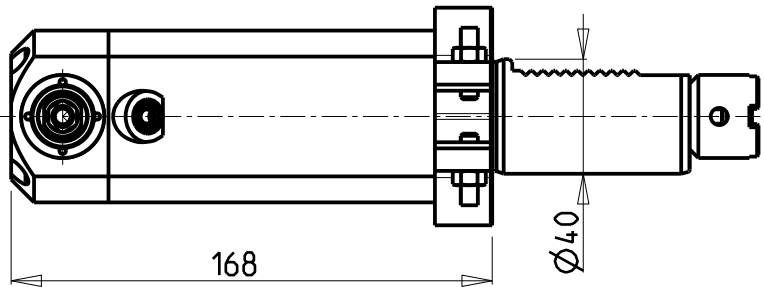

versione sx  
left version  
version links

versione dx  
right version  
version rechts

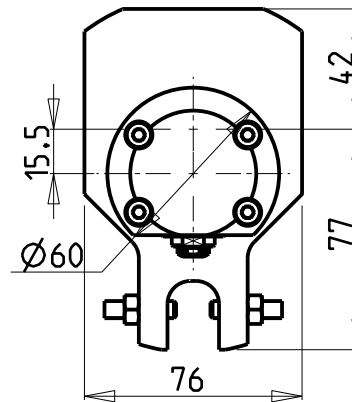
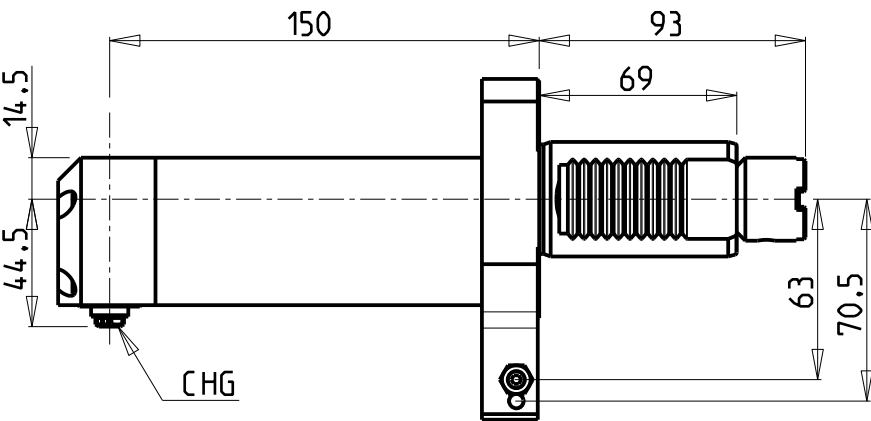
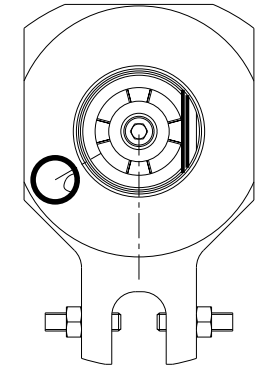
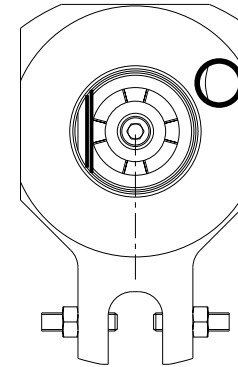

**TORRETTE ASSIALI  
AXIAL TURRETS  
AXIAL REVOLVER**

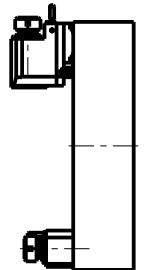

Cod. MT		Mandrino Spindle Spindel	I	RPM	Coppia Max Max Torque Max Drehmoment	Lubrificazione est. Ext. coolant Aussenkuehlung	CHIAVI INCLUSE Keys included Schlüssel einbegriffen	
versione sx left version version links	versione dx right version version rechts						CHUB13	CHCHG10
1270KU_R10_40B00	1270KU_R10_40B10	CHG	1:1	4000	10Nm	X	CHUB13	CHCHG10

OKUMA  
MOD: LB15/300 - LT15/300 - LR15 - LU15M - LU300M - GENOS L300M - ES L10M

MODULO MOTORIZZATO RADIALE VDI40 H=150mm  
Radial driven tool VDI40 H=150mm  
Radial angetriebenes Werkzeug VDI40 H=150mm

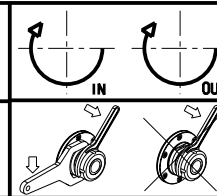

**M.T. srl**  
Via Casino Albini 480  
Tel. 0541/956034-957884  
Fax 0541/956341  
47842 S. GIOVANNI IN M. (RN)  
e-mail: mtma@mtmarchetti.com  
http://www.mtmarchetti.com

PRODUZIONE MODULI ROTANTI



PAGINA OKU125-2-00

Subject to change without notice.

10/2018

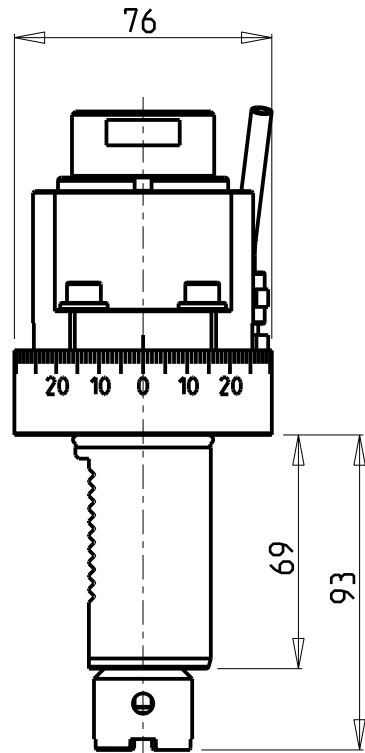
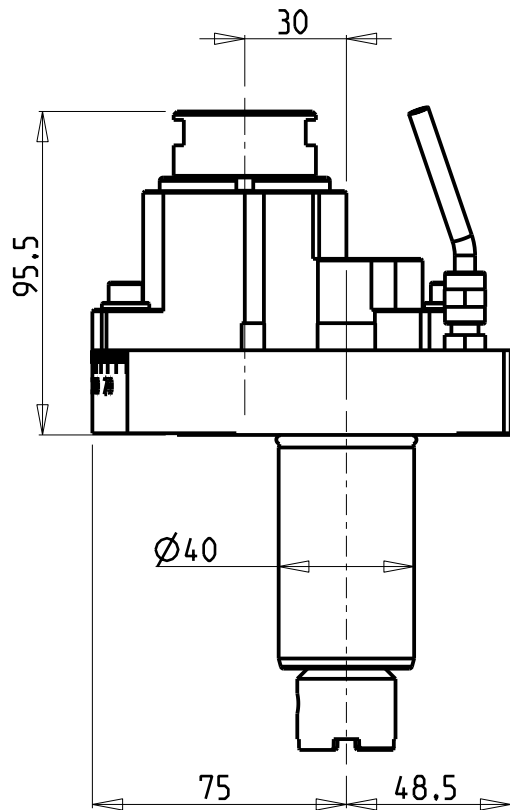

TORRETTE ASSIALI  
AXIAL TURRETS  
AXIAL REVOLVER

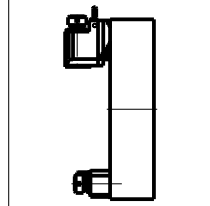

TORRETTE RADIALI  
RADIAL TURRETS  
RADIAL REVOLVER

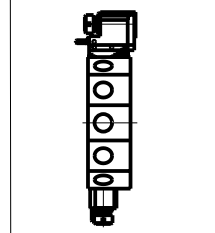

**ATTENZIONE - ATTENTION - ACHTUNG**

- Per lo smontaggio degli utensili utilizzare sempre la chiave di contrasto come indicato nel manuale d'uso.
- For disassembly of the tools use always the contrast key as mentioned in the user instructions.
- Fuer das Abmontieren der Werkzeuge immer den Gegenschlüssel benutzen wie in der Bedienungsanleitung erwäehnt.

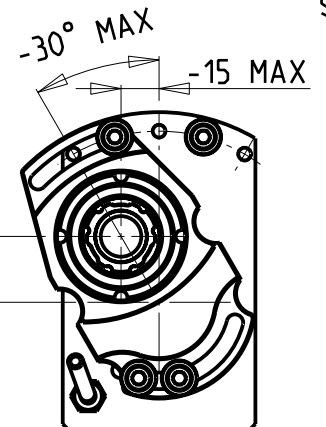
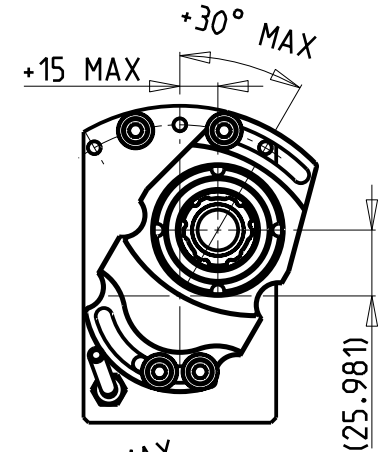
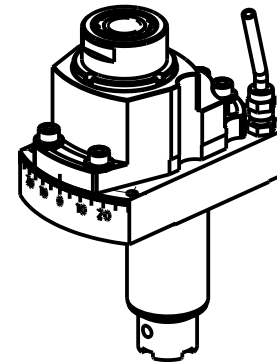
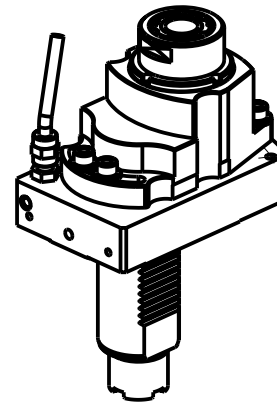

• Chiave inclusa

• Key included

• Schluessel inbegriffen

CHIAVI NON INCLUSE  
Keys not included  
Schluessel nicht einbegriffen

Cod. MT	Mandrino Spindle Spindel	I	RPM	Coppia Max Max Torque Max Drehmoment	Lubrificazione est. Ext. coolant Aussehenkuehlung	CHIAVI NON INCLUSE Keys not included Schluessel nicht einbegriffen		
OKU1590325	ERA25	1:1	4000	40Nm	X	CHUB36	CHUB27	CHTAER25ZC •

OKUMA

MOD: LB15/300 - LT15/300 - LR15 - LU15M - LU300M - GENOS L300M - MACTURN 250/350/550 - ES L10M

MODULO MOTORIZZATO ASSIALE DISASSATO 30mm ORIENTABILE ±30° VDI40

Axial ±30° adjustable angle driven tool re-directed by 30mm VDI40

Axial angetriebenes Werkzeug schwenkbar ±30° achsversetzt um 30mm VDI40

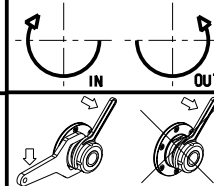

**M.T. srl**

Via Casino Albini 480  
Tel. 0541/956034-957884  
Fax 0541/956341

47842 S. GIOVANNI IN M. (RN)  
e-mail: mtma@mtmarchetti.com  
http://www.mtmarchetti.com

PRODUZIONE MODULI ROTANTI



PAGINA OKU135-2-00

Subject to change without notice.

10/2018

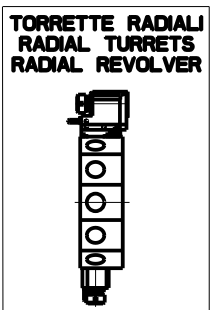
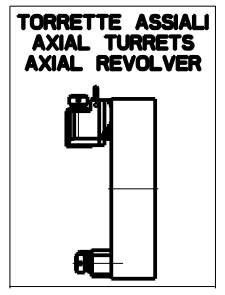
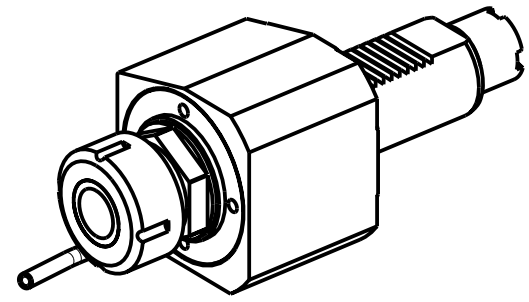
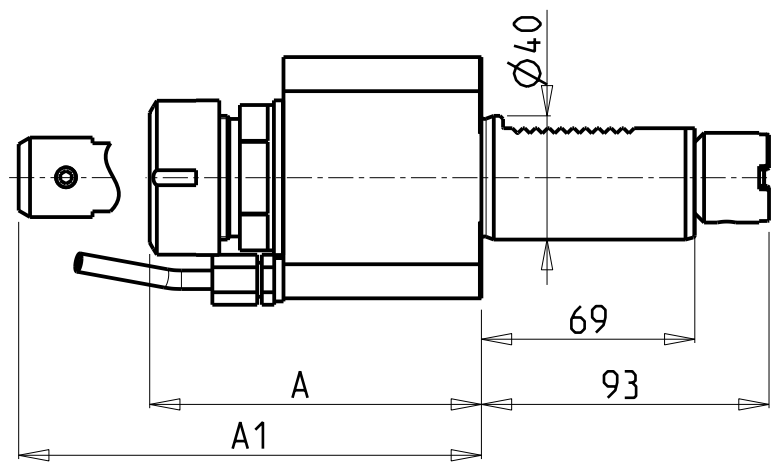
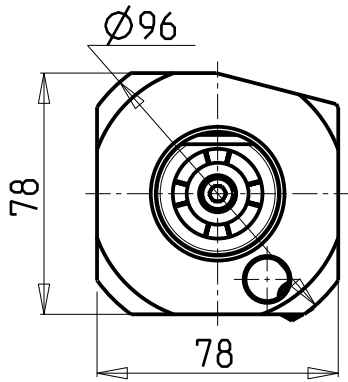

Cod. MT	Mandrino Spindle Spindel	I	RPM	Coppia Max Max Torque Max Drehmoment	Lubrificazione est. Ext. coolant Aussenkuehlung	Lubrificazione int. Coolant through Innenkuehlung	A	A1	CHIAVI NON INCLUSE Keys not included Schluessel nicht einbegriffen	
									CHUB41	CHSTER32
1220KU_A32_40B00	ER32	1:1	4000	70Nm	X	-	107.3	-	CHUB41	CHSTER32
OKU1210232	ER32	1:1	4000	70Nm	X	P=30bar	110.5	-	CHUB41	CHSTER32
OKU1210240	ER40	1:1	4000	70Nm	X	P=30bar	113.5	-	CHUB46	CHSTER40
1220KU_A32_40B10	WELDON 8	1:1	4000	70Nm	X	-	-	88.1	-	-
1220KU_A32_40B12	WELDON 12	1:1	4000	70Nm	X	-	-	92.6	-	-
1220KU_A32_40B14	WELDON 16	1:1	4000	70Nm	X	-	-	95.1	-	-

**OKUMA**  
 MOD: LB15/300 - LT15/300 - LR15 - LU15M - LU300M - GENOS L300M - MACTURN 250/350/550 - ES L10M

MODULO MOTORIZZATO ASSIALE VDI40  
 Axial driven tool VDI40  
 Axial angetriebenes Werkzeug VDI40

Subject to change without notice.

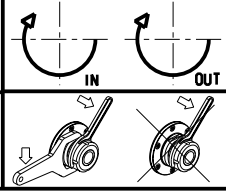

**M.T. srl**  
 Via Casino Albini 480  
 Tel. 0541/956034-957884  
 Fax 0541/956341  
 47842 S. GIOVANNI IN M. (RN)  
 e-mail: mtma@mtmarchetti.com  
 http://www.mtmarchetti.com

PRODUZIONE MODULI ROTANTI



PAGINA OKU150-2-00

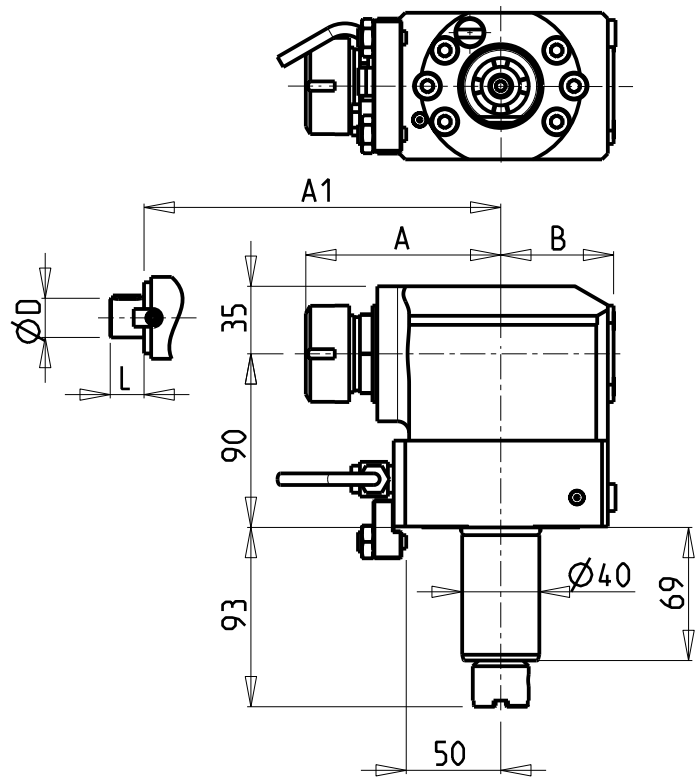

### ATTENZIONE - ATTENTION - ACHTUNG

- Per lo smontaggio degli utensili utilizzare sempre la chiave di contrasto come indicato nel manuale d'uso.
- For disassembly of the tools use always the contrast key as mentioned in the user instructions.
- Fuer das Abmontieren der Werkzeuge immer den Gegenschlüssel benutzen wie in der Bedienungsanleitung erwäehnt.

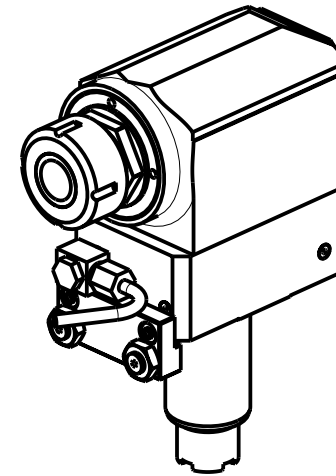

### TORRETTE RADIALI RADIAL TURRETS RADIAL REVOLVER

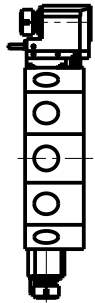

- Chiave inclusa
- Key included
- Schlüssel inbegriffen

Cod. MT	Mandrino Spindle Spindel	I	RPM	Coppia Max Max Torque Max Drehmoment	Lubrificazione int. Coolant through Innenkuhlung	Lubrificazione est. Ext. coolant Aussenkuhlung	A	A1	B	D	L	CHIAVI NON INCLUDE Keys not included Schlüssel nicht einbegriffen	
OKU0020132	ER32	1:1	4000	70Nm	-	X	99.7	-	58.5	-	-	OKU0650004	CHSTER32
OKU0020232	ER32	1:1	4000	70Nm	P=70bar	X	99.7	-	69.5	-	-	OKU0650004	CHSTER32
OKU0020140	ER40	1:1	4000	70Nm	-	X	103.7	-	58.5	-	-	OKU0650004	CHSTER40
OKU0020240	ER40	1:1	4000	70Nm	P=70bar	X	103.7	-	69.5	-	-	OKU0650004	CHSTER40
OKU0022219	Ø22x19	1:1	4000	70Nm	-	X	-	78.5	58.5	22	19	CHUB41	CH_VTCROCE_M10
OKU0022721	Ø27x21	1:1	4000	70Nm	-	X	-	78.5	58.5	27	21	CHUB41	CH_VTCROCE_M12

OKUMA  
MOD: LB15/300 - LT15/300 - LR15 - LU15M - LU300M - MACTURN 250/350/550

MODULO MOTORIZZATO ASSIALE VDI40 H=90mm  
Axial driven tool VDI40 H=90mm  
Axial angetriebenes Werkzeug VDI40 H=90mm

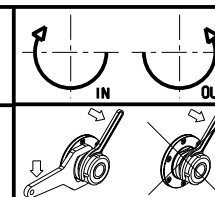

**M.T. srl**  
Via Casino Albini 480  
Tel. 0541/956034-957884  
Fax 0541/956341  
47842 S. GIOVANNI IN M. (RN)  
e-mail: mtma@mtmarchetti.com  
http://www.mtmarchetti.com

PRODUZIONE MODULI ROTANTI



PAGINA OKU150-2-10

Subject to change without notice.

10/2018

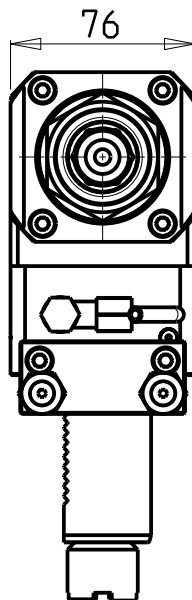
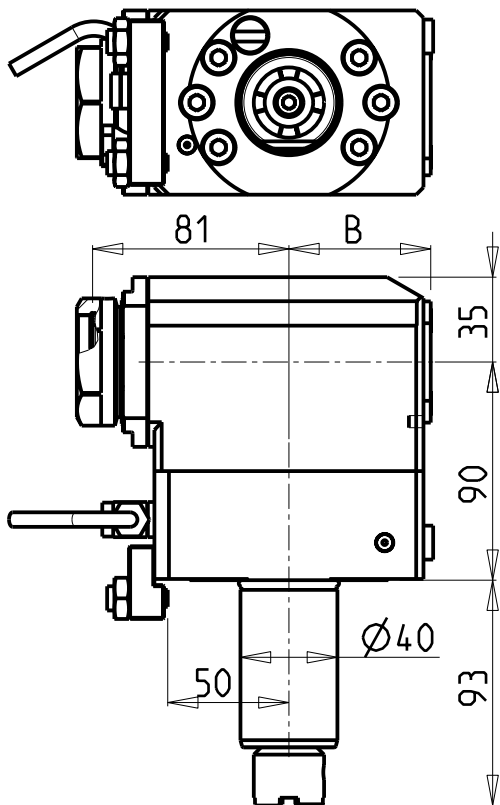

**TORRETTE RADIALI  
RADIAL TURRETS  
RADIAL REVOLVER**

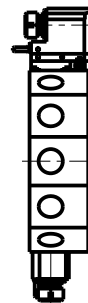

**ATTENZIONE - ATTENTION - ACHTUNG**

- Per lo smontaggio degli utensili utilizzare sempre la chiave di contrasto come indicato nel manuale d'uso.
- For disassembly of the tools use always the contrast key as mentioned in the user instructions.
- Fuer das Abmontieren der Werkzeuge immer den Gegenschlüssel benutzen wie in der Bedienungsanleitung erwäehnt.

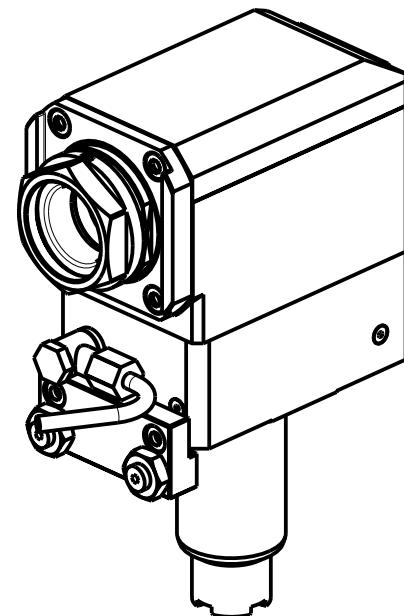

- Chiave inclusa
- Key included
- Schluessel inbegriffen

PER PORTAUTENSILI MODULARI MTSK-40 VEDI PAG. TBL300-1-40  
FOR MTSK-40 QUICK CHANGE TOOLHOLDERS CLAMPINGS SEE PAGE TBL300-1-40  
FUER MTSK-40 MODULARE WERKZEUGAUFNAHMEN SIEHE SEITE TBL300-1-40

Cod. MT	Mandrino Spindle Spindel	I	RPM	Coppia Max Max Torque Max Drehmoment	Lubrificazione int. Coolant through Innenkuehlung	Lubrificazione est. Ext. coolant Aussenkuehlung	B	CHIAVI NON INCLUSE Keys not included Schluessel nicht inbegriffen	
OKU0650140	MTSK-40	1:1	4000	70Nm	-	X	58.5	CHUB46	OKU0650004 *
OKU0650240	MTSK-40	1:1	4000	70Nm	P=70bar	X	69.5	CHUB46	OKU0650004 *

**OKUMA**  
MOD: LB15/300 - LT15/300 - LR15 - LU15M - LU300M - MACTURN 250/350/550

MODULO MOTORIZZATO ASSIALE MTSK VDI40 H=90mm  
Axial MTSK driven tool VDI40 H=90mm  
Axial MTSK angetriebenes Werkzeug VDI40 H=90mm

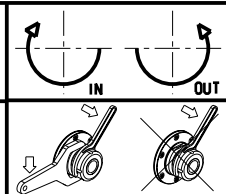

**M.T. srl**  
Via Casino Albini 480  
Tel. 0541/956034-957884  
Fax 0541/956341  
47842 S. GIOVANNI IN M. (RN)  
e-mail: mtma@mtmarchetti.com  
http://www.mtmarchetti.com

PRODUZIONE MODULI ROTANTI



PAGINA OKU150-2-10-K

Subject to change without notice.

10/2018



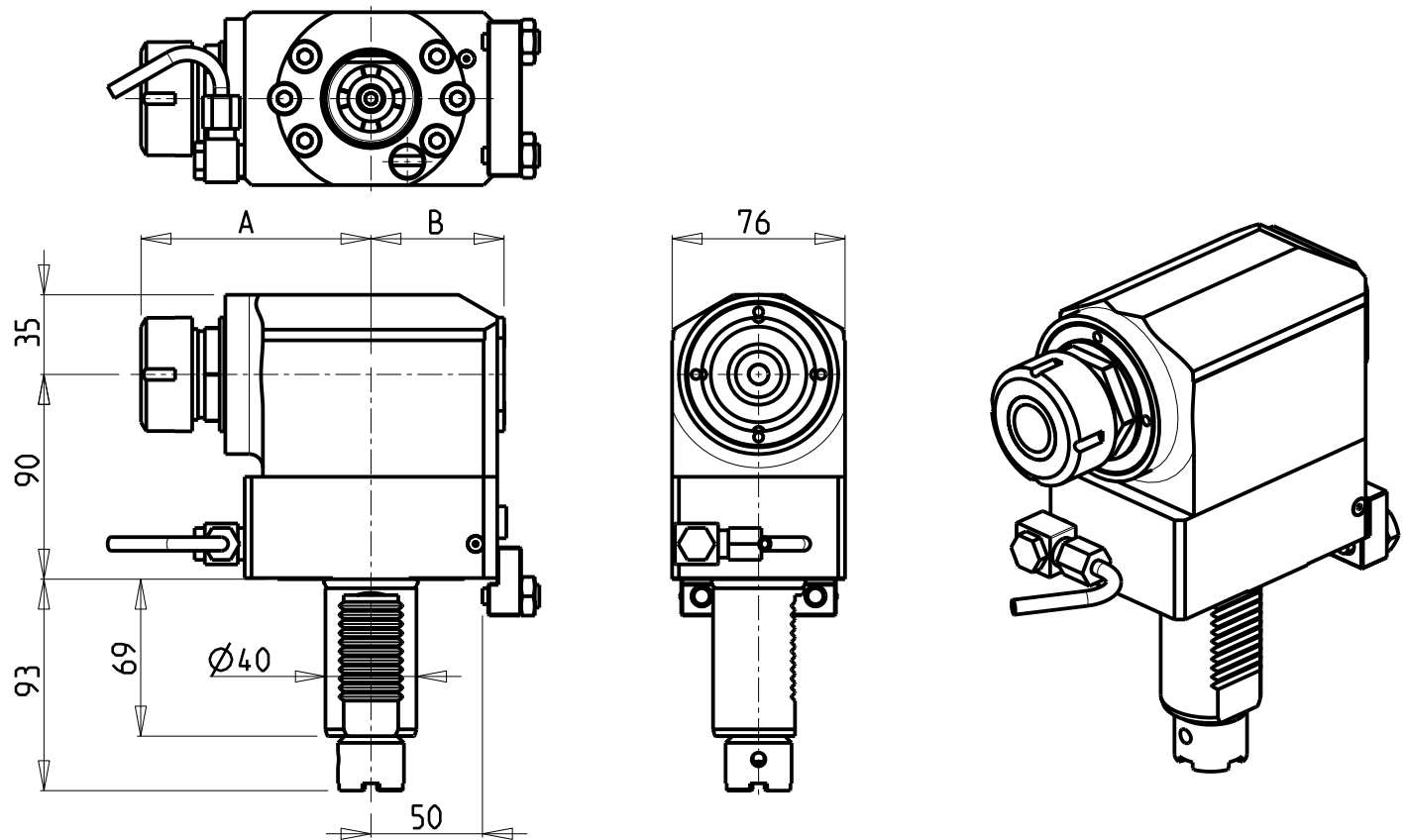

**ATTENZIONE - ATTENTION - ACHTUNG**

- Per lo smontaggio degli utensili utilizzare sempre la chiave di contrasto come indicato nel manuale d'uso.
- For disassembly of the tools use always the contrast key as mentioned in the user instructions.
- Fuer das Abmontieren der Werkzeuge immer den Gegenschluessel benutzen wie in der Bedienungsanleitung erwaehtnt.

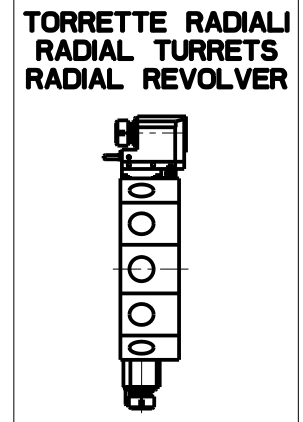

Cod. MT	Mandrino Spindle Spindel	I	RPM	Coppia Max Max Torque Max Drehmoment	Lubrificazione int. Coolant through Innenkuehlung	Lubrificazione est. Ext. coolant Aussenkuehlung	A	B	CHIAVI NON INCLUSE Keys not included Schluessel nicht einbegriffen	
OKU0120132	ER32	1:1	4000	70Nm	-	X	99.7	58.5	OKU0650004	CHSTER32
OKU0120232	ER32	1:1	4000	70Nm	P=70bar	X	99.7	69.5	OKU0650004	CHSTER32
OKU0120140	ER40	1:1	4000	70Nm	-	X	103.7	58.5	OKU0650004	CHSTER40
OKU0120240	ER40	1:1	4000	70Nm	P=70bar	X	103.7	69.5	OKU0650004	CHSTER40

- Chiave inclusa
- Key included
- Schluessel inbegriffen

**OKUMA**  
 MOD: LB15/300 - LT15/300 - LR15 - LU15M - LU300M - MACTURN 250/350/550

MODULO MOTORIZZATO ASSIALE PER CONTROMANDRINO VDI40 H=90mm  
 Axial driven tool for subspindle VDI40 H=90mm  
 Axial angetriebenes Werkzeug fuer Gegenspindel VDI40 H=90mm

Subject to change without notice.

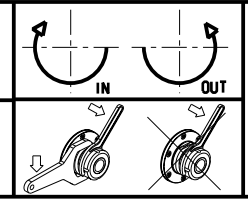

**M.T. srl**  
 Via Casino Albini 480  
 Tel. 0541/956034-957884  
 Fax 0541/956341  
 47842 S. GIOVANNI IN M. (RN)  
 e-mail: mtma@mtmarchetti.com  
 http://www.mtmarchetti.com

PRODUZIONE MODULI ROTANTI

PAGINA OKU155-2-10

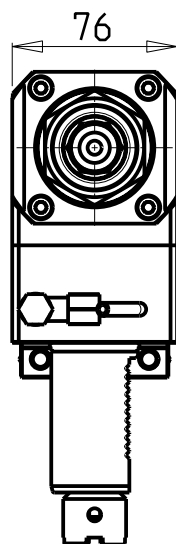
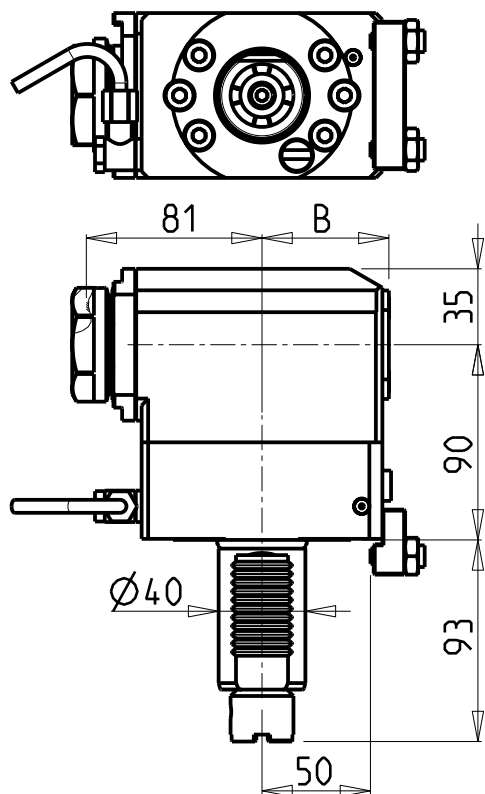

**TORRETTE RADIALI  
RADIAL TURRETS  
RADIAL REVOLVER**

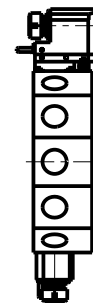

**ATTENZIONE - ATTENTION - ACHTUNG**

- Per lo smontaggio degli utensili utilizzare sempre la chiave di contrasto come indicato nel manuale d'uso.
- For disassembly of the tools use always the contrast key as mentioned in the user instructions.
- Fuer das Abmontieren der Werkzeuge immer den Gegenschlüssel benutzen wie in der Bedienungsanleitung erwaeht.

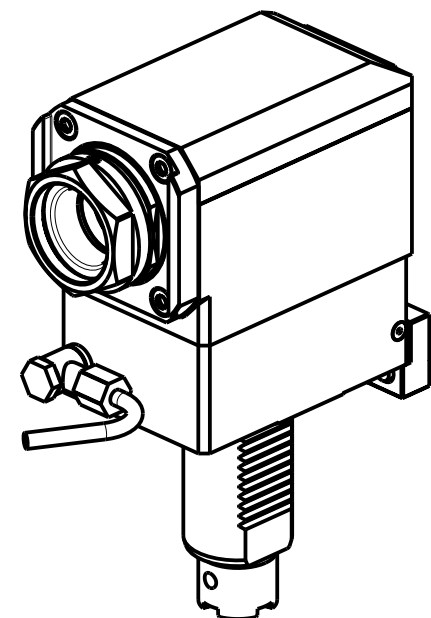

- Chiave inclusa
- Key included
- Schluessel inbegriffen

PER PORTAUTENSILI MODULARI MTSK-40 VEDI PAG. TBL300-1-40  
FOR MTSK-40 QUICK CHANGE TOOLHOLDERS CLAMPINGS SEE PAGE TBL300-1-40  
FUER MTSK-40 MODULARE WERKZEUGAUFNAHMEN SIEHE SEITE TBL300-1-40

Cod. MT	Mandrino Spindel Spindel	I	RPM	Coppia Max Max Torque Max Drehmoment	Lubrificazione int. Coolant through Innenkuehlung	Lubrificazione est. Ext. coolant Aussenkuehlung	B	CHIAVI NON INCLUSE Keys not included Schluessel nicht einbegriffen	
OKU0660140	MTSK-40	1:1	4000	70Nm	-	X	58.5	CHUB46	OKU0650004 ▪
OKU0660240	MTSK-40	1:1	4000	70Nm	P=70bar	X	69.5	CHUB46	OKU0650004 ▪

**OKUMA**  
MOD: LB15/300 - LT15/300 - LR15 - LU15M - LU300M - MACTURN 250/350/550

MODULO MOTORIZZATO ASSIALE MTSK PER CONTROMANDRINO VDI40 H=90mm  
Axial MTSK driven tool for subspindle VDI40 H=90mm  
Axial MTSK angetriebenes Werkzeug fuer Gegenspindel VDI40 H=90mm

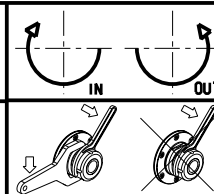

**M.T. srl**  
Via Casino Albini 480  
Tel. 0541/956034-957884  
Fax 0541/956341  
47842 S. GIOVANNI IN M. (RN)  
e-mail: mtma@mtmarchetti.com  
http://www.mtmarchetti.com

PRODUZIONE MODULI ROTANTI



PAGINA OKU155-2-10-K

**ATTENZIONE - ATTENTION - ACHTUNG**

- Per lo smontaggio degli utensili utilizzare sempre la chiave di contrasto come indicato nel manuale d'uso.
- For disassembly of the tools use always the contrast key as mentioned in the user instructions.
- Fuer das Abmontieren der Werkzeuge immer den Gegenschlüssel benutzen wie in der Bedienungsanleitung erwaeht.

**TORRETTE ASSIALI  
AXIAL TURRETS  
AXIAL REVOLVER**

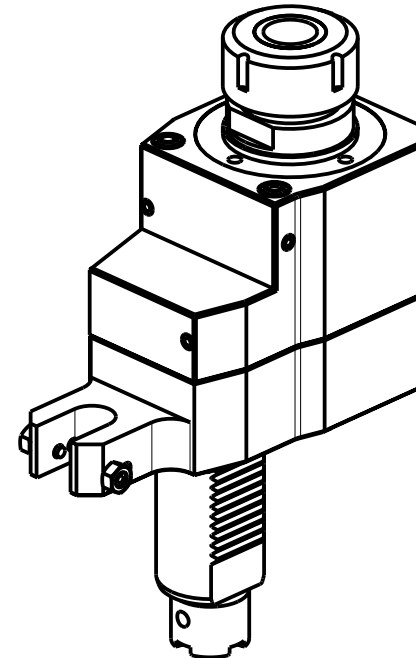
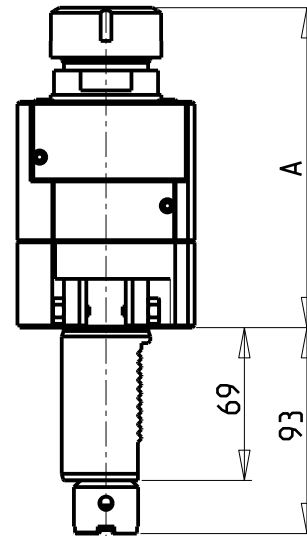
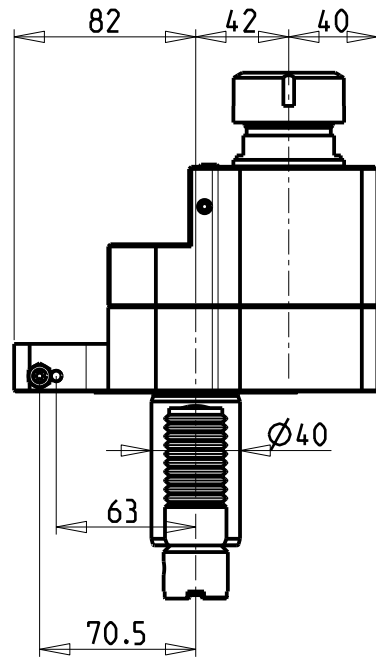
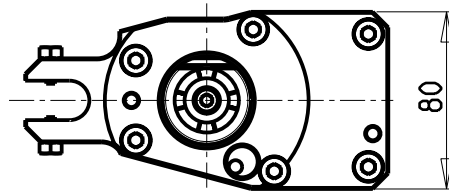
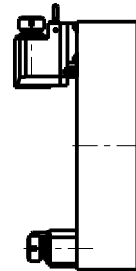

Cod. MT	Mandrino Spindle Spindel	I	RPM	Coppia Max Max Torque Max Drehmoment	Lubrificazione int. Coolant through Innenkuehlung	Lubrificazione est. Ext. coolant Ausenkuehlung	A	CHIAVI NON INCLUSE Keys not included Schlüssel nicht einbegriffen	
								CHUB41	CHSTER32
1250KU_A32_40B00	ER32	1:1	4000	70Nm		X	144.46	CHUB41	CHSTER32
1250KU_A32_40B30	ER32	1:1	4000	70Nm	P=30bar		164.96	CHUB38	CHSTER32

**OKUMA**

MOD: LB15/300 - LT15/300 - LR15 - LU15M - LU300M - GENOS L300M - ES L10M

MODULO MOTORIZZATO ASSIALE DISASSATO VDI40

Axial re-directed driven tool VDI40

Axial angetriebenes Werkzeug achsversetzt VDI40

Subject to change without notice.

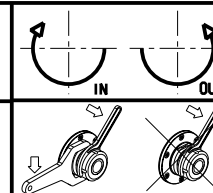

**M.T. srl**

Via Casino Albini 480  
Tel. 0541/956034-957884  
Fax 0541/956341  
47842 S. GIOVANNI IN M. (RN)  
e-mail: mtma@mtmarchetti.com  
http://www.mtmarchetti.com

PRODUZIONE MODULI ROTANTI



PAGINA OKU160-2-00

**ATTENZIONE - ATTENTION - ACHTUNG**

- Per lo smontaggio degli utensili utilizzare sempre la chiave di contrasto come indicato nel manuale d'uso.
- For disassembly of the tools use always the contrast key as mentioned in the user instructions.
- Fuer das Abmontieren der Werkzeuge immer den Gegenschlüssel benutzen wie in der Bedienungsanleitung erwaeht.

**TORRETTE ASSIALI  
AXIAL TURRETS  
AXIAL REVOLVER**

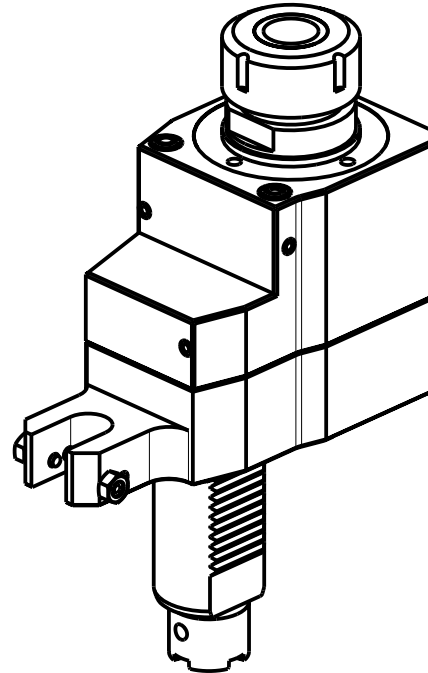
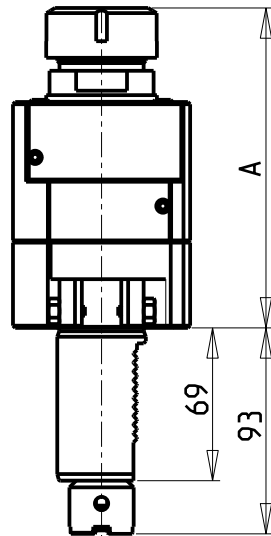
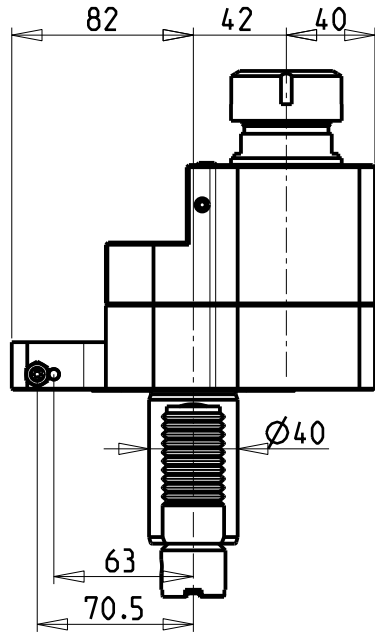
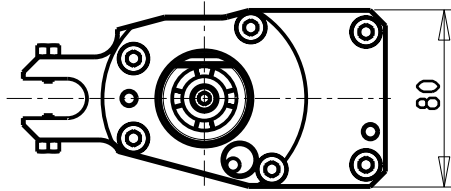
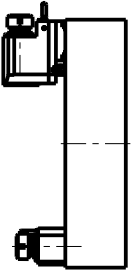

Cod. MT	Mandrino Spindle Spindel	I	RPM	Coppia Max Max Torque Max Drehmoment	Lubrificazione int. Coolant through Innenkuehlung	Lubrificazione est. Ext. coolant Aussenkuehlung	A	CHIAVI NON INCLUSE Keys not included Schlüssel nicht einbegriffen	
1250KU_A32_40B10	ER32	2:1	2000	100Nm		X	144.46	CHUB41	CHSTER32
1250KU_A32_40B20	ER32	2:1	2000	100Nm	P=30bar		164.96	CHUB38	CHSTER32

**OKUMA**

MOD: LB15/300 - LT15/300 - LR15 - LU15M - LU300M - GENOS L300M - ES L10M

MODULO MOTORIZZATO ASSIALE RIDOTTO I=2:1 DISASSATO VDI40

Axial geared-down I=2:1 driven tool re-directed VDI40

Axial angetriebenes Werkzeug untersetzt I=2:1 achsversetzt VDI40

Subject to change without notice.

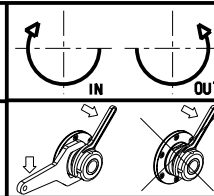

**M.T. srl**

Via Casino Albini 480  
Tel. 0541/956034-957884

Fax 0541/956341

47842 S. GIOVANNI IN M. (RN)

e-mail: mtma@mtmarchetti.com

http://www.mtmarchetti.com

PRODUZIONE MODULI ROTANTI



PAGINA OKU160-2-10

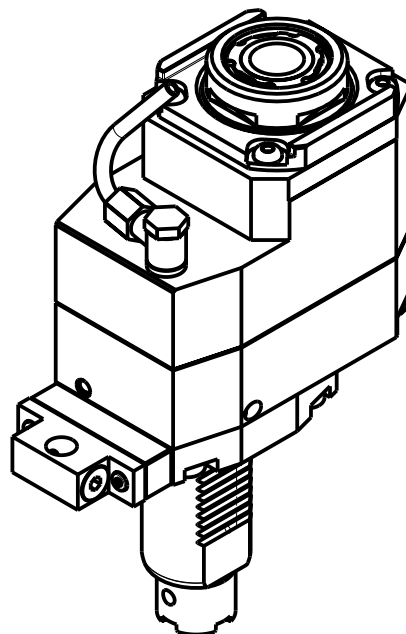
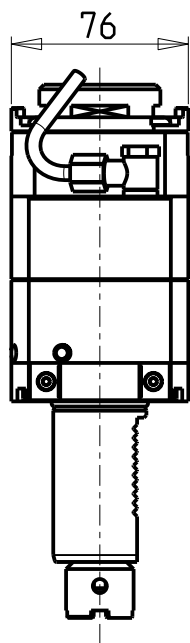
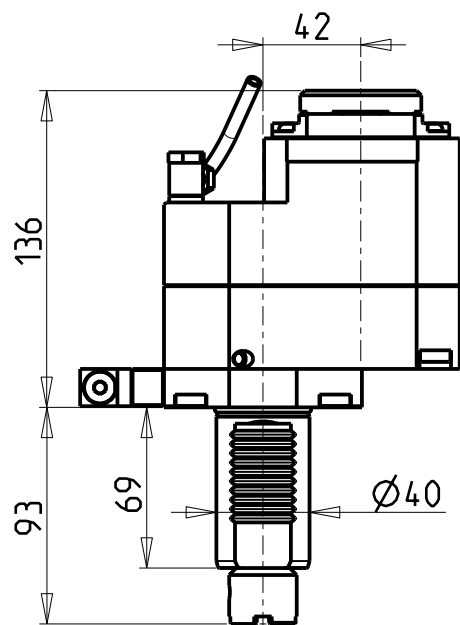
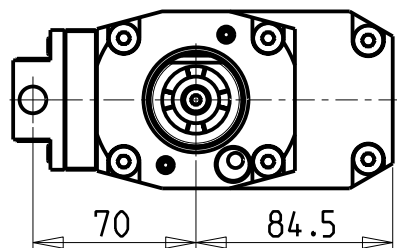

### ATTENZIONE - ATTENTION - ACHTUNG

- Per lo smontaggio degli utensili utilizzare sempre la chiave di contrasto come indicato nel manuale d'uso.
- For disassembly of the tools use always the contrast key as mentioned in the user instructions.
- Fuer das Abmontieren der Werkzeuge immer den Gegenschlüssel benutzen wie in der Bedienungsanleitung erwaeht.

### TORRETTE ASSIALI AXIAL TURRETS AXIAL REVOLVER

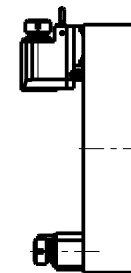

- Chiave inclusa
- Key included
- Schluessel inbegriffen

Cod. MT	Mandrino Spindle Spindel	I	RPM	Coppia Max Max Torque Max Drehmoment	Lubrificazione int. Coolant through Innenkuehlung	Lubrificazione est. Ext. coolant Aussenkuehlung	CHIAVI NON INCLUSE Keys not included Schluessel nicht einbegriffen		
OKU1197132	ERA32	1:2	8000	45Nm	-	X	CHUB30	CHTAER32ZC *	OKU0650004 *
OKU1197232	ERA32	1:2	8000	45Nm	P=70bar	X	CHUB30	CHTAER32ZC *	OKU0650004 *

OKUMA

MOD: LB15/300 - LT15/300 - LR15 - LU15M - LU300M - GENOS L300M - ES L10M

MODULO MOTORIZZATO ASSIALE MOLTIPLICATO I=1:2 DISASSATO 42mm VD140

Axial geared-up I=1:2 driven tool re-directed by 42mm VD140

Axial angetriebenes Werkzeug uebersetzt I=1:2 achsversetzt um 42mm VD140

Subject to change without notice.

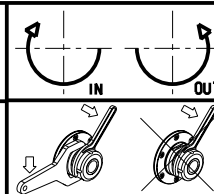

**M.T. srl**

Via Casino Albini 480  
Tel. 0541/956034-957884  
Fax 0541/956341  
47842 S. GIOVANNI IN M. (RN)  
e-mail: mtma@mtmarchetti.com  
http://www.mtmarchetti.com

PRODUZIONE MODULI ROTANTI



PAGINA OKU160-2-20

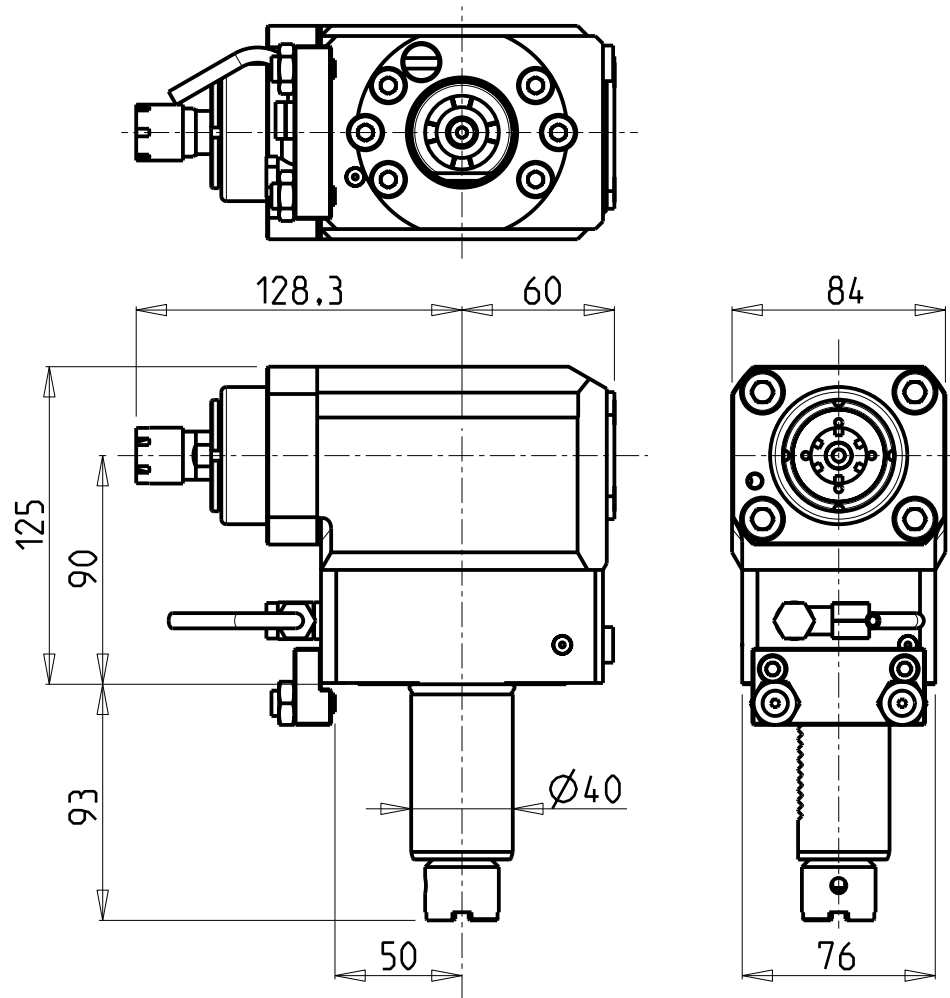

**ATTENZIONE - ATTENTION - ACHTUNG**

- Per lo smontaggio degli utensili utilizzare sempre la chiave di contrasto come indicato nel manuale d'uso.
- For disassembly of the tools use always the contrast key as mentioned in the user instructions.
- Fuer das Abmontieren der Werkzeuge immer den Gegenschlüssel benutzen wie in der Bedienungsanleitung erwaeht.

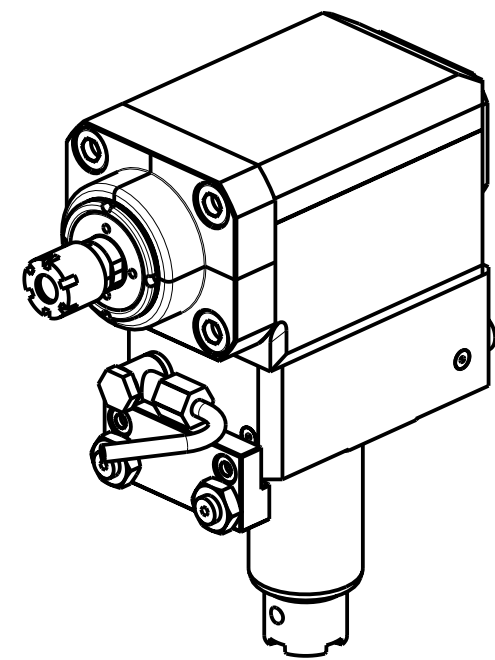

**TORRETTE RADIALI  
RADIAL TURRETS  
RADIAL REVOLVER**

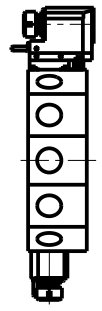

Cod. MT	Mandrino Spindle Spindel	I	RPM	Coppia Max Max Torque Max Drehmoment	Lubrificazione est. Ext. coolant Aussenkuhlung	CHIAVI INCLUSE Keys included Schlüssel einbegriffen	
OKU1270016	ER16	1:3	12000	10Nm	X	CHUB17	CHMNER16

**OKUMA**

MOD: LB15/300 - LT15/300 - LR15 - LU15M - LU300M - MACTURN 250/350/550

MODULO MOTORIZZATO ASSIALE MOLTIPLICATO I=1:3 VDI40 H=90mm

Axial geared-up I=1:3 driven tool VDI40 H=90mm

Axial angetriebenes Werkzeug uebersetzt I=1:3 VDI40 H=90mm

Subject to change without notice.

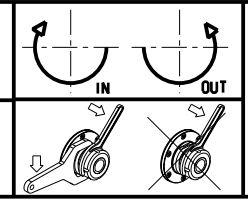

**M.T. srl**  
Via Casino Albini 480  
Tel. 0541/956034-957884  
Fax 0541/956341  
47842 S. GIOVANNI IN M. (RN)  
e-mail: mtma@mtmarchetti.com  
http://www.mtmarchetti.com

PRODUZIONE MODULI ROTANTI



PAGINA OKU208-2-10

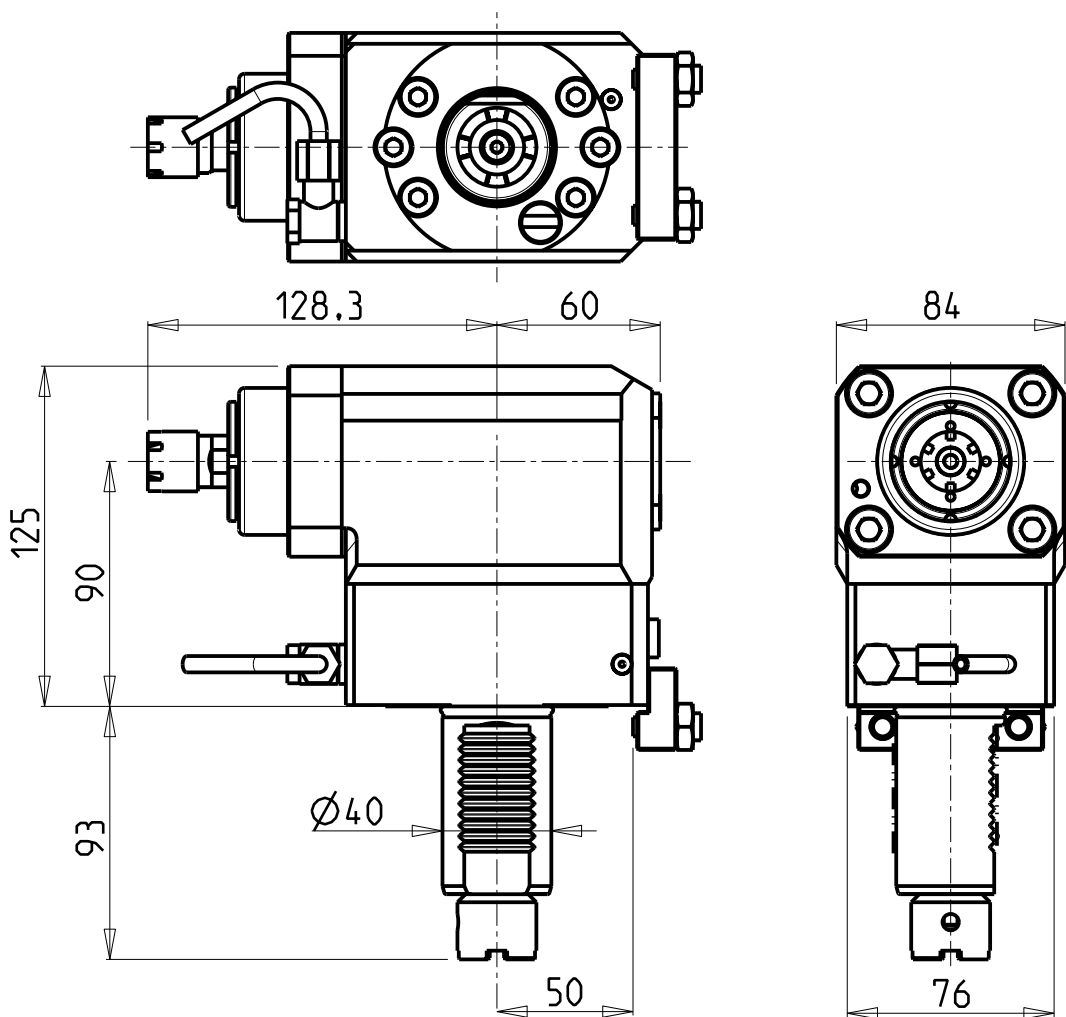

**ATTENZIONE - ATTENTION - ACHTUNG**

- Per lo smontaggio degli utensili utilizzare sempre la chiave di contrasto come indicato nel manuale d'uso.
- For disassembly of the tools use always the contrast key as mentioned in the user instructions.
- Fuer das Abmontieren der Werkzeuge immer den Gegenschlüssel benutzen wie in der Bedienungsanleitung erwaeht.

**TORRETTE RADIALI  
RADIAL TURRETS  
RADIAL REVOLVER**

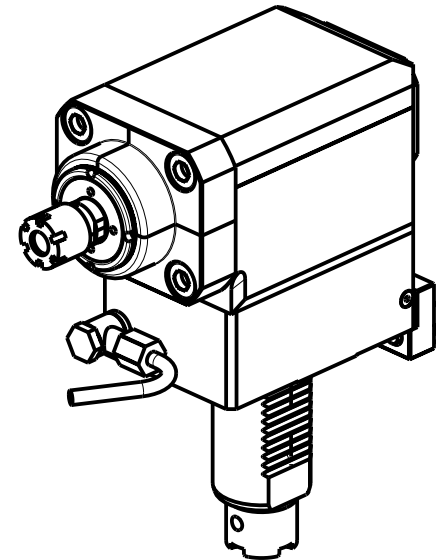
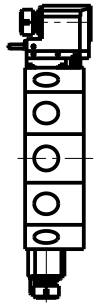

Cod. MT	Mandrino Spindle Spindel	I	RPM	Coppia Max Max Torque Max Drehmoment	Lubrificazione est. Ext. coolant Aussenkuehlung	CHIAVI INCLUSE Keys included Schluessel einbegriffen	
OKU1280016	ER16	1:3	12000	10Nm	X	CHUB17	CHMNER16

**OKUMA**  
 MOD: LB15/300 - LT15/300 - LR15 - LU15M - LU300M - MACTURN 250/350/550

MODULO MOTORIZZATO ASSIALE PER CONTROMANDRINO MOLTIPLICATO I=1:3 VDI40 H=90mm  
 Axial geared-up I=1:3 driven tool for subspindle VDI40 H=90mm  
 Axial angetriebenes Werkzeug fuer Gegenspindel uebersetzt I=1:3 VDI40 H=90mm

Subject to change without notice.

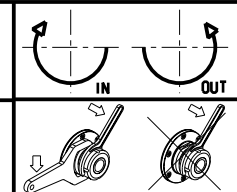

**M.T. srl**  
 Via Casino Albini 480  
 Tel. 0541/956034-957884  
 Fax 0541/956341  
 47842 S. GIOVANNI IN M. (RN)  
 e-mail: mtma@mtmarchetti.com  
 http://www.mtmarchetti.com

PRODUZIONE MODULI ROTANTI



PAGINA OKU209-2-10

**ATTENZIONE - ATTENTION - ACHTUNG**

- Per lo smontaggio degli utensili utilizzare sempre la chiave di contrasto come indicato nel manuale d'uso.
- For disassembly of the tools use always the contrast key as mentioned in the user instructions.
- Fuer das Abmontieren der Werkzeuge immer den Gegenschlüssel benutzen wie in der Bedienungsanleitung erwaeht.

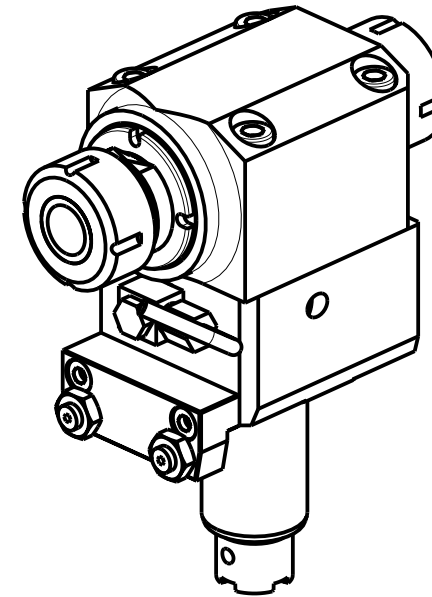
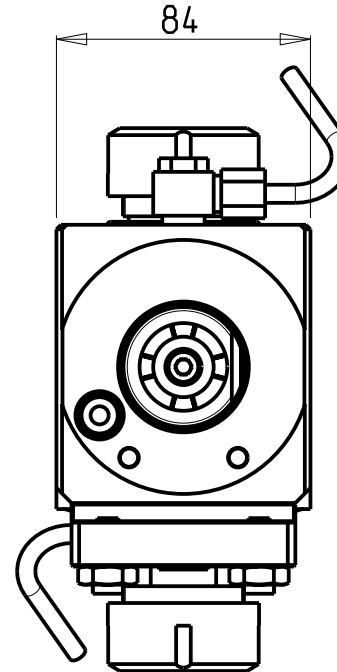
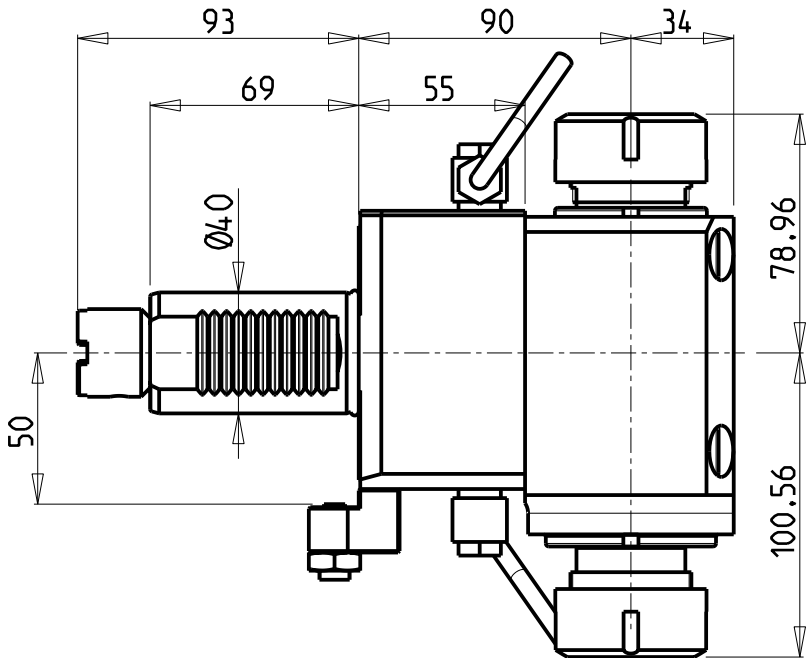

**TORRETTE RADIALI  
RADIAL TURRETS  
RADIAL REVOLVER**

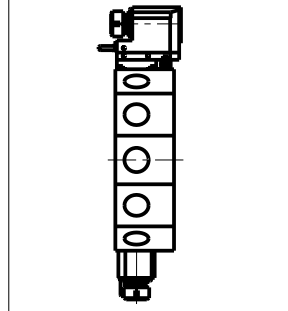

Cod. MT	Mandrino Spindle Spindel	I	RPM	Coppia Max Max Torque Max Drehmoment	Lubrificazione est. Ext. coolant Aussenkuehlung	CHIAVI NON INCLUSE Keys not included Schluessel nicht einbegriffen	
OKU0013232	ER32+ER32	1:1	4000	50Nm	X	CHUB36	CHSTER32

**OKUMA**  
MOD: LB15/300 - LT15/300 - LR15 - LU15M - LU300M - MACTURN 250/350/550

MODULO MOTORIZZATO ASSIALE BISPORGENTE VD140  
Axial opposite face driven tool VD140  
Axial angetriebenes Werkzeug halb vorspringend VDI40

Subject to change without notice.



**M.T. srl**  
Via Casino Albini 480  
Tel. 0541/956034-957884  
Fax 0541/956341  
47842 S. GIOVANNI IN M. (RN)  
e-mail: mtma@mtmarchetti.com  
http://www.mtmarchetti.com

PRODUZIONE MODULI ROTANTI



PAGINA OKU240-2-10



**ATTENZIONE - ATTENTION - ACHTUNG**

- Per lo smontaggio degli utensili utilizzare sempre la chiave di contrasto come indicato nel manuale d'uso.
- For disassembly of the tools use always the contrast key as mentioned in the user instructions.
- Fuer das Abmontieren der Werkzeuge immer den Gegenschlüssel benutzen wie in der Bedienungsanleitung erwaehtnt.

**TORRETTE ASSIALI  
AXIAL TURRETS  
AXIAL REVOLVER**

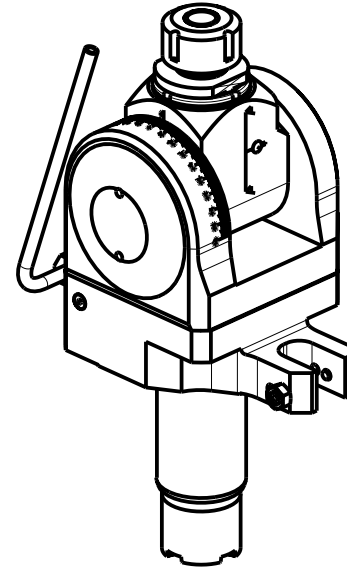
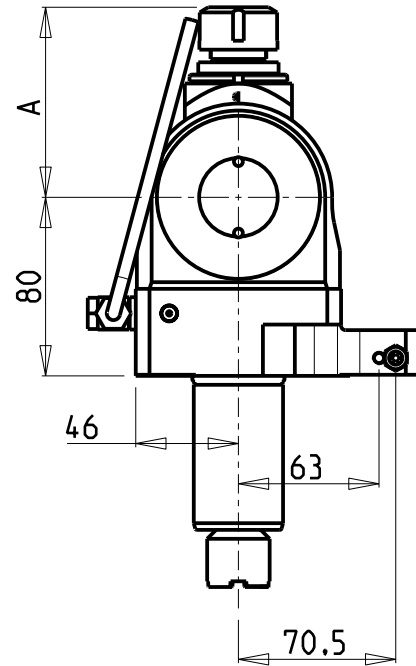
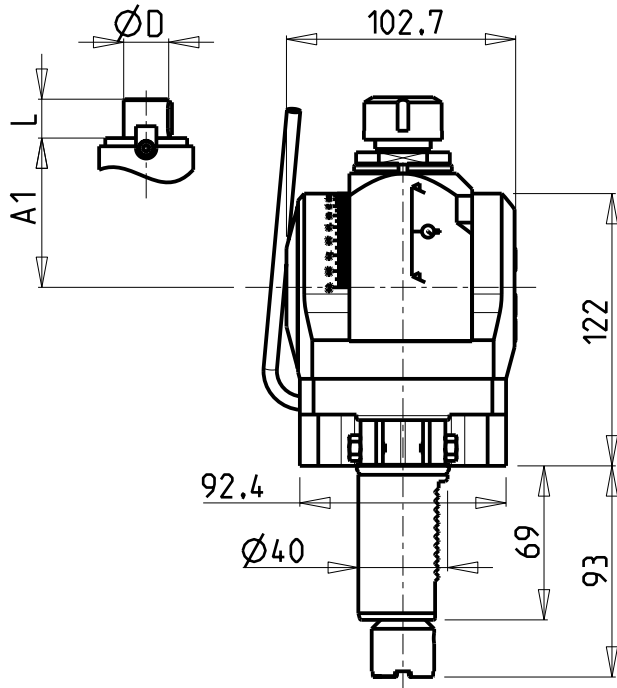
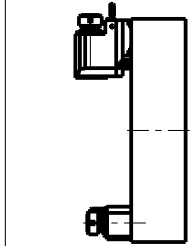

Cod. MT	Mandrino Spindle Spindel	I	RPM	Coppia Max Max Torque Max Drehmoment	Lubrificazione est. Ext. coolant Aussenkuehlung	A	A1	D	L	CHIAVI INCLUSE Keys included Schluessel inbegriffen	
OKU1510120	ER20	1:1	4000	40Nm	X	85.16	-	-	-	CHUB36	CHSTER20
OKU1510125	ER25	1:1	4000	40Nm	X	86.16	-	-	-	CHUB36	CHSTER25
OKU1510516	Ø16x17	1:1	4000	40Nm	X	-	65	16	17	CHUB36	CH_VTCROCE_M08
OKU1510522	Ø22x19	1:1	4000	40Nm	X	-	65	22	19	CHUB36	CH_VTCROCE_M10
OKU1510519	Ø3/4"x3/4"	1:1	4000	40Nm	X	-	65	3/4"	3/4"	CHUB36	CH_VTCROCE_M08

**OKUMA**  
MOD: LB15/300 - LT15/300 - LR15 - LU15M - LU300M - GENOS L300M - ES L10M

MODULO MOTORIZZATO ORIENTABILE ±90° VDI40  
±90° adjustable angle driven tool VDI40  
Angetriebenes Werkzeug schwenkbar ±90° VDI40

Subject to change without notice.

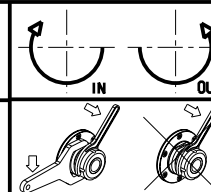

**M.T. srl**

Via Casino Albini 480  
Tel. 0541/956034-957884  
Fax 0541/956341  
47842 S. GIOVANNI IN M. (RN)  
e-mail: mtma@mtmarchetti.com  
http://www.mtmarchetti.com

PRODUZIONE MODULI ROTANTI



PAGINA OKU333-2-00

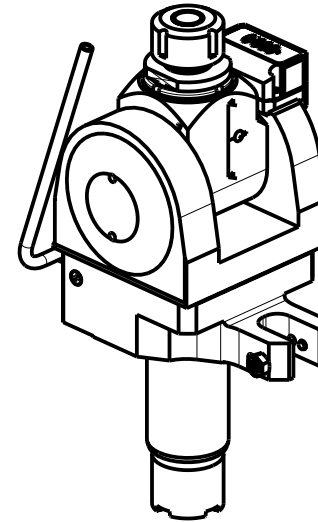
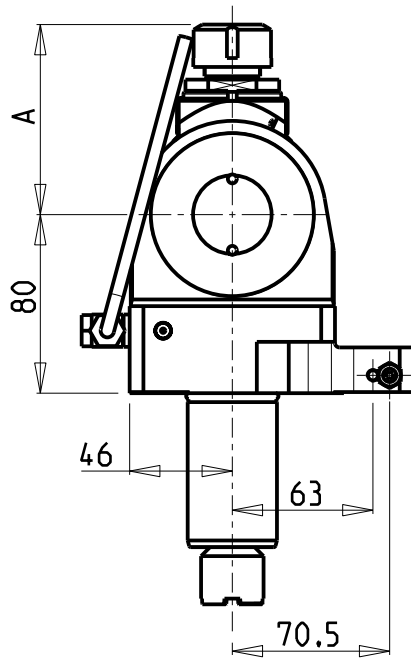
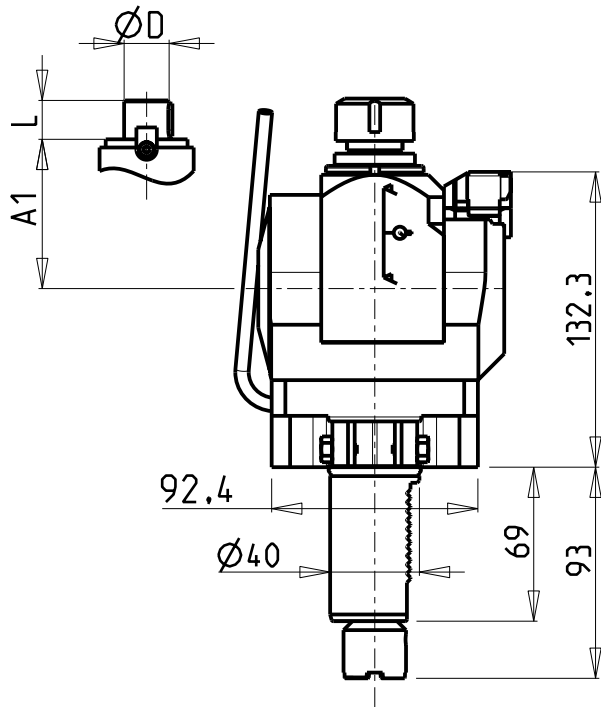

**ATTENZIONE - ATTENTION - ACHTUNG**

- Per lo smontaggio degli utensili utilizzare sempre la chiave di contrasto come indicato nel manuale d'uso.
- For disassembly of the tools use always the contrast key as mentioned in the user instructions.
- Fuer das Abmontieren der Werkzeuge immer den Gegenschlüssel benutzen wie in der Bedienungsanleitung erwaehtnt.

**TORRETTE ASSIALI  
AXIAL TURRETS  
AXIAL REVOLVER**

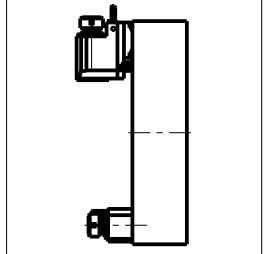

Cod. MT	Mandrino Spindle Spindel	I	RPM	Coppia Max Max Torque Max Drehmoment	Lubrificazione est. Ext. coolant Aussenkuehlung	A	A1	D	L	CHIAVI INCLUSE Keys included Schluessel inbegriffen	
OKU1450120	ER20	1:1	4000	40Nm	X	85.16	-	-	-	CHUB36	CHSTER20
OKU1450125	ER25	1:1	4000	40Nm	X	86.16	-	-	-	CHUB36	CHSTER25
OKU1450516	Ø16x17	1:1	4000	40Nm	X	-	65	16	17	CHUB36	CH_VTCROCE_M08
OKU1450522	Ø22x19	1:1	4000	40Nm	X	-	65	22	19	CHUB36	CH_VTCROCE_M10
OKU1450519	Ø3/4"x3/4"	1:1	4000	40Nm	X	-	65	3/4"	3/4"	CHUB36	CH_VTCROCE_M08

**OKUMA**  
 MOD: LB15/300 - LT15/300 - LR15 - LU15M - LU300M - GENOS L300M - ES L10M

MODULO MOTORIZZATO ORIENTABILE ±90° CON NONIO DIGITALE VD140  
 ±90° adjustable angle driven tool with digital display VD140  
 Angetriebenes Werkzeug schwenkbar ±90° mit digital display VD140

Subject to change without notice.

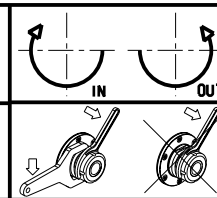

**M.T. srl**  
 Via Casino Albini 480  
 Tel. 0541/956034-957884  
 Fax 0541/956341  
 47842 S. GIOVANNI IN M. (RN)  
 e-mail: mtma@mtmarchetti.com  
 http://www.mtmarchetti.com

PRODUZIONE MODULI ROTANTI



PAGINA OKU333-2-01

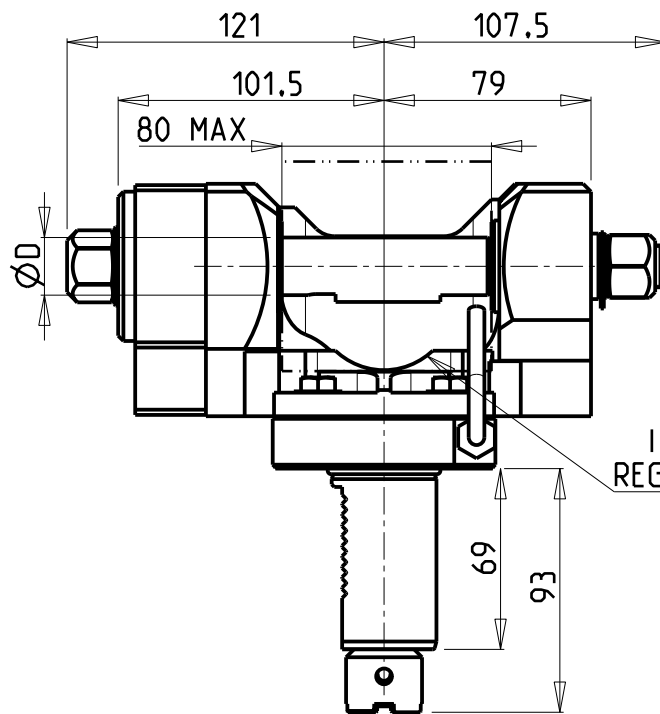
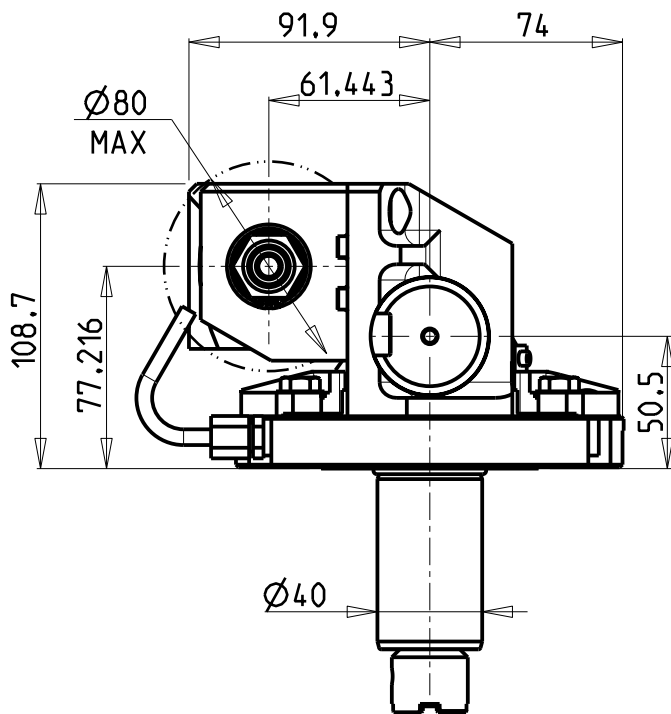

INCLINAZIONE  
REGOLABILE  $\pm 20^\circ$

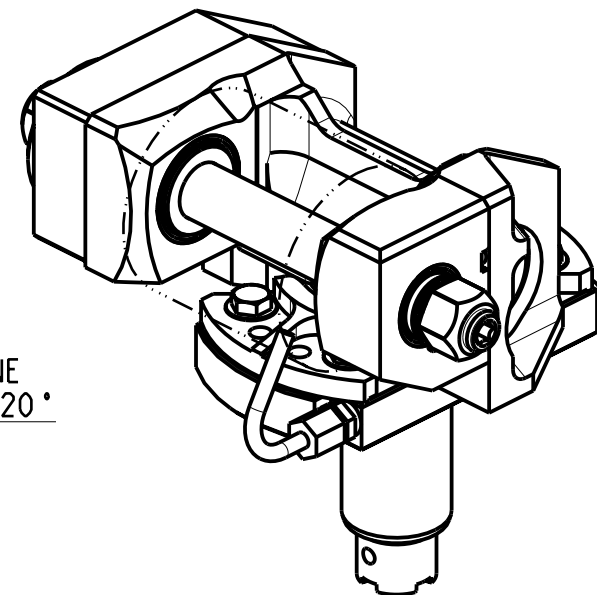

**TORRETTE RADIALI**  
**RADIAL TURRETS**  
**RADIAL REVOLVER**

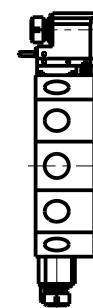

**DOTAZIONI - SUPPLIED WITH - AUSSTATTUNG**

- |           |                             |
|-----------|-----------------------------|
| mm / inch | - N°1 ALBERO + DISTANZIALI  |
|           | - N°1 SHAFT + SPACER        |
|           | - N°1 DORN + ABSTANDSSTUECK |

PER ALBERI E DISTANZIALI VEDI PAG. TBL250-1-00  
FOR SHAFT END SPACER SEE PAGE TBL250-1-00  
FUER DORN UND ABSTANDSSTUECK SEITE TBL250-1-00

Cod. MT	I	RPM MAX	Coppia Max Max Torque Max Drehmoment	Lubr.esterna Ext. coolant Aussenkuehlung	D (mm)	D (Inch)	CHIAVI INCLUSE Keys included Schlüssel inbegriffen		
							CHUB13	CHUB24	CHESL08
1260KU_PCR_40B00	1:1	4000	60Nm	X	16-22-27-32	3/4"-1"-1 1/4"	CHUB13	CHUB24	CHESL08
1260KU_PCR_40B10	2:1	2000	80Nm	X	16-22-27-32	3/4"-1"-1 1/4"	CHUB13	CHUB24	CHESL08

OKUMA

MOD: LB15/300 - LT15/300 - LR15 - LU15M - LU300M

MODULO MOTORIZZATO PORTACREATORE VDI40

Driven gear hobber VDI40

Angetriebenes Zahnradwaeltzraes-Werkzeug VDI40

Subject to change without notice.

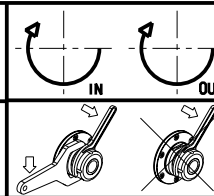

**M.T. srl**

Via Casino Albini 480  
Tel. 0541/956034-957884  
Fax 0541/956341  
47842 S. GIOVANNI IN M. (RN)  
e-mail: mtma@mtmarchetti.com  
http://www.mtmarchetti.com

PRODUZIONE MODULI ROTANTI



PAGINA OKU340-2-00

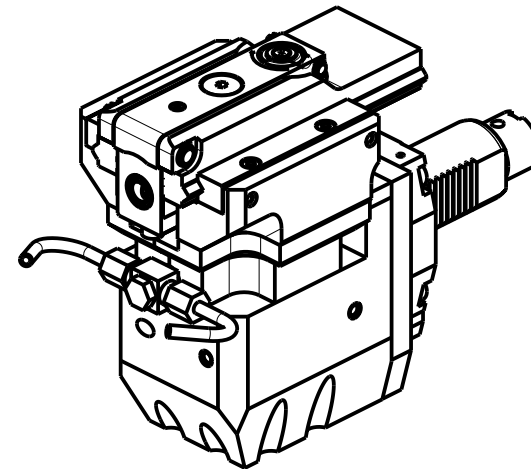
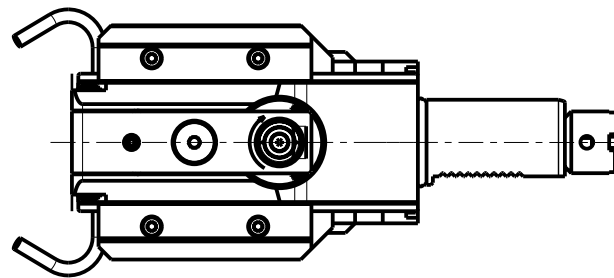
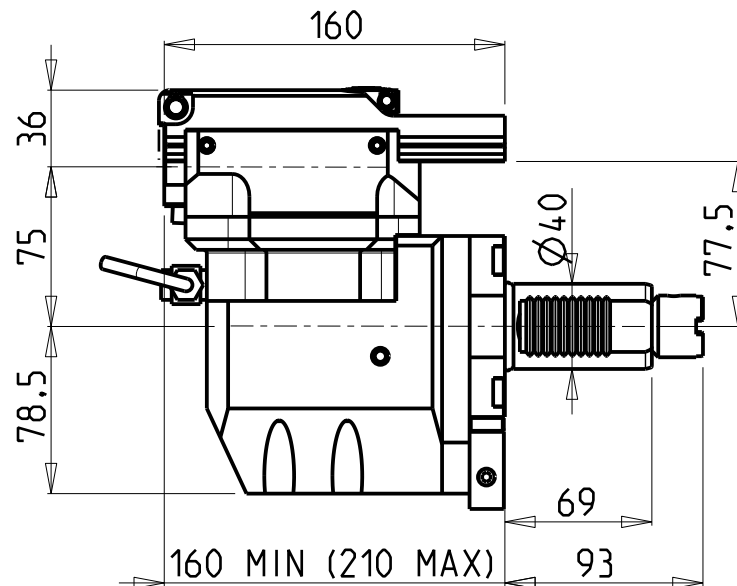
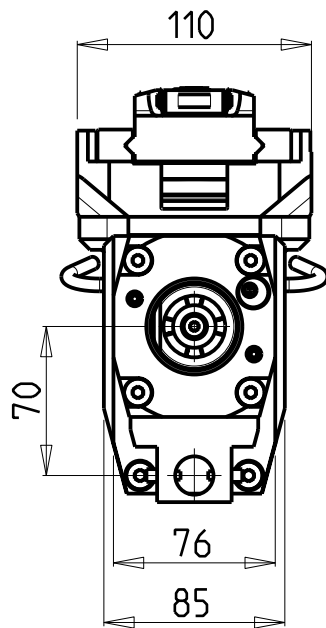

**TORRETTE ASSIALI  
AXIAL TURRETS  
AXIAL REVOLVER**

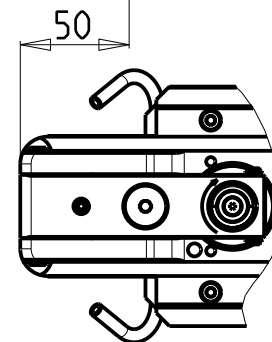
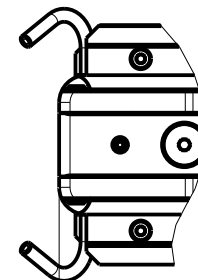
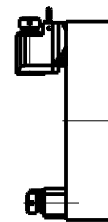

PER UTENSILI STOZZATORI VEDI PAG. TBL400-1-00  
FOR DRIVEN SLOTTING TOOL CUTTING-TOOLS SEE PAGE TBL400-1-00  
FÜR NUTENSTOSS-WERKZEUG SCHNEIDWERKZEUGE SIEHE SEITE TBL400-1-00

Cod. MT	I	RPM MAX	Lubr. esterna Ext. coolant Aussenkuehlung
OKU1360100	4:1	2000	X

**OKUMA**  
MOD: LB15/300 - LT15/300 - LR15 - LU15M - LU300M - GENOS L300M - ES L10M

MODULO MOTORIZZATO STOZZATORE CORSA 50mm VDI40  
Slotting driven tool 50mm stroke VDI40  
Keilnutenstossmaschine 50mm Hub VDI40

Subject to change without notice.

**M.T. srl**  
Via Casino Albini 480  
Tel. 0541/956034-957884  
Fax 0541/956341  
47842 S. GIOVANNI IN M. (RN)  
e-mail: mtma@mtmarchetti.com  
<http://www.mtmarchetti.com>

PRODUZIONE MODULI ROTANTI



PAGINA OKU360-2-30

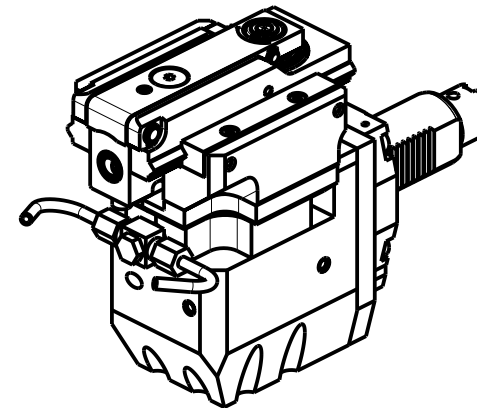
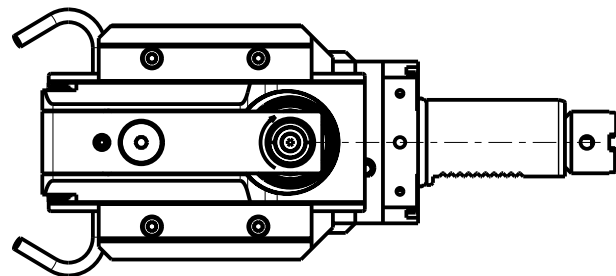
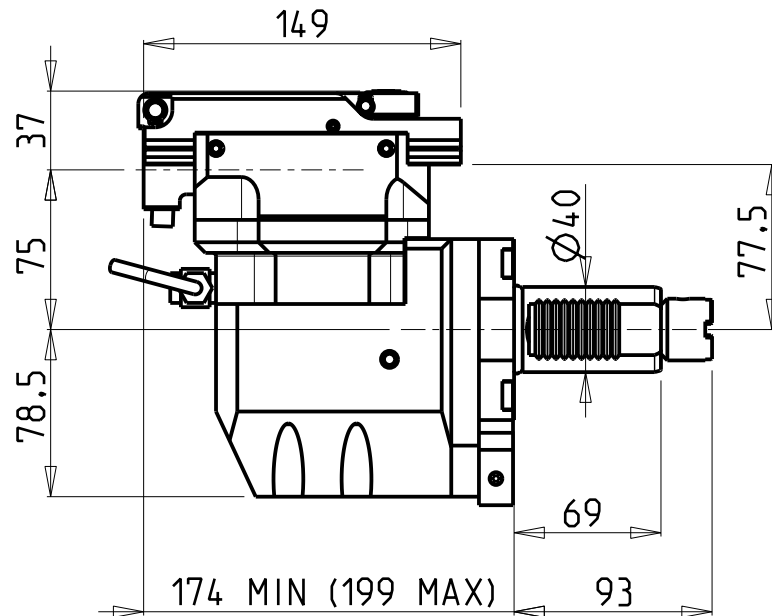
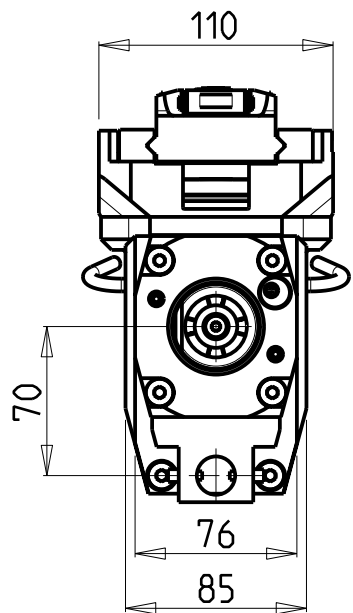

TORRETTE ASSIALI  
AXIAL TURRETS  
AXIAL REVOLVER

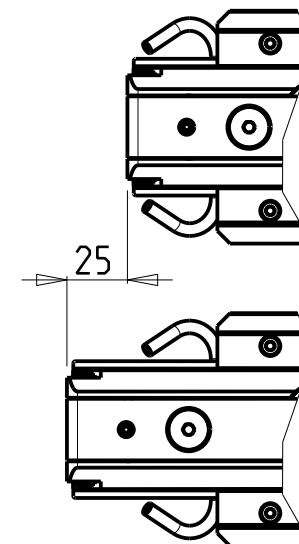
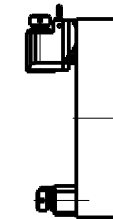

PER UTENSILI STOZZATORI VEDI PAG. TBL400-1-00  
FOR DRIVEN SLOTTING TOOL CUTTING-TOOLS SEE PAGE TBL400-1-00  
FÜR NUTENSTOSS-WERKZEUG SCHNEIDWERKZEUGE SIEHE SEITE TBL400-1-00

Cod. MT	I	RPM MAX	Lubr. esterna Ext. coolant Aussenkuehlung
OKU1360200	4:1	2400	X

OKUMA  
MOD: LB15/300 - LT15/300 - LR15 - LU15M - LU300M - GENOS L300M - ES L10M

MODULO MOTORIZZATO STOZZATORE CORSA 25mm VD140  
Slotting driven tool 25mm stroke VD140  
Keilnutenstossmaschine 25mm Hub VD140

Subject to change without notice.

**M.T. srl**  
Via Casino Albini 480  
Tel. 0541/956034-957884  
Fax 0541/956341  
47842 S. GIOVANNI IN M. (RN)  
e-mail: mtma@mtmarchetti.com  
http://www.mtmarchetti.com

PRODUZIONE MODULI ROTANTI



PAGINA OKU360-2-31

