

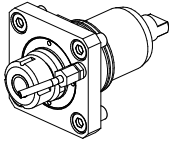

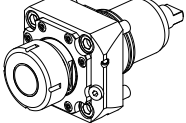
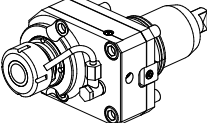
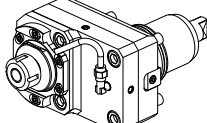
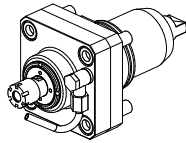
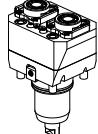
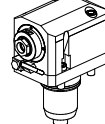
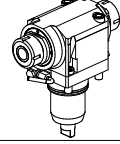
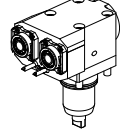

		PAGINA Page Seite
MODULO MOTORIZZATO RADIALE Radial driven tool Radial angetriebenes Werkzeug		NKM010.3.00
MODULO MOTORIZZATO RADIALE MAGGIORATO Radial reinforced driven tool Radial angetriebenes Werkzeug vergrößert		NKM020.3.00
MODULO MOTORIZZATO RADIALE MOLTIPLICATO 1=1:2 DISASSATO IN Z 45mm Radial geared-up 1=1:2 driven tool re-directed in Z by 45mm Radial angetriebenes Werkzeug uebersetzt 1=1:2 achsversetzt in Z um 45mm		NKM030.3.30
MODULO MOTORIZZATO RADIALE DISASSATO IN Z 60mm Radial driven tool re-directed in Z by 60mm Radial angetriebenes Werkzeug achsversetzt in Z um 60mm		NKM033.3.10
MODULO MOTORIZZATO RADIALE MOLTIPLICATO 1=1:3 Radial geared-up 1=1:3 driven tool Radial angetriebenes Werkzeug uebersetzt 1=1:3		NKM055.3.00
MODULO MOTORIZZATO RADIALE 2 USCITE IN Y Radial single side twin head driven tool in Y Radial angetriebenes Werkzeug 2 Ausgaenge in Y		NKM080.3.00
MODULO MOTORIZZATO ASSIALE H=65mm Axial driven tool H=65mm Axial angetriebenes Werkzeug H=65mm		NKM150.3.10
MODULO MOTORIZZATO ASSIALE BISPORGENTE H=65 mm Axial opposite face twin driven tool H=65mm Axial angetriebenes Werkzeug halb vorspringend H=65mm		NKM240.3.10
MODULO MOTORIZZATO ASSIALE 2 USCITE IN Y Axial single side twin head driven tool in Y Axial angetriebenes Werkzeug 2 Ausgaenge in Y		NKM260.3.10
MODULO MOTORIZZATO ORIENTABILE ±90° ±90° adjustable angle driven tool Angetriebenes Werkzeug schwenkbar ±90°		NKM333.3.00
MODULO MOTORIZZATO ORIENTABILE ±90° CON NONIO DIGITALE ±90° adjustable angle driven tool with digital display Angetriebenes Werkzeug schwenkbar ±90° mit digital display		NKM333.3.01
MODULO MOTORIZZATO ORIENTABILE ±90° ±90° adjustable angle driven tool Angetriebenes Werkzeug schwenkbar ±90°		NKM335.3.00

		PAGINA Page Seite
<p>MODULO MOTORIZZATO ORIENTABILE $\pm 90^\circ$ CON NONIO DIGITALE $\pm 90^\circ$ adjustable angle driven tool with digital display Angetriebenes Werkzeug schwenkbar $\pm 90^\circ$ mit digital display</p>		NKM335.3.01
<p>MODULO MOTORIZZATO ORIENTABILE $\pm 90^\circ$ MOLTIPLICATO 1-1.2 $\pm 90^\circ$ adjustable angle driven tool geared-up 1=1.2 $\pm 90^\circ$ adjustable angle driven tool geared-up 1=1.2</p>		NKM336.3.00
<p>MOD. MOTORIZZ. ORIENTABILE $\pm 90^\circ$ MOLTIPL. 1-1.2 CON NONIO DIGITALE $\pm 90^\circ$ adjustable angle driven tool geared-up 1=1.2 with digital display Angetriebenes Werkzeug schwenkbar $\pm 90^\circ$ uebersetzt 1=1.2 mit digital display</p>		NKM336.3.01
<p>MODULO MOTORIZZATO PORTACREATORE Driven gear hobber Angetriebenes Zahnradwaelzfraes-Werkzeug</p>		NKM340.3.00
<p>MODULO MOTORIZZATO ASSIALE MTSK PER POWER SKIVING H=90mm Axial MTSK driven tool for Power Skiving H=90mm Axial MTSK angetriebenes Werkzeug fuer Power Skiving H=90mm</p>		NKM350.3.00.K
<p>MODULO MOTORIZZATO STOZZATORE CORSA 50mm Slotting driven tool 50mm stroke Keilnutenstossmaschine 50mm Hub</p>		NKM360.3.00
<p>MODULO MOTORIZZATO STOZZATORE CORSA 25mm Slotting driven tool 25mm stroke Keilnutenstossmaschine 25mm Hub</p>		NKM360.3.01
<p>MODULO MOTORIZZATO PER LUNETTA RETRATTILE (TAGLIA 1) Driven toolholder for sliding steady rest (Size 1) Luenettenwerkzeug zurueck versetzte Version (Grossesse 1)</p>		NKM363.3.00
<p>PORTAUTENSILE RADIALE SINGOLO QD=25mm Radial single static tool QD=25mm Radial Single-Werkzeughalter QD=25mm</p>		NKM423.3.00
<p>PORTAUTENSILE RADIALE DOPPIO QD=25mm Radial double static tool QD=25mm Radial Doppel-Werkzeughalter QD=25mm</p>		NKM453.3.00
<p>PORTAUTENSILE RADIALE MULTIPLO QD=20mm / QD=3/4" Radial multiple static tool QD=20mm / QD=3/4" Radial Mehrfach-Halter QD=20mm / QD=3/4"</p>		NKM470.3.00
<p>PORTAUTENSILE RADIALE PER LAMA Radial blade holder Radial Abstechhalter</p>		NKM510.3.00

		PAGINA Page Seite
<p>PORTAUTENSILE ASSIALE SINGOLO QD=25mm Axial single static tool QD=25mm Axial Single-Werkzeughalter QD=25mm</p>		NKM552.3.00
<p>PORTAUTENSILE ASSIALE PER BARENO Ø40mm H=90mm Axial single boring bar holder Ø40mm H=90mm Axial Bohrhalter Ø40mm H=90mm</p>		NKM610.3.20
<p>PORTAUTENSILE ASSIALE PER BARENO Ø40mm / Ø32mm H=90mm Axial single boring bar holder Ø40mm / Ø32mm H=90mm Axial Bohrhalter Ø40mm / Ø32mm H=90mm</p>		NKM630.3.10
<p>PORTAUTENSILE ASSIALE PER BARENO 2 POSIZIONI Ø25mm Axial double boring bar holder Ø25mm Axial Bohrhalter 2 Positionen Ø25mm</p>		NKM864.3.00
<p>CONTROPUNTA PER CONTROMANDRINO Tailstock for subspindle Gegenspitz fuer Gegenspindel</p>		NKM950.3.00 

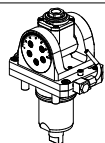
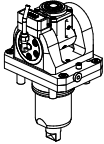
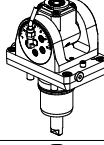
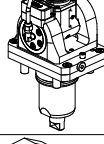
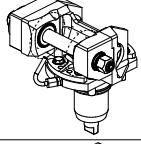
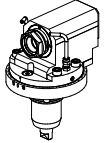
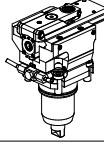
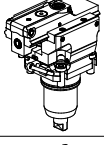
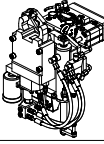
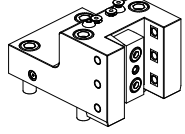
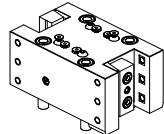
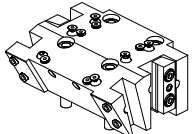
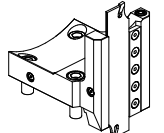
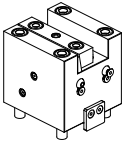
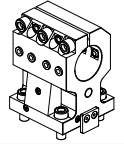
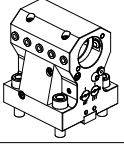
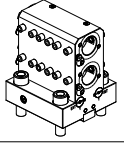
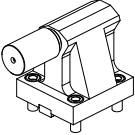

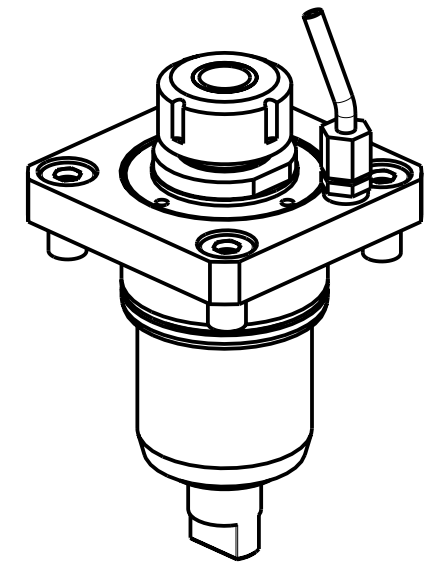
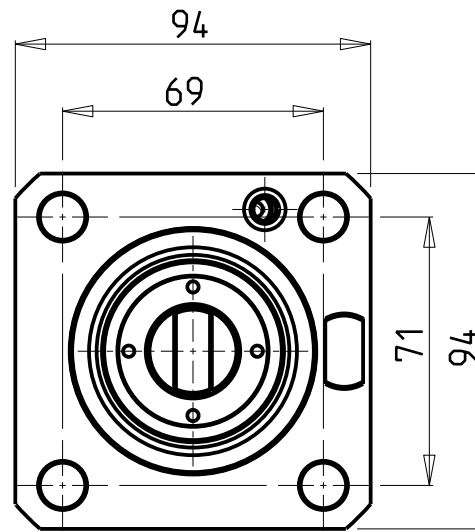
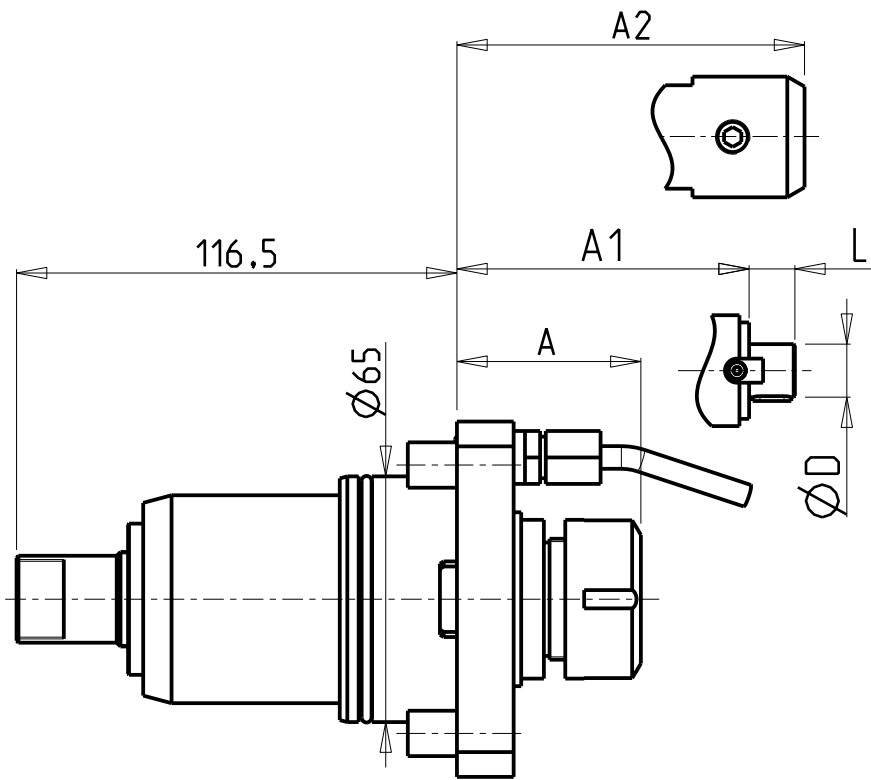
- Chiave inclusa
- Key included
- Schluessel inbegriffen

Cod. MT	Mandrino Spindle Spindel	I	RPM	Coppia Max Max Torque Max Drehmoment	Lubrificazione int. Coolant through Innenkuehlung	Lubrificazione est. Ext. coolant Aussenkuehlung	A	A1	A2	D	L	CHIAVI NON INCLUSE Keys not included Schluessel nicht einbegriffen	
NKM0270125	ER25	1:1	6000	70Nm		X	48.66	-	-	-	-	CHUB42	CHSTER25
NKM0270132	ER32	1:1	6000	70Nm		X	52.16	-	-	-	-	CHUB42	CHSTER32
NKM0270225	ER A 25	1:1	6000	70Nm	P=30bar	X	60.03	-	-	-	-	CHUB46	CHUB27
NKM0270232	ER A 32	1:1	6000	70Nm	P=30bar	X	67.53	-	-	-	-	CHUB46	CHUB32
NKM0270422	Ø22x19	1:1	6000	70Nm		X	-	35	-	22	19	CHUB42	CH_VTCROCE_M10 *
NKM0270325	WELDON 25	1:1	6000	70Nm	P=30bar	X	-		65	-	-		

NAKAMURA - TOME

WT300 - SC300 - SC30011 - TMC200/300M - SUPER NTX - SUPER NTXL - TW20M/MY/MM/MYY/MYY 12 ST.
TW30M/MY/MM/MYY/MYY 16 ST.

MODULO MOTORIZZATO RADIALE

Radial driven tool
Radial angetriebenes Werkzeug

Subject to change without notice.

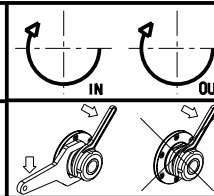

M.T. srl

Via Casino Albini 480
Tel. 0541/956034-957884
Fax 0541/956341
47842 S. GIOVANNI IN M. (RN)
e-mail: mtma@mtmarchetti.com
http://www.mtmarchetti.com

PRODUZIONE MODULI ROTANTI



PAGINA NKM010-3-00

CUSCINETTI MAGGIORATI PER LAVORAZIONI PESANTI

Reinforced bearings for
heavy machining

Vergroesserte Lager fuer
schwerere Bearbeitungen

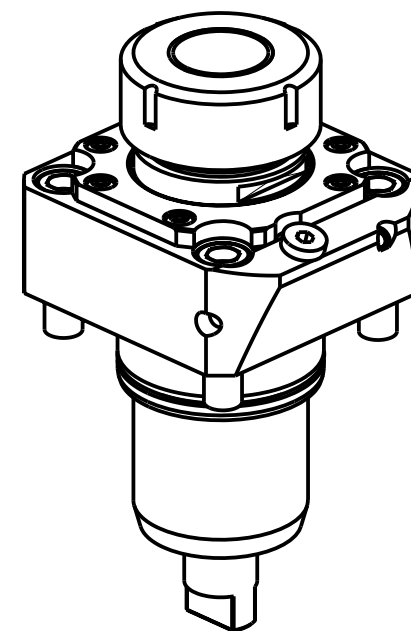
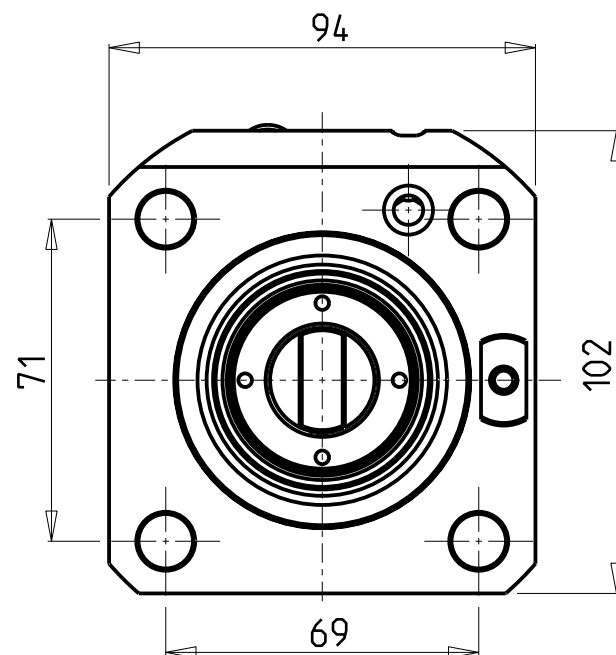
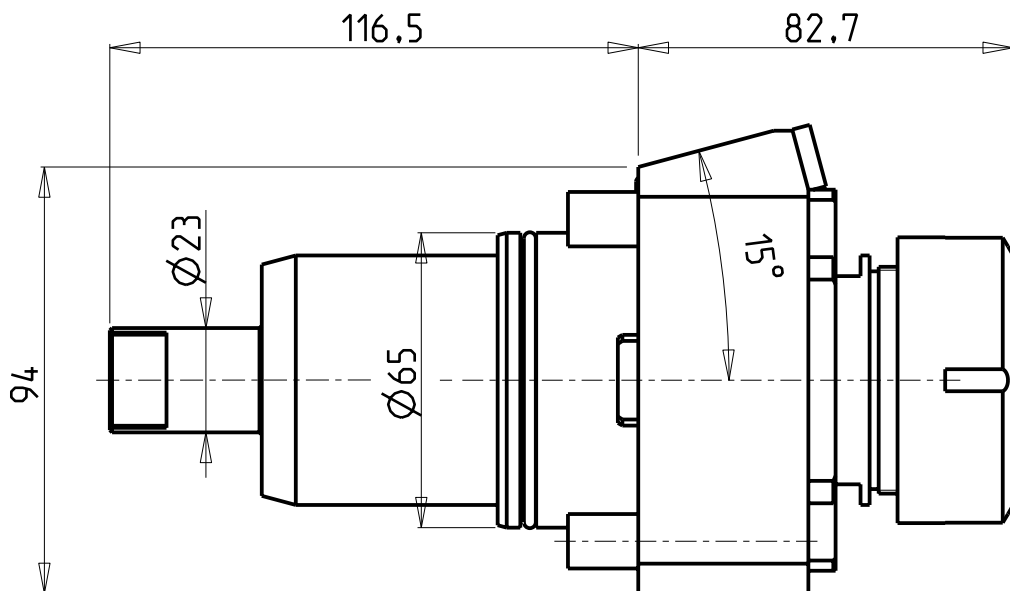

Cod. MT	Mandrino Spindle Spindel	I	RPM	Coppia Max Max Torque Max Drehmoment	Lubrificazione int. Coolant through Innenkueltung	Lubrificazione est. Ext. coolant Aussenkueltung	CHIAVI NON INCLUSE Keys not included Schluessel nicht einbegriffen	
NKM1480240	ER40	1:1	6000	80Nm	P=30bar	X	CHUB46	CHSTER40

NAKAMURA-TOME

WT300 - SC300 - SC300II - TMC200/300M - SUPER NTX - SUPER NTXL - TW20M/MY/MM/MMY/MYY 12 ST.

MODULO MOTORIZZATO RADIALE MAGGIORATO

Radial reinforced driven tool

Radial angetriebenes Werkzeug vergroessert

Subject to change without notice.

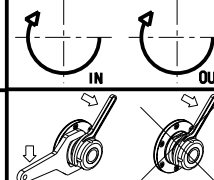

M.T. srl

Via Casino Albini 480
Tel. 0541/956034-957884
Fax 0541/956341
47842 S. GIOVANNI IN M. (RN)
e-mail: mtma@mtmarchetti.com
http://www.mtmarchetti.com

PRODUZIONE MODULI ROTANTI



PAGINA NKM020-3-00

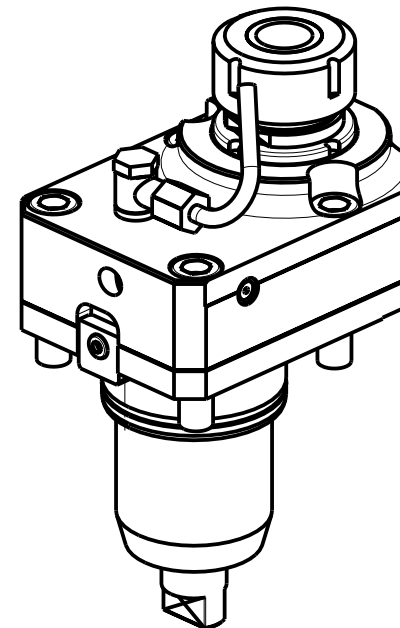
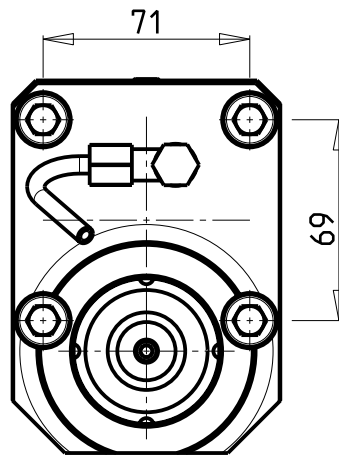
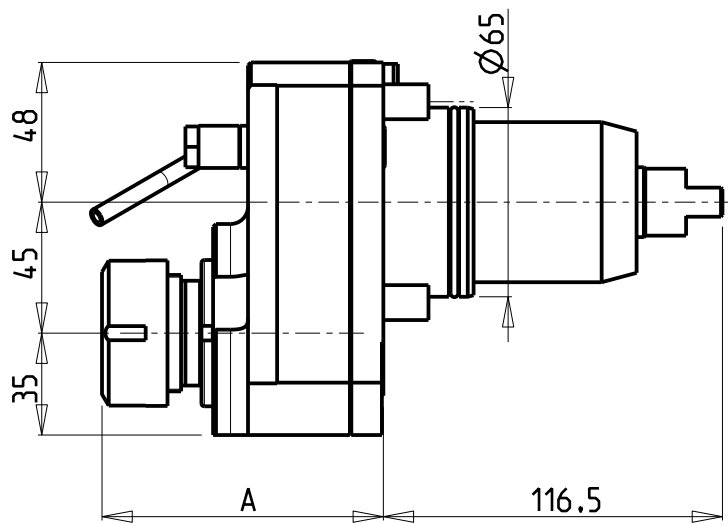
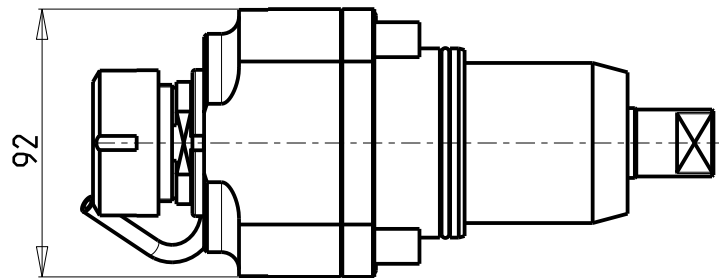

Cod. MT	Mandrino Spindle Spindel	I	RPM	Coppia Max Max Torque Max Drehmoment	Reversibile lato mandrino/contromandrino Reversible sub/main spindle side Umkehrbare Spindel-seite/ Gegenspindel-seite	Lubrificazione est. Ext. coolant Aussenkuehlung	A	CHIAVI NON INCLUSE Keys not included Schlüssel nicht einbegriffen
NKM0660132	ER32	1:2	12000	30Nm	X	X	96.6	CHSTER32 MNL0210007

NAKAMURA-TOME

WT300 - SC300 - SC30011 - TMC200/300M - SUPER NTX - SUPER NTXL - TW20M/MY/MM/MMY/MYY 12 ST.
TW30M/MY/MM/MMY/MYY 16 ST.

MODULO MOTORIZZATO RADIALE MOLTIPLICATO I=1:2 DISASSATO IN Z 45mm
Radial geared-up I=1:2 driven tool re-directed in Z by 45mm
Radial angetriebenes Werkzeug uebersetzt I=1:2 achsversetzt in Z um 45mm

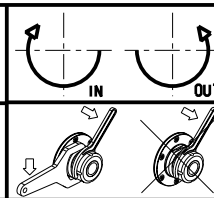

M.T. srl
Via Casino Albini 480
Tel. 0541/956034-957884
Fax 0541/956341
47842 S. GIOVANNI IN M. (RN)
e-mail: mtma@mtmarchetti.com
http://www.mtmarchetti.com

PRODUZIONE MODULI ROTANTI



PAGINA NKM030-3-30

Subject to change without notice.

10/2018

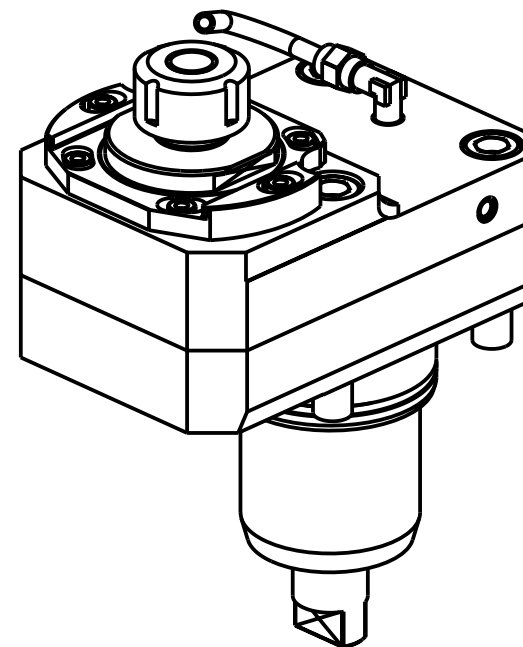
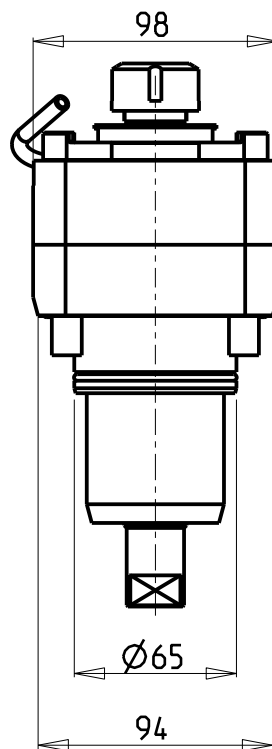
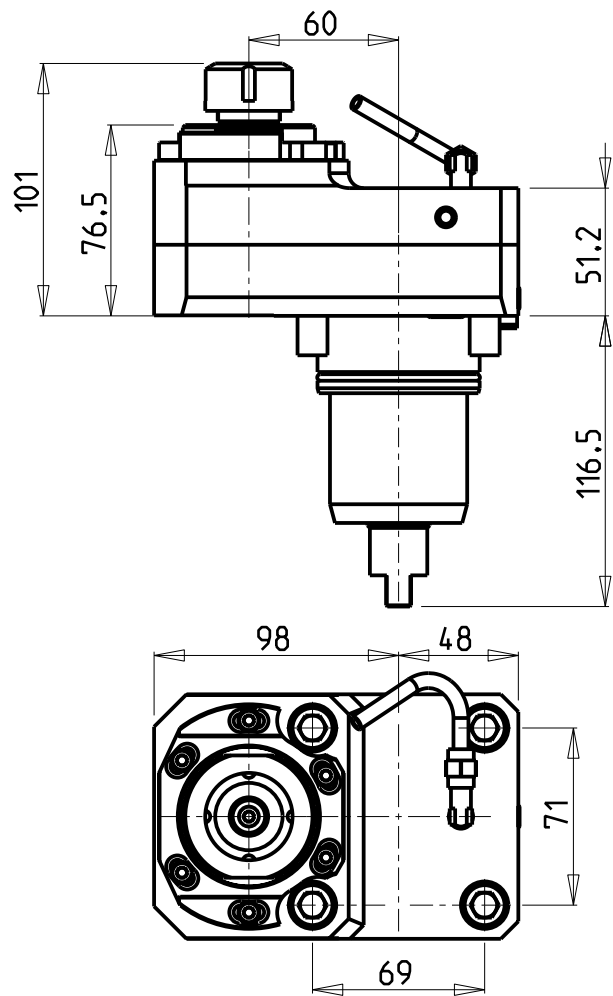

Cod. MT	Mandrino Spindle Spindel	I	RPM	Coppia Max Max Torque Max Drehmoment	Reversibile lato mandrino/contromandrino Reversible sub/main spindle side Umkehrbare Spindel-seite/ Gegenspindel-seite	Lubr.esterna Ext. coolant Aussenkuehlung	CHIAVI NON INCLUSE Keys not included Schluessel nicht einbegriffen
NKM1560320	ER20	1:1	6000	60Nm	X	X	CHSTER20 OKU0650004 •

- Chiave inclusa
- Key included
- Schluessel inbegriffen

NAKAMURA-TOME

WT300 - SC300 - SC30011 - TMC200/300M - SUPER NTX - SUPER NTXL - TW20M/MY/MM/MYY/MYY 12 ST.
TW30M/MY/MM/MYY/MYY 16 ST.

MODULO MOTORIZZATO RADIALE DISASSATO IN Z 60mm

Radial driven tool re-directed in Z by 60mm

Radial angetriebenes Werkzeug achsversetzt in Z um 60mm

Subject to change without notice.

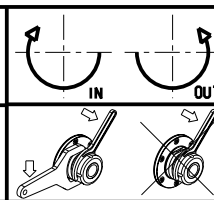

M.T. srl
Via Casino Albini 480
Tel. 0541/956034-957884
Fax 0541/956341
47842 S. GIOVANNI IN M. (RN)
e-mail: mtma@mtmarchetti.com
http://www.mtmarchetti.com

PRODUZIONE MODULI ROTANTI



PAGINA NKM033-3-10

ATTENZIONE - ATTENTION - ACHTUNG

- Per lo smontaggio degli utensili utilizzare sempre la chiave di contrasto come indicato nel manuale d'uso.
- For disassembly of the tools use always the contrast key as mentioned in the user instructions.
- Fuer das Abmontieren der Werkzeuge immer den Gegenschlüssel benutzen wie in der Bedienungsanleitung erwaeht.

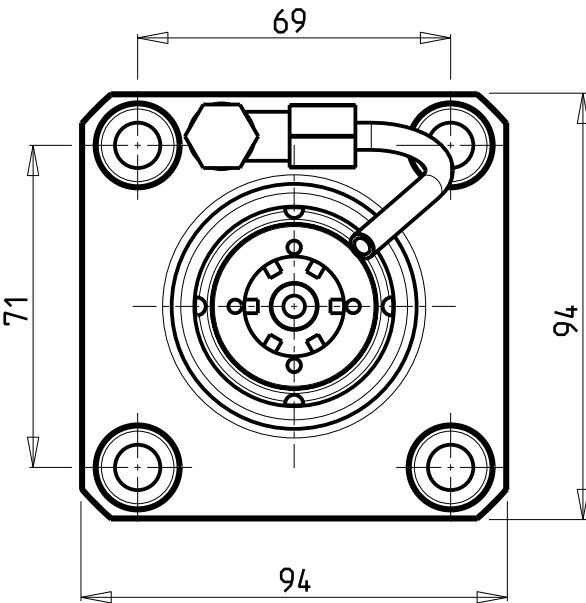
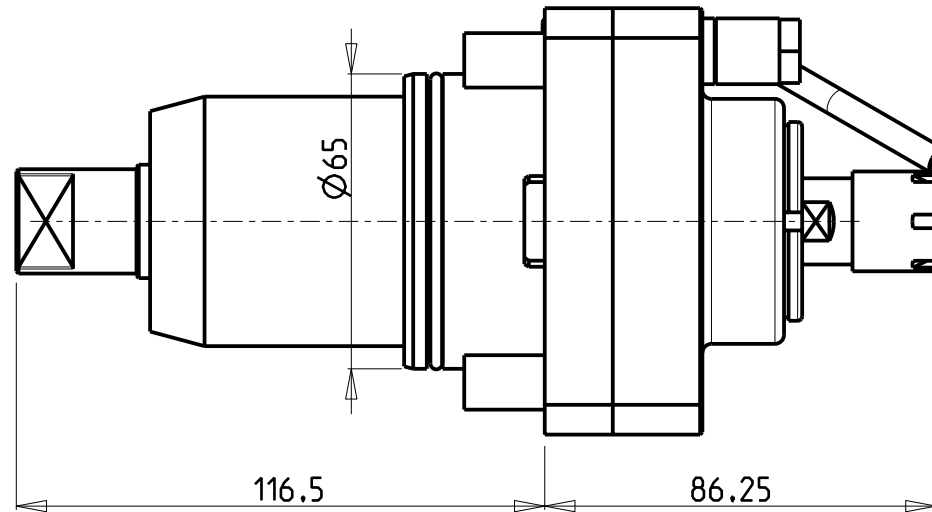
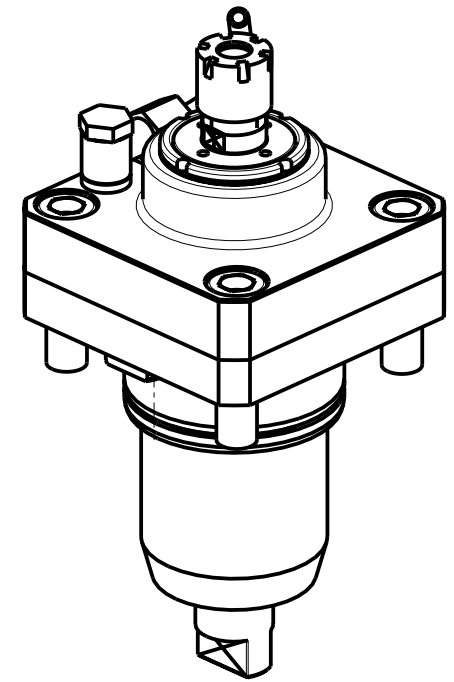

ATTENZIONE - ATTENTION - ACHTUNG

- PRIMA DI UTILIZZARE IL MOTORIZZATO CONSULTARE LE ISTRUZIONI ALLEGATE!
- BEFORE USING THE DRIVEN TOOL, PLEASE CHECK THE ENCLOSED INSTRUCTION SHEET!
- VOR DER BENUTZUNG DES ANGETRIEBENEN WERKZEUGES, DIE BEILIEGENDEN INSTRUKTIONEN DURCHLESEN!

Cod. MT	Mandrino Spindle Spindel	I	RPM	Coppia Max Max Torque Max Drehmoment	Lubrificazione est. Ext. coolant Aussenkuehlung	CHIAVI INCLUSE Keys included Schluessel einbegriffen	
NKM0680116	ER16	1:3	18000	10Nm	X	CHUB17	CHMNER16

NAKAMURA - TOME

WT300 - SC300 - SC30011 - TMC200/300M - SUPER NTX - SUPER NTXL - TW20M/MY/MM/MMY/MYY 12 ST.
TW30M/MY/MM/MMY/MYY 16 ST.

MODULO MOTORIZZATO RADIALE MOLTIPLICATO I=1:3

Radial geared-up I=1:3 driven tool

Radial angetriebenes Werkzeug uebersetzt I=1:3

Subject to change without notice.

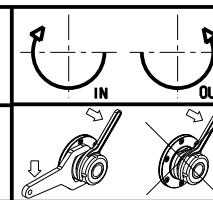

M.T. srl

Via Casino Albini 480
Tel. 0541/956034-957884
Fax 0541/956341
47842 S. GIOVANNI IN M. (RN)
e-mail: mtma@mtmarchetti.com..
http://www.mtmarchetti.com

PRODUZIONE MODULI ROTANTI



PAGINA NKM055-3-00

ATTENZIONE - ATTENTION - ACHTUNG

- Per lo smontaggio degli utensili utilizzare sempre la chiave di contrasto come indicato nel manuale d'uso.
- For disassembly of the tools use always the contrast key as mentioned in the user instructions.
- Fuer das Abmontieren der Werkzeuge immer den Gegenschlüssel benutzen wie in der Bedienungsanleitung erwaehnt.

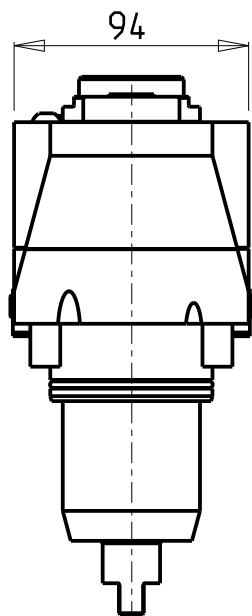
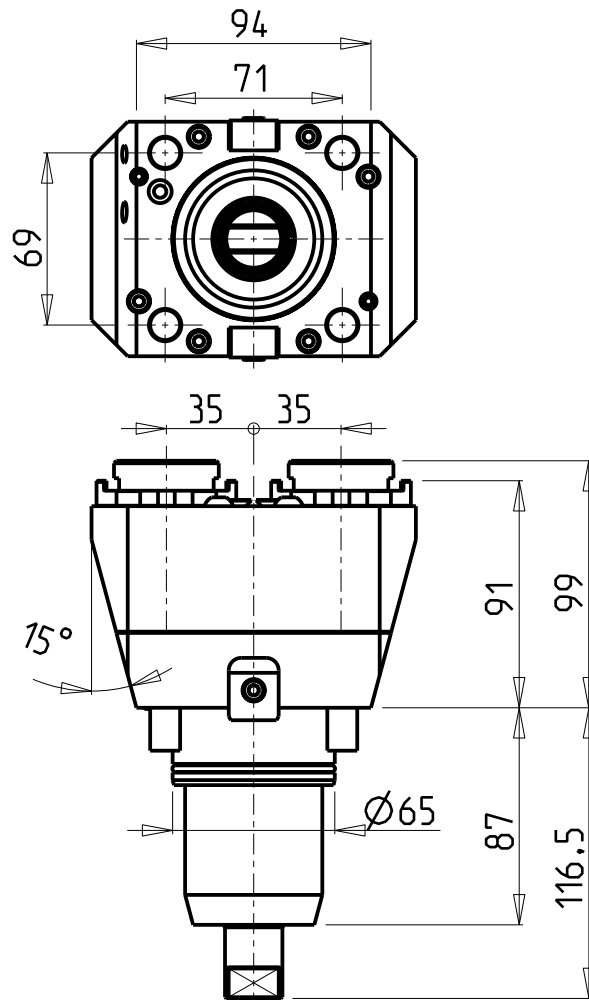

- Chiave inclusa
- Key included
- Schluessel inbegriffen

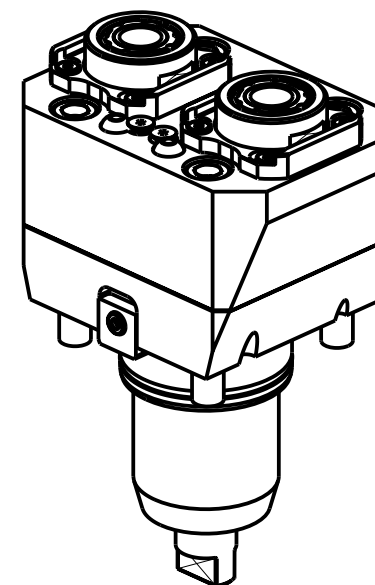

Cod. MT	Mandrino Spindle Spindel	I	RPM	Coppia Max Max Torque Max Drehmoment	Lubrificazione est. Ext. coolant Aussenkuehlung	CHIAVI NON INCLUSE Keys not included Schluessel nicht einbegriffen		
NKM1540325	ERA25	1:1	6000	50Nm	X	CHUB27	CHTAER25ZC *	OKU0290009 *

NAKAMURA-TOME

WT300 - SC300 - SC300II - TW20MY/MMY/MYY 12 ST. - TW30MY/MMY/MYY 16 ST.

MODULO MOTORIZZATO RADIALE 2 USCITE IN Y
Radial single side twin head driven tool in Y
Radial angetriebenes Werkzeug 2 Ausgaenge in Y

Subject to change without notice.

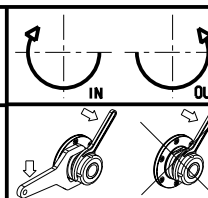

M.T. srl
Via Casino Albini 480
Tel. 0541/956034-957884
Fax 0541/956341
47842 S. GIOVANNI IN M. (RN)
e-mail: mtma@mtmarchetti.com
http://www.mtmarchetti.com

PRODUZIONE MODULI ROTANTI



PAGINA NKM080-3-00

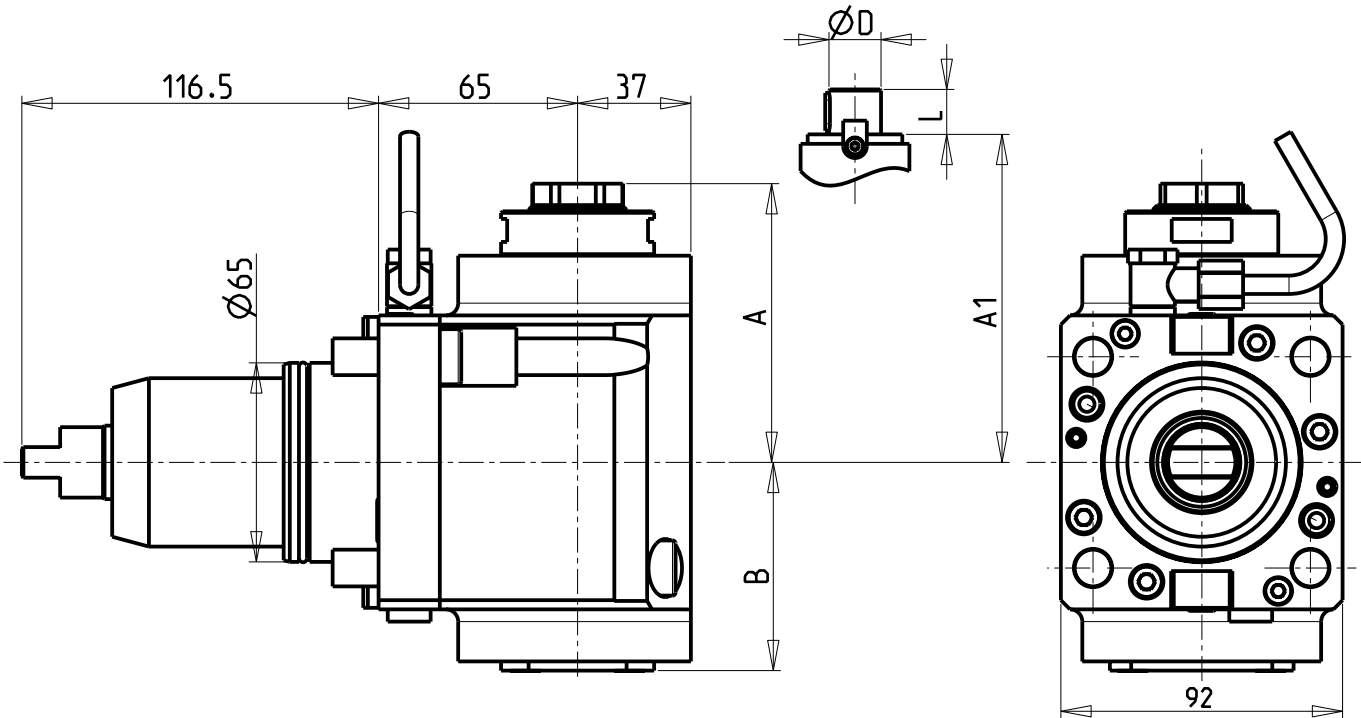

ATTENZIONE - ATTENTION - ACHTUNG

- Per lo smontaggio degli utensili utilizzare sempre la chiave di contrasto come indicato nel manuale d'uso.
- For disassembly of the tools use always the contrast key as mentioned in the user instructions.
- Fuer das Abmontieren der Werkzeuge immer den Gegenschlüssel benutzen wie in der Bedienungsanleitung erwaeht.

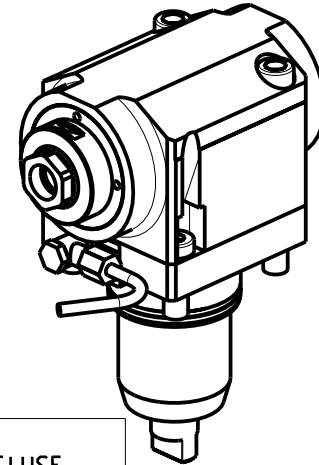

- Chiave inclusa
- Key included
- Schluesel inbegriffen

Cod. MT	Mandrino Spindel	I	RPM	Coppia Max Max Torque Max Drehmoment	Reversibile lato mandrino/contromandrino Reversible sub/main spindle side Umkehrbare Spindel-seite/ Gegenspindel-seite	Lubr. interna Coolant through Innenkuehlung	Lubr. esterna Ext. coolant Aussenkuehlung	A	A1	B	D	L	CHIAVI NON INCLUDE Keys not included Schluesel nicht einbegriffen	
NKM0260125	ER A 25	1:1	6000	70Nm	X	-	X	91.03	-	68	-	-	CHUB46	CHUB27
NKM0260132	ER A 32	1:1	6000	70Nm	X	-	X	94.53	-	68	-	-	CHUB46	CHUB32
NKM0260140	ER40	1:1	6000	70Nm	X	-	X	108.16	-	68	-	-	CHUB46	CHSTER40
NKM0260225	ER A 25	1:1	6000	70Nm	X	P=70bar	X	91.03	-	91.5	-	-	CHUB46	CHUB27
NKM0260232	ER A 32	1:1	6000	70Nm	X	P=70bar	X	94.53	-	91.5	-	-	CHUB46	CHUB32
NKM0260240	ER40	1:1	6000	70Nm	X	P=70bar	X	108.16	-	79	-	-	CHUB46	CHSTER40
NKM0262219	Ø22x19	1:1	6000	70Nm	X	-	X	-	80	68	22	19	CHUB46	CH_VTCROCE_M10 *

NAKAMURA - TOME

WT300 - SC300 - SC30011 - TMC200/300M - SUPER NTX - SUPER NTXL - TW20M/MY/MM/MMY/MYY 12 ST.
TW30M/MY/MM/MMY/MYY 16 ST.

MODULO MOTORIZZATO ASSIALE H=65mm

Axial driven tool H=65mm

Axial angetriebenes Werkzeug H=65mm

Subject to change without notice.

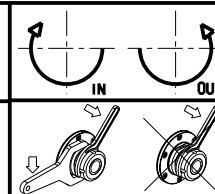

M.T. srl

Via Casino Albini 480
Tel. 0541/956034-957884
Fax 0541/956341
47842 S. GIOVANNI IN M. (RN)
e-mail: mtma@tmarchetti.com
http://www.tmmarchetti.com

PRODUZIONE MODULI ROTANTI



PAGINA NKM150-3-10

ATTENZIONE - ATTENTION - ACHTUNG

- Per lo smontaggio degli utensili utilizzare sempre la chiave di contrasto come indicato nel manuale d'uso.
- For disassembly of the tools use always the contrast key as mentioned in the user instructions.
- Fuer das Abmontieren der Werkzeuge immer den Gegenschlüssel benutzen wie in der Bedienungsanleitung erwäehnt.

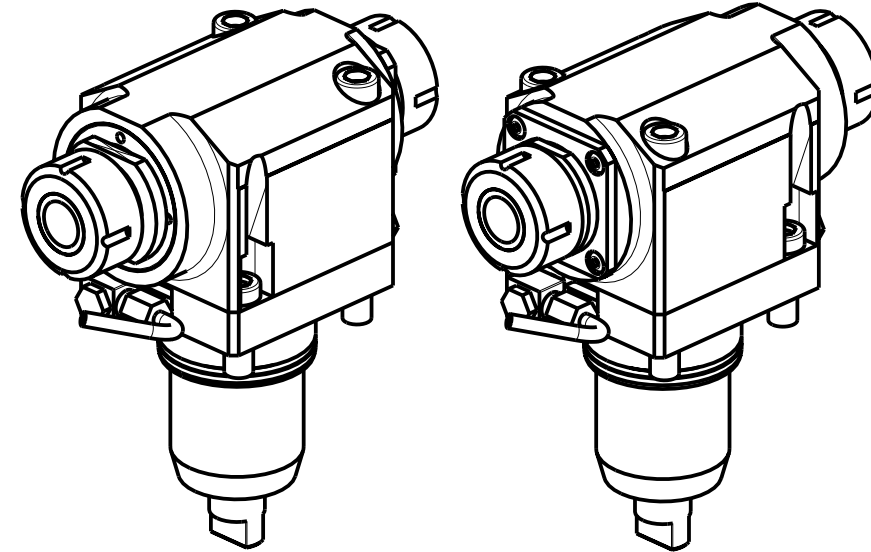
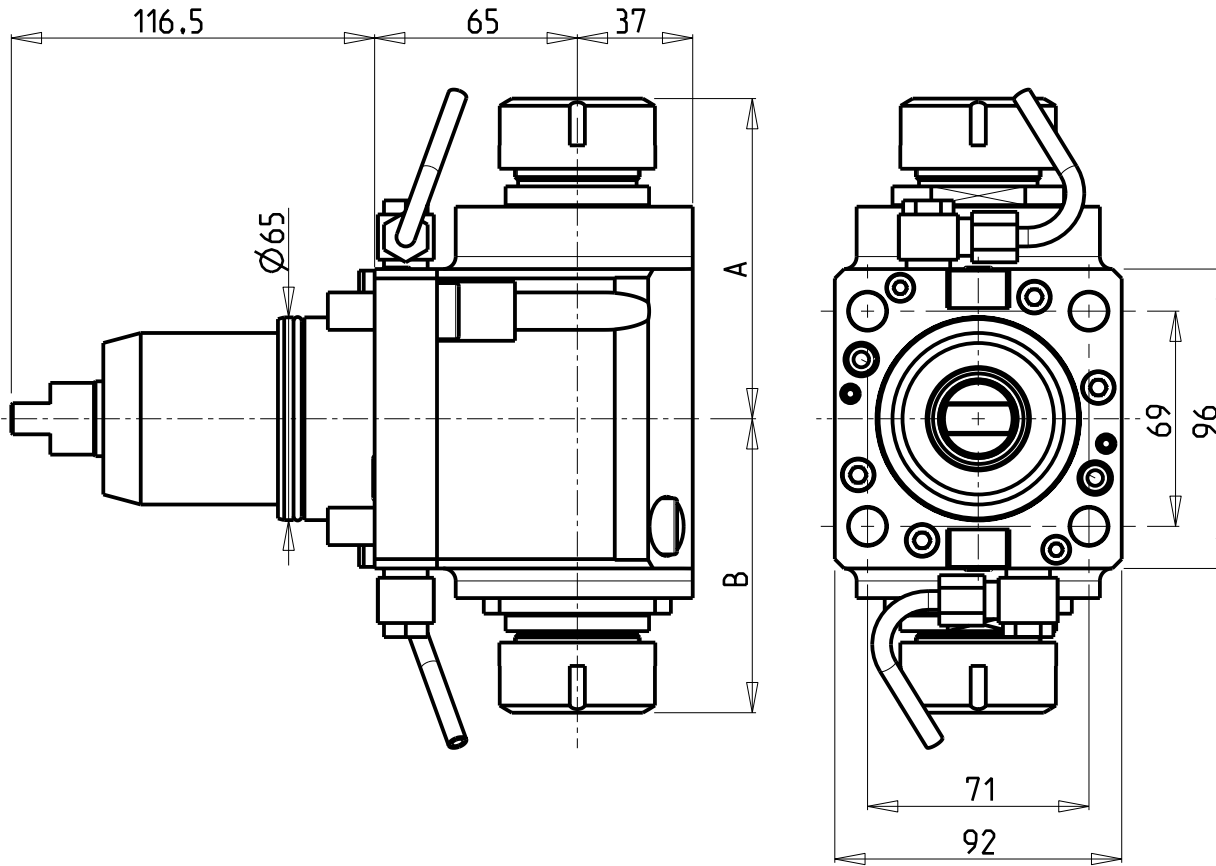

Cod. MT	Mandrino Spindle Spindel	I	RPM	Coppia Max Max Torque Max Drehmoment	Reversibile lato mandrino/contromandrino Reversible sub/main spindle side Umkehrbare Spindel-seite/ Gegenspindel-seite	Lubrificazione est. Ext. coolant Aussenkuehlung	A	B	CHIAVI NON INCLUSE Keys not included Schluesssel nicht einbegriffen	
NKM0590232	ER32+ER32	1:1	6000	70Nm	X	X	102.66	94.26	CHSTER32	CHUB46

NAKAMURA - TOME

WT300 - SC300 - SC30011 - TMC200/300M - SUPER NTX - SUPER NTXL - TW20M/MY/MM/MMY/MMYY 12 ST.
TW30M/MY/MM/MMY/MMYY 16 ST.

MODULO MOTORIZZATO ASSIALE BISPORGENTE H=65mm

Axial opposite face twin driven tool H=65mm

Axial angetriebenes Werkzeug halb vorspringend H=65mm

Subject to change without notice.

M.T. srl

Via Casino Albini 480
Tel. 0541/956034-957884
Fax 0541/956341
47842 S. GIOVANNI IN M. (RN)
e-mail: mtma@mtmarchetti.com
http://www.mtmarchetti.com

PRODUZIONE MODULI ROTANTI



PAGINA NKM240-3-10

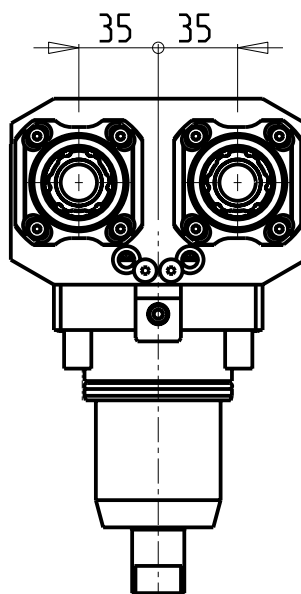
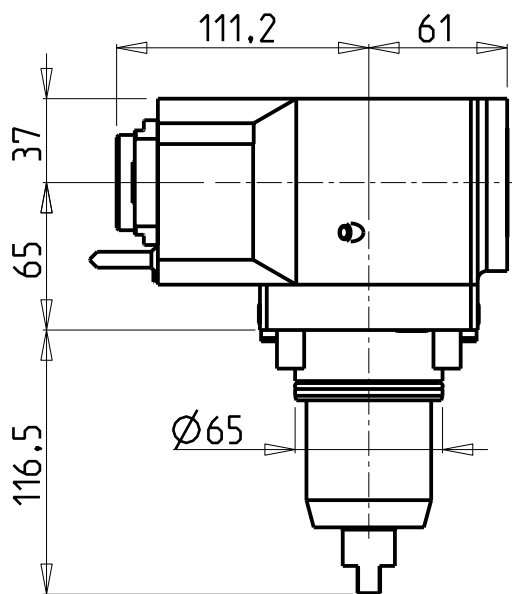
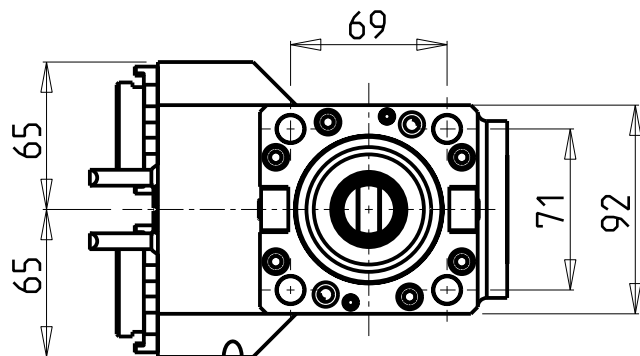

ATTENZIONE - ATTENTION - ACHTUNG

- Per lo smontaggio degli utensili utilizzare sempre la chiave di contrasto come indicato nel manuale d'uso.
- For disassembly of the tools use always the contrast key as mentioned in the user instructions.
- Fuer das Abmontieren der Werkzeuge immer den Gegenschlüssel benutzen wie in der Bedienungsanleitung erwaehnt.

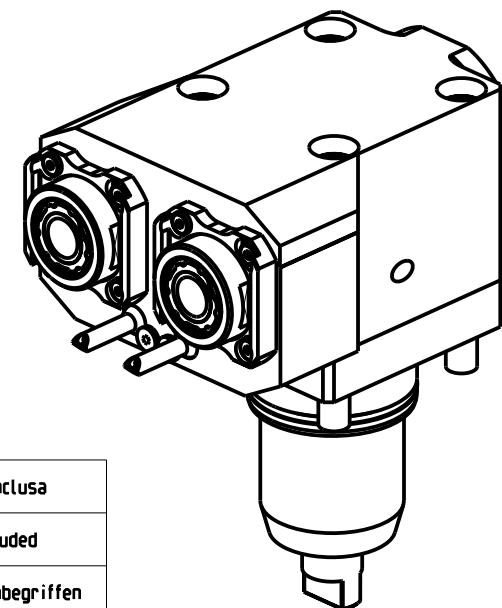

- Chiave inclusa
- Key included
- Schluessel inbegriffen

Cod. MT	Mandrino Spindle Spindel	I	RPM	Coppia Max Max Torque Max Drehmoment	Reversibile lato mandrino/contromandrino Reversible sub/main spindle side Umkehrbare Spindel-seite/ Gegenspindel-seite	Lubrificazione est. Ext. coolant Aussenkuehlung	CHIAVI NON INCLUSE Keys not included Schluessel nicht einbegriffen		
NKM1550325	ERA25	1:1	6000	50Nm	X	X	CHUB27	CHTAER25ZC *	OKU0290009 *

NAKAMURA-TOME

WT300 - SC300 - SC300II - TW20MY/MMY/MYY 12 ST. - TW30MY/MMY/MYY 16 ST.

MODULO MOTORIZZATO ASSIALE 2 USCITE IN Y
Axial single side twin head driven tool in Y
Axial angetriebenes Werkzeug 2 Ausgaenge in Y

Subject to change without notice.

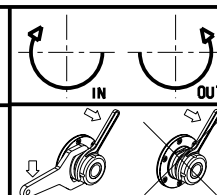

M.T. srl

Via Casino Albini 480
Tel. 0541/956034-957884
Fax 0541/956341
47842 S. GIOVANNI IN M. (RN)
e-mail: mtma@mtmarchetti.com
http://www.mtmarchetti.com

PRODUZIONE MODULI ROTANTI



PAGINA NKM260-3-10

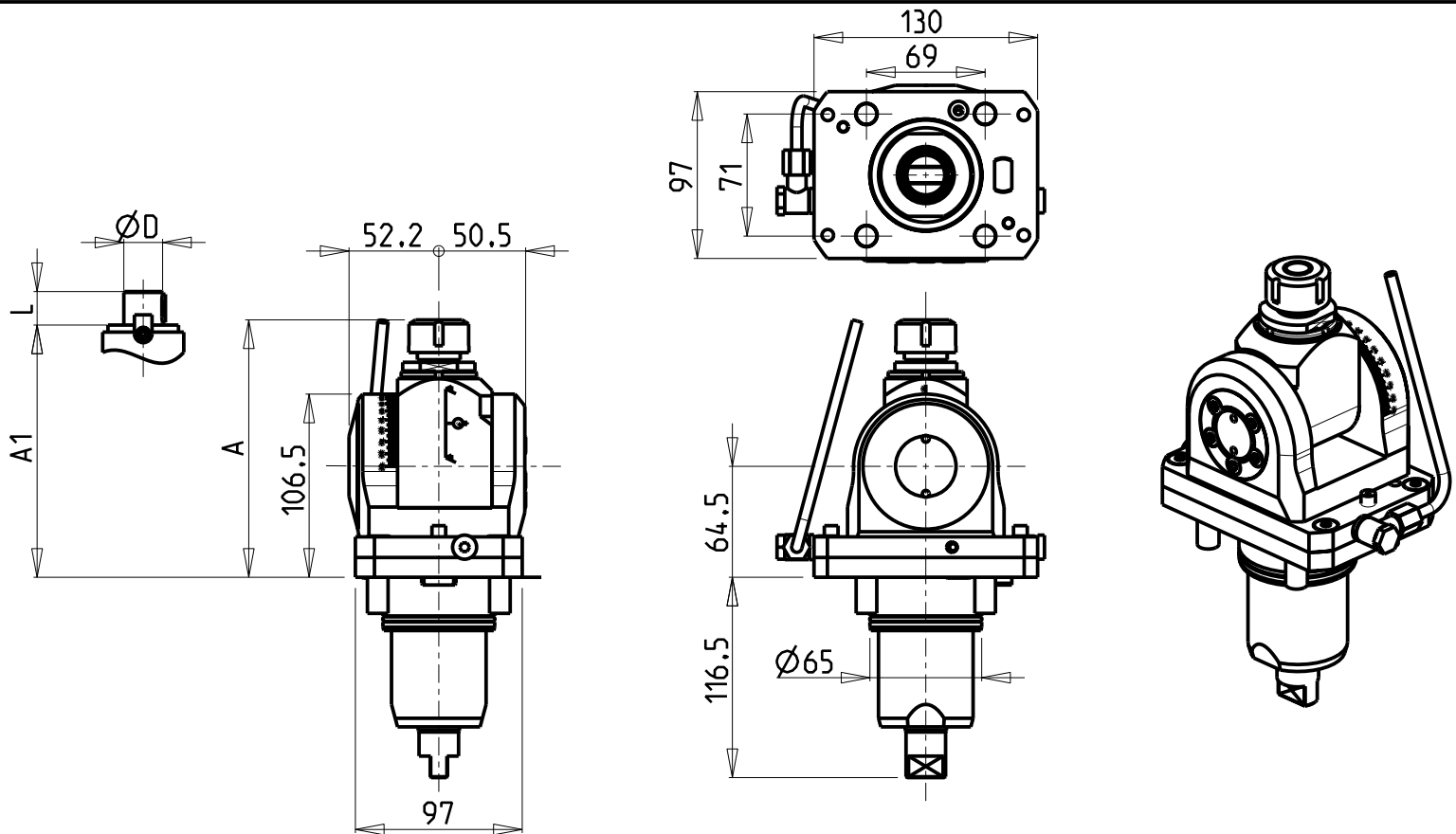

ATTENZIONE - ATTENTION - ACHTUNG

- Per lo smontaggio degli utensili utilizzare sempre la chiave di contrasto come indicato nel manuale d'uso.
- For disassembly of the tools use always the contrast key as mentioned in the user instructions.
- Fuer das Abmontieren der Werkzeuge immer den Gegenschlüssel benutzen wie in der Bedienungsanleitung erwaeht.

ATTENZIONE - ATTENTION - ACHTUNG

- Verificare la tabella sottostante per possibile interferenza su alcuni modelli di macchine
- Please check the table below for possible interferences on some machine models
- Die untenstehende tabelle unbedingt auf eventuelle interferenzen auf eingen maschinen modellen überprüfen

Cod. MT	Mandrino Spindle Spindel	I	RPM	Coppia Max Max Torque Max Drehmoment	Lubrificazione est. Ext. coolant Aussenkuehlung	A	A1	D	L	CHIAVI INCLUSE Keys included Schluessel inbegriffen	
NKM1270120	ER20	1:1	6000	40Nm	X	149.66	-	-	-	CHUB36	CHSTER20
NKM1270125	ER25	1:1	6000	40Nm	X	150.66	-	-	-	CHUB36	CHSTER25
NKM1270516	Ø16x17	1:1	6000	40Nm	X	-	129.5	16	17	CHUB36	CH_VTCROCE_M08
NKM1270519	Ø3/4"x3/4"	1:1	6000	40Nm	X	-	129.5	3/4"	3/4"	CHUB36	CH_VTCROCE_M08
NKM1270522	Ø22x19	1:1	6000	40Nm	X	-	130.5	22	19	CHUB36	CH_VTCROCE_M10

NAKAMURA-TOME

WT300 - SC300 - SC30011 - TMC200/300M - SUPER NTX - SUPER NTXL - TW20M/MY/MM/MMY/MYY 12 ST.
TW30M/MY/MM/MMY/MYY 16 ST.

MODULO MOTORIZZATO ORIENTABILE ±90°

±90° adjustable angle driven tool

Angetriebenes Werkzeug schwenkbar ±90°

Subject to change without notice.

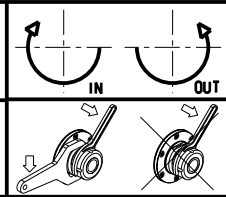

M.T. srl

Via Casino Albini 480
Tel. 0541/956034-957884
Fax 0541/956341

47842 S. GIOVANNI IN M. (RN)
e-mail: mtma@mtmarchetti.com
http://www.mtmarchetti.com

PRODUZIONE MODULI ROTANTI



PAGINA NKM333-3-00

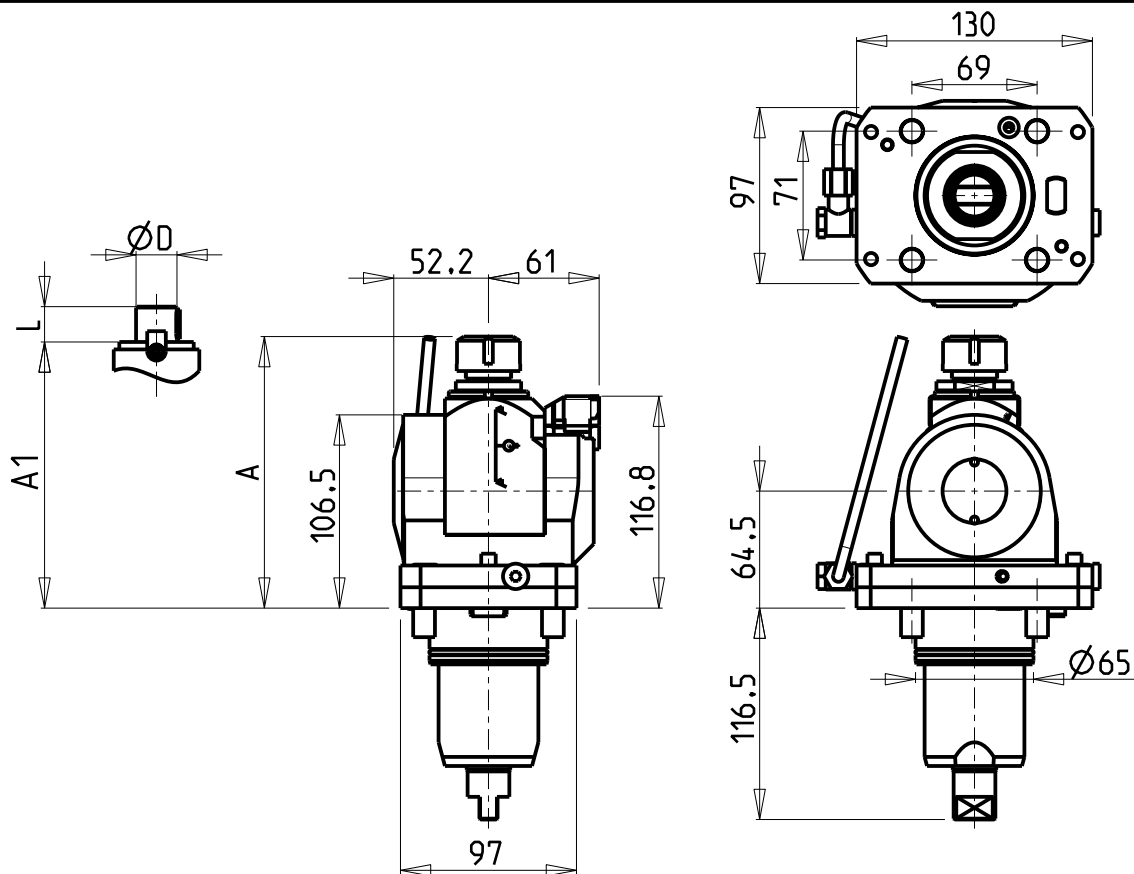

ATTENZIONE - ATTENTION - ACHTUNG

- Per lo smontaggio degli utensili utilizzare sempre la chiave di contrasto come indicato nel manuale d'uso.
- For disassembly of the tools use always the contrast key as mentioned in the user instructions.
- Fuer das Abmontieren der Werkzeuge immer den Gegenschlüssel benutzen wie in der Bedienungsanleitung erwaeht.

ATTENZIONE - ATTENTION - ACHTUNG

- Verificare la tabella sottostante per possibile interferenza su alcuni modelli di macchine
- Please check the table below for possible interferences on some machine models
- Die untenstehende tabelle unbedingt auf eventuelle interferenzen auf eingen maschinen modellen überprüfen

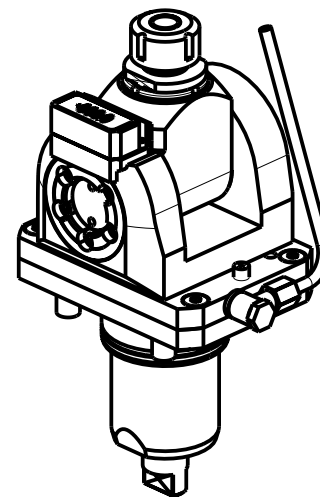

Cod. MT	Mandrino Spindle Spindel	I	RPM	Coppia Max Max Torque Max Drehmoment	Lubrificazione est. Ext. coolant Aussenkuehlung	A	A1	D	L	CHIAVI INCLUSE Keys included Schluessel inbegriffen	
NKM1230120	ER20	1:1	6000	40Nm	X	149.66	-	-	-	CHUB36	CHSTER20
NKM1230125	ER25	1:1	6000	40Nm	X	150.66	-	-	-	CHUB36	CHSTER25
NKM1230516	Ø16x17	1:1	6000	40Nm	X	-	129.5	16	17	CHUB36	CH_VTCROCE_M08
NKM1230519	Ø3/4"x3/4"	1:1	6000	40Nm	X	-	129.5	3/4"	3/4"	CHUB36	CH_VTCROCE_M08
NKM1230522	Ø22x19	1:1	6000	40Nm	X	-	130.5	22	19	CHUB36	CH_VTCROCE_M10

NAKAMURA-TOME

WT300 - SC300 - SC30011 - TMC200/300M - SUPER NTX - SUPER NTXL - TW20M/MY/MM/MMY/MMYY 12 ST.
TW30M/MY/MM/MMY/MMYY 16 ST.

MODULO MOTORIZZATO ORIENTABILE ±90° CON NONIO DIGITALE

±90° adjustable angle driven tool with digital display

Angetriebenes Werkzeug schwenkbar ±90° mit digital display

Subject to change without notice.

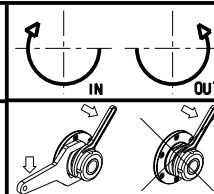

M.T. srl

Via Casino Albini 480
Tel. 0541/956034-957884
Fax 0541/956341
47842 S. GIOVANNI IN M. (RN)
e-mail: mtma@mtmarchetti.com
http://www.mtmarchetti.com

PRODUZIONE MODULI ROTANTI



PAGINA NKM333-3-01

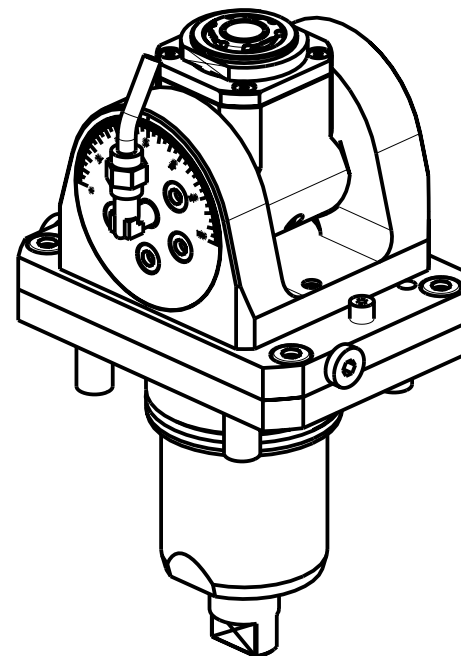
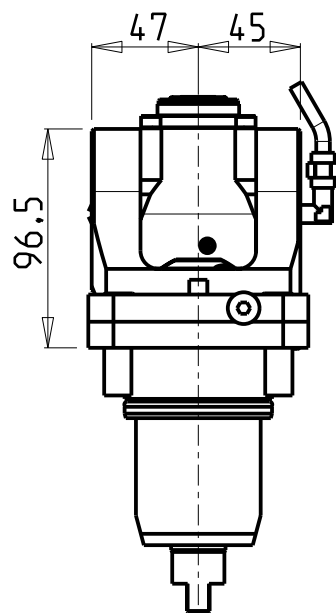
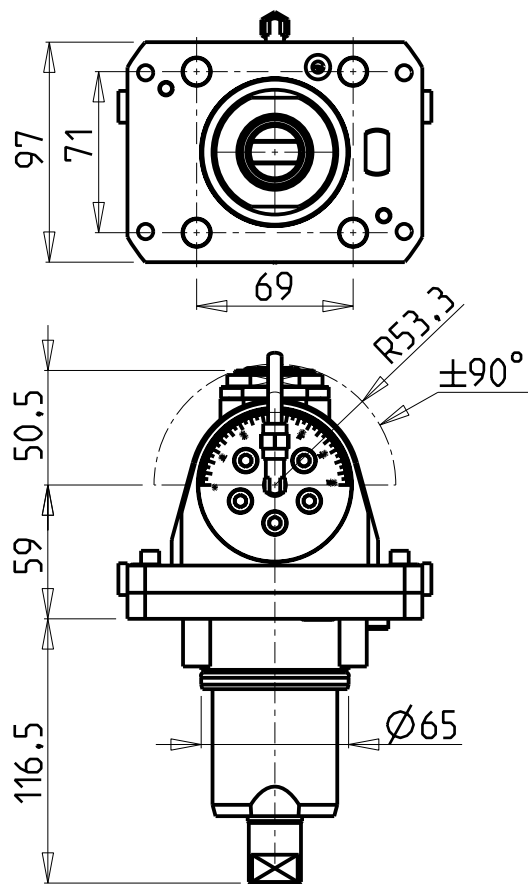

ATTENZIONE - ATTENTION - ACHTUNG

- Per lo smontaggio degli utensili utilizzare sempre la chiave di contrasto come indicato nel manuale d'uso.
- For disassembly of the tools use always the contrast key as mentioned in the user instructions.
- Fuer das Abmontieren der Werkzeuge immer den Gegenschlüssel benutzen wie in der Bedienungsanleitung erwaeht.

ATTENZIONE - ATTENTION - ACHTUNG

- Verificare la tabella sottostante per possibile interferenza su alcuni modelli di macchine
- Please check the table below for possible interferences on some machine models
- Die untenstehende tabelle unbedingt auf eventuelle interferenzen auf eingen maschinen modellen überprüfen

Cod. MT	Mandrino Spindle Spindel	I	RPM	Coppia Max Max Torque Max Drehmoment	Lubr.interna Coolant through Innenkuehlung	Lubrificazione est. Ext. coolant Aussenkuehlung	CHIAVI INCLUSE Keys included Schluessel inbegriffen				
							CHUB22	CHUB36	CHESL05	CHESL08	CHTAER20ZC
NKM0800120	ERA20	1:1	6000	30Nm		X	CHUB22	CHUB36	CHESL05	CHESL08	CHTAER20ZC
NKM0800220	ERA20	1:1	6000	30Nm	P=70bar	X	CHUB22	CHUB36	CHESL05	CHESL08	CHTAER20ZC

NAKAMURA-TOME

WT300 - SC300 - SC30011 - TMC200/300M - SUPER NTX - SUPER NTXL - TW20M/MY/MM/MMY/MMYY 12 ST.
TW30M/MY/MM/MMY/MMYY 16 ST.

MODULO MOTORIZZATO ORIENTABILE ±90°

±90° adjustable angle driven tool

Angetriebenes Werkzeug schwenkbar ±90°

Subject to change without notice.

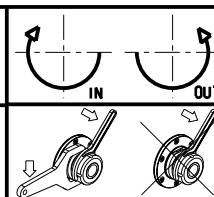

M.T. srl

Via Casino Albini 480
Tel. 0541/956034-957884
Fax 0541/956341
47842 S. GIOVANNI IN M. (RN)
e-mail: mtma@mtmarchetti.com
http://www.mtmarchetti.com

PRODUZIONE MODULI ROTANTI



PAGINA NKM335-3-00

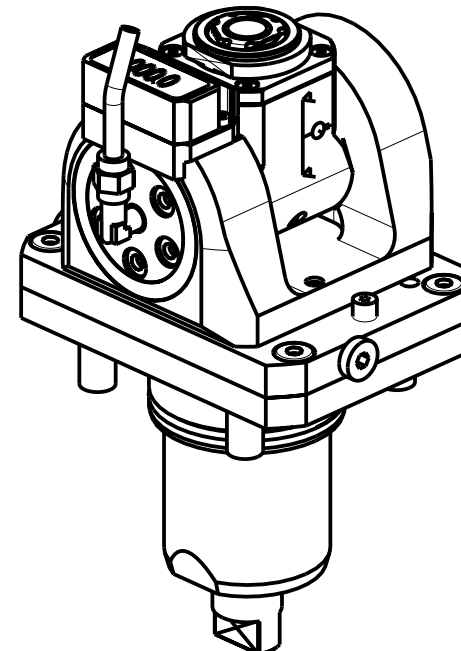
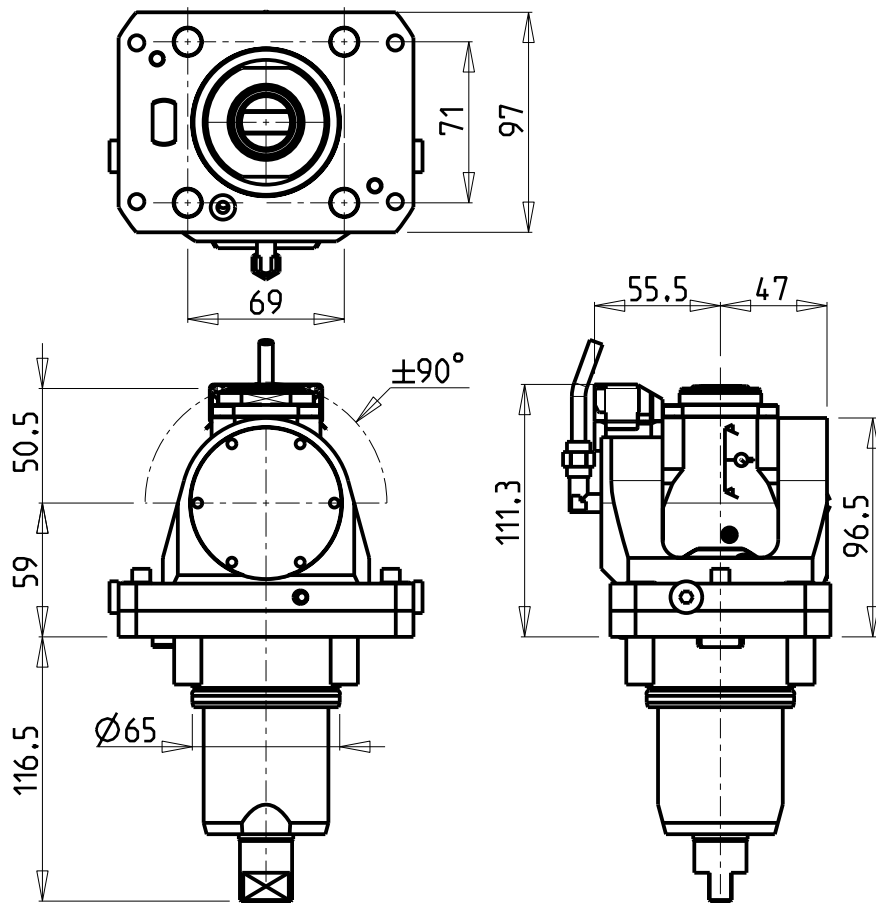

ATTENZIONE - ATTENTION - ACHTUNG

- Per lo smontaggio degli utensili utilizzare sempre la chiave di contrasto come indicato nel manuale d'uso.
- For disassembly of the tools use always the contrast key as mentioned in the user instructions.
- Fuer das Abmontieren der Werkzeuge immer den Gegenschlüssel benutzen wie in der Bedienungsanleitung erwaehtnt.

ATTENZIONE - ATTENTION - ACHTUNG

- Verificare la tabella sottostante per possibile interferenza su alcuni modelli di macchine
- Please check the table below for possible interferences on some machine models
- Die untenstehende tabelle unbedingt auf eventuelle interferenzen auf eingen maschinen modellen überprüfen

Cod. MT	Mandrino Spindle Spindel	I	RPM	Coppia Max Max Torque Max Drehmoment	Lubr.interna Coolant through Innenkuehlung	Lubrificazione est. Ext. coolant Aussenkuehlung	CHIAVI INCLUSE Keys included Schluessel inbegriffen				
							CHUB22	CHUB36	CHESL05	CHESL08	CHTAER20ZC
NKM0805120	ERA20	1:1	6000	30Nm	-	X	CHUB22	CHUB36	CHESL05	CHESL08	CHTAER20ZC
NKM0805220	ERA20	1:1	6000	30Nm	P=70bar	X	CHUB22	CHUB36	CHESL05	CHESL08	CHTAER20ZC

NAKAMURA-TOME
 WT300 - SC300 - SC30011 - TMC200/300M - SUPER NTX - SUPER NTXL - TW20M/MY/MM/MMY/MMYY 12 ST.
 TW30M/MY/MM/MMY/MMYY 16 ST.

MODULO MOTORIZZATO ORIENTABILE ±90° CON NONIO DIGITALE
 ±90° adjustable angle driven tool with digital display
 Angetriebenes Werkzeug schwenkbar ±90° mit digital display

Subject to change without notice.

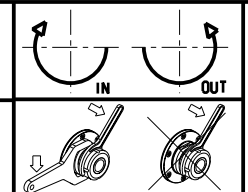

M.T. srl
 Via Casino Albini 480
 Tel. 0541/956034-957884
 Fax 0541/956341
 47842 S. GIOVANNI IN M. (RN)
 e-mail: mtma@mtmarchetti.com
 http://www.mtmarchetti.com

PRODUZIONE MODULI ROTANTI

PAGINA NKM335-3-01

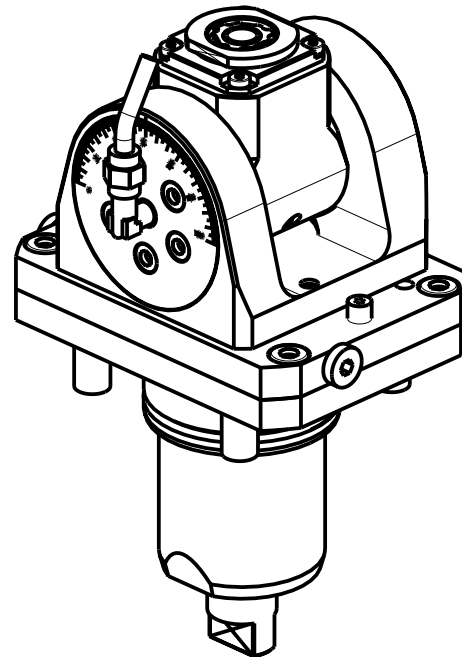
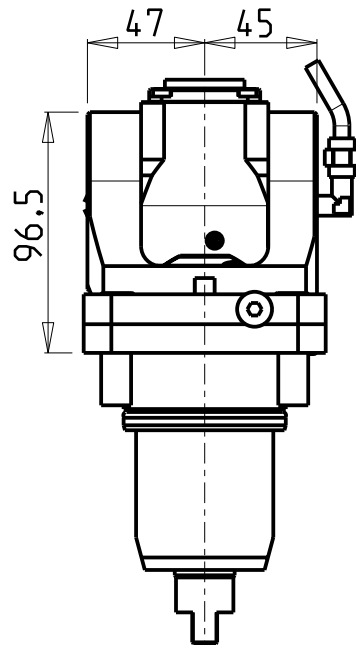
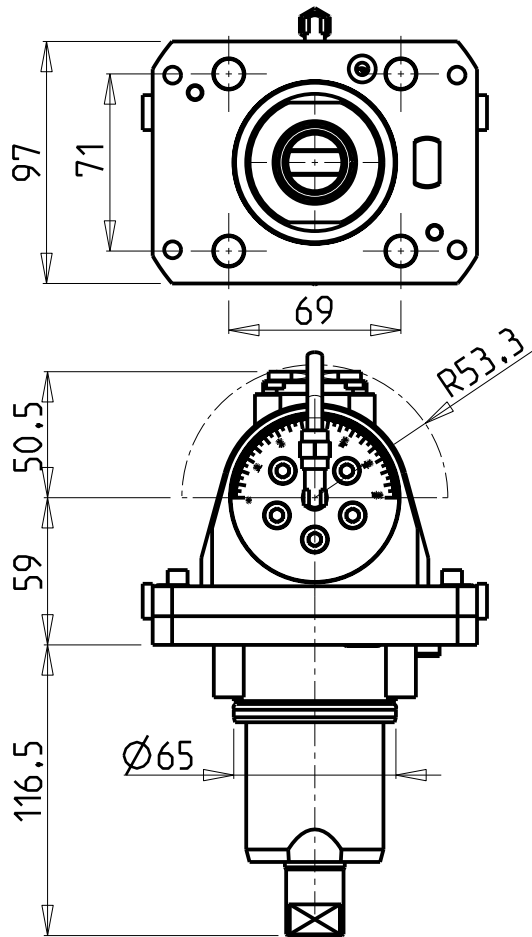

ATTENZIONE - ATTENTION - ACHTUNG

- Per lo smontaggio degli utensili utilizzare sempre la chiave di contrasto come indicato nel manuale d'uso.
- For disassembly of the tools use always the contrast key as mentioned in the user instructions.
- Fuer das Abmontieren der Werkzeuge immer den Gegenschlüssel benutzen wie in der Bedienungsanleitung erwaeht.

ATTENZIONE - ATTENTION - ACHTUNG

- Verificare la tabella sottostante per possibile interferenza su alcuni modelli di macchine
- Please check the table below for possible interferences on some machine models
- Die untenstehende tabelle unbedingt auf eventuelle interferenzen auf eingen maschinen modellen ueberpruefen

Cod. MT	Mandrino Spindle Spindel	I	RPM	Coppia Max Max Torque Max Drehmoment	Lubr.interna Coolant through Innenkuehlung	Lubrificazione est. Ext. coolant Aussenkuehlung	CHIAVI INCLUSE Keys included Schluessel inbegriffen				
							CHUB19_SP3	CHUB32	CHESL05	CHESL08	CHTAER16ZC
NKM0800316	ERA16	1:2	12000	8Nm		X	CHUB19_SP3	CHUB32	CHESL05	CHESL08	CHTAER16ZC
NKM0800416	ERA16	1:2	12000	8Nm	P=70bar	X	CHUB19_SP3	CHUB32	CHESL05	CHESL08	CHTAER16ZC

NAKAMURA-TOME
 WT300 - SC300 - SC30011 - TMC200/300M - SUPER NTX - SUPER NTXL - TW20M/MY/MM/MMY/MYY 12 ST.
 TW30M/MY/MM/MMY/MYY 16 ST.

MODULO MOTORIZZATO ORIENTABILE +/-90° MOLTIPLICATO I=1:2
 +/-90° adjustable angle driven tool geared-up I=1:2
 Angetriebenes Werkzeug schwenkbar +/-90° uebersetzt I=1:2

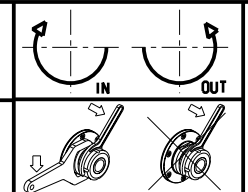

M.T. srl
 Via Casino Albini 480
 Tel. 0541/956034-957884
 Fax 0541/956341
 47842 S. GIOVANNI IN M. (RN)
 e-mail: mtma@mtmarchetti.com
 http://www.mtmarchetti.com

PRODUZIONE MODULI ROTANTI



PAGINA NKM336-3-00

Subject to change without notice.

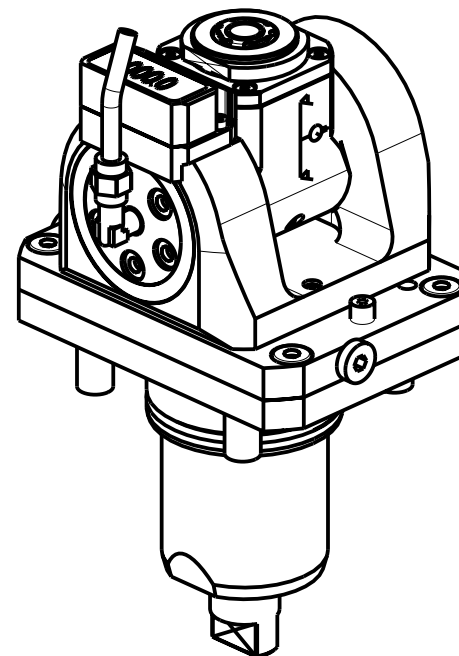
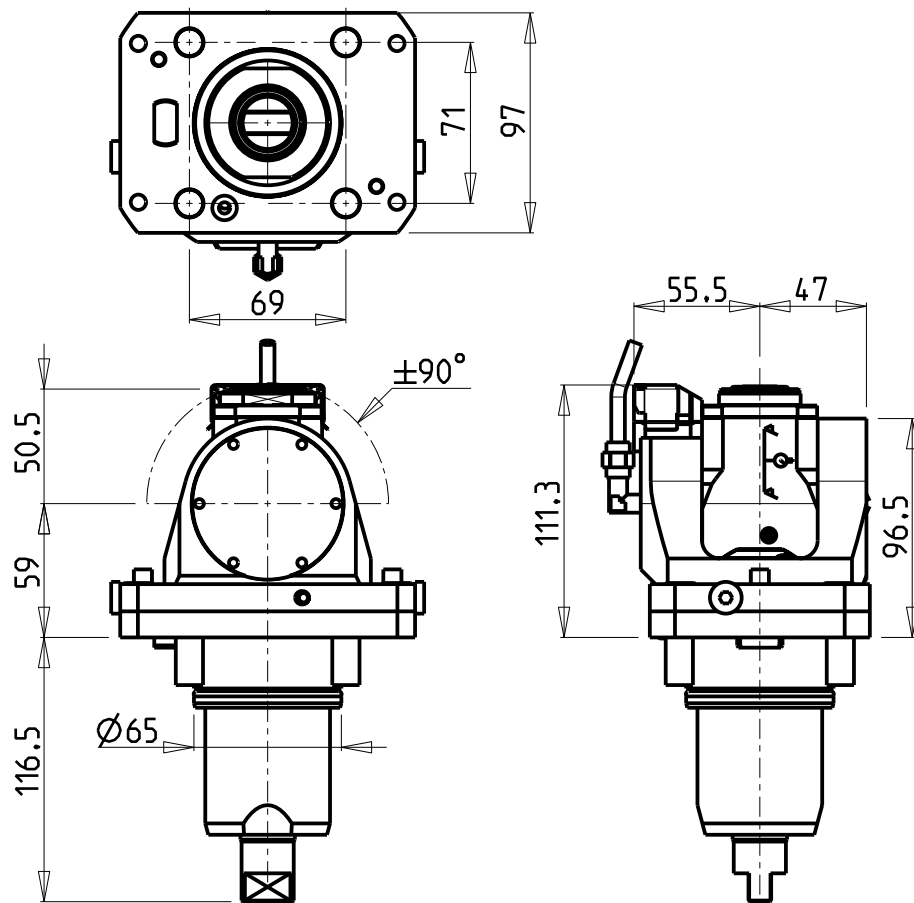

ATTENZIONE - ATTENTION - ACHTUNG

- Per lo smontaggio degli utensili utilizzare sempre la chiave di contrasto come indicato nel manuale d'uso.
- For disassembly of the tools use always the contrast key as mentioned in the user instructions.
- Fuer das Abmontieren der Werkzeuge immer den Gegenschlüssel benutzen wie in der Bedienungsanleitung erwaeht.

ATTENZIONE - ATTENTION - ACHTUNG

- Verificare la tabella sottostante per possibile interferenza su alcuni modelli di macchine
- Please check the table below for possible interferences on some machine models
- Die untenstehende tabelle unbedingt auf eventuelle interferenzen auf eingen maschinen modellen ueberpruefen

Cod. MT	Mandrino Spindle Spindel	I	RPM	Coppia Max Max Torque Max Drehmoment	Lubr.interna Coolant through Innenkuehlung	Lubrificazione est. Ext. coolant Aussenkuehlung	CHIAVI INCLUSE Keys included Schluessel inbegriffen				
							CHUB19_SP3	CHUB32	CHESL05	CHESL08	CHTAER16ZC
NKM0805316	ERA16	1:2	12000	8Nm	-	X	CHUB19_SP3	CHUB32	CHESL05	CHESL08	CHTAER16ZC
NKM0805416	ERA16	1:2	12000	8Nm	P=70bar	X	CHUB19_SP3	CHUB32	CHESL05	CHESL08	CHTAER16ZC

NAKAMURA-TOME

WT300 - SC300 - SC30011 - TMC200/300M - SUPER NTX - SUPER NTXL - TW20M/MY/MM/MMY/MYY 12 ST.
TW30M/MY/MM/MMY/MYY 16 ST.

MODULO MOTORIZZATO ORIENTABILE +/-90° MOLTIPLICATO I=1:2 CON NONIO DIGITALE

+/-90° adjustable angle driven tool geared-up I=1:2 with digital display

Angetriebenes Werkzeug schwenkbar +/-90° uebersetzt I=1:2 mit digital display

Subject to change without notice.

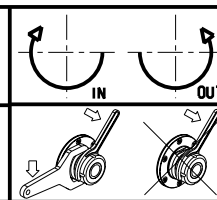

M.T. srl

Via Casino Albini 480
Tel. 0541/956034-957884
Fax 0541/956341
47842 S. GIOVANNI IN M. (RN)
e-mail: mtma@mtmarchetti.com
http://www.mtmarchetti.com

PRODUZIONE MODULI ROTANTI



PAGINA NKM336-3-01

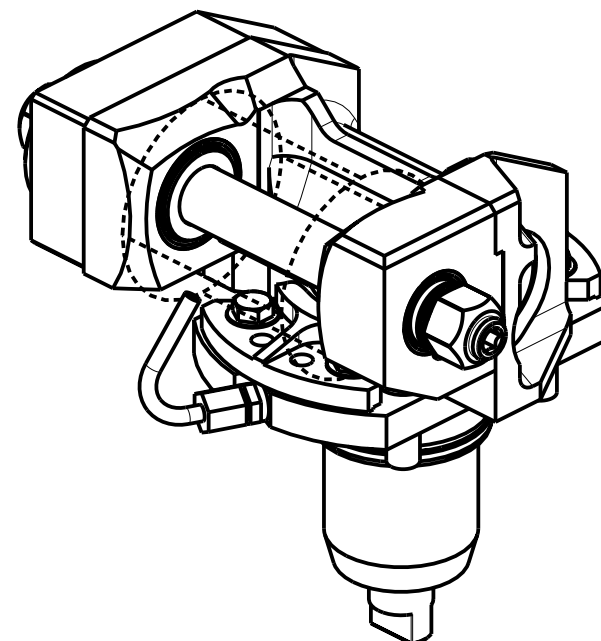
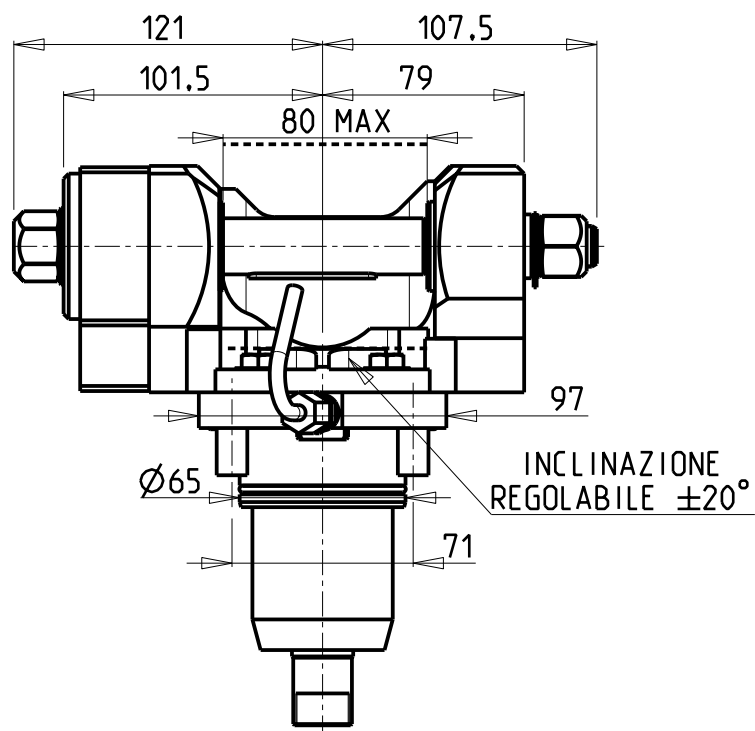
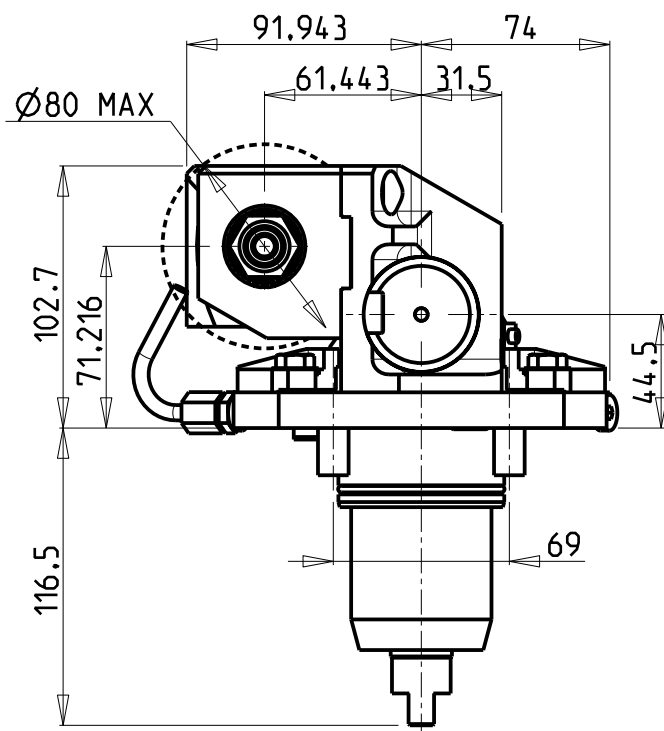

DOTAZIONI - SUPPLIED WITH - AUSSTATTUNG

- | | |
|------------------|---|
| mm / inch | - N°1 ALBERO + DISTANZIALI
- N°1 SHAFT + SPACER
- N°1 DORN + ABSTANDSSTUECK |
|------------------|---|

PER ALBERI E DISTANZIALI VEDI PAG. TBL250-1-00
FOR SHAFT END SPACER SEE PAGE TBL250-1-00
FUER DORN UND ABSTANDSSTUECK SEITE TBL250-1-00

Cod. MT	I	RPM max	Coppia Max Max Torque Max Drehmoment	Reversibile lato mandrino/contromandrino Reversible sub/main spindle side Umkehrbare Spindel-seite/ Gegenspindel-seite	Lubrificazione est. Ext. coolant Aussenkuehlung	D (mm)	D (Inch)	CHIAVI INCLUSE Keys included Schlüssel inbegriffen		
								CHUB13	CHUB24	CHESL08
NKM0311100	1:1	6000	60Nm	X	X	16-22-27-32	3/4"-1"-1 1/4"	CHUB13	CHUB24	CHESL08
NKM0312100	2:1	3000	80Nm	X	X	16-22-27-32	3/4"-1"-1 1/4"	CHUB13	CHUB24	CHESL08

NAKAMURA-TOME

WT300 - SC300 - SC30011 - TMC200/300M - SUPER NTX - SUPER NTXL - TW20M/MY/MM/MMY/MYY 12 ST.
TW30M/MY/MM/MMY/MYY 16 ST.

MODULO MOTORIZZATO PORTACREATORE

Driven gear hobber

Angetriebenes Zahnradwaeltzraes-Werkzeug

Subject to change without notice.

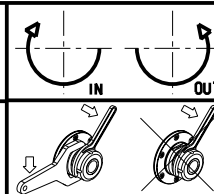

M.T. srl

Via Casino Albini 480
Tel. 0541/956034-957884
Fax 0541/956341
47842 S. GIOVANNI IN M. (RN)
e-mail: mtma@mtmarchetti.com
http://www.mtmarchetti.com

PRODUZIONE MODULI ROTANTI



PAGINA NKM340-3-00

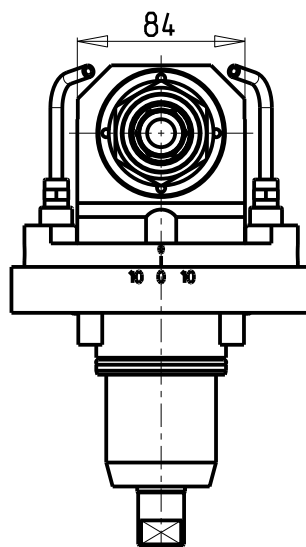
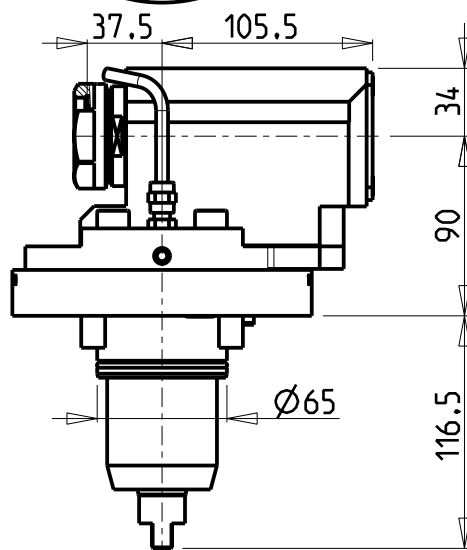
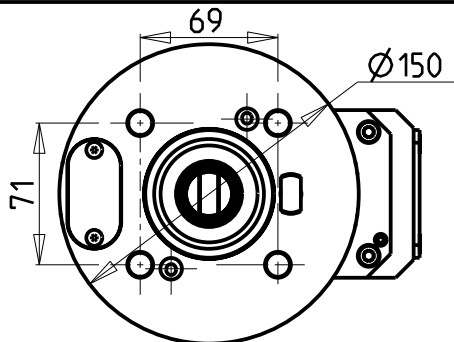

ATTENZIONE - ATTENTION - ACHTUNG

- VERIFICARE LE MISURE DI INGOMBRO PER POSSIBILE INTERFERENZA SU ALCUNI MODELLI DI MACCHINE
- Please check the overall sizes for possible interferences on some machine models
- Bitte überprüfen sie das ausmass um mögliche interferenzen auf einigen maschinen modellen zu vermeiden

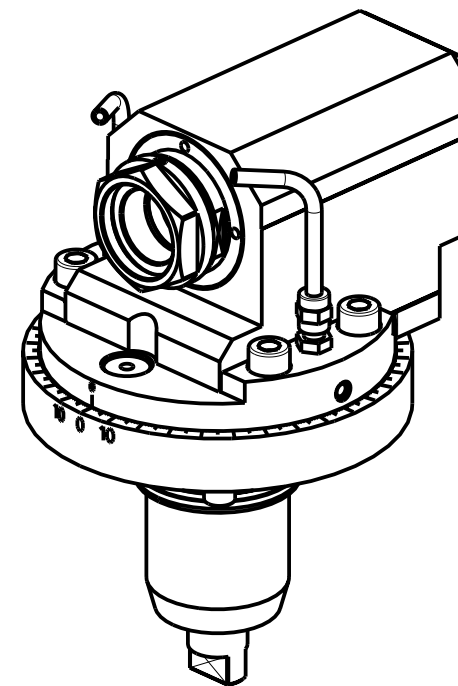

PER PORTAUTENSILI MODULARI MTSK-40 VEDI PAG. TBL300-1-40
 FOR MTSK-40 QUIK CHANGE TOOLHOLDERS CLAMPINGS SEE PAGE TBL300-1-40
 FUER MTSK-40 MODULARE WERKZEUGAUFNAHMEN SIEHE SEITE TBL300-1-40

Cod. MT	Mandrino Spindle Spindel	I	RPM	Coppia Max Max Torque Max Drehmoment	Reversibile lato mandrino/contromandrino Reversible sub/main spindle side Umkehrbare Spindel-seite/ Gegenspindel-seite	Lubr.esterna Ext. coolant Aussenkuehlung	CHIAVI INCLUSE Keys included Schluessel einbegriffen
NKM1180100	MTSK-40	1:1	6000	50Nm	X	X	n°2 CHUB46

NAKAMURA-TOME

WT300 - SC300 - SC300II - TW20MY/MMY/MYY 12 ST. - TW30MY/MMY/MYY 16 ST.

MODULO MOTORIZZATO ASSIALE MTSK PER POWER SKIVING H=90mm

Axial MTSK driven tool for Power Skiving H=90mm

Axial MTSK angetriebenes Werkzeug fuer Power Skiving H=90mm

Subject to change without notice.

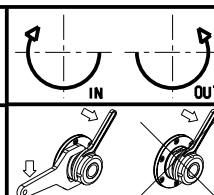

M.T. srl

Via Casino Albini 480
 Tel. 0541/956034-957884
 Fax 0541/956341
 47842 S. GIOVANNI IN M. (RN)
 e-mail: mtma@mtmarchetti.com
 http://www.mtmarchetti.com

PRODUZIONE MODULI ROTANTI



PAGINA NKM350-3-00-K

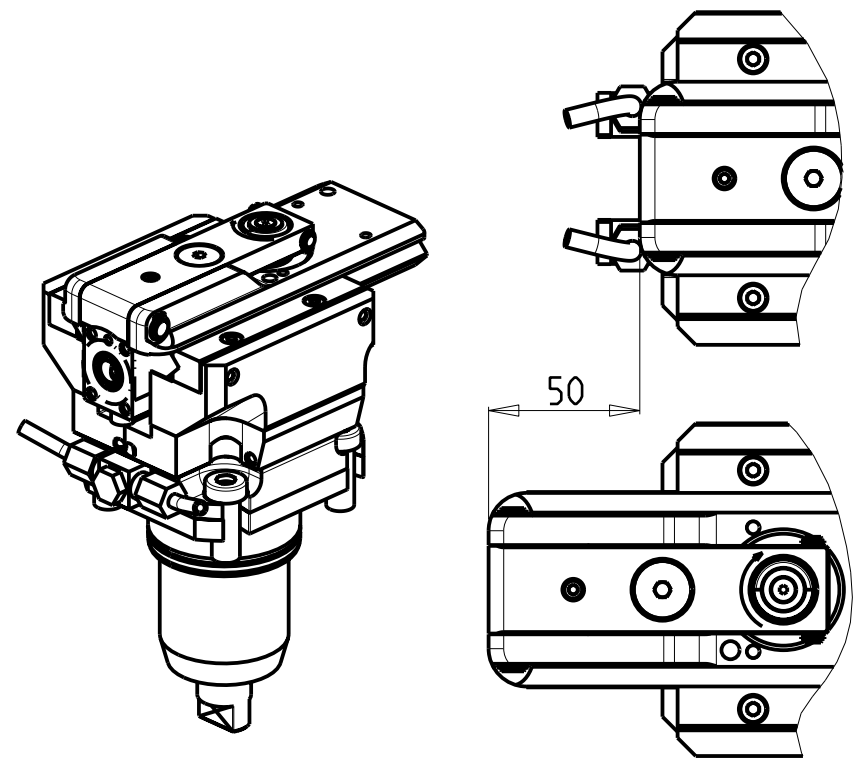
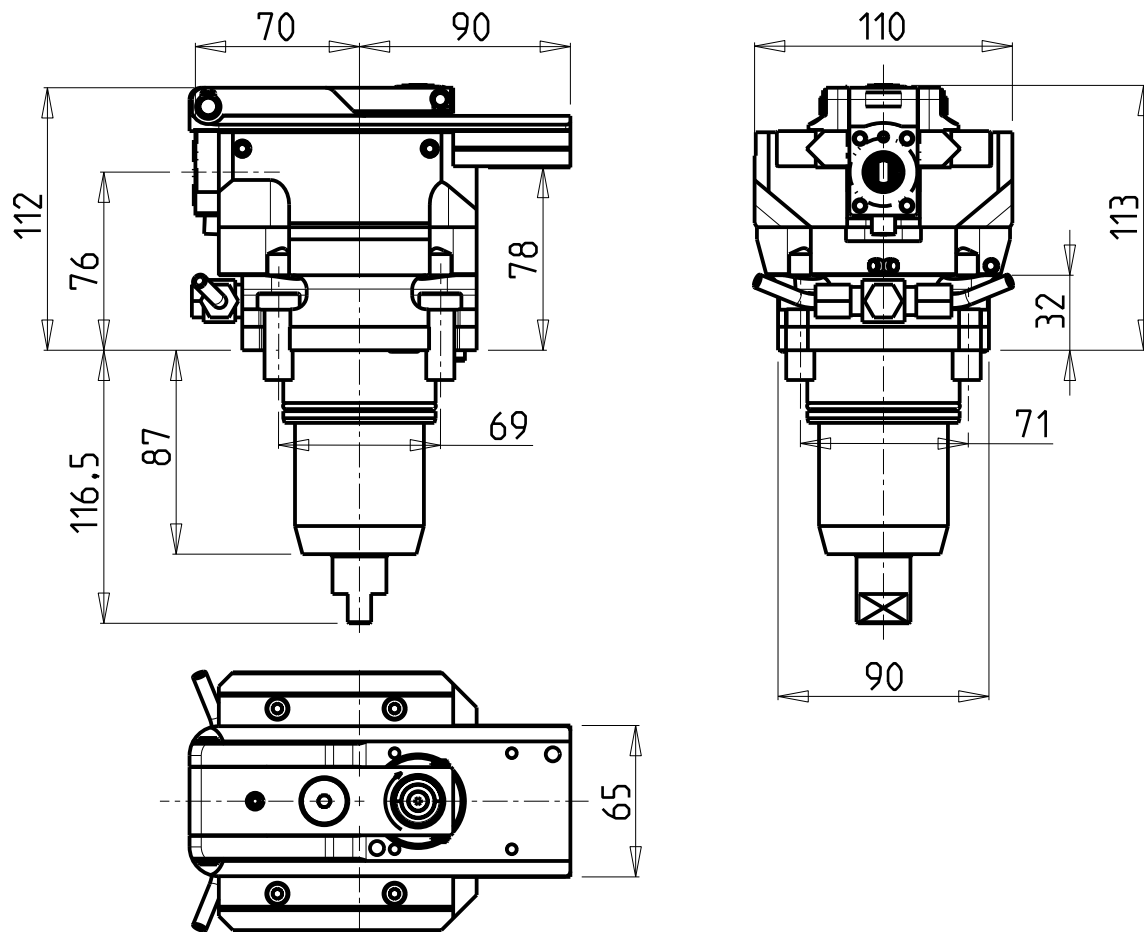

PER UTENSILI STOZZATORI VEDI PAG. TBL400-1-00
 FOR DRIVEN SLOTTING TOOL CUTTING-TOOLS SEE PAGE TBL400-1-00
 FÜR NUTENSTOSS-WERKZEUG SCHNEIDWERKZEUGE SIEHE SEITE TBL400-1-00

Cod. MT	I	RPM MAX	Reversibile lato mandrino/contromandrino Reversible sub/main spindle side Umkehrbare Spindel-seite/ Gegenspindel-seite	Lubr. esterna Ext. coolant Aussenkuehlung
NKM0930100	4:1	2000	X	X

NAKAMURA - TOME

WT300 - SC300 - SC30011 - TMC200/300M - SUPER NTX - SUPER NTXL - TW20M/MY/MM/MMY/MYY 12 ST.
 TW30M/MY/MM/MMY/MYY 16 ST.

MODULO MOTORIZZATO STOZZATORE CORSA 50mm

Slotting driven tool 50mm stroke

Keilnutenstossmaschine 50mm Hub

Subject to change without notice.

M.T. srl

Via Casino Albini 480
 Tel. 0541/956034-957884
 Fax 0541/956341
 47842 S. GIOVANNI IN M. (RN)
 e-mail: mtma@mtmarchetti.com
 http://www.mtmarchetti.com

PRODUZIONE MODULI ROTANTI



PAGINA NKM360-3-00

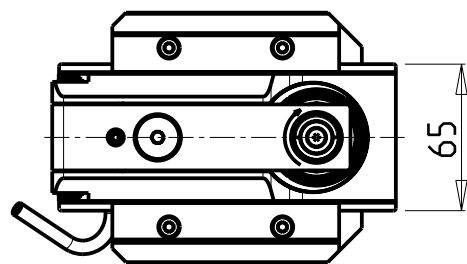
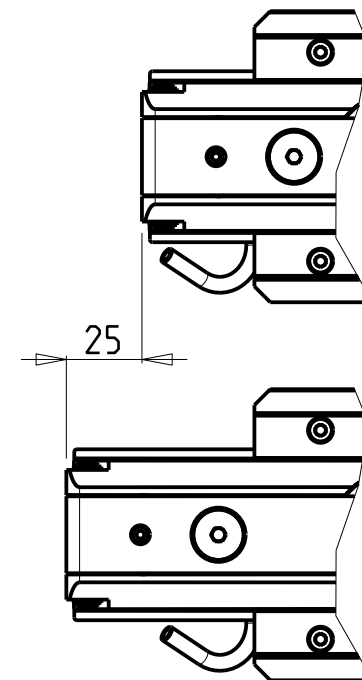
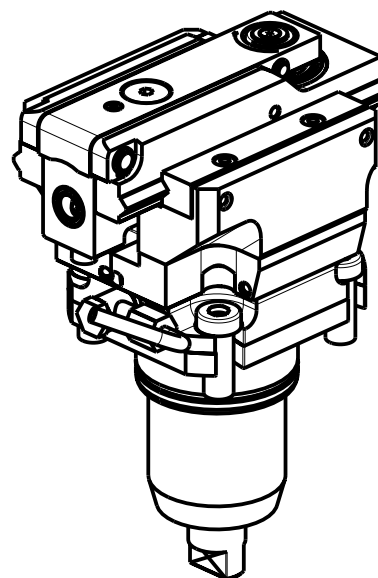
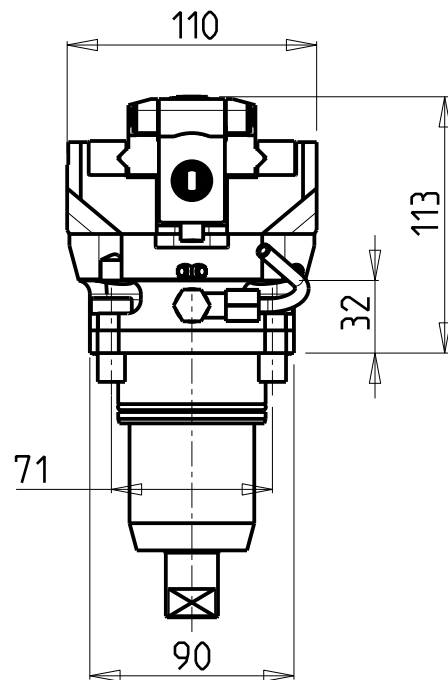
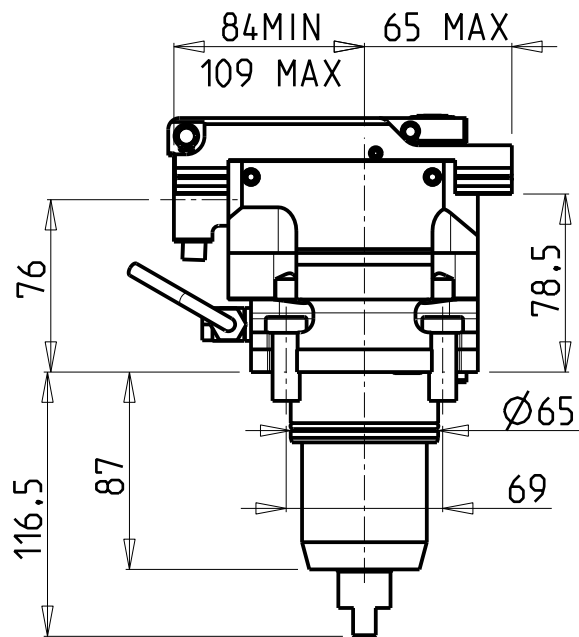

PER UTENSILI STOZZATORI VEDI PAG. TBL400-1-00
 FOR DRIVEN SLOTTING TOOL CUTTING-TOOLS SEE PAGE TBL400-1-00
 FÜR NUTENSTOSS-WERKZEUG SCHNEIDWERKZEUGE SIEHE SEITE TBL400-1-00

Cod. MT	I	RPM MAX	Reversibile lato mandrino/contromandrino Reversible sub/main spindle side Umkehrbare Spindel-seite/ Gegenspindel-seite	Lubr. esterna Ext. coolant Aussenkuehlung
NKM0930200	4:1	2400	X	X

NAKAMURA - TOME

WT300 - SC300 - SC30011 - TMC200/300M - SUPER NTX - SUPER NTXL - TW20M/MY/MM/MMY/MMYY 12 ST.
 TW30M/MY/MM/MMY/MMYY 16 ST.

MODULO MOTORIZZATO STOZZATORE CORSA 25mm

Slotting driven tool 25mm stroke

Keilnutenstossmaschine 25mm Hub

Subject to change without notice.

M.T. srl

Via Casino Albini 480
 Tel. 0541/956034-957884
 Fax 0541/956341
 47842 S. GIOVANNI IN M. (RN)
 e-mail: mtma@mtmarchetti.com
 http://www.mtmarchetti.com

PRODUZIONE MODULI ROTANTI



PAGINA NKM360-3-01

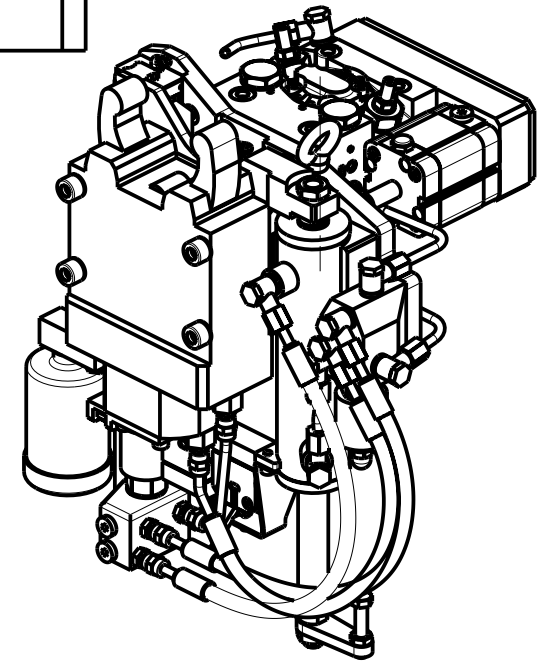
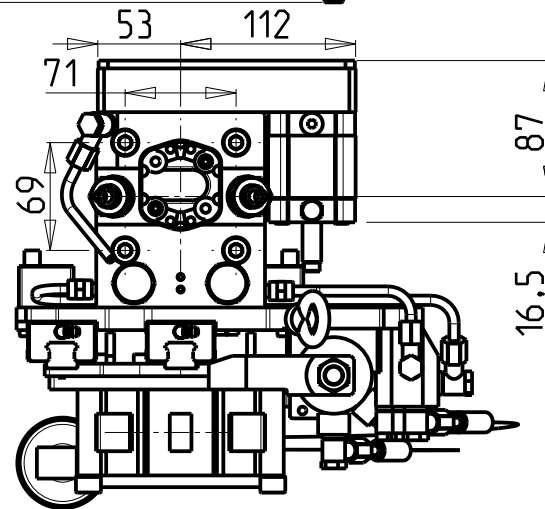
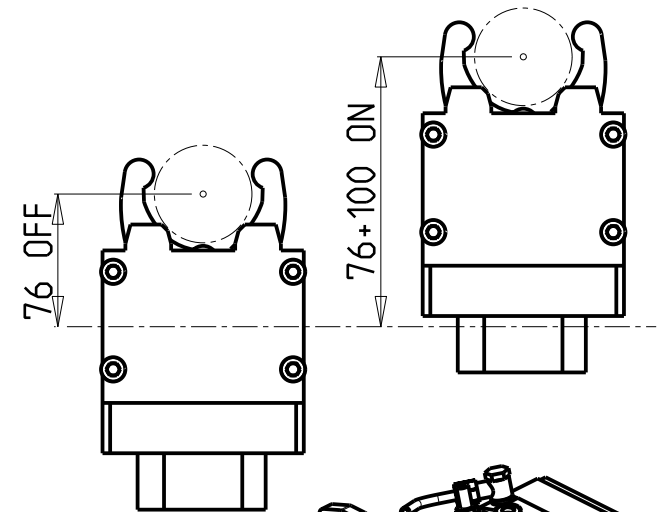
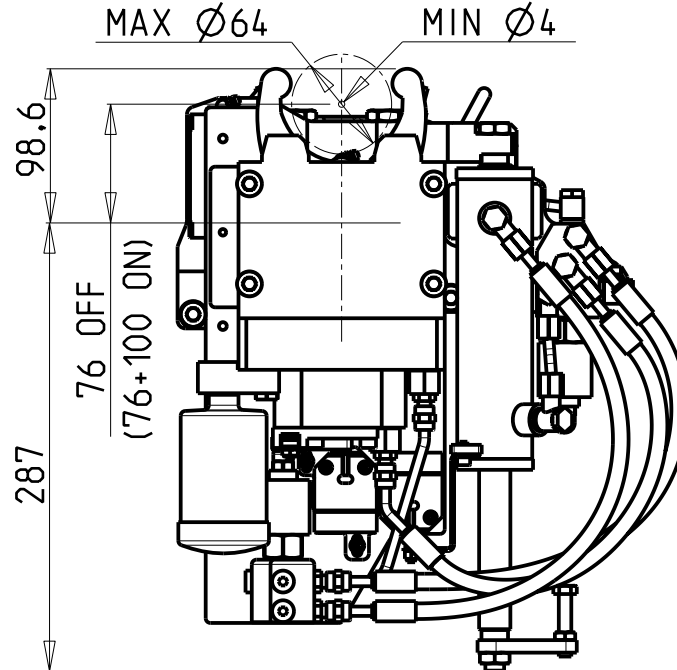
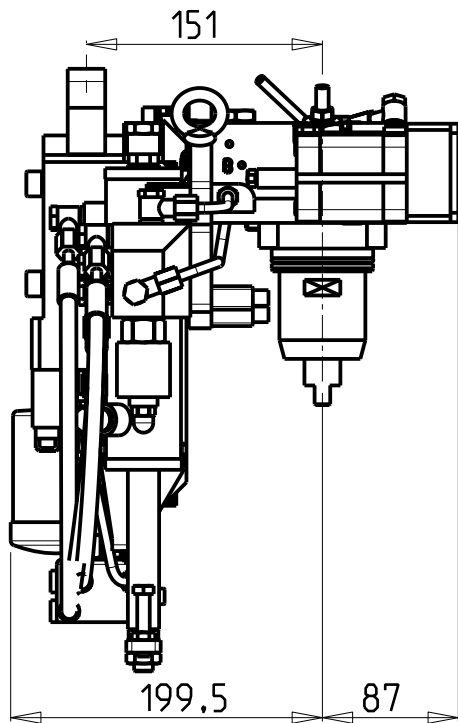

(())	#	CON GESTIONE ELETTRONICA APERTURA COMPLETA DELLA LUNETTA
	#	With Electronic control of steady rest arms complete opening
	#	Mit vollstaendiger elektronischer Oeffnungsbedienung der Luenette

	Cod. MT	I	RPM	Lubr.esterna Ext. coolant Aussenkuehlung
#	NKM0950300	1:1	6000	X
#	NKM0950300EU	1:1	6000	X
#	NKM0950300US	1:1	6000	X

PER U.S.A.-AUSTRALIA-CANADA
For U.S.A.-Australia-Canada
Fuer U.S.A.-Australien-Kanada

NAKAMURA-TOME
WT300 - SUPER NTX

MODULO MOTORIZZATO PER LUNETTA RETRATTILE (TAGLIA 1)
Driven toolholder for sliding steady rest (Size 1)
Luenettenwerkzeug zurueck versetzte Version (Grossse 1)

Subject to change without notice.

M.T. srl

Via Casino Albini 480
Tel. 0541/956034-957884
Fax 0541/956341
47842 S. GIOVANNI IN M. (RN)
e-mail: mtma@mtmarchetti.com
http://www.mtmarchetti.com

PRODUZIONE MODULI ROTANTI



PAGINA NKM363-3-00

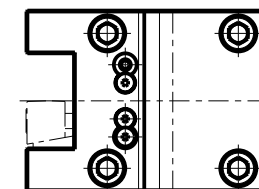
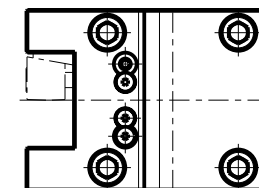
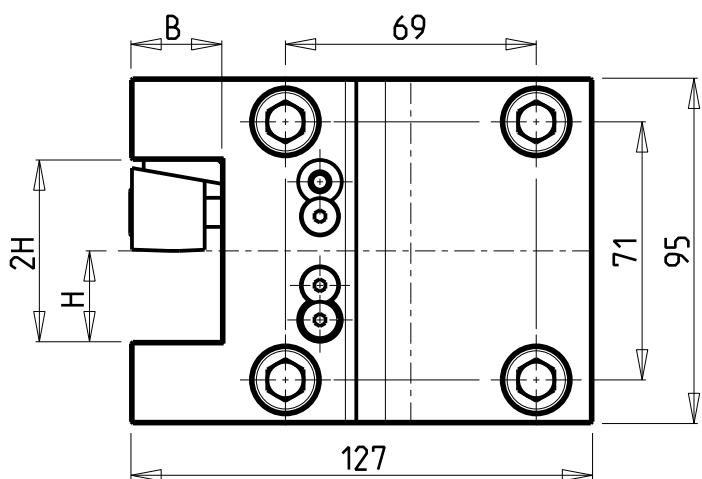
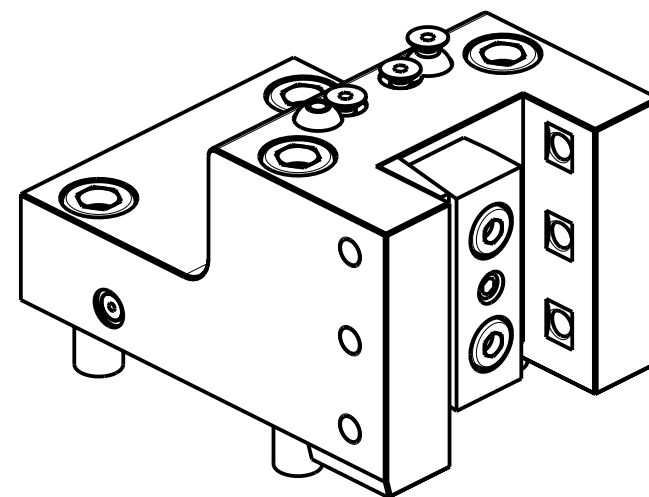
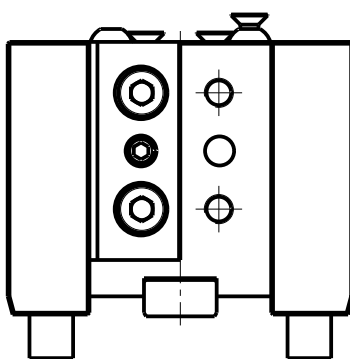
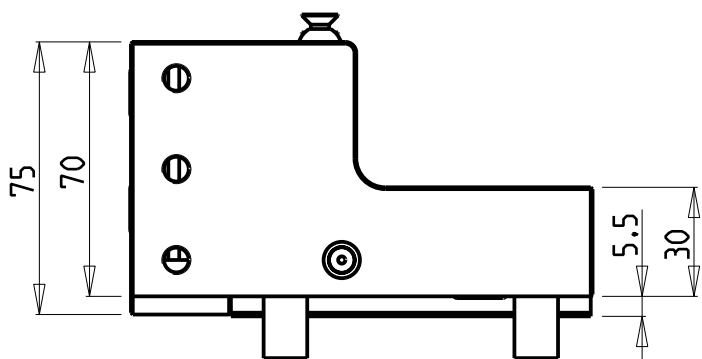

Cod. MT	N°Utensili N° Tools N° Werkzeuge	Reversibile lato mandrino/contromandrino Reversible sub/main spindle side Umkehrbare Spindel-seite/ Gegenspindel-seite	B	H
NKM0512500	1/2	X	25	25

NAKAMURA - TOME

WT300 - SC300 - SC30011 - TMC200/300M - SUPER NTX - SUPER NTXL - TW20M/MY/MM/MMY/MYY 12 ST.
TW30M/MY/MM/MMY/MYY 16 ST.

PORTAUTENSILE RADIALE SINGOLO QD=25mm

Radial single static tool QD=25mm

Radial Single-Werkzeughalter QD=25mm

Subject to change without notice.

M.T. srl

Via Casino Albini 480
Tel. 0541/956034-957884
Fax 0541/956341

47842 S. GIOVANNI IN M. (RN)
e-mail: mtma@mtmarchetti.com
http://www.mtmarchetti.com

PRODUZIONE MODULI ROTANTI



PAGINA NKM423-3-00

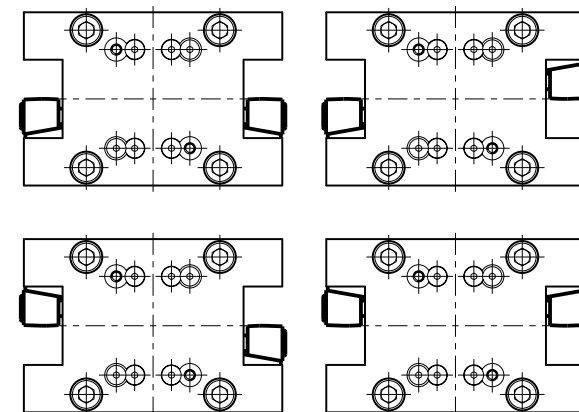
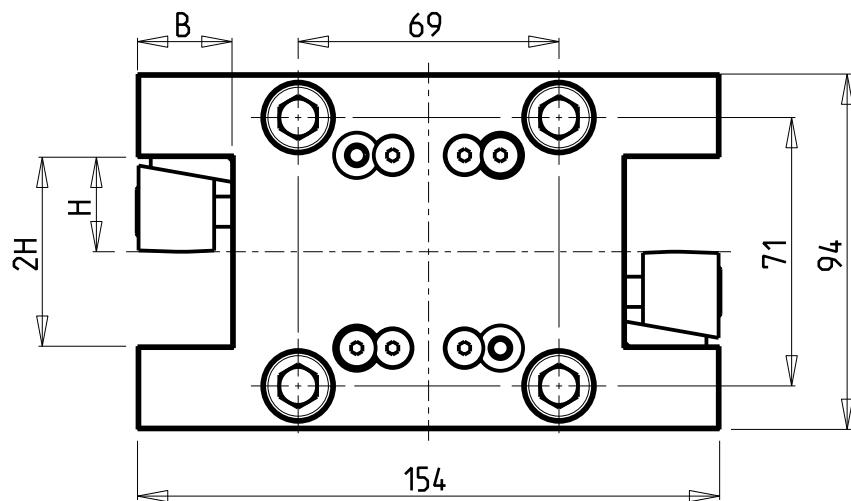
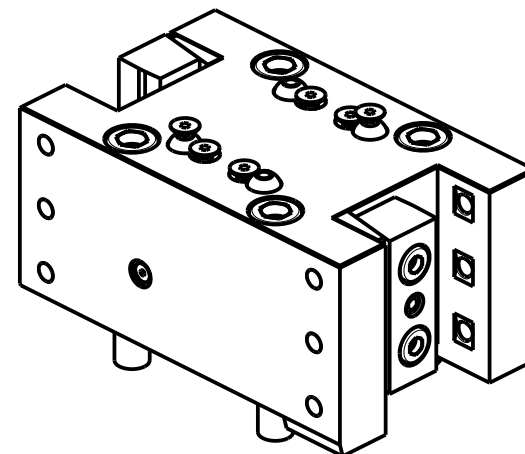
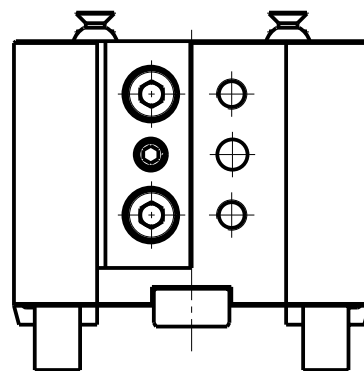
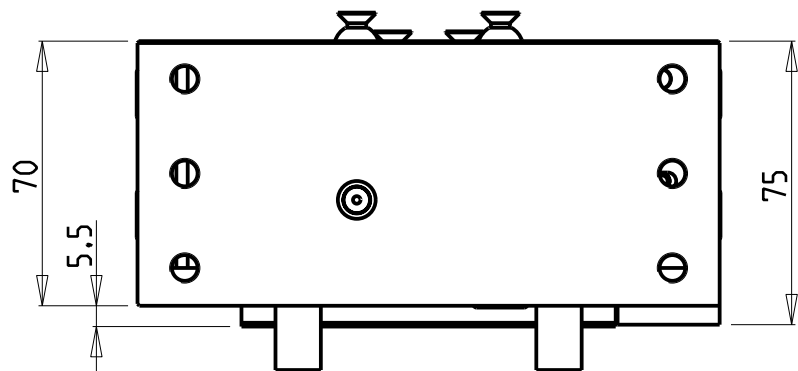

Cod. MT	N°Utensili N°Tools N°Werkzeuge	Reversibile lato mandrino/contromandrino Reversible sub/main spindle side Umkehrbare Spindel-seite/ Gegenspindel-seite	B	H
NKM0532500	2	X	25	25

NAKAMURA - TOME
 WT300 - SC300 - SC30011 - TMC200/300M - SUPER NTX - SUPER NTXL - TW20M/MY/MM/MMY/MMYY 12 ST.
 TW30M/MY/MM/MMY/MMYY 16 ST.

PORTAUTENSILE RADIALE DOPPIO QD=25mm
 Radial double static tool QD=25mm
 Radial Doppel-Werkzeughalter QD=25mm

Subject to change without notice.

M.T. srl
 Via Casino Albini 480
 Tel. 0541/956034-957884
 Fax 0541/956341
 47842 S. GIOVANNI IN M. (RN)
 e-mail: mtma@mtmarchetti.com
 http://www.mtmarchetti.com

PRODUZIONE MODULI ROTANTI



PAGINA NKM453-3-00

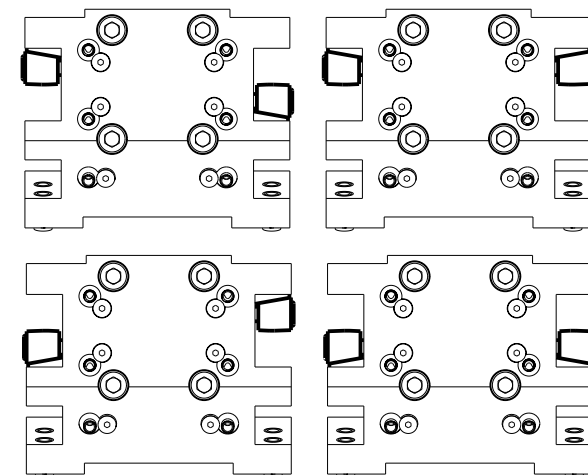
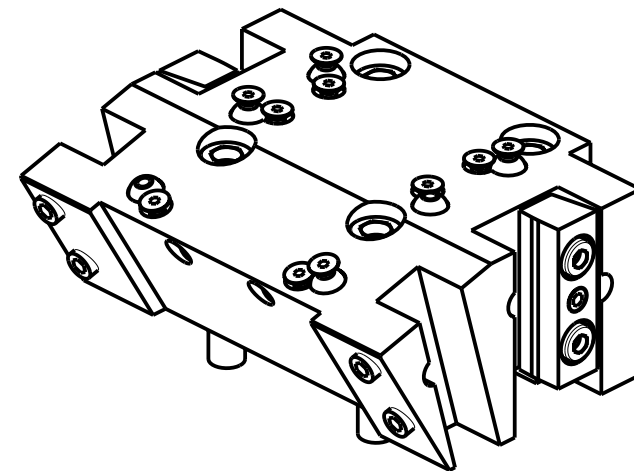
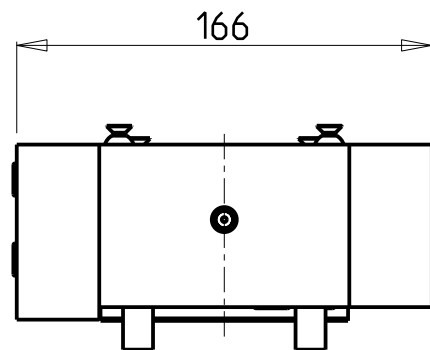
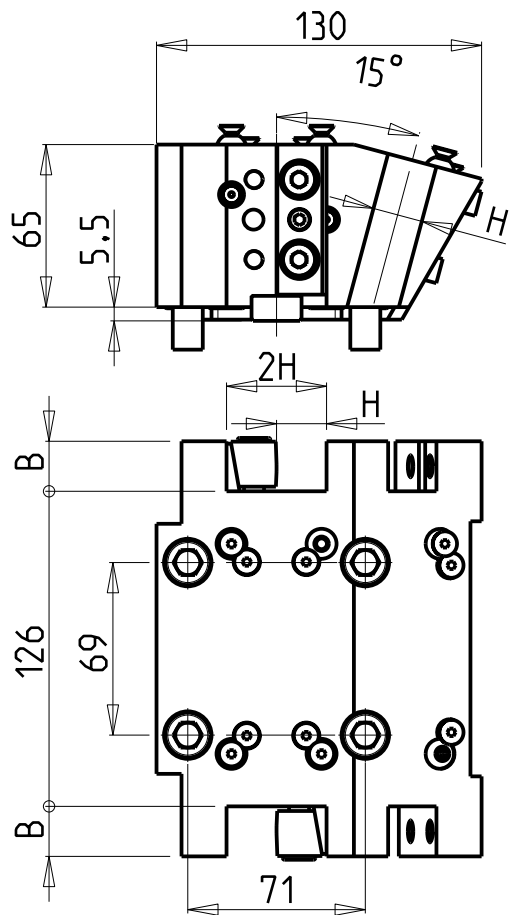

Cod. MT	N°Utensili N°Tools N°Werkzeuge	Reversibile lato mandrino/contromandrino Reversible sub/main spindle side Umkehrbare Spindel-seite/ Gegenspindel-seite	Misure Dimensions Masse	B	H
NKM0572000	4	X	mm	20	20
NKM0571905	4	X	Inch	3/4"	3/4"

NAKAMURA-TOME

WT300 - SC300 - TW20M/MY/MM/MMY/MYY 12 ST.

PORTAUTENSILE RADIALE MULTIPLIO QD=20mm / QD=3/4"

Radial multiple static tool QD=20mm / QD=3/4"

Radial Mehrfach-Halter QD=20mm / QD=3/4"

Subject to change without notice.

M.T. srl

Via Casino Albini 480
Tel. 0541/956034-957884
Fax 0541/956341
47842 S. GIOVANNI IN M. (RN)
e-mail: mtma@mtmarchetti.com
http://www.mtmarchetti.com

PRODUZIONE MODULI ROTANTI



PAGINA NKM470-3-00

10/2018

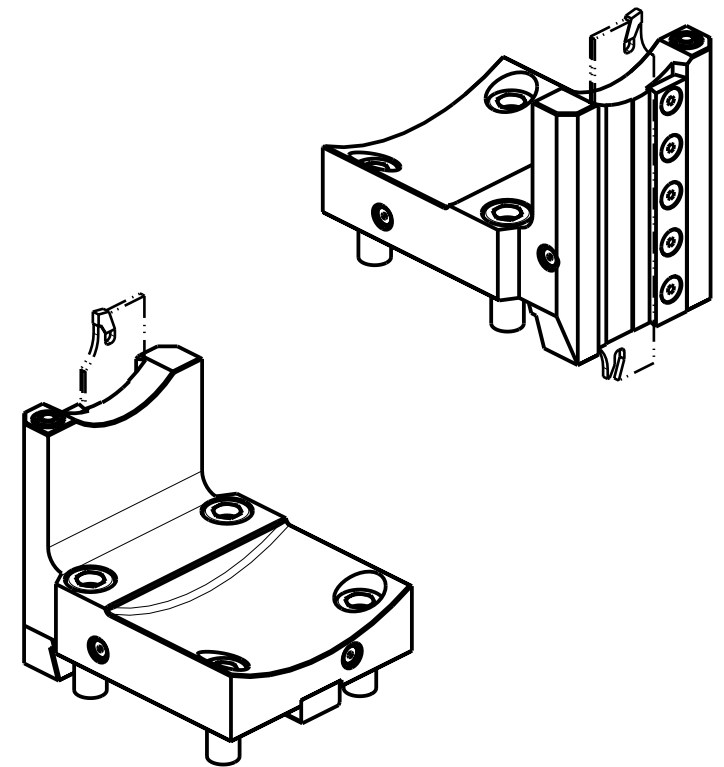
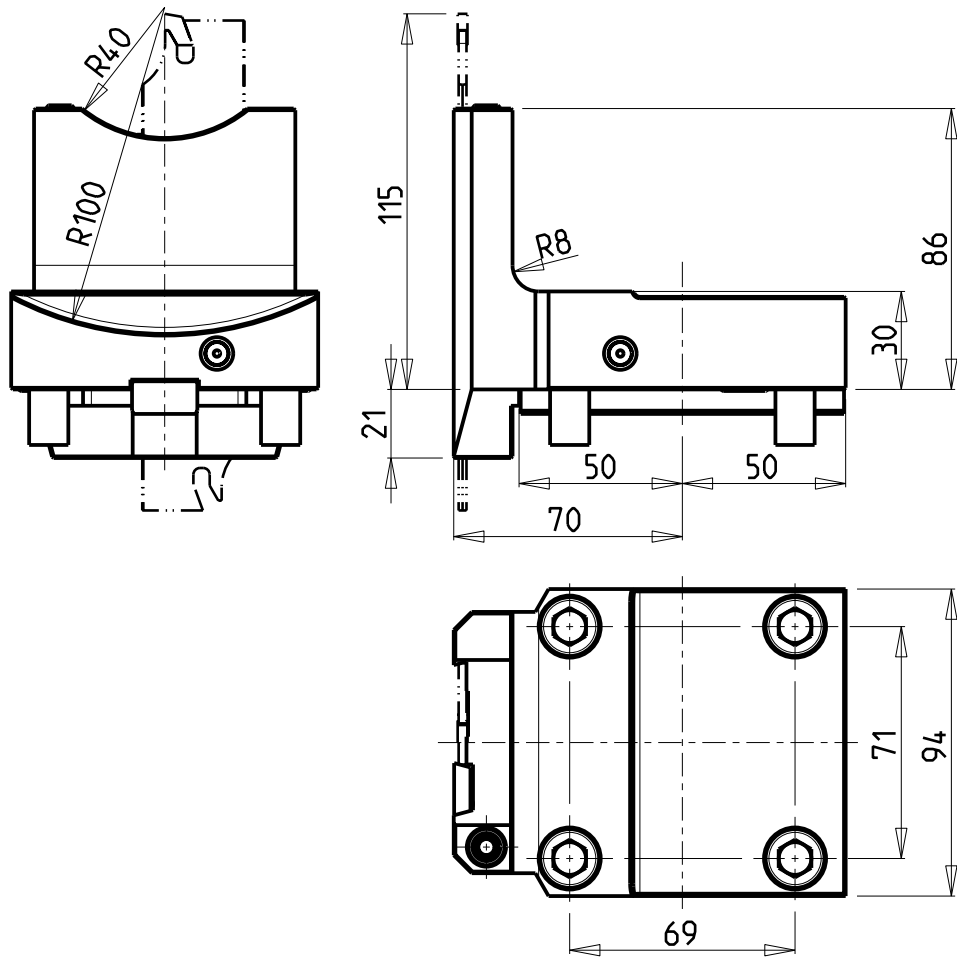

DOTAZIONI - SUPPLIED WITH - AUSSTATTUNG

- N°1 - LAMA - BLADE - KLINGE ISCAR H=32 Sp. 3/4mm (KENNAMETAL OPTIONAL)
- N°10 - INSERTI - INSERTS - EINLAGEN
- N°1 - CHIAVE A T PER MONTAGGIO INSERTI
- T-WRENCH FOR INSERT SET UP
- T-SCHLUESSEL FUER EINSATZSTUECK-MONTAGE

Cod. MT	N°Utensili N° Tools N°Werkzeuge	Reversibile lato mandrino/contromandrino Reversible sub/main spindle side Umkehrbare Spindel-seite/ Gegenspindel-seite
NKM0580132	1	X

NAKAMURA-TOME
 WT300 - SC300 - SC30011 - TMC200/300M - SUPER NTX - SUPER NTXL - TW20M/MY/MM/MYY/MYY 12 ST.
 TW30M/MY/MM/MYY/MYY 16 ST.

PORTAUTENSILE RADIALE PER LAMA
 Radial blade holder
 Radial Abstechhalter

M.T. srl
 Via Casino Albini 480
 Tel. 0541/956034-957884
 Fax 0541/956341
 47842 S. GIOVANNI IN M. (RN)
 e-mail: mtma@mtmarchetti.com
 http://www.mtmarchetti.com

PRODUZIONE MODULI ROTANTI



PAGINA NKM510-3-00

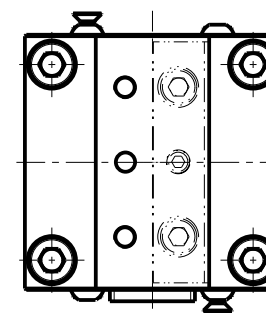
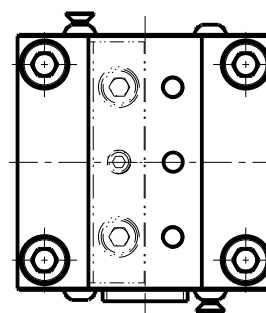
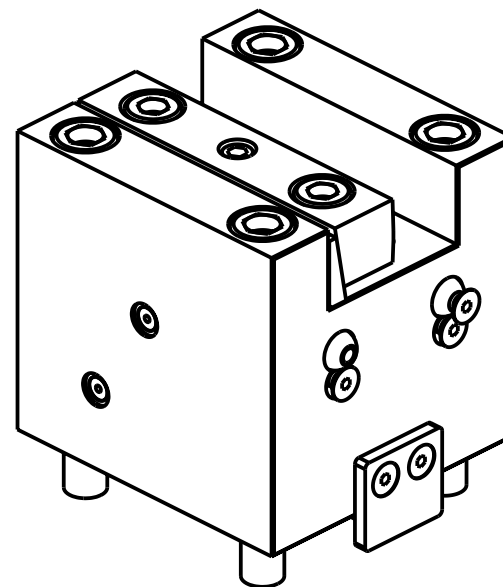
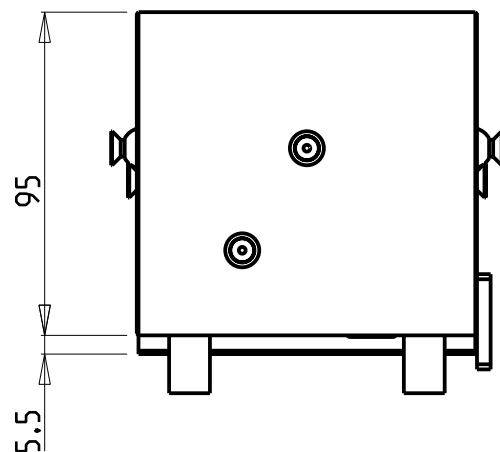
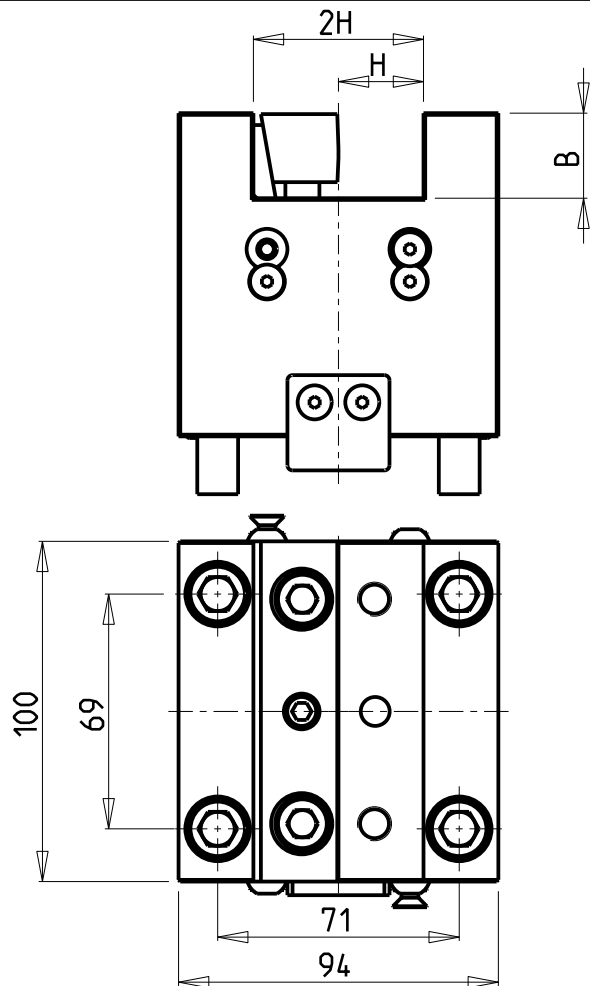

Cod. MT	N°Utensili N° Tools N°Werkzeuge	Reversibile lato mandrino/contromandrino Reversible sub/main spindle side Umkehrbare Spindelseite/ Gegenspindelseite	Misure Dimensions Masse	B	H
NKM0522500	1	X	mm	25	25

NAKAMURA - TOME

WT300 - SC300 - SC30011 - TMC200/300M - SUPER NTX - SUPER NTXL - TW20M/MY/MM/MMY/MMYY 12 ST.
TW30M/MY/MM/MMY/MMYY 16 ST.

PORTAUTENSILE ASSIALE SINGOLO QD=25mm

Axial single static tool QD=25mm

Axial Single-Werkzeughalter QD=25mm

Subject to change without notice.

M.T. srl

Via Casino Albini 480
Tel. 0541/956034-957884
Fax 0541/956341
47842 S. GIOVANNI IN M. (RN)
e-mail: mtma@mtmarchetti.com
http://www.mtmarchetti.com

PRODUZIONE MODULI ROTANTI



PAGINA NKM552-3-00

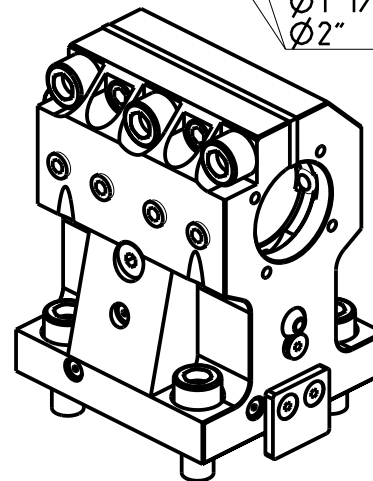
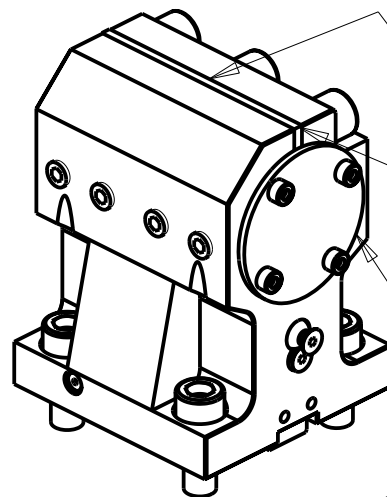
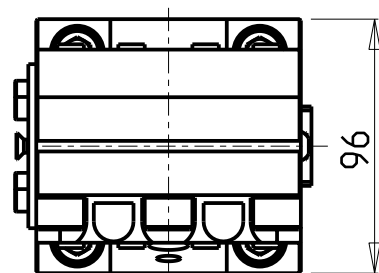
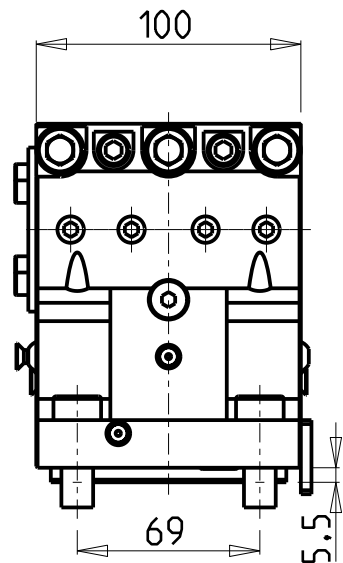
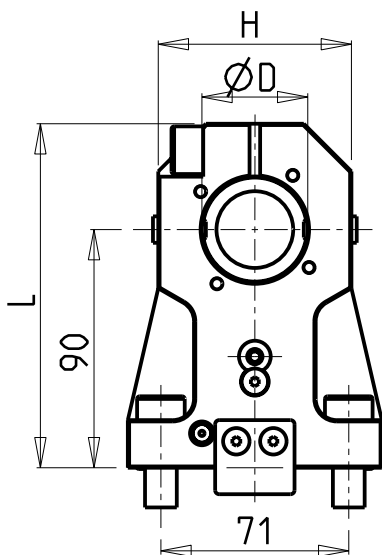

ATTENZIONE - ATTENTION - ACHTUNG

- Verificare la tabella sottostante per possibile interferenza su alcuni modelli di macchine
- Please check the table below for possible interferences on some machine models
- Die untenstehende Tabelle unbedingt auf eventuelle Interferenzen auf einigen Maschinenmodellen überprüfen

SOLO GUARNIZIONE (OPZIONALE)
 ONLY SEAL (OPTIONAL)
 NUR DICHTUNG (OPTIONAL)
 cod. NKM0470004

KIT ADDUZIONE INTERNA (OPZIONALE)
 KIT FOR INTERNAL COOLANT (OPTIONAL)
 KIT FUER INTERNE KUEHLMITTELZUFUHR (OPTIONAL)
 Ø40mm cod. KIT1007003
 Ø1 1/2" cod. KIT1007004
 Ø2" cod. KIT1007002

PER BOCCOLE DI RIDUZIONE VEDI PAG. TBL150-1-00
 FOR REDUCING BUSHINGS SEE PAGE TBL150-1-00
 FÜR REDUZIERBUCHSE SIEHE SEITE TBL150-1-00

Cod. MT	Reversibile lato mandrino/contromandrino Reversible sub/main spindle side Umkehrbare Spindel-seite/ Gegenspindel-seite	Lubrificazione est. Ext. coolant Aus-senkuehlung	Lubrificazione int. opzionale Coolant through optional Innenkuehlung Optional	D	L	H
NKM0474000	X	X	X	40	130	73
NKM0473810	X	X	X	1 1/2"	130	73
NKM0475080	X	X	X	2"	135	83

NAKAMURA-TOME

WT300 - SC300 - SC30011 - TMC200/300M - SUPER NTX - SUPER NTXL - TW20M/MY/MM/MMY/MMYY 12 ST.
 TW30M/MY/MM/MMY/MMYY 16 ST.

PORTAUTENSILE ASSIALE PER BARENO Ø40mm H=90mm

Axial single boring bar holder Ø40mm H=90mm

Axial Bohrhälter Ø40mm H=90mm.

Subject to change without notice.

M.T. srl

Via Casino Albini 480
 Tel. 0541/956034-957884
 Fax 0541/956341
 47842 S. GIOVANNI IN M. (RN)
 e-mail: mtma@mtmarchetti.com
 http://www.mtmarchetti.com

PRODUZIONE MODULI ROTANTI



PAGINA NKM610-3-20

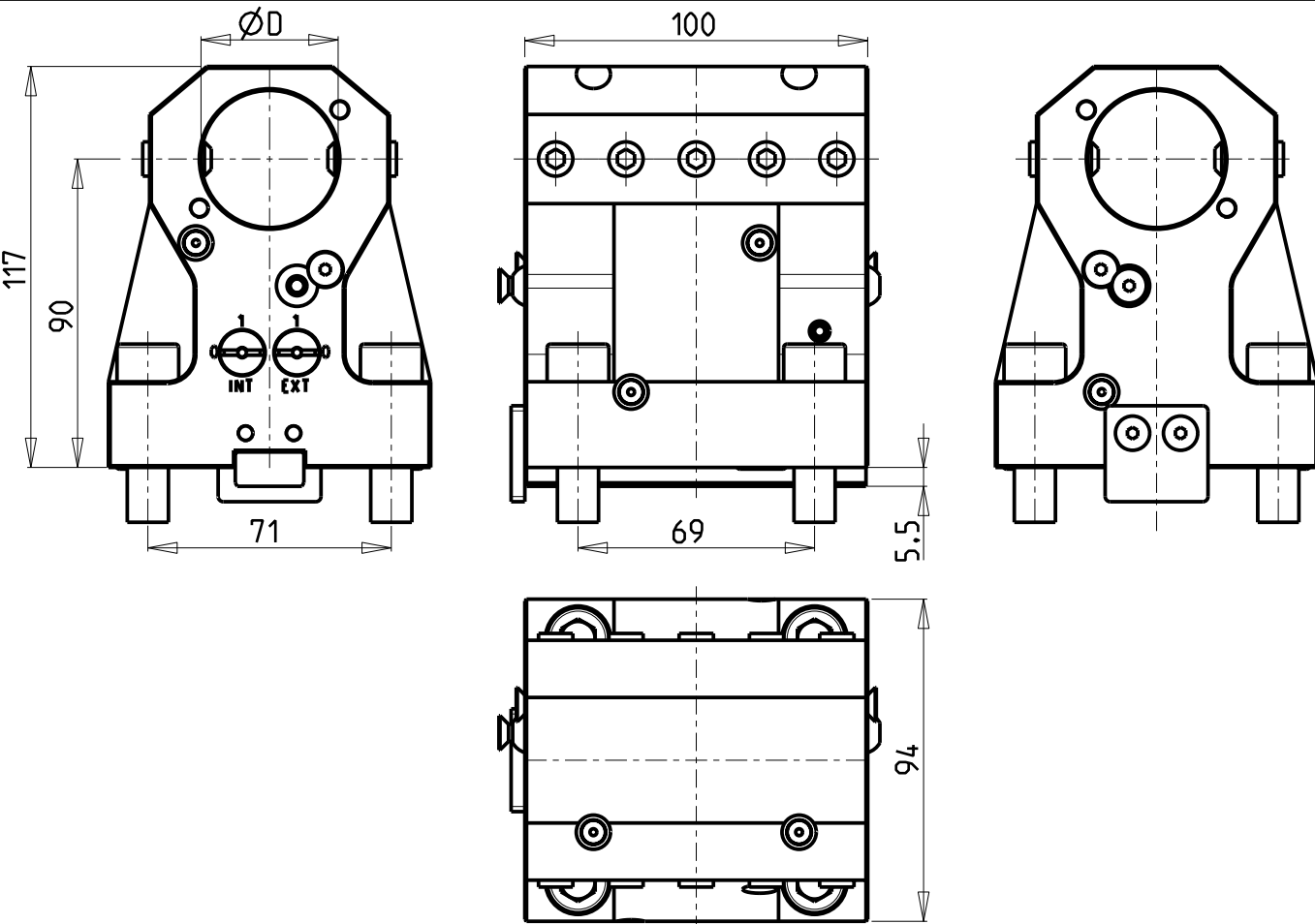

KIT ADDUZIONE INTERNA (OPZIONALE)
 KIT FOR INTERNAL COOLANT (OPTIONAL)
 KIT FUER INTERNE KUEHLMITTELZUFUHR (OPTIONAL)
 Ø40 cod. KIT1000018
 Ø32 cod. KIT1000001

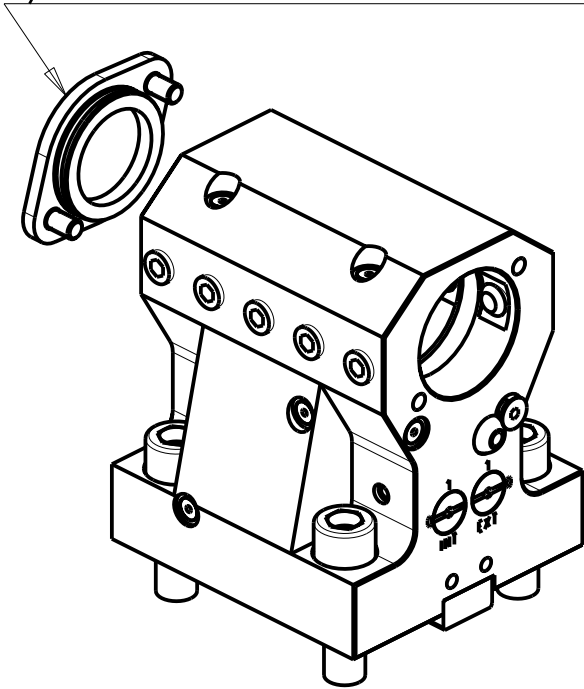

PER BOCCOLE DI RIDUZIONE VEDI PAG. TBL150-1-00
 FOR REDUCING BUSHINGS SEE PAGE TBL150-1-00
 FÜR REDUZIERBUCHSE SIEHE SEITE TBL150-1-00

Cod. MT	N°Utensili N°Tools N°Werkzeuge	Reversibile lato mandrino/contromandrino Reversible sub/main spindle side Umkehrbare Spindel-seite/ Gegenspindel-seite	Lubrificazione int. opzionale Coolant through optional Innenkuehlung Optional	Lubrificazione est. Ext. coolant Aussenkuehlung	D
NKM0544000	1	X	X	X	40
NKM0543200	1	X	X	X	32

NAKAMURA - TOME
 WT300 - SC300 - SC30011 - TMC200/300M - SUPER NTX - SUPER NTXL - TW20M/MY/MM/MMY/MMYY 12 ST.
 TW30M/MY/MM/MMY/MMYY 16 ST.

PORTAUTENSILE ASSIALE PER BARENO Ø40mm / Ø32mm H=90mm
 Axial single boring bar holder Ø40mm / Ø32mm H=90mm
 Axial Bohrhälter Ø40mm / Ø32mm H=90mm

Subject to change without notice.

M.T. srl
 Via Casino Albini 480
 Tel. 0541/956034-957884
 Fax 0541/956341
 47842 S. GIOVANNI IN M. (RN)
 e-mail: mtma@mtmarchetti.com
 http://www.mtmarchetti.com

PRODUZIONE MODULI ROTANTI

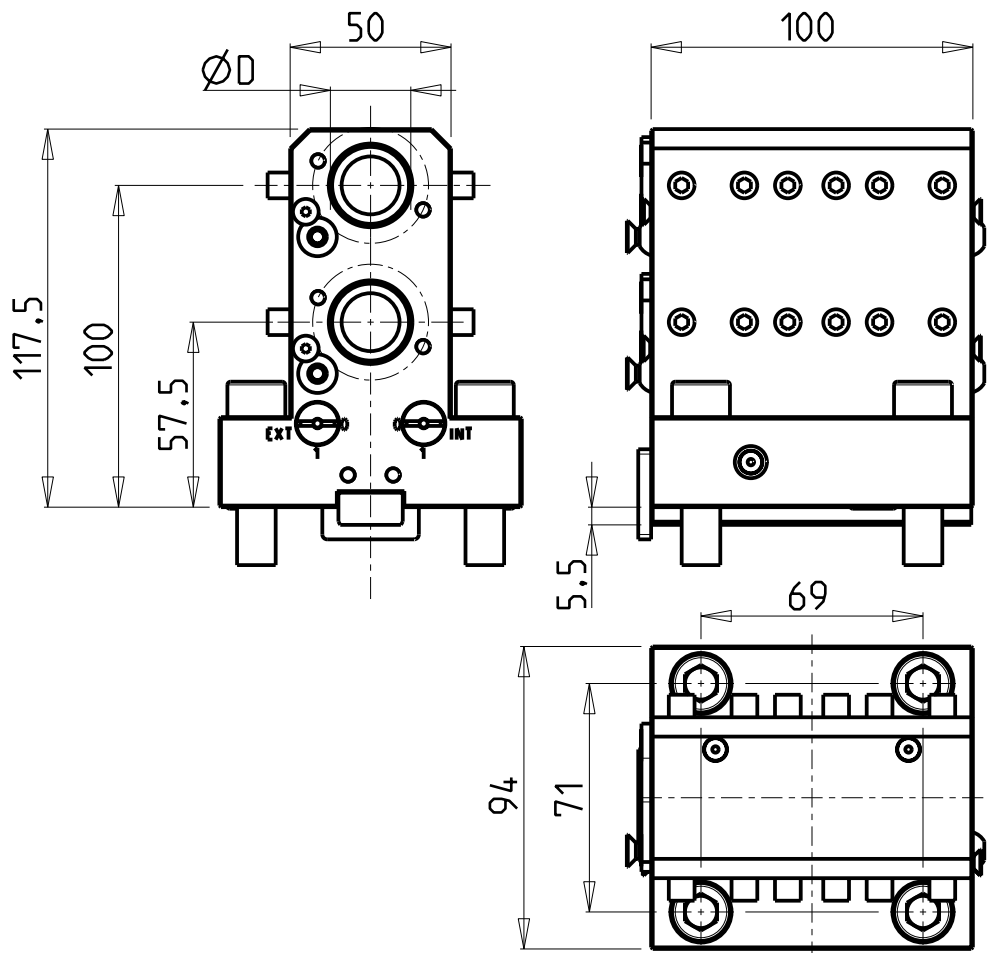
 PAGINA NKM630-3-10

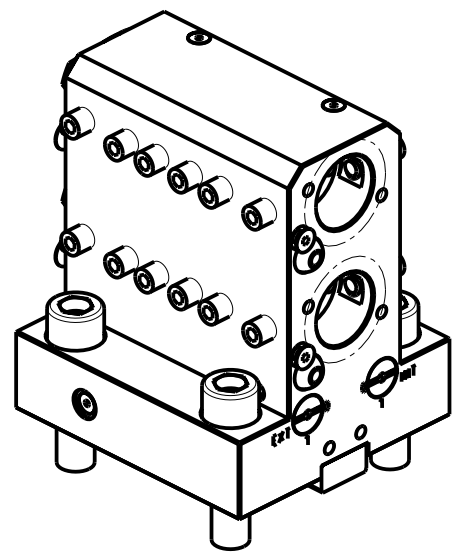
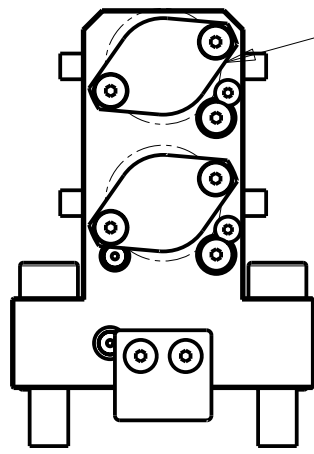

KIT ADDUZIONE INTERNA (OPZIONALE)
 KIT FOR INTERNAL COOLANT (OPTIONAL)
 KIT FUER INTERNE KUEHLMITTELZUFUHR (OPTIONAL)
 Ø25-Ø1" cod. KIT1000006



PER BOCCOLE DI RIDUZIONE VEDI PAG. TBL150-1-00
 FOR REDUCING BUSHINGS SEE PAGE TBL150-1-00
 FÜR REDUZIERBUCHSE SIEHE SEITE TBL150-1-00

Cod. MT	N°Utensili N°Tools N°Werkzeuge	Reversibile lato mandrino/contromandrino Reversible sub/main spindle side Umkehrbare Spindel-seite/ Gegenspindel-seite	Lubrificazione int. opzionale Coolant through optional Innenkuehlung Optional	Lubrificazione est. Ext. coolant Aussenkuehlung	Misure Dimensions Masse	D
NKM0552500	2	X	X	X	mm	25

NAKAMURA-TOME
 WT300 - SC300 - SC30011 - TMC200/300M - SUPER NTX - SUPER NTXL - TW20M/MY/MM/MMY/MYY 12 ST.
 TW30M/MY/MM/MMY/MYY 16 ST.

PORTAUTENSILE ASSIALE PER BARENO 2 POSIZIONI Ø25mm
 Axial double boring bar holder Ø25mm
 Axial Bohrrhalter 2 Positionen Ø25mm

Subject to change without notice.

M.T. srl
 Via Casino Albini 480
 Tel. 0541/956034-957884
 Fax 0541/956341
 47842 S. GIOVANNI IN M. (RN)
 e-mail: mtma@mtmarchetti.com
 http://www.mtmarchetti.com

PRODUZIONE MODULI ROTANTI I



PAGINA NKM864-3-00

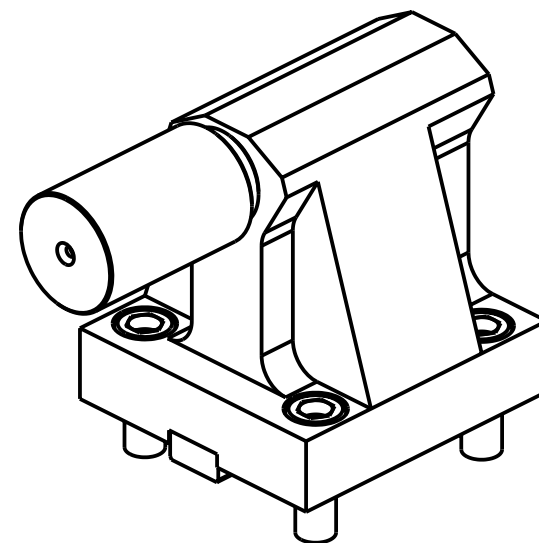
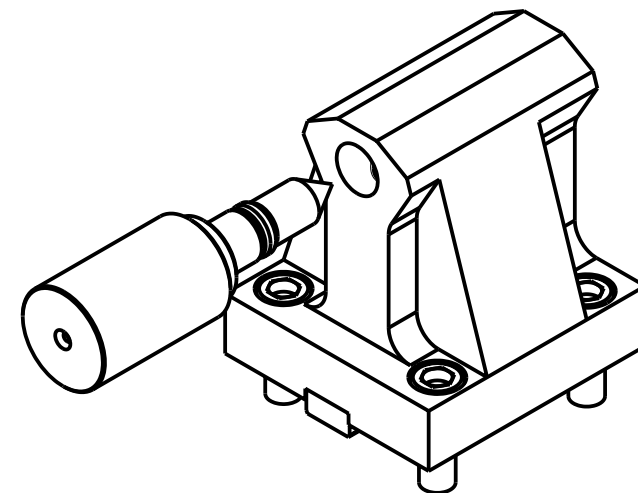
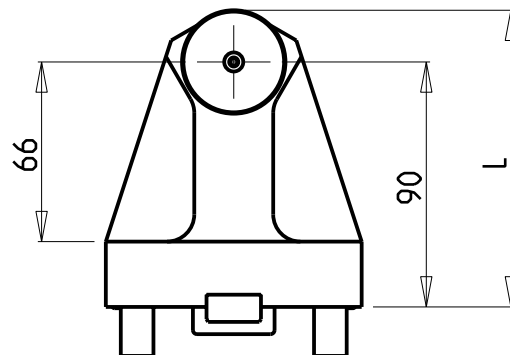
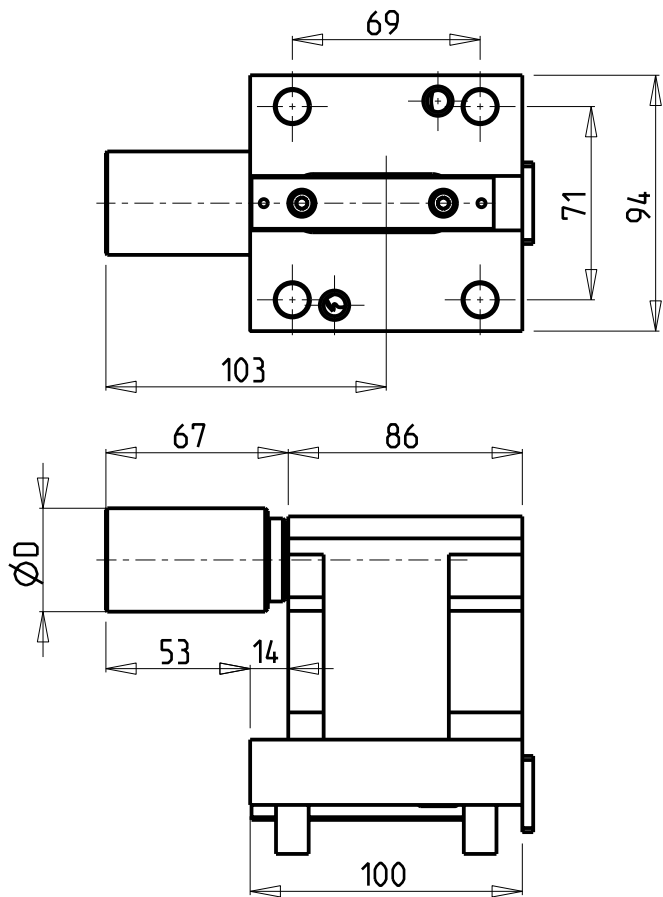

Cod. MT	N°Utensili N° Tools N° Werkzeuge	D	L
NKM1620100	1	38	109
NKM1620100L	1	2"	115.5

NEW

NEW

NAKAMURA-TOME

WT300 - SC300 - SC300II - SUPER NTX - SUPER NTXL

CONTROPUNTA PER CONTROMANDRINO

Tailstock for subspindle

Gegenspitz fuer Gegenspindel

Subject to change without notice.

M.T. srl

Via Casino Albini 480
Tel. 0541/956034-957884
Fax 0541/956341

47842 S. GIOVANNI IN M. (RN)
e-mail: mtma@mtmarchetti.com
<http://www.mtmarchetti.com>

PRODUZIONE MODULI ROTANTI



PAGINA NKM950-3-00

