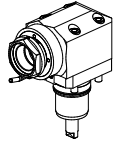
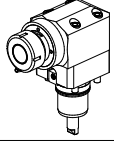
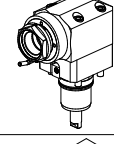
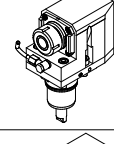
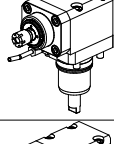
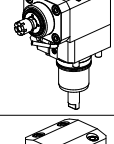
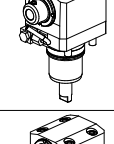
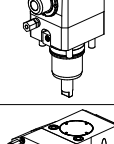
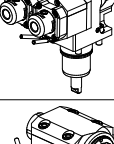
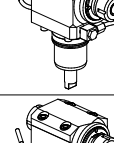
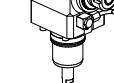
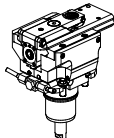
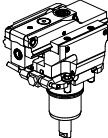
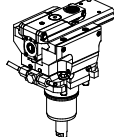
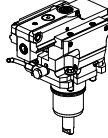
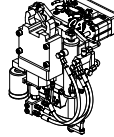
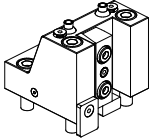
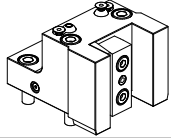
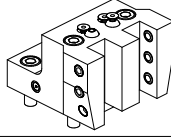
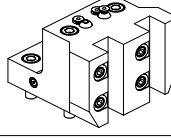
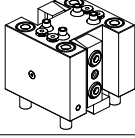
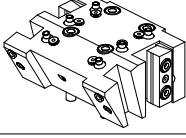
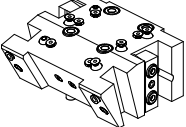
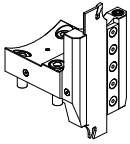
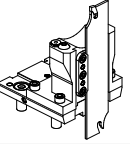
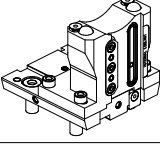
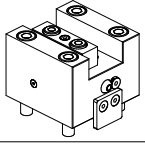
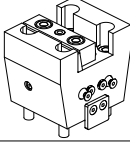
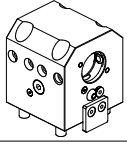
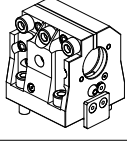
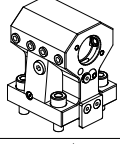
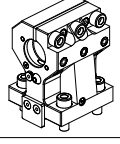
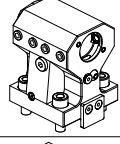
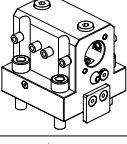
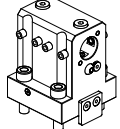

		PAGINA Page Seite
MODULO MOTORIZZATO RADIALE ALTA PRESSIONE Radial driven tool high pressure Radial angetriebenes Werkzeug hochdruck		NKM010.2.20
MODULO MOTORIZZATO RADIALE Radial driven tool Radial angetriebenes Werkzeug		NKM020.2.00
MODULO MOTORIZZATO RADIALE MTSK Radial MTSK driven tool Radial MTSK angetriebenes Werkzeug		NKM020.2.00.K
MODULO MOTORIZZATO RADIALE MOLTIPLICATO 1=1:3 Radial geared-up 1=1:3 driven tool Radial angetriebenes Werkzeug uebersetzt 1=1:3		NKM055.2.00
MODULO MOTORIZZATO RADIALE 2 USCITE IN Y Radial single side twin head driven tool in Y Radial angetriebenes Werkzeug 2 Ausgaenge in Y		NKM090.2.00
MODULO MOTORIZZATO RADIALE ORIENTABILE ±30° DISASSATO 30mm Radial ±30°adjustable angle driven tool re-directed by 30mm Radial angetriebenes Werkzeug schwenkbar ±30° achsversetzt um 30mm		NKM135.2.00
MODULO MOTORIZZATO ASSIALE H=55mm Axial driven tool H=55mm Axial angetriebenes Werkzeug H=55mm		NKM150.2.10
MODULO MOTORIZZATO ASSIALE H=75mm Axial driven tool H=75mm Axial angetriebenes Werkzeug H=75mm		NKM150.2.20
MODULO MOTORIZZATO ASSIALE H=75mm Axial driven tool H=75mm Axial angetriebenes Werkzeug H=75mm		NKM150.2.21
MODULO MOTORIZZATO ASSIALE MTSK H=75mm Axial MTSK driven tool H=75mm Axial MTSK angetriebenes Werkzeug H=75mm		NKM150.2.21.K
MODULO MOTORIZZATO ASSIALE MAGGIORATO H=55mm Axial reinforced driven tool H=55mm Axial angetriebenes Werkzeug vergroessert H=55mm		NKM170.2.10

		PAGINA Page Seite
MODULO MOTORIZZATO ASSIALE MAGGIORATO MTSK H=55mm Axial MTSK reinforced driven tool H=55mm Axial MTSK angetriebenes Werkzeug vergrößert H=55mm		NKM170.2.10.K
MODULO MOTORIZZATO ASSIALE MAGGIORATO H=75mm Axial reinforced driven tool H=75mm Axial angetriebenes Werkzeug vergrößert H=75mm		NKM170.2.20
MODULO MOTORIZZATO ASSIALE MAGGIORATO MTSK H=75mm Axial MTSK reinforced driven tool H=75mm Axial MTSK angetriebenes Werkzeug vergrößert H=75mm		NKM170.2.20.K
MODULO MOTORIZZATO ASSIALE ARRETRATO H=75mm Axial rear-set driven tool H=75mm Axial angetriebenes Werkzeug zurueckversetzt H=75mm		NKM180.2.10
MODULO MOTORIZZATO RADIALE ARRETRATO MTSK H=75mm Radial MTSK rear-set driven tool H=75mm Radial MTSK angetriebenes Werkzeug zurueckversetzt H=75mm		NKM180.2.10.K
MODULO MOTORIZZATO ASSIALE MOLTIPLICATO I=1:3 H=55mm Axial geared-up I=1:3 driven tool H=55mm Axial angetriebenes Werkzeug uebersetzt I=1:3 H=55mm		NKM205.2.10
MODULO MOTORIZZATO ASSIALE MOLTIPLICATO I=1:3 H=75mm Axial geared-up I=1:3 driven tool H=75mm Axial angetriebenes Werkzeug uebersetzt I=1:3 H=75mm		NKM205.2.20
MODULO MOTORIZZATO ASSIALE PER POLIGONATURA INTERNA H=55mm Axial driven tool for internal polygon-making H=55mm Axial angetriebenes Werkzeug fuer interne Facettierung H=55mm		NKM230.2.10
MODULO MOTORIZZATO ASSIALE PER POLIGONATURA INTERNA H=75mm Axial driven tool for internal polygon-making H=75mm Axial angetriebenes Werkzeug fuer interne Facettierung H=75mm		NKM230.2.20
MODULO MOTOR. ASSIALE 2 USCITE IN Y PER POLIGONAT. INTERNA H=75mm Axial single side twin head driven tool in Y for internal polygon-making H=75mm Axial angetriebenes Werkzeug 2 Ausgange in Y fuer interne Facettierung H=75mm		NKM233.2.10
MODULO MOTORIZZATO ASSIALE BISPORGENTE H=55mm Axial opposite face twin driven tool H=55mm Axial angetriebenes Werkzeug halb vorspringend H=55mm		NKM240.2.10
MODULO MOTORIZZATO ASSIALE BISPORGENTE H=75mm Axial opposite face twin driven tool H=75mm Axial angetriebenes Werkzeug halb vorspringend H=75mm		NKM240.2.20

		PAGINA Page Seite
<p>MODULO MOTORIZZATO ASSIALE BISPORGENTE H=75mm Axial opposite face twin driven tool H=75mm Axial angetriebenes Werkzeug halb vorspringend H=75mm</p>		NKM240.2.21
<p>MODULO MOTORIZZATO ASSIALE 2 USCITE IN Y H=55mm Axial single side twin head driven tool in Y H=55mm Axial angetriebenes Werkzeug 2 Ausgaenge in Y H=55mm</p>		NKM260.2.10
<p>MODULO MOTORIZZATO ASSIALE 2 USCITE IN Y H=75mm Axial single side twin head driven tool in Y H=75mm Axial angetriebenes Werkzeug 2 Ausgaenge in Y H=75mm</p>		NKM260.2.20
<p>MODULO MOTORIZZATO ORIENTABILE 0-90° 0-90° adjustable angle driven tool Angetriebenes Werkzeug schwenkbar 0-90°</p>		NKM330.2.00
<p>MODULO MOTORIZZATO ORIENTABILE ±90° ±90° adjustable angle driven tool Angetriebenes Werkzeug schwenkbar ±90°</p>		NKM333.2.00
<p>MODULO MOTORIZZATO ORIENTABILE ±90° CON NONIO DIGITALE ±90° adjustable angle driven tool with digital display Angetriebenes Werkzeug schwenkbar ±90° mit digital display</p>		NKM333.2.01
<p>MODULO MOTORIZZATO ORIENTABILE ±90° ±90° adjustable angle driven tool Angetriebenes Werkzeug schwenkbar ±90°</p>		NKM335.2.00
<p>MODULO MOTORIZZATO ORIENTABILE ±90° CON NONIO DIGITALE ±90° adjustable angle driven tool with digital display Angetriebenes Werkzeug schwenkbar ±90° mit digital display</p>		NKM335.2.01
<p>MODULO MOTORIZZATO ORIENTABILE ±90° MOLTIPLICATO I=1:2 ±90° adjustable angle driven tool geared-up I=1:2 Angetriebenes Werkzeug schwenkbar ±90° uebersetzt I=1:2</p>		NKM336.2.00
<p>MOD. MOTORIZZ ORIENTABILE ±90° MOLTIPL I=1:2 CON NONIO DIGITALE ±90° adjustable angle driven tool geared-up I=1:2 with digital display Angetriebenes Werkzeug schwenkbar +/-90° uebersetzt I=1:2 mit digital display</p>		NKM336.2.01
<p>MODULO MOTORIZZATO PORTACREATORE Driven gear hobber Angetriebenes Zahnradwalzfraes-Werkzeug</p>		NKM340.2.00
<p>MODULO MOTORIZZATO ASSIALE MTSK PER POWER SKIVING H=85mm Axial MTSK driven tool for Power Skiving H=85mm Axial MTSK angetriebenes Werkzeug fuer Power Skiving H=85mm</p>		NKM350.2.00.K

		PAGINA Page Seite
MODULO MOTORIZZATO STOZZATORE CORSA 50mm H=66mm Slotting driven tool 50mm stroke H=66mm Keilnutenstossmaschine 50mm Hub H=66mm		NKM360.2.00
MODULO MOTORIZZATO STOZZATORE CORSA 25mm H=66mm Slotting driven tool 25mm stroke H=66mm Keilnutenstossmaschine 25mm Hub H=66mm		NKM360.2.01
MODULO MOTORIZZATO STOZZATORE CORSA 50mm H=76mm Slotting driven tool 50mm stroke H=76mm Keilnutenstossmaschine 50mm Hub H=76mm		NKM360.2.10
MODULO MOTORIZZATO STOZZATORE CORSA 25mm H=76mm Slotting driven tool 25mm stroke H=76mm Keilnutenstossmaschine 25mm Hub H=76mm		NKM360.2.11
MODULO MOTORIZZATO PER LUNETTA RETRATTILE (TAGLIA 1) Driven toolholder for sliding steady rest (Size 1) Luenettenwerkzeug zurueck versetzte Version (Grossesse 1)		NKM363.2.00
PORTAUTENSILE RADIALE SINGOLO QD=20mm / QD=3/4" Radial single static tool QD=20mm / QD=3/4" Radial Single-Werkzeughalter QD=20mm / QD=3/4"		NKM420.2.00
PORTAUTENSILE RADIALE SINGOLO QD=25mm Radial single static tool QD=25mm Radial Single-Werkzeughalter QD=25mm		NKM423.2.00
PORTAUTENSILE RADIALE SOVRAPPOSTO QD=20mm / QD=3/4" Radial single side twin static tool QD=20mm / QD=3/4" Radial Werkzeughalter ueberlagert QD=20mm / QD=3/4"		NKM440.2.00
PORTAUTENSILE RADIALE SOVRAPPOSTO QD=20mm Radial single side twin static tool QD=20mm Radial Werkzeughalter ueberlagert QD=20mm		NKM440.2.10
PORTAUTENSILE RADIALE DOPPIO QD=20mm / QD=3/4" Radial double static tool QD=20mm / QD=3/4" Radial Doppel-Werkzeughalter QD=20mm / QD=3/4"		NKM450.2.00
PORTAUTENSILE RADIALE MULTIPLO QD=20mm / QD=3/4" Radial multiple static tool QD=20mm / QD=3/4" Radial Mehrfach-Halter QD=20mm / QD=3/4"		NKM470.2.00
PORTAUTENSILE RADIALE MULTIPLO QD=20mm Radial multiple static tool QD=20mm Radial Mehrfach-Halter QD=20mm		NKM470.2.10

		PAGINA Page Seite
PORTAUTENSILE RADIALE PER LAMA Radial blade holder Radial Abstechhalter		NKM510.2.00
PORTAUTENSILE RADIALE PER LAMA Radial blade holder Radial Abstechhalter		NKM520.2.01
PORTAUTENSILE RADIALE PER LAMA CON LUBRIFICAZIONE INTERNA Radial blade holder with internal coolant Radial Abstechhalter mit Innenkuehlung		NKM520.2.05
PORTAUTENSILE ASSIALE SINGOLO QD=20mm / QD=3/4" Axial single static tool QD=20mm / QD=3/4" Axial Single-Werkzeughalter QD=20mm / QD=3/4"		NKM550.2.00
PORTAUTENSILE ASSIALE SINGOLO QD=25mm Axial single static tool QD=25mm Axial Single-Werkzeughalter QD=25mm		NKM552.2.00
PORTAUTENSILE ASSIALE PER BARENO Ø32mm / Ø1 1/4" H=55 mm Axial single boring bar holder Ø32mm / Ø1 1/4" H=55mm Axial Bohrhalter Ø32mm / Ø1 1/4" H=55mm		NKM650.2.10
PORTAUTENSILE ASSIALE PER BARENO Ø32mm / Ø1 1/4" H=55mm Axial single boring bar holder Ø32mm / Ø1 1/4" H=55mm Axial bohrhalter Ø32mm / Ø1 1/4" H=55mm		NKM650.2.20
PORTAUTENSILE ASSIALE PER BARENO Ø40mm / Ø32mm / Ø1 1/4" H=75 mm Axial single boring bar holder Ø40mm / Ø32mm / Ø1 1/4" H=75mm Axial Bohrhalter Ø40mm / Ø32mm / Ø1 1/4" H=75 mm		NKM660.2.10
PORTAUTENSILE ASSIALE PER BARENO Ø40mm / Ø32mm / Ø1 1/4" H=75mm Axial single boring bar holder Ø40mm / Ø32mm / Ø1 1/4" H=75mm Axial Bohrhalter Ø40mm / Ø32mm / Ø1 1/4" H=75mm		NKM660.2.20
PORTAUTENSILE ASSIALE PER BARENO Ø32mm H=80mm Axial single boring bar holder Ø32mm H=80mm Axial Bohrhalter Ø32mm H=80mm		NKM665.2.10
PORTAUTENSILE ASSIALE PER BARENO Ø25mm / Ø1" H=55mm Axial single boring bar holder Ø25mm / Ø1" H=55mm Axial Bohrhalter Ø25mm / Ø1" H=55mm		NKM670.2.10
PORTAUTENSILE ASSIALE PER BARENO Ø25mm / Ø1" H=75mm Axial single boring bar holder Ø25mm / Ø1" H=75mm Axial Bohrhalter Ø25mm / Ø1" H=75mm		NKM680.2.10

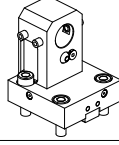
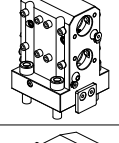
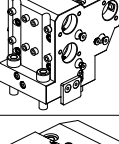
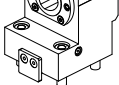
		PAGINA Page Seite
<p>PORTAUTENSILE ASSIALE ARRETRATO PER BARENO $\varnothing 32\text{mm}$ H=75mm</p> <p>Axial single rear set boring bar holder $\varnothing 32\text{mm}$ H=75mm Axial Bohrhalter zurueckversetzt $\varnothing 32\text{mm}$ H=75mm</p>		NKM847.2.10
<p>PORTAUTENSILE ASSIALE ARRETRATO PER BARENO $\varnothing 25\text{mm}$ H=75mm</p> <p>Axial single rear set boring bar holder $\varnothing 25\text{mm}$ H=75mm Axial Bohrhalter zurueckversetzt $\varnothing 25\text{mm}$ H=75mm</p>		NKM848.2.10
<p>PORTAUTENSILE ASSIALE PER BARENO 2 POSIZIONI $\varnothing 25\text{mm}$ / $\varnothing 1"$</p> <p>Axial double boring bar holder $\varnothing 25\text{mm}$ / $\varnothing 1"$ Axial Bohrhalter 2 Positionen $\varnothing 25\text{mm}$ / $\varnothing 1"$</p>		NKM864.2.00
<p>PORTAUTENSILE ASSIALE PER BARENO 2 POSIZIONI $\varnothing 25\text{mm}$ / $\varnothing 1"$</p> <p>Axial double boring bar holder $\varnothing 25\text{mm}$ / $\varnothing 1"$ Axial Bohrhalter 2 Positionen $\varnothing 25\text{mm}$ / $\varnothing 1"$</p>		NKM864.2.10
<p>PORTAUTENSILE ASSIALE PER BARENO 2 POSIZIONI $\varnothing 25\text{mm}$</p> <p>Axial double boring bar holder $\varnothing 25\text{mm}$ Axial Bohrhalter 2 Positionen $\varnothing 25\text{mm}$</p>		NKM864.2.20
<p>PORTAUTENSILE ASSIALE PER BARENO 3 POSIZIONI $\varnothing 25\text{mm}$ / $\varnothing 1"$</p> <p>Axial 3 position boring bar holder $\varnothing 25\text{mm}$ / $\varnothing 1"$ Axial Bohrhalter 3 Positionen $\varnothing 25\text{mm}$ / $\varnothing 1"$</p>		NKM884.2.00
<p>PORTAUTENSILE ASSIALE PER BARENO 3 POSIZIONI $\varnothing 25\text{mm}$</p> <p>Axial 3 position boring bar holder $\varnothing 25\text{mm}$ Axial Bohrhalter 3 Positionen $\varnothing 25\text{mm}$</p>		NKM884.2.10
<p>PORTAUTENSILE ASSIALE PER BARENO 3 POSIZIONI $\varnothing 25\text{mm}$</p> <p>Axial 3 position boring bar holder $\varnothing 25\text{mm}$ Axial Bohrhalter 3 Positionen $\varnothing 25\text{mm}$</p>		NKM884.2.20
<p>PORTAUTENSILE ASSIALE PER BARENO 3 POSIZIONI $\varnothing 20\text{mm}$ / $\varnothing 25\text{mm}$</p> <p>Axial 3 position boring bar holder $\varnothing 20\text{mm}$ / $\varnothing 25\text{mm}$ Axial Bohrhalter 3 Positionen $\varnothing 20\text{mm}$ / $\varnothing 25\text{mm}$</p>		NKM886.2.00
<p>PORTAUTENSILE ASSIALE BISPORGENTE PORTAPINZA H=75mm</p> <p>Axial double collet chuck holder H=75mm Axial Doppel-Spannzangenhalter H=75mm</p>		NKM940.2.00
<p>PORTAUTENSILE RADIALE SINGOLO ARRETRATO MT CAPTO</p> <p>Single rear-set radial static tool MT CAPTO Radial Single-Werkzeughalter zurueckversetzt MT CAPTO</p>		NKM430.B.40
<p>PORTAUTENSILE ASSIALE SINGOLO ARRETRATO MT CAPTO</p> <p>Axial rear-set boring single static tool MT CAPTO Axial Single-Werkzeughalter zurueckversetzt MT CAPTO</p>		NKM555.B.40

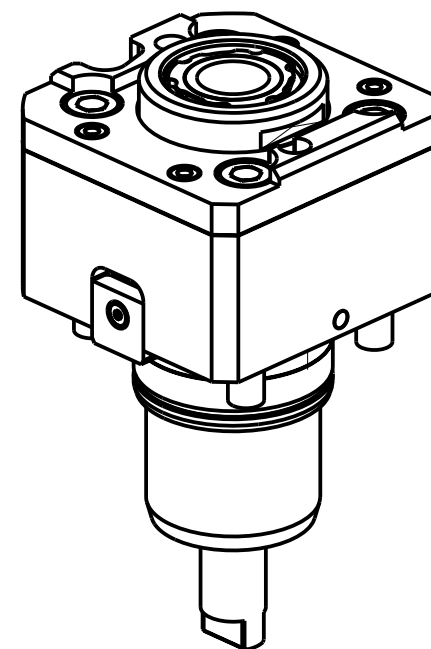
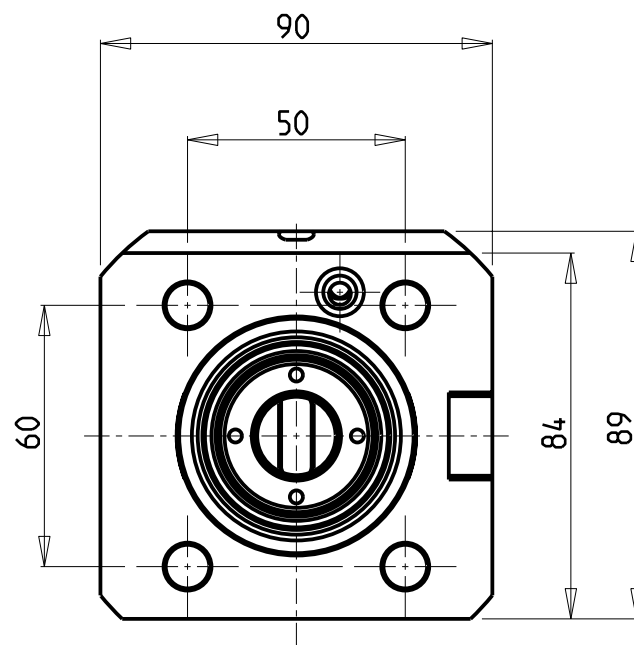
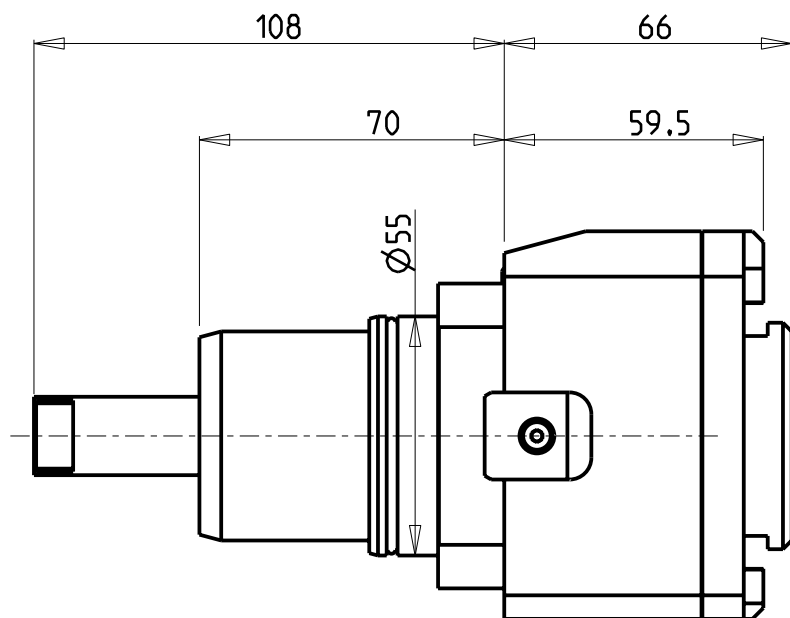

Cod. MT	Mandrino Spindle Spindel	I	RPM	Coppia Max Max Torque Max Drehmoment	Lubrificazione int. Coolant through Innenkuehlung	Lubrificazione est. Ext. coolant Aussenkuehlung	CHIAVI NON INCLUSE Keys not included Schlüssel nicht einbegriffen		
NKM1370132	ERA32	1:1	6000	50Nm	P=70bar	X	CHUB30	CHTAER32ZC *	MNZ0410005 *

- Chiave inclusa
- Key included
- Schlüssel inbegriffen

NAKAMURA-TOME

WT150/250 - WT15011/25011 - WTW150 - WTS150 - SUPER NTM3 - SUPER NTJ - SUPER NTJX - SC150/200/250
 NTY3 150/250 - TW10M/MY/MM/MMY/MMYY-TW20M/MY/MM/MMY/MMYY 16 ST. - WY150/250 - AS200 15/24 ST.

MODULO MOTORIZZATO RADIALE ALTA PRESSIONE

Radial driven tool high pressure
 Radial angetriebenes Werkzeug hochdruck

Subject to change without notice.

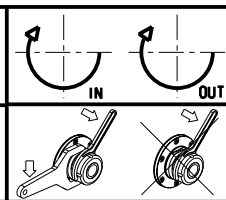

M.T. srl
 Via Casino Albini 480
 Tel. 0541/956034-957884
 Fax 0541/956341
 47842 S. GIOVANNI IN M. (RN)
 e-mail: mtma@mtmarchetti.com
 http://www.mtmarchetti.com

PRODUZIONE MODULI ROTANTI



PAGINA NKM010-2-20

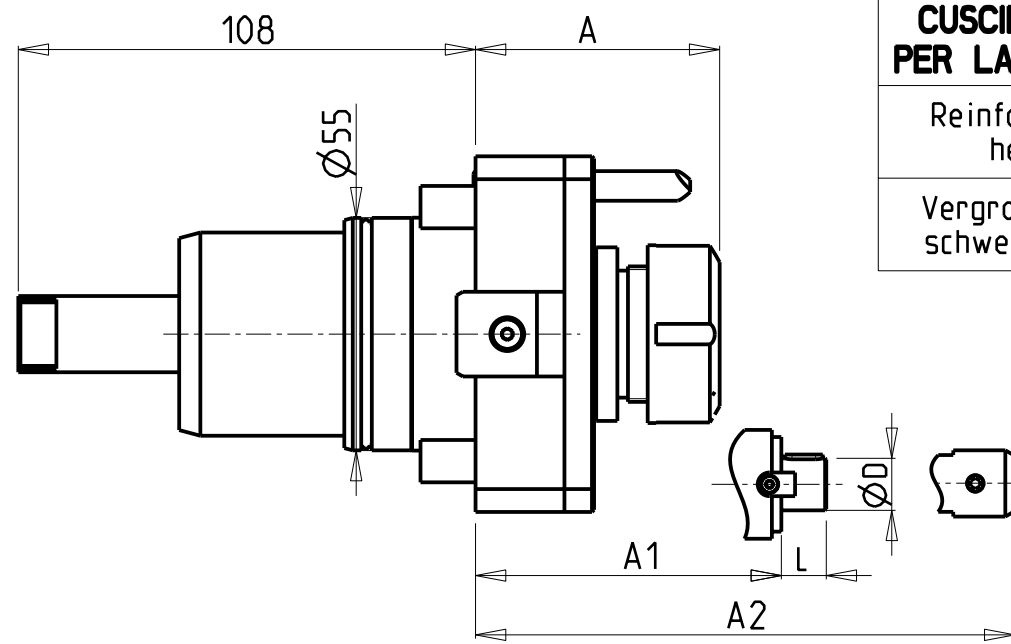
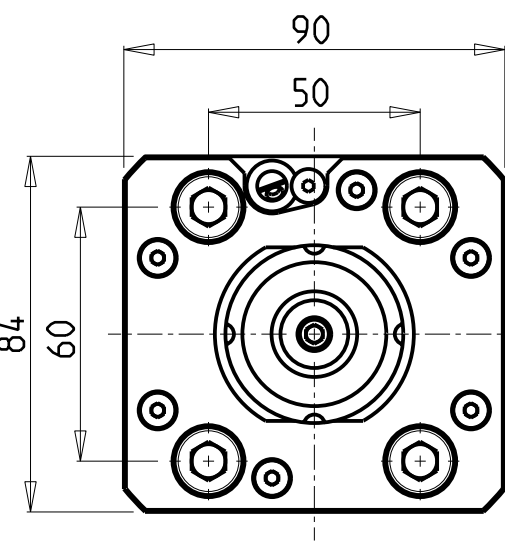

**CUSCINETTI MAGGIORATI
PER LAVORAZIONI PESANTI**

Reinforced bearings for
heavy machining

Vergroesserte Lager fuer
schwerere Bearbeitungen

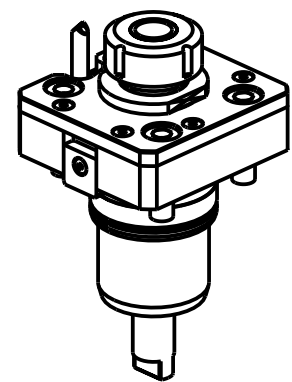
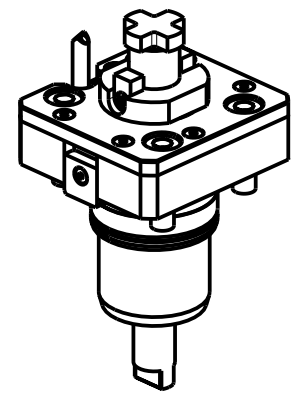
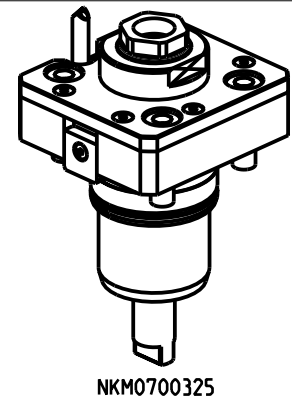

Cod. MT	Mandrino Spindle Spindel	I	RPM	Coppia Max Max Torque Max Drehmoment	Lubrificazione int. Coolant through Innenkuhlung	Lubrificazione est. Ext. coolant Ausseinkuehlung	A	A1	A2	D	L	CHIAVI NON INCLUSE Keys not included Schlüssel nicht einbegriffen	
NKM0700325	ERA25	1:1	6000	50Nm	-	X	51	-	-	-	-	CHUB41	CHUB27
NKM0700125	ER25	1:1	6000	50Nm	-	X	57.16	-	-	-	-	CHUB41	CHSTER25
NKM0700225	ER25	1:1	6000	50Nm	P=30bar	X	68.16	-	-	-	-	CHUB41	CHSTER25
NKM0700132	ER32	1:1	6000	50Nm	-	X	61.66	-	-	-	-	CHUB41	CHSTER32
NKM0700232	ER32	1:1	6000	50Nm	P=30bar	X	73.16	-	-	-	-	CHUB41	CHSTER32
NKM0701617	Ø16x17	1:1	6000	50Nm	-	X	-	38	-	16	17	CHUB41	CH_VTCROCE_M08 •
NKM0702219	Ø22x19	1:1	6000	50Nm	-	X	-	39	-	22	19	CHUB41	CH_VTCROCE_M10 •
NKM0702519	Ø1"x19	1:1	6000	50Nm	-	X	-	42	-	1"	21	CHUB41	CH_VTCROCE_M12 •
NKM0700516	WELDON 16	1:1	6000	50Nm	-	X	-	-	48.5	-	-	-	-

- Chiave inclusa
- Key included
- Schlüssel inbegriffen

NAKAMURA-TOME

WT150/250 - WT15011/25011 - WTW150 - WTS150 - SUPER NTM3 - SUPER NTJ - SUPER NTJX - SC150/200/250
 NTY3 150/250 - TW10M/MY/MM/MMY/MMYY-TW20M/MY/MM/MMY/MMYY 16 ST. - WY 150/250 - AS200 15/24 ST.

MODULO MOTORIZZATO RADIALE
 Radial driven tool
 Radial angetriebenes Werkzeug

Subject to change without notice.

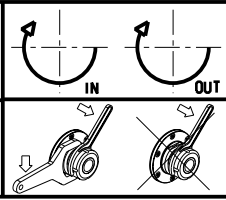

M.T. srl
 Via Casino Albini 480
 Tel. 0541/956034-957884
 Fax 0541/956341
 47842 S. GIOVANNI IN M. (RN)
 e-mail: mtma@mtmarchetti.com
 http://www.mtmarchetti.com

PRODUZIONE MODULI ROTANTI



PAGINA NKM020-2-00

**CUSCINETTI MAGGIORATI
PER LAVORAZIONI PESANTI**

Reinforced bearings for
heavy machining

Vergroesserte Lager fuer
schwerere Bearbeitungen

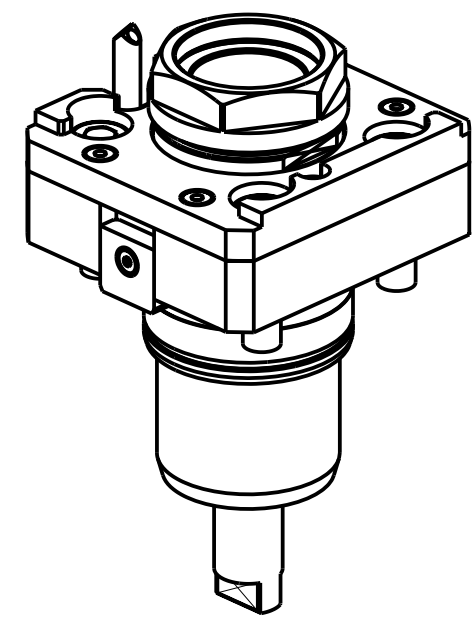
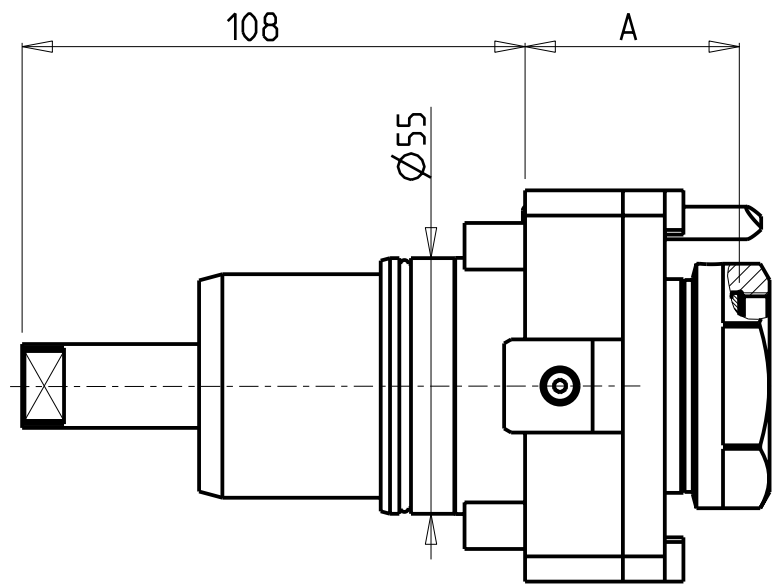
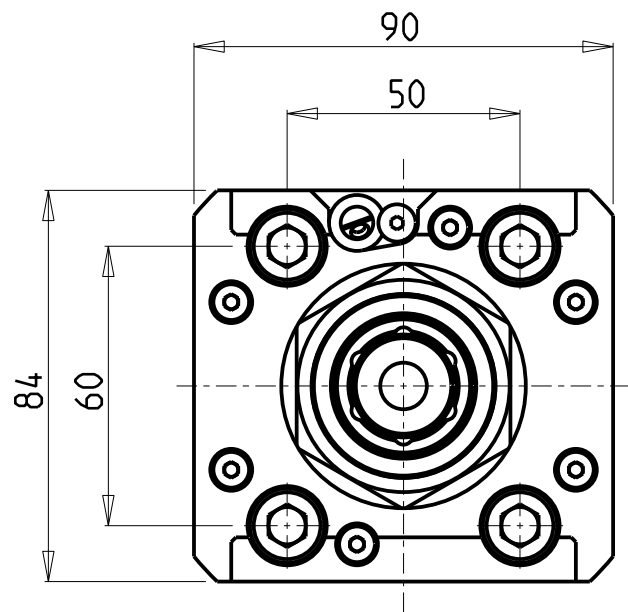

PER PORTAUTENSILI MODULARI MTSK-40 VEDI PAG. TBL300-1-40
FOR MTSK-40 QUIK CHANGE TOOLHOLDERS CLAMPINGS SEE PAGE TBL300-1-40
FUER MTSK-40 MODULARE WERKZEUGAUFNAHMEN SIEHE SEITE TBL300-1-40

Cod. MT	Mandrino Spindle Spindel	I	RPM	Coppia Max Max Torque Max Drehmoment	Lubrificazione int. Coolant through Innenkuhlung	Lubrificazione est. Ext. coolant Aussenkuehlung	A	CHIAVI NON INCLUSE Keys not included Schluessel nicht einbegriffen	
NKM1350140	MTSK-40	1:1	6000	50Nm	-	X	46	CHUB46	OKU0650004 •
NKM1350240	MTSK-40	1:1	6000	50Nm	P=30bar	X	57	CHUB46	OKU0650004 •

- Chiave inclusa
- Key included
- Schluessel inbegriffen

NAKAMURA-TOME

WT150/250 - WT15011/25011 - WTW150 - WTS150 - SUPER NTM3 - SUPER NTJ - SUPER NTJX - SC150/200/250
NTY3 150/250 - TW10M/MY/MM/MMY/MMYY-TW20M/MY/MM/MMY/MMYY 16 ST. - WY 150/250 - AS200 15/24 ST.

MODULO MOTORIZZATO RADIALE MTSK
Radial MTSK driven tool
Radial MTSK angetriebenes Werkzeug

Subject to change without notice.

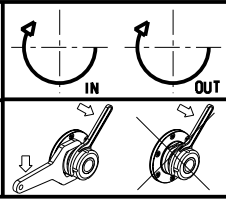

M.T. srl

Via Casino Albini 480
Tel. 0541/956034-957884
Fax 0541/956341
47842 S. GIOVANNI IN M. (RN)
e-mail: mtma@mtmarchetti.com
http://www.mtmarchetti.com

PRODUZIONE MODULI ROTANTI



PAGINA NKM020-2-00-K

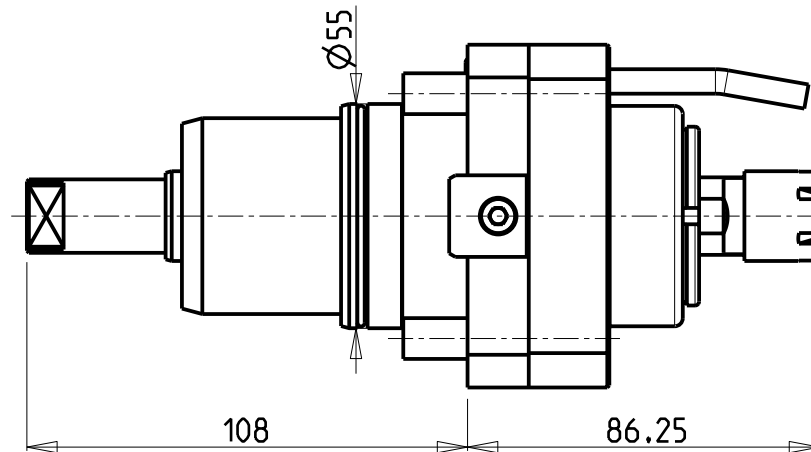
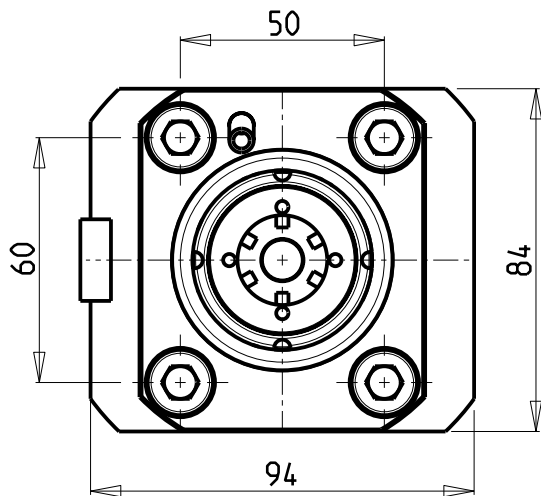

ATTENZIONE - ATTENTION - ACHTUNG

- Per lo smontaggio degli utensili utilizzare sempre la chiave di contrasto come indicato nel manuale d'uso.
- For disassembly of the tools use always the contrast key as mentioned in the user instructions.
- Fuer das Abmontieren der Werkzeuge immer den Gegenschlüssel benutzen wie in der Bedienungsanleitung erwaeht.

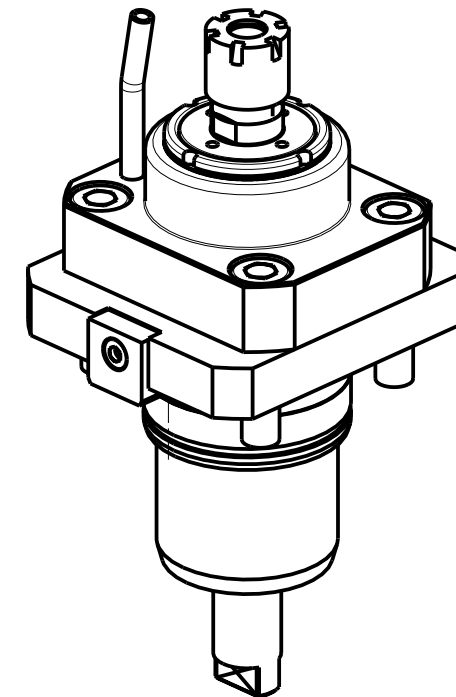

ATTENZIONE - ATTENTION - ACHTUNG

- PRIMA DI UTILIZZARE IL MOTORIZZATO CONSULTARE LE ISTRUZIONI ALLEGATE!
- BEFORE USING THE DRIVEN TOOL, PLEASE CHECK THE ENCLOSED INSTRUCTION SHEET!
- VOR DER BENUTZUNG DES ANGETRIEBENEN WERKZEUGES, DIE BEILIEGENDEN INSTRUKTIONEN DURCHLESEN!

Cod. MT	Mandrino Spindle Spindel	I	RPM	Coppia Max Max Torque Max Drehmoment	Lubrificazione est. Ext. coolant Aussenkuehlung	CHIAVI INCLUDE Keys included Schluessel einbegriffen	
NKM0040016	ER16	1:3	18000	10Nm	X	CHUB17	CHMNER16

NAKAMURA-TOME

WT150/250 - WT15011/25011 - WTW150 - WTS150 - SUPER NTM3 - SUPER NTJ - SUPER NTJX - SC150/200/250
 NTY3 150/250 - TW10M/MY/MM/MMY/MMYY-TW20M/MY/MM/MMY/MMYY 16 ST. - WY 150/250 - AS200 15/24 ST.

MODULO MOTORIZZATO RADIALE Moltiplicato I=1:3

Radial geared-up I=1:3 driven tool

Radial angetriebenes Werkzeug uebersetzt I=1:3

Subject to change without notice.

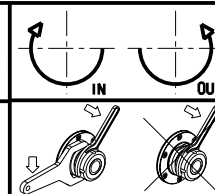

M.T. srl

Via Casino Albini 480
 Tel. 0541/956034-957884
 Fax 0541/956341
 47842 S. GIOVANNI IN M. (RN)
 e-mail: mtma@mtmarchetti.com..
 http://www.mtmarchetti.com

PRODUZIONE MODULI ROTANTI



PAGINA NKM055-2-00

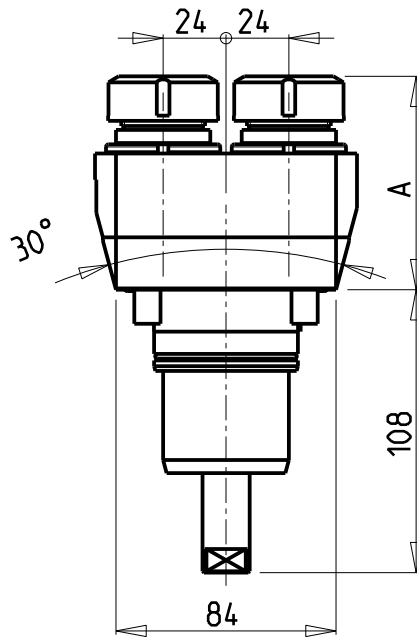
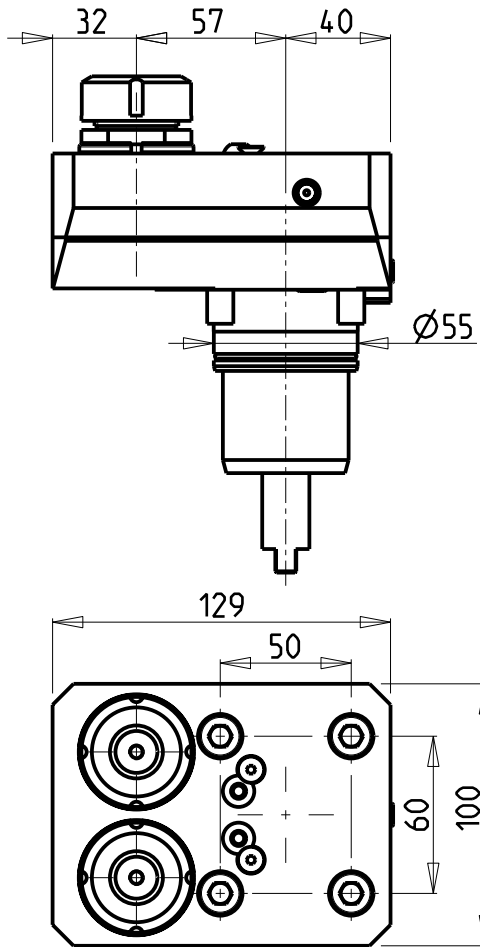

ATTENZIONE - ATTENTION - ACHTUNG

- VERIFICARE LE MISURE DI INGOMBRO PER POSSIBILE INTERFERENZA SU ALCUNI MODELLI DI MACCHINE
- Please check the overall sizes for possible interferences on some machine models
- Bitte überprüfen sie das ausmass um mögliche interferenzen auf einigen maschinen modellen zu vermeiden

ATTENZIONE - ATTENTION - ACHTUNG

- Per lo smontaggio degli utensili utilizzare sempre la chiave di contrasto come indicato nel manuale d'uso.
- For disassembly of the tools use always the contrast key as mentioned in the user instructions.
- Fuer das Abmontieren der Werkzeuge immer den Gegenschlüssel benutzen wie in der Bedienungsanleitung erwaeht.

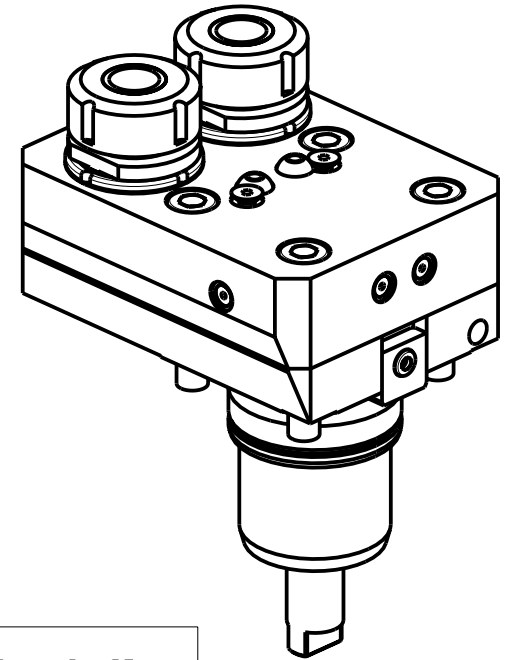

Cod. MT	Mandrino Spindle Spindel	I	RPM	Coppia Max Max Torque Max Drehmoment	Lubrificazione int. Coolant through Innenkuehlung	Lubrificazione est. Ext. coolant Aussenkuehlung	Reversibile lato mandrino/contromandrino Reversible sub/main spindle side Umkehrbare Spindelseite/ Gegenspindelseite	A	CHIAVI NON INCLUDE Keys not included Schluessel nicht inbegriffen	
NKM0320225	ER25	1:1	6000	30Nm	-	X	X	81.46	CHUB36	CHSTER25
NKM0321225	ER25	1:1	6000	30Nm	P=70bar	X	X	94.46	CHUB36	CHSTER25

NEW

NAKAMURA-TOME

WT150/250 - WT150II/250II - WTW150 - WTS150 - SUPER NTM3 - SUPER NTJ - SUPER NTJX - SC150/200/250
 NTY3 150/250 - TW10M/MY/MM/MMY/MYY-TW20M/MY/MM/MMY/MYY 16 ST. - WY 150/250 - AS200MY 15/24 ST.

MODULO MOTORIZZATO RADIALE 2 USCITE IN Y
 Radial single side twin head driven tool in Y
 Radial angetriebenes Werkzeug 2 Ausgaenge in Y

Subject to change without notice.

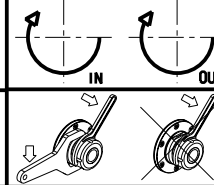

M.T. srl

Via Casino Albini 480
 Tel. 0541/956034-957884
 Fax 0541/956341
 47842 S. GIOVANNI IN M. (RN)
 e-mail: mtma@mtmarchetti.com
 http://www.mtmarchetti.com

PRODUZIONE MODULI ROTANTI



PAGINA NKM090-2-00

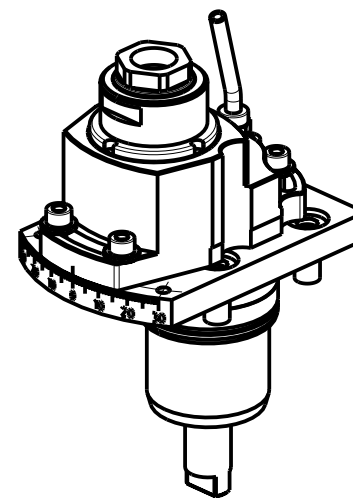
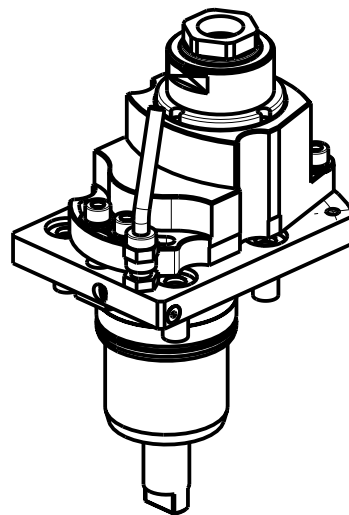
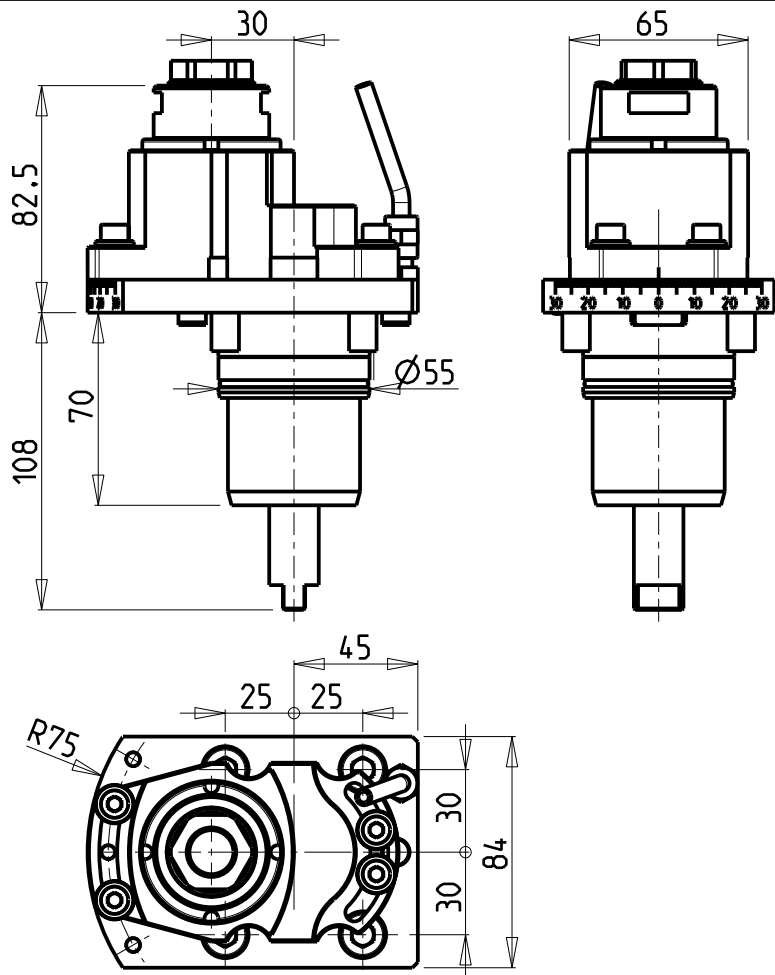

ATTENZIONE - ATTENTION - ACHTUNG

- Per lo smontaggio degli utensili utilizzare sempre la chiave di contrasto come indicato nel manuale d'uso.
- For disassembly of the tools use always the contrast key as mentioned in the user instructions.
- Fuer das Abmontieren der Werkzeuge immer den Gegenschlüssel benutzen wie in der Bedienungsanleitung erwaeht.

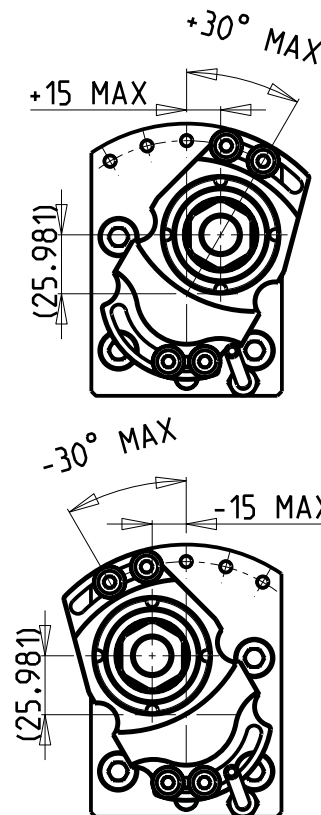

Cod. MT	Mandrino Spindle Spindel	I	RPM	Coppia Max Max Torque Max Drehmoment	Lubrificazione est. Ext. coolant Aussenkuehlung	CHIAVI NON INCLUSE Keys not included Schluessel nicht einbegriffen	
NKM0621025	ERA25	1:1	6000	30Nm	X	CHUB36	CHUB27

NAKAMURA-TOME

WT150/250 - WT15011/25011 - WTW150 - WTS150 - SUPER NTM3 - SUPER NTJ - SUPER NTJX - SC150/200/250
 NTY3 150/250 - TW10M/MY/MM/MMY/MMYY-TW20M/MY/MM/MMY/MMYY 16 ST. - WY 150/250

MODULO MOTORIZZATO RADIALE ORIENTABILE ±30° DISASSATO 30mm

Radial ±30°adjustable angle driven tool re-directed by 30mm

Radial angetriebenes Werkzeug schwenkbar ±30° achsversetzt um 30mm

Subject to change without notice.

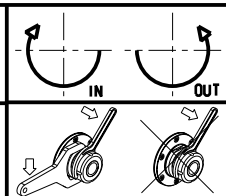

M.T. srl

Via Casino Albini 480
 Tel. 0541/956034-957884
 Fax 0541/956341
 47842 S. GIOVANNI IN M. (RN)
 e-mail: mtma@mtmarchetti.com
 http://www.mtmarchetti.com

PRODUZIONE MODULI ROTANTI



PAGINA NKM135-2-00

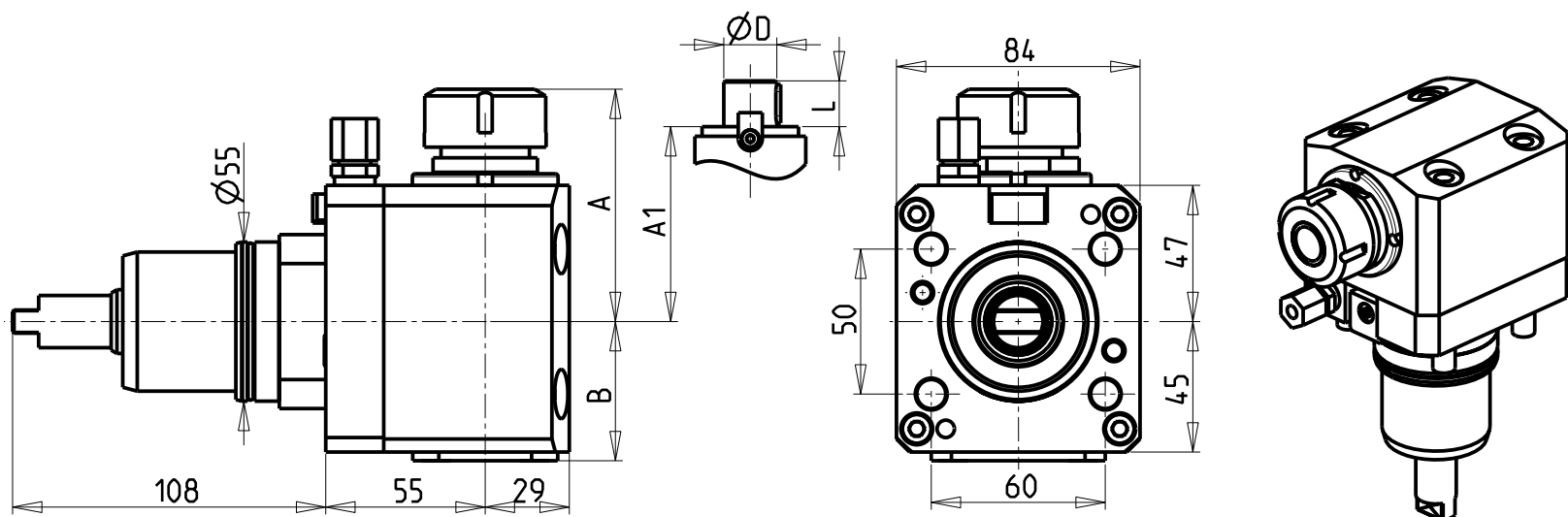

ATTENZIONE - ATTENTION - ACHTUNG

- Per lo smontaggio degli utensili utilizzare sempre la chiave di contrasto come indicato nel manuale d'uso.
- For disassembly of the tools use always the contrast key as mentioned in the user instructions.
- Fuer das Abmontieren der Werkzeuge immer den Gegenschlüssel benutzen wie in der Bedienungsanleitung erwaehnt.

- Chiave inclusa
- Key included
- Schluessel inbegriffen

Cod. MT	Mandrino Spindle Spindel	I	RPM	Coppia Max Max Torque Max Drehmoment	Reversibile lato mandrino/controlmandrino Reversible sub/main spindle side Umkehrbare Spindelseite/Gegenspindelseite	Lubr. interna Coolant through Innenkuehlung	Lubr. esterna Ext. coolant Aussenkuehlung	A	A1	B	D	L	CHIAVI NON INCLUDE Keys not included Schluessel nicht einbegriffen	
NKM0021620	ER20	1:1	6000	50Nm	X		X	80.16	-	48	-	-	CHUB36	CHSTER20
NKM0021820	ER20	1:1	6000	50Nm	X	P=70bar	X	80.16	-	58	-	-	CHUB36	CHSTER20
NKM0021420	ER A 20	1:1	6000	50Nm	X		X	69.23	-	48	-	-	CHUB36	CHUB22
NKM0021425	ER25	1:1	6000	50Nm	X		X	80.16	-	48	-	-	CHUB36	CHSTER25
NKM0021625	ER25	1:1	6000	50Nm	X	P=70bar	X	80.16	-	59	-	-	CHUB36	CHSTER25
NKM0022432	ER32	1:1	6000	50Nm	X		X	92.16	-	48	-	-	CHUB36	CHSTER32
NKM0022532	ER32	1:1	6000	50Nm	X	P=70bar	X	92.16	-	57.5	-	-	CHUB36	CHSTER32
NKM0021617	Ø16x17	1:1	6000	50Nm	X		X	-	63	48	16	17	CHUB36	CH_VTCROCE_M08 ▪
NKM0022219	Ø22x19	1:1	6000	50Nm	X		X	-	63	48	22	19	CHUB36	CH_VTCROCE_M10 ▪
NKM0022721	Ø27x21	1:1	6000	50Nm	X		X	-	65.5	48	27	21	CHUB36	CH_VTCROCE_M12 ▪
NKM0022737	Ø27x37	1:1	6000	50Nm	X		X	-	65.5	48	27	37	CHUB36	CH_VTCROCE_M12 ▪

NAKAMURA-TOME

WT150/250 - WT15011/25011 - WTW150 - WTS150 - SUPER NTM3 - SUPER NTJ - SC150/200/250
 NTY3 150/250 - TW10M/MY/MM/MMY/MMYY-TW20M/MY/MM/MMY/MMYY 16 ST. - WY150/250 - AS200 15/24 ST.

MODULO MOTORIZZATO ASSIALE H=55mm

Axial driven tool H=55mm

Axial angetriebenes Werkzeug H=55mm

Subject to change without notice.

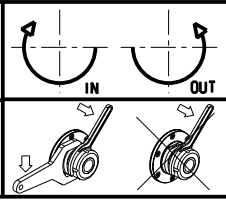

M.T. srl
 Via Casino Albini 480
 Tel. 0541/956034-957884
 Fax 0541/956341
 47842 S. GIOVANNI IN M. (RN)
 e-mail: mtma@tmarchetti.com
 http://www.tmmarchetti.com

PRODUZIONE MODULI ROTANTI



PAGINA NKM150-2-10

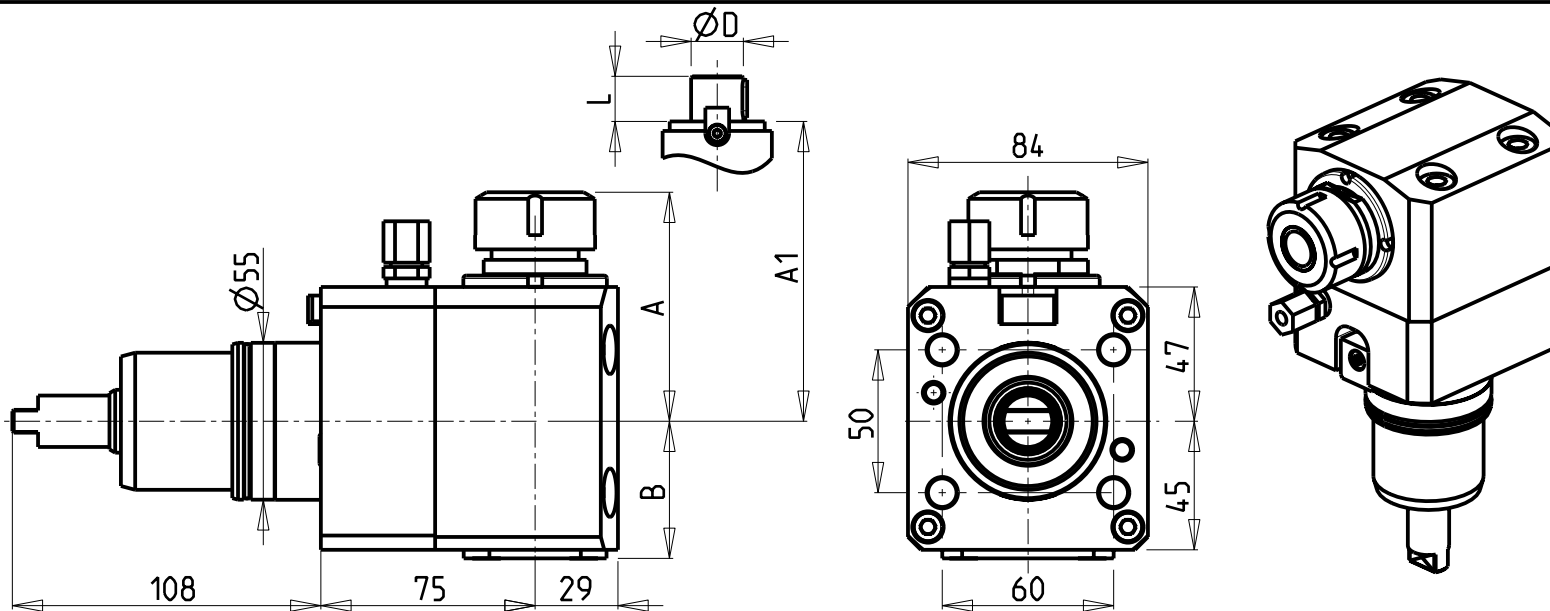

ATTENZIONE - ATTENTION - ACHTUNG

- Per lo smontaggio degli utensili utilizzare sempre la chiave di contrasto come indicato nel manuale d'uso.
- For disassembly of the tools use always the contrast key as mentioned in the user instructions.
- Fuer das Abmontieren der Werkzeuge immer den Gegenschlüssel benutzen wie in der Bedienungsanleitung erwaeht.

- Chiave inclusa
- Key included
- Schluessel inbegriffen

Cod. MT	Mandrino Spindle Spindel	I	RPM	Coppia Max Max Torque Max Drehmoment	Reversibile lato mandrino/contromandrino Reversible sub/main spindle side Umkehrbare Spindel-seite/ Gegenspindel-seite	Lubr.interna Coolant through Innenkuehlung	Lubr. esterna Ext. coolant Aussenkuehlung	A	A1	B	D	L	CHIAVI NON INCLUDE Keys not included Schluessel nicht einbegriffen	
NKM0061620	ER20	1:1	6000	50Nm	X		X	80.16	-	48	-	-	CHUB36	CHSTER20
NKM0061820	ER20	1:1	6000	50Nm	X	P=70bar	X	80.16	-	57.5	-	-	CHUB36	CHSTER20
NKM0061420	ER A 20	1:1	6000	50Nm	X		X	69.23	-	48	-	-	CHUB36	CHUB22
NKM0061425	ER25	1:1	6000	50Nm	X		X	80.16	-	48	-	-	CHUB36	CHSTER25
NKM0061625	ER25	1:1	6000	50Nm	X	P=70bar	X	80.16	-	59	-	-	CHUB36	CHSTER25
NKM0062432	ER32	1:1	6000	50Nm	X		X	92.16	-	48	-	-	CHUB36	CHSTER32
NKM0062532	ER32	1:1	6000	50Nm	X	P=70bar	X	92.16	-	57.5	-	-	CHUB36	CHSTER32
NKM0061617	Ø16x17	1:1	6000	50Nm	X		X	-	63	48	16	17	CHUB36	CH_VTCROCE_M08 ▪
NKM0062219	Ø22x19	1:1	6000	50Nm	X		X	-	63	48	22	19	CHUB36	CH_VTCROCE_M10 ▪
NKM0062721	Ø27x21	1:1	6000	50Nm	X		X	-	65.5	48	27	21	CHUB36	CH_VTCROCE_M12 ▪

NAKAMURA - TOME

WT250 - WT15011/25011 - WTW150 - WTS150 - SC150/200/250 - SUPER NTJX - NTY3 150/250 - AS200 15 ST.

MODULO MOTORIZZATO ASSIALE H=75mm

Axial driven tool H=75mm

Axial angetriebenes Werkzeug H=75mm

Subject to change without notice.

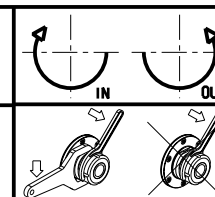

M.T. srl

Via Casino Albini 480
Tel. 0541/956034-957884
Fax 0541/956341
47842 S. GIOVANNI IN M. (RN)
e-mail: mtma@mtmarchetti.com
http://www.mtmarchetti.com

PRODUZIONE MODULI ROTANTI



PAGINA NKM150-2-20

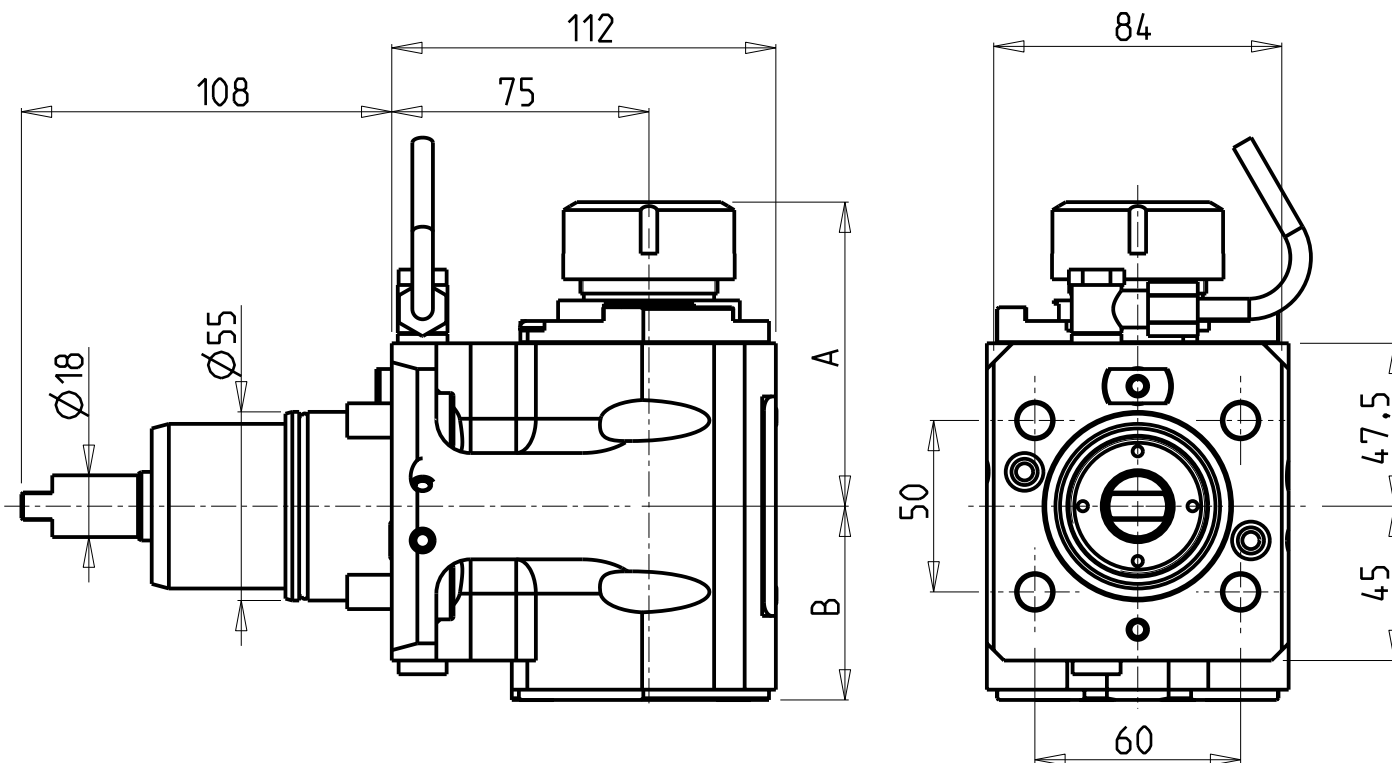

ATTENZIONE - ATTENTION - ACHTUNG

- Per lo smontaggio degli utensili utilizzare sempre la chiave di contrasto come indicato nel manuale d'uso.
- For disassembly of the tools use always the contrast key as mentioned in the user instructions.
- Fuer das Abmontieren der Werkzeuge immer den Gegenschlüssel benutzen wie in der Bedienungsanleitung erwaeht.

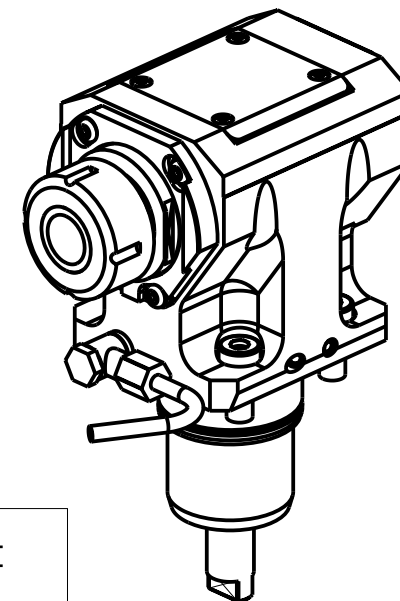

- Chiave inclusa
- Key included
- Schluessel inbegriffen

Cod. MT	Mandrino Spindel Spindel	I	RPM	Coppia Max Max Torque Max Drehmoment	Reversibile lato mandrino/contromandrino Reversible sub/main spindle side Umkehrbare Spindel-seite/ Gegenspindel-seite	Lubr.interna Coolant through Innenkuehlung	Lubr. esterna Ext. coolant Aussenkuehlung	A	B	CHIAVI NON INCLUSE Keys not included Schluessel nicht einbegriffen	
NKM1390132	ER32	1:1	6000	50Nm	X	-	X	88.7	56.5	CHSTER32	OKU0650004
NKM1390140	ER40	1:1	6000	50Nm	X	-	X	99.2	56.5	CHSTER40	OKU0650004
NKM1390232	ER32	1:1	6000	50Nm	X	P=70bar	X	88.7	67.5	CHSTER32	OKU0650004
NKM1390240	ER40	1:1	6000	50Nm	X	P=70bar	X	99.2	67.5	CHSTER40	OKU0650004

NAKAMURA-TOME

WT250 - WT15011/25011 - WTW150 - WTS150 - SC150/200/250 - SUPER NTJX - NTY3 150/250 - AS200 15 ST.

MODULO MOTORIZZATO ASSIALE H=75mm

Axial driven tool H=75mm

Axial angetriebenes Werkzeug H=75mm

Subject to change without notice.

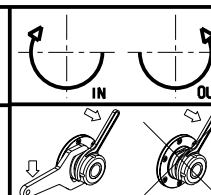

M.T. srl

Via Casino Albini 480
Tel. 0541/956034-957884
Fax 0541/956341
47842 S. GIOVANNI IN M. (RN)
e-mail: mtma@mtmarchetti.com
http://www.mtmarchetti.com

PRODUZIONE MODULI ROTANTI



PAGINA NKM150-2-21

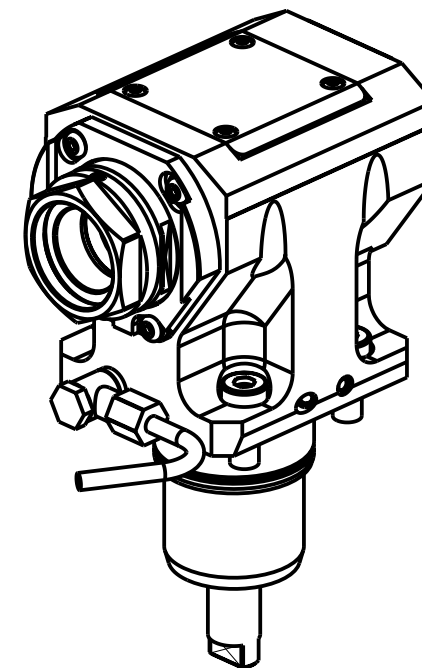
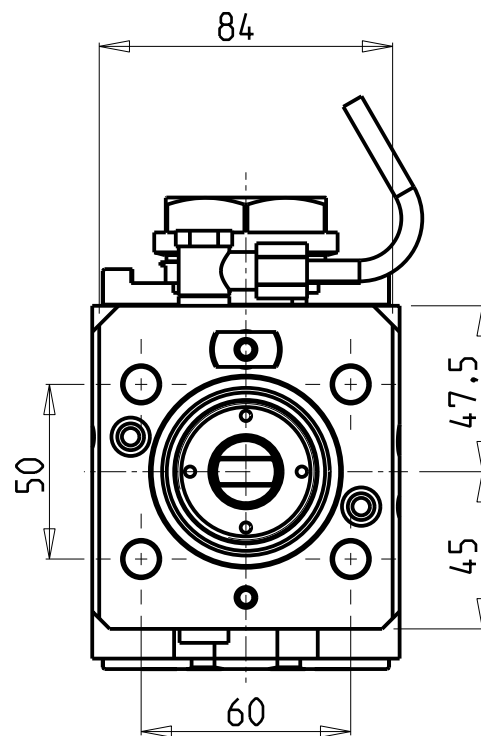
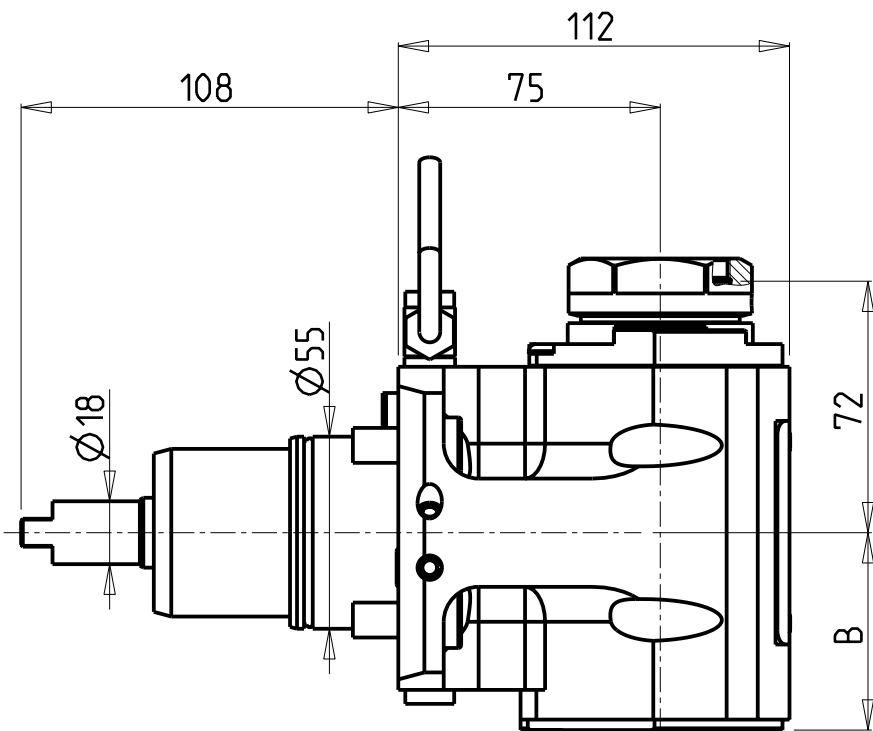

PER PORTAUTENSILI MODULARI MTSK-40 VEDI PAG. TBL300-1-40
 FOR MTSK-40 QUICK CHANGE TOOLHOLDERS CLAMPINGS SEE PAGE TBL300-1-40
 FUER MTSK-40 MODULARE WERKZEUGAUFNAHMEN SIEHE SEITE TBL300-1-40

Cod. MT	Mandrino Spindle Spindel	I	RPM	Coppia Max Max Torque Max Drehmoment	Reversibile lato mandrino/contromandrino Reversible sub/main spindle side Umkehrbare Spindel-seite/ Gegenspindel-seite	Lubrificazione int. Coolant through Innenkuehlung	Lubrificazione est. Ext. coolant Aussenkuehlung	B	CHIAVI NON INCLUDE Keys not included Schluessel nicht einbegriffen	
NKM1410140	MTSK-40	1:1	6000	50Nm	X	-	X	56.5	CHUB46	OKU0650004 *
NKM1410240	MTSK-40	1:1	6000	50Nm	X	P=70bar	X	67.5	CHUB46	OKU0650004 *

- Chiave inclusa
- Key included
- Schluessel inbegriffen

NAKAMURA-TOME

WT250 - WT15011/25011 - WTW150 - WTS150 - SC150/200/250 - SUPER NTJX - NTY3 150/250 - AS200 15 ST.

MODULO MOTORIZZATO ASSIALE MTSK H=75mm

Axial MTSK driven tool H=75mm

Axial MTSK angetriebenes Werkzeug H=75mm

Subject to change without notice.

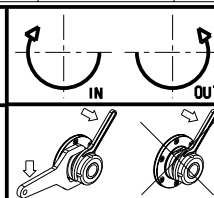

M.T. srl

Via Casino Albini 480
 Tel. 0541/956034-957884
 Fax 0541/956341
 47842 S. GIOVANNI IN M. (RN)
 e-mail: mtma@mtmarchetti.com
 http://www.mtmarchetti.com

PRODUZIONE MODULI ROTANTI



PAGINA NKM150-2-21-K

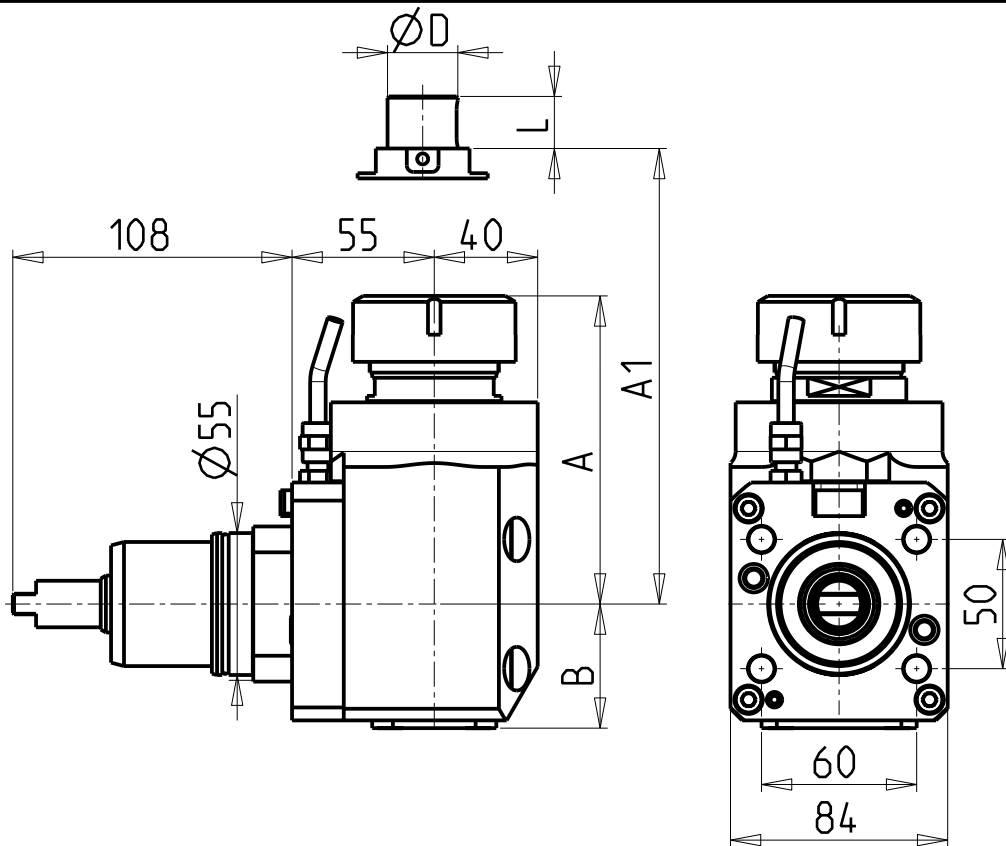

CUSCINETTI MAGGIORATI PER LAVORAZIONI PESANTI

Reinforced bearings for
heavy machining

Vergroesserte Lager fuer
schwerere Bearbeitungen

ATTENZIONE - ATTENTION - ACHTUNG

- Per lo smontaggio degli utensili utilizzare sempre la chiave di contrasto come indicato nel manuale d'uso.
- For disassembly of the tools use always the contrast key as mentioned in the user instructions.
- Fuer das Abmontieren der Werkzeuge immer den Gegenschlüssel benutzen wie in der Bedienungsanleitung erwaeht.

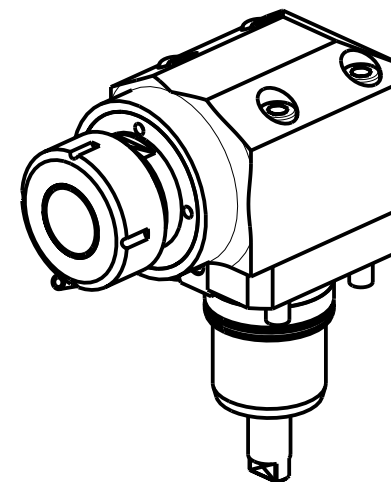

- Chiave inclusa
- Key included
- Schlüssel inbegriffen

Cod. MT	Mandrino Spindel Spindel	I	RPM	Coppia Max Max Torque Max Drehmoment	Reversibile lato mandrino/contromandrino Reversible sub/main spindle side Umkehrbare Spindel-seite/ Gegenspindel-seite	Lubr.interna Coolant through Innenkuehlung	Lubrificazione est. Ext. coolant Aussenkuehlung	A	B	A1	ØD	L	CHIAVI NON INCLUDE Keys not included Schlüssel nicht einbegriffen	
NKM0070140	ER40	1:1	6000	50Nm	X	-	X	119.16	48	-	-	-	CHUB46	CHSTER40
NKM0070240	ER40	1:1	6000	50Nm	X	P=70bar	X	119.16	58	-	-	-	CHUB46	CHSTER40
NKM0072519	Ø1" x19	1:1	6000	50Nm	X	-	X	-	48	91.5	1"	19	CHUB46	CH_VTCROCE_M12 ▪
NKM0072721	Ø27x21	1:1	6000	50Nm	X	-	X	-	48	91.5	27	20	CHUB36	CH_VTCROCE_M12 ▪

NAKAMURA-TOME

WT150/250 - WT15011/25011 - WTW150 - WTS150 - SUPER NTM3 - SUPER NTJ - SC150/200/250
 NTY3 150/250 - TW10M/MY/MM/MMY/MMYY-TW20M/MY/MM/MMY/MMYY 16 ST. - WY150/250 - AS200 15/24 ST.

MODULO MOTORIZZATO ASSIALE MAGGIORATO H=55mm

Axial reinforced driven tool H=55mm

Axial angetriebenes Werkzeug vergroessert H=55mm

Subject to change without notice.

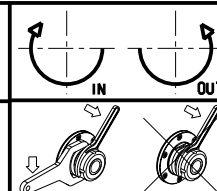

M.T. srl

Via Casino Albini 480
 Tel. 0541/956034-957884
 Fax 0541/956341
 47842 S. GIOVANNI IN M. (RN)
 e-mail: mtma@mtmarchetti.com
 http://www.mtmarchetti.com

PRODUZIONE MODULI ROTANTI



PAGINA NKM170-2-10

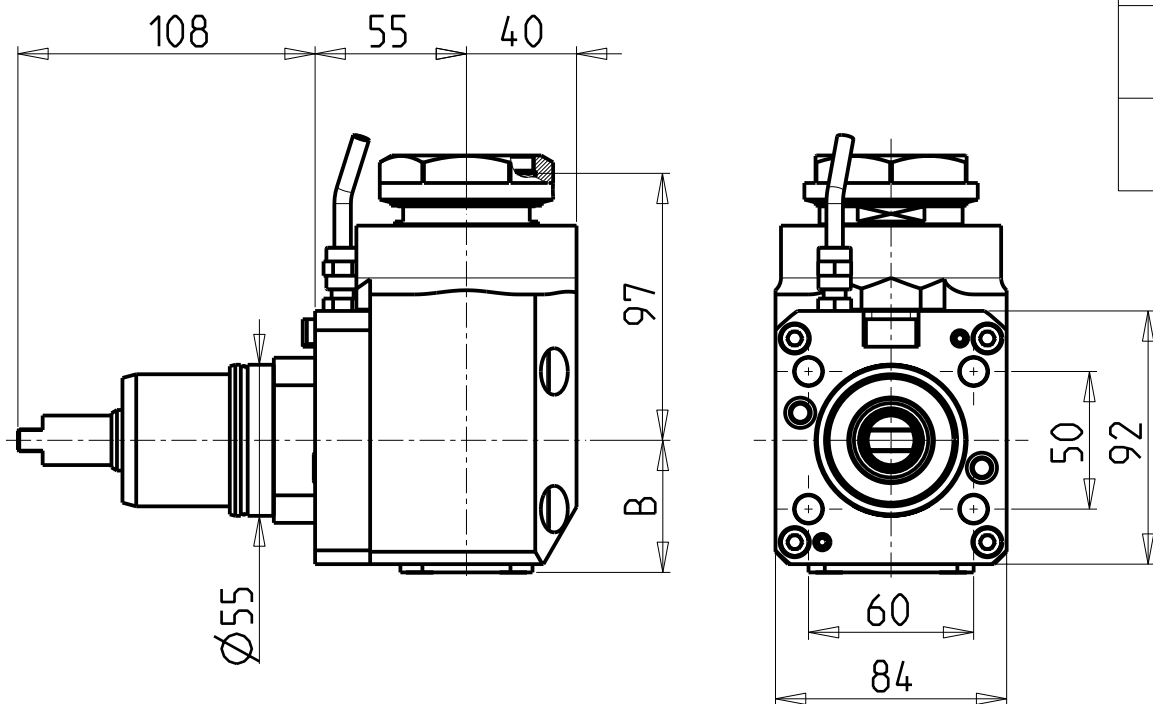

CUSCINETTI MAGGIORATI PER LAVORAZIONI PESANTI

Reinforced bearings for
heavy machining

Vergroesserte Lager fuer
schwerere Bearbeitungen

ATTENZIONE - ATTENTION - ACHTUNG

- Per lo smontaggio degli utensili utilizzare sempre la chiave di contrasto come indicato nel manuale d'uso.
- For disassembly of the tools use always the contrast key as mentioned in the user instructions.
- Fuer das Abmontieren der Werkzeuge immer den Gegenschlüssel benutzen wie in der Bedienungsanleitung erwaeht.

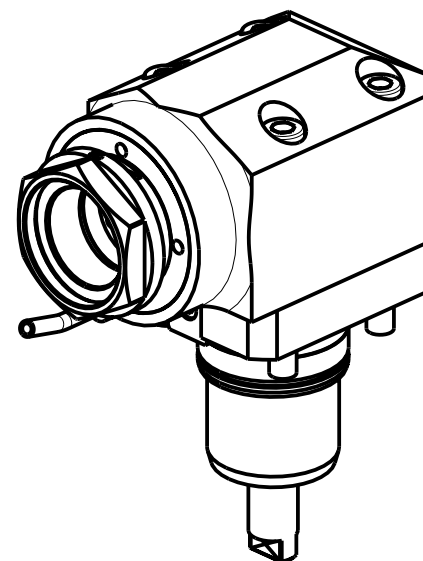

PER PORTAUTENSILI MODULARI MTSK-50 VEDI PAG. TBL300-1-50
FOR MTSK-50 QUIK CHANGE TOOLHOLDERS CLAMPINGS SEE PAGE TBL300-1-50
FUER MTSK-50 MODULARE WERKZEUGAUFNAHMEN SIEHE SEITE TBL300-1-50

Cod. MT	Mandrino Spindle Spindel	I	RPM	Coppia Max Max Torque Max Drehmoment	Reversibile lato mandrino/contromandrino Reversible sub/main spindle side Umkehrbare Spindel-seite/ Gegenspindel-seite	Lubr.interna Coolant through Innenkuehlung	Lubrificazione est. Ext. coolant Aussenkuehlung	B	CHIAVI NON INCLUSE Keys not included Schlüssel nicht einbegriffen	
NKM1000150	MTSK-50	1:1	6000	50Nm	X	-	X	48	CHUB46	CHUB55
NKM1000250	MTSK-50	1:1	6000	50Nm	X	P=70bar	X	58	CHUB46	CHUB55

NAKAMURA-TOME

WT150/250 - WT15011/25011 - WTW150 - WTS150 - SUPER NTM3 - SUPER NTJ - SC150/200/250
NTY3 150/250 - TW10M/MY/MM/MMY/MMYY-TW20M/MY/MM/MMY/MMYY 16 ST. - WY 150/250 - AS200 15/24 ST.

MODULO MOTORIZZATO ASSIALE MAGGIORATO MTSK H=55mm

Axial MTSK reinforced driven tool H=55mm

Axial MTSK angetriebenes Werkzeug vergroessert H=55mm

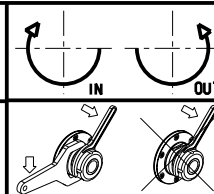

M.T. srl

Via Casino Albini 480
Tel. 0541/956034-957884
Fax 0541/956341
47842 S. GIOVANNI IN M. (RN)
e-mail: mtma@tmarchetti.com
http://www.tmmarchetti.com

PRODUZIONE MODULI ROTANTI



PAGINA NKM170-2-10-K

Subject to change without notice.

10/2018

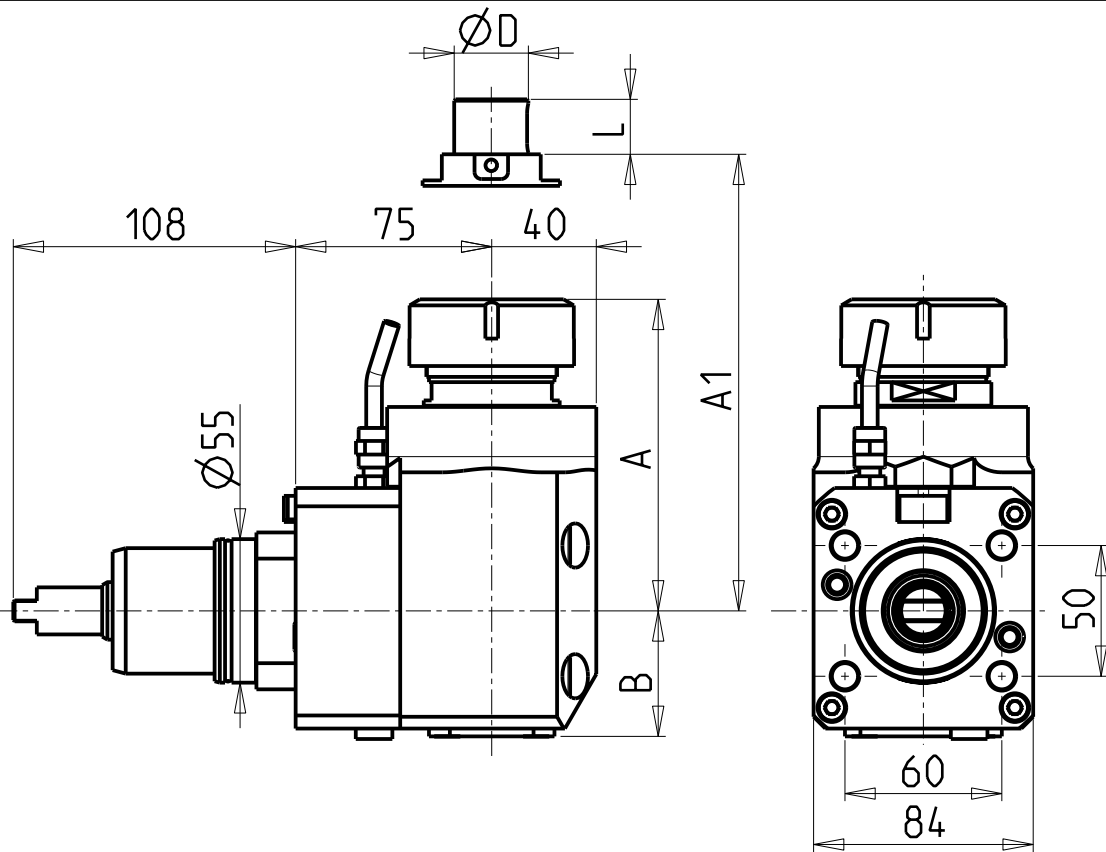

**CUSCINETTI MAGGIORATI
PER LAVORAZIONI PESANTI**

Reinforced bearings for
heavy machining

Vergroesserte Lager fuer
schwerere Bearbeitungen

ATTENZIONE - ATTENTION - ACHTUNG

- Per lo smontaggio degli utensili utilizzare sempre la chiave di contrasto come indicato nel manuale d'uso.
- For disassembly of the tools use always the contrast key as mentioned in the user instructions.
- Fuer das Abmontieren der Werkzeuge immer den Gegenschlüssel benutzen wie in der Bedienungsanleitung erwaeht.

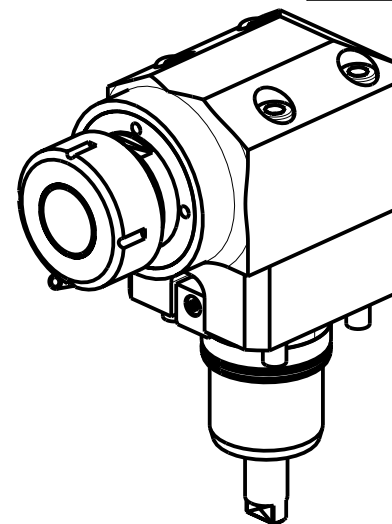

- Chiave inclusa
- Key included
- Schlüssel einbegriffen

Cod. MT	Mandrino Spindel Spindel	I	RPM	Coppia Max Max Torque Max Drehmoment	Reversibile lato mandrino/contromandrino Reversible sub/main spindle side Umkehrbare Spindel-seite/Gegenspindel-seite	Lubr.interna Coolant through Innenkuehlung	Lubrificazione est. Ext. coolant Aussenkuehlung	A	B	A1	ØD	L	CHIAVI NON INCLUDE Keys not included Schluessel nicht einbegriffen	
													CHUB46	CHSTER40
NKM0990140	ER40	1:1	6000	50Nm	X	-	X	119.16	48	-	-	-	CHUB46	CHSTER40
NKM0990240	ER40	1:1	6000	50Nm	X	P=70bar	X	119.16	58	-	-	-	CHUB46	CHSTER40
NKM0992519	Ø1" x19	1:1	6000	50Nm	X	-	X	-	48	91.5	1"	19	CHUB46	CH_VTCROCE_M12 *
NKM0992721	Ø27x21	1:1	6000	50Nm	X	-	X	-	48	91.5	27	20	CHUB36	CH_VTCROCE_M12 *

NAKAMURA-TOME

WT250 - WT15011/25011 - WTW150 - WTS150 - SC150/200/250 - SUPER NTJX - NTY3 150/250

MODULO MOTORIZZATO ASSIALE MAGGIORATO H=75mm

Axial reinforced driven tool H=75mm

Axial angetriebenes Werkzeug vergroessert H=75mm

Subject to change without notice.

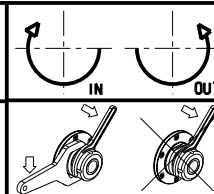

M.T. srl

Via Casio Albini 480
Tel. 0541/956034-957884
Fax 0541/956341

47842 S. GIOVANNI IN M. (RN)
e-mail: mtma@tmarchetti.com
http://www.tmmarchetti.com

PRODUZIONE MODULI ROTANTI



PAGINA NKM170-2-20

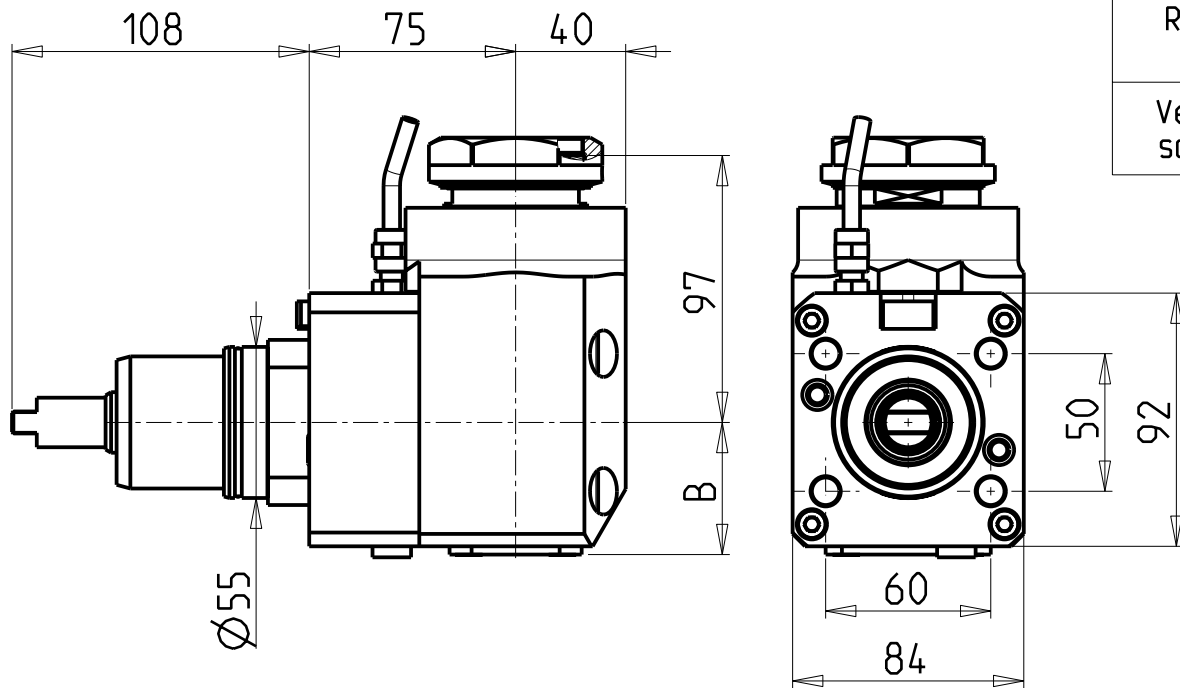

CUSCINETTI MAGGIORATI PER LAVORAZIONI PESANTI

Reinforced bearings for
heavy machining

Vergroesserte Lager fuer
schwerere Bearbeitungen

ATTENZIONE - ATTENTION - ACHTUNG

- Per lo smontaggio degli utensili utilizzare sempre la chiave di contrasto come indicato nel manuale d'uso.
- For disassembly of the tools use always the contrast key as mentioned in the user instructions.
- Fuer das Abmontieren der Werkzeuge immer den Gegenschlüssel benutzen wie in der Bedienungsanleitung erwaehnt.

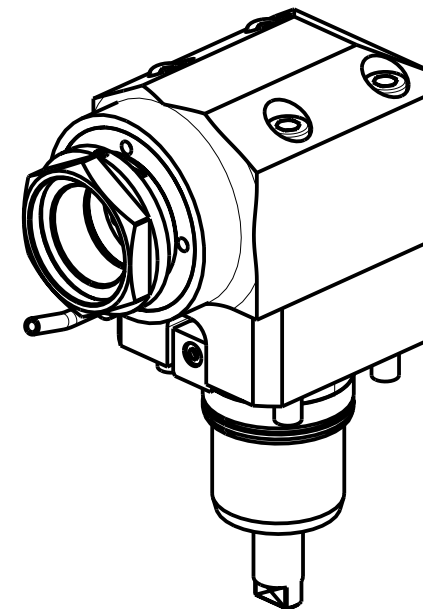

PER PORTAUTENSILI MODULARI MTSK-50 VEDI PAG. TBL300-1-50
FOR MTSK-50 QUIK CHANGE TOOLHOLDERS CLAMPINGS SEE PAGE TBL300-1-50
FUER MTSK-50 MODULARE WERKZEUGAUFNAHMEN SIEHE SEITE TBL300-1-50

Cod. MT	Mandrino Spindle Spindel	I	RPM	Coppia Max Max Torque Max Drehmoment	Reversibile lato mandrino/controlmandrino Reversible sub/main spindle side Umkehrbare Spindel-seite/Gegenspindel-seite	Lubr.interna Coolant through Innenkuehlung	Lubrificazione est. Ext. coolant Aussenkuehlung	B	CHIAVI NON INCLUSE Keys not included Schlüssel nicht einbegriffen	
NKM1010150	MTSK-50	1:1	6000	50Nm	X	-	X	48	CHUB46	CHUB55
NKM1010250	MTSK-50	1:1	6000	50Nm	X	P=70bar	X	58	CHUB46	CHUB55

NAKAMURA-TOME

WT250 - WT15011/25011 - WTW150 - WTS150 - SC150/200/250 - SUPER NTJX - NTY3 150/250

MODULO MOTORIZZATO ASSIALE MAGGIORATO MTSK H=75mm

Axial MTSK reinforced driven tool H=75mm

Axial MTSK angetriebenes Werkzeug vergroessert H=75mm

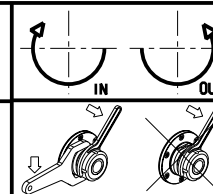

M.T. srl

Via Casino Albini 480
Tel. 0541/956034-957884
Fax 0541/956341
47842 S. GIOVANNI IN M. (RN)
e-mail: mtma@mtmarchetti.com
http://www.mtmarchetti.com

PRODUZIONE MODULI ROTANTI



PAGINA NKM170-2-20-K

Subject to change without notice.

10/2018

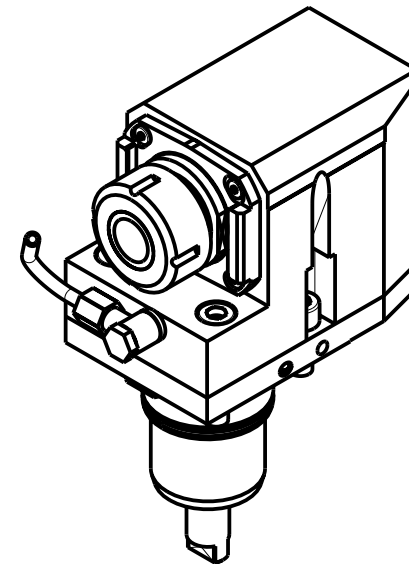
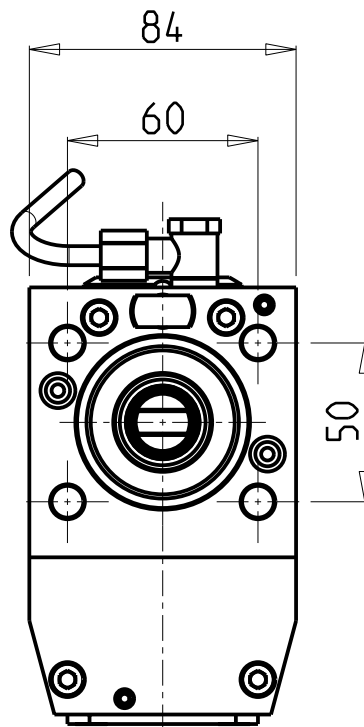
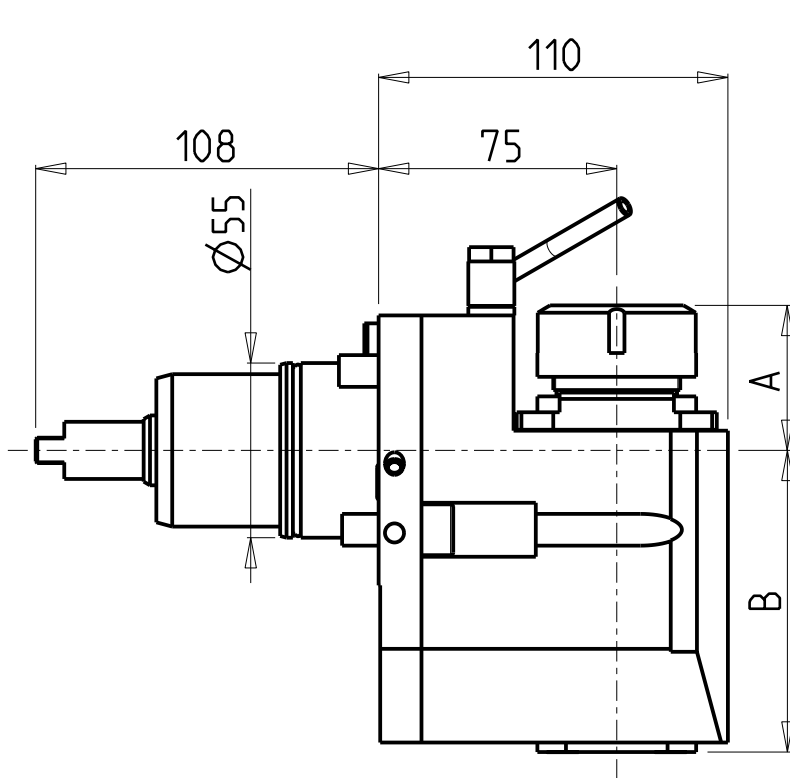

- Chiave inclusa
- Key included
- Schlüssel inbegriffen

Cod. MT	Mandrino Spindle Spindel	I	RPM	Coppia Max Max Torque Max Drehmoment	Reversibile lato mandrino/contromandrino Reversible sub/main spindle side Umkehrbare Spindel-seite/ Gegenspindel-seite	Lubr.interna Coolant through Innenkuehlung	Lubrificazione est. Ext. coolant Aussenkuehlung	A	B	CHIAVI NON INCLUSE Keys not included Schlüssel nicht einbegriffen	
NKM1080125	ER25	1:1	6000	50Nm	X	-	X	42.7	95	MNZ0410005	CHSTER25
NKM1080225	ER25	1:1	6000	50Nm	X	P=70bar	X	42.7	108.5	MNZ0410005	CHSTER25
NKM1080132	ER32	1:1	6000	50Nm	X	-	X	45.7	95	MNZ0410005	CHSTER32
NKM1080232	ER32	1:1	6000	50Nm	X	P=70bar	X	45.7	108.5	MNZ0410005	CHSTER32

NAKAMURA-TOME

WT250 - WT15011/25011 - WTW150 - WTS150 - SC150/200/250 - SUPER NTJX - NTY3 150/250

MODULO MOTORIZZATO ASSIALE ARRETRATO H=75mm

Axial rear-set driven tool H=75mm

Axial angetriebenes Werkzeug zurueckversetzt H=75mm

Subject to change without notice.

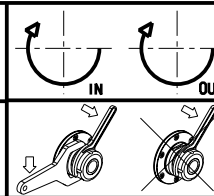

M.T. srl

Via Casino Albini 480
Tel. 0541/956034-957884
Fax 0541/956341
47842 S. GIOVANNI IN M. (RN)
e-mail: mtma@mtmarchetti.com
http://www.mtmarchetti.com

PRODUZIONE MODULI ROTANTI



PAGINA NKM180-2-10

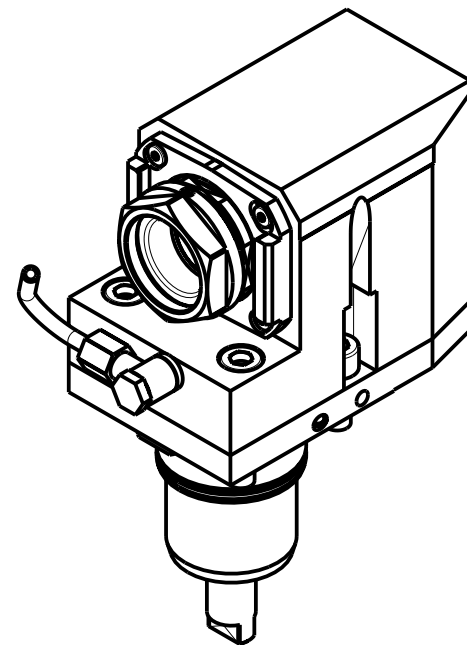
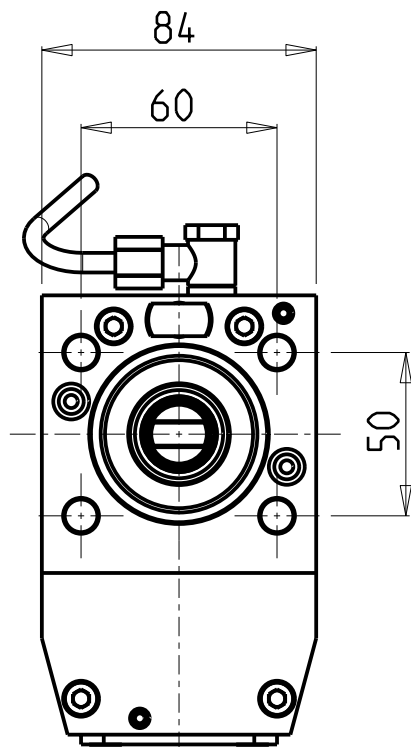
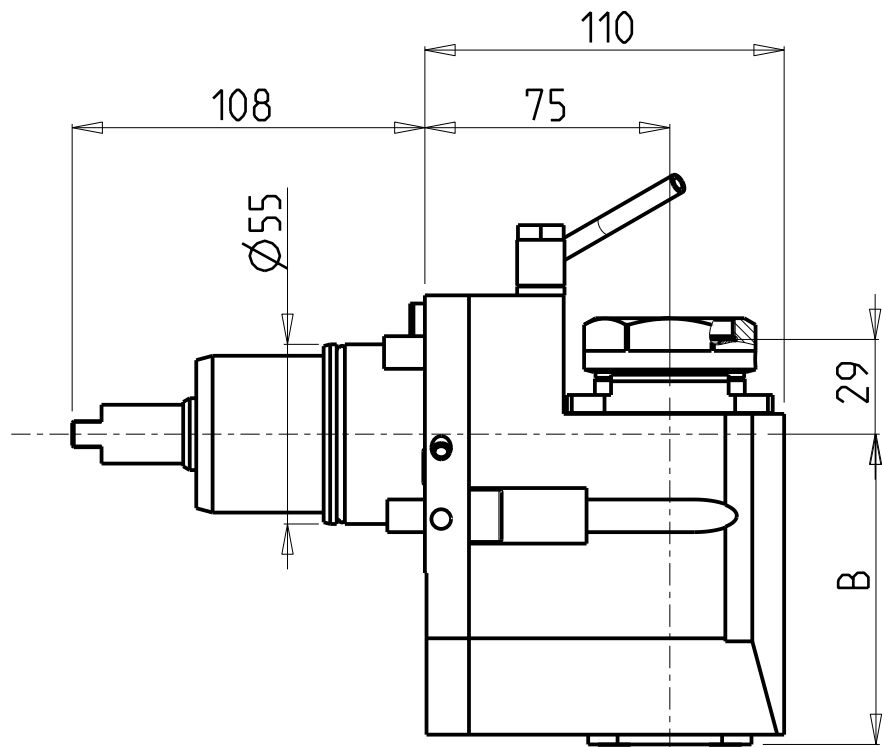

PER PORTAUTENSILI MODULARI MTSK-40 VEDI PAG. TBL300-1-40
 FOR MTSK-40 QUICK CHANGE TOOLHOLDERS CLAMPINGS SEE PAGE TBL300-1-40
 FUER MTSK-40 MODULARE WERKZEUGAUFNAHMEN SIEHE SEITE TBL300-1-40

Cod. MT	Mandrino Spindle Spindel	I	RPM	Coppia Max Max Torque Max Drehmoment	Reversibile lato mandrino/contromandrino Reversible sub/main spindle side Umkehrbare Spindel-seite/ Gegenspindel-seite	Lubrificazione int. Coolant through Innenkuehlung	Lubrificazione est. Ext. coolant Aussenkuehlung	B	CHIAVI NON INCLUDE Keys not included Schluessel nicht einbegriffen	
NKM1140140	MTSK-40	1:1	6000	50Nm	X	-	X	95	CHUB46	MNZ0410005 ■
NKM1140240	MTSK-40	1:1	6000	50Nm	X	P=70bar	X	108.5	CHUB46	MNZ0410005 ■

- Chiave inclusa
- Key included
- Schluessel inbegriffen

NAKAMURA-TOME
 WT250 - WT15011/25011 - WTW150 - WTS150 - SC150/200/250 - SUPER NTJX - NTY3 150/250

MODULO MOTORIZZATO ASSIALE ARRETRATO MTSK H=75mm
 Axial MTSK rear-set driven tool H=75mm
 Axial MTSK angetriebenes Werkzeug zurueckversetzt H=75mm

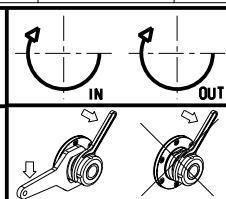

M.T. srl
 Via Casino Albini 480
 Tel. 0541/956034-957884
 Fax 0541/956341
 47842 S. GIOVANNI IN M. (RN)
 e-mail: mtma@mtmarchetti.com
 http://www.mtmarchetti.com

PRODUZIONE MODULI ROTANTI

 PAGINA NKM180-2-10-K

Subject to change without notice.

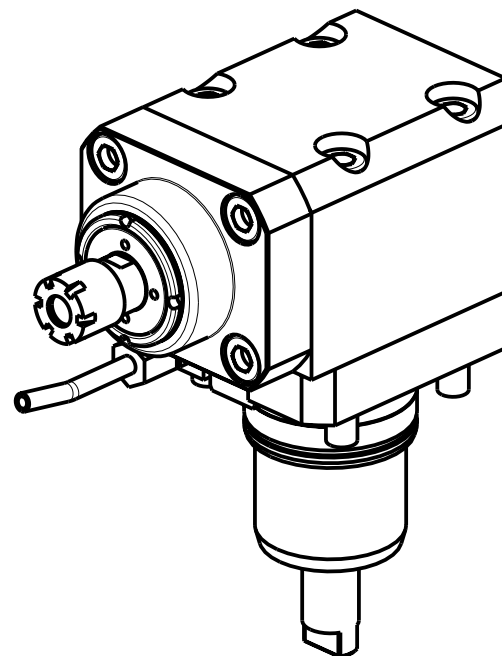
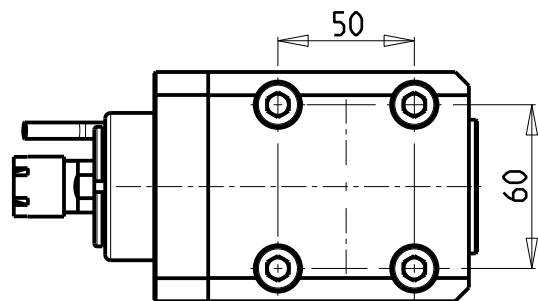
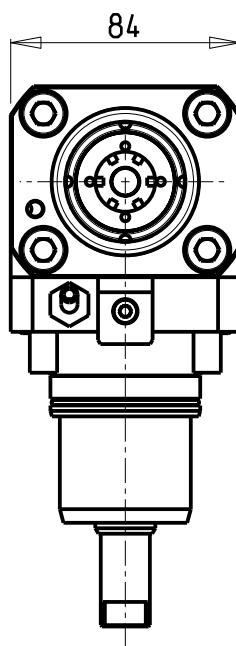
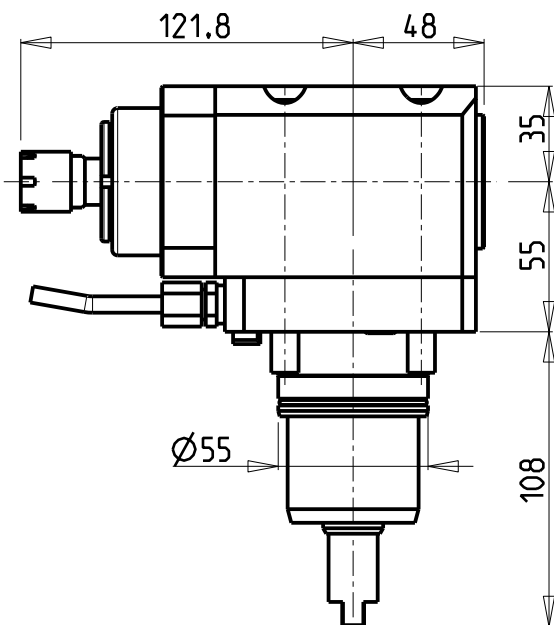

ATTENZIONE - ATTENTION - ACHTUNG

- Per lo smontaggio degli utensili utilizzare sempre la chiave di contrasto come indicato nel manuale d'uso.
- For disassembly of the tools use always the contrast key as mentioned in the user instructions.
- Fuer das Abmontieren der Werkzeuge immer den Gegenschlüssel benutzen wie in der Bedienungsanleitung erwaeht.

ATTENZIONE - ATTENTION - ACHTUNG

- PRIMA DI UTILIZZARE IL MOTORIZZATO CONSULTARE LE ISTRUZIONI ALLEGATE!
- BEFORE USING THE DRIVEN TOOL, PLEASE CHECK THE ENCLOSED INSTRUCTION SHEET!
- VOR DER BENUTZUNG DES ANGETRIEBENEN WERKZEUGES, DIE BEILIEGENDEN INSTRUKTIONEN DURCHLESEN!

Cod. MT	Mandrino Spindle Spindel	I	RPM	Coppia Max Max Torque Max Drehmoment	Reversibile lato mandrino/contromandrino Reversible sub/main spindle side Umkehrbare Spindel-seite/ Gegen-spindel-seite	Lubrificazione est. Ext. coolant Aussenkuehlung	CHIAVI INCLUDE Keys included Schluessel einbegriffen	
NKM0050016	ER16	1:3	18000	10Nm	X	X	CHUB17	CHMNER16

NAKAMURA-TOME

WT150/250 - WT15011/25011 - WTW150 - WTS150 - SUPER NTM3 - SUPER NTJ - SC150/200/250
 NTY3 150/250 - TW10M/MY/MM/MMY/MMYY-TW20M/MY/MM/MMY/MMYY 16 ST. - WY150/250 - AS200 15/24 ST.

MODULO MOTORIZZATO ASSIALE MOLTIPLICATO I=1:3 H=55mm

Axial geared-up I=1:3 driven tool H=55mm

Axial angetriebenes Werkzeug uebersetzt I=1:3 H=55mm

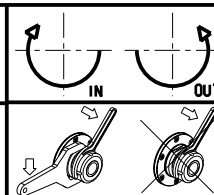

M.T. srl

Via Casino Albini 480
 Tel. 0541/956034-957884
 Fax 0541/956341
 47842 S. GIOVANNI IN M. (RN)
 e-mail: mtma@mtmarchetti.com
 http://www.mtmarchetti.com

PRODUZIONE MODULI ROTANTI



PAGINA NKM205-2-10

Subject to change without notice.

10/2018

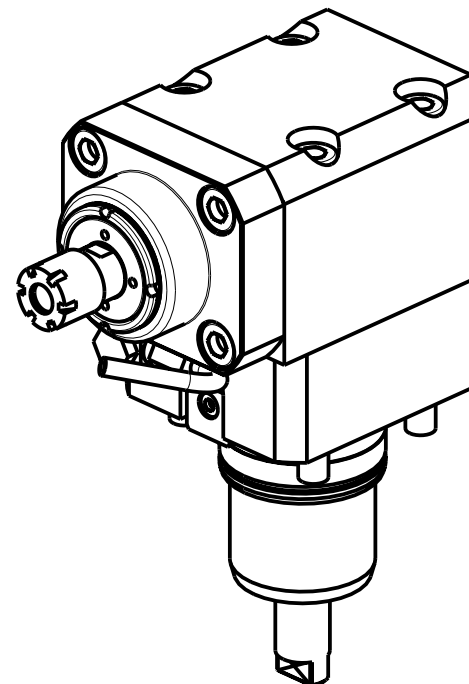
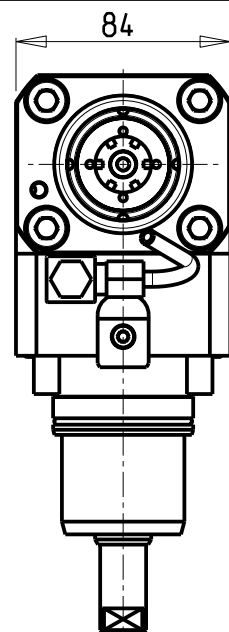
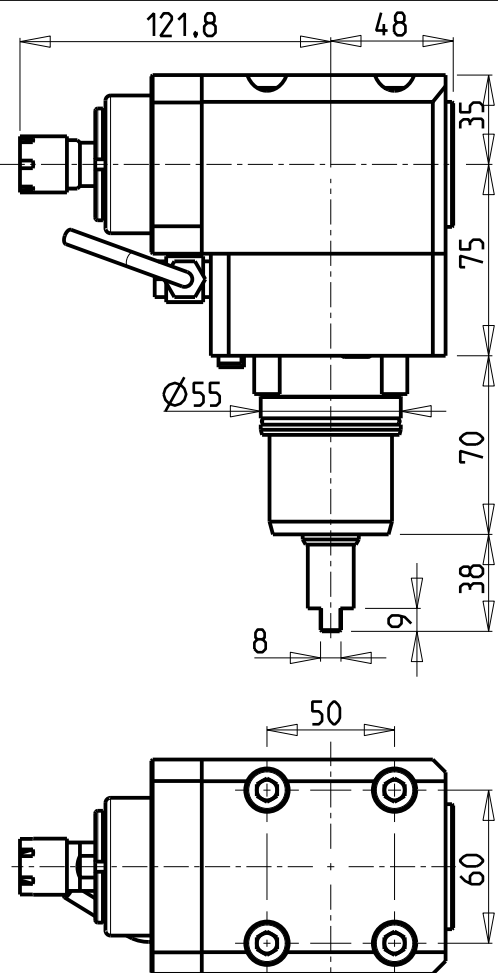

ATTENZIONE - ATTENTION - ACHTUNG

- Per lo smontaggio degli utensili utilizzare sempre la chiave di contrasto come indicato nel manuale d'uso.
- For disassembly of the tools use always the contrast key as mentioned in the user instructions.
- Fuer das Abmontieren der Werkzeuge immer den Gegenschlüssel benutzen wie in der Bedienungsanleitung erwaeht.

ATTENZIONE - ATTENTION - ACHTUNG

- PRIMA DI UTILIZZARE IL MOTORIZZATO CONSULTARE LE ISTRUZIONI ALLEGATE!
- BEFORE USING THE DRIVEN TOOL, PLEASE CHECK THE ENCLOSED INSTRUCTION SHEET!
- VOR DER BENUTZUNG DES ANGETRIEBENEN WERKZEUGES, DIE BEILIEGENDEN INSTRUKTIONEN DURCHLESEN!

Cod. MT	Mandrino Spindle Spindel	I	RPM	Coppia Max Max Torque Max Drehmoment	Reversibile lato mandrino/contromandrino Reversible sub/main spindle side Umkehrbare Spindelseite/Gegenspindelseite	Lubrificazione est. Ext. coolant Aussenkuehlung	CHIAVI INCLUSE Keys included Schluessel einbegriffen	
NKM0050216	ER16	1:3	18000	10Nm	X	X	CHUB17	CHMNER16

NAKAMURA-TOME

WT250 - WT150II/250II - WTW150 - WTS150 - SC150/200/250 - SUPER NTJX - NTY3 150/250

MODULO MOTORIZZATO ASSIALE MOLTIPLICATO I=1:3 H=75mm

Axial geared-up I=1:3 driven tool H=75mm

Axial angetriebenes Werkzeug uebersetzt I=1:3 H=75mm

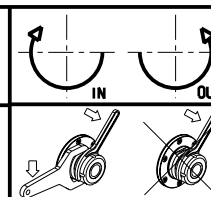

M.T. srl

Via Casino Albini 480
Tel. 0541/956034-957884
Fax 0541/956341
47842 S. GIOVANNI IN M. (RN)
e-mail: mtma@mtmarchetti.com
http://www.mtmarchetti.com

PRODUZIONE MODULI ROTANTI



PAGINA NKM205-2-20

Subject to change without notice.

10/2018

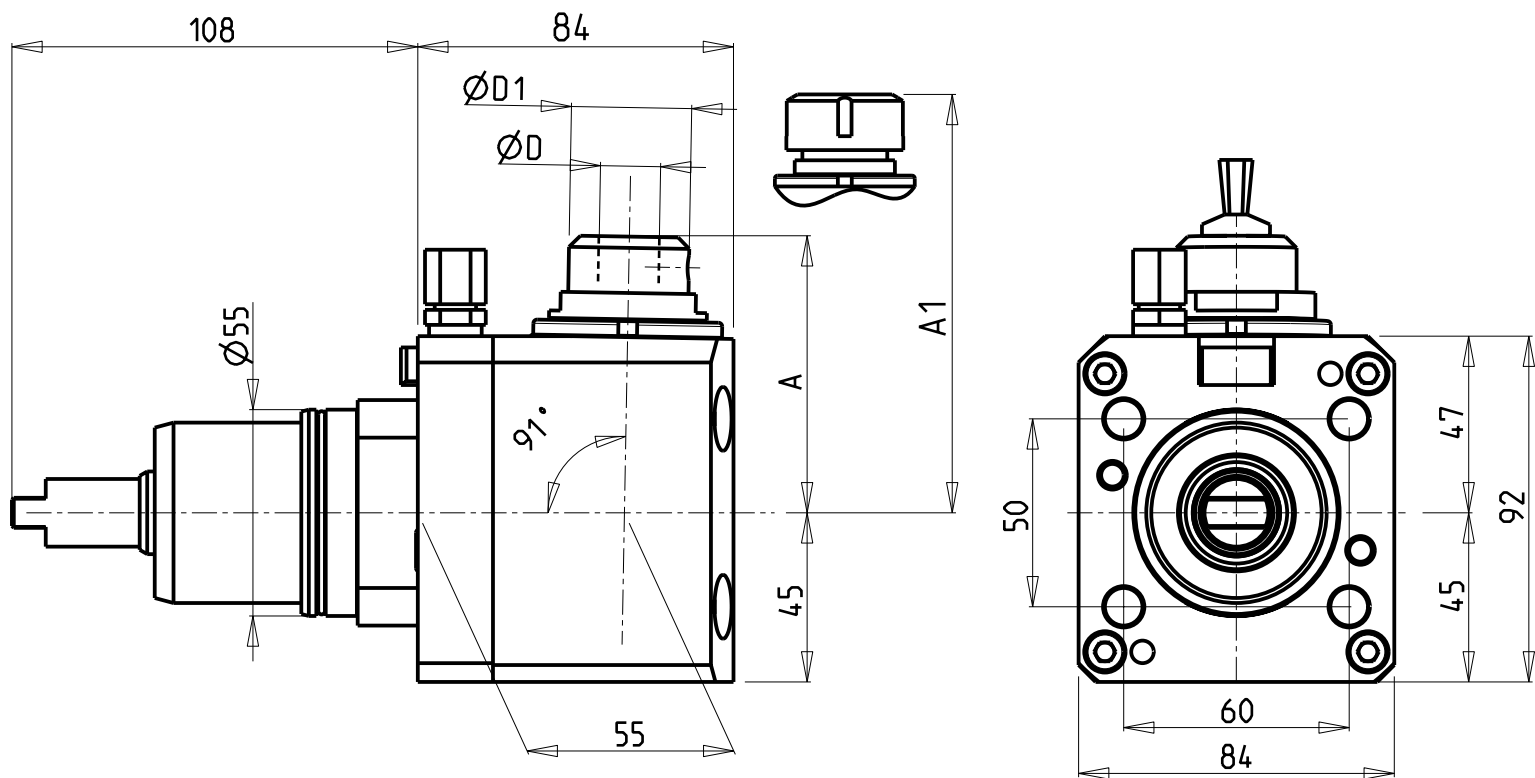

ATTENZIONE - ATTENTION - ACHTUNG

- Per lo smontaggio degli utensili utilizzare sempre la chiave di contrasto come indicato nel manuale d'uso.
- For disassembly of the tools use always the contrast key as mentioned in the user instructions.
- Fuer das Abmontieren der Werkzeuge immer den Gegenschlüssel benutzen wie in der Bedienungsanleitung erwaeht.

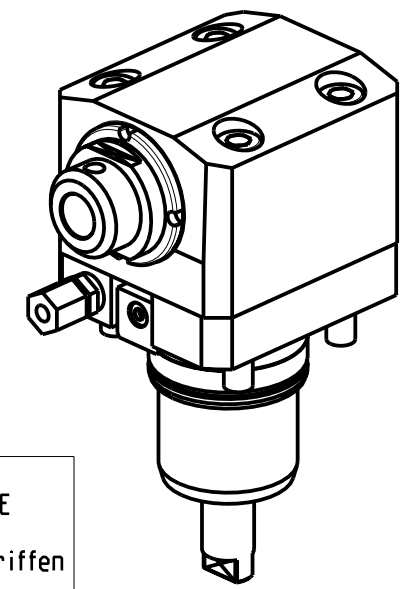

Cod. MT	Mandrino Spindel Spindel	I	RPM	Coppia Max Max Torque Max Drehmoment	Reversibile lato mandrino/contromandrino Reversible sub/main spindle side Umkehrbare Spindel-seite/ Gegenspindel-seite	Lubrificazione est. Ext. coolant Ausseukuehlung	A	A1	D	D1	CHIAVI NON INCLUSE Keys not included Schluessel nicht einbegriffen	
NKM0039125	ER25	1:1	6000	50Nm	X	X	-	80.44	-	-	CHUB36	CHSTER25
NKM0039108	WELDON 8	1:1	6000	50Nm	X	X	76.5	-	8	29	-	-
NKM0039110	WELDON 10	1:1	6000	50Nm	X	X	76.5	-	10	29	-	-
NKM0039112	WELDON 12	1:1	6000	50Nm	X	X	76.5	-	12	29	-	-
NKM0039116	WELDON 16	1:1	6000	50Nm	X	X	73.7	-	16	32	-	-

NAKAMURA-TOME
 WT150/250 - WT15011/25011 - WTW150 - WTS150 - SUPER NTM3 - SUPER NTJ - SC150/200/250
 NTY3 150/250 - TW10M/MY/MM/MMY/MMYY-TW20M/MY/MM/MMY/MMYY 16 ST. - WY 150/250 - AS200 15/24 ST.
MODULO MOTORIZZATO ASSIALE PER POLIGONATURA INTERNA H=55mm
 Axial driven tool for internal polygon-making H=55mm
 Axial angetriebenes Werkzeug fuer interne Facettierung H=55mm

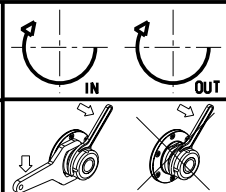

M.T. srl
 Via Casino Albini 480
 Tel. 0541/956034-957884
 Fax 0541/956341
 47842 S. GIOVANNI IN M. (RN)
 e-mail: mtma@mtmarchetti.com
 http://www.mtmarchetti.com

PRODUZIONE MODULI ROTANTI

PAGINA NKM230-2-10

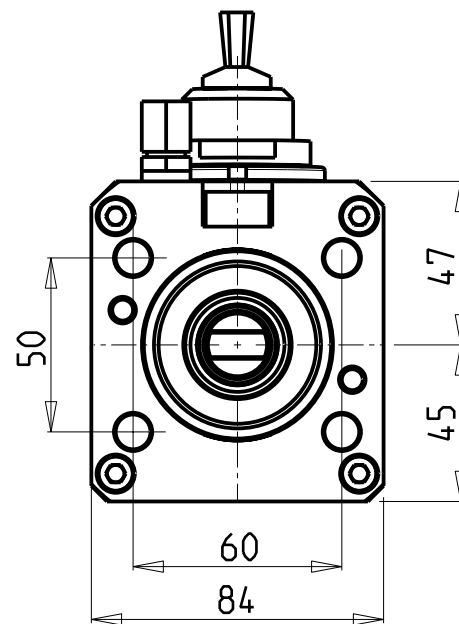
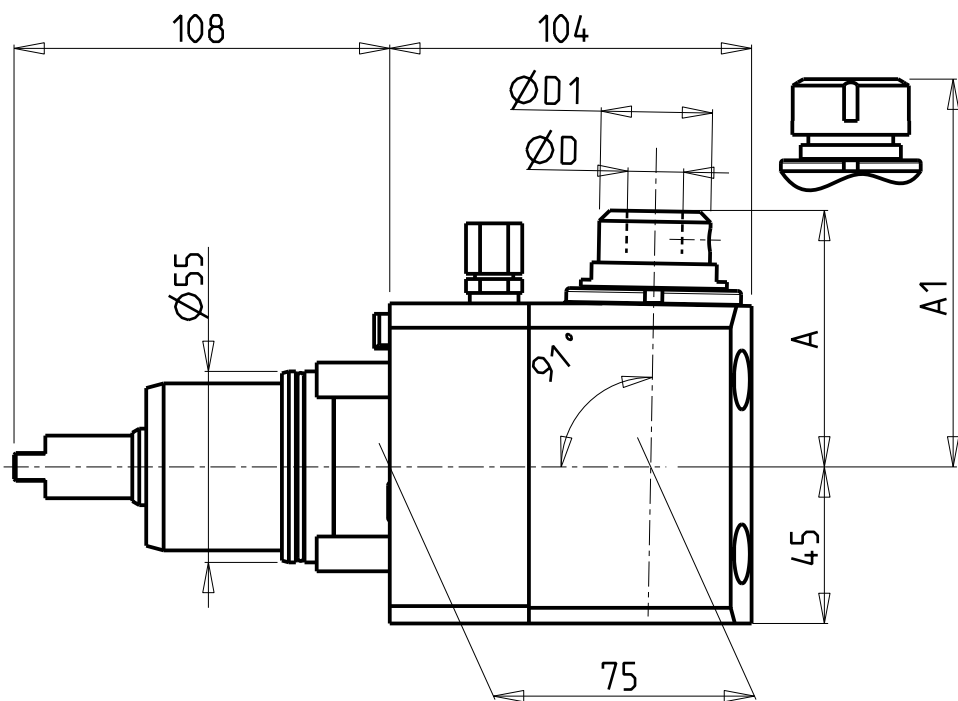
Subject to change without notice.

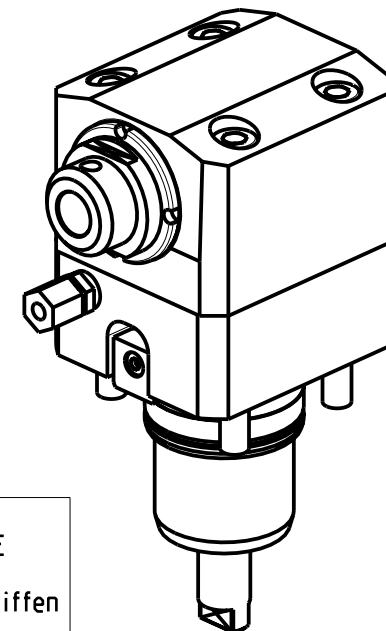

ATTENZIONE - ATTENTION - ACHTUNG

- Per lo smontaggio degli utensili utilizzare sempre la chiave di contrasto come indicato nel manuale d'uso.
- For disassembly of the tools use always the contrast key as mentioned in the user instructions.
- Fuer das Abmontieren der Werkzeuge immer den Gegenschlüssel benutzen wie in der Bedienungsanleitung erwäehnt.



Cod. MT	Mandrino Spindle Spindel	I	RPM	Coppia Max Max Torque Max Drehmoment	Reversibile lato mandrino/contromandrino Reversible sub/main spindle side Umkehrbare Spindel-seite/ Gegenspindel-seite	Lubrificazione est. Ext. coolant Aussenkuehlung	A	A1	D	D1	CHIAVI NON INCLUSE Keys not included Schluesel nicht einbegriffen	
NKM0069125	ER25	1:1	6000	50Nm	X	X	-	80.44	-	-	CHUB36	CHSTER25
NKM0069108	WELDON 8	1:1	6000	50Nm	X	X	76.5	-	8	29	-	-
NKM0069110	WELDON 10	1:1	6000	50Nm	X	X	76.5	-	10	29	-	-
NKM0069112	WELDON 12	1:1	6000	50Nm	X	X	76.5	-	12	29	-	-
NKM0069116	WELDON 16	1:1	6000	50Nm	X	X	73.7	-	16	32	-	-

NAKAMURA-TOME

WT250 - WT15011/25011 - WTW150 - WTS150 - SC150/200/250 - SUPER NTJX - NTY3 150/250

MODULO MOTORIZZATO ASSIALE PER POLIGONATURA INTERNA H=75mm

Axial driven tool for internal polygon-making H=75mm

Axial angetriebenes Werkzeug fuer interne Facettierung H=75mm

Subject to change without notice.

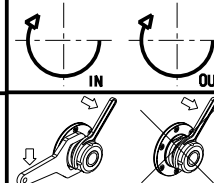

M.T. srl

Via Casino Albini 480
Tel. 0541/956034-957884
Fax 0541/956341
47842 S. GIOVANNI IN M. (RN)
e-mail: mtma@mtmarchetti.com
http://www.mtmarchetti.com

PRODUZIONE MODULI ROTANTI



PAGINA NKM230-2-20

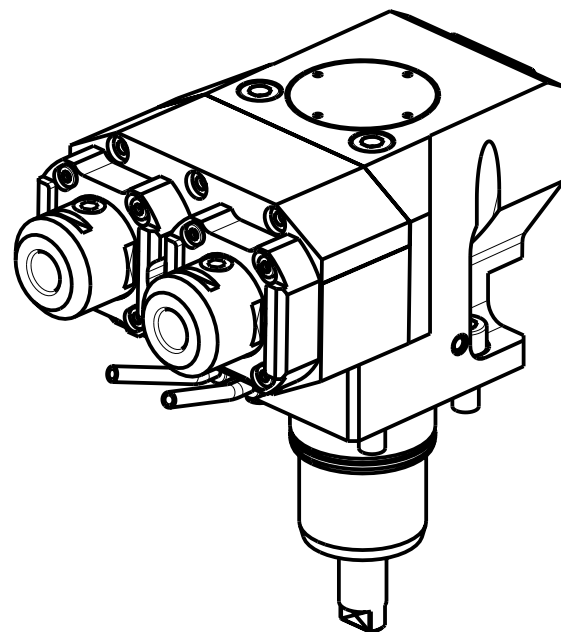
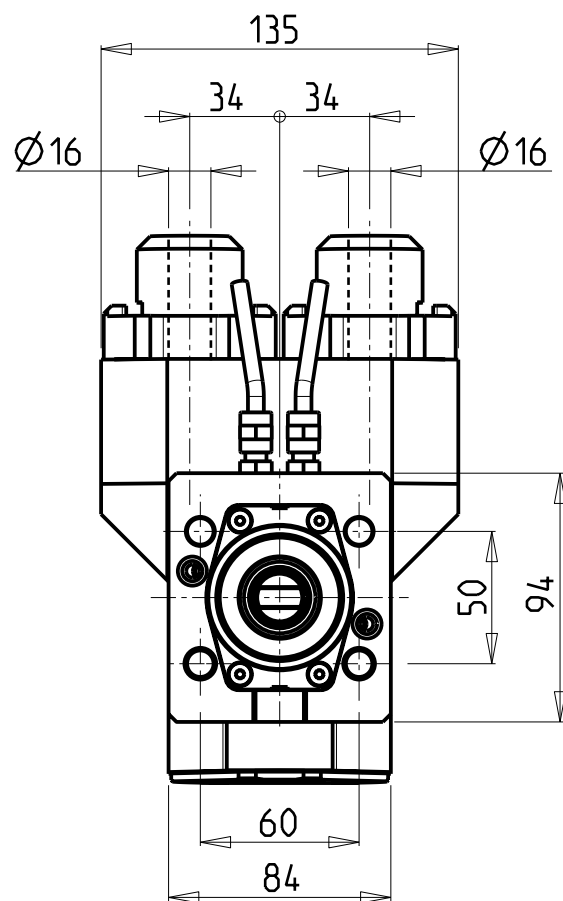
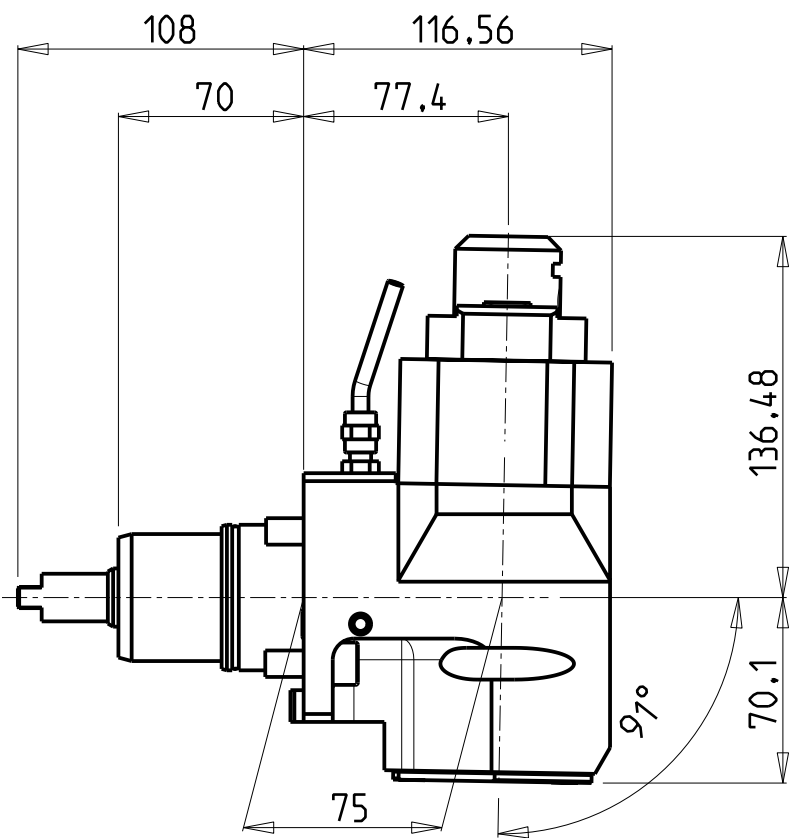

Cod. MT	Mandrino Spindle Spindel	I	RPM	Coppia Max Max Torque Max Drehmoment	Reversibile lato mandrino/contromandrino Reversible sub/main spindle side Umkehrbare Spindel-seite/ Gegenspindel-seite	Lubr.esterna Ext. coolant Aussenkuehlung	CHIAVI INCLUSE Keys included Schlüssel inbegriffen
NKM1250616	WELDON 16	1:1	6000	30Nm	X	X	SAU0070027

NAKAMURA-TOME

WT250 - WTW150 - WTS150 - SC150/200/250 - SUPER NTJX - AS200MY 15 ST.

MODULO MOTORIZZATO ASSIALE 2 USCITE IN Y PER POLIGONATURA INTERNA H=75mm

Axial single side twin head driven tool in Y for internal polygon-making H=75mm

Axial angetriebenes Werkzeug 2 Ausgänge in Y fuer interne Facettierung H=75mm

Subject to change without notice.

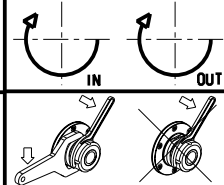

M.T. srl

Via Casino Albini 480
Tel. 0541/956034-957884
Fax 0541/956341

47842 S. GIOVANNI IN M. (RN)
e-mail: mtma@mtmarchetti.com
http://www.mtmarchetti.com

PRODUZIONE MODULI ROTANTI



PAGINA NKM233-2-10

ATTENZIONE - ATTENTION - ACHTUNG

- Per lo smontaggio degli utensili utilizzare sempre la chiave di contrasto come indicato nel manuale d'uso.
- For disassembly of the tools use always the contrast key as mentioned in the user instructions.
- Fuer das Abmontieren der Werkzeuge immer den Gegenschlüssel benutzen wie in der Bedienungsanleitung erwaeht.

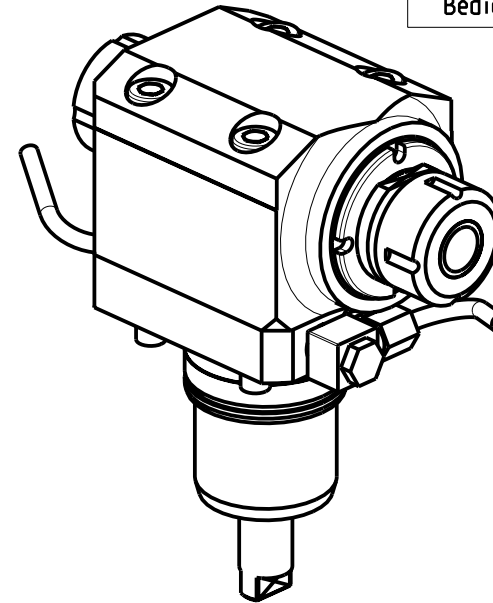
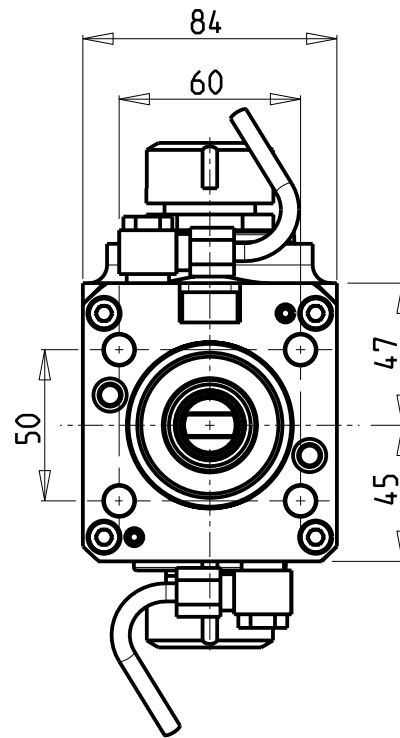
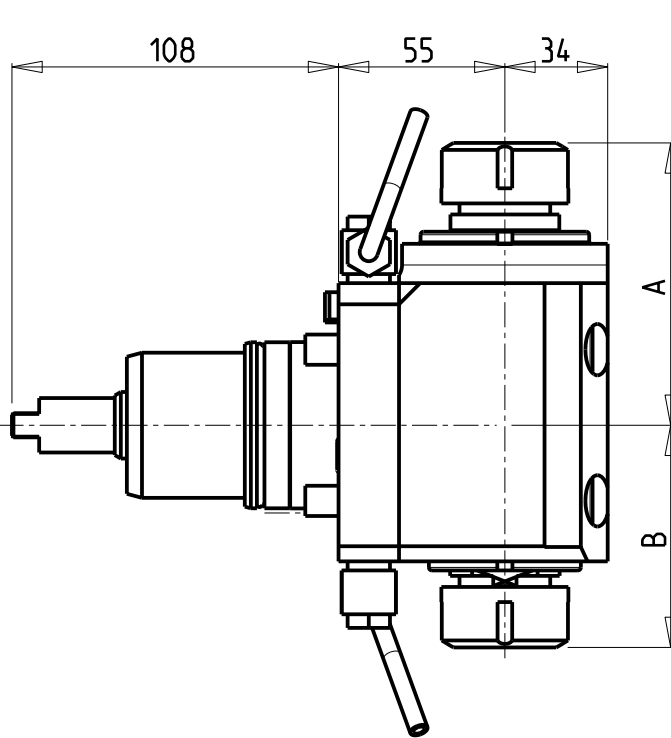

Cod. MT	Mandrino Spindle Spindel	I	RPM	Coppia Max Max Torque Max Drehmoment	Reversibile lato mandrino/contromandrino Reversible sub/main spindle side Umkehrbare Spindel-seite/ Gegenspindel-seite	Lubrificazione est. Ext. coolant Aussenkuehlung	A	B	CHIAVI NON INCLUSE Keys not included Schlüssel nicht einbegriffen	
NKM0492525	ER25+ER25	1:1	6000	50Nm	X	X	93.36	73.46	CHSTER25	CHUB36+CHUB29
NKM0493232	ER32+ER32	1:1	6000	50Nm	X	X	100.56	78.96	CHSTER32	CHUB36

NAKAMURA-TOME

WT150/250 - WT15011/25011 - WTW150 - WTS150 - SUPER NTM3 - SUPER NTJ - SC150/200/250
 NTY3 150/250 - TW10M/MY/MM/MMY/MMYY-TW20M/MY/MM/MMY/MMYY 16 ST. - WY 150/250 - AS200 15/24 ST.

MODULO MOTORIZZATO ASSIALE BISPORGENTE H=55mm

Axial opposite face twin driven tool H=55mm

Axial angetriebenes Werkzeug halb vorspringend H=55mm

Subject to change without notice.

M.T. srl

Via Casino Albini 480
 Tel. 0541/956034-957884
 Fax 0541/956341
 47842 S. GIOVANNI IN M. (RN)
 e-mail: mtma@mtmarchetti.com
 http://www.mtmarchetti.com

PRODUZIONE MODULI ROTANTI



PAGINA NKM240-2-10

ATTENZIONE - ATTENTION - ACHTUNG

- Per lo smontaggio degli utensili utilizzare sempre la chiave di contrasto come indicato nel manuale d'uso.
- For disassembly of the tools use always the contrast key as mentioned in the user instructions.
- Fuer das Abmontieren der Werkzeuge immer den Gegenschlüssel benutzen wie in der Bedienungsanleitung erwaeht.

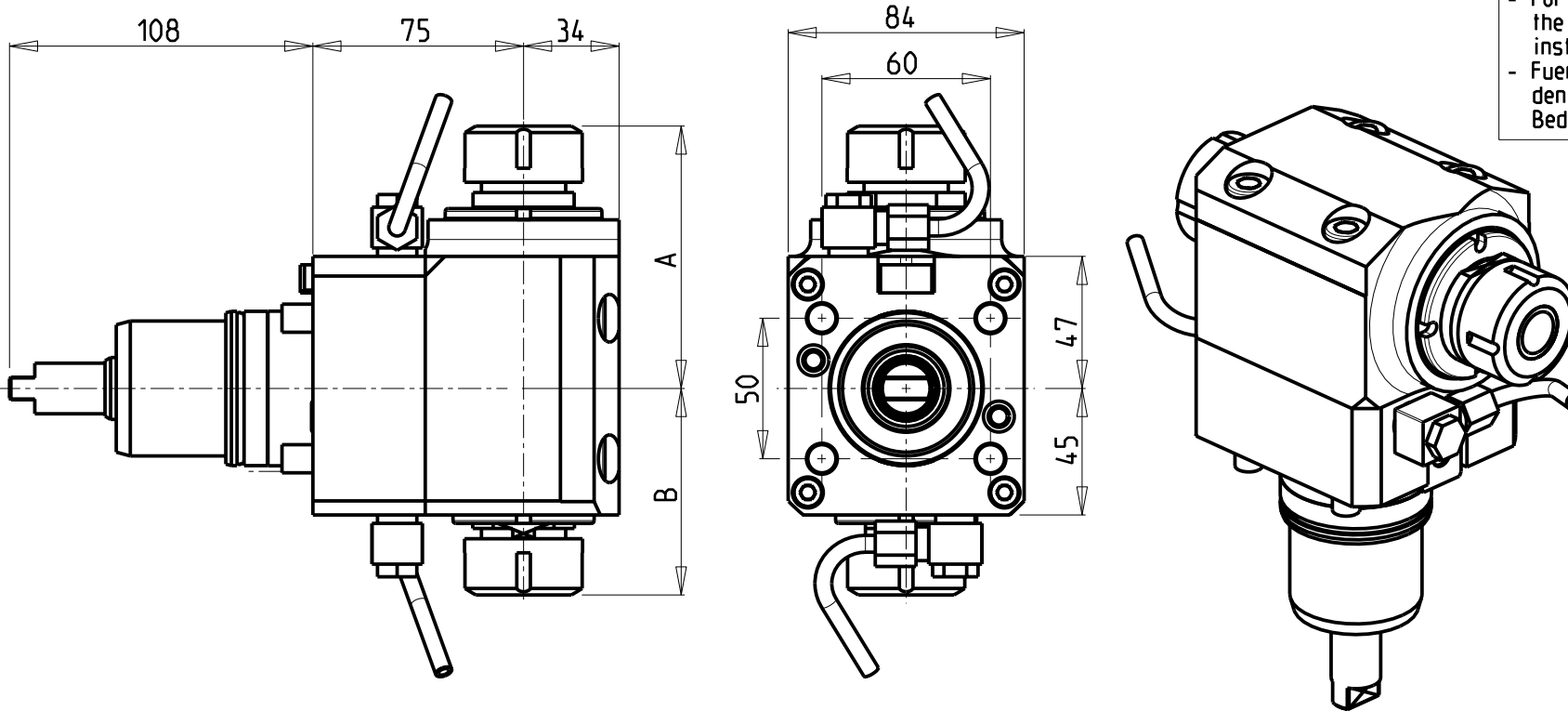

Cod. MT	Mandrino Spindle Spindel	I	RPM	Coppia Max Max Torque Max Drehmoment	Reversibile lato mandrino/contromandrino Reversible sub/main spindle side Umkehrbare Spindel-seite/ Gegenspindel-seite	Lubrificazione est. Ext. coolant Aussenkuehlung	A	B	CHIAVI NON INCLUSE Keys not included Schluessel nicht einbegriffen	
NKM0502525	ER25+ER25	1:1	6000	50Nm	X	X	93.36	73.46	CHSTER25	CHUB36+CHUB29
NKM0503232	ER32+ER32	1:1	6000	50Nm	X	X	100.56	78.96	CHSTER32	CHUB36

NAKAMURA-TOME

WT250 - WT15011/25011 - WTW150 - WTS150 - SC150/200/250 - SUPER NTJX - NTY3 150/250

MODULO MOTORIZZATO ASSIALE BISPORGENTE H=75mm

Axial opposite face twin driven tool H=75mm

Axial angetriebenes Werkzeug halb vorspringend H=75mm

Subject to change without notice.

M.T. srl

Via Casino Albini 480
Tel. 0541/956034-957884
Fax 0541/956341
47842 S. GIOVANNI IN M. (RN)
e-mail: mtma@mtmarchetti.com
http://www.mtmarchetti.com

PRODUZIONE MODULI ROTANTI



PAGINA NKM240-2-20

ATTENZIONE - ATTENTION - ACHTUNG

- Per lo smontaggio degli utensili utilizzare sempre la chiave di contrasto come indicato nel manuale d'uso.
- For disassembly of the tools use always the contrast key as mentioned in the user instructions.
- Fuer das Abmontieren der Werkzeuge immer den Gegenschlüssel benutzen wie in der Bedienungsanleitung erwaeht.

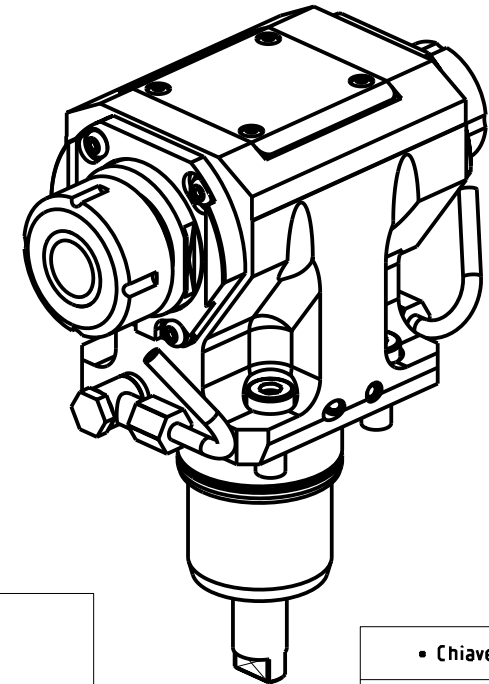
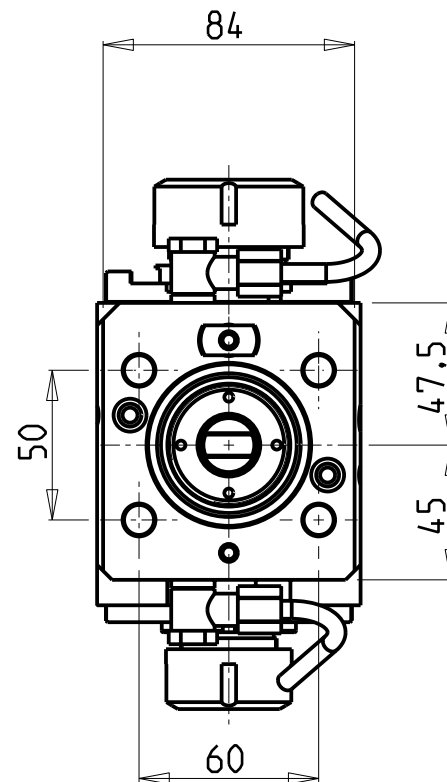
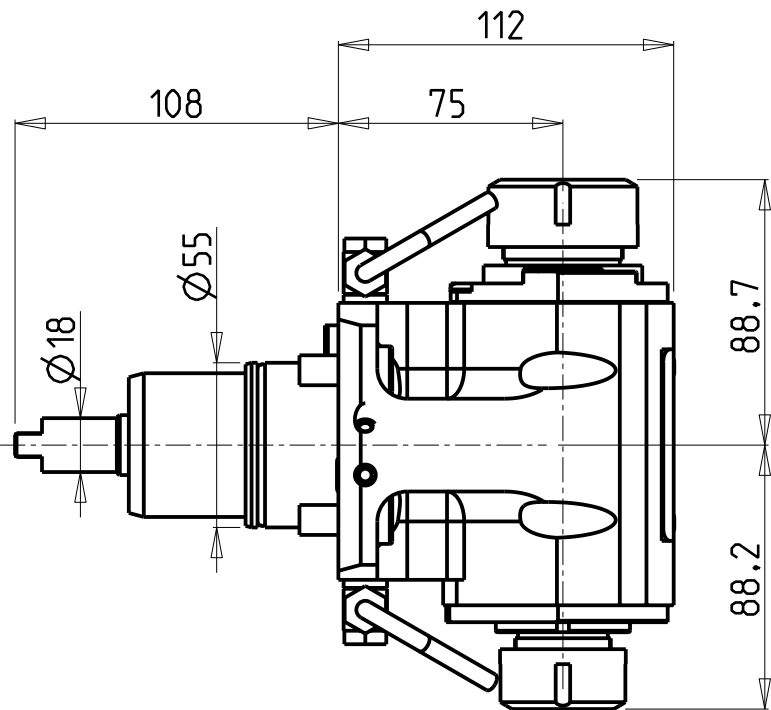

- Chiave inclusa
- Key included
- Schluessel inbegriffen

Cod. MT	Mandrino Spindle Spindel	I	RPM	Coppia Max Max Torque Max Drehmoment	Reversibile lato mandrino/contromandrino Reversible sub/main spindle side Umkehrbare Spindel-seite/ Gegenspindel-seite	Lubrificazione est. Ext. coolant Ausseinkuehlung	CHIAVI NON INCLUSE Keys not included Schluessel nicht einbegriffen		
NKM1403225	ER32+ER25	1:1	6000	50Nm	X	X	CHSTER32	CHSTER25	OKU0650004

NAKAMURA-TOME
 WT250 - WT15011/25011 - WTW150 - WTS150 - SC150/200/250 - SUPER NTJX - NTY3 150/250
 MODULO MOTORIZZATO ASSIALE BISPORGENTE H=75mm
 Axial opposite face twin driven tool H=75mm
 Axial angetriebenes Werkzeug halb vorspringend H=75mm

M.T. srl
 Via Casino Albini 480
 Tel. 0541/956034-957884
 Fax 0541/956341
 47842 S. GIOVANNI IN M. (RN)
 e-mail: mtma@mtmarchetti.com
 http://www.mtmarchetti.com

PRODUZIONE MODULI ROTANTI

 PAGINA NKM240-2-21

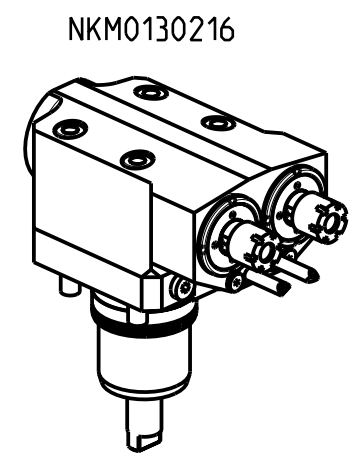
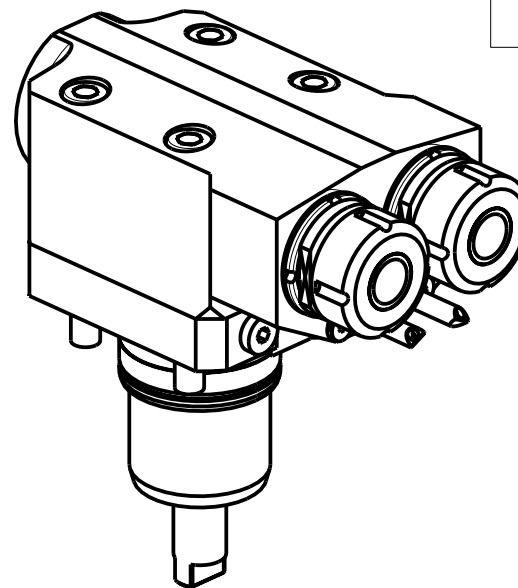
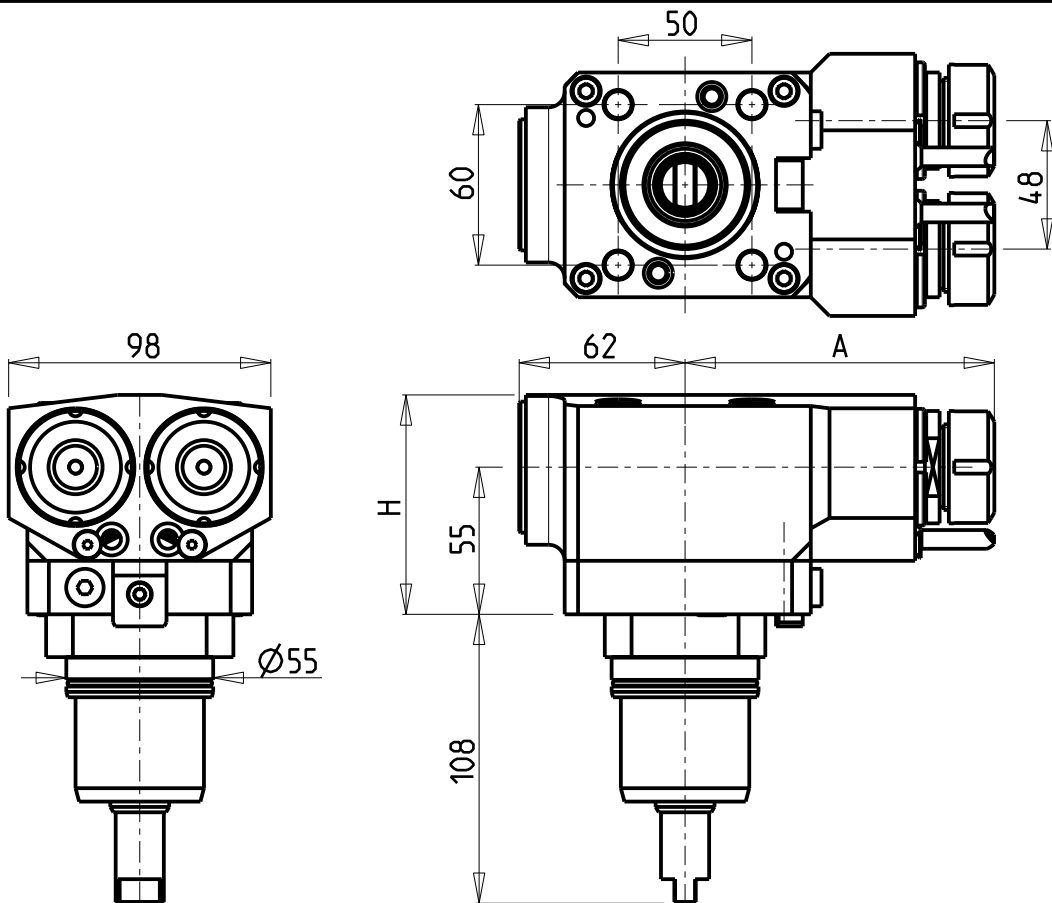
Subject to change without notice.



ATTENZIONE - ATTENTION - ACHTUNG

- Per lo smontaggio degli utensili utilizzare sempre la chiave di contrasto come indicato nel manuale d'uso.
- For disassembly of the tools use always the contrast key as mentioned in the user instructions.
- Fuer das Abmontieren der Werkzeuge immer den Gegenschlüssel benutzen wie in der Bedienungsanleitung erwaeht.

Cod. MT	Mandrino Spindle Spindel	I	RPM	Coppia Max Max Torque Max Drehmoment	Reversibile lato mandrino/contromandrino Reversible sub/main spindle side Umkehrbare Spindel-seite/ Gegenspindel-seite	Lubrificazione int. Coolant through Innenkuehlung	Lubrificazione est. Ext. coolant Aussenkuehlung	A	H	CHIAVI NON INCLUSE Keys not included Schluessel nicht einbegriffen	
NKM0130216	ER16	1:1	6000	30Nm	X	-	X	115.15	82	CHUB17	CHMNER16
NKM0130225	ER25	1:1	6000	30Nm	X	-	X	115.61	82	MNLO210007	CHSTER25
NKM0130425	ER25	1:1	6000	30Nm	X	P=70bar	X	128.11	87	MNLO210007	CHSTER25

NEW

NAKAMURA - TOME

WT150/250 - WT15011/25011 - WTW150 - WTS150 - SUPER NTM3 - SUPER NTJ - SC150/200/250
 NTY3 150/250 - TW10M/MY/MM/MMY/MMYY-TW20M/MY/MM/MMY/MMYY 16 ST. - WY 150/250 - AS200MY 15/24 ST.

MODULO MOTORIZZATO ASSIALE 2 USCITE IN Y H=55mm
 Axial single side twin head driven tool in Y H=55mm
 Axial angetriebenes Werkzeug 2 Ausgaenge in Y H=55mm

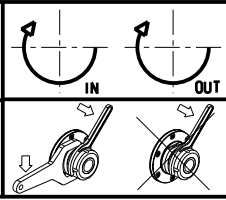

M.T. srl
 Via Casino Albini 480
 Tel. 0541/956034-957884
 Fax 0541/956341
 47842 S. GIOVANNI IN M. (RN)
 e-mail: mtma@mtmarchetti.com
 http://www.mtmarchetti.com

PRODUZIONE MODULI ROTANTI



PAGINA NKM260-2-10

Subject to change without notice.

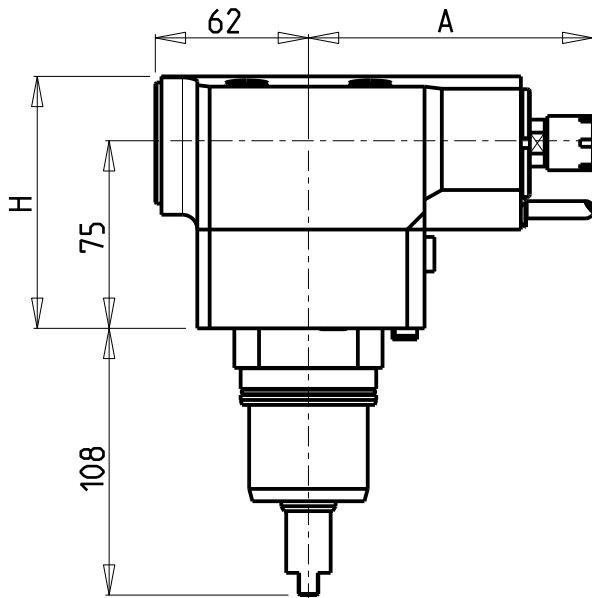
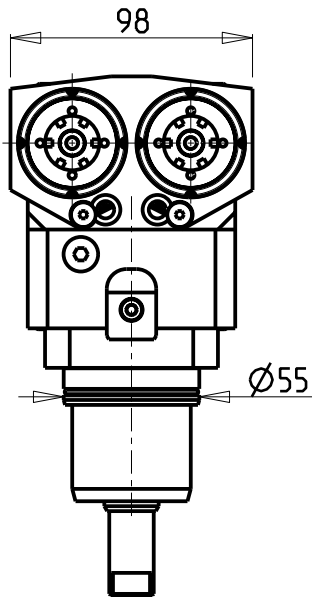
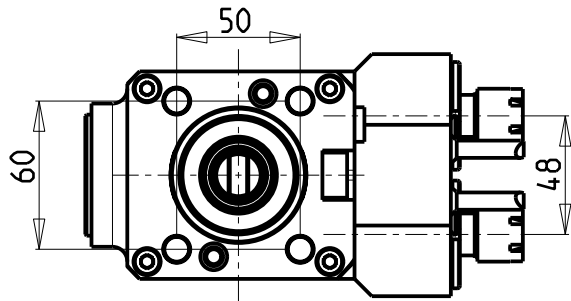

ATTENZIONE - ATTENTION - ACHTUNG

- VERIFICARE LE MISURE DI INGOMBRO PER POSSIBILE INTERFERENZA SU ALCUNI MODELLI DI MACCHINE
- Please check the overall sizes for possible interferences on some machine models
- Bitte überprüfen sie das ausmass um mögliche interferenzen auf einigen maschinen modellen zu vermeiden

ATTENZIONE - ATTENTION - ACHTUNG

- Per lo smontaggio degli utensili utilizzare sempre la chiave di contrasto come indicato nel manuale d'uso.
- For disassembly of the tools use always the contrast key as mentioned in the user instructions.
- Fuer das Abmontieren der Werkzeuge immer den Gegenschlüssel benutzen wie in der Bedienungsanleitung erwaehnt.

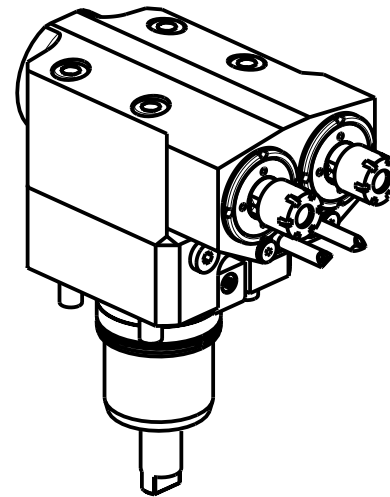

NKM0131225

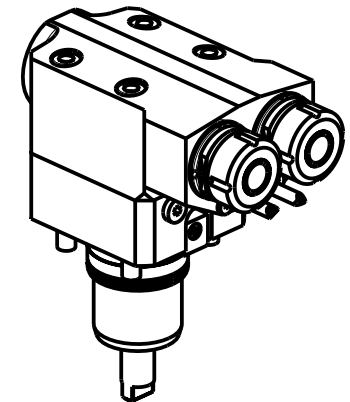

Cod. MT	Mandrino Spindle Spindel	I	RPM	Coppia Max Max Torque Max Drehmoment	Reversibile lato mandrino/contromandrino Reversible sub/main spindle side Umkehrbare Spindelsete/Gegenspindelsete	Lubrificazione int. Coolant through Innenkuehlung	Lubrificazione est. Ext. coolant Aussenkuehlung	A	H	CHIAVI NON INCLUSE Keys not included Schluessel nicht einbegriffen	
NKM0131216	ER16	1:1	6000	30Nm	X	-	X	115.15	102	CHUB17	CHMNER16
NKM0131225	ER25	1:1	6000	30Nm	X	-	X	115.61	102	MNLO210007	CHSTER25
NKM0131425	ER25	1:1	6000	30Nm	X	P=70bar	X	128.11	107	MNLO210007	CHSTER25

NEW

NAKAMURA-TOME

WT250 - WT15011/25011 - WTW150 - WTS150 - SC150/200/250 - SUPER NTJX - NTY3 150/250 - AS200MY 15 ST.

MODULO MOTORIZZATO ASSIALE 2 USCITE IN Y H=75mm
 Axial single side twin head driven tool in Y H=75mm
 Axial angetriebenes Werkzeug 2 Ausgaenge in Y H=75mm

Subject to change without notice.

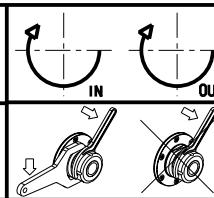

M.T. srl

Via Casino Albini 480
 Tel. 0541/956034-957884
 Fax 0541/956341
 47842 S. GIOVANNI IN M. (RN)
 e-mail: mtma@mtmarchetti.com
 http://www.mtmarchetti.com

PRODUZIONE MODULI ROTANTI



PAGINA NKM260-2-20

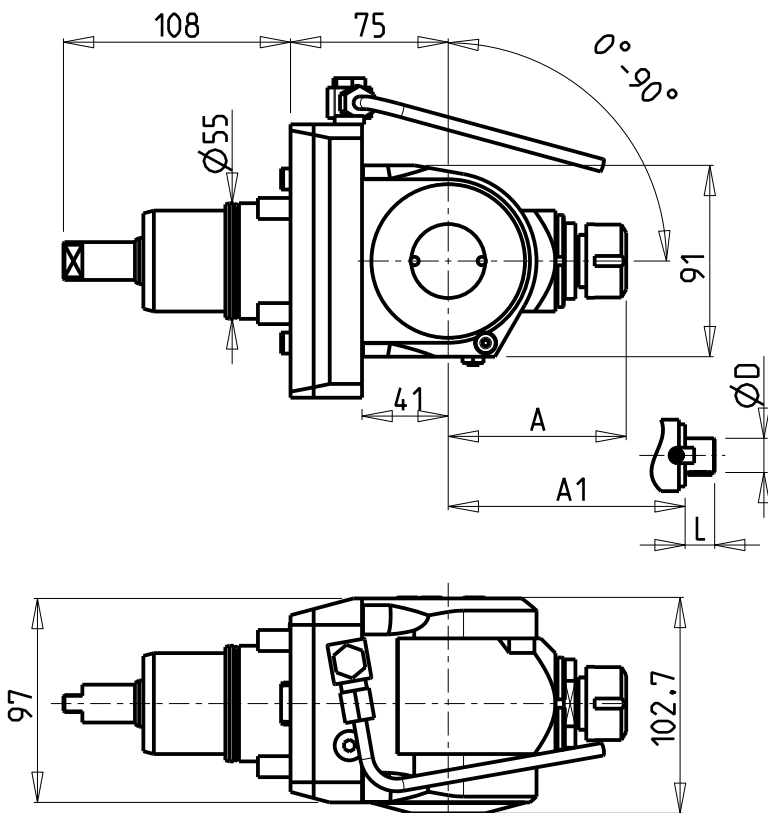

ATTENZIONE - ATTENTION - ACHTUNG

- FINO AD ESAURIMENTO SCORTE
- clearance sale
- solange vorrat

ATTENZIONE - ATTENTION - ACHTUNG

- Per lo smontaggio degli utensili utilizzare sempre la chiave di contrasto come indicato nel manuale d'uso.
- For disassembly of the tools use always the contrast key as mentioned in the user instructions.
- Fuer das Abmontieren der Werkzeuge immer den Gegenschlüssel benutzen wie in der Bedienungsanleitung erwäehnt.

ATTENZIONE - ATTENTION - ACHTUNG

- Verificare la tabella sottostante per possibile interferenza su alcuni modelli di macchine
- Please check the table below for possible interferences on some machine models
- Die untenstehende tabelle unbedingt auf eventuelle interferenzen auf eingen maschinen modellen überprüfen

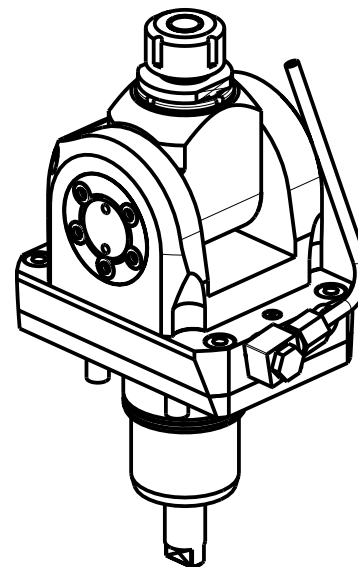

Cod. MT	Mandrino Spindle	I	RPM	Coppia Max Max Torque Max Drehmoment	Reversibile lato mandrino/contromandrino Reversible sub/main spindle side Umkehrbare Spindel-seite/ Gegenspindel-seite	Lubrificazione est. Ext. coolant Aussenkuehlung	A	A1	D	L	CHIAVI INCLUSE Keys included Schlüssel inbegriffen			
NKM0090020	ER20	1:1	6000	40Nm	X	X	84.16	-	-	-	CHSTER20	CHUB36	CHESL06	CHESL07
NKM0090025	ER25	1:1	6000	40Nm	X	X	85.66	-	-	-	CHSTER25	CHUB36	CHESL06	CHESL07
NKM0091617	Ø16x17	1:1	6000	40Nm	X	X	-	65	16	17	CH_VTCROCE_M08	CHUB36	CHESL06	CHESL07
NKM0092219	Ø22x19	1:1	6000	40Nm	X	X	-	66	22	19	CH_VTCROCE_M10	CHUB36	CHESL06	CHESL07
NKM0091905	Ø3/4"x3/4"	1:1	6000	40Nm	X	X	-	65	3/4"	3/4"	CH_VTCROCE_M08	CHUB36	CHESL06	CHESL07

NAKAMURA-TOME

WT150/250 - WT15011/25011 - WTW150 - WTS150 - SUPER NTM3 - SUPER NTJ - SUPER NTJX - SC150/200/250
 NTY3 150/250 - TW10M/MY/MM/MMY/MMYY-TW20M/MY/MM/MMY/MMYY 16 ST. - AS200 15/24 ST.

MODULO MOTORIZZATO ORIENTABILE 0-90°

0-90° adjustable angle driven tool

Angetriebenes Werkzeug schwenkbar 0-90°

Subject to change without notice.

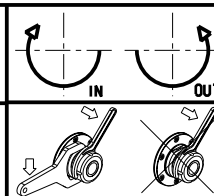

M.T. srl

Via Casino Albini 480
 Tel. 0541/956034-957884
 Fax 0541/956341
 47842 S. GIOVANNI IN M. (RN)
 e-mail: mtma@mtmarchetti.com
 http://www.mtmarchetti.com

PRODUZIONE MODULI ROTANTI



PAGINA NKM330-2-00

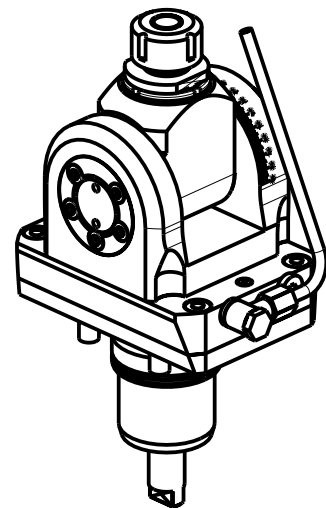
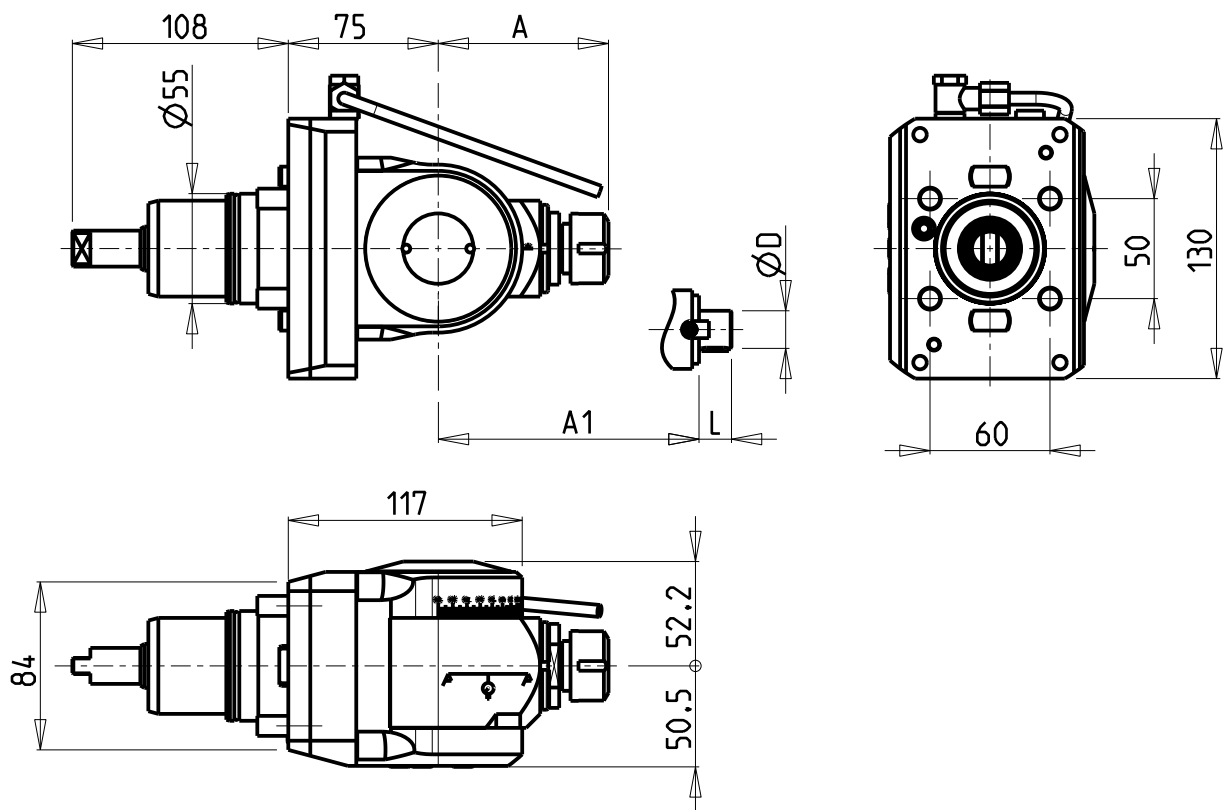

ATTENZIONE - ATTENTION - ACHTUNG

- Per lo smontaggio degli utensili utilizzare sempre la chiave di contrasto come indicato nel manuale d'uso.
- For disassembly of the tools use always the contrast key as mentioned in the user instructions.
- Fuer das Abmontieren der Werkzeuge immer den Gegenschlüssel benutzen wie in der Bedienungsanleitung erwaehtnt.

ATTENZIONE - ATTENTION - ACHTUNG

- Verificare la tabella sottostante per possibile interferenza su alcuni modelli di macchine
- Please check the table below for possible interferences on some machine models
- Die untenstehende tabelle unbedingt auf eventuelle interferenzen auf eingen maschinen modellen überprüfen

Cod. MT	Mandrino Spindle Spindel	I	RPM	Coppia Max Max Torque Max Drehmoment	Lubrificazione est. Ext. coolant Aussenkuehlung	A	A1	D	L	CHIAVI INCLUSE Keys included Schlüssel inbegriffen			
NKM1260120	ER20	1:1	6000	40Nm	X	85.16	-	-	-	CHSTER20	CHUB36	CHESL06	CHESL07
NKM1260125	ER25	1:1	6000	40Nm	X	86.16	-	-	-	CHSTER25	CHUB36	CHESL06	CHESL07
NKM1260516	Ø16x17	1:1	6000	40Nm	X	-	65	16	17	CH_VTCROCE_M08	CHUB36	CHESL06	CHESL07
NKM1260522	Ø22x19	1:1	6000	40Nm	X	-	66	22	19	CH_VTCROCE_M10	CHUB36	CHESL06	CHESL07
NKM1260519	Ø3/4"x3/4"	1:1	6000	40Nm	X	-	65	3/4"	3/4"	CH_VTCROCE_M08	CHUB36	CHESL06	CHESL07

NAKAMURA-TOME
 WT150/250 - WT15011/25011 - WTW150 - WTS150 - SUPER NTM3 - SUPER NTJ - SUPER NTJX - SC150/200/250
 NTY3 150/250 - TW10M/MY/MM/MMY/MMYY-TW20M/MY/MM/MMY/MMYY 16 ST. - AS200 15/24 ST.

MODULO MOTORIZZATO ORIENTABILE ±90°
 ±90° adjustable angle driven tool
 Angetriebenes Werkzeug schwenkbar ±90°

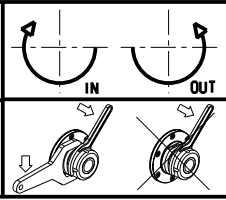

M.T. srl
 Via Casino Albini 480
 Tel. 0541/956034-957884
 Fax 0541/956341
 47842 S. GIOVANNI IN M. (RN)
 e-mail: mtma@mtmarchetti.com
 http://www.mtmarchetti.com

PRODUZIONE MODULI ROTANTI

 PAGINA NKM333-2-00

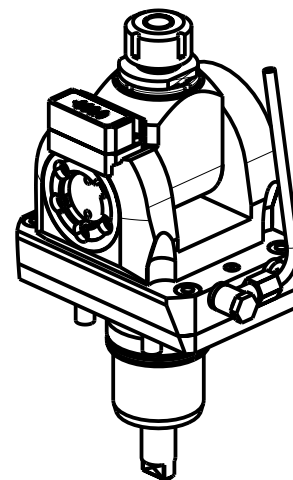
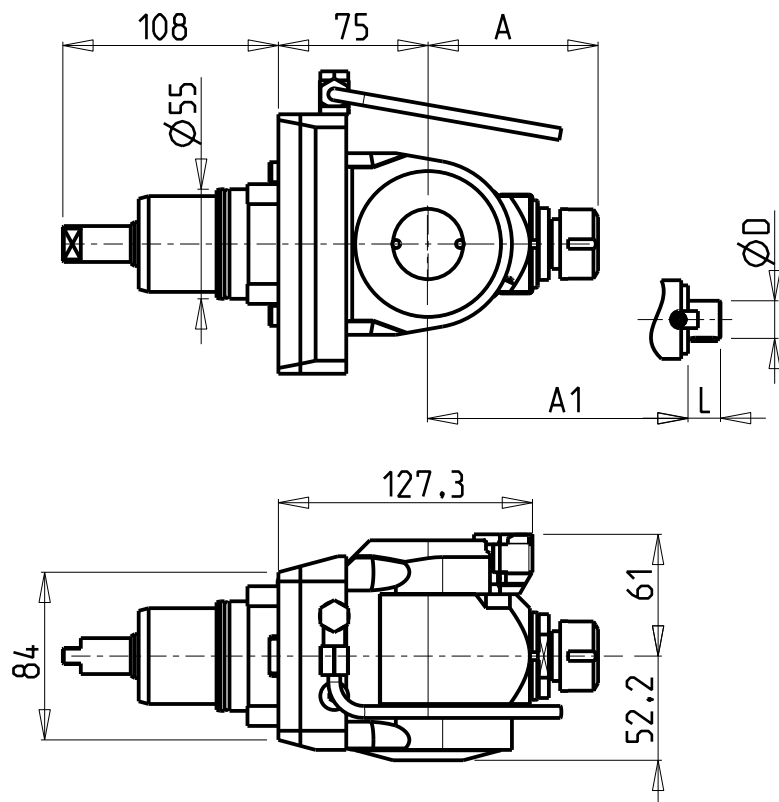
Subject to change without notice.



ATTENZIONE - ATTENTION - ACHTUNG

- Per lo smontaggio degli utensili utilizzare sempre la chiave di contrasto come indicato nel manuale d'uso.
- For disassembly of the tools use always the contrast key as mentioned in the user instructions.
- Fuer das Abmontieren der Werkzeuge immer den Gegenschlüssel benutzen wie in der Bedienungsanleitung erwaeht.

ATTENZIONE - ATTENTION - ACHTUNG

- Verificare la tabella sottostante per possibile interferenza su alcuni modelli di macchine
- Please check the table below for possible interferences on some machine models
- Die untenstehende tabelle unbedingt auf eventuelle interferenzen auf eingen maschinen modellen überprüfen

Cod. MT	Mandrino Spindel	I	RPM	Coppia Max Max Torque Max Drehmoment	Lubrificazione est. Ext. coolant Aussenkuehlung	A	A1	D	L	CHIAVI INCLUSE Keys included Schluessel inbegriffen			
NKM1220120	ER20	1:1	6000	40Nm	X	85.16	-	-	-	CHSTER20	CHUB36	CHESL06	CHESL07
NKM1220125	ER25	1:1	6000	40Nm	X	86.16	-	-	-	CHSTER25	CHUB36	CHESL06	CHESL07
NKM1220516	Ø16x17	1:1	6000	40Nm	X	-	65	16	17	CH_VTCROCE_M08	CHUB36	CHESL06	CHESL07
NKM1220522	Ø22x19	1:1	6000	40Nm	X	-	66	22	19	CH_VTCROCE_M10	CHUB36	CHESL06	CHESL07
NKM1220519	Ø3/4"x3/4"	1:1	6000	40Nm	X	-	65	3/4"	3/4"	CH_VTCROCE_M08	CHUB36	CHESL06	CHESL07

NAKAMURA-TOME

WT150/250 - WT15011/25011 - WTW150 - WTS150 - SUPER NTM3 - SUPER NTJ - SUPER NTJX - SC150/200/250
 NTY3 150/250 - TW10M/MY/MM/MMY/MYY - TW20M/MY/MM/MMY/MYY 16 ST. - AS200 15/24 ST.

MODULO MOTORIZZATO ORIENTABILE ±90° CON NONIO DIGITALE

±90° adjustable angle driven tool with digital display

Angetriebenes Werkzeug schwenkbar ±90° mit digital display

Subject to change without notice.

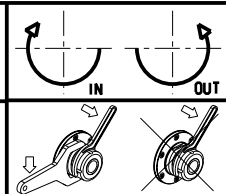

M.T. srl

Via Casino Albini 480
 Tel. 0541/956034-957884
 Fax 0541/956341

47842 S. GIOVANNI IN M. (RN)
 e-mail: mtma@mtmarchetti.com
 http://www.mtmarchetti.com

PRODUZIONE MODULI ROTANTI



PAGINA NKM333-2-01

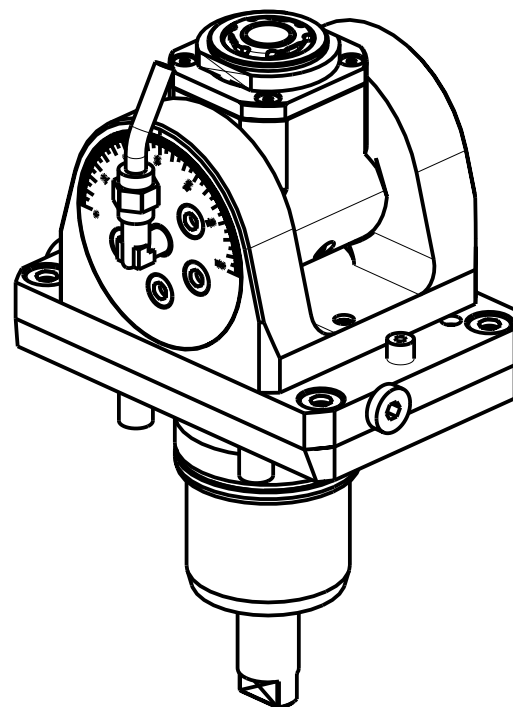
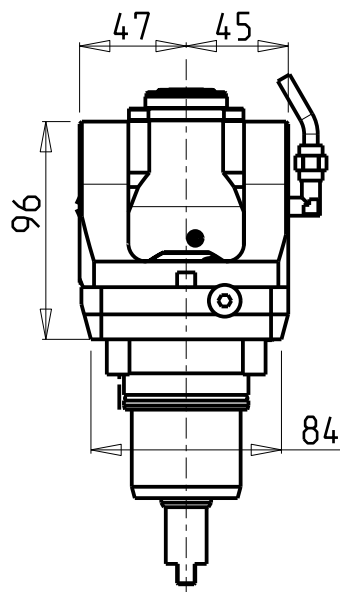
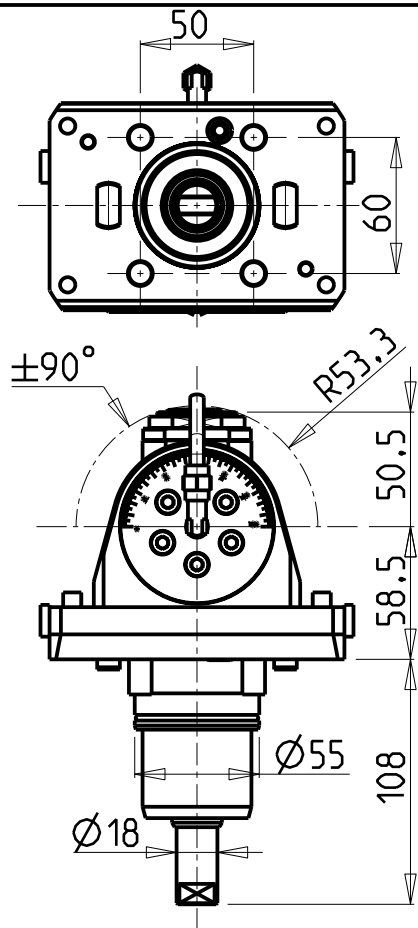

ATTENZIONE - ATTENTION - ACHTUNG

- Per lo smontaggio degli utensili utilizzare sempre la chiave di contrasto come indicato nel manuale d'uso.
- For disassembly of the tools use always the contrast key as mentioned in the user instructions.
- Fuer das Abmontieren der Werkzeuge immer den Gegenschlüssel benutzen wie in der Bedienungsanleitung erwaeht.

ATTENZIONE - ATTENTION - ACHTUNG

- Verificare la tabella sottostante per possibile interferenza su alcuni modelli di macchine
- Please check the table below for possible interferences on some machine models
- Die untenstehende tabelle unbedingt auf eventuelle interferenzen auf eingen maschinen modellen ueberpruefen

Cod. MT	Mandrino Spindle Spindel	I	RPM	Coppia Max Max Torque Max Drehmoment	Lubr.interna Coolant through Innenkuehlung	Lubrificazione est. Ext. coolant Aussenkuehlung	CHIAVI INCLUSE Keys included Schluessel inbegriffen				
							CHUB22	CHUB36	CHESL05	CHESL07	CHTAER20ZC
NKM0790120	ERA20	1:1	6000	30Nm		X	CHUB22	CHUB36	CHESL05	CHESL07	CHTAER20ZC
NKM0790220	ERA20	1:1	6000	30Nm	P=70bar	X	CHUB22	CHUB36	CHESL05	CHESL07	CHTAER20ZC

NAKAMURA-TOME

WT150/250 - WT15011/25011 - WTW150 - WTS150 - SUPER NTM3 - SUPER NTJ - SUPER NTJX - SC150/200/250
 NTY3 150/250 - TW10M/MY/MM/MMY/MMYY-TW20M/MY/MM/MMY/MMYY 16 ST. - WY150/250 - AS200 15/24 ST.

MODULO MOTORIZZATO ORIENTABILE ±90°

±90° adjustable angle driven tool

Angetriebenes Werkzeug schwenkbar ±90°

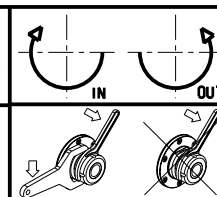

M.T. srl

Via Casino Albini 480
 Tel. 0541/956034-957884
 Fax 0541/956341
 47842 S. GIOVANNI IN M. (RN)
 e-mail: mtma@mtmarchetti.com
 http://www.mtmarchetti.com

PRODUZIONE MODULI ROTANTI



PAGINA NKM335-2-00

Subject to change without notice.

10/2018

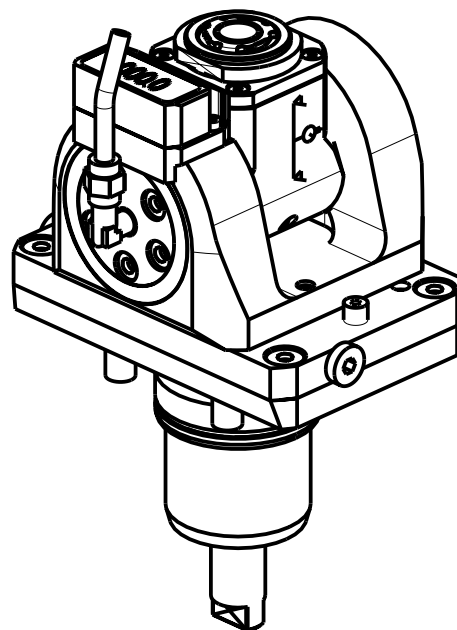
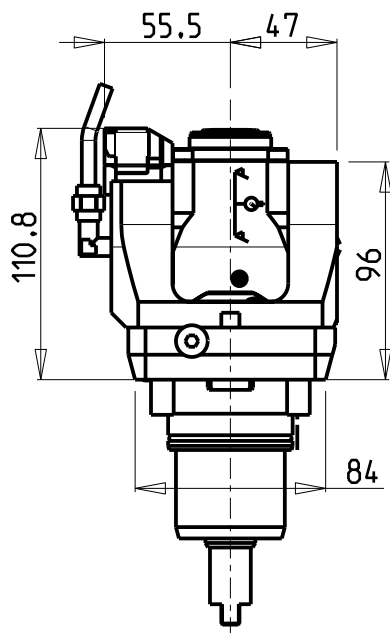
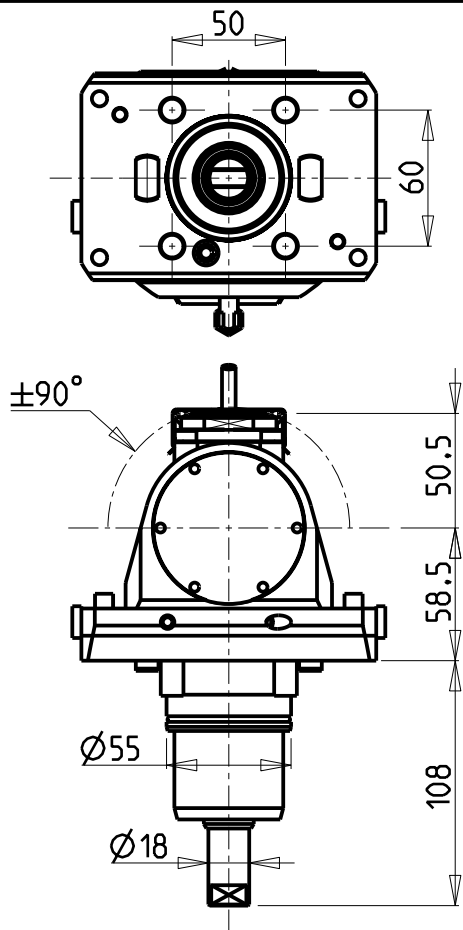

ATTENZIONE - ATTENTION - ACHTUNG

- Per lo smontaggio degli utensili utilizzare sempre la chiave di contrasto come indicato nel manuale d'uso.
- For disassembly of the tools use always the contrast key as mentioned in the user instructions.
- Fuer das Abmontieren der Werkzeuge immer den Gegenschlüssel benutzen wie in der Bedienungsanleitung erwaeht.

ATTENZIONE - ATTENTION - ACHTUNG

- Verificare la tabella sottostante per possibile interferenza su alcuni modelli di macchine
- Please check the table below for possible interferences on some machine models
- Die untenstehende tabelle unbedingt auf eventuelle interferenzen auf eingen maschinen modellen ueberpruefen

Cod. MT	Mandrino Spindle Spindel	I	RPM	Coppia Max Max Torque Max Drehmoment	Lubr.interna Coolant through Innenkuehlung	Lubrificazione est. Ext. coolant Aussenkuehlung	CHIAVI INCLUSE Keys included Schlüssel inbegriffen				
							CHUB22	CHUB36	CHESL05	CHESL07	CHTAER20ZC
NKM0795120	ERA20	1:1	6000	30Nm	-	X	CHUB22	CHUB36	CHESL05	CHESL07	CHTAER20ZC
NKM0795220	ERA20	1:1	6000	30Nm	P=70bar	X	CHUB22	CHUB36	CHESL05	CHESL07	CHTAER20ZC

NAKAMURA-TOME

WT150/250 - WT15011/25011 - WTW150 - WTS150 - SUPER NTM3 - SUPER NTJ - SUPER NTJX - SC150/200/250
 NTY3 150/250 - TW10M/MY/MM/MMY/MMYY-TW20M/MY/MM/MMY/MMYY 16 ST. - WY 150/250 - AS200 15/24 ST.

MODULO MOTORIZZATO ORIENTABILE ±90° CON NONIO DIGITALE

±90° adjustable angle driven tool with digital display

Angetriebenes Werkzeug schwenkbar ±90° mit digital display

Subject to change without notice.

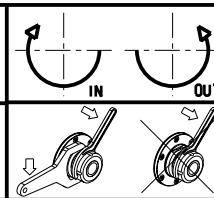

M.T. srl

Via Casino Albini 480
 Tel. 0541/956034-957884
 Fax 0541/956341

47842 S. GIOVANNI IN M. (RN)
 e-mail: mtma@mtmarchetti.com
 http://www.mtmarchetti.com

PRODUZIONE MODULI ROTANTI



PAGINA NKM335-2-01

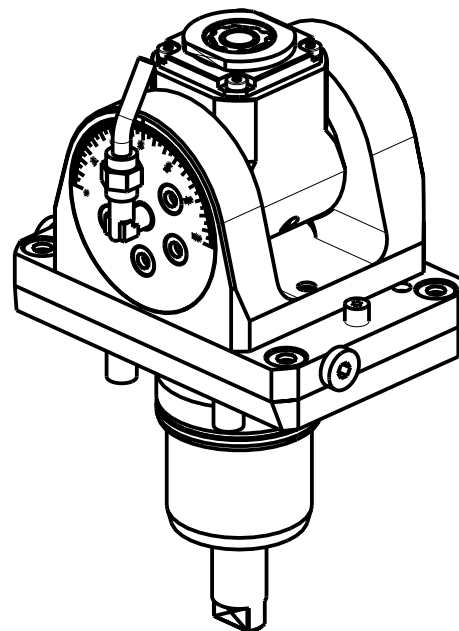
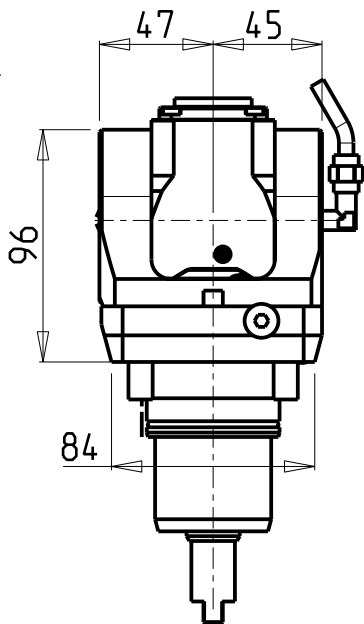
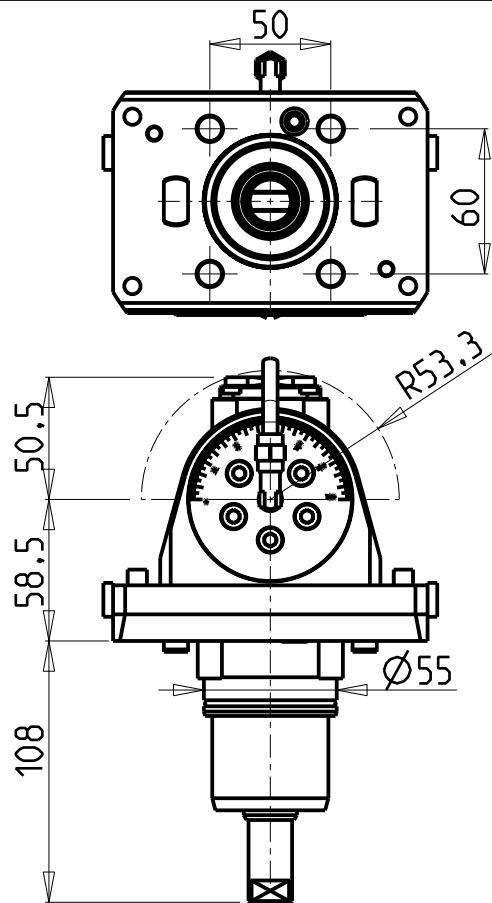

ATTENZIONE - ATTENTION - ACHTUNG

- Per lo smontaggio degli utensili utilizzare sempre la chiave di contrasto come indicato nel manuale d'uso.
- For disassembly of the tools use always the contrast key as mentioned in the user instructions.
- Fuer das Abmontieren der Werkzeuge immer den Gegenschlüssel benutzen wie in der Bedienungsanleitung erwaeht.

ATTENZIONE - ATTENTION - ACHTUNG

- Verificare la tabella sottostante per possibile interferenza su alcuni modelli di macchine
- Please check the table below for possible interferences on some machine models
- Die untenstehende tabelle unbedingt auf eventuelle interferenzen auf eingen maschinen modellen ueberpruefen

Cod. MT	Mandrino Spindle Spindel	I	RPM	Coppia Max Max Torque Max Drehmoment	Lubr.interna Coolant through Innenkuehlung	Lubrificazione est. Ext. coolant Aussenkuehlung	CHIAVI INCLUSE Keys included Schluessel inbegriffen				
							CHUB19_SP3	CHUB32	CHESL05	CHESL07	CHTAER16ZC
NKM0790316	ERA16	1:2	12000	8Nm		X	CHUB19_SP3	CHUB32	CHESL05	CHESL07	CHTAER16ZC
NKM0790416	ERA16	1:2	12000	8Nm	P=70bar	X	CHUB19_SP3	CHUB32	CHESL05	CHESL07	CHTAER16ZC

NAKAMURA-TOME

WT150/250 - WT15011/25011 - WTW150 - WTS150 - SUPER NTM3 - SUPER NTJ - SUPER NTJX - SC150/200/250
 NTY3 150/250 - TW10M/MY/MM/MMY/MYY-TW20M/MY/MM/MMY/MYY 16 ST. - WY 150/250 - AS200 15/24 ST.

MODULO MOTORIZZATO ORIENTABILE +/-90° MOLTIPLICATO I=1:2

+/-90° adjustable angle driven tool geared-up I=1:2

Angetriebenes Werkzeug schwenkbar +/-90° uebersetzt I=1:2

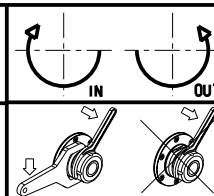

M.T. srl

Via Casino Albini 480
 Tel. 0541/956034-957884
 Fax 0541/956341
 47842 S. GIOVANNI IN M. (RN)
 e-mail: mtma@mtmarchetti.com
 http://www.mtmarchetti.com

PRODUZIONE MODULI ROTANTI



PAGINA NKM336-2-00

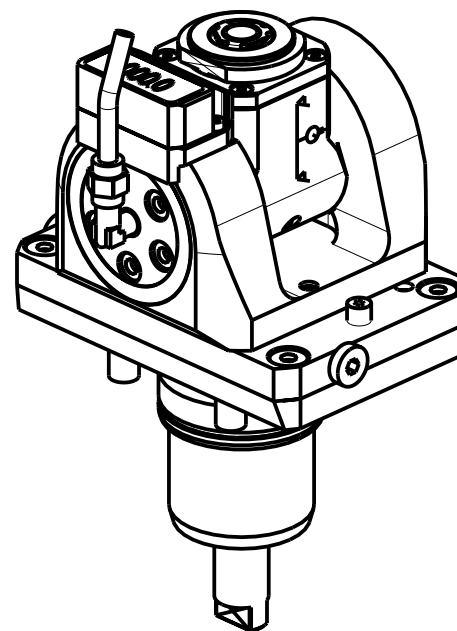
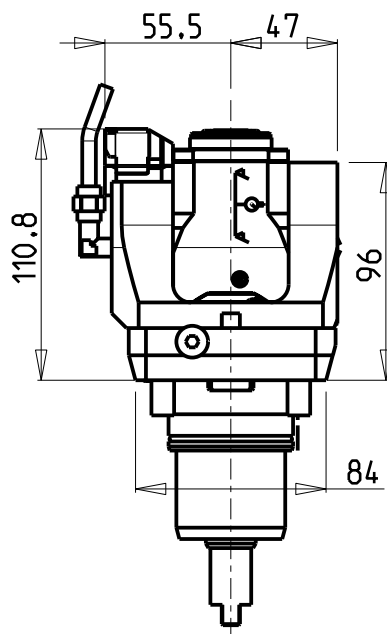
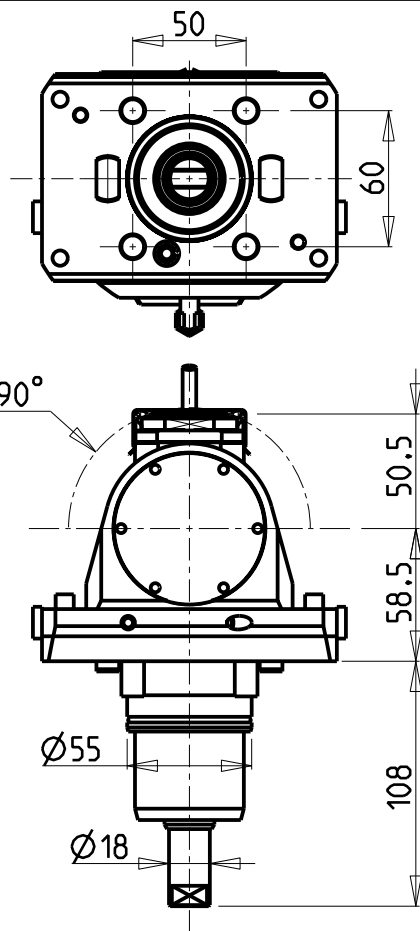

ATTENZIONE - ATTENTION - ACHTUNG

- Per lo smontaggio degli utensili utilizzare sempre la chiave di contrasto come indicato nel manuale d'uso.
- For disassembly of the tools use always the contrast key as mentioned in the user instructions.
- Fuer das Abmontieren der Werkzeuge immer den Gegenschlüssel benutzen wie in der Bedienungsanleitung erwaeht.

ATTENZIONE - ATTENTION - ACHTUNG

- Verificare la tabella sottostante per possibile interferenza su alcuni modelli di macchine
- Please check the table below for possible interferences on some machine models
- Die untenstehende tabelle unbedingt auf eventuelle interferenzen auf eingen maschinen modellen ueberpruefen

Cod. MT	Mandrino Spindle Spindel	i	RPM	Coppia Max Max Torque Max Drehmoment	Lubr.interna Coolant through Innenkuehlung	Lubrificazione est. Ext. coolant Aussenkuehlung	CHIAVI INCLUSE Keys included Schluessel inbegriffen				
							CHUB19_SP3	CHUB32	CHESL05	CHESL07	CHTAER16ZC
NKM0795316	ERA16	1:2	12000	8Nm	-	X	CHUB19_SP3	CHUB32	CHESL05	CHESL07	CHTAER16ZC
NKM0795416	ERA16	1:2	12000	8Nm	P=70bar	X	CHUB19_SP3	CHUB32	CHESL05	CHESL07	CHTAER16ZC

NAKAMURA-TOME

WT150/250 - WT15011/25011 - WTW150 - WTS150 - SUPER NTM3 - SUPER NTJ - SUPER NTJX - SC150/200/250
 NTY3 150/250 - TW10M/MY/MM/MMY/MMYY-TW20M/MY/MM/MMY/MMYY 16 ST. - WY150/250 - AS200 15/24 ST.

MODULO MOTORIZZATO ORIENTABILE +/-90° MOLTIPLICATO I=1:2 CON NONIO DIGITALE

+/-90° adjustable angle driven tool geared-up I=1:2 with digital display

Angetriebenes Werkzeug schwenkbar +/-90° uebersetzt I=1:2 mit digital display

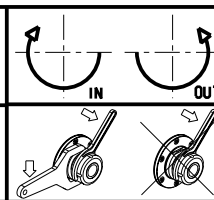

M.T. srl

Via Casino Albini 480
 Tel. 0541/956034-957884
 Fax 0541/956341

47842 S. GIOVANNI IN M. (RN)
 e-mail: mtma@mtmarchetti.com
 http://www.mtmarchetti.com

PRODUZIONE MODULI ROTANTI



PAGINA NKM336-2-01

Subject to change without notice.

10/2018

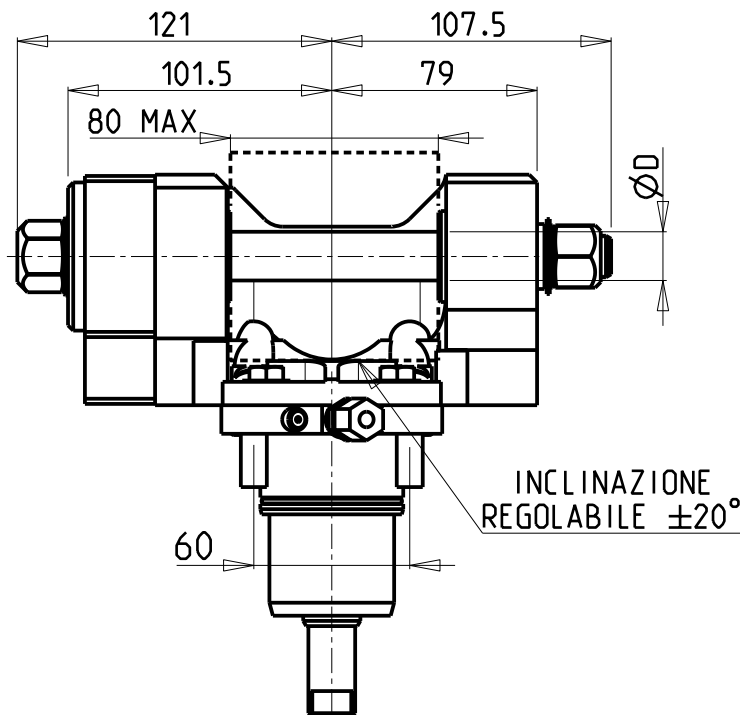
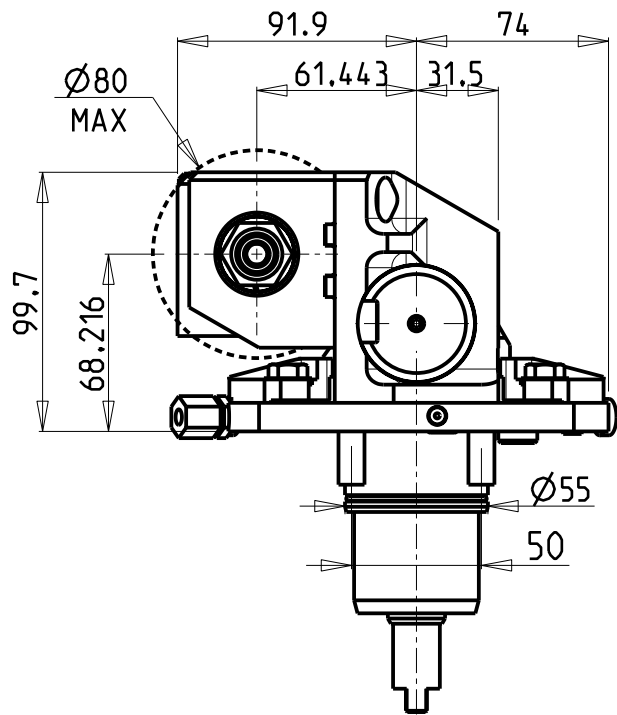

ATTENZIONE - ATTENTION - ACHTUNG

- Verificare la tabella sottostante per possibile interferenza su alcuni modelli di macchine
- Please check the table below for possible interferences on some machine models
- Die untenstehende tabelle unbedingt auf eventuelle interferenzen auf eingen maschinen modellen überprüfen

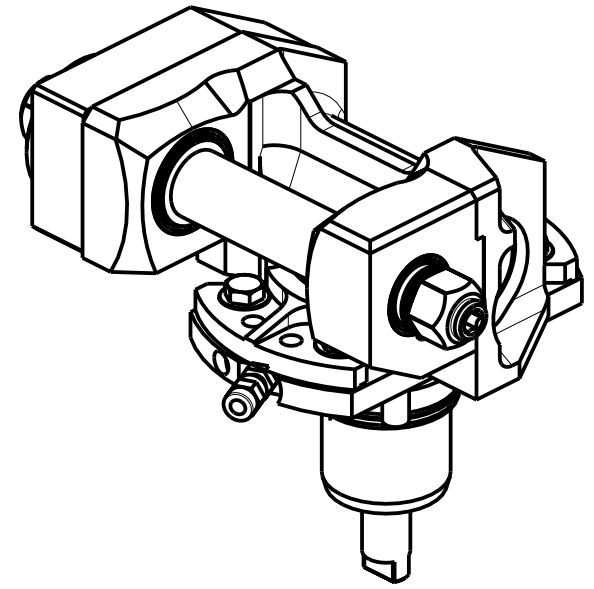

DOTAZIONI - SUPPLIED WITH - AUSSTATTUNG

mm / inch	- N°1 ALBERO + DISTANZIALI - N°1 SHAFT + SPACER - N°1 DORN + ABSTANDSSTUECK
-----------	---

PER ALBERI E DISTANZIALI VEDI PAG. TBL250-1-00
FOR SHAFT END SPACER SEE PAGE TBL250-1-00
FUER DORN UND ABSTANDSSTUECK SEITE TBL250-1-00

Cod. MT	I	RPM max	Coppia Max Max Torque Max Drehmoment	Reversibile lato mandrino/contromandrino Reversible sub/main spindle side Umkehrbare Spindel-seite/ Gegenspindel-seite	Lubrificazione est. Ext. coolant Aussenkuehlung	D (mm)	D (Inch)	CHIAVI INCLUSE Keys included Schluessel inbegriffen			
								CHUB13	CHUB24	CHESL08	CHESL07
NKM0081100	1:1	6000	60Nm	X	X	16-22-27-32	3/4"-1"-1 1/4"	CHUB13	CHUB24	CHESL08	CHESL07
NKM0082100	2:1	3000	80Nm	X	X	16-22-27-32	3/4"-1"-1 1/4"	CHUB13	CHUB24	CHESL08	CHESL07

NAKAMURA-TOME

WT150/250 - WT15011/25011 - WTW150 - WTS150 - SUPER NTM3 - SUPER NTJ - SUPER NTJX - SC150/200/250
NTY3 150/250 - TW10M/MY/MM/MMY/MMYY-TW20M/MY/MM/MMY/MMYY 16 ST. - WY 150/250 - AS200 15/24 ST.

MODULO MOTORIZZATO PORTACREATORE

Driven gear hobber
Angetriebenes Zahnradwalzfraes-Werkzeug

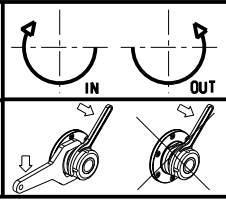

M.T. srl
Via Casino Albini 480
Tel. 0541/956034-957884
Fax 0541/956341
47842 S. GIOVANNI IN M. (RN)
e-mail: mtma@mtmarchetti.com
http://www.mtmarchetti.com

PRODUZIONE MODULI ROTANTI



PAGINA NKM340-2-00

Subject to change without notice.

ATTENZIONE - ATTENTION - ACHTUNG

- VERIFICARE LE MISURE DI INGOMBRO PER POSSIBILE INTERFERENZA SU ALCUNI MODELLI DI MACCHINE
- Please check the overall sizes for possible interferences on some machine models
- Bitte überprüfen sie das ausmass um mögliche interferenzen auf einigen maschinen modellen zu vermeiden

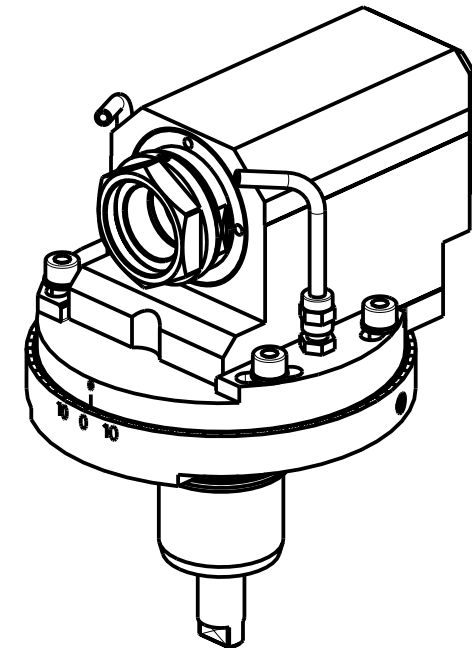
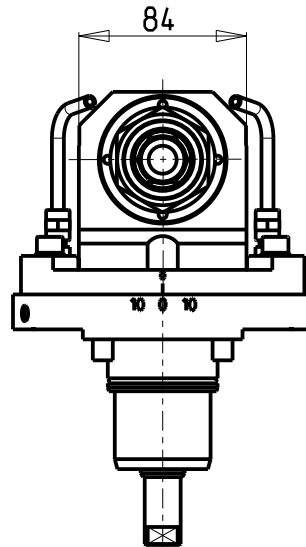
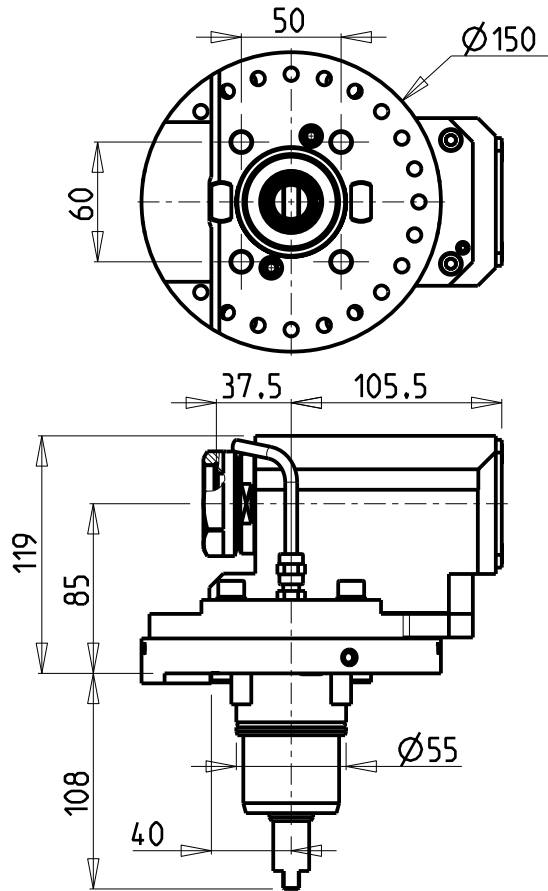

PER PORTAUTENSILI MODULARI MTSK-40 VEDI PAG. TBL300-1-40
 FOR MTSK-40 QUICK CHANGE TOOLHOLDERS CLAMPINGS SEE PAGE TBL300-1-40
 FUER MTSK-40 MODULARE WERKZEUGAUFNAHMEN SIEHE SEITE TBL300-1-40

Cod. MT	Mandrino Spindle Spindel	I	RPM	Coppia Max Max Torque Max Drehmoment	Reversibile lato mandrino/contromandrino Reversible sub/main spindle side Umkehrbare Spindel-seite/Gegenspindel-seite	Lubr.esterna Ext. coolant Aussenkuehlung	CHIAVI INCLUDE Keys included Schluessel einbegriffen
NKM1240100	MTSK-40	1:1	6000	50Nm	X	X	n°2 CHUB46

NAKAMURA-TOME

WT150/250 - WT150II/250II - WTW150 - WTS150 - SUPER NTM3 - SUPER NTJ - SUPER NTJX - SC150/200/250
 NTY3 150/250 - TW10M/MY/MM/MMY/MMYY-TW20M/MY/MM/MMY/MMYY 16 ST. - WY 150/250 - AS200MY 15/24 ST.

MODULO MOTORIZZATO ASSIALE MTSK PER POWER SKIVING H=85mm

Axial MTSK driven tool for Power Skiving H=85mm

Axial MTSK angetriebenes Werkzeug fuer Power Skiving H=85mm

Subject to change without notice.

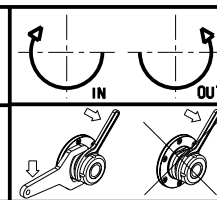

M.T. srl
 Via Casino Albini 480
 Tel. 0541/956034-957884
 Fax 0541/956341
 47842 S. GIOVANNI IN M. (RN)
 e-mail: mtma@mtmarchetti.com
 http://www.mtmarchetti.com

PRODUZIONE MODULI ROTANTI



PAGINA NKM350-2-00-K

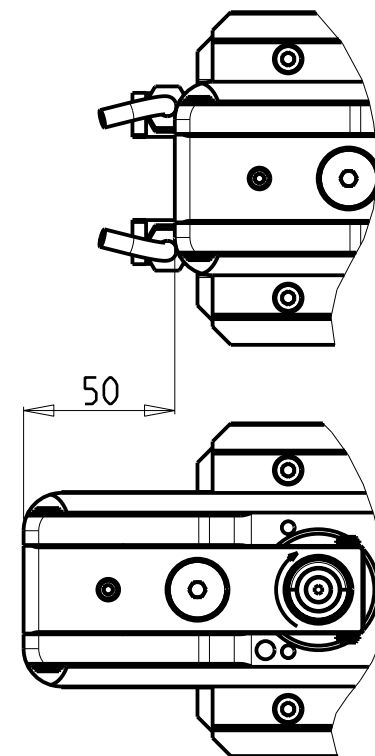
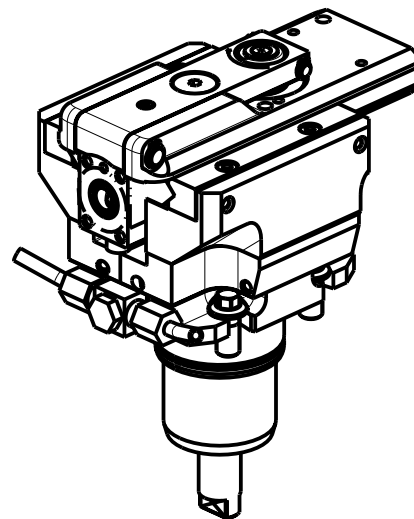
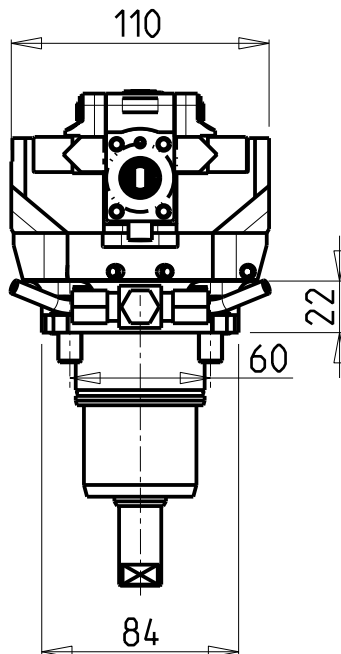
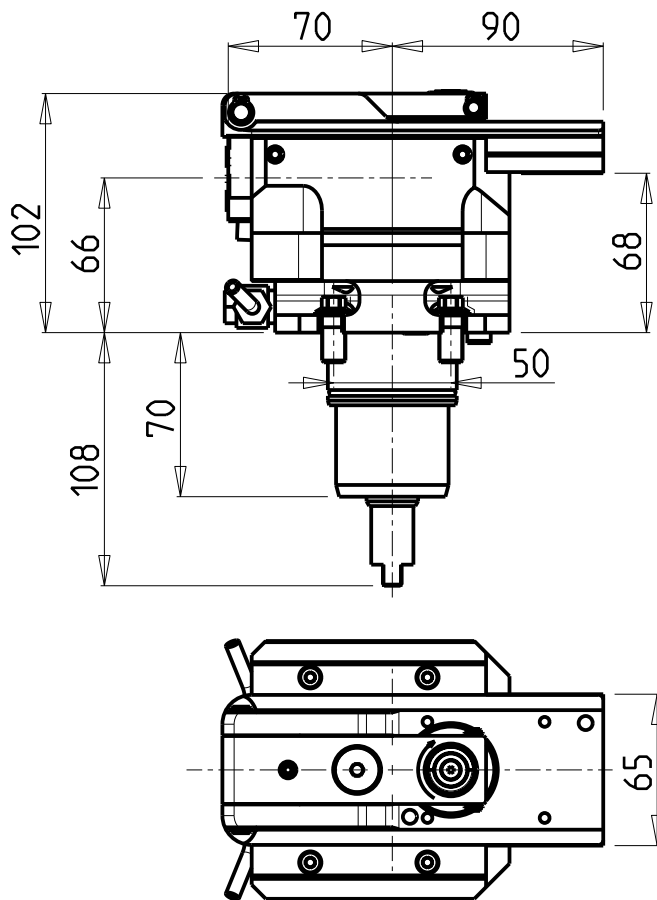

PER UTENSILI STOZZATORI VEDI PAG. TBL400-1-00
 FOR DRIVEN SLOTTING TOOL CUTTING-TOOLS SEE PAGE TBL400-1-00
 FÜR NUTENSTOSS-WERKZEUG SCHNEIDWERKZEUGE SIEHE SEITE TBL400-1-00

Cod. MT	I	RPM MAX	Reversibile lato mandrino/contromandrino Reversible sub/main spindle side Umkehrbare Spindel-seite/ Gegenspindel-seite	Lubr. esterna Ext. coolant Aussenkuehlung
NKM0910100	4:1	2000	X	X

NAKAMURA-TOME

WT150 - SUPER NTJ - SUPER NTM3 - WY 150/250 - AS200 15ST.

MODULO MOTORIZZATO STOZZATORE CORSA 50mm H=66mm

Slotting driven tool 50mm stroke H=66mm

Keilnutenstossmaschine 50mm Hub H=66mm

Subject to change without notice.

M.T. srl

Via Casino Albini 480
 Tel. 0541/956034-957884
 Fax 0541/956341
 47842 S. GIOVANNI IN M. (RN)
 e-mail: mtma@mtmarchetti.com
 http://www.mtmarchetti.com

PRODUZIONE MODULI ROTANTI



PAGINA NKM360-2-00

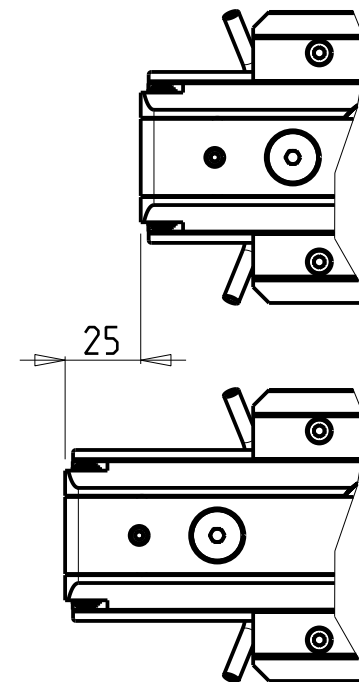
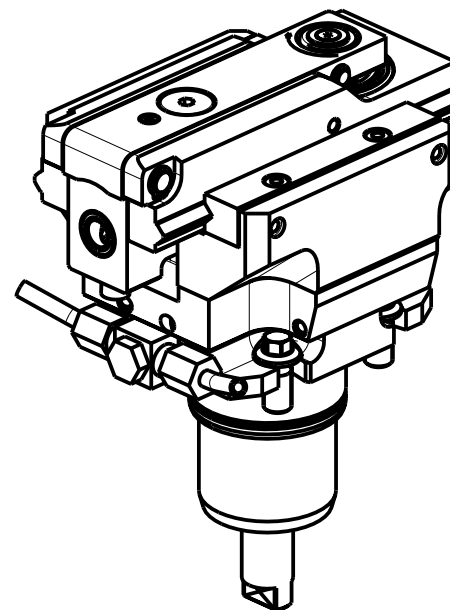
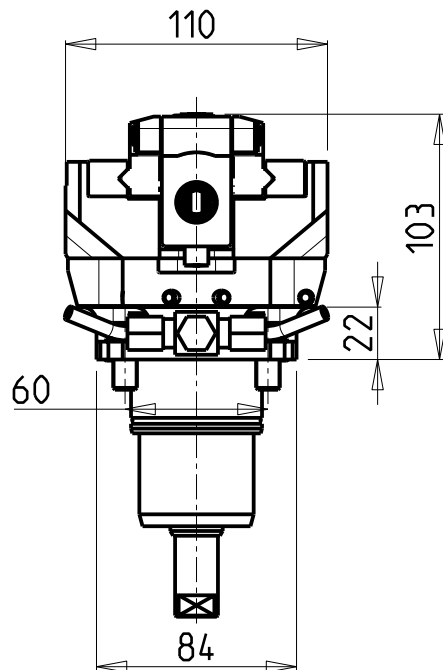
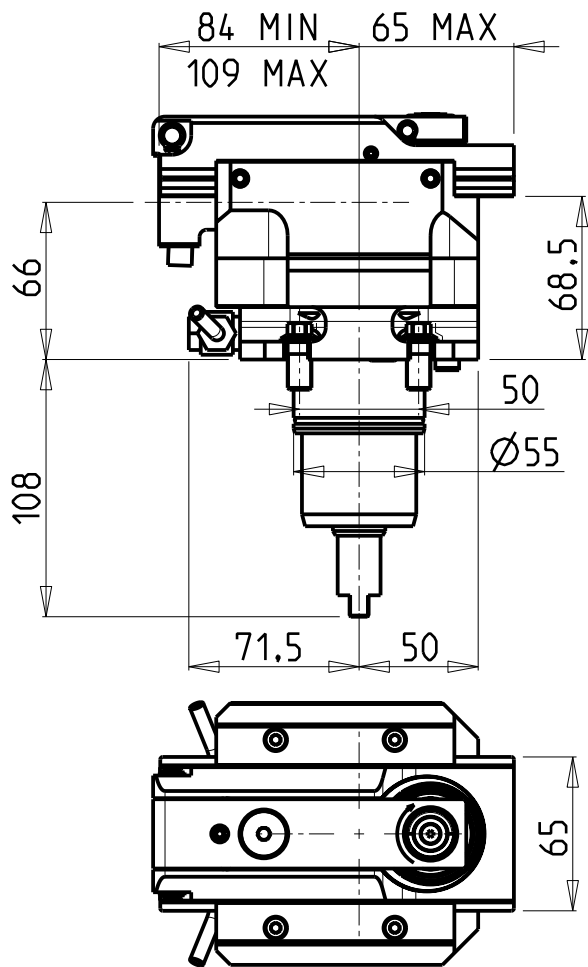

PER UTENSILI STOZZATORI VEDI PAG. TBL400-1-00
 FOR DRIVEN SLOTTING TOOL CUTTING-TOOLS SEE PAGE TBL400-1-00
 FÜR NUTENSTOSS-WERKZEUG SCHNEIDWERKZEUGE SIEHE SEITE TBL400-1-00

Cod. MT	I	RPM MAX	Reversibile lato mandrino/contromandrino Reversible sub/main spindle side Umkehrbare Spindel-seite/ Gegenspindel-seite	Lubr. esterna Ext. coolant Aussenkuehlung
NKM0910200	4:1	2400	X	X

NAKAMURA-TOME

WT150 - SUPER NTJ - SUPER NTM3 - WY 150/250 - AS200 15ST.

MODULO MOTORIZZATO STOZZATORE CORSA 25mm H=66mm

Slotting driven tool 25mm stroke H=66mm

Keilnutenstossmaschine 25mm Hub H=66mm

Subject to change without notice.

M.T. srl

Via Casino Albini 480
 Tel. 0541/956034-957884
 Fax 0541/956341
 47842 S. GIOVANNI IN M. (RN)
 e-mail: mtma@mtmarchetti.com
 http://www.mtmarchetti.com

PRODUZIONE MODULI ROTANTI



PAGINA NKM360-2-01

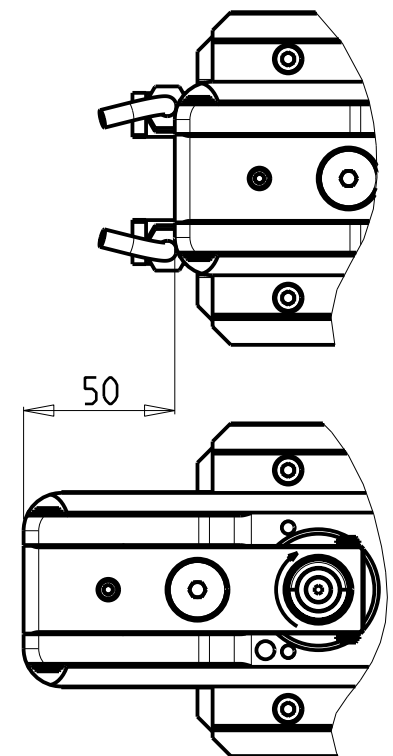
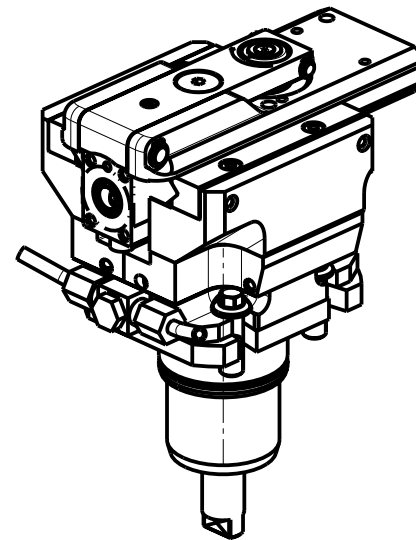
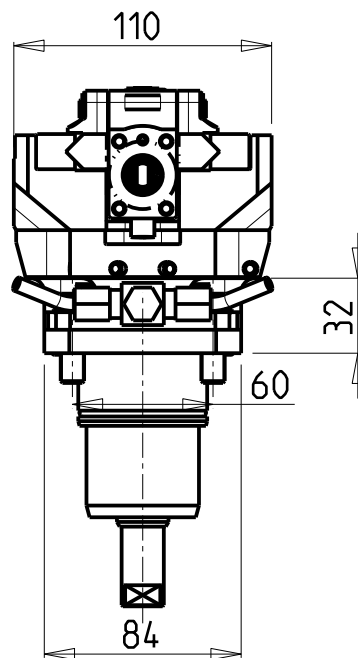
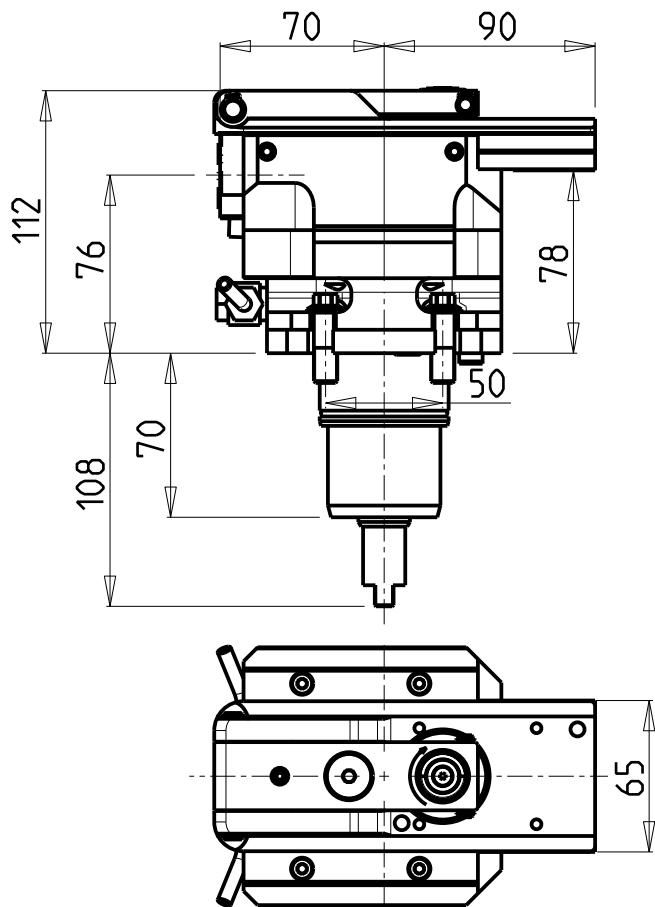

PER UTENSILI STOZZATORI VEDI PAG. TBL400-1-00
 FOR DRIVEN SLOTTING TOOL CUTTING-TOOLS SEE PAGE TBL400-1-00
 FÜR NUTENSTOSS-WERKZEUG SCHNEIDWERKZEUGE SIEHE SEITE TBL400-1-00

Cod. MT	I	RPM MAX	Reversibile lato mandrino/contromandrino Reversible sub/main spindle side Umkehrbare Spindel-seite/ Gegenspindel-seite	Lubr. esterna Ext. coolant Aussenkuehlung
NKM0920100	4:1	2000	X	X

NAKAMURA-TOME

WT250 - WT150II/250II - WTW150 - WTS150 - SC150/200/250 - SUPER NTJX - NTY3 150/250

MODULO MOTORIZZATO STOZZATORE CORSA 50mm H=76mm
 Slotting driven tool 50mm stroke H=76mm
 Keilnutenstossmaschine 50mm Hub H=76mm

Subject to change without notice.

M.T. srl

Via Casino Albini 480
 Tel. 0541/956034-957884
 Fax 0541/956341
 47842 S. GIOVANNI IN M. (RN)
 e-mail: mtma@mtmarchetti.com
 http://www.mtmarchetti.com

PRODUZIONE MODULI ROTANTI



PAGINA NKM360-2-10

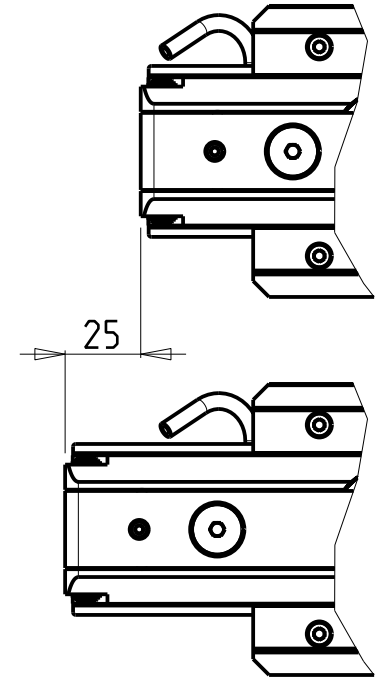
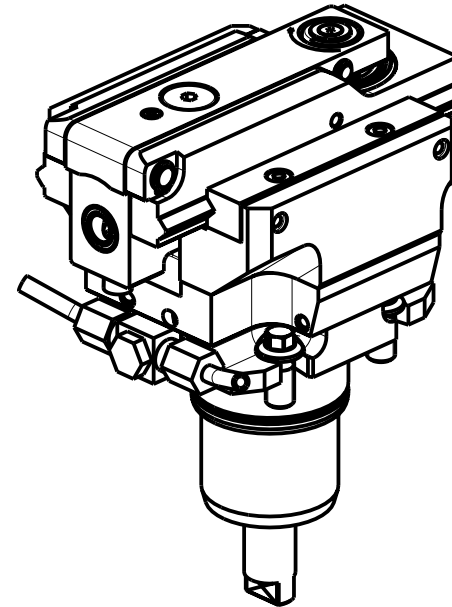
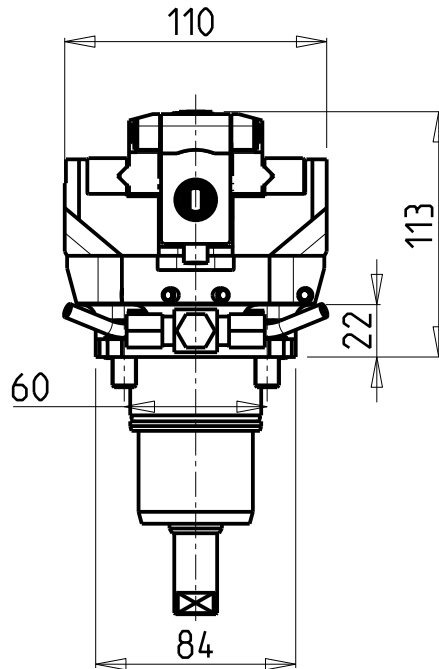
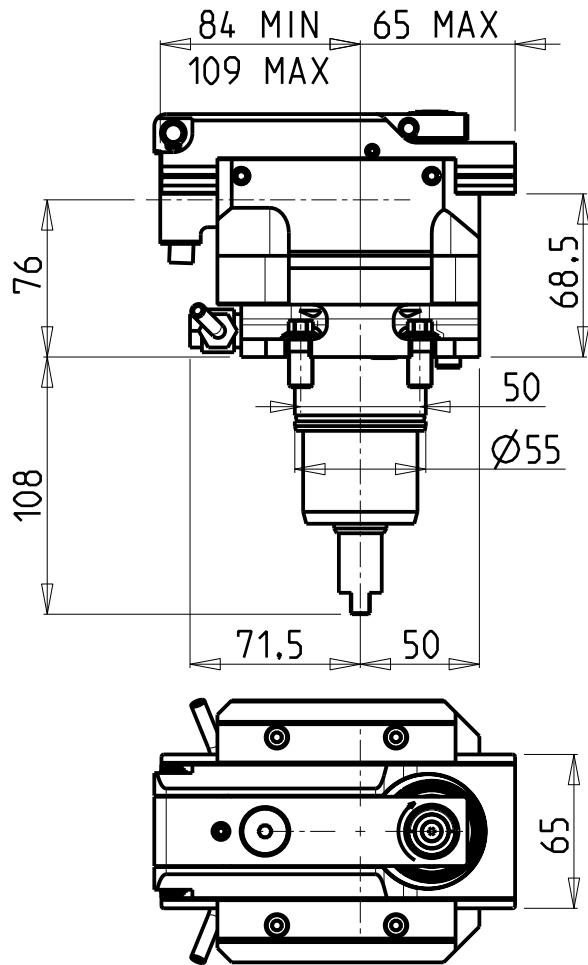

PER UTENSILI STOZZATORI VEDI PAG. TBL400-1-00
 FOR DRIVEN SLOTTING TOOL CUTTING-TOOLS SEE PAGE TBL400-1-00
 FÜR NUTENSTOSS-WERKZEUG SCHNEIDWERKZEUGE SIEHE SEITE TBL400-1-00

Cod. MT	I	RPM MAX	Reversibile lato mandrino/contromandrino Reversible sub/main spindle side Umkehrbare Spindel-seite/ Gegenspindel-seite	Lubr. esterna Ext. coolant Aussenkuehlung
NKM0920200	4:1	2400	X	X

NAKAMURA-TOME

WT250 - WT15011/25011 - WTW150 - WTS150 - SC150/200/250 - SUPER NTJX - NTY3 150/250

MODULO MOTORIZZATO STOZZATORE CORSA 25mm H=76mm
 Slotting driven tool 25mm stroke H=76mm
 Keilnutenstossmaschine 25mm Hub H=76mm

Subject to change without notice.

M.T. srl

Via Casino Albini 480
 Tel. 0541/956034-957884
 Fax 0541/956341
 47842 S. GIOVANNI IN M. (RN)
 e-mail: mtma@mtmarchetti.com
 http://www.mtmarchetti.com

PRODUZIONE MODULI ROTANTI



PAGINA NKM360-2-11

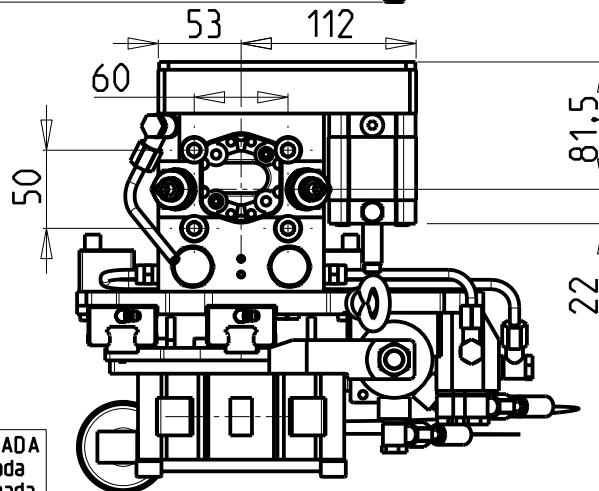
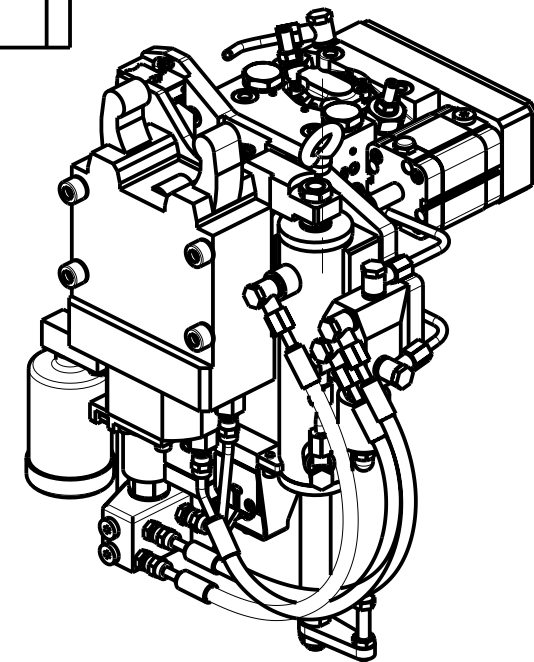
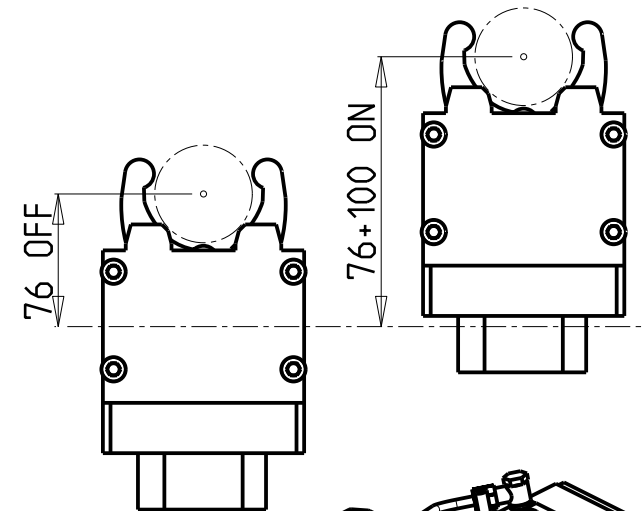
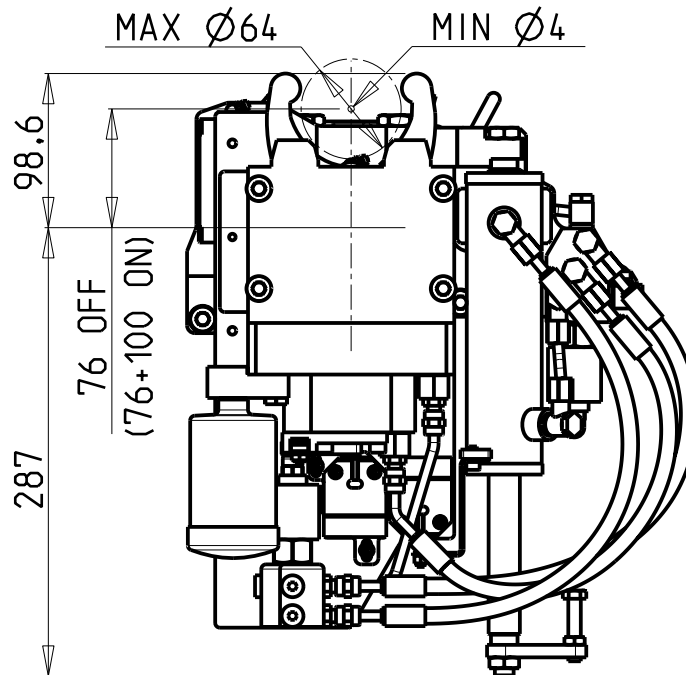
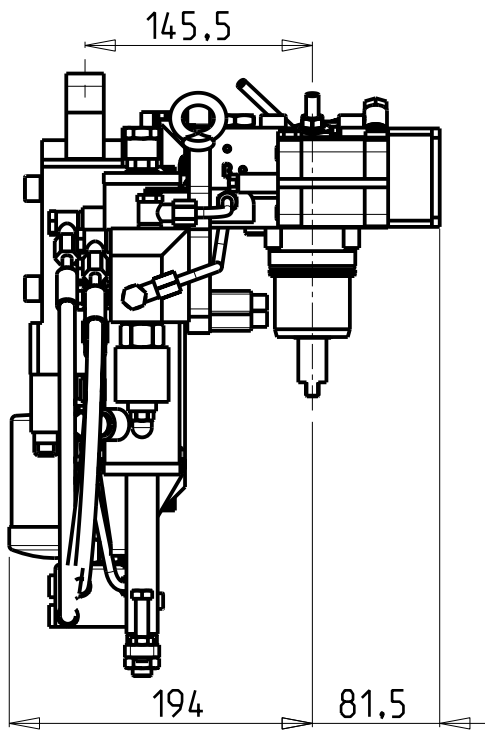

- # CON GESTIONE ELETTRONICA APERTURA COMPLETA DELLA LUNETTA
- # With Electronic control of steady rest arms complete opening
- # Mit vollstaendiger elektronischer Oeffnungsbedienung der Luenette

Cod. MT	I	RPM	Lubr.esterna Ext. coolant Aussenkuehlung
NKM0760300	1:1	6000	X
# NKM0760300EU	1:1	6000	X
# NKM0760300US	1:1	6000	X

PER U.S.A.-AUSTRALIA-CANADA
For U.S.A.-Australia-Canada
Fuer U.S.A.-Australien-Kanada

NAKAMURA-TOME

WT150/250 - WT15011/25011 - WTW150 - WTS150 - SUPER NTM3 - SUPER NTJ - SUPER NTJX - NTY3 150/250

MODULO MOTORIZZATO PER LUNETTA RETRATTILE (TAGLIA 1)
Driven toolholder for sliding steady rest (Size 1)
Luenettenwerkzeug zurueck versetzte Version (Grossesse 1)

Subject to change without notice.

M.T. srl

Via Casino Albini 480
Tel. 0541/956034-957884
Fax 0541/956341
47842 S. GIOVANNI IN M. (RN)
e-mail: mtma@mtmarchetti.com
http://www.mtmarchetti.com

PRODUZIONE MODULI ROTANTI



PAGINA NKM363-2-00

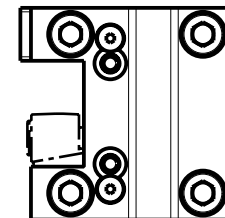
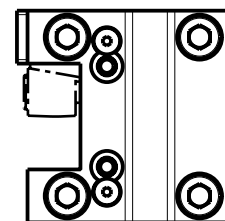
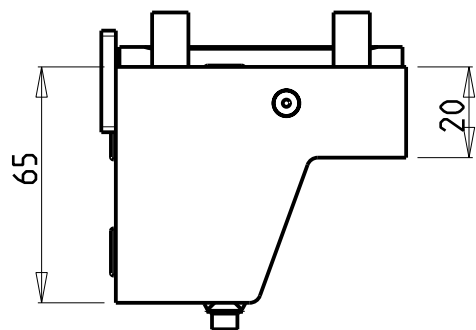
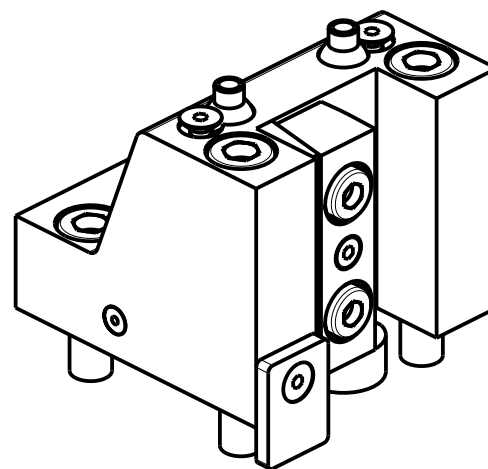
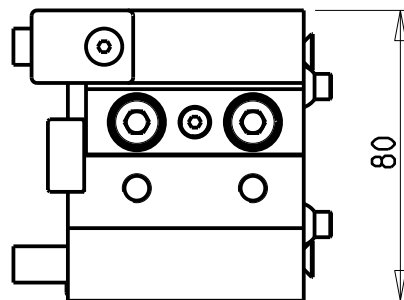
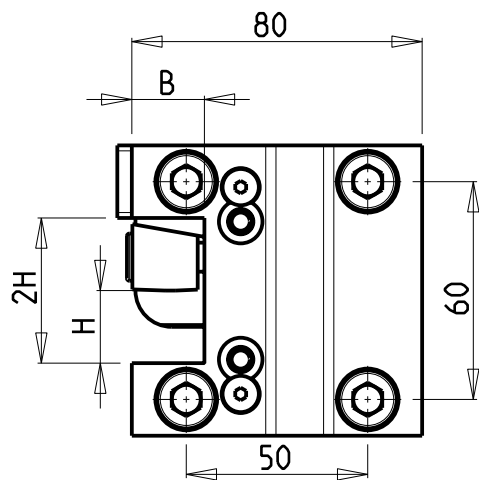

Cod. MT	Cod. NAKAMURA	N°Utensili N°Tools N°Werkzeuge	Reversibile lato mandrino/contromandrino Reversible sub/main spindle side Umkehrbare Spindel-seite/ Gegenspindel-seite	Misure Dimensions Masse	B	H
NKM0162000	W 14 31/W 14 32	1	X	mm	20	20
NKM0161905	W 14 41/W 14 42	1	X	Inch	3/4"	3/4"

NAKAMURA - TOME

WT150/250 - WT15011/25011 - WTW150 - WTS150 - SUPER NTM3 - SUPER NTJ - SUPER NTJX - SC150/200/250
 NTY3 150/250 - TW10M/MY/MM/MMY/MMYY-TW20M/MY/MM/MMY/MMYY 16 ST. - WY 150/250 - AS200 15/24 ST.

PORTAUTENSILE RADIALE SINGOLO QD=20mm / QD=3/4"

Radial single static tool QD=20mm / QD=3/4"

Radial Single-Werkzeughalter QD=20mm / QD=3/4"

Subject to change without notice.

M.T. srl

Via Casino Albini 480
 Tel. 0541/956034-957884
 Fax 0541/956341

47842 S. GIOVANNI IN M. (RN)
 e-mail: mtma@mtmarchetti.com
 http://www.mtmarchetti.com

PRODUZIONE MODULI ROTANTI



PAGINA NKM420-2-00

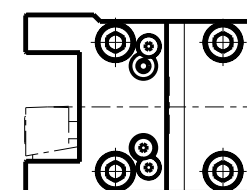
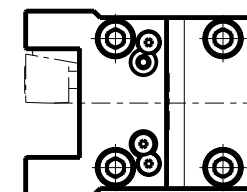
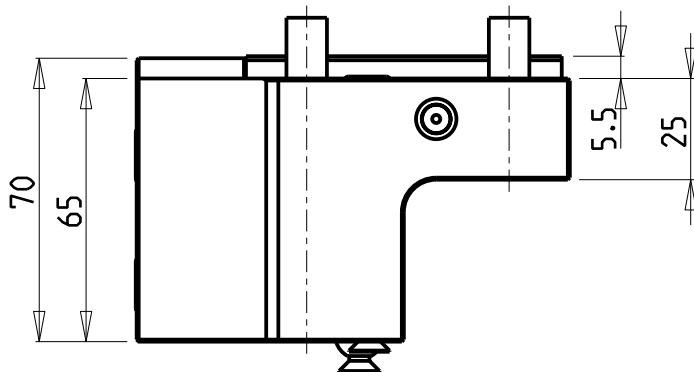
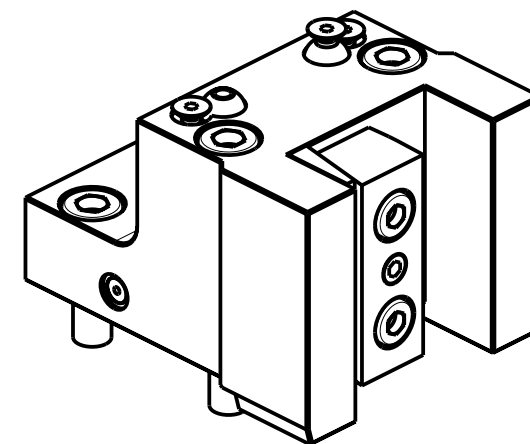
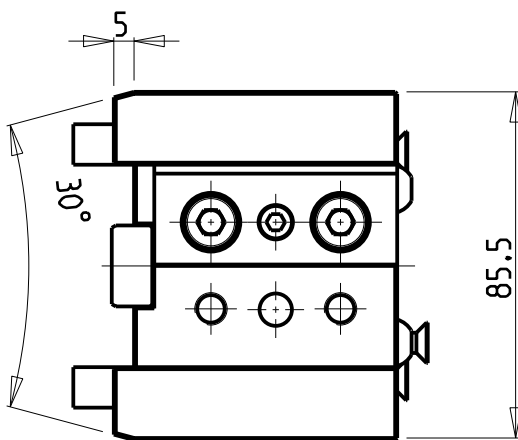
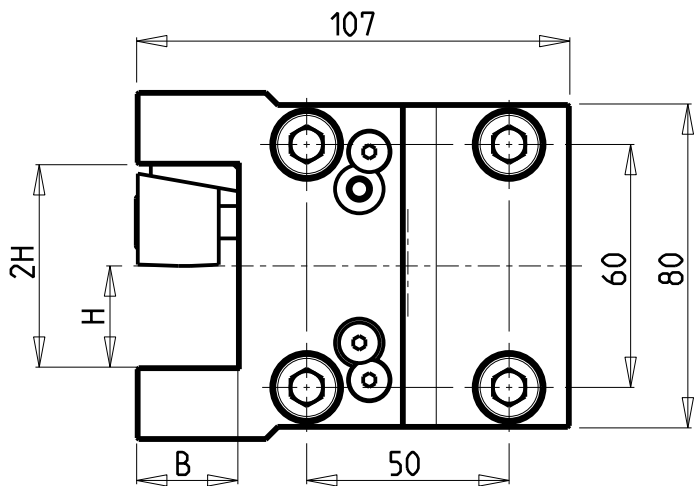

Cod. MT	Reversibile lato mandrino/contromandrino Reversible sub/main spindle side Umkehrbare Spindelsete/ Gegenspindelsete	Misure Dimensions Masse	B	H
NKM0162500	X	mm	25	25
NKM0162540	X	Inch	1"	1"

NAKAMURA-TOME

WT150/250 - WT15011/25011 - WTW150 - WTS150 - SUPER NTM3 - SUPER NTJ - SUPER NTJX - SC150/200/250
 NTY3 150/250 - TW10M/MY/MM/MMY/MMYY-TW20M/MY/MM/MMY/MMYY 16 ST. - WY150/250 - AS200 15/24 ST.

PORTAUTENSILE RADIALE SINGOLO QD=25mm / QD=1"

Radial single static tool QD=25mm / QD=1"

Radial Single-Werkzeughalter QD=25mm / QD=1"

Subject to change without notice.

M.T. srl

Via Casino Albini 480
 Tel. 0541/956034-957884
 Fax 0541/956341
 47842 S. GIOVANNI IN M. (RN)
 e-mail: mtma@mtmarchetti.com
 http://www.mtmarchetti.com

PRODUZIONE MODULI ROTANTI



PAGINA NKM423-2-00

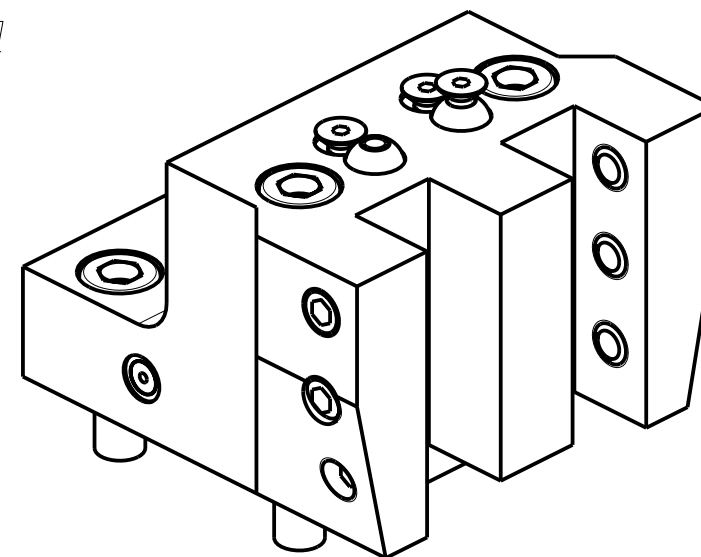
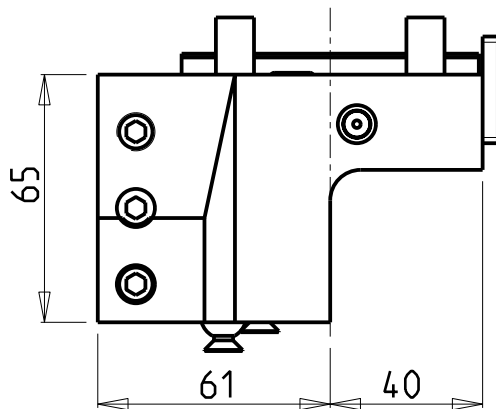
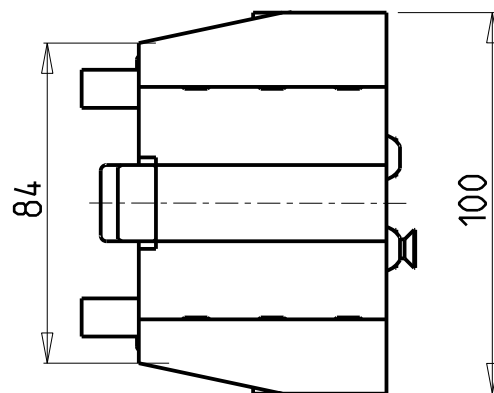
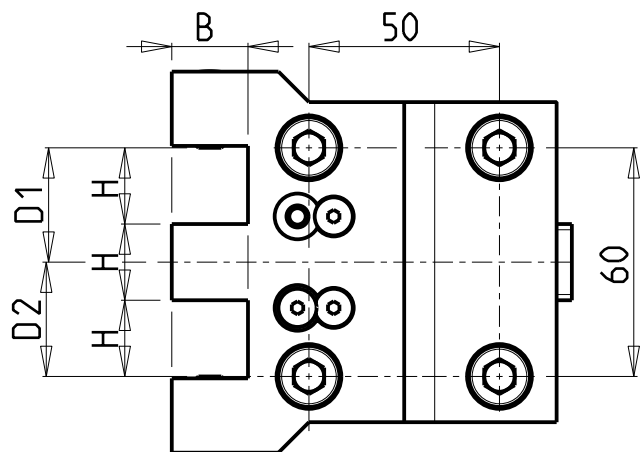

Cod. MT	N°Utensili N°Tools N°Werkzeuge	Reversibile lato mandrino/contromandrino Reversible sub/main spindle side Umkehrbare Spindel-seite/ Gegenspindel-seite	Misure Dimensions Masse	H	B	D1	D2
NKM1052000	2	X	mm	20	20	30	30
NKM1051905	2	X	inch	3/4"	3/4"	1 1/8"	1 1/8"

NAKAMURA-TOME

WT150/250 - WT15011/25011 - WTW150 - WTS150 - SUPER NTM3 - SUPER NTJ - SUPER NTJX - SC150/200/250
 NTY3 150/250 - TW10M/MY/MM/MYY/MYY-TW20M/MY/MM/MYY/MYY 16 ST. - WY150/250 - AS200MY 15/24 ST.

PORTAUTENSILE RADIALE SOVRAPPOSTO QD=20mm / QD=3/4"

Radial single side twin static tool QD=20mm / QD=3/4"

Radial Werkzeughalter ueberlagert QD=20mm / QD=3/4"

Subject to change without notice.

M.T. srl

Via Casino Albini 480
 Tel. 0541/956034-957884
 Fax 0541/956341
 47842 S. GIOVANNI IN M. (RN)
 e-mail: mtma@mtmarchetti.com
 http://www.mtmarchetti.com

PRODUZIONE MODULI ROTANTI



PAGINA NKM440-2-00

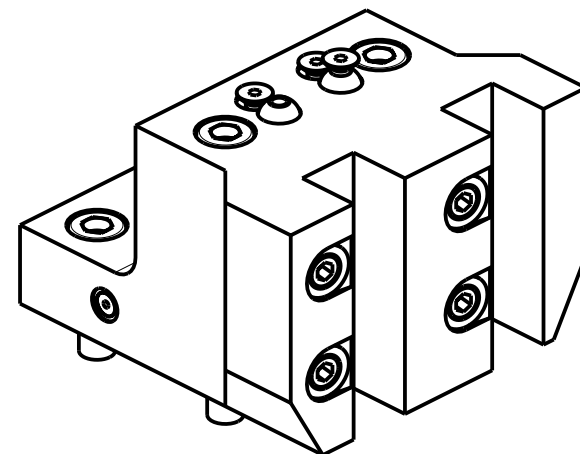
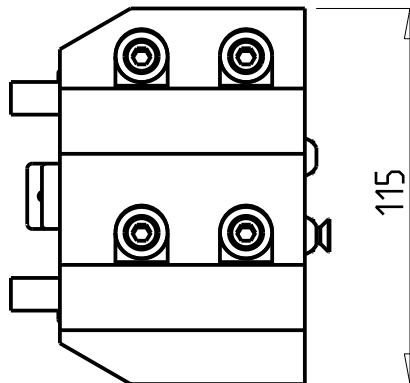
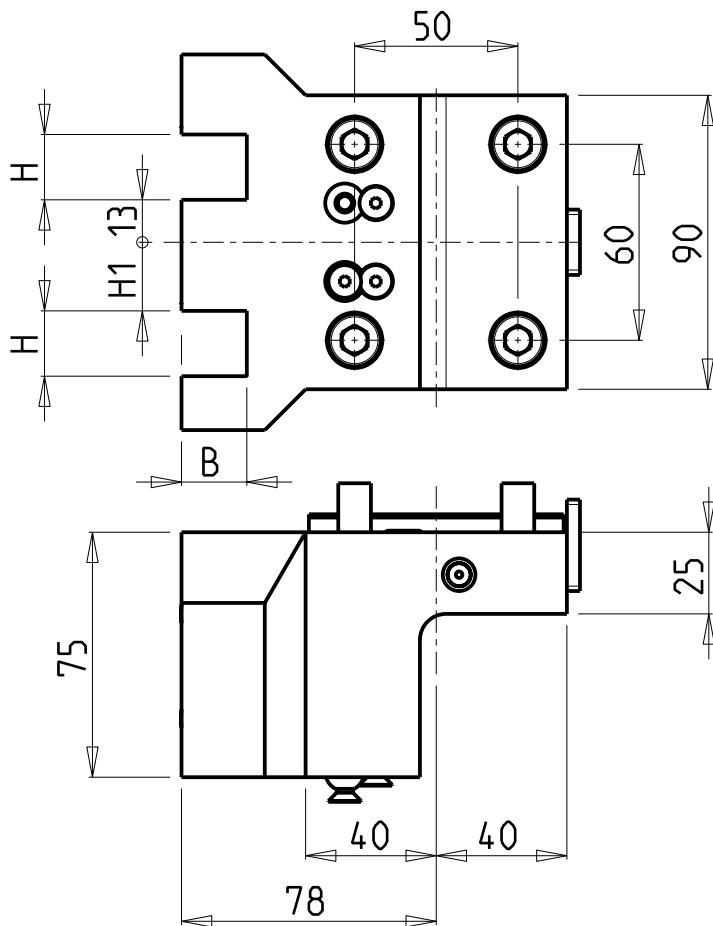

Cod. MT	Reversibile lato mandrino/contromandrino Reversible sub/main spindle side Umkehrbare Spindel-seite/ Gegenspindel-seite	Misure Dimensions Masse	B	H	H1
NKM1102000	X	mm	20	20	21
NKM1101905	X	inch	3/4"	3/4"	21.95

NAKAMURA-TOME

WT150/250 - WT15011/25011 - WTW150 - WTS150 - SUPER NTM3 - SUPER NTJ - SUPER NTJX - SC150/200/250
 NTY3 150/250 - WY 150/250 - AS200MY 24 ST.

PORTAUTENSILE RADIALE SOVRAPPOSTO QD=20mm / QD=3/4"

Radial single side twin static tool QD=20mm / QD=3/4"

Radial Werkzeughalter ueberlagert QD=20mm / QD=3/4"

Subject to change without notice.

M.T. srl

Via Casino Albini 480
 Tel. 0541/956034-957884
 Fax 0541/956341
 47842 S. GIOVANNI IN M. (RN)
 e-mail: mtma@mtmarchetti.com
 http://www.mtmarchetti.com

PRODUZIONE MODULI ROTANTI



PAGINA NKM440-2-10

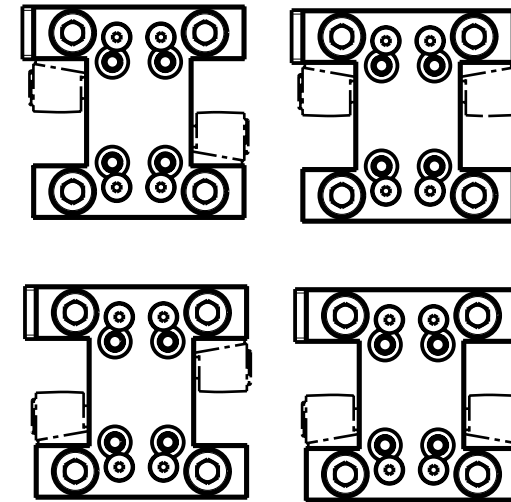
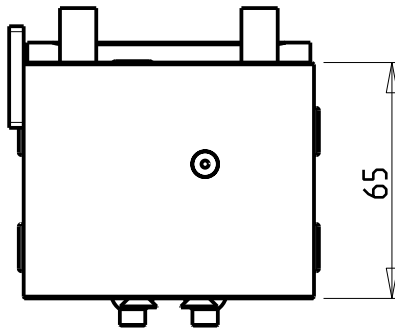
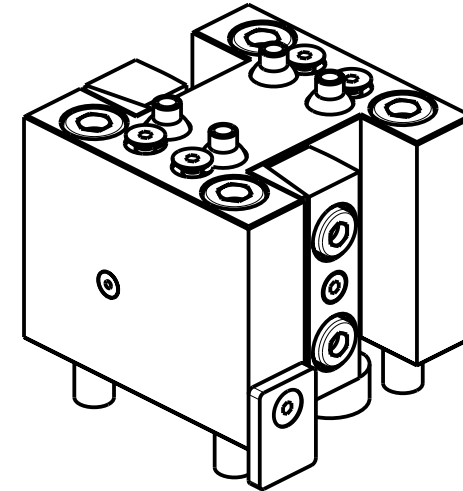
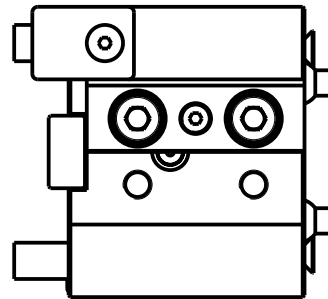
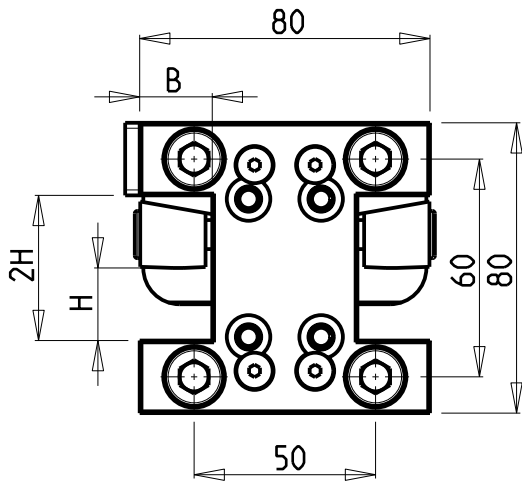

Cod. MT	N°Utensili N°Tools N°Werkzeuge	Reversibile lato mandrino/contromandrino Reversible sub/main spindle side Umkehrbare Spindel-seite/ Gegenspindel-seite	Misure Dimensions Masse	B	H
NKM0152000	2	X	mm	20	20
NKM0151905	2	X	Inch	3/4"	3/4"

NAKAMURA - TOME

WT150/250 - WT15011/25011 - WTW150 - WTS150 - SUPER NTM3 - SUPER NTJ - SUPER NTJX - SC150/200/250
 NTY3 150/250 - TW10M/MY/MM/MMY/MMYY-TW20M/MY/MM/MMY/MMYY 16 ST. - WY 150/250 - AS200 15/24 ST.

PORTAUTENSILE RADIALE DOPPIO QD=20mm / QD=3/4"

Radial double static tool QD=20mm / QD=3/4"

Radial Doppel-Werkzeughalter QD=20mm / QD=3/4"

Subject to change without notice.

M.T. srl

Via Casino Albini 480
 Tel. 0541/956034-957884
 Fax 0541/956341
 47842 S. GIOVANNI IN M. (RN)
 e-mail: mtma@mtmarchetti.com
 http://www.mtmarchetti.com

PRODUZIONE MODULI ROTANTI



PAGINA NKM450-2-00

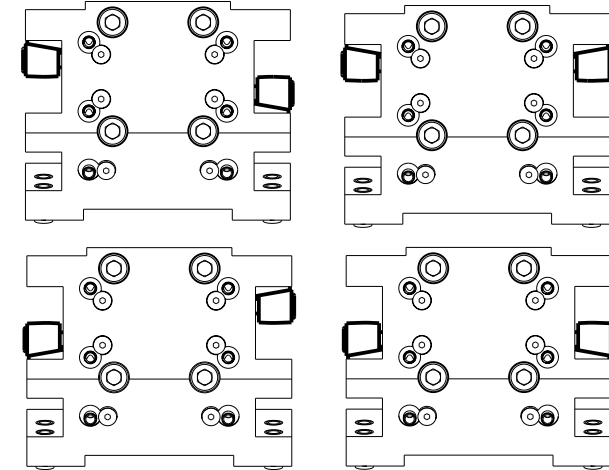
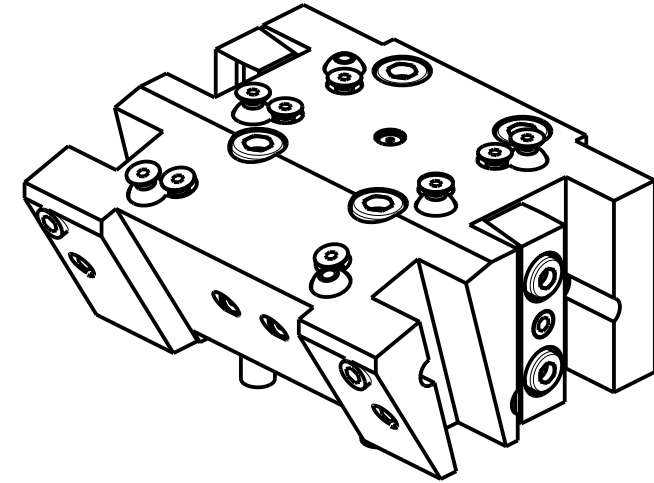
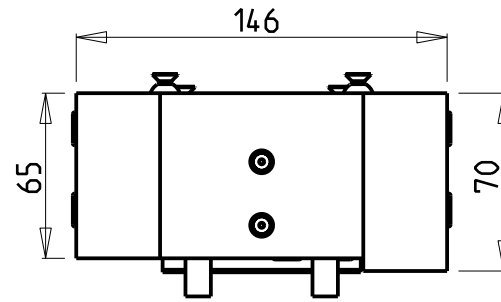
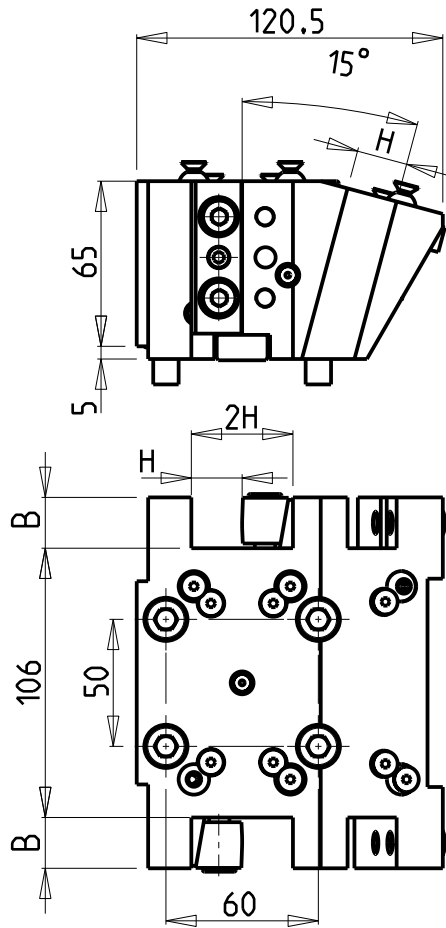

Cod. MT	N°Utensili N° Tools N° Werkzeuge	Reversibile lato mandrino/contromandrino Reversible sub/main spindle side Umkehrbare Spindel-seite/ Gegenspindel-seite	Misure Dimensions Masse	B	H
NKM0221000	4	X	mm	20	20
NKM0221905	4	X	Inch	3/4"	3/4"

NAKAMURA-TOME

MOD: WT150 - WY 150/250 - WT15011/25011 - SUPER NTM3 - NTY3 150/250
 SUPER NTJ torretta inferiore/lower turret/unterer revolver

PORTAUTENSILE RADIALE MULTIPLIO QD=20mm / QD=3/4"

Radial multiple static tool QD=20mm / QD=3/4"

Radial Mehrfach-Halter QD=20mm / QD=3/4"

Subject to change without notice.

M.T. srl

Via Casino Albini 480
 Tel. 0541/956034-957884
 Fax 0541/956341
 47842 S. GIOVANNI IN M. (RN)
 e-mail: mtma@mtmarchetti.com
 http://www.mtmarchetti.com

PRODUZIONE MODULI ROTANTI



PAGINA NKM470-2-00

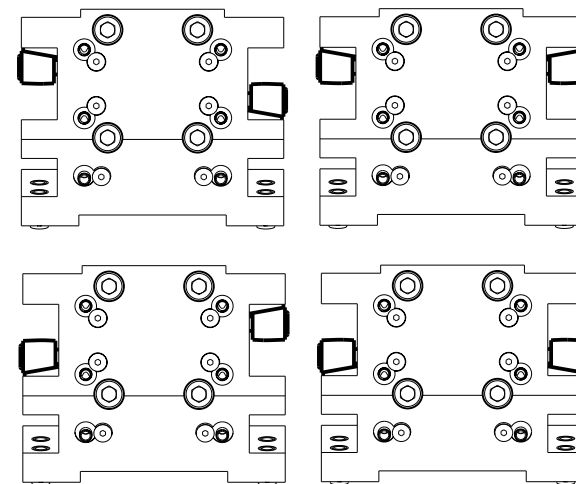
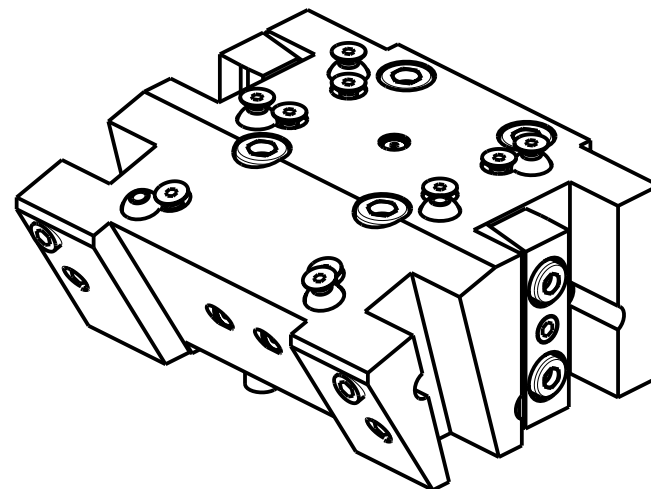
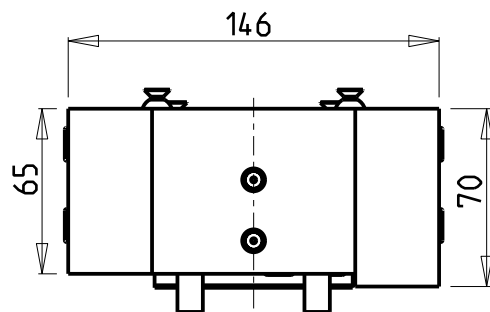
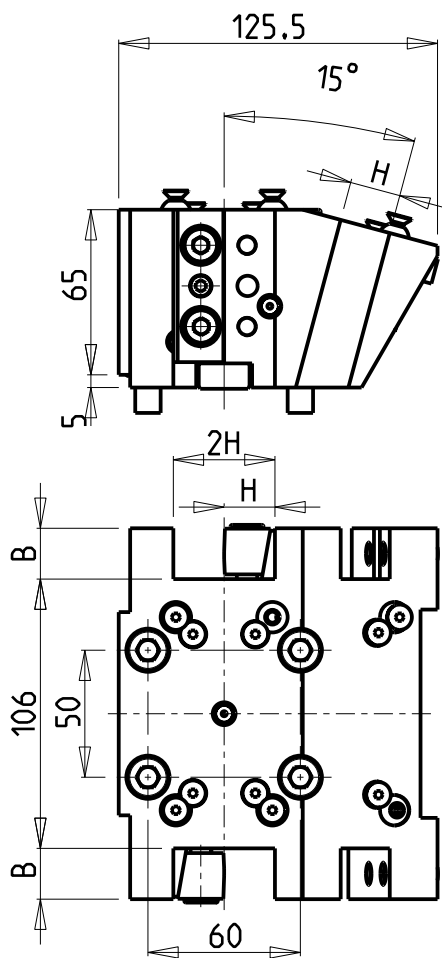

Cod. MT	N°Utensili N°Tools N°Werkzeuge	Reversibile lato mandrino/contromandrino Reversible sub/main spindle side Umkehrbare Spindel-seite/ Gegenspindel-seite	Misure Dimensions Masse	B	H
NKM0222000	4	X	mm	20	20

NAKAMURA-TOME

MOD: WTW150 - WTS150 - SUPER NTJX - AS200 24 ST.

PORTAUTENSILE RADIALE MULTIPLIO QD=20mm

Radial multiple static tool QD=20mm

Radial Mehrfach-Halter QD=20mm

Subject to change without notice.

M.T. srl

Via Casino Albini 480
Tel. 0541/956034-957884
Fax 0541/956341
47842 S. GIOVANNI IN M. (RN)
e-mail: mtma@mtmarchetti.com
<http://www.mtmarchetti.com>

PRODUZIONE MODULI ROTANTI



PAGINA NKM470-2-10

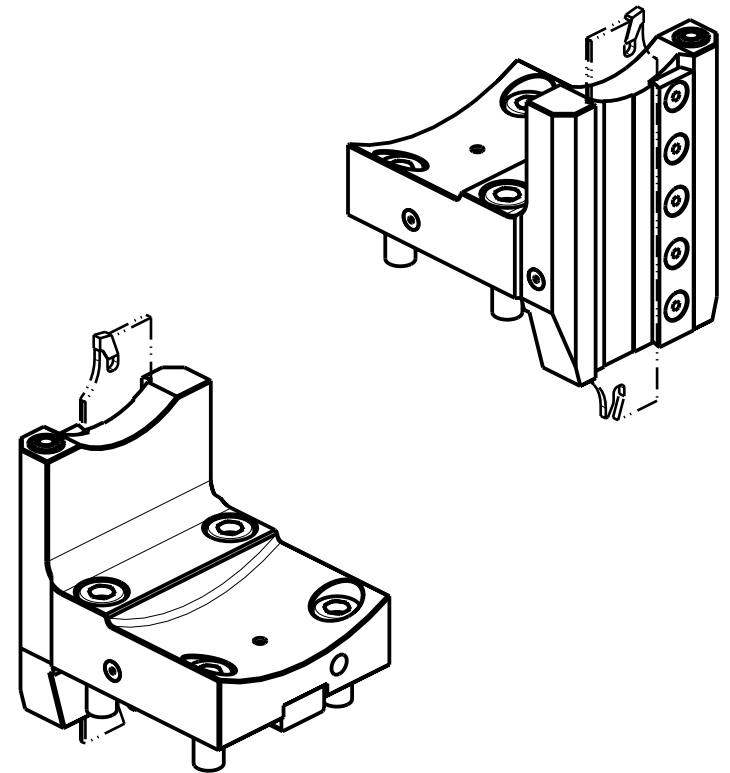
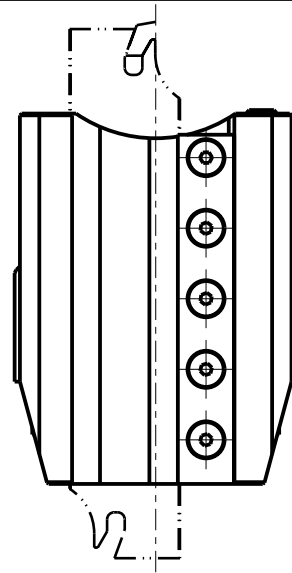
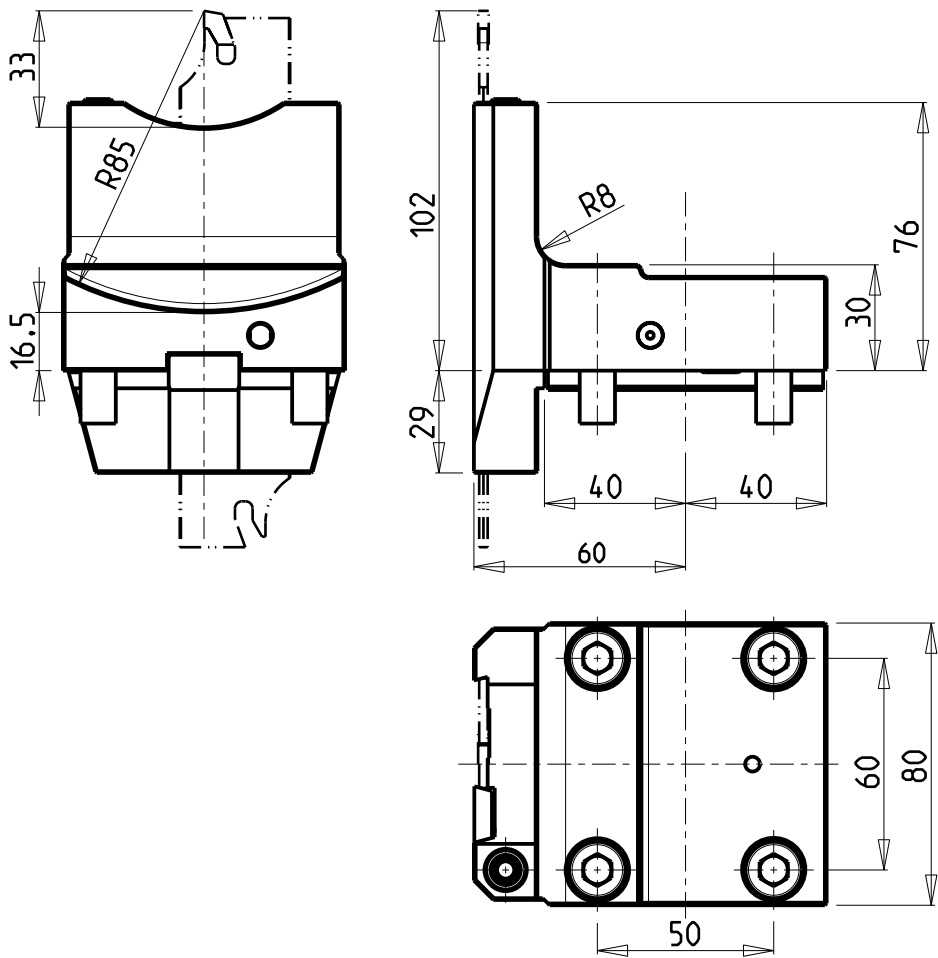

DOTAZIONI - SUPPLIED WITH - AUSSTATTUNG

- N°1 - LAMA - BLADE - KLINGE ISCAR H-32 Sp. 3/4mm (KENNAMETAL OPTIONAL)
- N°10 - INSERTI - INSERTS - EINLAGEN
- N°1 - CHIAVE A T PER MONTAGGIO INSERTI
- T-WRENCH FOR INSERT SET UP
- T-SCHLUESSEL FUER EINSATZSTUECK-MONTAGE

Cod. MT	N°Utensili N° Tools N°Werkzeuge	Reversibile lato mandrino/contromandrino Reversible sub/main spindle side Umkehrbare Spindel-seite/ Gegenspindel-seite
NKM0170132	1	X

NAKAMURA-TOME
 WT150/250 - WT15011/25011 - WTW150 - WTS150 - SUPER NTM3 - SUPER NTJ - SUPER NTJX - SC150/200/250
 NTY3 150/250 - TW10M/MY/MM/MMY/MMYY-TW20M/MY/MM/MMY/MMYY 16 ST. - WY 150/250 - AS200 15 ST.

PORTAUTENSILE RADIALE PER LAMA
 Radial blade holder
 Radial Abstechhalter

M.T. srl
 Via Casino Albini 480
 Tel. 0541/956034-957884
 Fax 0541/956341
 47842 S. GIOVANNI IN M. (RN)
 e-mail: mtma@mtmarchetti.com
 http://www.mtmarchetti.com

PRODUZIONE MODULI ROTANTI



PAGINA NKM510-2-00

Subject to change without notice.

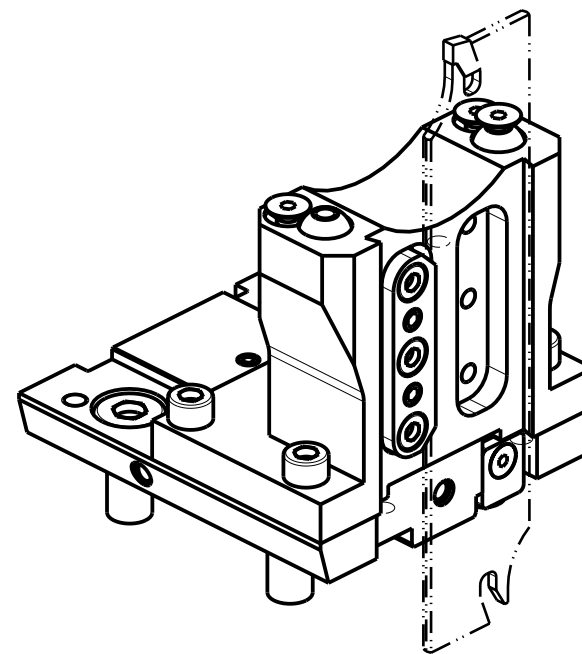
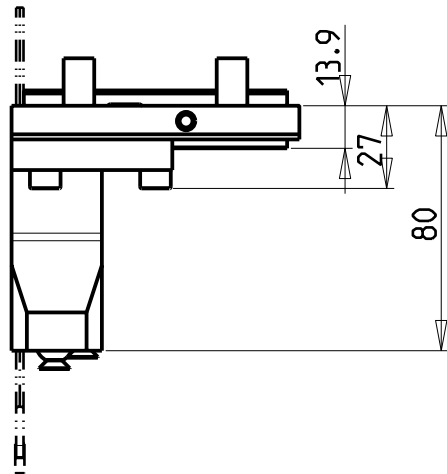
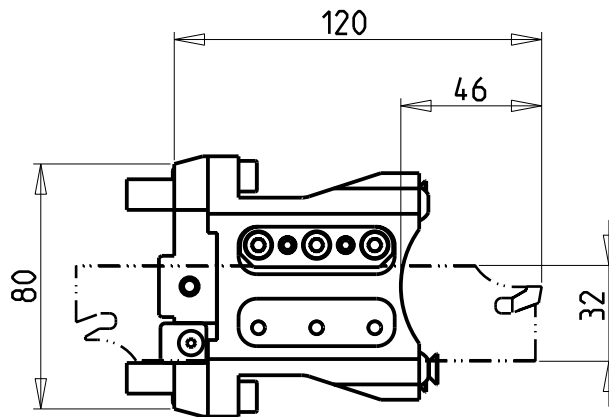
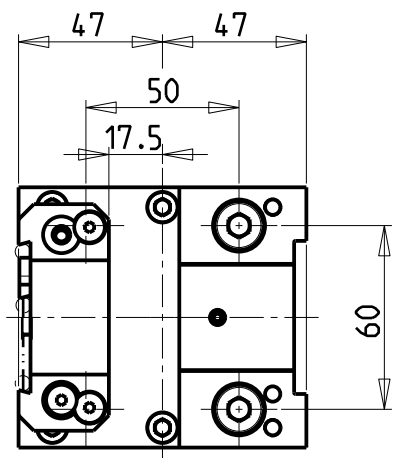

POSSIBILITA' DI LAVORO M3/M4
 OPTION OF M3/M4 WORKING
 ARBEITSMÖGLICHKEIT M3/M4

DOTAZIONI - SUPPLIED WITH - AUSSTATTUNG

N°1 - LAMA - BLADE - KLINGE ISCAR H=32 Sp. 3/4mm
 (KENNAMETAL OPTIONAL)

N°10 - INSERTI - INSERTS - EINLAGEN

N°1 - CHIAVE A T PER MONTAGGIO INSERTI
 - T-WRENCH FOR INSERT SET UP
 - T-SCHLUESSEL FUER EINSATZSTUECK-MONTAGE

Cod. MT	N°Utensili N°Tools N°Werkzeuge	Reversibile lato mandrino/contromandrino Reversible sub/main spindle side Umkehrbare Spindelseite/ Gegenspindelseite	Lubr.esterna Ext. coolant Aussenkuehlung
NKM1030132	1	X	X

NAKAMURA-TOME

WT150/250 - WT15011/25011 - WTW150 - WTS150 - SUPER NTM3 - SUPER NTJ - SUPER NTJX - SC150/200/250
 NTY3 150/250 - TW10M/MY/MM/MMY/MMYY-TW20M/MY/MM/MMY/MMYY 16 ST. - WY 150/250 - AS200 15/24 ST.

PORTAUTENSILE RADIALE PER LAMA

Radial blade holder
 Radial Abstechhalter

M.T. srl

Via Casino Albini 480
 Tel. 0541/956034-957884
 Fax 0541/956341
 47842 S. GIOVANNI IN M. (RN)
 e-mail: mtma@mtmarchetti.com
 http://www.mtmarchetti.com

PRODUZIONE MODULI ROTANTI



PAGINA NKM520-2-01

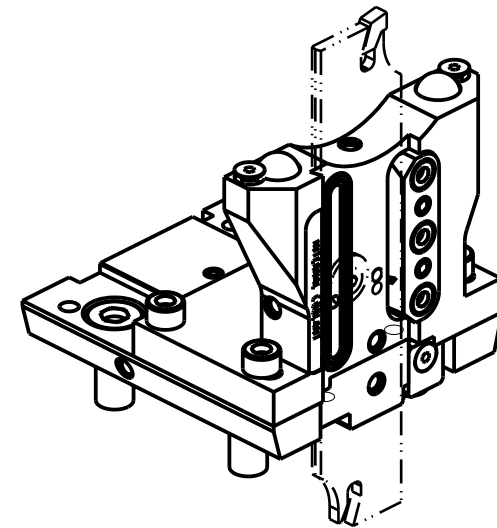
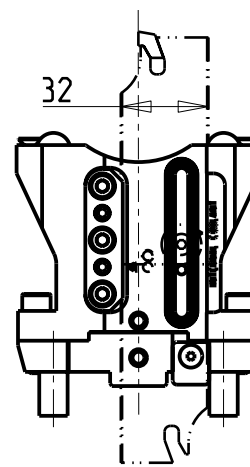
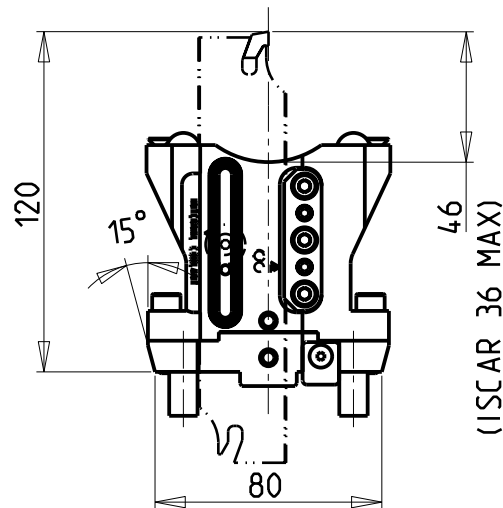
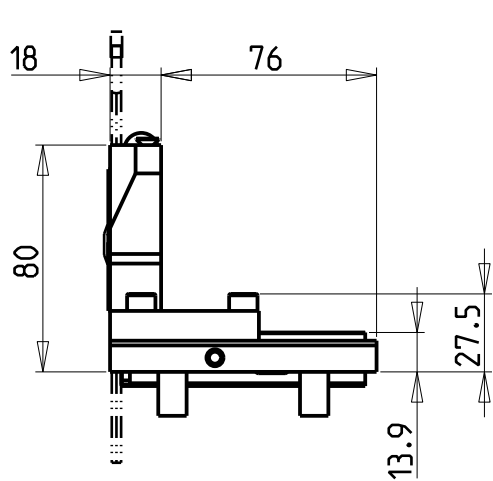

versione dx
right version
version rechts

versione sx
left version
version links

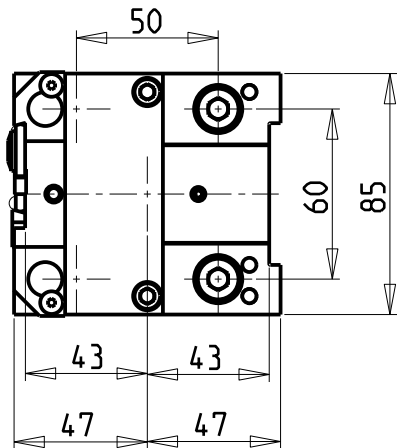

**KIT LAME NON INCLUSI (OPZIONALI)
BLADES NOT SUPPLIED WITH (OPTIONAL)
KLINGEN NICHT INBEGRIFFEN (OPTIONAL)**

- LAMA-BLADE-KLINGE SANDVIK H=32 sp.3 cod. QD_NN2G60C 25A
+INSERTI-INSERTS-EINLAGEN cod. QD_NG_0300_0002_CM_1145 (10 pz.)
- LAMA-BLADE-KLINGE SANDVIK H=32 sp.4 cod. QD_NN2H60C 25A
+INSERTI-INSERTS-EINLAGEN cod. QD_NH_0400_0002_CM_1145 (10 pz.)
- LAMA-BLADE-KLINGE ISCAR H=32 sp.3 cod. SGFH_32K_3
+INSERTI-INSERTS-EINLAGEN cod. 6011365 (10pz.)
- LAMA-BLADE-KLINGE ISCAR H=32 sp.4 cod. SGFH_32K_4
+INSERTI-INSERTS-EINLAGEN cod. 6011366 (10pz.)
- LAMA-BLADE-KLINGE WALTER H=32 sp.3 cod. G2042.32N-3T45SX-P
+INSERTI-INSERTS-EINLAGEN cod. SX-3E300N02-CE4 WSM33S (10pz.) + CHIAVE-KEY cod. FS1494
- LAMA-BLADE-KLINGE WALTER H=32 sp.4 cod. G2042.32N-4T50SX-P
+INSERTI-INSERTS-EINLAGEN cod. SX-4E400N02-CE4 WSM33S (10pz.) + CHIAVE-KEY cod. FS1494

Cod. MT		N°Utensili N°Tools N°Werkzeuge	Reversibile lato mandrino/contromandrino Reversible sub/main spindle side Umkehrbare Spindelseite/ Gegenspindelseite	Lubr.esterna Ext. coolant Aussenkuehlung	Lubr.interna Coolant through Innenkuehlung
versione dx right version version rechts	versione sx left version version links				
NKM1110132R	NKM1110132L	1	X	X	P=70bar

NAKAMURA-TOME
 WT150/250 - WT15011/25011 - WTW150 - WTS150 - SUPER NTM3 - SUPER NTJ - SUPER NTJX - SC150/200/250
 NTY3 150/250 - TW10M/MY/MM/MMY/MMYY-TW20M/MY/MM/MMY/MMYY 16 ST. - WY150/250 - AS200 15/24 ST.

PORTAUTENSILE RADIALE PER LAMA CON LUBRIFICAZIONE INTERNA
 Radial blade holder with internal coolant
 Radial Abstechhalter mit Innenkuehlung

Subject to change without notice.

PRODUZIONE MODULI ROTANTI

M.T. srl
 Via Casino Albini 480
 Tel. 0541/956034-957884
 Fax 0541/956341
 47842 S. GIOVANNI IN M. (RN)
 e-mail: mtma@mtmarchetti.com
 http://www.mtmarchetti.com

PRODUZIONE MODULI ROTANTI



PAGINA NKM520-2-05

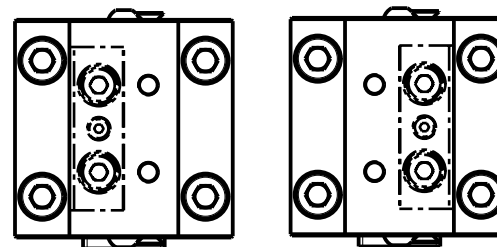
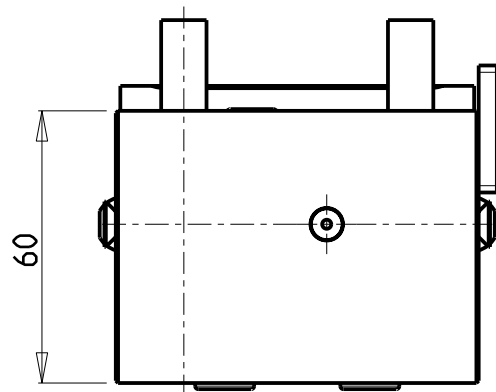
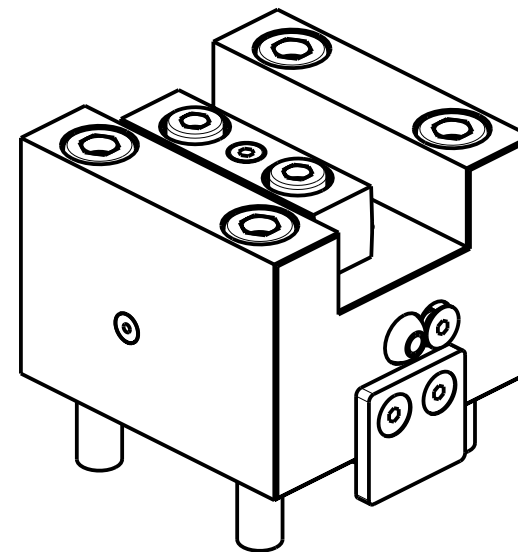
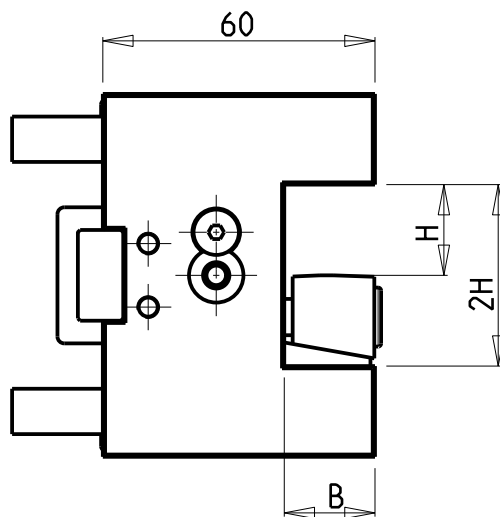
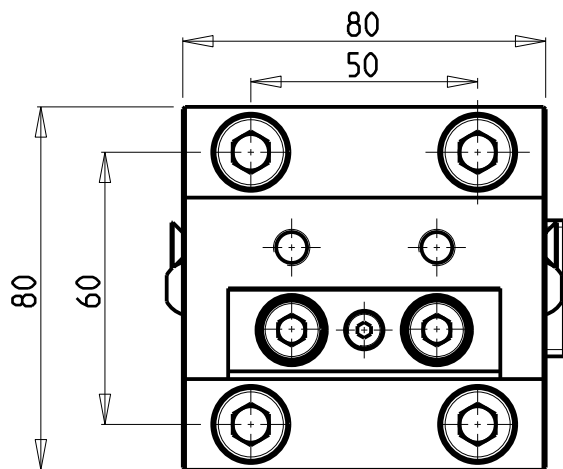

Cod. MT	Cod. NAKAMURA	N°utensili N°Tools N°Werkzeuge	Reversibile lato mandrino/contromandrino Reversible sub/main spindle side Umkehrbare Spindelseite/ Gegenspindelseite	Misure Dimensions Masse	B	H
NKM0182000	W 14 15	1	X	mm	20	20
NKM0181905	W 14 25	1	X	Inch	3/4"	3/4"

NAKAMURA - TOME

WT150/250 - WT15011/25011 - WTW150 - WTS150 - SUPER NTM3 - SUPER NTJ - SUPER NTJX - SC150/200/250
 NTY3 150/250 - TW10M/MY/MM/MMY/MMYY-TW20M/MY/MM/MMY/MMYY 16 ST. - WY 150/250 - AS200 15/24 ST.

PORTAUTENSILE ASSIALE SINGOLO QD=20mm / QD=3/4"

Axial single static tool QD=20mm / QD=3/4"

Axial Single-Werkzeughalter QD=20mm / QD=3/4"

Subject to change without notice.

M.T. srl

Via Casino Albini 480
 Tel. 0541/956034-957884
 Fax 0541/956341

47842 S. GIOVANNI IN M. (RN)
 e-mail: mtma@mtmarchetti.com
 http://www.mtmarchetti.com

PRODUZIONE MODULI ROTANTI



PAGINA NKM550-2-00

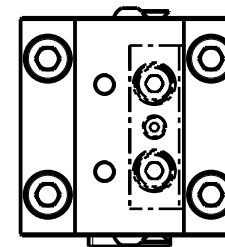
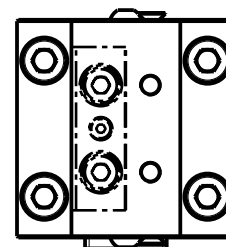
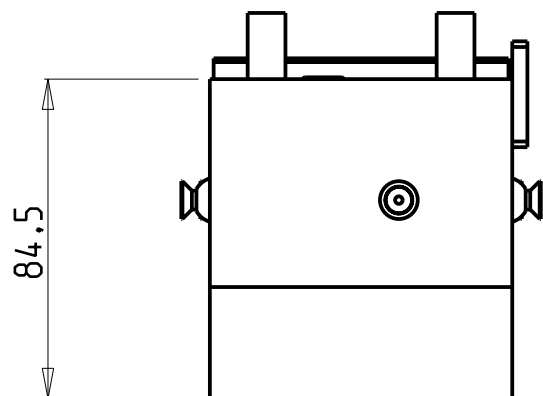
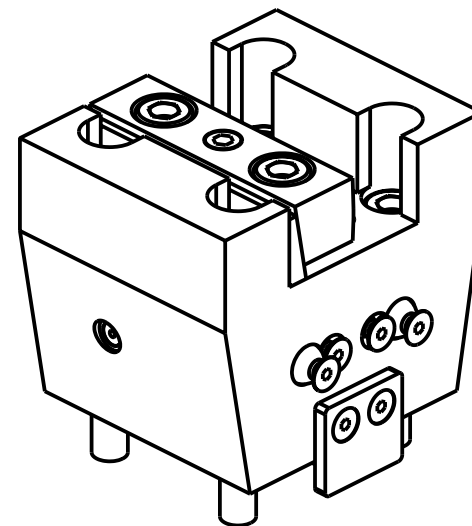
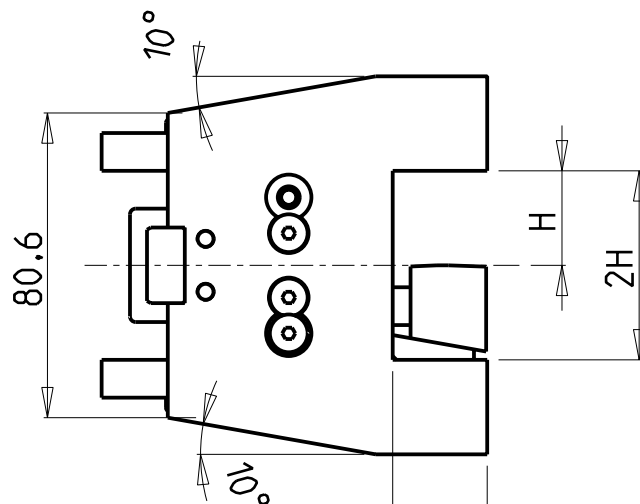
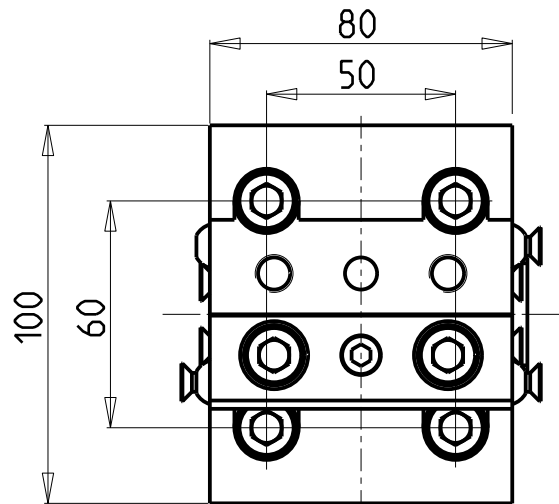

Cod. MT	N°Utensili N° Tools N° Werkzeuge	Reversibile lato mandrino/contromandrino Reversible sub/main spindle side Umkehrbare Spindel-seite/ Gegenspindel-seite	Lubrificazione est. Ext. coolant Aussenkuehlung	Misure Dimensions Masse	B	H
NKM0182500	1	X	X	mm	25	25

NAKAMURA-TOME

WT150/250 - WT15011/25011 - WTW150 - WTS150 - SUPER NTM3 - SUPER NTJ - SUPER NTJX - SC150/200/250
 NTY3 150/250 - TW10M/MY/MM/MMY/MMYY-TW20M/MY/MM/MMY/MMYY 16 ST. - WY 150/250 - AS200 15/24 ST.

PORTAUTENSILE ASSIALE SINGOLO QD=25mm

Axial single static tool QD=25mm

Axial Single-Werkzeughalter QD=25mm

Subject to change without notice.

M.T. srl

Via Casino Albini 480
 Tel. 0541/956034-957884
 Fax 0541/956341
 47842 S. GIOVANNI IN M. (RN)
 e-mail: mtma@mtmarchetti.com
 http://www.mtmarchetti.com

PRODUZIONE MODULI ROTANTI



PAGINA NKM552-2-00

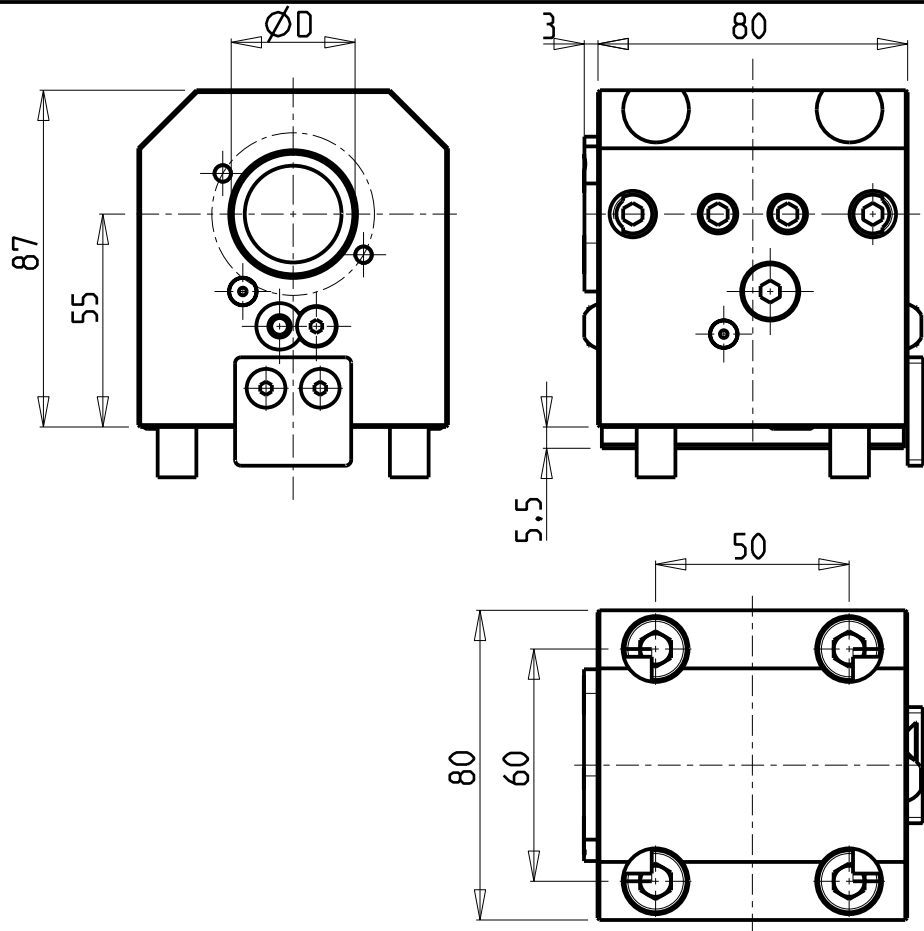

KIT ADDUZIONE INTERNA (OPZIONALE)
 KIT FOR INTERNAL COOLANT (OPTIONAL)
 KIT FUER INTERNE KUEHLMITTELZUFUHR (OPTIONAL)
 Ø32-Ø1 1/4" cod. KIT1000001

PER BOCCOLE DI RIDUZIONE VEDI PAG. TBL150-1-00
 FOR REDUCING BUSHINGS SEE PAGE TBL150-1-00
 FÜR REDUZIERBUCHSE SIEHE SEITE TBL150-1-00

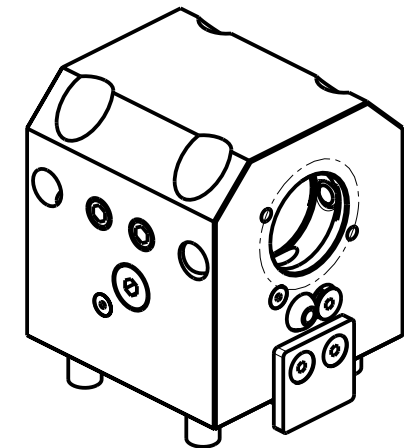

Cod. MT	N°Utensili N°Tools N°Werkzeuge	Reversibile lato mandrino/contromandrino Reversible sub/main spindle side Umkehrbare Spindel-seite/ Gegenspindel-seite	Lubrificazione int. opzionale Coolant through optional Innenkuehlung Optional	Lubrificazione est. Ext. coolant Aussenkuehlung	Misure Dimensions Masse	D
NKM0113220	1	X	X	X	mm	32
NKM0113230	1	X	X	X	Inch	1 1/4"

NAKAMURA-TOME

WT150/250 - WT15011/25011 - WTW150 - WTS150 - SUPER NTM3 - SUPER NTJ - SC150/200/250
 NTY3 150/250 - TW10M/MY/MM/MYY/MYY - TW20M/MY/MM/MYY/MYY 16 ST. - WY150/250 - AS200 15/24 ST.

PORTAUTENSILE ASSIALE PER BARENO Ø32mm / Ø1 1/4" H=55mm

Axial single boring bar holder Ø32mm / Ø1 1/4" H=55mm

Axial Bohrhälter Ø32mm / Ø1 1/4" H=55mm

Subject to change without notice.

M.T. srl

Via Casino Albini 480
 Tel. 0541/956034-957884
 Fax 0541/956341
 47842 S. GIOVANNI IN M. (RN)
 e-mail: mtma@mtmarchetti.com
 http://www.mtmarchetti.com

PRODUZIONE MODULI ROTANTI



PAGINA NKM650-2-10

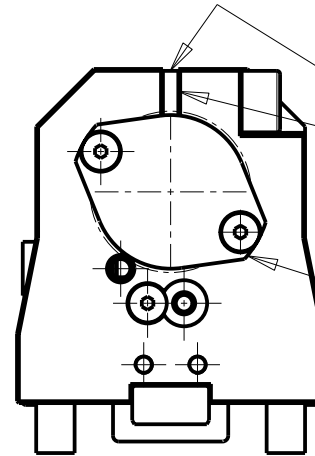
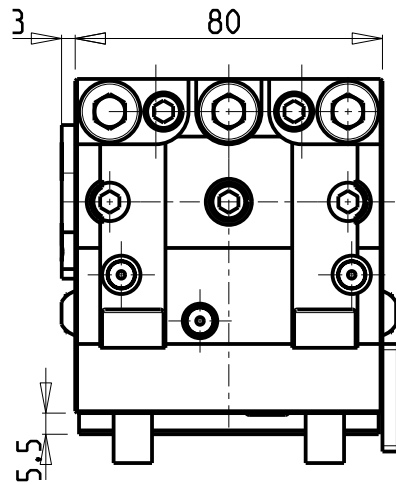
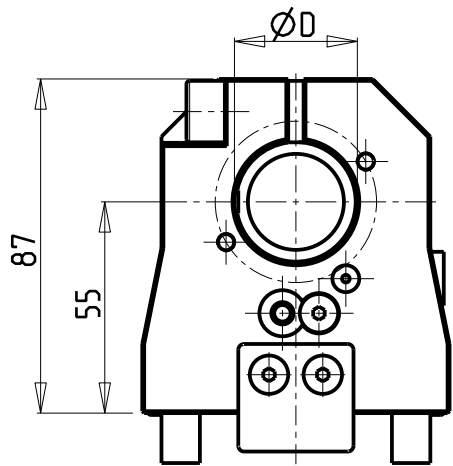

SOLO GUARNIZIONE (OPZIONALE)
 ONLY SEAL (OPTIONAL)
 NUR DICHTUNG (OPTIONAL)
 cod. NKM0110009

KIT ADDUZIONE INTERNA (OPZIONALE)
 KIT FOR INTERNAL COOLANT (OPTIONAL)
 KIT FUER INTERNE KUEHLMITTELZUFUHR (OPTIONAL)
 Ø32-Ø1 1/4" cod. KIT1004001

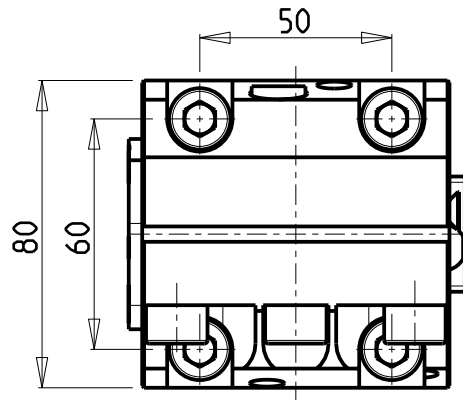

PER BOCCOLE DI RIDUZIONE VEDI PAG. TBL150-1-00
 FOR REDUCING BUSHINGS SEE PAGE TBL150-1-00
 FÜR REDUZIERBUCHSE SIEHE SEITE TBL150-1-00

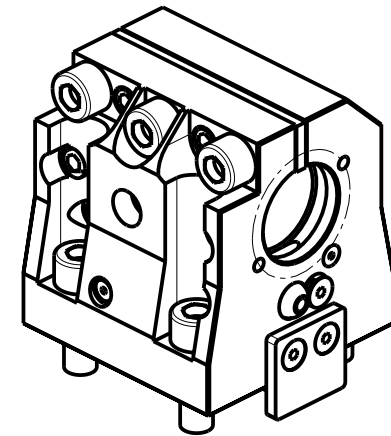

Cod. MT	N°Utensili N°Tools N°Werkzeuge	Reversibile lato mandrino/contromandrino Reversible sub/main spindle side Umkehrbare Spindel-seite/ Gegenspindel-seite	Lubrificazione int. opzionale Coolant through optional Innenkuehlung Optional	Lubrificazione est. Ext. coolant Aussenkuehlung	Misure Dimensions Masse	D
NKM0113221	1	X	X	X	mm	32
NKM0113231	1	X	X	X	Inch	1 1/4"

NAKAMURA-TOME

WT150/250 - WT15011/25011 - WTW150 - WTS150 - SUPER NTM3 - SUPER NTJ - SC150/200/250
 NTY3 150/250 - TW10M/MY/MM/MMY/MMYY-TW20M/MY/MM/MMY/MMYY 16 ST. - WY 150/250 - AS200 15/24 ST.

PORTAUTENSILE ASSIALE PER BARENO Ø32mm / Ø1 1/4" H=55mm
 Axial single boring bar holder Ø32mm / Ø1 1/4" H=55mm
 Axial Bohrhalter Ø32mm / Ø1 1/4" H=55mm

Subject to change without notice.

M.T. srl
 Via Casino Albini 480
 Tel. 0541/956034-957884
 Fax 0541/956341
 47842 S. GIOVANNI IN M. (RN)
 e-mail: mtma@mtmarchetti.com
 http://www.mtmarchetti.com

PRODUZIONE MODULI ROTANTI



PAGINA NKM650-2-20

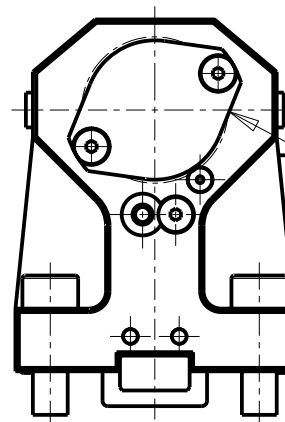
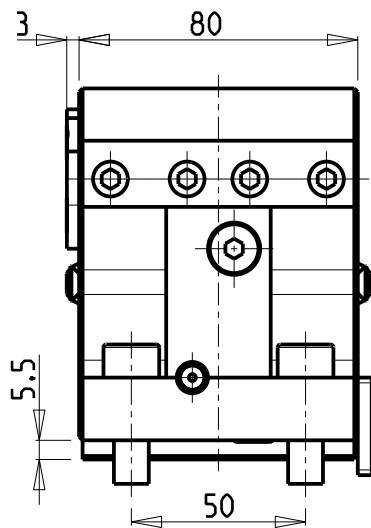
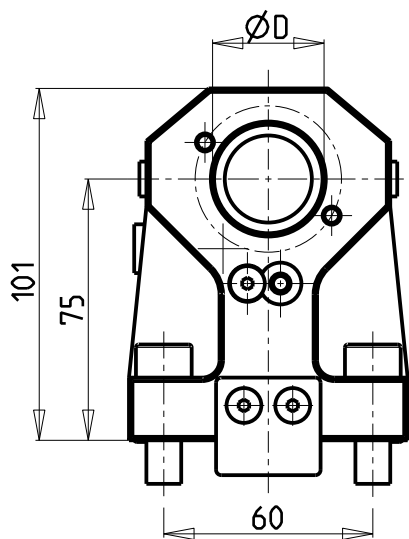

KIT ADDUZIONE INTERNA (OPZIONALE)
 KIT FOR INTERNAL COOLANT (OPTIONAL)
 KIT FUER INTERNE KUEHLMITTELZUFUHR (OPTIONAL)
 Ø32-Ø1 1/4" cod. KIT1000001
 Ø40 cod. KIT1000018

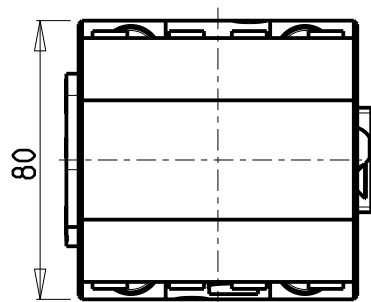

PER BOCCOLE DI RIDUZIONE VEDI PAG. TBL150-1-00
 FOR REDUCING BUSHINGS SEE PAGE TBL150-1-00
 FÜR REDUZIERBUCHSE SIEHE SEITE TBL150-1-00

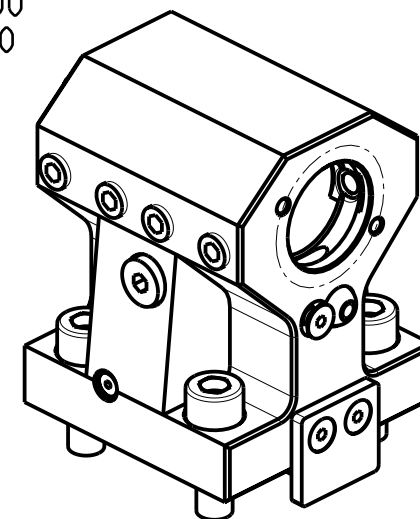

Cod. MT	N°Utensili N°Tools N°Werkzeuge	Reversibile lato mandrino/contromandrino Reversible sub/main spindle side Umkehrbare Spindel-seite/ Gegenspindel-seite	Lubrificazione int. opzionale Coolant through optional Innenkuehlung Optional	Lubrificazione est. Ext. coolant Aussenkuehlung	Misure Dimensions Masse	D
NKM0114000	1	X	X	X	mm	40
NKM0113200	1	X	X	X	mm	32
NKM0113210	1	X	X	X	Inch	1 1/4"

NAKAMURA-TOME

WT150/250 - WT15011/25011 - WTW150 - WTS150 - SUPER NTM3 - SUPER NTJ - SUPER NTJX - SC150/200/250
 NTY3 150/250 - TW10M/MY/MM/MMY/MMYY-TW20M/MY/MM/MMY/MMYY 16 ST. - AS200 15 ST.

PORTAUTENSILE ASSIALE PER BARENO Ø40mm / Ø32mm / Ø1 1/4" H=75 mm

Axial single boring bar holder Ø40mm / Ø32mm / Ø1 1/4" H=75mm

Axial Bohrhälter Ø40mm / Ø32mm / Ø1 1/4" H=75mm

Subject to change without notice.

M.T. srl

Via Casino Albini 480
 Tel. 0541/956034-957884
 Fax 0541/956341

47842 S. GIOVANNI IN M. (RN)
 e-mail: mtma@mtmarchetti.com
 http://www.mtmarchetti.com

PRODUZIONE MODULI ROTANTI



PAGINA NKM660-2-10

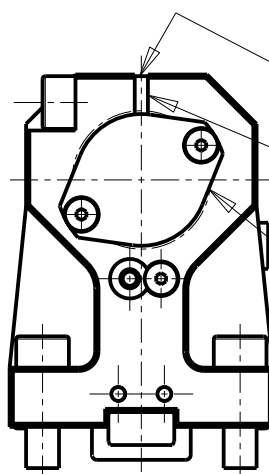
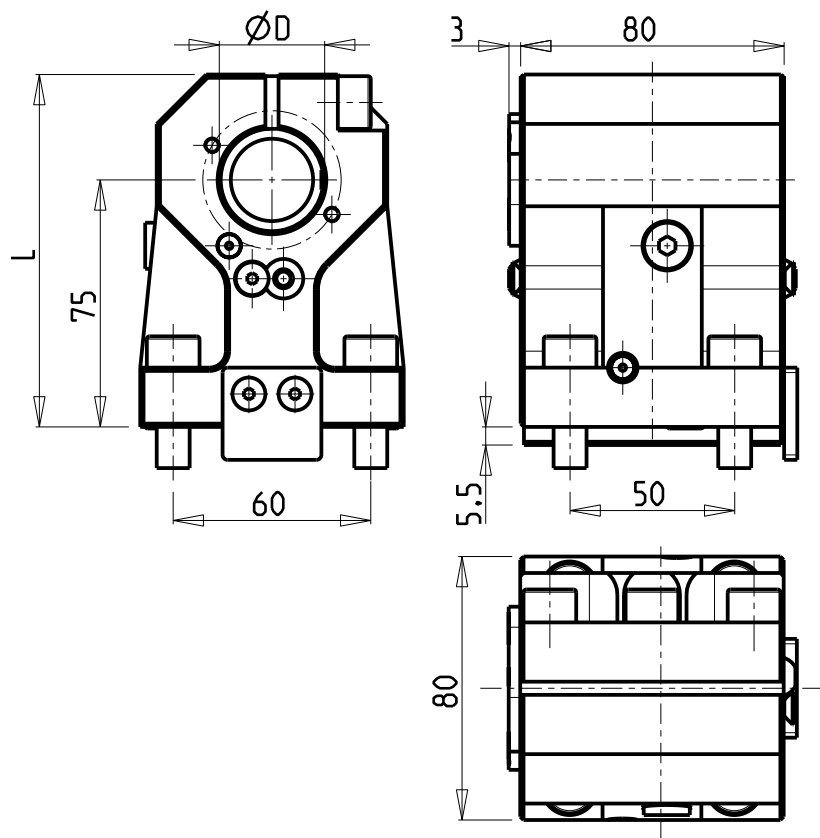

SOLO GUARNIZIONE (OPZIONALE)
 ONLY SEAL (OPTIONAL)
 NUR DICHTUNG (OPTIONAL)
 cod. NKM0110009

KIT ADDUZIONE INTERNA (OPZIONALE)
 KIT FOR INTERNAL COOLANT (OPTIONAL)
 KIT FUER INTERNE KUEHLMITTELZUFUHR (OPTIONAL)
 Ø32-Ø1 1/4" cod. KIT1004001
 Ø40 cod. KIT1004018
 Ø1 1/2" cod. KIT1004021

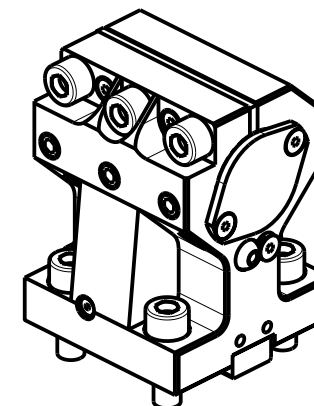

PER BOCCOLE DI RIDUZIONE VEDI PAG. TBL150-1-00
 FOR REDUCING BUSHINGS SEE PAGE TBL150-1-00
 FÜR REDUZIERBUCHSE SIEHE SEITE TBL150-1-00

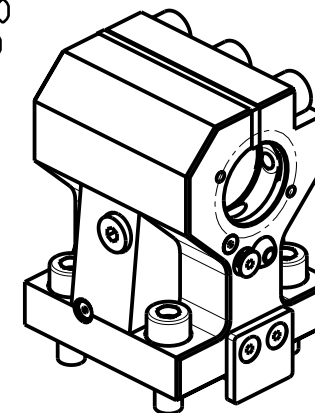

Cod. MT	Reversibile lato mandrino/contromandrino Reversible sub/main spindle side Umkehrbare Spindel-seite/ Gegenspindel-seite	Lubrificazione int. opzionale Coolant through optional Innenkuehlung Optional	Lubrificazione est. Ext. coolant Aussenkuehlung	D	L
NKM0114010	X	X	X	40	111
NKM0114030	X	X	X	1 1/2"	111
NKM0113201	X	X	X	32	107
NKM0113211	X	X	X	1 1/4"	107

NAKAMURA-TOME

WT250 - WT15011/25011 - WTW150 - WTS150 - SC150/200/250 - SUPER NTJX - NTY3 150/250

PORTAUTENSILE ASSIALE PER BARENO Ø40mm / Ø1 1/2" / Ø32mm / Ø1 1/4" H=75mm

Axial single boring bar holder Ø40mm / Ø1 1/2" / Ø32mm / Ø1 1/4" H=75mm

Axial Bohrhälter Ø40mm / Ø1 1/2" / Ø32mm / Ø1 1/4" H=75mm

Subject to change without notice.

M.T. srl

Via Casino Albini 480
 Tel. 0541/956034-957884
 Fax 0541/956341

47842 S. GIOVANNI IN M. (RN)
 e-mail: mtma@mtmarchetti.com
 http://www.mtmarchetti.com

PRODUZIONE MODULI ROTANTI



PAGINA NKM660-2-20

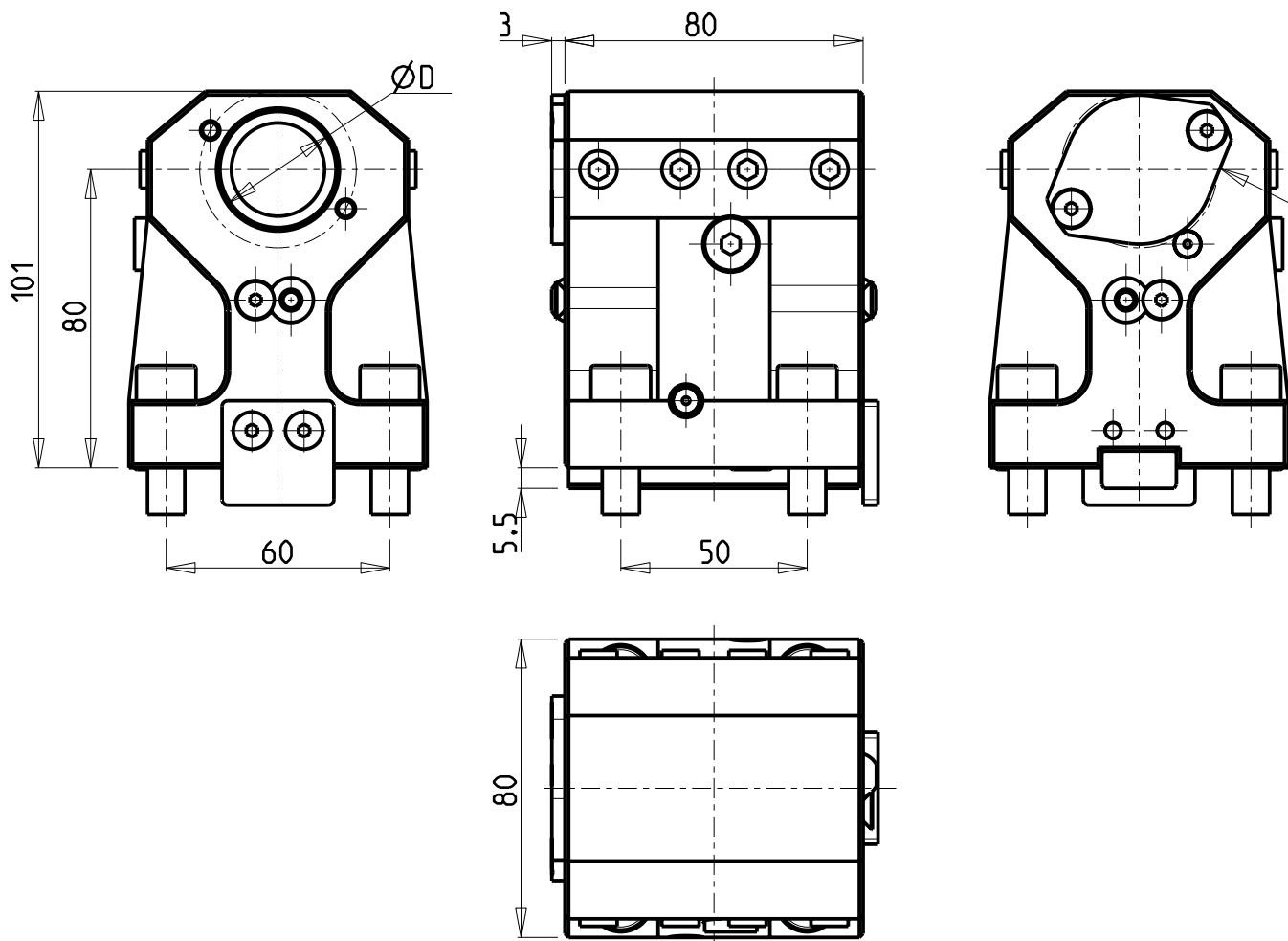

KIT ADDUZIONE INTERNA (OPZIONALE)
 KIT FOR INTERNAL COOLANT (OPTIONAL)
 KIT FUER INTERNE KUEHLMITTELZUFUHR (OPTIONAL)
 Ø32-Ø1 1/4" cod. KIT1000001

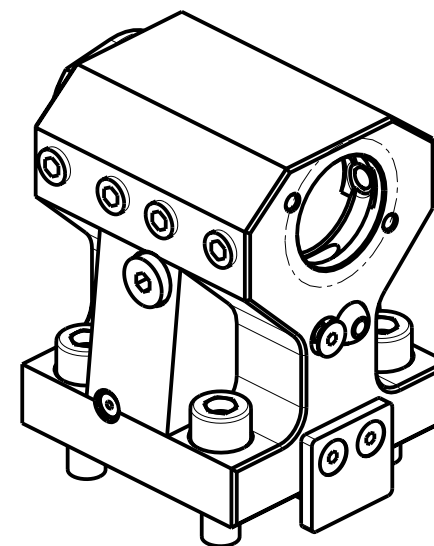

Cod. MT	N°Utensili N°Tools N°Werkzeuge	Reversibile lato mandrino/contromandrino Reversible sub/main spindle side Umkehrbare Spindel-seite/ Gegenspindel-seite	Lubrificazione int. opzionale Coolant through optional Innenkuehlung Optional	Lubrificazione est. Ext. coolant Aussenkuehlung	Misure Dimensions Masse	D
NKM0113240	1	X	X	X	mm	32

PER BOCCOLE DI RIDUZIONE VEDI PAG. TBL150-1-00
 FOR REDUCING BUSHINGS SEE PAGE TBL150-1-00
 FÜR REDUZIERBUCHSE SIEHE SEITE TBL150-1-00

NAKAMURA-TOME

WT150/250 - WT15011/25011 - WTW150 - WTS150 - SUPER NTM3 - SUPER NTJ - SUPER NTJX - SC150/200/250
 NTY3 150/250 - TW10M/MY/MM/MMY/MMYY-TW20M/MY/MM/MMY/MMYY 16 ST. - AS200 15 ST.

PORTAUTENSILE ASSIALE PER BARENO Ø32mm H=80mm

Axial single boring bar holder Ø32mm H=80mm

Axial Bohrhälter Ø32mm H=80mm

Subject to change without notice.

M.T. srl

Via Casino Albini 480
 Tel. 0541/956034-957884
 Fax 0541/956341
 47842 S. GIOVANNI IN M. (RN)
 e-mail: mtma@mtmarchetti.com
 http://www.mtmarchetti.com

PRODUZIONE MODULI ROTANTI



PAGINA NKM665-2-10

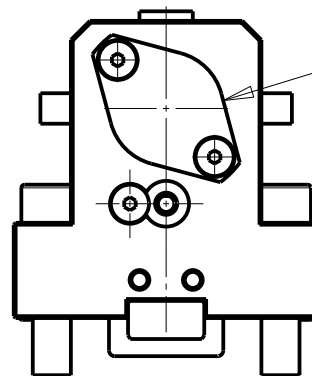
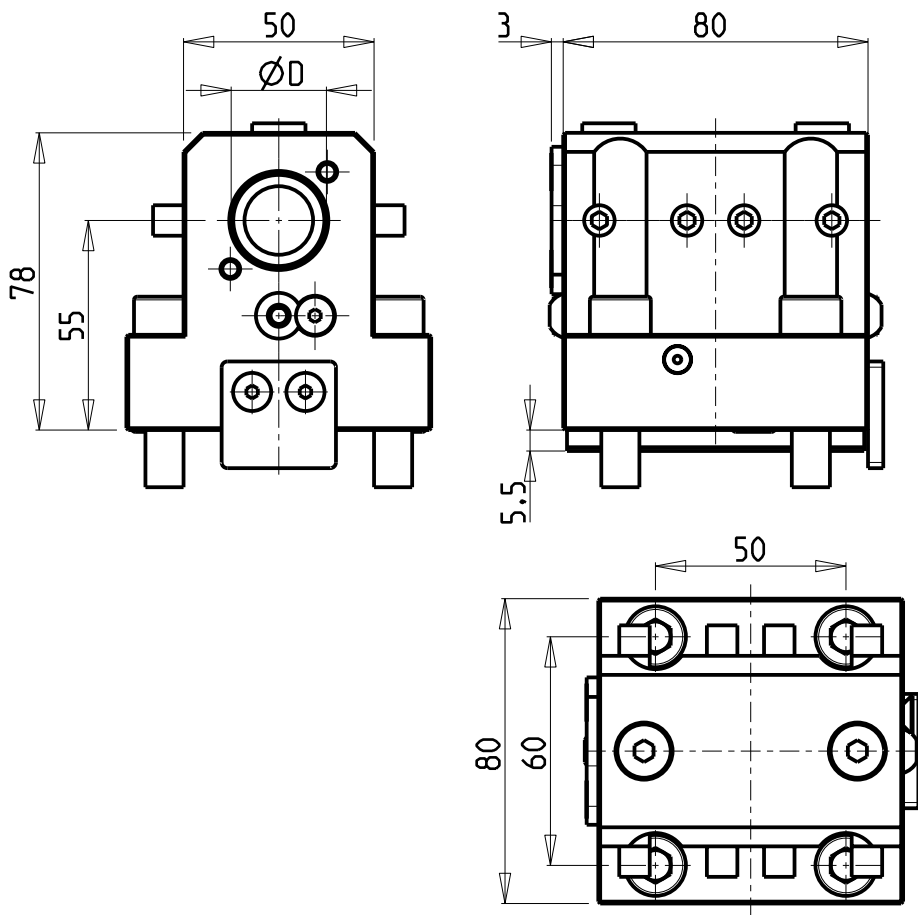

KIT ADDUZIONE INTERNA (OPZIONALE)
 KIT FOR INTERNAL COOLANT (OPTIONAL)
 KIT FUER INTERNE KUEHLMITTELZUFUHR (OPTIONAL)
 Ø25-Ø1" cod. KIT1000006

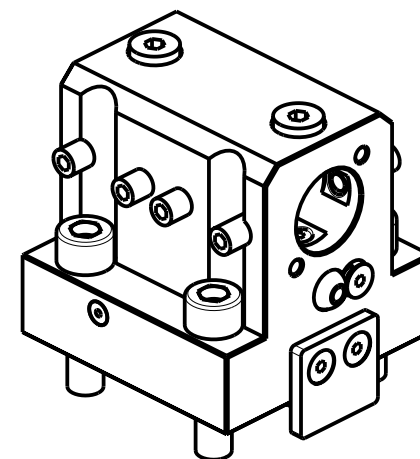

PER BOCCOLE DI RIDUZIONE VEDI PAG. TBL150-1-00
 FOR REDUCING BUSHINGS SEE PAGE TBL150-1-00
 FÜR REDUZIERBUCHSE SIEHE SEITE TBL150-1-00

Cod. MT	N°Utensili N° Tools N° Werkzeuge	Reversibile lato mandrino/contromandrino Reversible sub/main spindle side Umkehrbare Spindel-seite/ Gegenspindel-seite	Lubrificazione int. opzionale Coolant through optional Innenkuehlung Optional	Lubrificazione est. Ext. coolant Aussenkuehlung	Misure Dimensions Masse	D
NKM0112500	1	X	X	X	mm	25
NKM0112510	1	X	X	X	Inch	1"

NAKAMURA-TOME

WT150/250 - WT15011/25011 - WTW150 - WTS150 - SUPER NTM3 - SUPER NTJ - SC150/200/250
 NTY3 150/250 - TW10M/MY/MM/MMY/MMYY-TW20M/MY/MM/MMY/MMYY 16 ST. - WY 150/250 - AS200 15/24 ST.

PORTAUTENSILE ASSIALE PER BARENO Ø25mm / Ø1" H=55mm

Axial single boring bar holder Ø25mm / Ø1" H=55mm

Axial Bohrhälter Ø25mm / Ø1" H=55mm

Subject to change without notice.

M.T. srl

Via Casino Albini 480
 Tel. 0541/956034-957884
 Fax 0541/956341
 47842 S. GIOVANNI IN M. (RN)
 e-mail: mtma@mtmarchetti.com
 http://www.mtmarchetti.com

PRODUZIONE MODULI ROTANTI



PAGINA NKM670-2-10

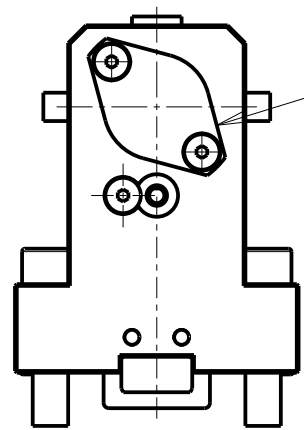
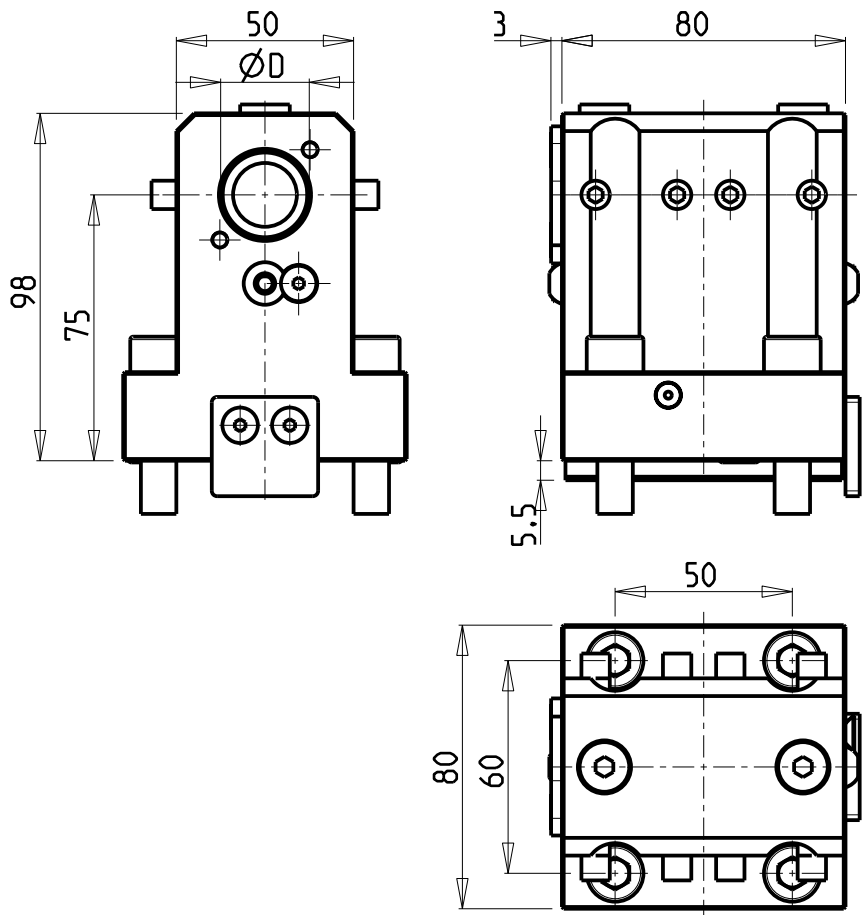

KIT ADDUZIONE INTERNA (OPZIONALE)
 KIT FOR INTERNAL COOLANT (OPTIONAL)
 KIT FUER INTERNE KUEHLMITTELZUFUHR (OPTIONAL)
 Ø25-Ø1" cod. KIT1000006

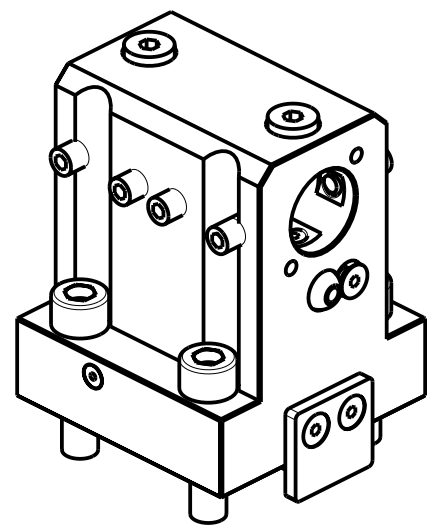

Cod. MT	Cod. NAKAMURA	N°Utensili N°Tools N°Werkzeuge	Reversibile lato mandrino/contromandrino Reversible sub/main spindle side Umkehrbare Spindel-seite/ Gegenspindel-seite	Lubrificazione int. opzionale Coolant through optional Innenkuehlung Optional	Lubrificazione est. Ext. coolant Aussenkuehlung	Misure Dimensions Masse	D
NKM0112520	W 4437	1	X	X	X	mm	25
NKM0112530	W 4447	1	X	X	X	Inch	1"

PER BOCCOLE DI RIDUZIONE VEDI PAG. TBL150-1-00
 FOR REDUCING BUSHINGS SEE PAGE TBL150-1-00
 FÜR REDUZIERBUCHSE SIEHE SEITE TBL150-1-00

NAKAMURA-TOME
 WT150/250 - WT15011/25011 - WTW150 - WTS150 - SUPER NTM3 - SUPER NTJ - SUPER NTJX - SC150/200/250
 NTY3 150/250 - TW10M/MY/MM/MMY/MMYY-TW20M/MY/MM/MMY/MMYY 16 ST. - AS200 15 ST.

PORTAUTENSILE ASSIALE PER BARENO Ø25mm / Ø1" H=75mm
 Axial single boring bar holder Ø25mm / Ø1" H=75mm
 Axial Bohrhälter Ø25mm / Ø1" H=75mm

Subject to change without notice.

M.T. srl
 Via Casino Albini 480
 Tel. 0541/956034-957884
 Fax 0541/956341
 47842 S. GIOVANNI IN M. (RN)
 e-mail: mtma@mtmarchetti.com
 http://www.mtmarchetti.com

PRODUZIONE MODULI ROTANTI



PAGINA NKM680-2-10

KIT ADDUZIONE INTERNA (OPZIONALE)
 KIT FOR INTERNAL COOLANT (OPTIONAL)
 KIT FUER INTERNE KUEHLMITTELZUFUHR (OPTIONAL)
 Ø32 cod. KIT1000001

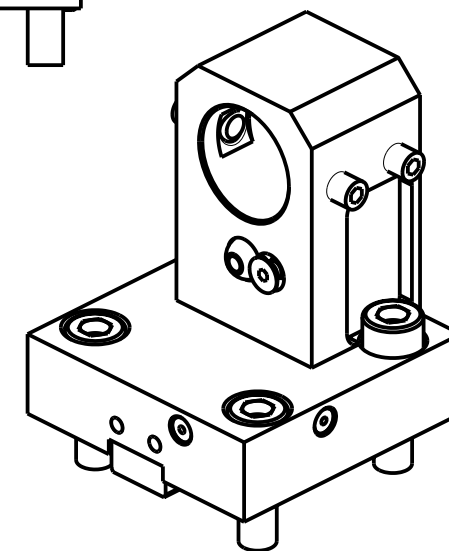
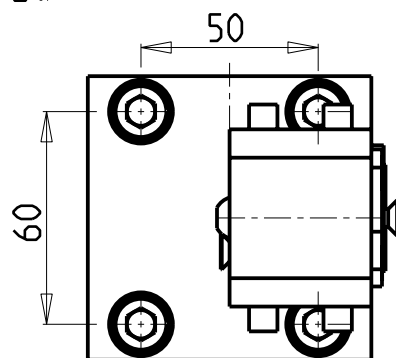
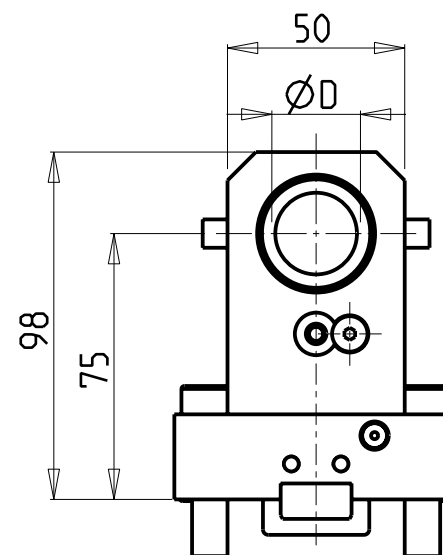
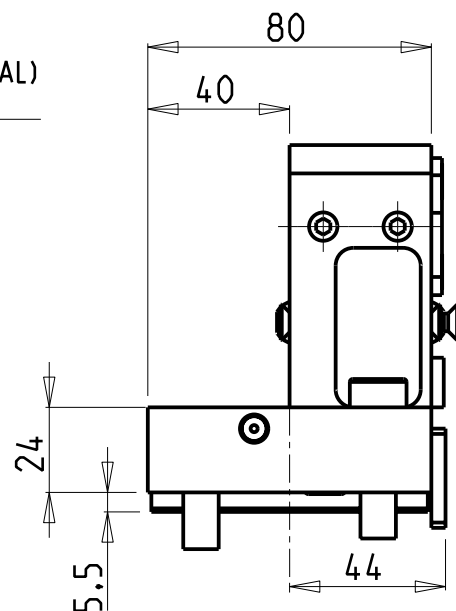
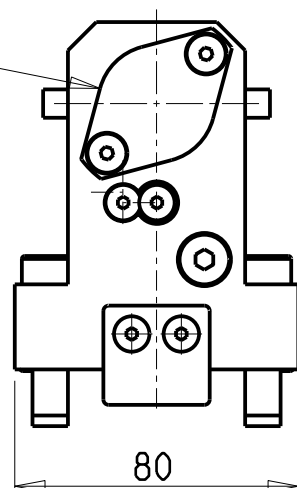

PER BOCCOLE DI RIDUZIONE VEDI PAG. TBL150-1-00
 FOR REDUCING BUSHINGS SEE PAGE TBL150-1-00
 FÜR REDUZIERBUCHSE SIEHE SEITE TBL150-1-00

Cod. MT	N°Utensili N°Tools N°Werkzeuge	Reversibile lato mandrino/contromandrino Reversible sub/main spindle side Umkehrbare Spindel-seite/ Gegenspindel-seite	Lubrificazione int. opzionale Coolant through optional Innenkuehlung Optional	Lubrificazione est. Ext. coolant Aussenkuehlung	Misure Dimensions Masse	D
NKM1363200	1	X	X	X	mm	32

NAKAMURA-TOME

WT150/250 - WT15011/25011 - WTW150 - WTS150 - SUPER NTM3 - SUPER NTJ - SUPER NTJX - SC150/200/250
 NTY3 150/250 - TW10M/MY/MM/MMY/MMYY-TW20M/MY/MM/MMY/MMYY 16 ST. - AS200 15 ST.

PORTAUTENSILE ASSIALE ARRETRATO PER BARENO Ø32mm H=75mm

Axial single rear set boring bar holder Ø32mm H=75mm

Axial Bohrhälter zurueckversetzt Ø32mm H=75mm

Subject to change without notice.

M.T. srl

Via Casino Albini 480
 Tel. 0541/956034-957884
 Fax 0541/956341
 47842 S. GIOVANNI IN M. (RN)
 e-mail: mtma@mtmarchetti.com
 http://www.mtmarchetti.com

PRODUZIONE MODULI ROTANTI



PAGINA NKM847-2-10

KIT ADDUZIONE INTERNA (OPZIONALE)
 KIT FOR INTERNAL COOLANT (OPTIONAL)
 KIT FUER INTERNE KUEHLMITTELZUFUHR (OPTIONAL)
 Ø25 cod. KIT1000006

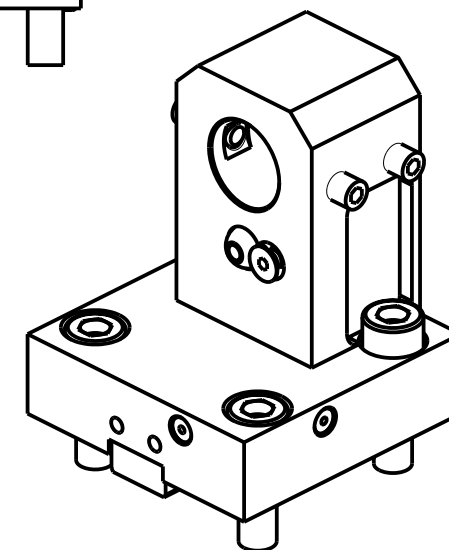
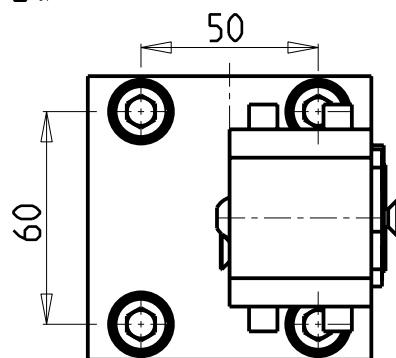
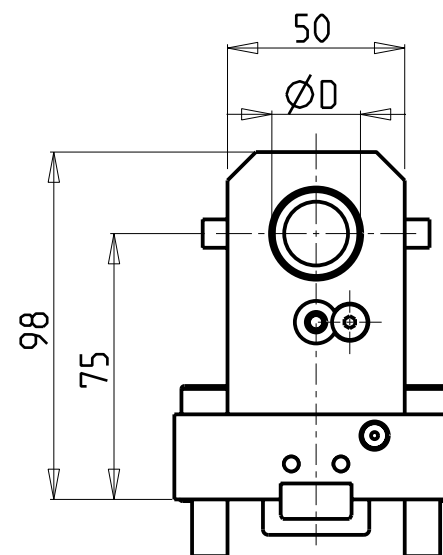
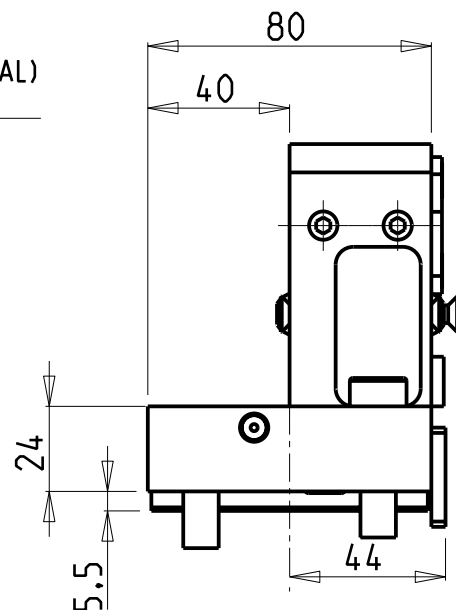
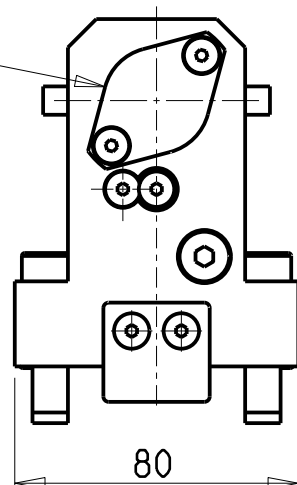

PER BOCCOLE DI RIDUZIONE VEDI PAG. TBL150-1-00
 FOR REDUCING BUSHINGS SEE PAGE TBL150-1-00
 FÜR REDUZIERBUCHSE SIEHE SEITE TBL150-1-00

Cod. MT	N°Utensili N°Tools N°Werkzeuge	Reversibile lato mandrino/contromandrino Reversible sub/main spindle side Umkehrbare Spindel-seite/ Gegenspindel-seite	Lubrificazione int. opzionale Coolant through optional Innenkuehlung Optional	Lubrificazione est. Ext. coolant Aussenkuehlung	Misure Dimensions Masse	D
NKM1362500	1	X	X	X	mm	25

NAKAMURA-TOME

WT150/250 - WT15011/25011 - WTW150 - WTS150 - SUPER NTM3 - SUPER NTJ - SUPER NTJX - SC150/200/250
 NTY3 150/250 - TW10M/MY/MM/MMY/MMYY-TW20M/MY/MM/MMY/MMYY 16 ST. - AS200 15 ST.

PORTAUTENSILE ASSIALE ARRETRATO PER BARENO Ø25mm H=75mm

Axial single rear set boring bar holder Ø25mm H=75mm

Axial Bohrhälter zurueckversetzt Ø25mm H=75mm

Subject to change without notice.

M.T. srl

Via Casino Albini 480
 Tel. 0541/956034-957884
 Fax 0541/956341
 47842 S. GIOVANNI IN M. (RN)
 e-mail: mtma@mtmarchetti.com
 http://www.mtmarchetti.com

PRODUZIONE MODULI ROTANTI



PAGINA NKM848-2-10

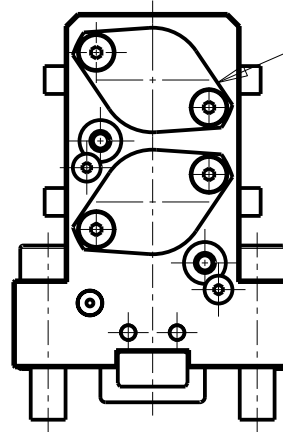
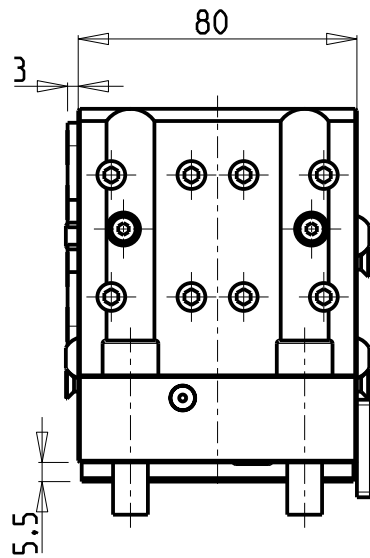
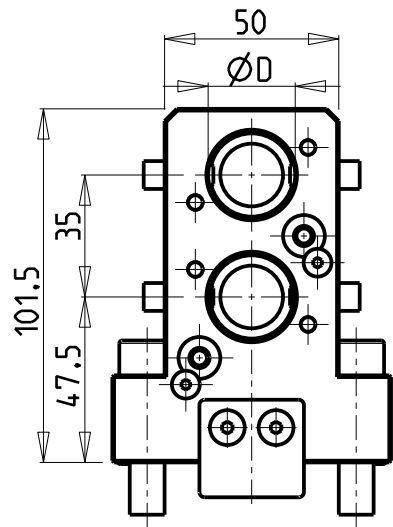

KIT ADDUZIONE INTERNA (OPZIONALE)
 KIT FOR INTERNAL COOLANT (OPTIONAL)
 KIT FUER INTERNE KUEHLMITTELZUFUHR (OPTIONAL)
 Ø25-Ø1" cod. KIT1000006

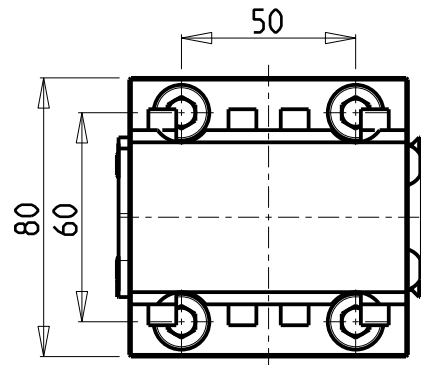
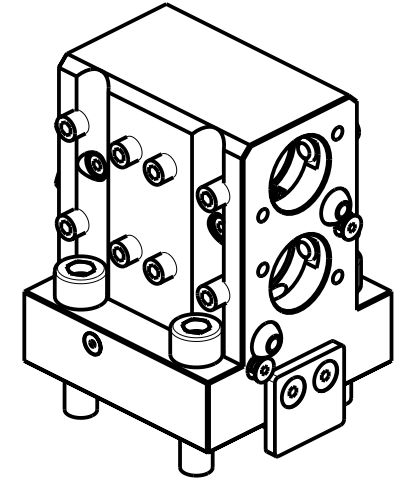

PER BOCCOLE DI RIDUZIONE VEDI PAG. TBL150-1-00
 FOR REDUCING BUSHINGS SEE PAGE TBL150-1-00
 FÜR REDUZIERBUCHSE SIEHE SEITE TBL150-1-00

Cod. MT	Cod. NAKAMURA	N°Utensili N°Tools N°Werkzeuge	Reversibile lato mandrino/contromandrino Reversible sub/main spindle side Umkehrbare Spindel-seite/ Gegenspindel-seite	Lubrificazione int. opzionale Coolant through optional Innenkuehlung Optional	Lubrificazione est. Ext. coolant Aussenkuehlung	Misure Dimensions Masse	D
NKM0142500	R8418	2	X	X	X	mm	25
NKM0142510	R8428	2	X	X	X	Inch	1"

NAKAMURA - TOME

WT150 - WT15011 - SUPER NTM3 - SC150/200/250
 TW10M/MY/MM/MYY/MMYY-TW20M/MY/MM/MYY/MMYY 16 ST. - AS200 15 ST.

PORTAUTENSILE ASSIALE PER BARENO 2 POSIZIONI Ø25mm / Ø1"

Axial double boring bar holder Ø25mm / Ø1"

Axial Bohrhälter 2 Positionen Ø25mm / Ø1"

Subject to change without notice.

M.T. srl

Via Casino Albini 480
 Tel. 0541/956034-957884
 Fax 0541/956341
 47842 S. GIOVANNI IN M. (RN)
 e-mail: mtma@mtmarchetti.com
 http://www.mtmarchetti.com

PRODUZIONE MODULI ROTANTI



PAGINA NKM864-2-00

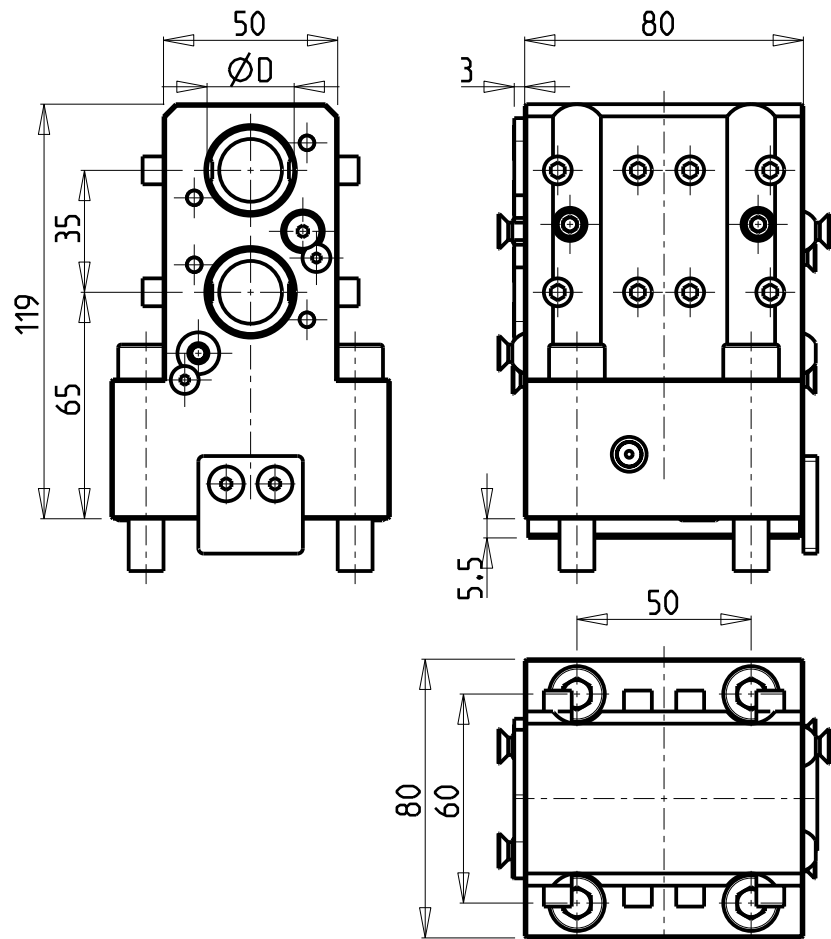

KIT ADDUZIONE INTERNA (OPZIONALE)
 KIT FOR INTERNAL COOLANT (OPTIONAL)
 KIT FUER INTERNE KUEHLMITTELZUFUHR (OPTIONAL)
 Ø25-Ø1" cod. KIT1000006

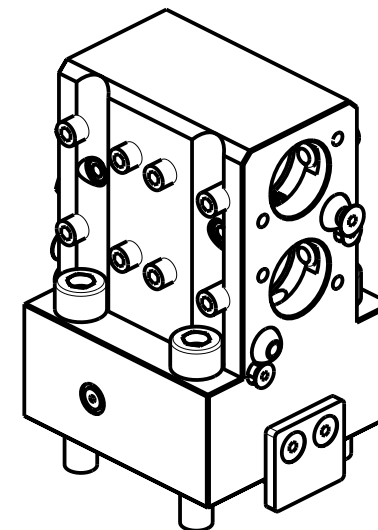
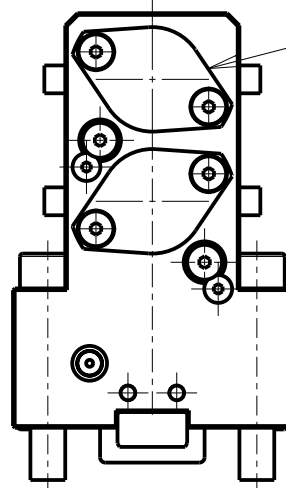

PER BOCCOLE DI RIDUZIONE VEDI PAG. TBL150-1-00
 FOR REDUCING BUSHINGS SEE PAGE TBL150-1-00
 FÜR REDUZIERBUCHSE SIEHE SEITE TBL150-1-00

Cod. MT	N°Utensili N° Tools N° Werkzeuge	Reversibile lato mandrino/controlmandrino Reversible sub/main spindle side Umkehrbare Spindel-seite/ Gegenspindel-seite	Lubrificazione int. opzionale Coolant through optional Innenkuehlung Optional	Lubrificazione est. Ext. coolant Aussenkuehlung	Misure Dimensions Masse	D
NKM0652500	2	X	X	X	mm	25
NKM0652540	2	X	X	X	Inch	1"

NAKAMURA-TOME

MOD: WTW150 - WTS150

PORTAUTENSILE ASSIALE PER BARENO 2 POSIZIONI Ø25mm / Ø1"

Axial double boring bar holder Ø25mm / Ø1"

Axial Bohrhalter 2 Positionen Ø25mm / Ø1"

Subject to change without notice.

M.T. srl

Via Casino Albini 480
 Tel. 0541/956034-957884
 Fax 0541/956341
 47842 S. GIOVANNI IN M. (RN)
 e-mail: mtma@mtmarchetti.com
 http://www.mtmarchetti.com

PRODUZIONE MODULI ROTANTI



PAGINA NKM864-2-10

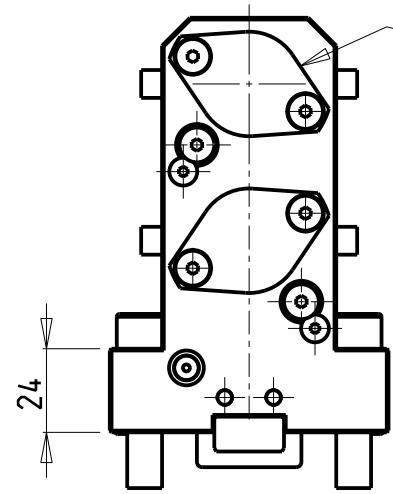
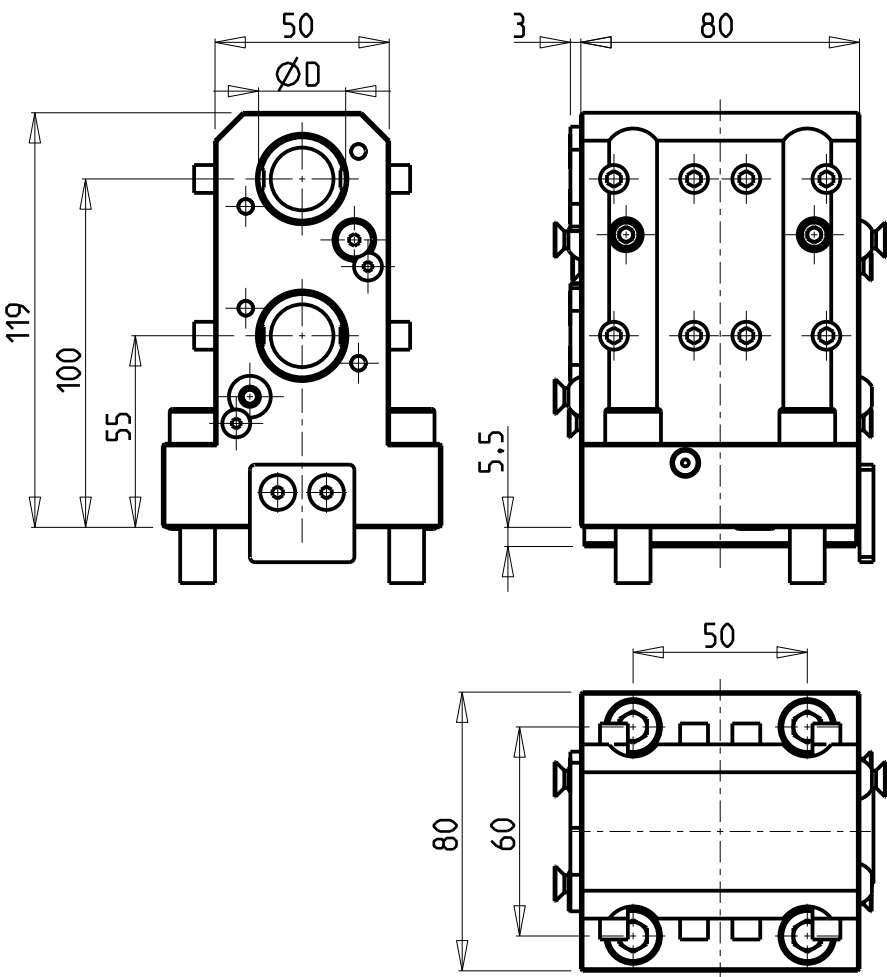

KIT ADDUZIONE INTERNA (OPZIONALE)
 KIT FOR INTERNAL COOLANT (OPTIONAL)
 KIT FUER INTERNE KUEHLMITTELZUFUHR (OPTIONAL)
 Ø25 cod. KIT1000006

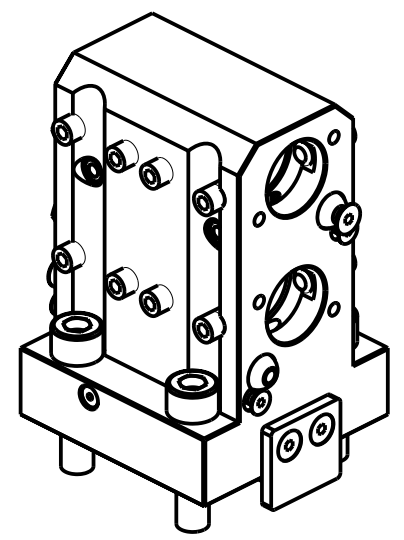

PER BOCCOLE DI RIDUZIONE VEDI PAG. TBL150-1-00
 FOR REDUCING BUSHINGS SEE PAGE TBL150-1-00
 FUR REDUZIERBUCHSE SIEHE SEITE TBL150-1-00

Cod. MT	N°Utensili N°Tools N°Werkzeuge	Reversibile lato mandrino/contromandrino Reversible sub/main spindle side Umkehrbare Spindel-seite/ Gegenspindel-seite	Lubrificazione int. opzionale Coolant through optional Innenkuehlung Optional	Lubrificazione est. Ext. coolant Aussenkuehlung	Misure Dimensions Masse	D
NKM1432500	2	X	X	X	mm	25

NAKAMURA-TOME

MOD: WT250 - WT25011

PORTAUTENSILE ASSIALE PER BARENO 2 POSIZIONI Ø25mm

Axial double boring bar holder Ø25mm

Axial Bohrhalter 2 Positionen Ø25mm

Subject to change without notice.

M.T. srl
 Via Casino Albini 480
 Tel. 0541/956034-957884
 Fax 0541/956341
 47842 S. GIOVANNI IN M. (RN)
 e-mail: mtma@mtmarchetti.com
 http://www.mtmarchetti.com

PRODUZIONE MODULI ROTANTI



PAGINA NKM864-2-20

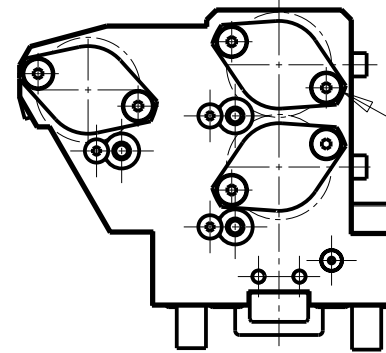
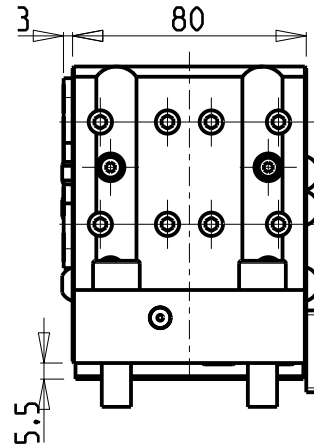
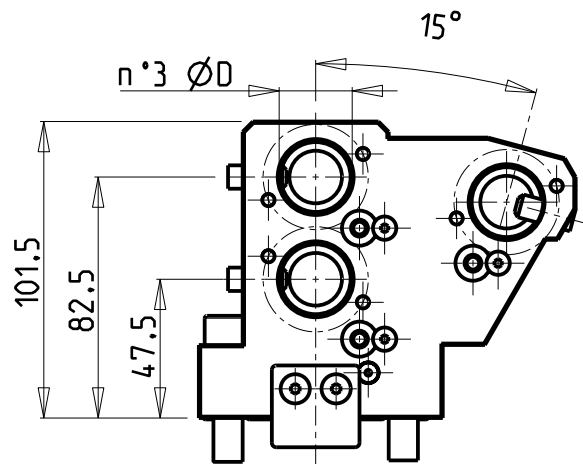

KIT ADDUZIONE INTERNA (OPZIONALE)
 KIT FOR INTERNAL COOLANT (OPTIONAL)
 KIT FUER INTERNE KUEHLMITTELZUFUHR (OPTIONAL)
 Ø25-Ø1" cod. KIT1000006

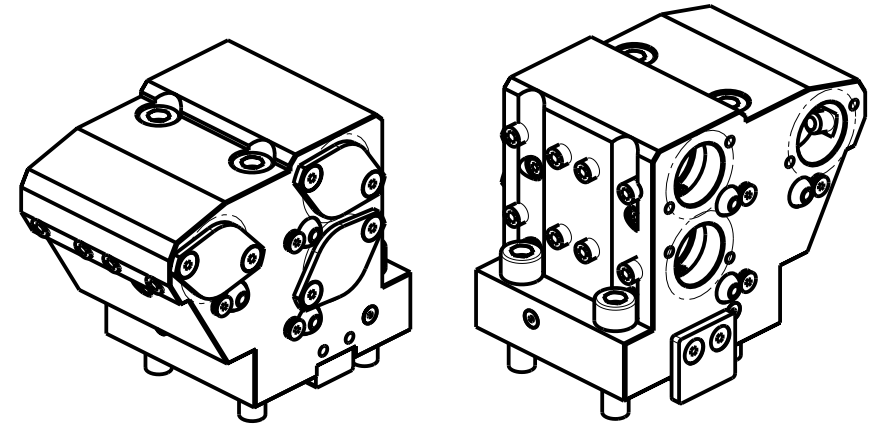
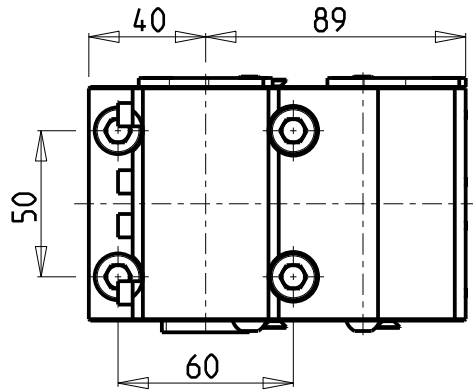

Cod. MT	N°Utensili N°Tools N°Werkzeuge	Reversibile lato mandrino/contromandrino Reversible sub/main spindle side Umkehrbare Spindel-seite/ Gegenspindel-seite	Lubrificazione int. opzionale Coolant through optional Innenkuehlung Optional	Lubrificazione est. Ext. coolant Aussenkuehlung	Misure Dimensions Masse	D
NKM0211000	3	X	X	X	mm	25
NKM0212540	3	X	X	X	Inch	1"

PER BOCCOLE DI RIDUZIONE VEDI PAG. TBL150-1-00
 FOR REDUCING BUSHINGS SEE PAGE TBL150-1-00
 FÜR REDUZIERBUCHSE SIEHE SEITE TBL150-1-00

NAKAMURA-TOME

MOD: WT150 - WT15011/25011 - SUPER NTM3 - NTY3 150/250 - SUPER NTJ - SC200 - WY150/250

PORTAUTENSILE ASSIALE PER BARENO 3 POSIZIONI Ø25mm / Ø1"

Axial 3 position boring bar holder Ø25mm / Ø1"

Axial Bohrhälter 3 Positionen Ø25mm / Ø1"

Subject to change without notice.

M.T. srl

Via Casino Albini 480
 Tel. 0541/956034-957884
 Fax 0541/956341
 47842 S. GIOVANNI IN M. (RN)
 e-mail: mtma@mtmarchetti.com
 http://www.mtmarchetti.com

PRODUZIONE MODULI ROTANTI



PAGINA NKM884-2-00

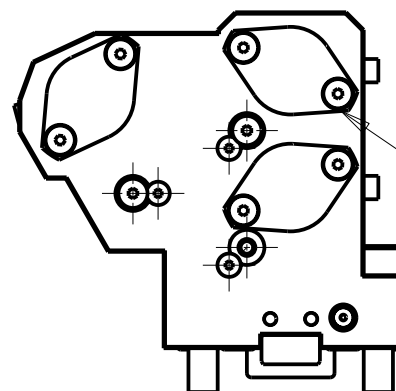
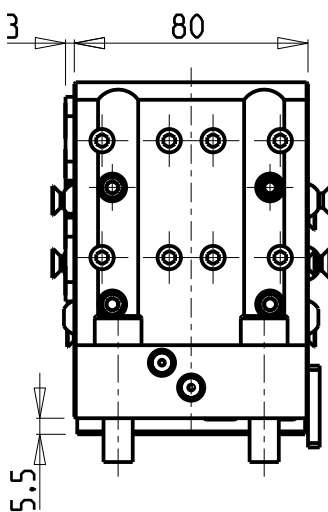
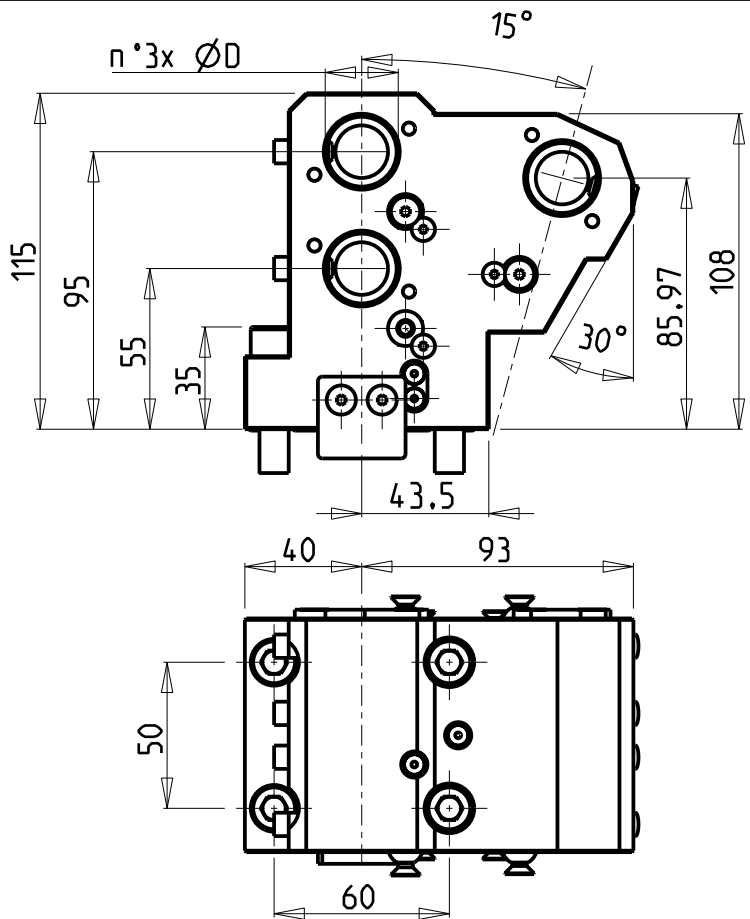

KIT ADDUZIONE INTERNA (OPZIONALE)
 KIT FOR INTERNAL COOLANT (OPTIONAL)
 KIT FUER INTERNE KUEHLMITTELZUFUHR (OPTIONAL)
 Ø25 cod. KIT1000006

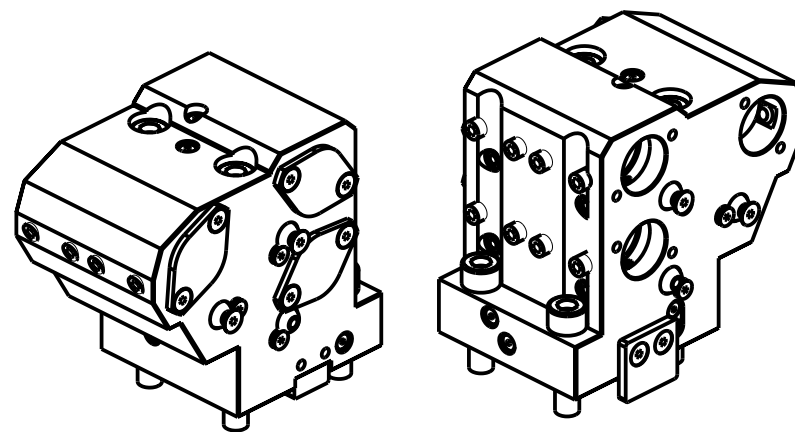

PER BOCCOLE DI RIDUZIONE VEDI PAG. TBL150-1-00
 FOR REDUCING BUSHINGS SEE PAGE TBL150-1-00
 FÜR REDUZIERBUCHSE SIEHE SEITE TBL150-1-00

Cod. MT	N°Utensili N°Tools N°Werkzeuge	Reversibile lato mandrino/contromandrino Reversible sub/main spindle side Umkehrbare Spindel-seite/ Gegenspindel-seite	Lubrificazione int. opzionale Coolant through optional Innenkuehlung Optional	Lubrificazione est. Ext. coolant Aussenkuehlung	Misure Dimensions Masse	D
NKM1422500	3	X	X	X	mm	25

NAKAMURA-TOME

MOD: WT250 - WT250II - NTY3 150/250 - SUPER NTJ

PORTAUTENSILE ASSIALE PER BARENO 3 POSIZIONI Ø25mm

Axial 3 position boring bar holder Ø25mm

Axial Bohrhälter 3 Positionen Ø25mm

Subject to change without notice.

M.T. srl

Via Casino Albini 480
 Tel. 0541/956034-957884
 Fax 0541/956341

47842 S. GIOVANNI IN M. (RN)
 e-mail: mtma@mtmarchetti.com
 http://www.mtmarchetti.com

PRODUZIONE MODULI ROTANTI



PAGINA NKM884-2-10

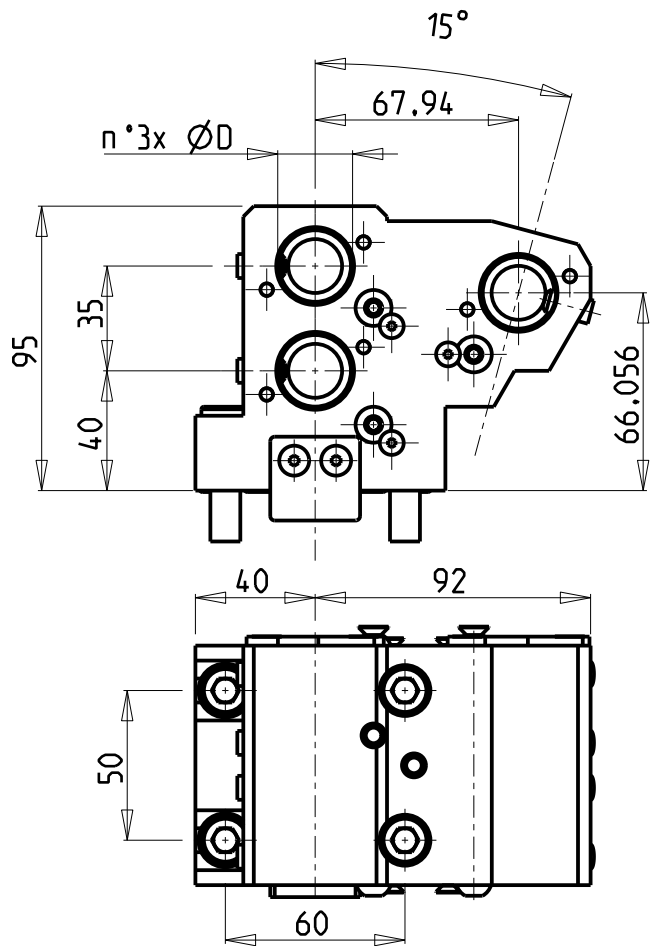

KIT ADDUZIONE INTERNA (OPZIONALE)
 KIT FOR INTERNAL COOLANT (OPTIONAL)
 KIT FUER INTERNE KUEHLMITTELZUFUHR (OPTIONAL)
 Ø25 cod. KIT1000006

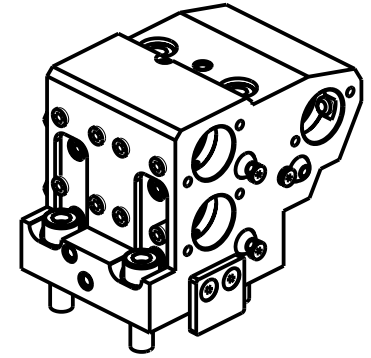
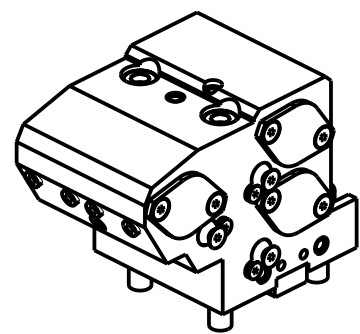
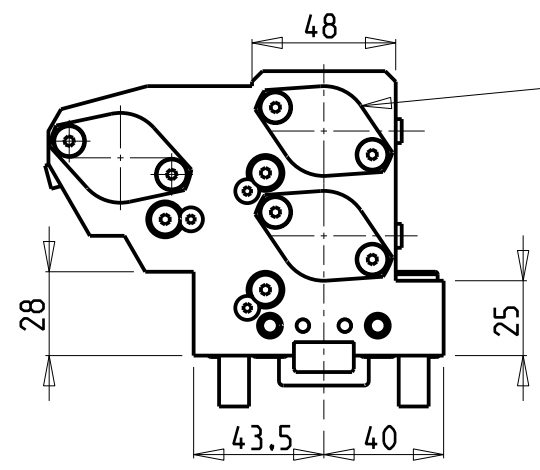
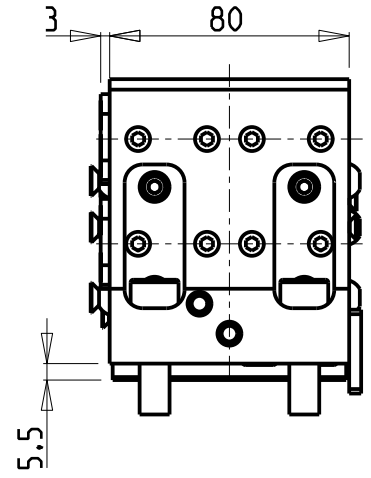

PER BOCCOLE DI RIDUZIONE VEDI PAG. TBL150-1-00
 FOR REDUCING BUSHINGS SEE PAGE TBL150-1-00
 FÜR REDUZIERBUCHSE SIEHE SEITE TBL150-1-00

Cod. MT	Reversibile lato mandrino/contromandrino Reversible sub/main spindle side Umkehrbare Spindel-seite/ Gegenspindel-seite	Lubrificazione int. opzionale Coolant through optional Innenkuehlung Optional	Lubrificazione est. Ext. coolant Aussenkuehlung	Misure Dimensions Masse	D
NKM1492500	X	X	X	mm	25
NKM1492540	X	X	X	inch	1"

NAKAMURA-TOME
 MOD: AS200 24ST.

PORTAUTENSILE ASSIALE PER BARENO 3 POSIZIONI Ø25mm / Ø1"
 Axial 3 position boring bar holder Ø25mm / Ø1"
 Axial Bohrhalter 3 Positionen Ø25mm / Ø1"

Subject to change without notice.

M.T. srl
 Via Casino Albini 480
 Tel. 0541/956034-957884
 Fax 0541/956341
 47842 S. GIOVANNI IN M. (RN)
 e-mail: mtma@mtmarchetti.com
 http://www.mtmarchetti.com

PRODUZIONE MODULI ROTANTI



PAGINA NKM884-2-20

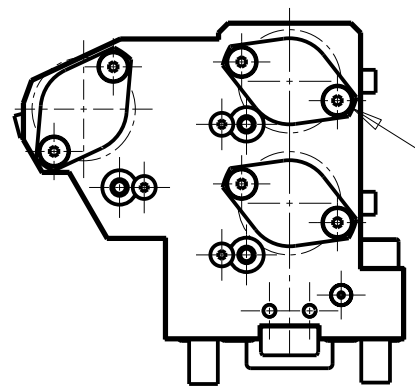
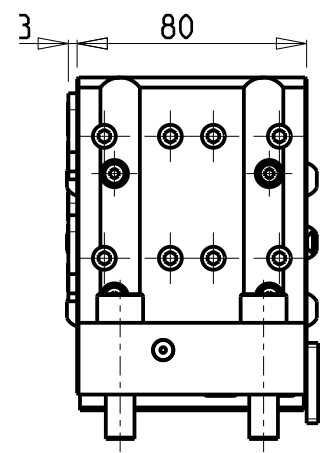
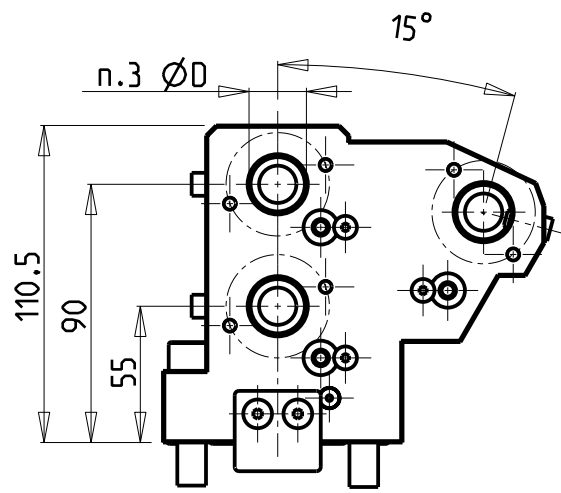

KIT ADDUZIONE INTERNA (OPZIONALE)
 KIT FOR INTERNAL COOLANT (OPTIONAL)
 KIT FUER INTERNE KUEHLMITTELZUFUHR (OPTIONAL)
 Ø20 cod. KIT1000015
 Ø25-Ø1" cod. KIT1000006

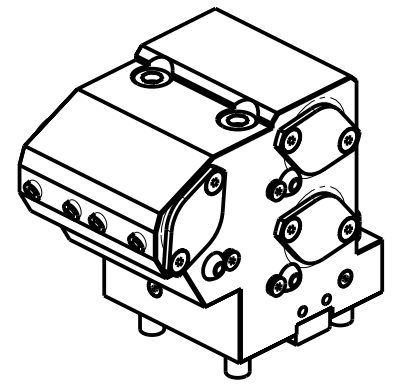
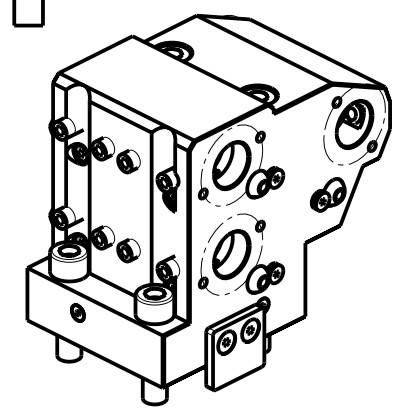
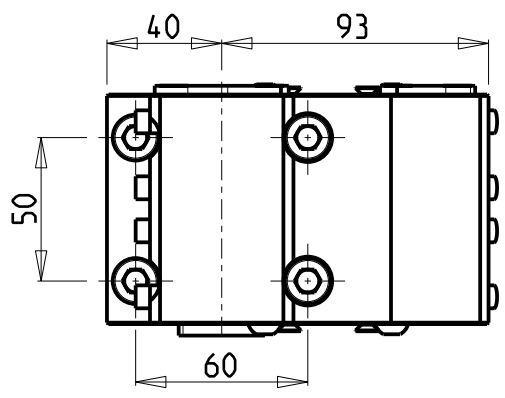

Cod. MT	N°Utensili N° Tools N° Werkzeuge	Reversibile lato mandrino/contromandrino Reversible sub/main spindle side Umkehrbare Spindel-seite/ Gegenspindel-seite	Lubrificazione int. opzionale Coolant through optional Innenkuehlung Optional	Lubrificazione est. Ext. coolant Aussenkuehlung	Misure Dimensions Masse	D
NKM0212000	3	X	X	X	mm	20
NKM0212500	3	X	X	X	mm	25

PER BOCCOLE DI RIDUZIONE VEDI PAG. TBL150-1-00
 FOR REDUCING BUSHINGS SEE PAGE TBL150-1-00
 FÜR REDUZIERBUCHSE SIEHE SEITE TBL150-1-00

NAKAMURA-TOME

MOD: W TW 150 - W TS150

PORTAUTENSILE ASSIALE PER BARENO 3 POSIZIONI Ø20mm / Ø25mm

Axial 3 position boring bar holder Ø20mm / Ø25mm

Axial Bohrhälter 3 Positionen Ø20mm / Ø25mm

Subject to change without notice.

M.T. srl

Via Casino Albini 480
 Tel. 0541/956034-957884
 Fax 0541/956341
 47842 S. GIOVANNI IN M. (RN)
 e-mail: mtma@mtmarchetti.com
 http://www.mtmarchetti.com

PRODUZIONE MODULI ROTANTI



PAGINA NKM886-2-00

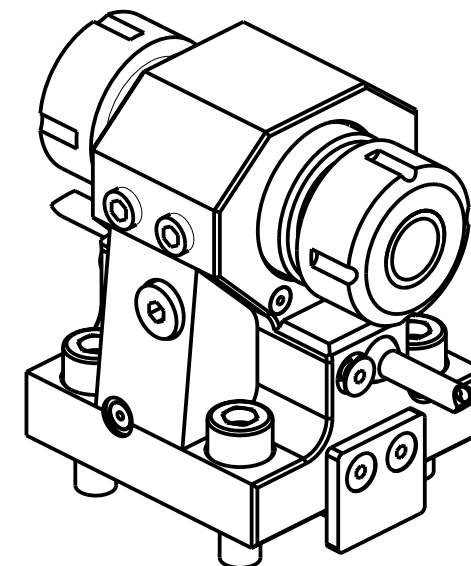
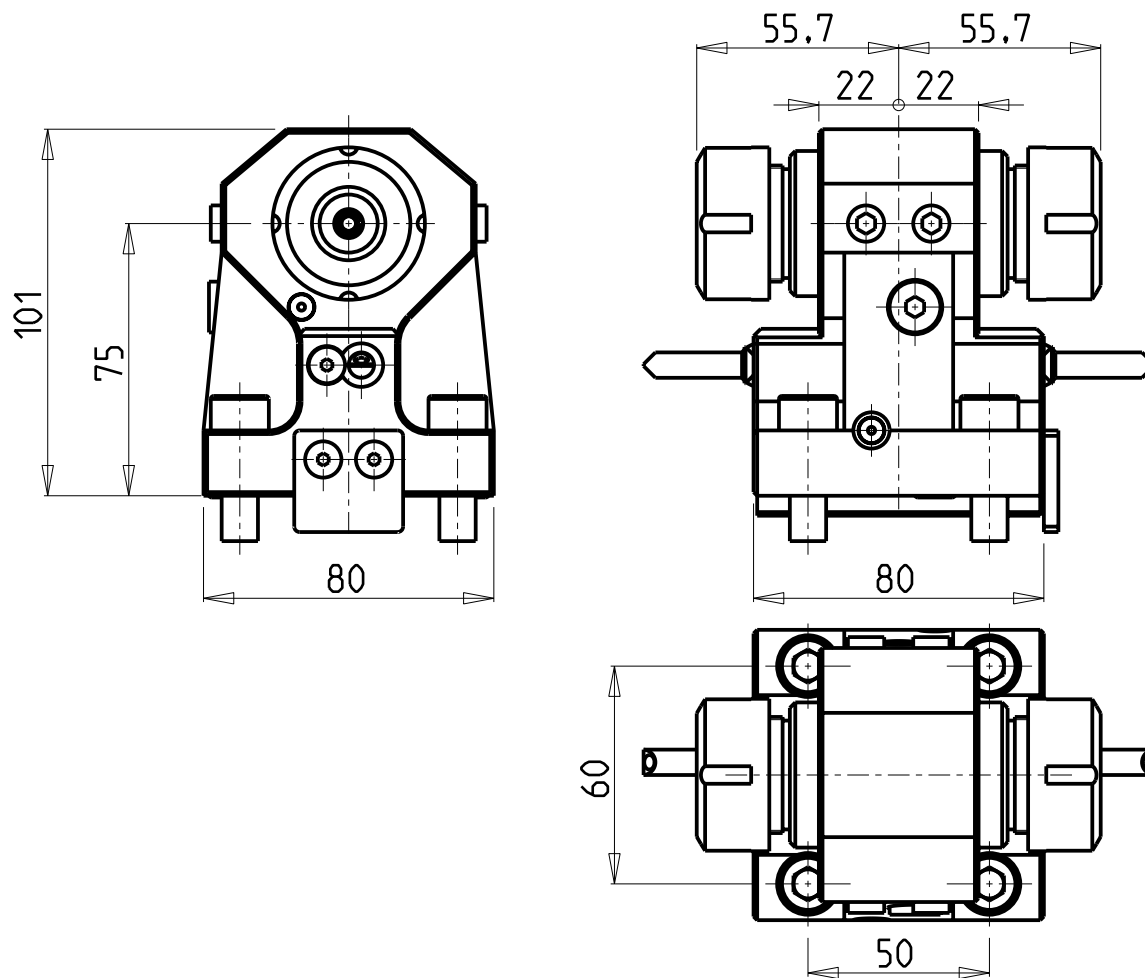

Cod. MT	N°Utensili N°Tools N°Werkzeuge	Mandrino Spindle Spindel	Reversibile lato mandrino/contromandrino Reversible sub/main spindle side Umkehrbare Spindel-seite/ Gegenspindel-seite	Lubr.interna Coolant through Innenkuehlung	Lubrificazione est. Ext. coolant Aussenkuehlung	CHIAVI NON INCLUDE Keys not included Schlüssel nicht einbegriffen
NKM1452525	2	ER25+ER25	X	X	X	CHSTER25

NAKAMURA-TOME

WT150/250 - WT15011/25011 - SUPER NTM3 - SUPER NTJ - SUPER NTJX - SC150/200/250 - NTY3 150/250
TW 10M/MY/MM/MMY/MMYY-TW 20M/MY/MM/MMY/MMYY 16 ST.

PORTAUTENSILE ASSIALE BISPORGENTE PORTAPINZA H=75mm

Axial double collet chuck holder H=75mm

Axial Doppel-Spannzangenhalter H=75mm

Subject to change without notice.

M.T. srl

Via Casino Albini 480
Tel. 0541/956034-957884
Fax 0541/956341
47842 S. GIOVANNI IN M. (RN)
e-mail: mtma@mtmarchetti.com
http://www.mtmarchetti.com

PRODUZIONE MODULI ROTANTI



PAGINA NKM940-2-00

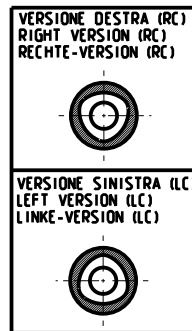
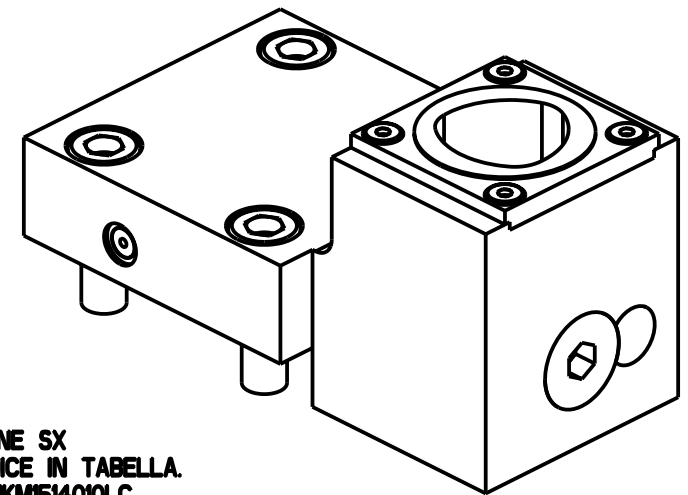
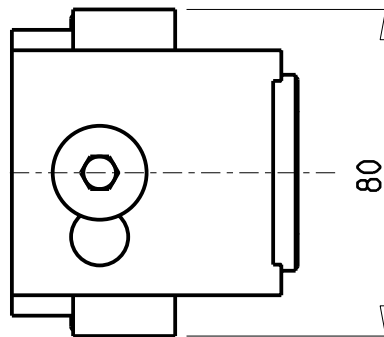
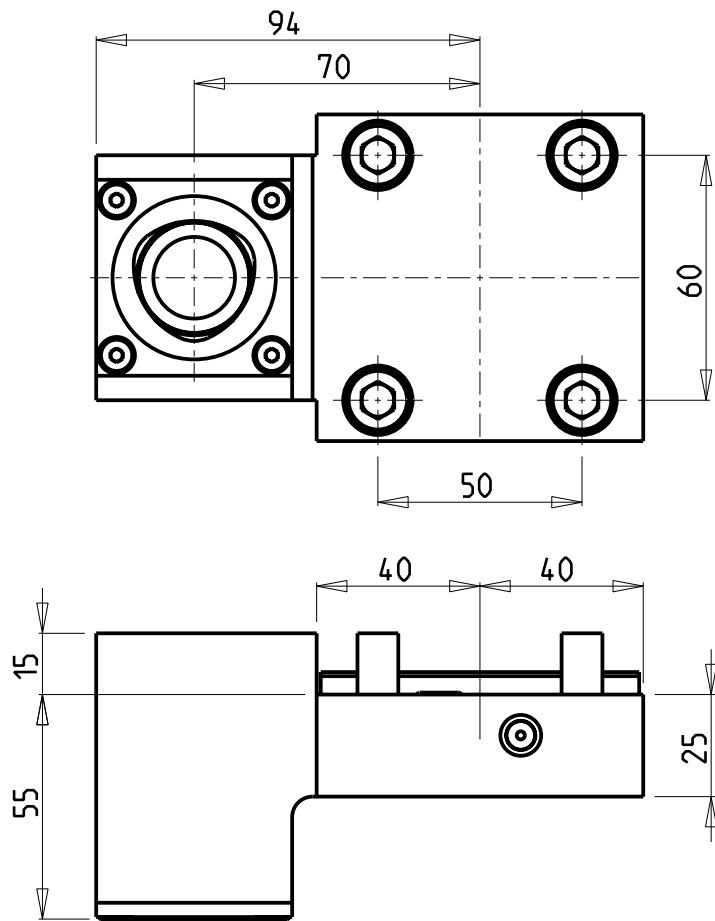

PER ORDINARE LA VERSIONE SX
AGGIUNGERE "LC" AL CODICE IN TABELLA.
ES: NKM1514010 DIVENTA NKM1514010LC

TO ORDER LEFT VERSION
ADD A "LC" IN THE CODE-CHARTS.
EXAMPLE: NKM1514010 BECOMES NKM1514010LC

UM DIE LINKE-VERSION ZU BESTELLEN, BEI DER
ARTIKELBEZEICHNUNG "LC" HINZUFUEGEN.
BEISPIEL: NKM1514010 WIRD DANN NKM1514010LC

Cod. MT	Lubrificazione int. Coolant through Innenkuehlung	Reversibile lato mandrino/contromandrino Reversible sub/main spindle side Umkehrbare Spindel-seite/ Gegenspindel-seite	TAGLIA Size Masse
NKM1514010	X	X	C4

NAKAMURA-TOME

WT150/250 - WT15011/25011 - WTW150 - WTS150 - SUPER NTM3 - SUPER NTJ - SUPER NTJX - SC150/200/250
NTY3 150/250 - TW10M/MY/MM/MMY/MMYY-TW20M/MY/MM/MMY/MMYY 16 ST. - WY 150/250 - AS200 15/24 ST.

PORTAUTENSILE RADIALE SINGOLO ARRETRATO MT CAPTO

Single rear-set radial static tool MT CAPTO

Radial Single-Werkzeughalter zurueckversetzt MT CAPTO

Subject to change without notice.

M.T. srl

Via Casino Albini 480
Tel. 0541/956034-957884
Fax 0541/956341
47842 S. GIOVANNI IN M. (RN)
e-mail: mtma@mtmarchetti.com
http://www.mtmarchetti.com

PRODUZIONE MODULI ROTANTI



PAGINA NKM430-B-40

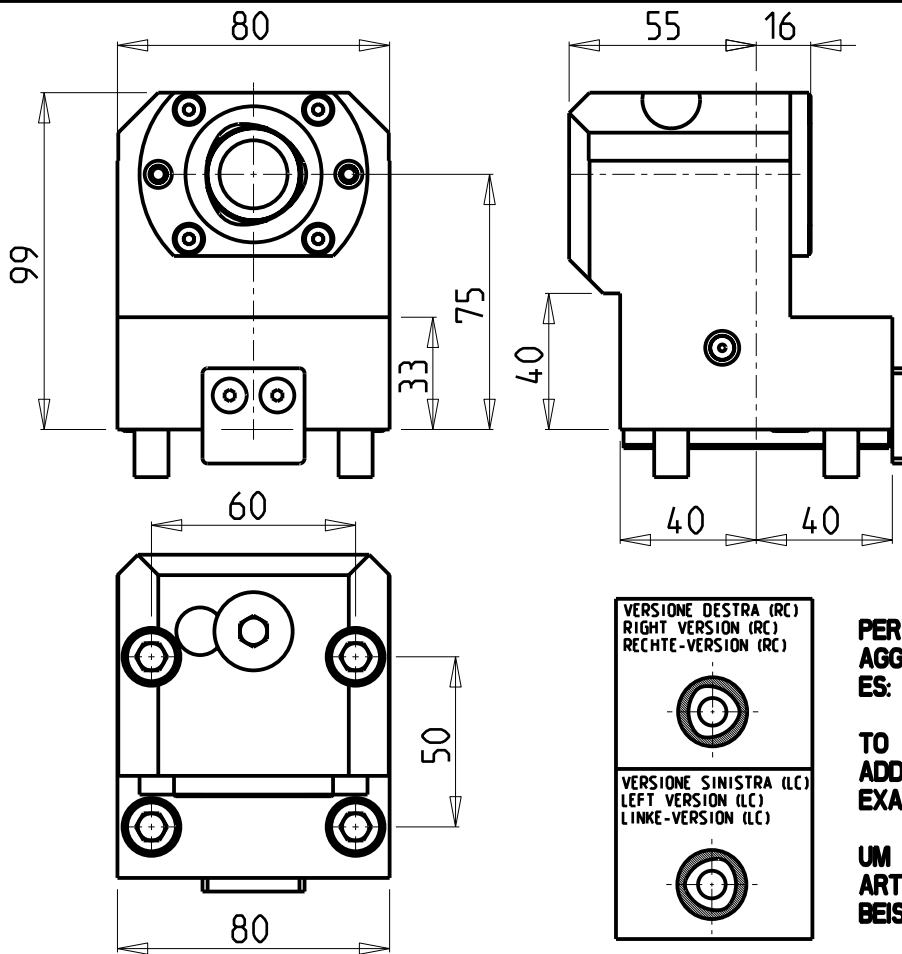

PER ORDINARE LA VERSIONE SX
 AGGIUNGERE "LC" AL CODICE IN TABELLA.
 ES: NKM1524010 DIVENTA NKM1524010LC

TO ORDER LEFT VERSION
 ADD A "LC" IN THE CODE-CHARTS.
 EXAMPLE: NKM1524010 BECOMES NKM1524010LC

UM DIE LINKE-VERSION ZU BESTELLEN, BEI DER
 ARTIKELBEZEICHNUNG "LC" HINZUFUEGEN.
 BEISPIEL: NKM1524010 WIRD DANN NKM1524010LC

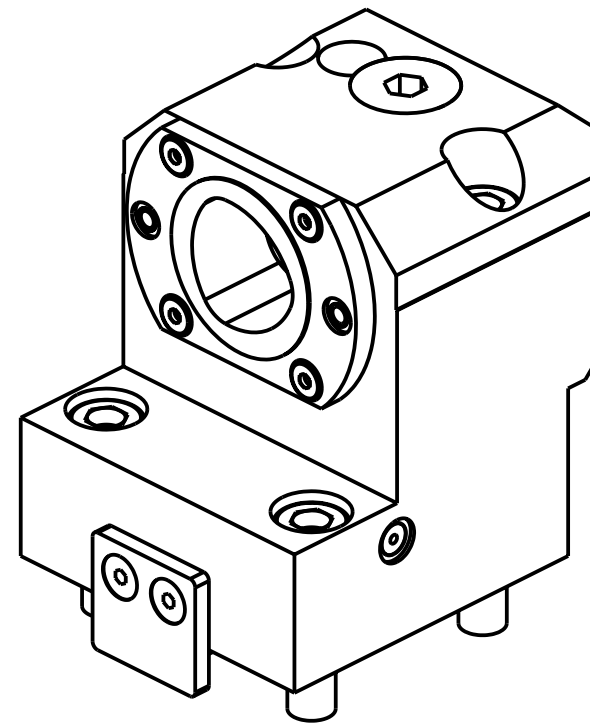

Cod. MT	Lubrificazione int. Coolant through Innenkuehlung	Reversibile lato mandrino/contromandrino Reversible sub/main spindle side Umkehrbare Spindelseite/ Gegenspindelseite	TAGLIA Size Masse
NKM1524010	X	X	C4

NAKAMURA-TOME

WT150/250 - WT15011/25011 - WTW150 - WTS150 - SUPER NTM3 - SUPER NTJ - SUPER NTJX - SC150/200/250
 NTY3 150/250 - TW10M/MY/MM/MMY/MMYY-TW20M/MY/MM/MMY/MMYY 16 ST. - WY 150/250 - AS200 15 ST.

PORTAUTENSILE ASSIALE SINGOLO ARRETRATO MT CAPTO

Axial rear-set boring single static tool MT CAPTO

Axial Single-Werkzeughalter zurueckversetzt MT CAPTO

Subject to change without notice.

M.T. srl

Via Casino Albini 480
 Tel. 0541/956034-957884
 Fax 0541/956341
 47842 S. GIOVANNI IN M. (RN)
 e-mail: mtma@tmarchetti.com
 http://www.mtmarchetti.com

PRODUZIONE MODULI ROTANTI



PAGINA NKM555-B-40

