

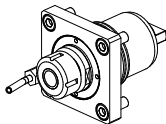
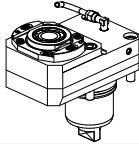
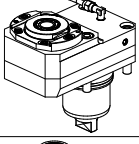
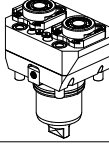
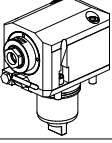
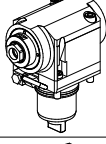
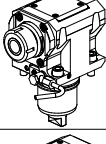

		PAGINA Page Seite
MODULO MOTORIZZATO RADIALE Radial driven tool Radial angetriebenes Werkzeug		NKM010.4.00
MODULO MOTORIZZATO RADIALE RIDOTTO I=2:1 DISASSATO IN Z 68mm Radial geared-down I=2:1 driven tool re-directed in Z by 68mm Radial angetriebenes Werkzeug untersetzt I=2:1 achsversetzt in Z um 68mm		NKM030.4.20
MODULO MOTORIZZATO RADIALE MOLTIPLICATO I=1:2 DISASSATO IN Z 68mm Radial geared-up I=1:2 driven tool re-directed in Z by 68mm Radial angetriebenes Werkzeug uebersetzt I=1:2 achsversetzt in Z um 68mm		NKM033.4.30
MODULO MOTORIZZATO RADIALE 2 USCITE IN Y MOLTIPLICATO I=1:2 Radial geared-up I=1:2 single side twin head driven tool in Y Radial angetriebenes Werkzeug 2 Ausgaenge in Y uebersetzt I=1:2		NKM080.4.10
MODULO MOTORIZZATO ASSIALE H=55mm Axial driven tool H=55mm Axial angetriebenes Werkzeug H=55mm		NKM150.4.10
MODULO MOTORIZZATO ASSIALE H=65mm Axial driven tool H=65mm Axial angetriebenes Werkzeug H=65mm		NKM150.4.20
MODULO MOTORIZZATO ASSIALE H=65mm Axial driven tool H=65mm Axial angetriebenes Werkzeug H=65mm		NKM150.4.21
MODULO MOTORIZZATO ASSIALE MTSK H=65mm Axial MTSK driven tool H=65mm Axial MTSK angetriebenes Werkzeug H=65mm		NKM150.4.21.K
MODULO MOTORIZZATO ASSIALE MOLTIPLICATO I=1:2 Axial geared-up I=1:2 driven tool Axial angetriebenes Werkzeug uebersetzt I=1:2		NKM200.4.10
MODULO MOTORIZZATO ASSIALE BISPORGENTE H=65mm Axial opposite face twin driven tool H=65mm Axial angetriebenes Werkzeug halb vorspringend H=65mm		NKM240.4.10
MODULO MOTORIZZATO ORIENTABILE ±90° ±90° adjustable angle driven tool Angetriebenes Werkzeug schwenkbar ±90°		NKM335.4.00
MODULO MOTORIZZATO ORIENTABILE ±90° CON NONIO DIGITALE ±90° adjustable angle driven tool with digital display Angetriebenes Werkzeug schwenkbar ±90° mit digital display		NKM335.4.01

		PAGINA Page Seite
<p>MODULO MOTORIZZATO ORIENTABILE $\pm 90^\circ$ MOLTIPLICATO 1:2 $\pm 90^\circ$ adjustable angle driven tool geared-up 1:2 Angetriebenes Werkzeug schwenkbar $\pm 90^\circ$ uebersetzt 1=1:2</p>		NKM336.4.00
<p>MOD. MOTOR. ORIENTABILE $\pm 90^\circ$ MOLTIPL. 1:2 CON NONIO DIGITALE $\pm 90^\circ$ adjustable angle driven tool geared-up 1:2 with digital display Angetriebenes Werkzeug schwenkbar $\pm 90^\circ$ uebersetzt 1=1:2 mit digital display</p>		NKM336.4.01
<p>MODULO MOTORIZZATO PORTACREATORE Driven gear hobber Angetriebenes Zahnradwaelzfraes-Werkzeug</p>		NKM340.4.00
<p>MODULO MOTORIZZATO ASSIALE MTSK PER POWER SKIVING H=90mm Axial MTSK driven tool for Power Skiving H=90mm Axial MTSK angetriebenes Werkzeug fuer Power Skiving H=90mm</p>		NKM350.4.00.K
<p>MODULO MOTORIZZATO STOZZATORE CORSA 50mm Slotting driven tool 50mm stroke Keilnutenstossmaschine 50mm Hub</p>		NKM360.4.00
<p>MODULO MOTORIZZATO STOZZATORE CORSA 25mm Slotting driven tool 25mm stroke Keilnutenstossmaschine 25mm Hub</p>		NKM360.4.01
<p>MODULO MOTORIZZATO PER LUNETTA RETRATTILE (TAGLIA 1) Driven toolholder for sliding steady rest (Size 1) Luenettenwerkzeug zurueck versetzte Version (Groesse 1)</p>		NKM363.4.00
<p>PORTAUTENSILE RADIALE SINGOLO QD=20mm / QD=25mm Radial single static tool QD=20mm / QD=25mm Radial Single-Werkzeughalter QD=20mm / QD=25mm</p>		NKM423.4.00
<p>PORTAUTENSILE RADIALE SOVRAPPOSTO QD=20mm / QD=3/4" Radial single side twin static tool QD=20mm / QD=3/4" Radial Werkzeughalter ueberlagert QD=20mm / QD=3/4"</p>		NKM440.4.00
<p>PORTAUTENSILE RADIALE DOPPIO QD=20mm / QD=25mm Radial double static tool QD=20mm / QD=25mm Radial Doppel-Werkzeughalter QD=20mm / QD=25mm</p>		NKM453.4.00
<p>PORTAUTENSILE RADIALE MULTIPLO QD=20mm / QD=3/4" Radial multiple static tool QD=20mm / QD=3/4" Radial Mehrfach-Halter QD=20mm / QD=3/4"</p>		NKM470.4.00
<p>PORTAUTENSILE RADIALE PER LAMA Radial blade holder Radial Abstechhalter</p>		NKM520.4.01

		PAGINA Page Seite
<p>PORTAUTENSILE RADIALE PER LAMA CON LUBRIFICAZIONE INTERNA Radial blade holder with internal coolant Radial Abstechhalter mit Innenkuehlung</p>		NKM520.4.05
<p>PORTAUTENSILE ASSIALE SINGOLO QD=20mm / QD=25mm Axial single static tool QD=20mm / QD=25mm Axial Single-Werkzeughalter QD=20mm / QD=25mm</p>		NKM552.4.00
<p>PORTAUTENSILE ASSIALE PER BARENO Ø32mm / Ø40mm H=75mm Axial single boring bar holder Ø32mm / Ø40mm H=75mm Axial Bohrhalter Ø32mm / Ø40mm H=75mm</p>		NKM650.4.10
<p>PORTAUTENSILE ASSIALE PER BARENO Ø25mm / Ø1" H=75mm Axial single boring bar holder Ø25mm / Ø1" H=75mm Axial Bohrhalter Ø25mm / Ø1" H=75mm</p>		NKM670.4.10
<p>PORTAUTENSILE ASSIALE PER BARENO 2 POSIZIONI Ø25mm / Ø1" Axial double boring bar holder Ø25mm / Ø1" Axial Bohrhalter 2 Positionen Ø25mm / Ø1"</p>		NKM864.4.00
<p>PORTAUTENSILE ASSIALE PER BARENO 3 POSIZIONI Ø25mm / Ø1" Axial 3 position boring bar holder Ø25mm / Ø1" Axial Bohrhalter 3 Positionen Ø25mm / Ø1"</p>		NKM884.4.00
<p>PORTAUTENSILE ASSIALE PER BARENO 3+3 POSIZIONI Ø20mm Axial 3+3 position boring bar holder Ø20mm Axial Bohrhalter 3+3 Positionen Ø20mm</p>		NKM914.4.00

<p>PORTAUTENSILE ASSIALE SINGOLO MT CAPTO Axial single static tool MT CAPTO Axial Single-Werkzeughalter MT CAPTO</p>		NKM550.D.40
<p>PORTAUTENSILE ASSIALE SINGOLO ARRETRATO MT CAPTO Axial rear-set boring single static tool MT CAPTO Axial Single-Werkzeughalter zurueckversetzt MT CAPTO</p>		NKM555.D.40

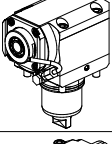
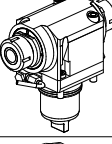
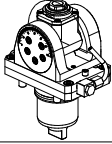
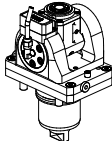
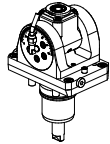
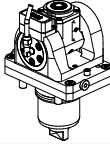
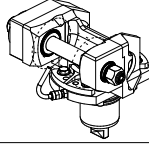
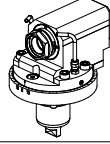
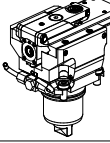
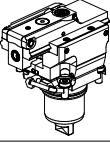
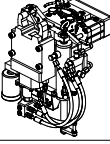
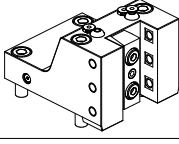
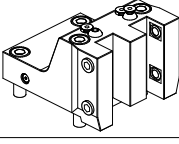
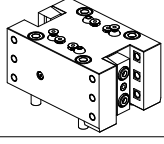
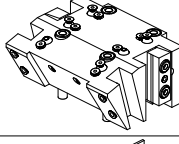
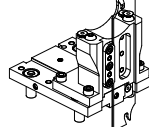
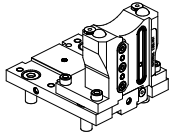
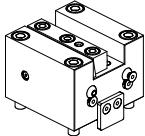
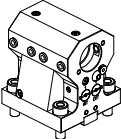
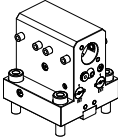
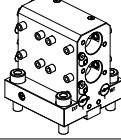
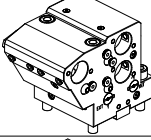
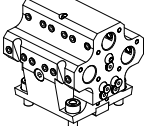
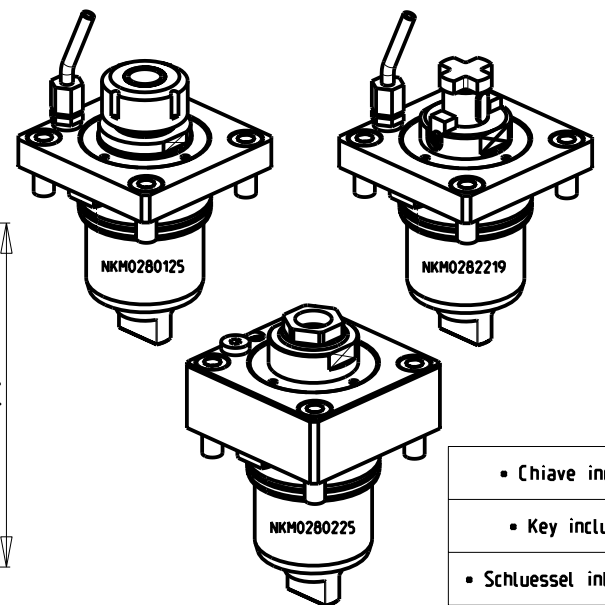
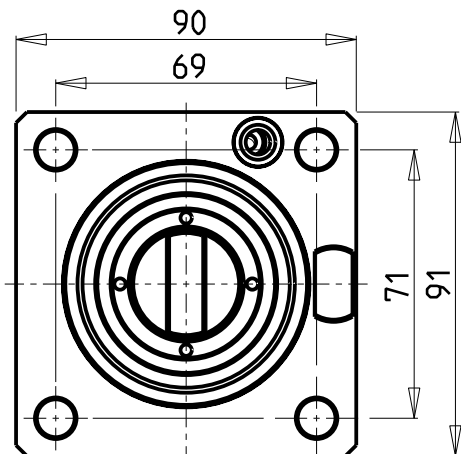
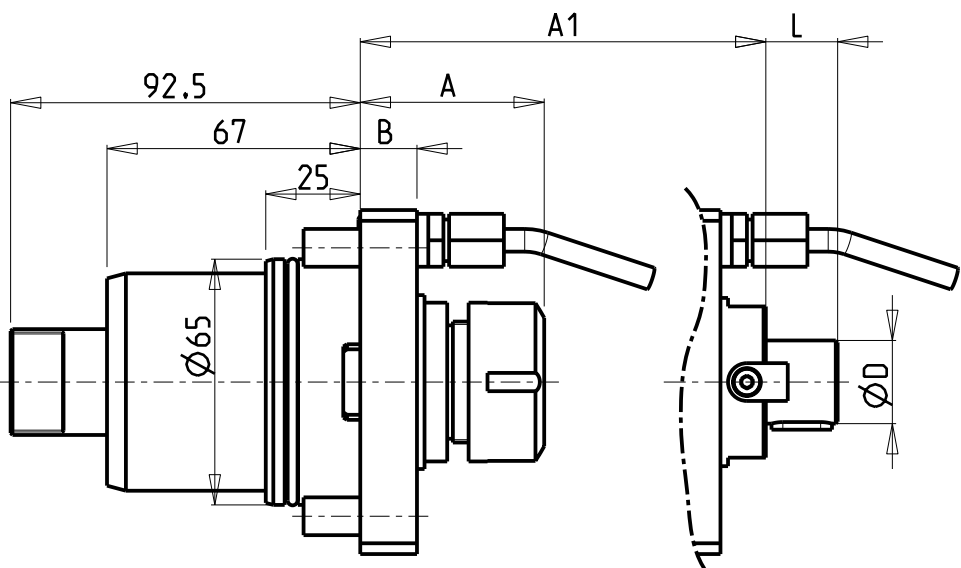

- Chiave inclusa
- Key included
- Schlüssel inbegriffen

Cod. MT	Cod. NAKAMURA	Mandrino Spindle Spindel	I	RPM	Coppia Max Max Torque Max Drehmoment	Lubrificazione int. Coolant through Innenkuhleung	Lubrificazione est. Ext. coolant Aussenkuhleung	A	A1	B	D	L	CHIAVI NON INCLUSE Keys not included Schlüssel nicht einbegriffen	
NKM0280125	-	ER25	1:1	6000	70Nm	-	X	48.66	-	15	-	-	CHUB42	CHSTER25
NKM0280132	G31330	ER32	1:1	6000	70Nm	-	X	56.16	-	15	-	-	OKU0650004 *	CHSTER32
NKM0280332	-	ER32	1:1	6000	70Nm	P=30bar	X	71.66	-	35	-	-	CHUB40	CHSTER32
NKM0280140	-	ER40	1:1	6000	70Nm	-	X	65.16	-	15	-	-	OKU0650004 *	CHSTER40
NKM0280225	-	ER A 25	1:1	6000	70Nm	P=30bar	X	59.03	-	35	-	-	CHUB40	CHUB27
NKM0280232	-	ER A 32	1:1	6000	70Nm	P=30bar	X	67.53	-	35	-	-	CHUB46	CHUB32
NKM0281617	-	Ø16x17	1:1	6000	70Nm	-	X	-	25	15	16	17	CHUB42	CH_VTCROCE_M08 *
NKM0282219	G31380	Ø22x19	1:1	6000	70Nm	-	X	-	27	15	22	19	CHUB40	CH_VTCROCE_M10 *
NKM0282721	-	Ø27x21	1:1	6000	70Nm	-	X	-	28	15	27	21	CHUB40	CH_VTCROCE_M12 *
NKM0281919	-	Ø3/4"x3/4"	1:1	6000	70Nm	-	X	-	25	15	3/4"	3/4"	CHUB42	CH_VTCROCE_M08 *
NKM0282519	-	Ø1"x19	1:1	6000	70Nm	-	X	-	29	15	1"	19	CHUB40	CH_VTCROCE_M12 *

NAKAMURA - TOME

MOD: Super Mill W T150/W T15011/W Y250/SC 200L - SUPER NTY3 JUMBO

MODULO MOTORIZZATO RADIALE
Radial driven tool
Radial angetriebenes Werkzeug

Subject to change without notice.

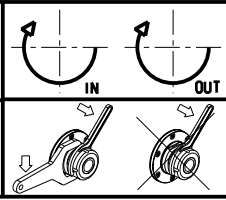

M.T. srl
Via Casino Albini 480
Tel. 0541/956034-957884
Fax 0541/956341
47842 S. GIOVANNI IN M. (RN)
e-mail: mtma@mtmarchetti.com
http://www.mtmarchetti.com

PRODUZIONE MODULI ROTANTI



PAGINA NKM010-4-00

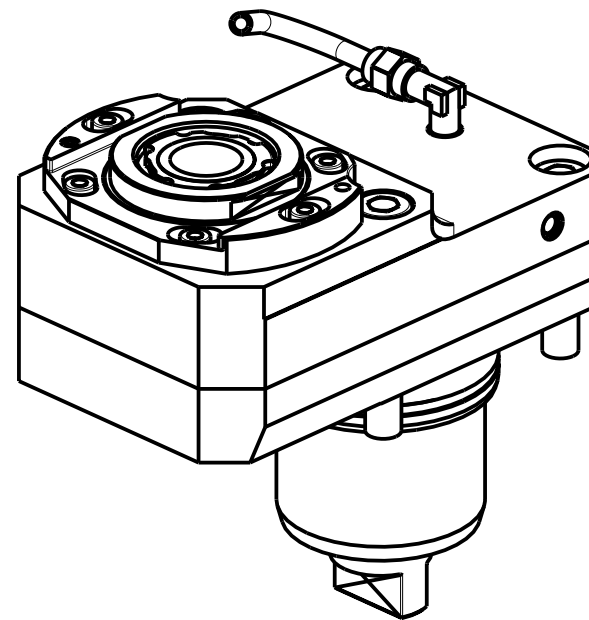
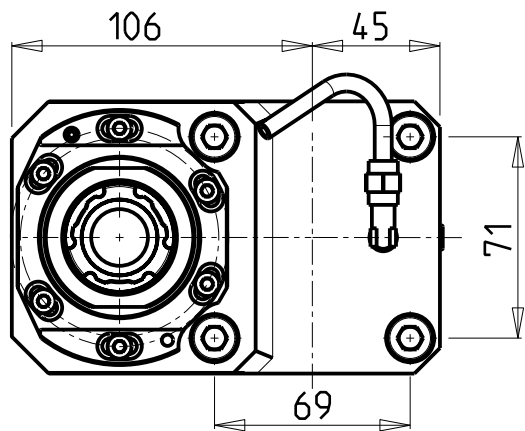
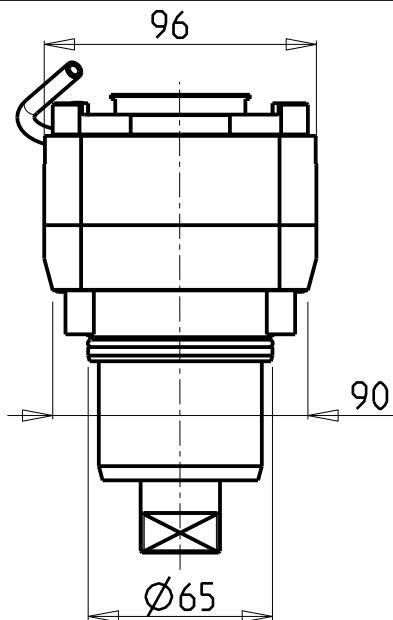
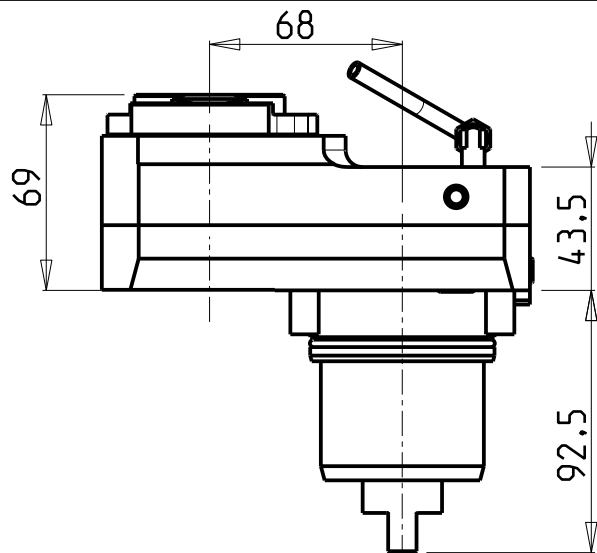

Cod. MT	Mandrino Spindle Spindel	I	RPM	Coppia Max Max Torque Max Drehmoment	Reversibile lato mandrino/contromandrino Reversible sub/main spindle side Umkehrbare Spindel-seite/ Gegenspindel-seite	Lubr.esterna Ext. coolant Aussenkuehlung	CHIAVI NON INCLUSE Keys not included Schluessel nicht einbegriffen		
NKM0752132	ERA32	2:1	3000	70Nm	X	X	CHUB30	CHTAER32ZC	OKU0650004

- Chiave inclusa
- Key included
- Schluessel inbegriffen

NAKAMURA-TOME

MOD: Super Mill WT150/WT15011/WY250/SC200L - SUPER NTY3 JUMBO

MODULO MOTORIZZATO RADIALE RIDOTTO I=2:1 DISASSATO IN Z 68mm

Radial geared-down I=2:1 driven tool re-directed in Z by 68mm

Radial angetriebenes Werkzeug untersetzt I=2:1 achsversetzt in Z um 68mm

Subject to change without notice.

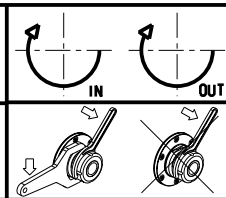

M.T. srl
Via Casino Albini 480
Tel. 0541/956034-957884
Fax 0541/956341
47842 S. GIOVANNI IN M. (RN)
e-mail: mtma@mtmarchetti.com
http://www.mtmarchetti.com

PRODUZIONE MODULI ROTANTI



PAGINA NKM030-4-20

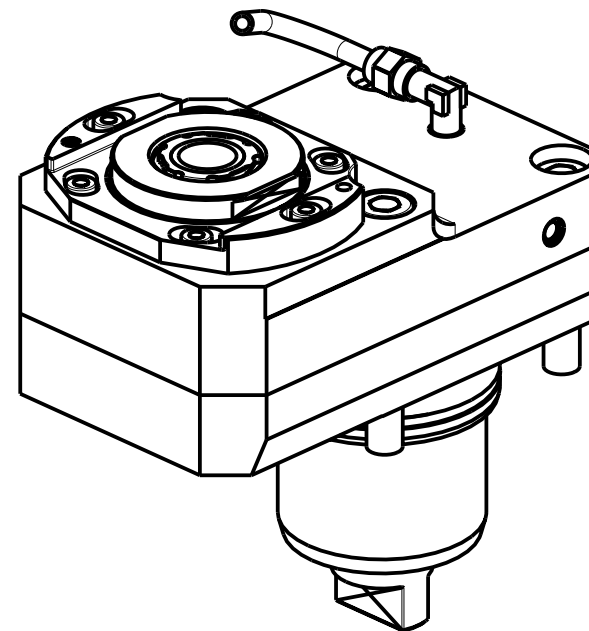
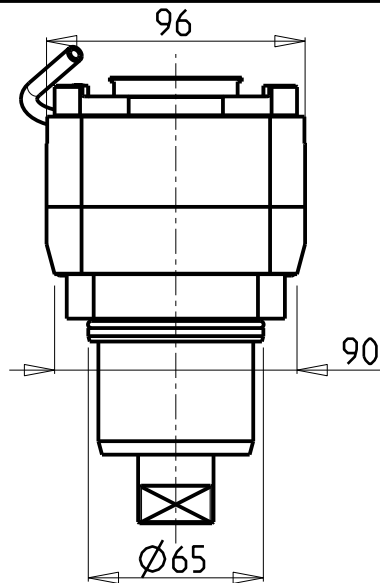
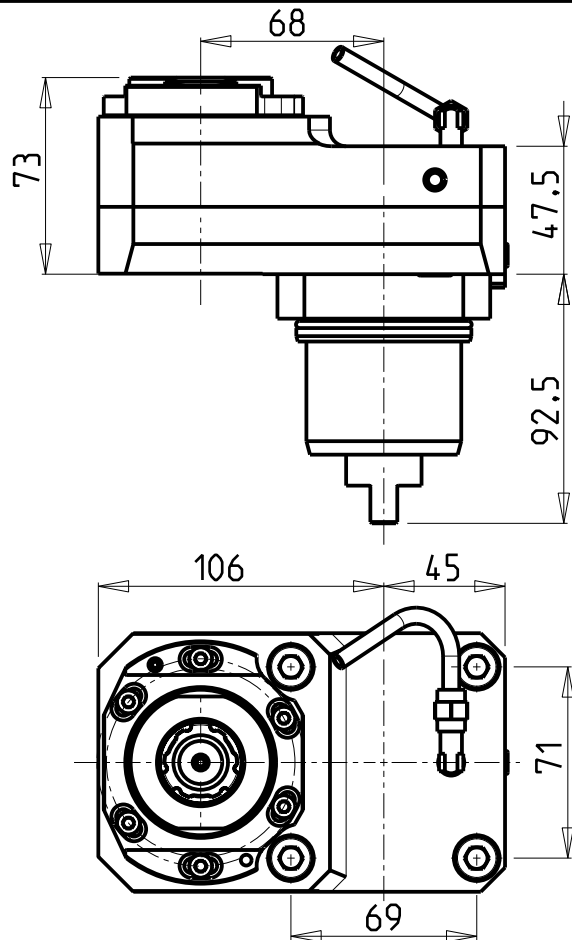

- Chiave inclusa
- Key included
- Schluessel inbegriffen

Cod. MT	Mandrino Spindle Spindel	i	RPM MAX	Coppia Max Max Torque Max Drehmoment	Reversibile lato mandrino/contromandrino Reversible sub/main spindle side Umkehrbare Spindelseite/ Gegenspindelseite	Lubr.interna Coolant through Innenkuehlung	Lubrificazione est. Ext. coolant Aussenkuehlung	CHIAVI NON INCLUSE Keys not included Schluessel nicht einbegriffen		
								CHUB27	CHTAER25ZC ▪	OKU0650004 ▪
NKM0852132	ER A 25	1:2	12000	30Nm	X	-	X	CHUB27	CHTAER25ZC ▪	OKU0650004 ▪
NKM0854225	ER A 25	1:2	12000	30Nm	X	P=70bar	X	CHUB27	CHTAER25ZC ▪	OKU0650004 ▪

NAKAMURA-TOME

MOD: Super Mill WT150/WT15011/WY250/SC200L - SUPER NTY3 JUMBO

MODULO MOTORIZZATO RADIALE MOLTIPLICATO I=1:2 DISASSATO IN Z 68mm
 Radial geared-up I=1:2 driven tool re-directed in Z by 68mm
 Radial angetriebenes Werkzeug uebersetzt I=1:2 achsversetzt in Z um 68mm

Subject to change without notice.

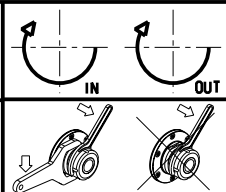

M.T. srl
 Via Casino Albini 480
 Tel. 0541/956034-957884
 Fax 0541/956341
 47842 S. GIOVANNI IN M. (RN)
 e-mail: mtma@mtmarchetti.com
 http://www.mtmarchetti.com

PRODUZIONE MODULI ROTANTI



PAGINA NKM033-4-30

ATTENZIONE - ATTENTION - ACHTUNG

- Per lo smontaggio degli utensili utilizzare sempre la chiave di contrasto come indicato nel manuale d'uso.
- For disassembly of the tools use always the contrast key as mentioned in the user instructions.
- Fuer das Abmontieren der Werkzeuge immer den Gegenschlüssel benutzen wie in der Bedienungsanleitung erwaeht.

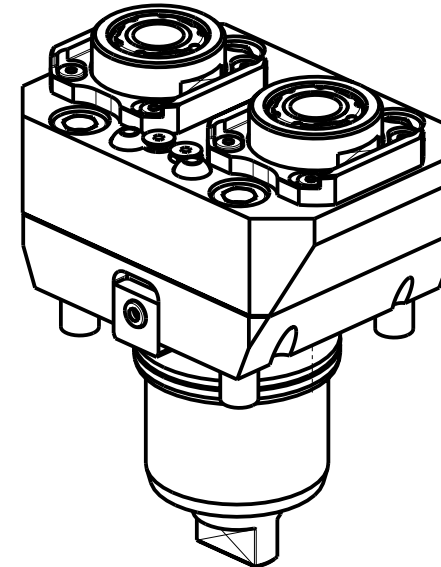
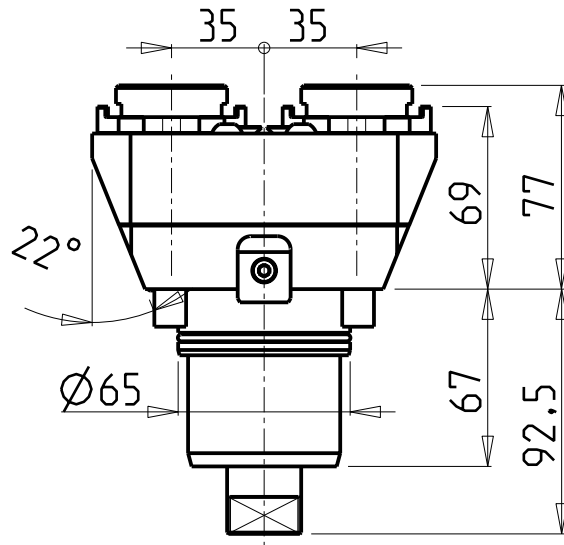
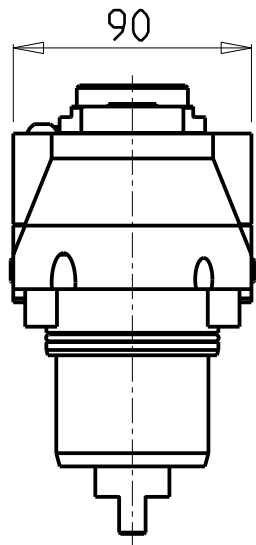
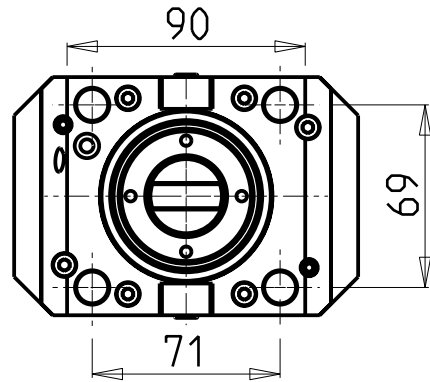

- Chiave inclusa
- Key included
- Schluessel inbegriffen

Cod. MT	Mandrino Spindle Spindel	I	RPM	Coppia Max Max Torque Max Drehmoment	Lubrificazione est. Ext. coolant Aussenkuehlung	CHIAVI NON INCLUSE Keys not included Schluessel nicht inbegriffen		
NKM1120325	ERA25	1:2	12000	30Nm	X	CHUB27	CHTAER25ZC	OKU0290009

NAKAMURA-TOME

MOD: Super Mill WT150/WT15011/WY250/SC200L - SUPER NTY3 JUMBO

MODULO MOTORIZZATO RADIALE 2 USCITE IN Y MOLTIPLICATO I=1:2

Radial geared-up I=1:2 single side twin head driven tool in Y

Radial angetriebenes Werkzeug 2 Ausgaenge in Y uebersetzt I=1:2

Subject to change without notice.

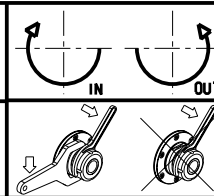

M.T. srl

Via Casino Albini 480
Tel. 0541/956034-957884
Fax 0541/956341
47842 S. GIOVANNI IN M. (RN)
e-mail: mtma@mtmarchetti.com
http://www.mtmarchetti.com

PRODUZIONE MODULI ROTANTI



PAGINA NKM080-4-10

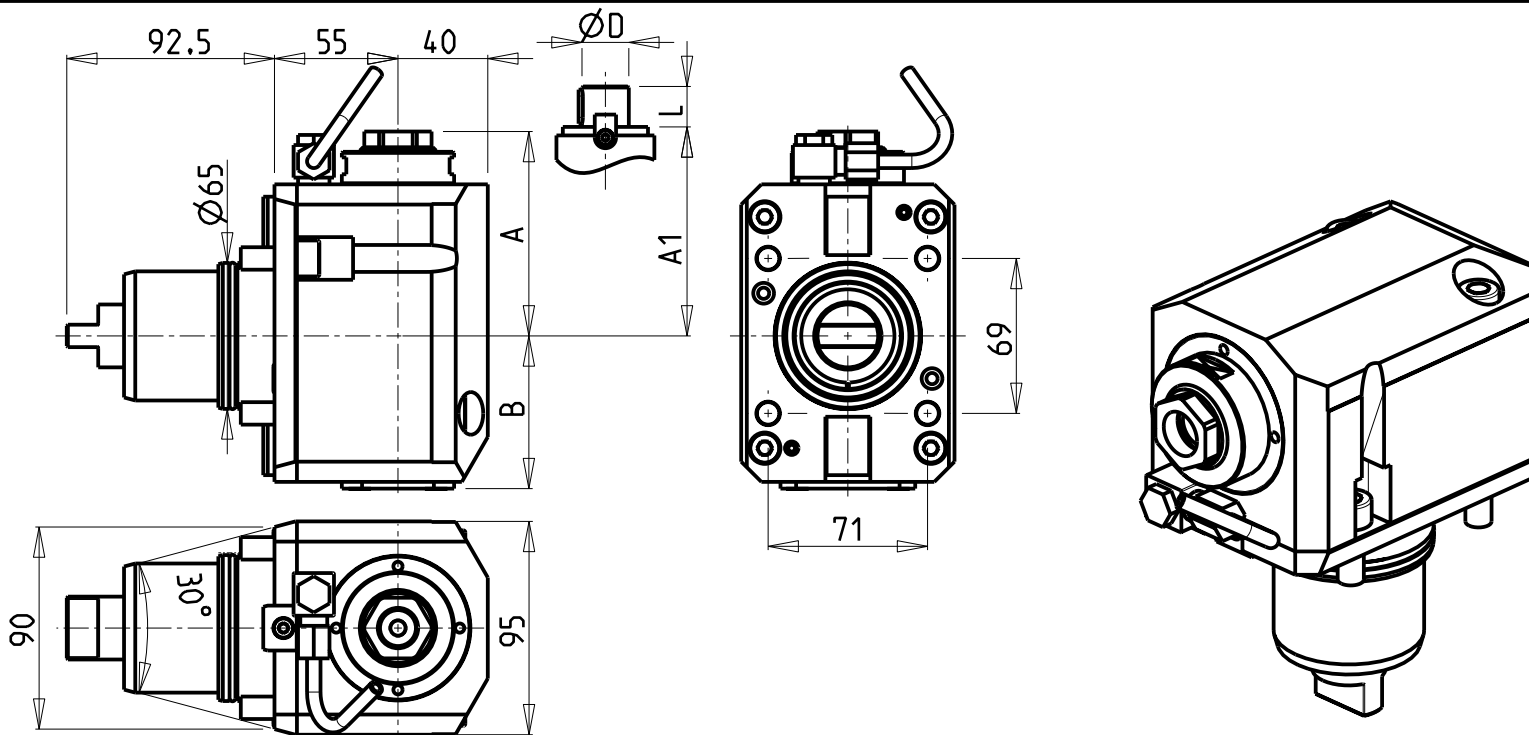

ATTENZIONE - ATTENTION - ACHTUNG

- Per lo smontaggio degli utensili utilizzare sempre la chiave di contrasto come indicato nel manuale d'uso.
- For disassembly of the tools use always the contrast key as mentioned in the user instructions.
- Fuer das Abmontieren der Werkzeuge immer den Gegenschlüssel benutzen wie in der Bedienungsanleitung erwaehtnt.

- Chiave inclusa
- Key included
- Schlüssel inbegriffen

Cod. MT	Cod. NAKAMURA	Mandrino Spindle Spindel	I	RPM	Coppia Max Max Torque Max Drehmoment	Reversibile lato mandrino/contromandrino Reversible sub/main spindle side Umkehrbare Spindelseite/Gegenspindelseite	Lubr.interna Coolant through Innenkuehlung	Lubr.esterna Ext. coolant Aussenkuehlung	A	A1	B	D	L	CHIAVI NON INCLUDE Keys not included Schluessel nicht einbegriffen	
NKM0290125	-	ER A 25	1:1	6000	70Nm	X	-	X	91.03	-	68	-	-	CHUB46	CHUB27
NKM0290132	G31333	ER A 32	1:1	6000	70Nm	X	-	X	94.53	-	68	-	-	CHUB46	CHUB32
NKM0290140	-	ER40	1:1	6000	70Nm	X	-	X	108.16	-	68	-	-	CHUB46	CHSTER40
NKM0290225	-	ER A 25	1:1	6000	70Nm	X	P=70bar	X	91.03	-	91.5	-	-	CHUB46	CHUB27
NKM0290232	G31339	ER A 32	1:1	6000	70Nm	X	P=70bar	X	94.53	-	91.5	-	-	CHUB46	CHUB32
NKM0290240	-	ER40	1:1	6000	70Nm	X	P=70bar	X	108.16	-	79	-	-	CHUB46	CHSTER40
NKM0292219	-	Ø22x19	1:1	6000	70Nm	X	-	X	-	80	68	22	19	CHUB46	CH_VTCROCE_M10 *

NAKAMURA-TOME

MOD: Super Mill W T150/W T15011/W Y250/SC 200L - SUPER NTY3 JUMBO

MODULO MOTORIZZATO ASSIALE H=55mm

Axial driven tool H=55mm

Axial angetriebenes Werkzeug H=55mm

Subject to change without notice.

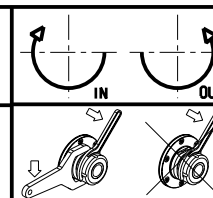

M.T. srl

Via Casino Albini 480
Tel. 0541/956034-957884
Fax 0541/956341
47842 S. GIOVANNI IN M. (RN)
e-mail: mtma@tmarchetti.com
http://www.tmmarchetti.com

PRODUZIONE MODULI ROTANTI



PAGINA NKM150-4-10

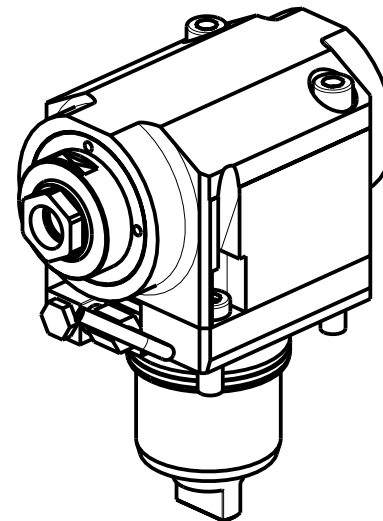
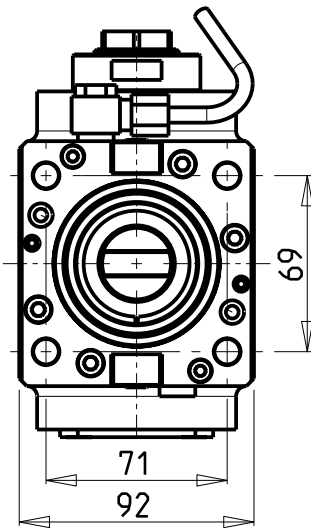
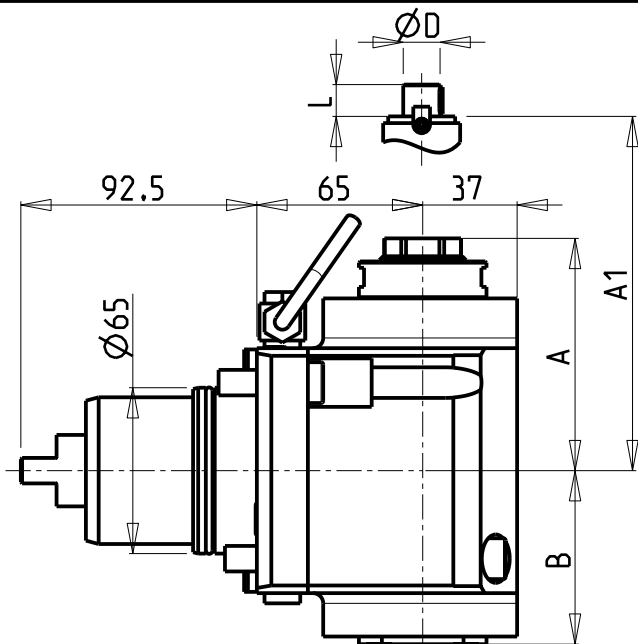

ATTENZIONE - ATTENTION - ACHTUNG

- Per lo smontaggio degli utensili utilizzare sempre la chiave di contrasto come indicato nel manuale d'uso.
- For disassembly of the tools use always the contrast key as mentioned in the user instructions.
- Fuer das Abmontieren der Werkzeuge immer den Gegenschlüssel benutzen wie in der Bedienungsanleitung erwäehnt.

- Chiave inclusa
- Key included
- Schlüssel inbegriffen

Cod. MT	Mandrino Spindel	I	RPM	Coppia Max Max Torque Max Drehmoment	Reversibile lato mandrino/contromandrino Reversible sub/main spindle side Umkehrbare Spindel-seite/ Gegenspindel-seite	Lubr.interna Coolant through Innenkuehlung	Lubr.esterna Ext. coolant Aussenkuehlung	A	A1	B	CHIAVI NON INCLUSE Keys not included Schluesssel nicht einbegriffen	
NKM0610125	ER A 25	1:1	6000	70Nm	X	-	X	91.03	-	68	CHUB46	CHUB27
NKM0610132	ER A 32	1:1	6000	70Nm	X	-	X	94.53	-	68	CHUB46	CHUB32
NKM0610140	ER40	1:1	6000	70Nm	X	-	X	108.16	-	68	CHUB46	CHSTER40
NKM0610225	ER A 25	1:1	6000	70Nm	X	P=70bar	X	91.03	-	91.5	CHUB46	CHUB27
NKM0610232	ER A 32	1:1	6000	70Nm	X	P=70bar	X	94.53	-	91.5	CHUB46	CHUB32
NKM0610240	ER40	1:1	6000	70Nm	X	P=70bar	X	108.16	-	79	CHUB46	CHSTER40
NKM0612219	Ø22x19	1:1	6000	70Nm	X	-	X	-	80	68	CHUB46	CH_VTCROCE_M10 *

NAKAMURA-TOME

MOD: Super Mill W T150/W T15011/W Y250/SC200L - SUPER NTY3 JUMBO

MODULO MOTORIZZATO ASSIALE H=65mm

Axial driven tool H=65mm

Axial angetriebenes Werkzeug H=65mm

Subject to change without notice.

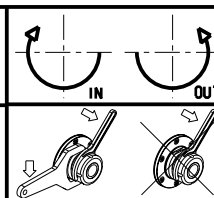

M.T. srl

Via Casino Albini 480
Tel. 0541/956034-957884
Fax 0541/956341
47842 S. GIOVANNI IN M. (RN)
e-mail: mtma@mtmarchetti.com
http://www.mtmarchetti.com

PRODUZIONE MODULI ROTANTI



PAGINA NKM150-4-20

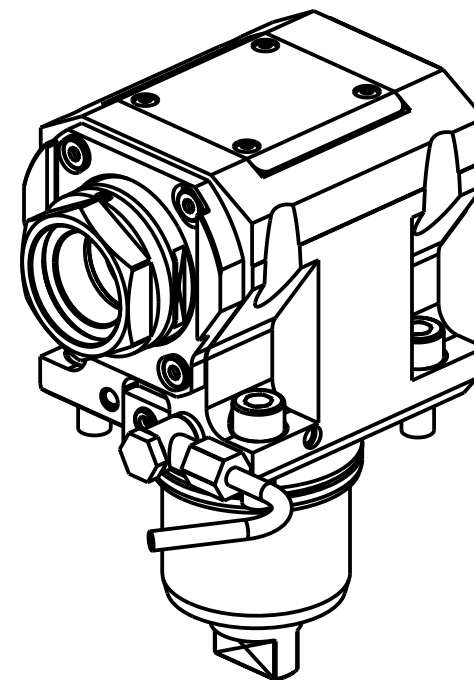
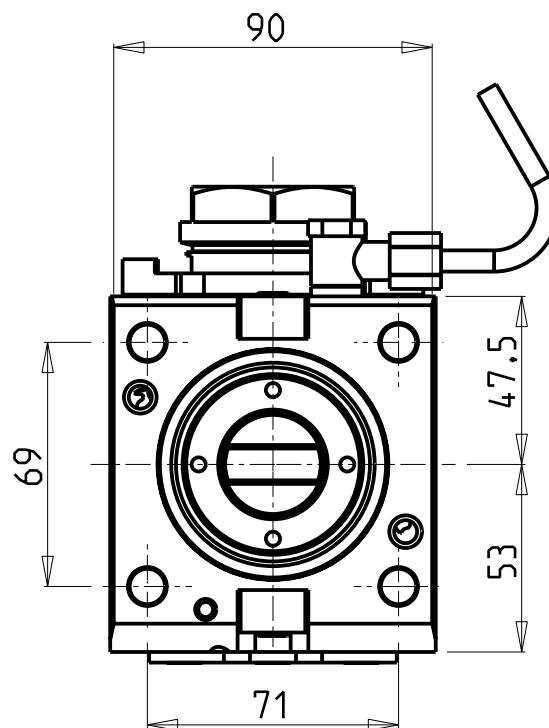
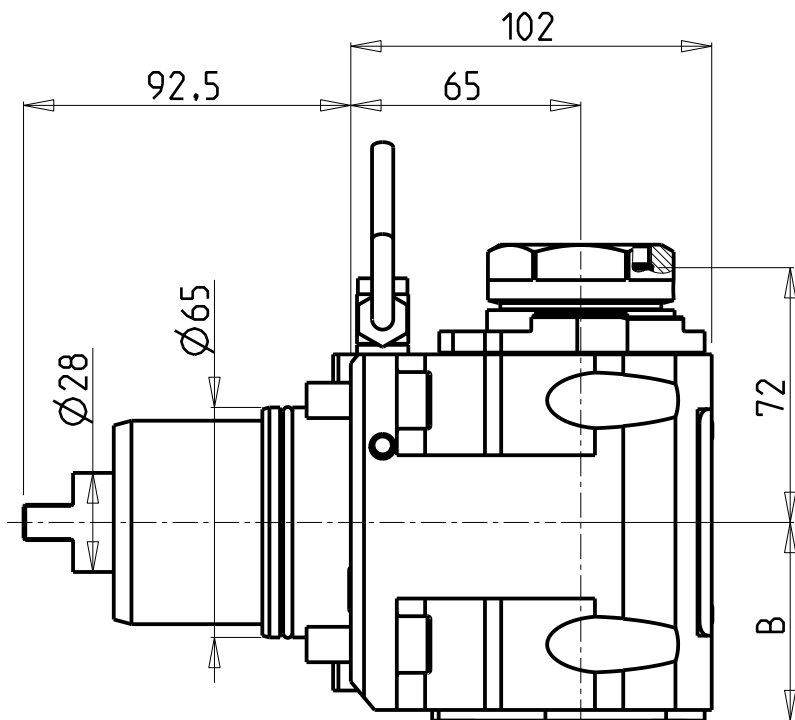

PER PORTAUTENSILI MODULARI MTSK-40 VEDI PAG. TBL300-1-40
 FOR MTSK-40 QUICK CHANGE TOOLHOLDERS CLAMPINGS SEE PAGE TBL300-1-40
 FUER MTSK-40 MODULARE WERKZEUGAUFNAHMEN SIEHE SEITE TBL300-1-40

Cod. MT	Mandrino Spindle Spindel	I	RPM	Coppia Max Max Torque Max Drehmoment	Reversibile lato mandrino/contromandrino Reversible sub/main spindle side Umkehrbare Spindel-seite/ Gegenspindel-seite	Lubrificazione int. Coolant through Innenkuehlung	Lubrificazione est. Ext. coolant Aussenkuehlung	B	CHIAVI NON INCLUDE Keys not included Schluessel nicht einbegriffen	
NKM1440140	MTSK-40	1:1	6000	70Nm	X	-	X	56	CHUB46	OKU0650004 *
NKM1440240	MTSK-40	1:1	6000	70Nm	X	P=70bar	X	67	CHUB46	OKU0650004 *

- Chiave inclusa
- Key included
- Schluessel inbegriffen

NAKAMURA-TOME

MOD: Super Mill WT150/W T15011/W Y250/SC200L - SUPER NTY3 JUMBO

MODULO MOTORIZZATO ASSIALE MTSK H=65mm

Axial MTSK driven tool H=65mm

Axial MTSK angetriebenes Werkzeug H=65mm

Subject to change without notice.

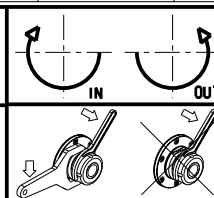

M.T. srl

Via Casino Albini 480
 Tel. 0541/956034-957884
 Fax 0541/956341
 47842 S. GIOVANNI IN M. (RN)
 e-mail: mtma@mtmarchetti.com
 http://www.mtmarchetti.com

PRODUZIONE MODULI ROTANTI



PAGINA NKM150-4-21-K

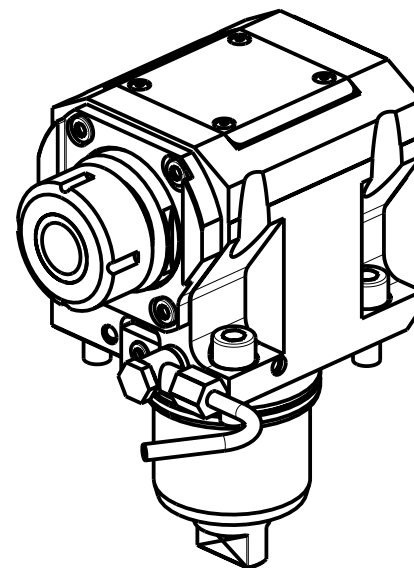
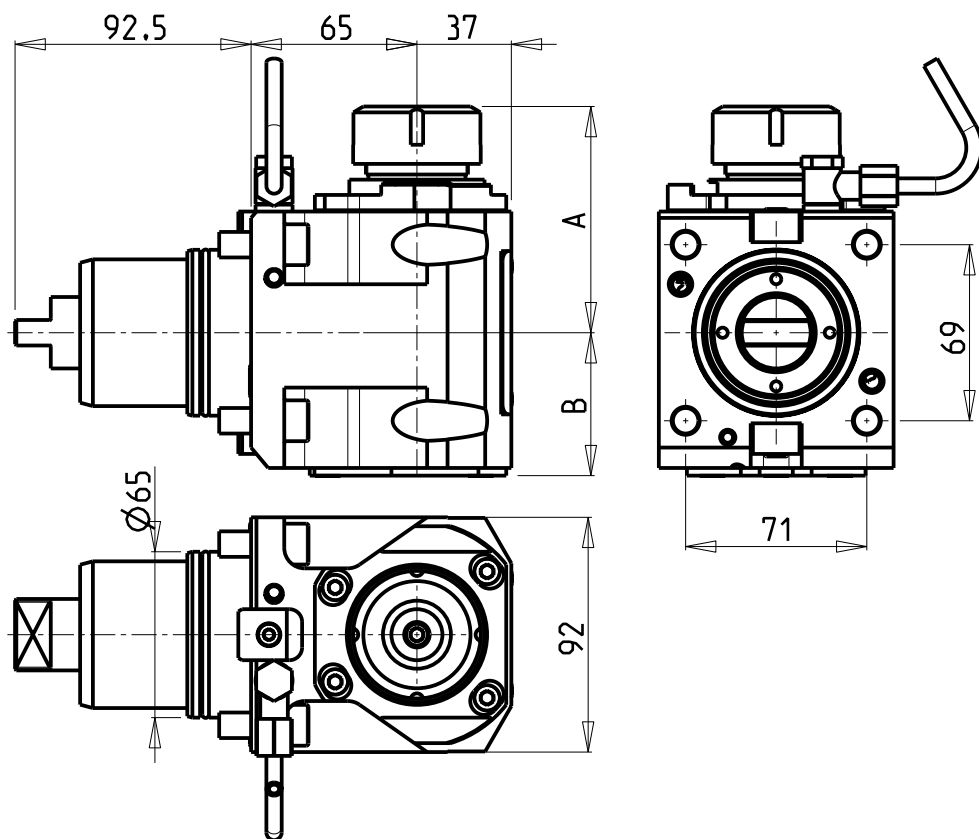

ATTENZIONE - ATTENTION - ACHTUNG

- Per lo smontaggio degli utensili utilizzare sempre la chiave di contrasto come indicato nel manuale d'uso.
- For disassembly of the tools use always the contrast key as mentioned in the user instructions.
- Fuer das Abmontieren der Werkzeuge immer den Gegenschlüssel benutzen wie in der Bedienungsanleitung erwaeht.

• Chiave inclusa

• Key included

• Schlüssel inbegriffen

Cod. MT	Mandrino Spindel Spindel	I	RPM	Coppia Max Max Torque Max Drehmoment	Reversibile lato mandrino/contromandrino Reversible sub/main spindle side Umkehrbare Spindelseite/ Gegenspindelseite	Lubr.interna Coolant through Innenkuehlung	Lubr.esterna Ext. coolant Aussenkuehlung	A	B	CHIAVI NON INCLUDE Keys not included Schluessel nicht einbegriffen	
NKM0740132	ER32	1:1	6000	70Nm	X	-	X	88.66	56	CHSTER32	OKU0650004 *
NKM0740232	ER32	1:1	6000	70Nm	X	P=70bar	X	88.66	67	CHSTER32	OKU0650004 *
NKM0740140	ER40	1:1	6000	70Nm	X	-	X	99.16	56	CHSTER40	OKU0650004 *
NKM0740240	ER40	1:1	6000	70Nm	X	P=70bar	X	99.16	67	CHSTER40	OKU0650004 *

NAKAMURA-TOME

MOD: Super Mill W T150/W T15011/W Y250/SC200L - SUPER NTY3 JUMBO

MODULO MOTORIZZATO ASSIALE H=65mm

Axial driven tool H=65mm

Axial angetriebenes Werkzeug H=65mm

Subject to change without notice.

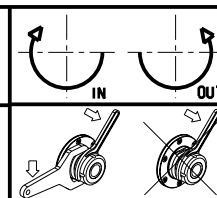

M.T. srl

Via Casino Albini 480
Tel. 0541/956034-957884
Fax 0541/956341
47842 S. GIOVANNI IN M. (RN)
e-mail: mtma@mtmarchetti.com
http://www.mtmarchetti.com

PRODUZIONE MODULI ROTANTI



PAGINA NKM150-4-21

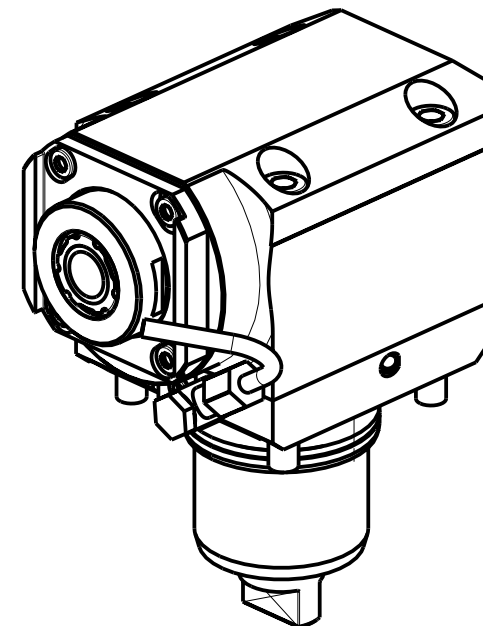
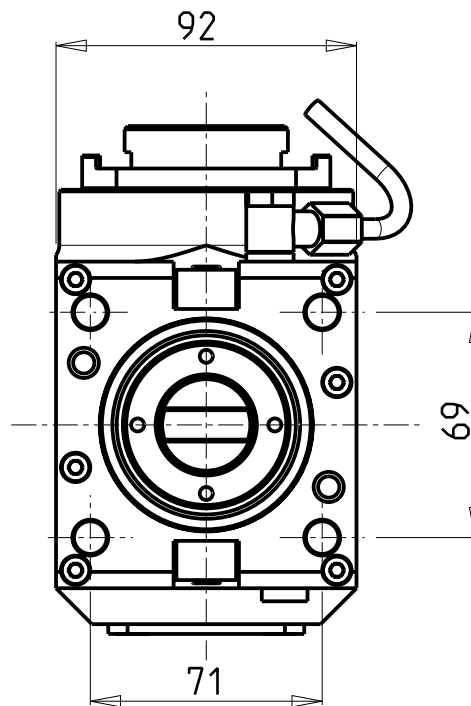
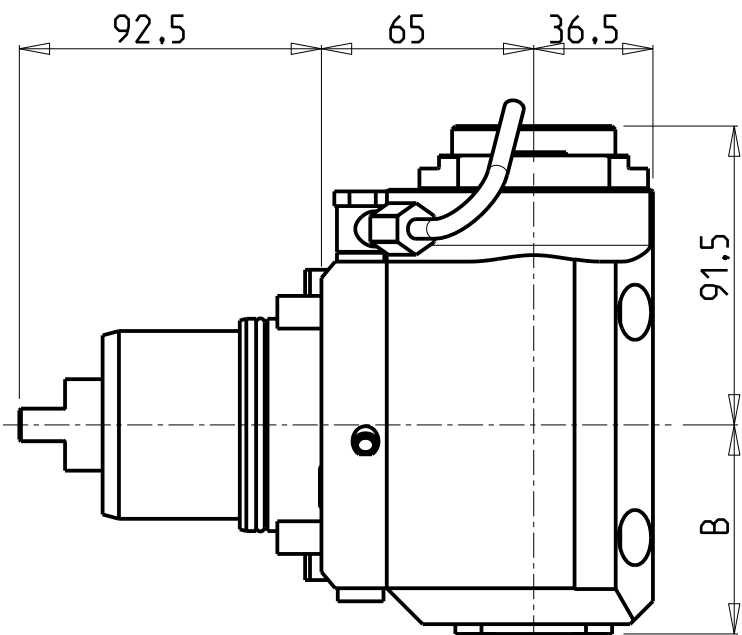

Cod. MT	Mandrino Spindle Spindel	I	RPM	Coppia Max Max Torque Max Drehmoment	Reversibile lato mandrino/contromandrino Reversible sub/main spindle side Umkehrbare Spindel-seite/ Gegenspindel-seite	Lubrificazione int. Coolant through Innenkuehlung	Lubrificazione est. Ext. coolant Aussenkuehlung	B	CHIAVI NON INCLUSE Keys not included Schlüssel nicht einbegriffen		
NKM0860325	ER A 25	1:2	12000	30Nm	X		X	64	CHUB27	CHTAER25ZC	OKU0650004
NKM0860425	ER A 25	1:2	12000	30Nm	X	P=70bar	X	74	CHUB27	CHTAER25ZC	OKU0650004

- Chiave inclusa
- Key included
- Schlüssel inbegriffen

NAKAMURA-TOME

MOD: Super Mill WT150/WT15011/WY250/SC200L - SUPER NTY3 JUMBO

MODULO MOTORIZZATO ASSIALE MOLTIPLICATO I=1:2

Axial geared-up I=1:2 driven tool

Axial angetriebenes Werkzeug uebersetzt I=1:2

Subject to change without notice.

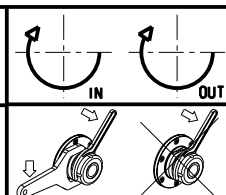

M.T. srl
Via Casino Albini 480
Tel. 0541/956034-957884
Fax 0541/956341
47842 S. GIOVANNI IN M. (RN)
e-mail: mtma@mtmarchetti.com
http://www.mtmarchetti.com

PRODUZIONE MODULI ROTANTI



PAGINA NKM200-4-10

ATTENZIONE - ATTENTION - ACHTUNG

- Per lo smontaggio degli utensili utilizzare sempre la chiave di contrasto come indicato nel manuale d'uso.
- For disassembly of the tools use always the contrast key as mentioned in the user instructions.
- Fuer das Abmontieren der Werkzeuge immer den Gegenschlüssel benutzen wie in der Bedienungsanleitung erwaeht.

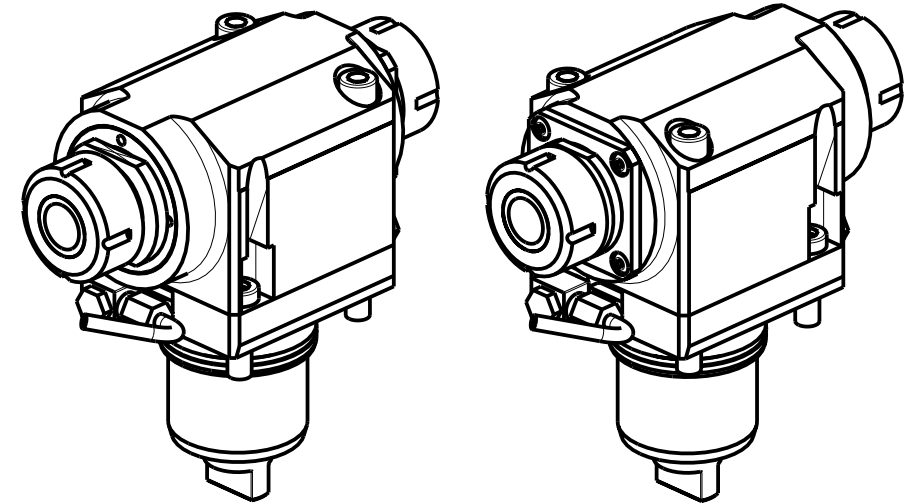
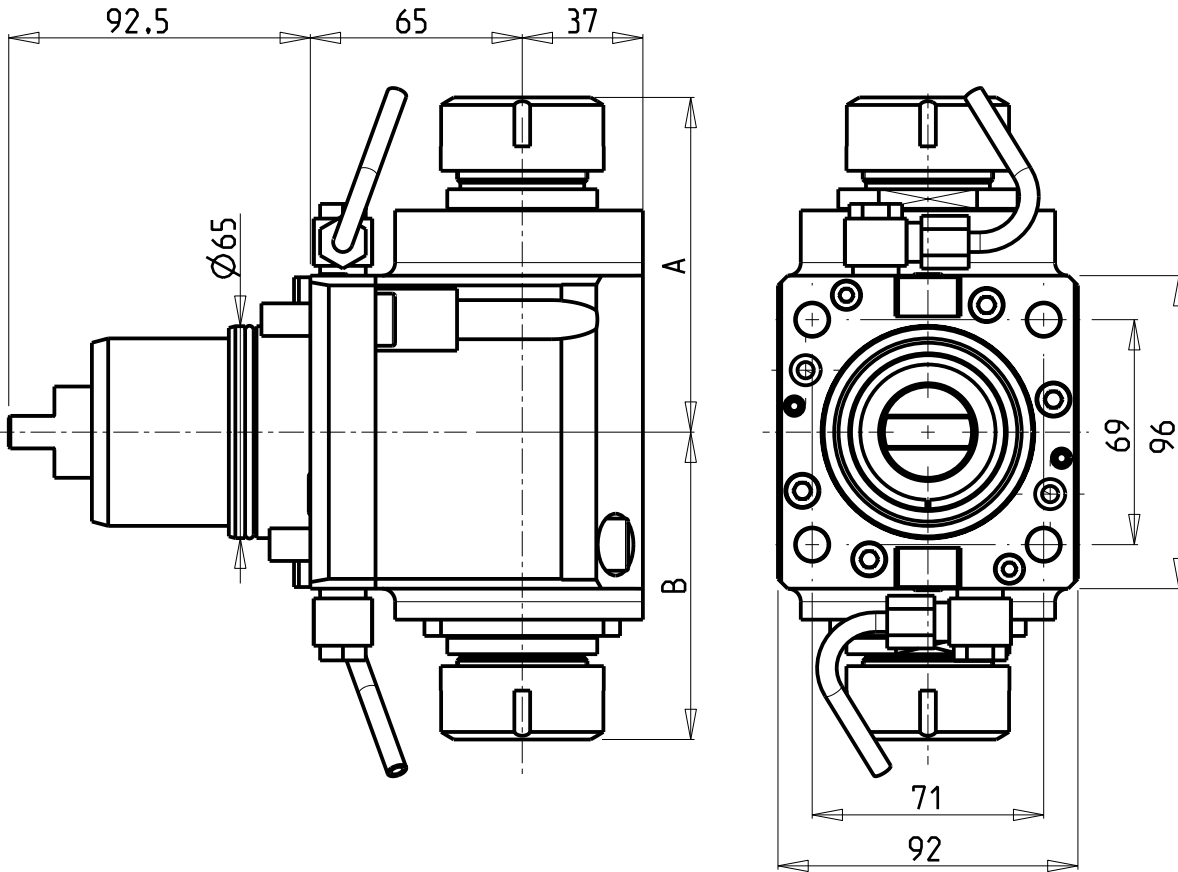

Cod. MT	Mandrino Spindle Spindel	I	RPM	Coppia Max Max Torque Max Drehmoment	Reversibile lato mandrino/contromandrino Reversible sub/main spindle side Umkehrbare Spindel-seite/ Gegenspindel-seite	Lubrificazione est. Ext. coolant Aussenkuehlung	A	B	CHIAVI NON INCLUSE Keys not included Schluessel nicht einbegriffen	
									CHSTER32	CHUB46
NKM0600232	ER32+ER32	1:1	6000	70Nm	X	X	102.66	94.26	CHSTER32	CHUB46
NKM0600240	ER40+ER40	1:1	6000	70Nm	X	X	106.16	107.16	CHSTER40	CHUB46

NAKAMURA-TOME

MOD: Super Mill WT150/WT150II/WY250/SC200L - SUPER NTY3 JUMBO

MODULO MOTORIZZATO ASSIALE BISPORGENTE H=65mm

Axial opposite face twin driven tool H=65mm

Axial angetriebenes Werkzeug halb vorspringend H=65mm

Subject to change without notice.

M.T. srl

Via Casino Albini 480
 Tel. 0541/956034-957884
 Fax 0541/956341
 47842 S. GIOVANNI IN M. (RN)
 e-mail: mtma@tmarchetti.com
 http://www.tmmarchetti.com

PRODUZIONE MODULI ROTANTI



PAGINA NKM240-4-10

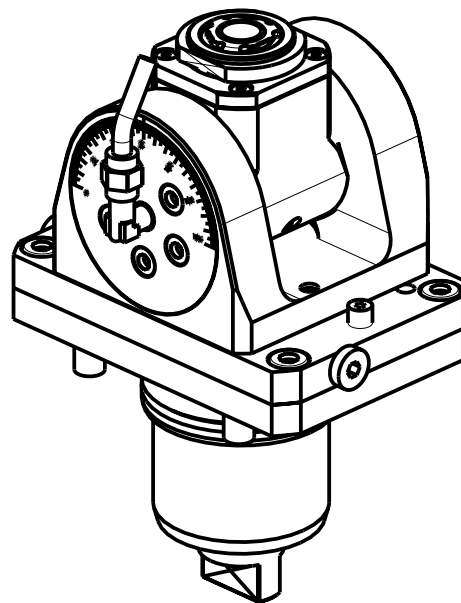
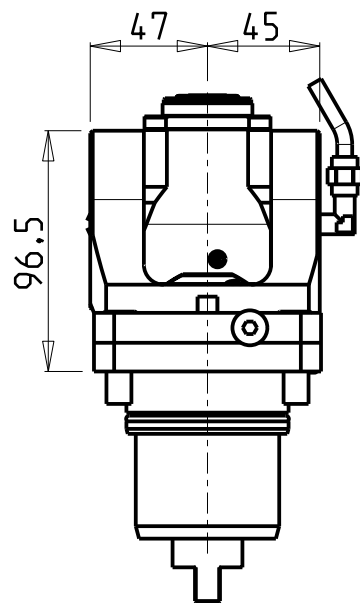
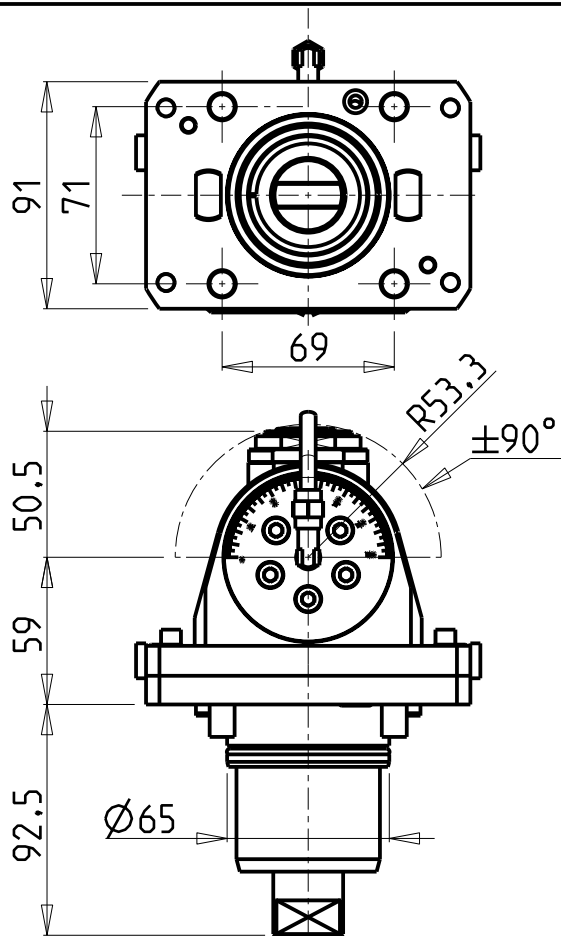

ATTENZIONE - ATTENTION - ACHTUNG

- Per lo smontaggio degli utensili utilizzare sempre la chiave di contrasto come indicato nel manuale d'uso.
- For disassembly of the tools use always the contrast key as mentioned in the user instructions.
- Fuer das Abmontieren der Werkzeuge immer den Gegenschlüssel benutzen wie in der Bedienungsanleitung erwaeht.

ATTENZIONE - ATTENTION - ACHTUNG

- Verificare la tabella sottostante per possibile interferenza su alcuni modelli di macchine
- Please check the table below for possible interferences on some machine models
- Die untenstehende tabelle unbedingt auf eventuelle interferenzen auf eingen maschinen modellen ueberpruefen

Cod. MT	Mandrino Spindle Spindel	I	RPM	Coppia Max Max Torque Max Drehmoment	Reversibile lato mandrino/contromandrino	Lubr.interna Coolant through Innenkuehlung	Lubrificazione est. Ext. coolant Aussenkuehlung	CHIAVI INCLUSE Keys included Schluessel inbegriffen				
					Reversible sub/main spindle side Umkehrbare Spindelseite/ Gegenspindelseite			CHUB22	CHUB36	CHESL05	CHESL07	CHTAER20ZC
NKM0810120	ERA20	1:1	6000	30Nm	X		X	CHUB22	CHUB36	CHESL05	CHESL07	CHTAER20ZC
NKM0810220	ERA20	1:1	6000	30Nm	X	P=70bar	X	CHUB22	CHUB36	CHESL05	CHESL07	CHTAER20ZC

NAKAMURA-TOME

MOD: Super Mill WT150/WT15011/WY250/SC200L - SUPER NTY3 JUMBO

MODULO MOTORIZZATO ORIENTABILE ±90°
 ±90° adjustable angle driven tool
 Angetriebenes Werkzeug schwenkbar ±90°

Subject to change without notice.

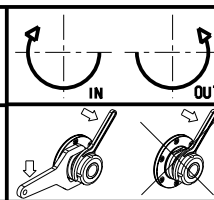

M.T. srl

Via Casino Albini 480
 Tel. 0541/956034-957884
 Fax 0541/956341
 47842 S. GIOVANNI IN M. (RN)
 e-mail: mtma@mtmarchetti.com
 http://www.mtmarchetti.com

PRODUZIONE MODULI ROTANTI



PAGINA NKM335-4-00

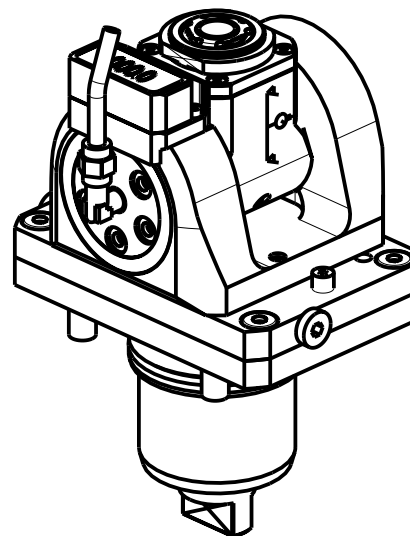
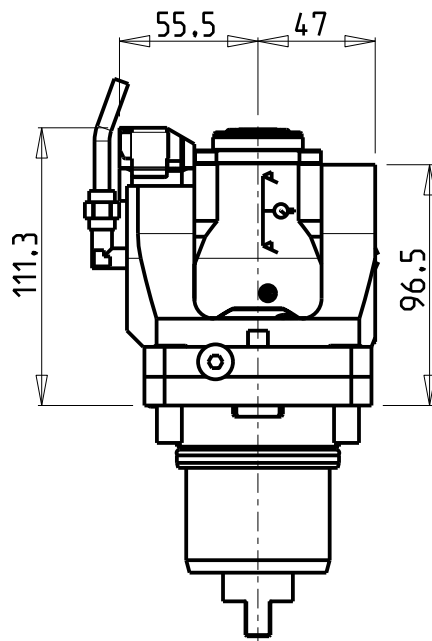
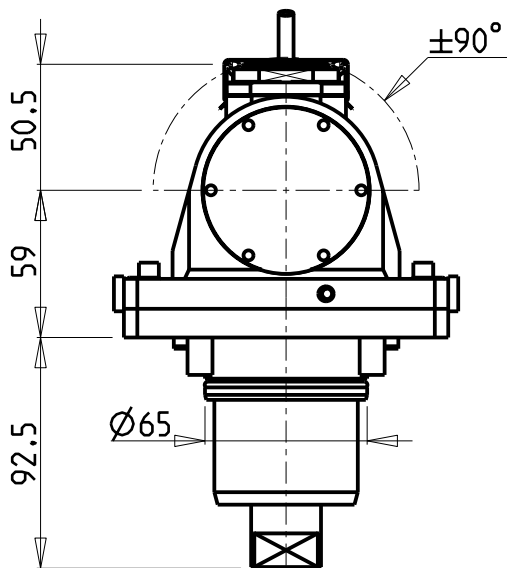
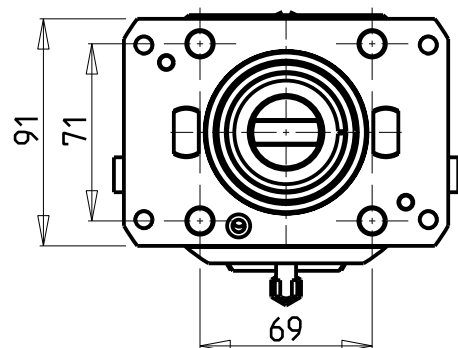

ATTENZIONE - ATTENTION - ACHTUNG

- Per lo smontaggio degli utensili utilizzare sempre la chiave di contrasto come indicato nel manuale d'uso.
- For disassembly of the tools use always the contrast key as mentioned in the user instructions.
- Fuer das Abmontieren der Werkzeuge immer den Gegenschlüssel benutzen wie in der Bedienungsanleitung erwaeht.

ATTENZIONE - ATTENTION - ACHTUNG

- Verificare la tabella sottostante per possibile interferenza su alcuni modelli di macchine
- Please check the table below for possible interferences on some machine models
- Die untenstehende tabelle unbedingt auf eventuelle interferenzen auf eingen maschinen modellen überprüfen

Cod. MT	Mandrino Spindle Spindel	I	RPM	Coppia Max Max Torque Max Drehmoment	Reversibile lato mandrino/contromandrino	Lubr.interna Coolant through Innenkuehlung	Lubrificazione est. Ext. coolant Aussenkuehlung	CHIAVI INCLUSE Keys included Schluessel inbegriffen				
					Reversible sub/main spindle side Umkehrbare Spindelseite/ Gegenspindelseite							
NKM0815120	ERA20	1:1	6000	30Nm	X	-	X	CHUB22	CHUB36	CHESL05	CHESL07	CHTAER20ZC
NKM0815220	ERA20	1:1	6000	30Nm	X	P=70bar	X	CHUB22	CHUB36	CHESL05	CHESL07	CHTAER20ZC

NAKAMURA-TOME

MOD: Super Mill WT150/WT15011/WY250/SC200L - SUPER NTY3 JUMBO

MODULO MOTORIZZATO ORIENTABILE ±90° CON NONIO DIGITALE

±90° adjustable angle driven tool with digital display

Angetriebenes Werkzeug schwenkbar ±90° mit digital display

Subject to change without notice.

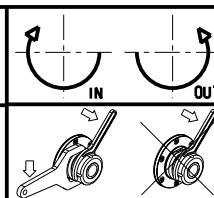

M.T. srl

Via Casino Albini 480
Tel. 0541/956034-957884
Fax 0541/956341
47842 S. GIOVANNI IN M. (RN)
e-mail: mtma@mtmarchetti.com
http://www.mtmarchetti.com

PRODUZIONE MODULI ROTANTI



PAGINA NKM335-4-01

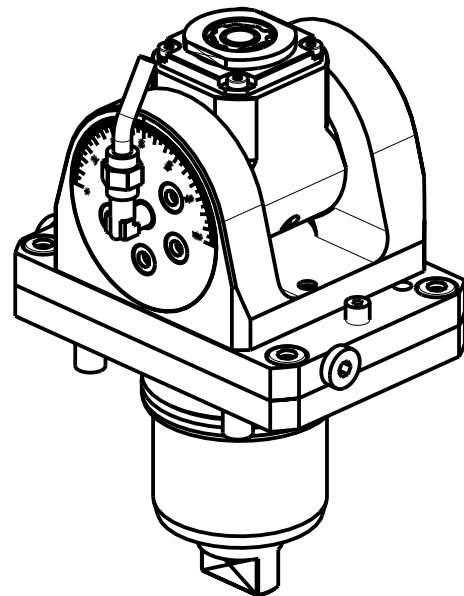
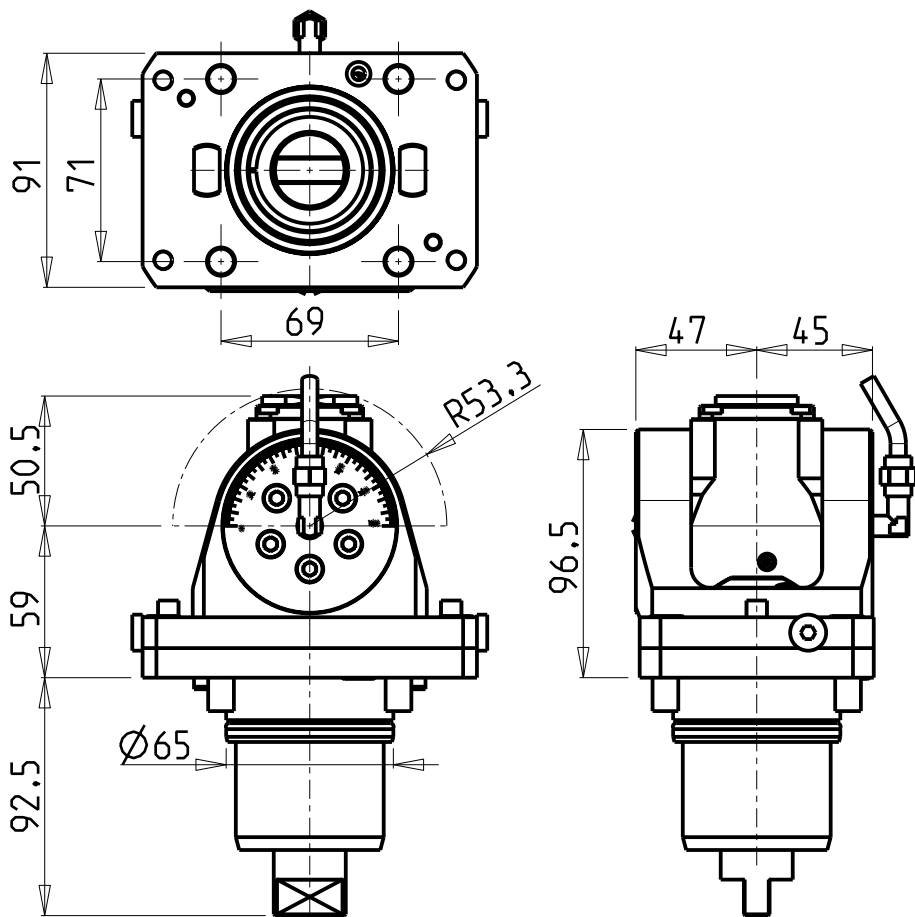

ATTENZIONE - ATTENTION - ACHTUNG

- Per lo smontaggio degli utensili utilizzare sempre la chiave di contrasto come indicato nel manuale d'uso.
- For disassembly of the tools use always the contrast key as mentioned in the user instructions.
- Fuer das Abmontieren der Werkzeuge immer den Gegenschlüssel benutzen wie in der Bedienungsanleitung erwäehnt.

ATTENZIONE - ATTENTION - ACHTUNG

- Verificare la tabella sottostante per possibile interferenza su alcuni modelli di macchine
- Please check the table below for possible interferences on some machine models
- Die untenstehende tabelle unbedingt auf eventuelle interferenzen auf eingen maschinen modellen überprüfen

Cod. MT	Mandrino Spindle Spindel	i	RPM	Coppia Max Max Torque Max Drehmoment	Reversibile lato mandrino/contromandrino Reversible sub/main spindle side Umkehrbare Spindel-seite/ Gegenspindel-seite	Lubr.interna Coolant through Innenkuehlung	Lubrificazione est. Ext. coolant Aussenkuehlung	CHIAVI INCLUSE Keys included Schluessel inbegriffen				
					X		X	CHUB19_SP3	CHUB32	CHESL05	CHESL07	CHTAER16ZC
NKM0810316	ERA16	1:2	12000	8Nm	X		X	CHUB19_SP3	CHUB32	CHESL05	CHESL07	CHTAER16ZC
NKM0810416	ERA16	1:2	12000	8Nm	X	P=70bar	X	CHUB19_SP3	CHUB32	CHESL05	CHESL07	CHTAER16ZC

NAKAMURA-TOME

MOD: Super Mill WT150/WT15011/WY250/SC200L - SUPER NTY3 JUMBO

MODULO MOTORIZZATO ORIENTABILE +/-90° MOLTIPLICATO I=1:2

+/-90° adjustable angle driven tool geared-up I=1:2

Angetriebenes Werkzeug schwenkbar +/-90° uebersetzt I=1:2

Subject to change without notice.

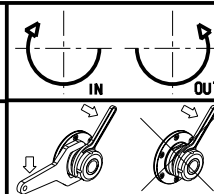

M.T. srl

Via Casino Albini 480
Tel. 0541/956034-957884
Fax 0541/956341
47842 S. GIOVANNI IN M. (RN)
e-mail: mtma@mtmarchetti.com
http://www.mtmarchetti.com

PRODUZIONE MODULI ROTANTI



PAGINA NKM336-4-00

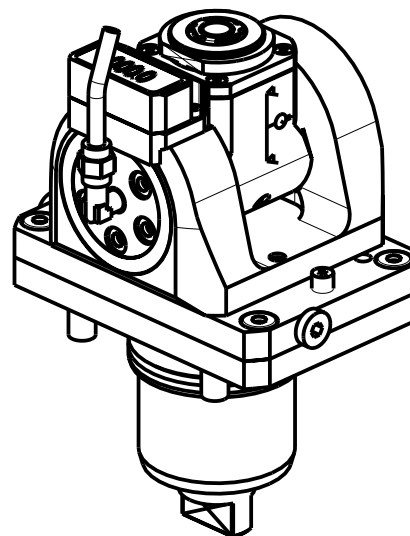
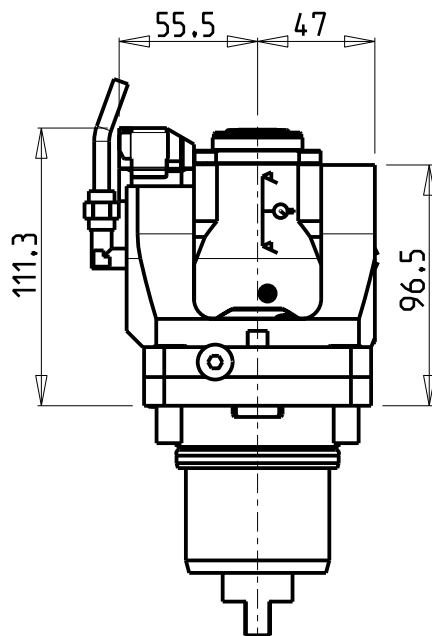
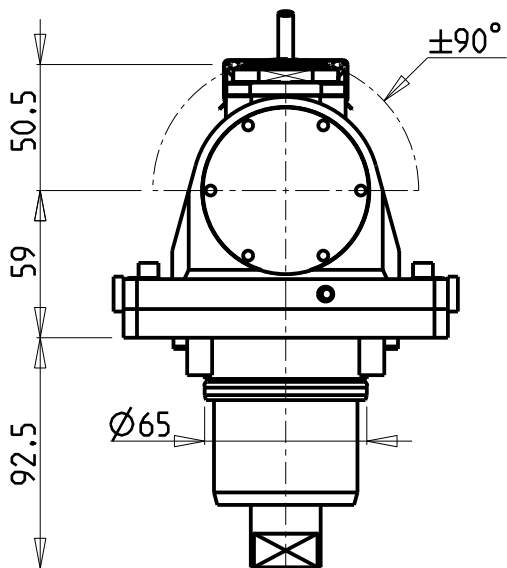
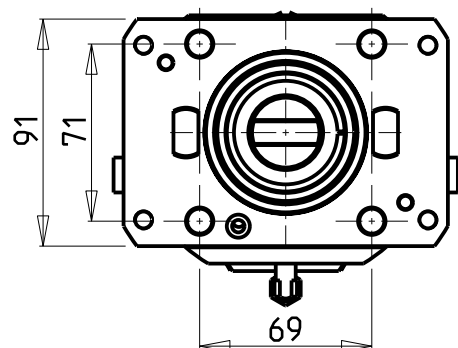

ATTENZIONE - ATTENTION - ACHTUNG

- Per lo smontaggio degli utensili utilizzare sempre la chiave di contrasto come indicato nel manuale d'uso.
- For disassembly of the tools use always the contrast key as mentioned in the user instructions.
- Fuer das Abmontieren der Werkzeuge immer den Gegenschlüssel benutzen wie in der Bedienungsanleitung erwaeht.

ATTENZIONE - ATTENTION - ACHTUNG

- Verificare la tabella sottostante per possibile interferenza su alcuni modelli di macchine
- Please check the table below for possible interferences on some machine models
- Die untenstehende tabelle unbedingt auf eventuelle interferenzen auf eingen maschinen modellen ueberpruefen

Cod. MT	Mandrino Spindle Spindel	I	RPM	Coppia Max Max Torque Max Drehmoment	Reversibile lato mandrino/contromandrino	Lubr.interna Coolant through Innenkuehlung	Lubrificazione est. Ext. coolant Aussenkuehlung	CHIAVI INCLUSE Keys included Schluessel inbegriffen				
					Reversible sub/main spindle side Umkehrbare Spindelseite/ Gegenspindelseite			C HUB19_SP3	C HUB32	C HESL05	C HESL07	C HTAER16ZC
NKM0815316	ERA16	1:2	12000	8Nm	X	-	X	C HUB19_SP3	C HUB32	C HESL05	C HESL07	C HTAER16ZC
NKM0815416	ERA16	1:2	12000	8Nm	X	P=70bar	X	C HUB19_SP3	C HUB32	C HESL05	C HESL07	C HTAER16ZC

NAKAMURA-TOME

MOD: Super Mill WT150/WT15011/WY250/SC200L - SUPER NTY3 JUMBO

MODULO MOTORIZZATO ORIENTABILE +/-90° MOLTIPLICATO I=1:2 CON NONIO DIGITALE

+/-90° adjustable angle driven tool geared-up I=1:2 with digital display

Angetriebenes Werkzeug schwenkbar +/-90° uebersetzt I=1:2 mit digital display

Subject to change without notice.

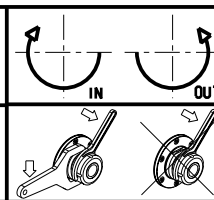

M.T. srl

Via Casino Albini 480
Tel. 0541/956034-957884
Fax 0541/956341
47842 S. GIOVANNI IN M. (RN)
e-mail: mtma@mtmarchetti.com
http://www.mtmarchetti.com

PRODUZIONE MODULI ROTANTI



PAGINA NKM336-4-01

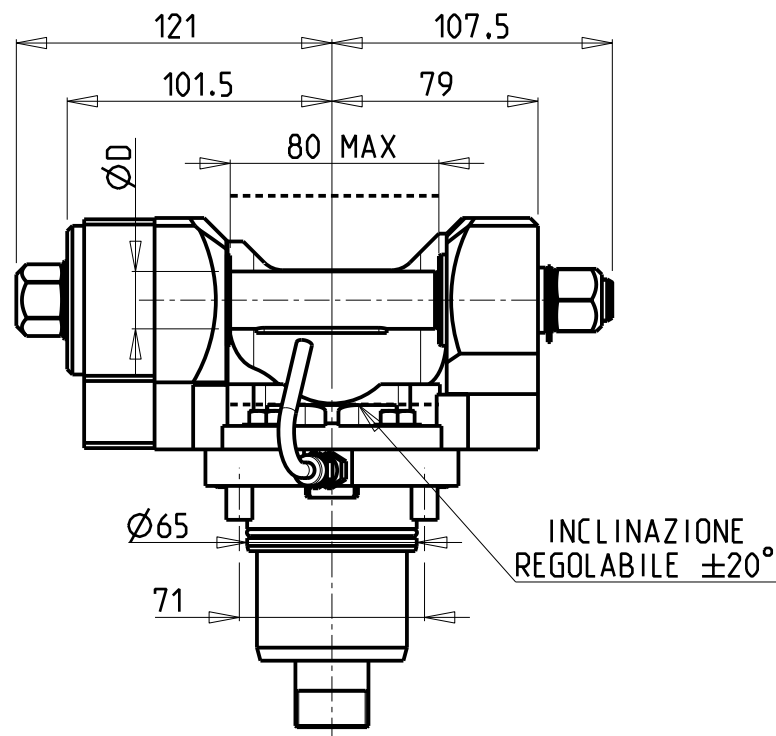
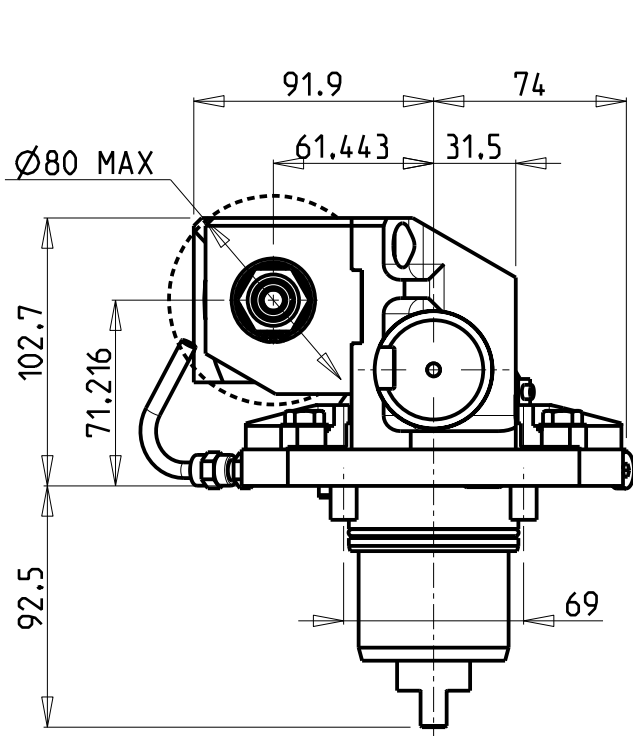

ATTENZIONE - ATTENTION - ACHTUNG

- FUORI VOLTEGGIO!
- OUT OF MAXIMUM SWING!
- WERKZEUG AUSSER INTERFERENZ!

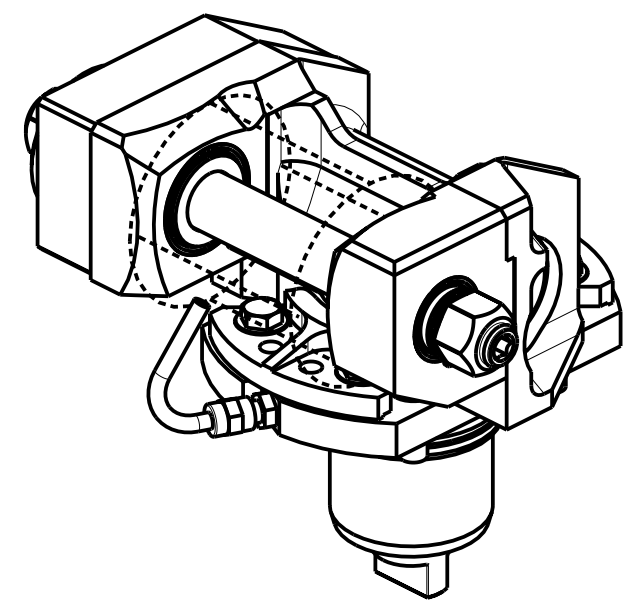

DOTAZIONI - SUPPLIED WITH - AUSSTATTUNG

- N°1 ALBERO + DISTANZIALI
- N°1 SHAFT + SPACER
- N°1 DORN + ABSTANDSSTUECK

PER ALBERI E DISTANZIALI VEDI PAG. TBL250-1-00
 FOR SHAFT END SPACER SEE PAGE TBL250-1-00
 FUER DORN UND ABSTANDSSTUECK SEITE TBL250-1-00

Cod. MT	i	RPM max	Coppia Max Max Torque Max Drehmoment	Reversibile lato mandrino/contromandrino Reversible sub/main spindle side Umkehrbare Spindel-seite/ Gegenspindel-seite	Lubrificazione est. Ext. coolant Aussenkuehlung	D (mm)	D (Inch)	CHIAVI INCLUSE Keys included Schlüssel inbegriffen			
								CHUB13	CHUB24	CHESL08	CHESL07
NKM0331100	1:1	6000	60Nm	X	X	16-22-27-32	3/4"-1"-1 1/4"	CHUB13	CHUB24	CHESL08	CHESL07
NKM0332100	2:1	3000	80Nm	X	X	16-22-27-32	3/4"-1"-1 1/4"	CHUB13	CHUB24	CHESL08	CHESL07

NAKAMURA-TOME

MOD: Super Mill WT150/WT15011/WY250/SC200L - SUPER NTY3 JUMBO

MODULO MOTORIZZATO PORTACREATORE

Driven gear hobber

Angetriebenes Zahnradwaeltzraes-Werkzeug

Subject to change without notice.

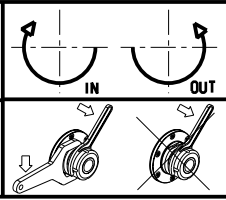

M.T. srl
 Via Casino Albini 480
 Tel. 0541/956034-957884
 Fax 0541/956341
 47842 S. GIOVANNI IN M. (RN)
 e-mail: mtma@tmarchetti.com
 http://www.tmmarchetti.com

PRODUZIONE MODULI ROTANTI



PAGINA NKM340-4-00

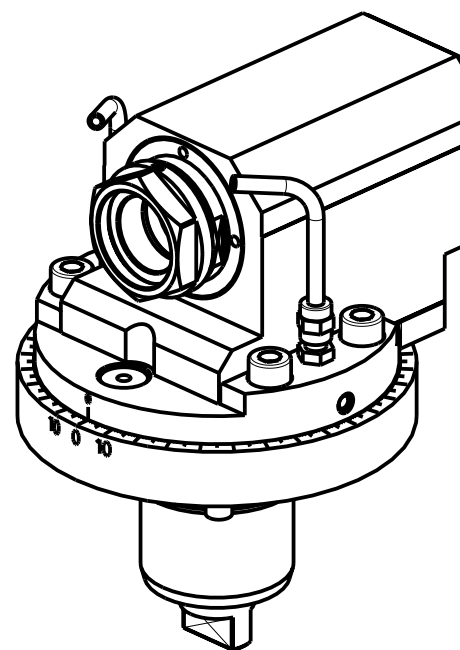
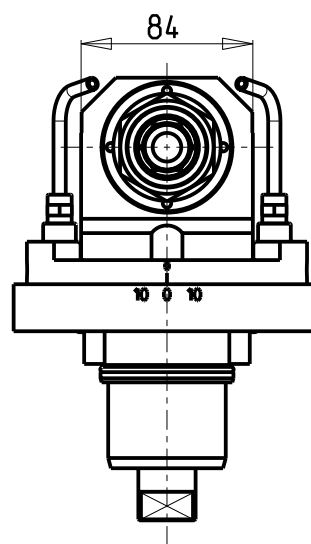
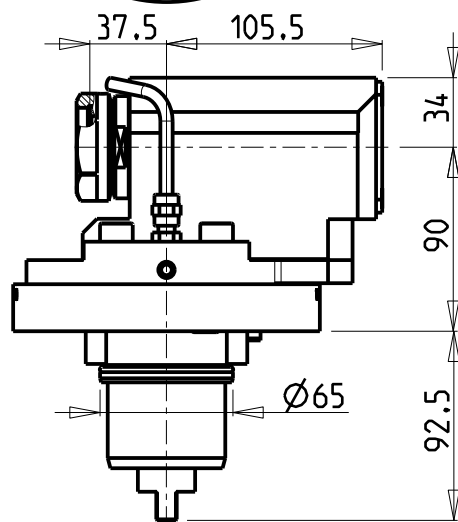
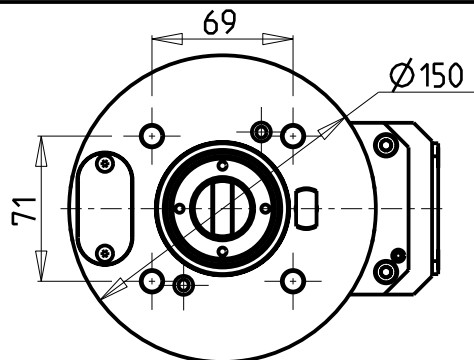

ATTENZIONE - ATTENTION - ACHTUNG

- VERIFICARE LE MISURE DI INGOMBRO PER POSSIBILE INTERFERENZA SU ALCUNI MODELLI DI MACCHINE
- Please check the overall sizes for possible interferences on some machine models
- Bitte überprüfen sie das ausmass um mögliche interferenzen auf einigen maschinen modellen zu vermeiden

PER PORTAUTENSILI MODULARI MTSK-40 VEDI PAG. TBL300-1-40
 FOR MTSK-40 QUICK CHANGE TOOLHOLDERS CLAMPINGS SEE PAGE TBL300-1-40
 FUER MTSK-40 MODULARE WERKZEUGAUFNAHMEN SIEHE SEITE TBL300-1-40

Cod. MT	Mandrino Spindle Spindel	I	RPM	Coppia Max Max Torque Max Drehmoment	Reversibile lato mandrino/contromandrino Reversible sub/main spindle side Umkehrbare Spindel-seite/Gegenspindel-seite	Lubr.esterna Ext. coolant Aussenkuehlung	CHIAVI INCLUDE Keys included Schluessel einbegriffen
NKM1170100	MTSK-40	1:1	6000	50Nm	X	X	n°2 CHUB46

NAKAMURA-TOME

MOD: Super Mill WT150/WT15011/WY250/SC200L - SUPER NTY3 JUMBO

MODULO MOTORIZZATO ASSIALE MTSK PER POWER SKIVING H=90mm

Axial MTSK driven tool for Power Skiving H=90mm

Axial MTSK angetriebenes Werkzeug fuer Power Skiving H=90mm

Subject to change without notice.

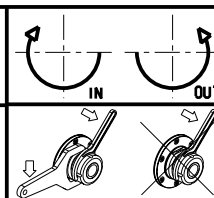

M.T. srl

Via Casino Albini 480
 Tel. 0541/956034-957884
 Fax 0541/956341
 47842 S. GIOVANNI IN M. (RN)
 e-mail: mtma@mtmarchetti.com
 http://www.mtmarchetti.com

PRODUZIONE MODULI ROTANTI



PAGINA NKM350-4-00-K

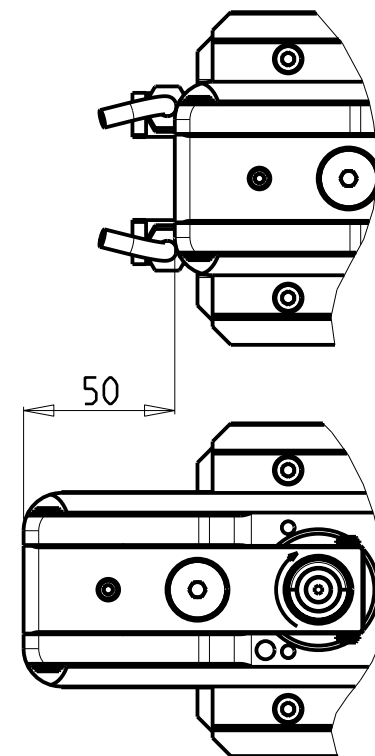
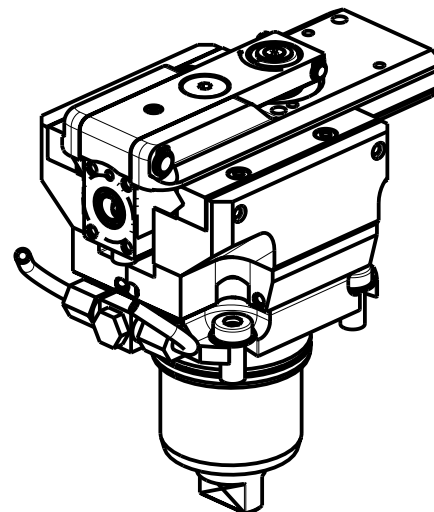
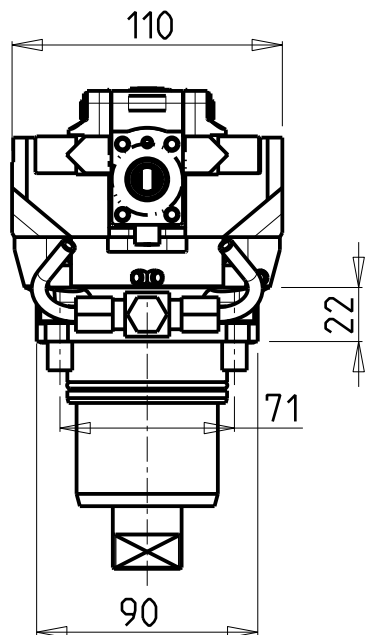
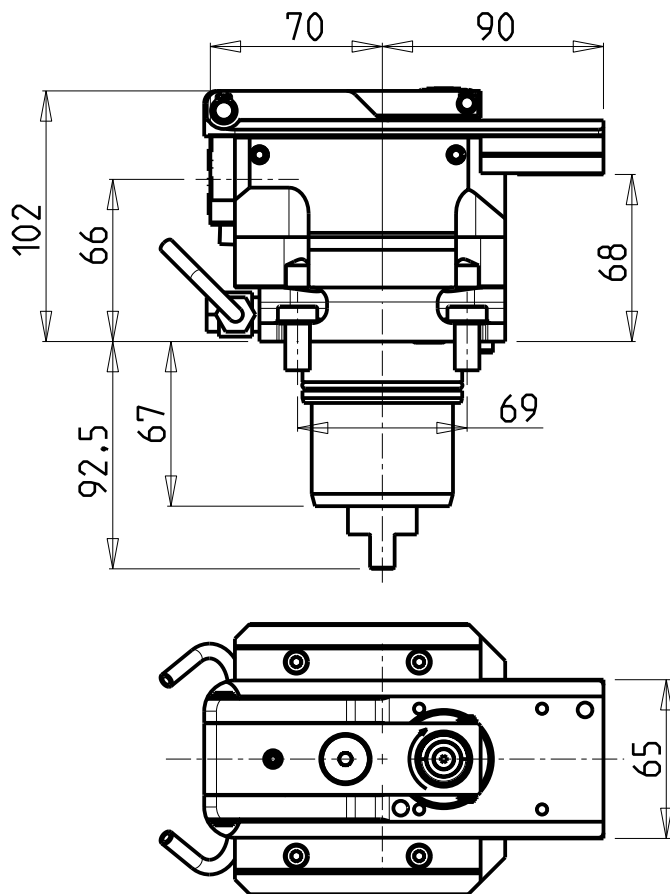

PER UTENSILI STOZZATORI VEDI PAG. TBL400-1-00
 FOR DRIVEN SLOTTING TOOL CUTTING-TOOLS SEE PAGE TBL400-1-00
 FÜR NUTENSTOSS-WERKZEUG SCHNEIDWERKZEUGE SIEHE SEITE TBL400-1-00

Cod. MT	I	RPM MAX	Reversibile lato mandrino/contromandrino Reversible sub/main spindle side Umkehrbare Spindel-seite/ Gegenspindel-seite	Lubr. esterna Ext. coolant Aussenkuehlung
NKM0940100	4:1	2000	X	X

NAKAMURA-TOME

MOD: Super Mill WT150/WT15011/WY250/SC200L - SUPER NTY3 JUMBO

MODULO MOTORIZZATO STOZZATORE CORSA 50mm

Slotting driven tool 50mm stroke

Keilnutenstossmaschine 50mm Hub

Subject to change without notice.

M.T. srl

Via Casino Albini 480
 Tel. 0541/956034-957884
 Fax 0541/956341
 47842 S. GIOVANNI IN M. (RN)
 e-mail: mtma@mtmarchetti.com
 http://www.mtmarchetti.com

PRODUZIONE MODULI ROTANTI



PAGINA NKM360-4-00

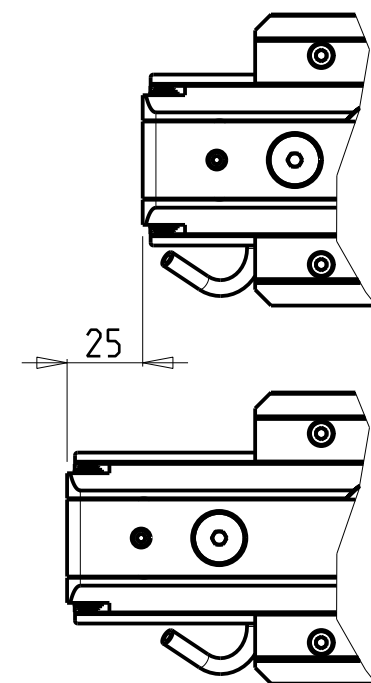
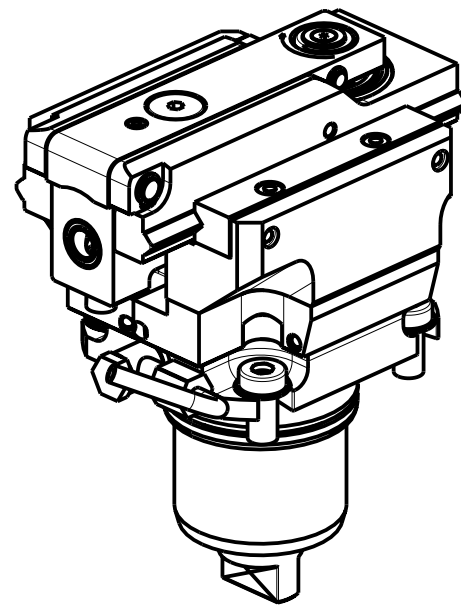
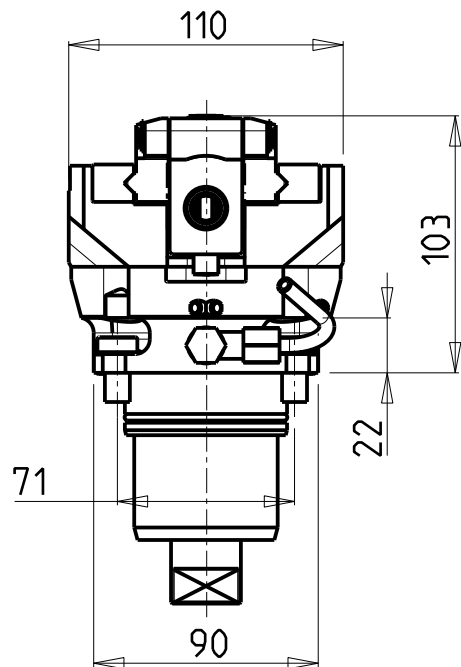
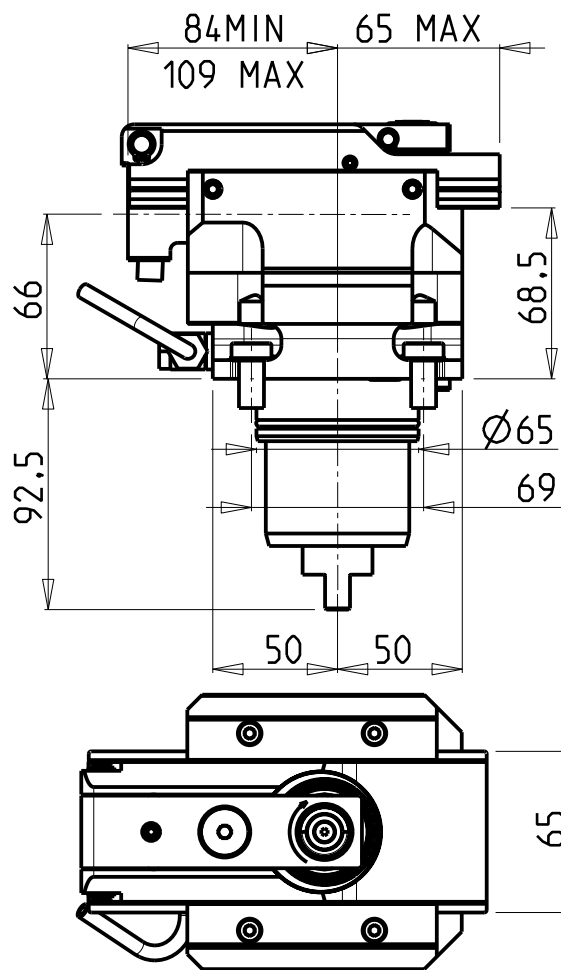

PER UTENSILI STOZZATORI VEDI PAG. TBL400-1-00
 FOR DRIVEN SLOTTING TOOL CUTTING-TOOLS SEE PAGE TBL400-1-00
 FÜR NUTENSTOSS-WERKZEUG SCHNEIDEWERKZEUGE SIEHE SEITE TBL400-1-00

Cod. MT	I	RPM MAX	Reversibile lato mandrino/contromandrino Reversible sub/main spindle side Umkehrbare Spindel-seite/ Gegenspindel-seite	Lubr. esterna Ext. coolant Aussenkuehlung
NKM0940200	4:1	2400	X	X

NAKAMURA-TOME

MOD: Super Mill WT150/WT15011/WY250/SC200L - SUPER NTY3 JUMBO

MODULO MOTORIZZATO STOZZATORE CORSA 25mm

Slotting driven tool 25mm stroke

Keilnutenstossmaschine 25mm Hub

Subject to change without notice.

M.T. srl

Via Casino Albini 480
 Tel. 0541/956034-957884
 Fax 0541/956341
 47842 S. GIOVANNI IN M. (RN)
 e-mail: mtma@mtmarchetti.com
 http://www.mtmarchetti.com

PRODUZIONE MODULI ROTANTI



PAGINA NKM360-4-01

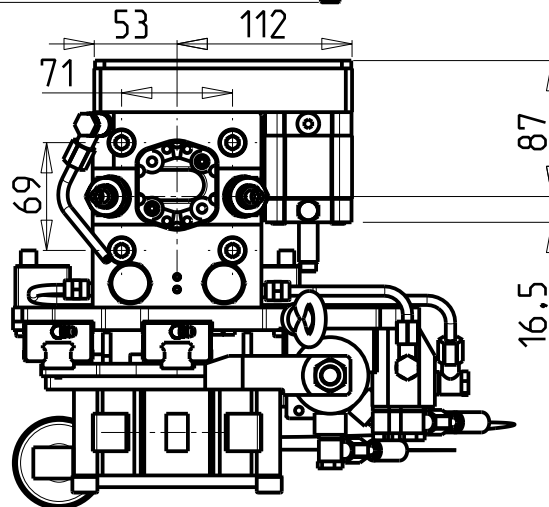
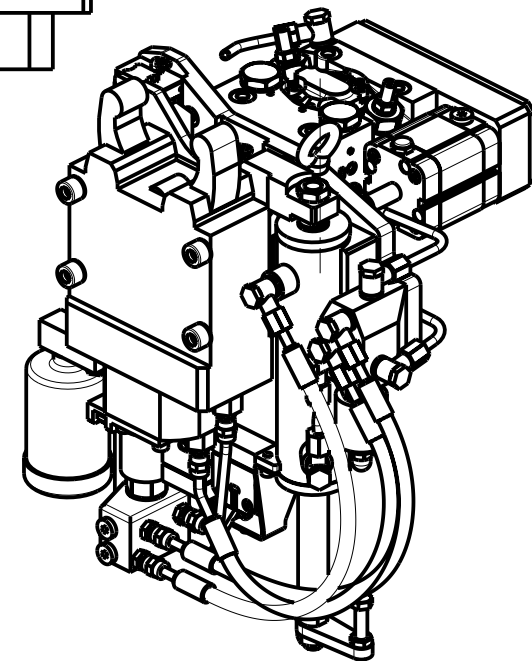
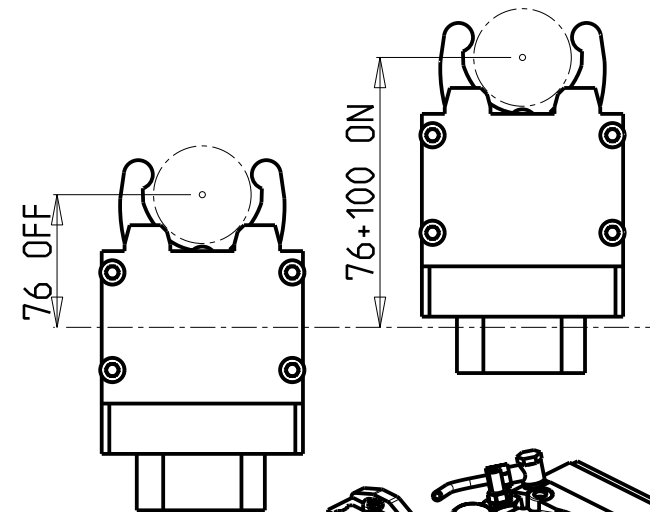
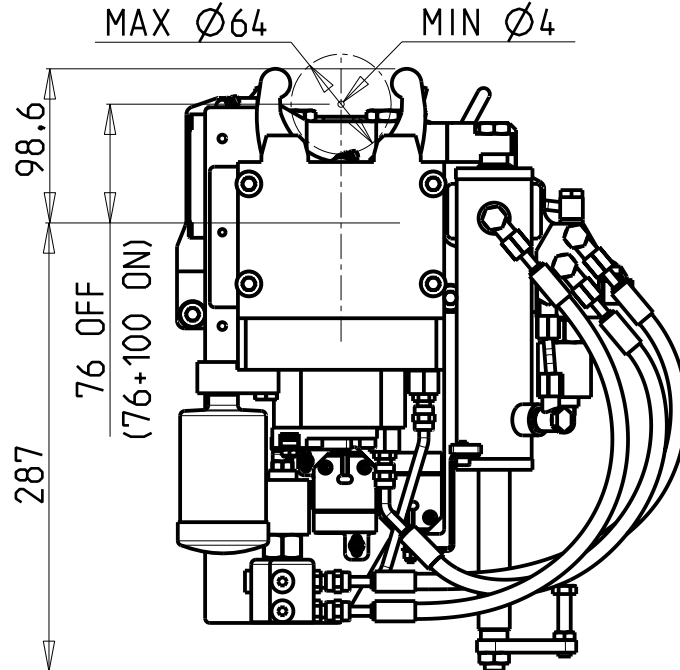
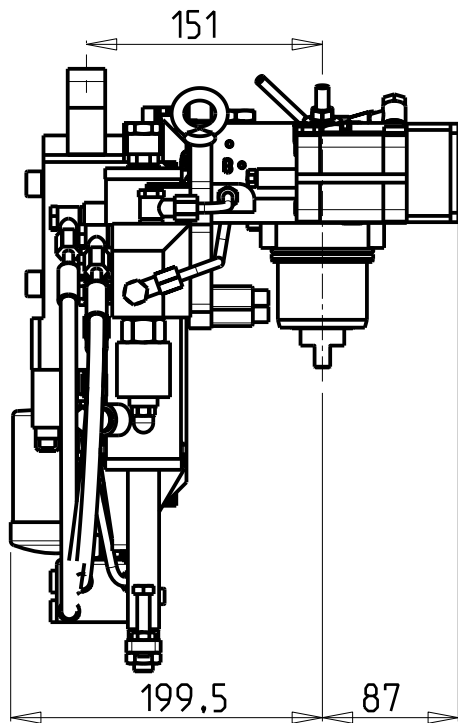

(())	#	CON GESTIONE ELETTRONICA APERTURA COMPLETA DELLA LUNETTA
	#	With Electronic control of steady rest arms complete opening
	#	Mit vollstaendiger elektronischer Oeffnungsbedienung der Luenette

Cod. MT	I	RPM	Lubr.esterna Ext. coolant Aussenkuehlung
NKM0820300	1:1	6000	X
# NKM0820300EU	1:1	6000	X
# NKM0820300US	1:1	6000	X

PER U.S.A.-AUSTRALIA-CANADA
For U.S.A.-Australia-Canada
Fuer U.S.A.-Australien-Kanada

NAKAMURA-TOME

MOD: Super Mill WT150/W T150II/W Y250 - SUPER NTY3 JUMBO

MODULO MOTORIZZATO PER LUNETTA RETRATTILE (TAGLIA 1)

Driven toolholder for sliding steady rest (Size 1)

Luenettenwerkzeug zurueck versetzte Version (Grossse 1)

Subject to change without notice.

M.T. srl

Via Casino Albini 480
Tel. 0541/956034-957884
Fax 0541/956341
47842 S. GIOVANNI IN M. (RN)
e-mail: mtma@mtmarchetti.com
http://www.mtmarchetti.com

PRODUZIONE MODULI ROTANTI



PAGINA NKM363-4-00

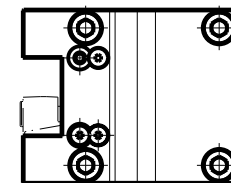
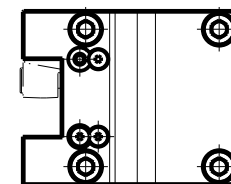
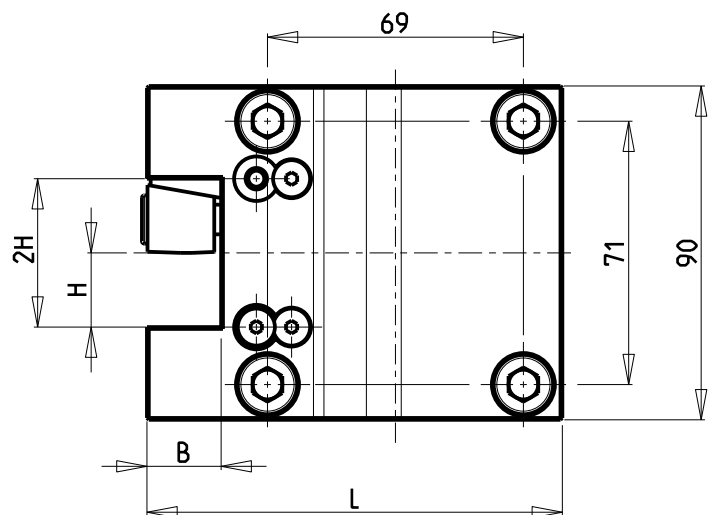
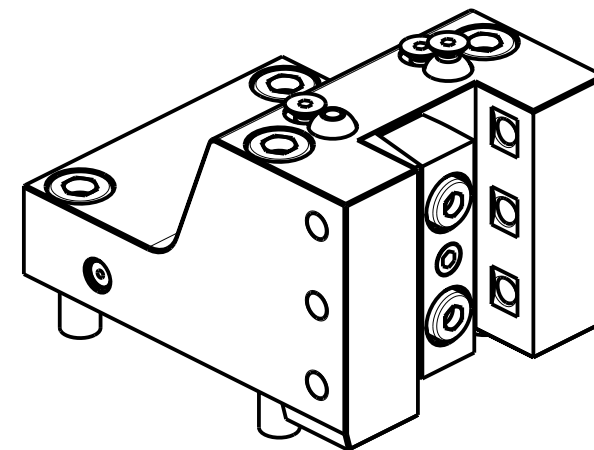
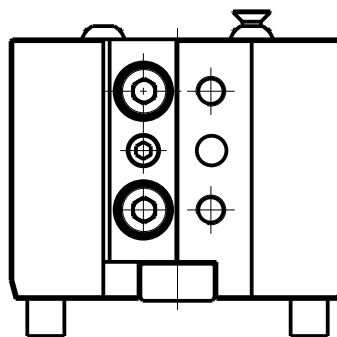
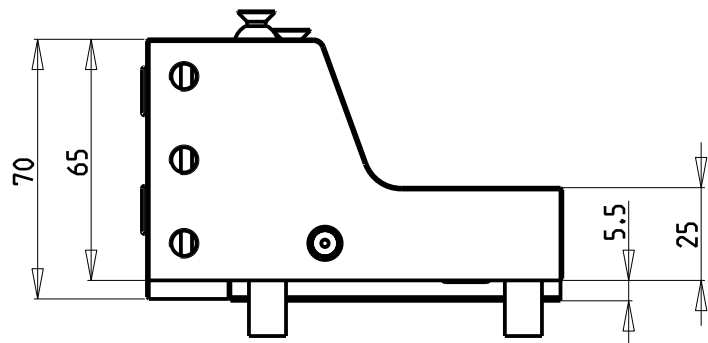

Cod. MT	Cod. NAKAMURA	N°Utensili N°Tools N°Werkzeuge	Reversibile lato mandrino/contromandrino Reversible sub/main spindle side Umkehrbare Spindel-seite/ Gegenspindel-seite	L	B	H
NKM0412000	G31510/G31520	1/2	X	112	20	20
NKM0412500	G31410/G31420	1/2	X	117	25	25

NAKAMURA - TOME

MOD: Super Mill WT150/WT15011/WY250/SC200L - SUPER NTY3 JUMBO

PORTAUTENSILE RADIALE SINGOLO QD=20mm / QD=25mm

Radial single static tool QD=20mm / QD=25mm

Radial Single-Werkzeughalter QD=20mm / QD=25mm

Subject to change without notice.

M.T. srl

Via Casino Albini 480
Tel. 0541/956034-957884
Fax 0541/956341

47842 S. GIOVANNI IN M. (RN)
e-mail: mtma@mtmarchetti.com
http://www.mtmarchetti.com

PRODUZIONE MODULI ROTANTI



PAGINA NKM423-4-00

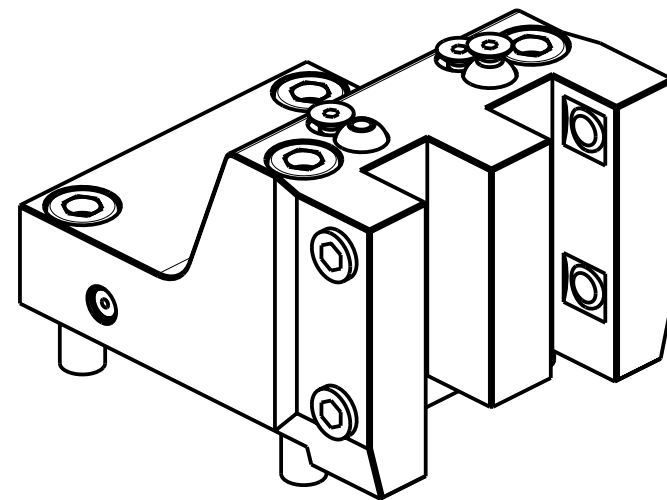
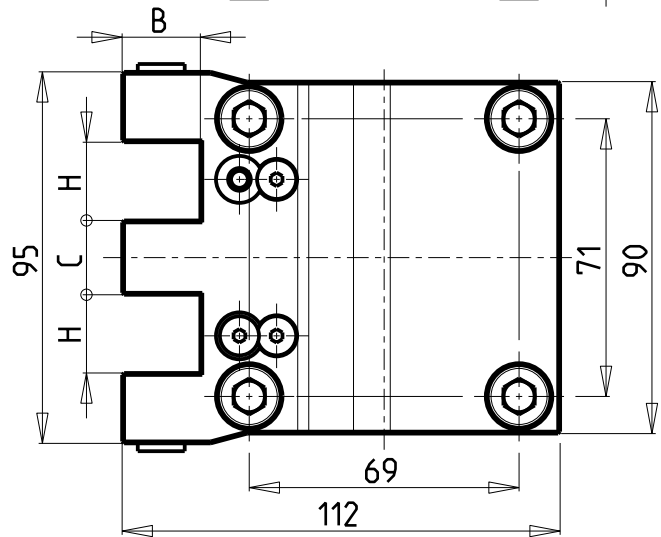
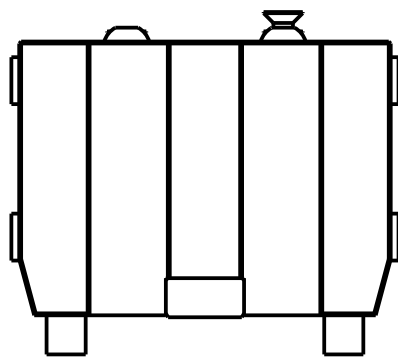
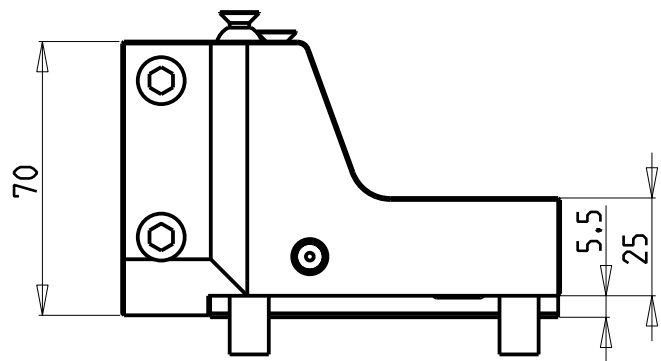

Cod. MT	N°Utensili N°Tools N°Werkzeuge	Reversibile lato mandrino/contromandrino Reversible sub/main spindle side Umkehrbare Spindel-seite/ Gegenspindel-seite	Misure Dimensions Masse	B	H	C
NKM0362000	2	X	mm	20	20	19
NKM0361905	2	X	inch	3/4"	3/4"	19 (mm)

NAKAMURA-TOME

MOD: Super Mill WT150/WT15011/WY250/SC200L - SUPER NTY3 JUMBO

PORTAUTENSILE RADIALE SOVRAPPOSTO QD=20mm / QD=3/4"

Radial single side twin static tool QD=20mm / QD=3/4"

Radial Werkzeughalter ueberlagert QD=20mm / QD=3/4"

Subject to change without notice.

M.T. srl

Via Casino Albini 480
Tel. 0541/956034-957884
Fax 0541/956341
47842 S. GIOVANNI IN M. (RN)
e-mail: mtma@mtmarchetti.com
http://www.mtmarchetti.com

PRODUZIONE MODULI ROTANTI



PAGINA NKM440-4-00

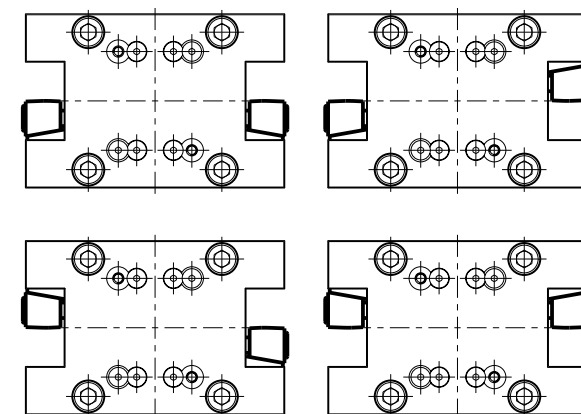
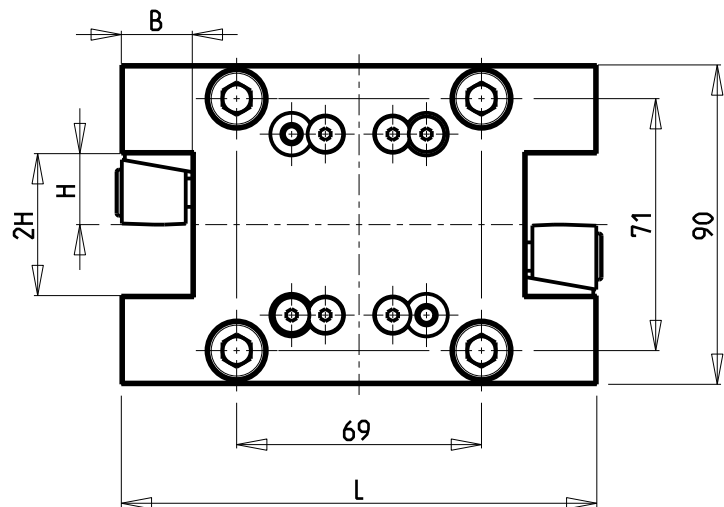
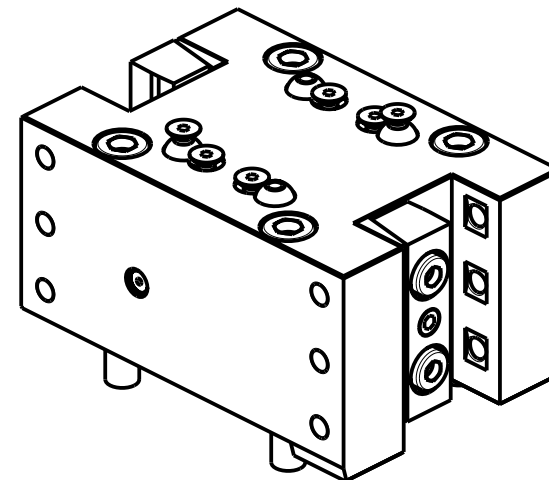
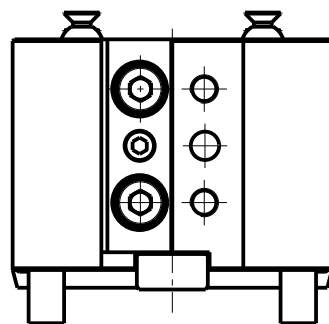
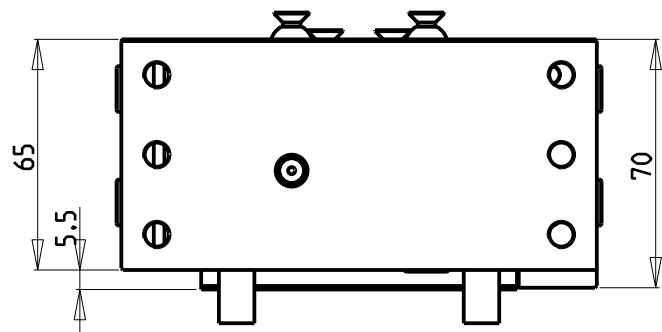

Cod. MT	N°Utensili N°Tools N°Werkzeuge	Reversibile lato mandrino/contromandrino Reversible sub/main spindle side Umkehrbare Spindel-seite/ Gegenspindel-seite	L	B	H
NKM0422000	2	X	134	20	20
NKM0422500	2	X	144	25	25

NAKAMURA-TOME

MOD: Super Mill WT150/WT15011/WY250/SC200L - SUPER NTY3 JUMBO

PORTAUTENSILE RADIALE DOPPIO QD=20mm / QD=25mm

Radial double static tool QD=20mm / QD=25mm

Radial Doppel-Werkzeughalter QD=20mm / QD=25mm

Subject to change without notice.

M.T. srl

Via Casino Albini 480
Tel. 0541/956034-957884
Fax 0541/956341
47842 S. GIOVANNI IN M. (RN)
e-mail: mtma@mtmarchetti.com
<http://www.mtmarchetti.com>

PRODUZIONE MODULI ROTANTI



PAGINA NKM453-4-00

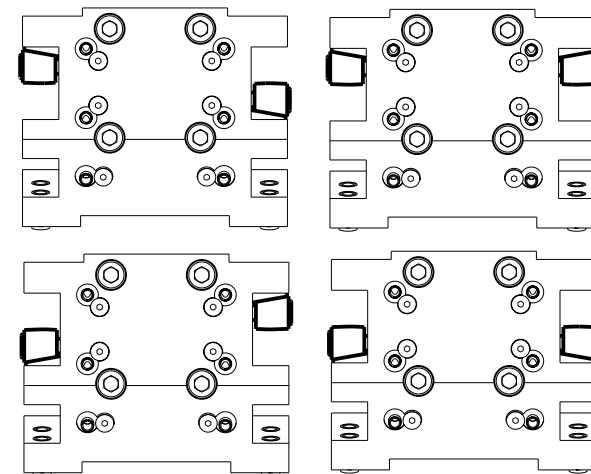
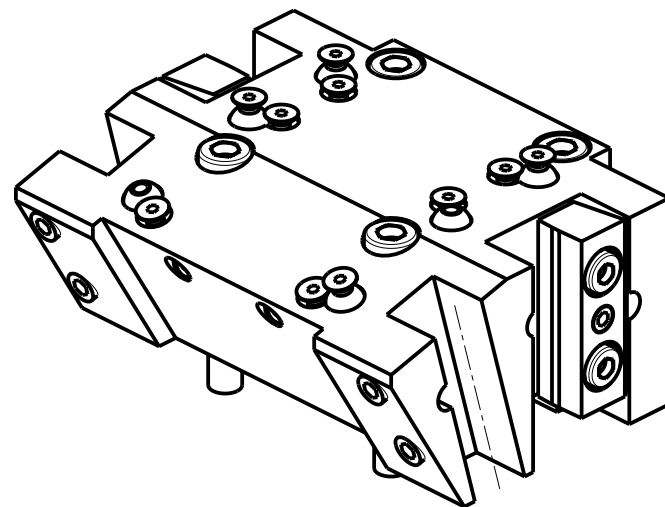
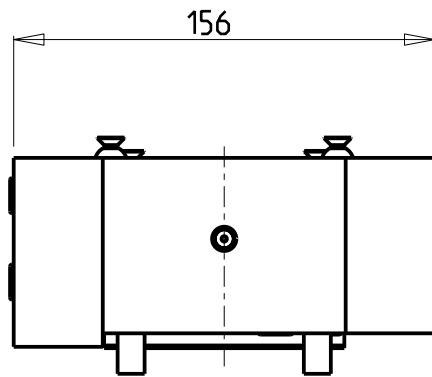
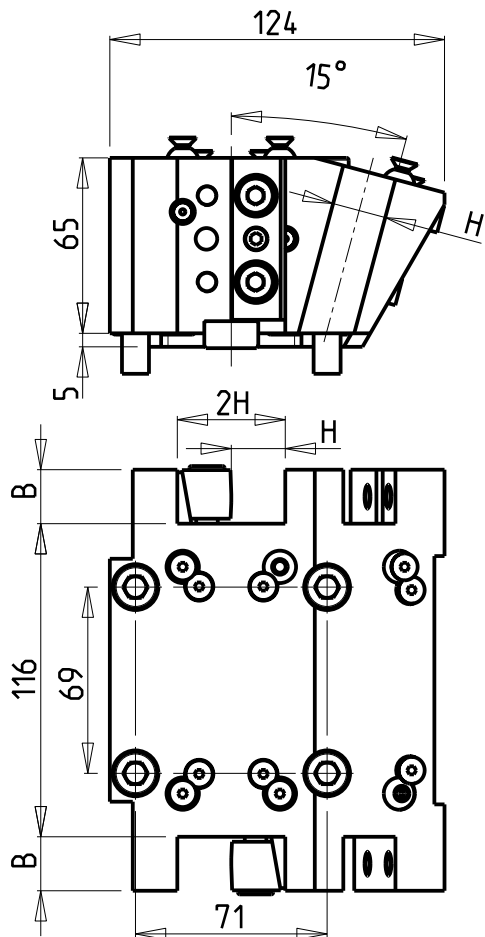

Cod. MT	Cod. NAKAMURA	N°Utensili N°Tools N°Werkzeuge	Reversibile lato mandrino/contromandrino Reversible sub/main spindle side Umkehrbare Spindel-seite/ Gegenspindel-seite	Misure Dimensions Masse	B	H
NKM0382000	G314 16	4	X	mm	20	20
NKM0381905	G314 17	4	X	inch	3/4"	3/4"

NAKAMURA - TOME

MOD: Super Mill WT150/WT15011/WY250/SC200L - SUPER NTY3 JUMBO

PORTAUTENSILE RADIALE MULTIPLO QD=20mm / QD=3/4"

Radial multiple static tool QD=20mm / QD=3/4"

Radial Mehrfach-Halter QD=20mm / QD=3/4"

Subject to change without notice.

M.T. srl

Via Casino Albini 480

Tel. 0541/956034-957884

Fax 0541/956341

47842 S. GIOVANNI IN M. (RN)

e-mail: mtma@mtmarchetti.com

http://www.mtmarchetti.com

PRODUZIONE MODULI ROTANTI



PAGINA NKM470-4-00

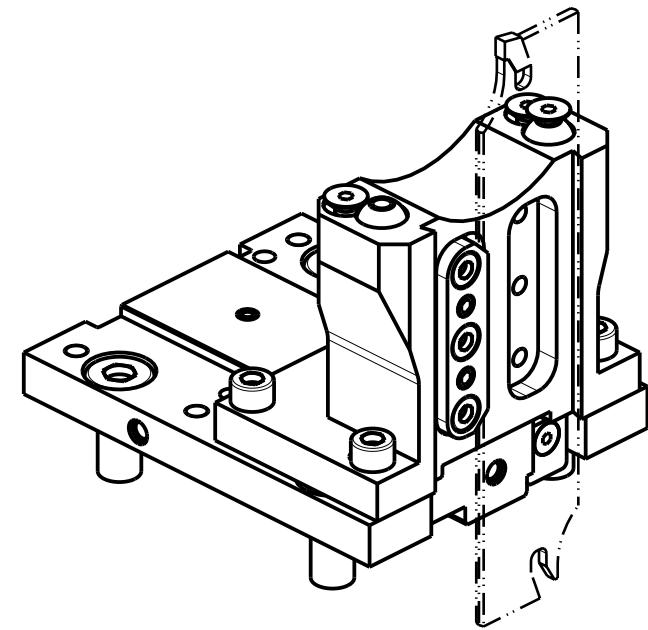
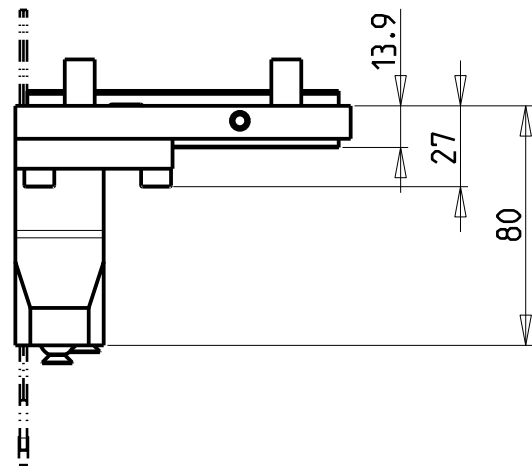
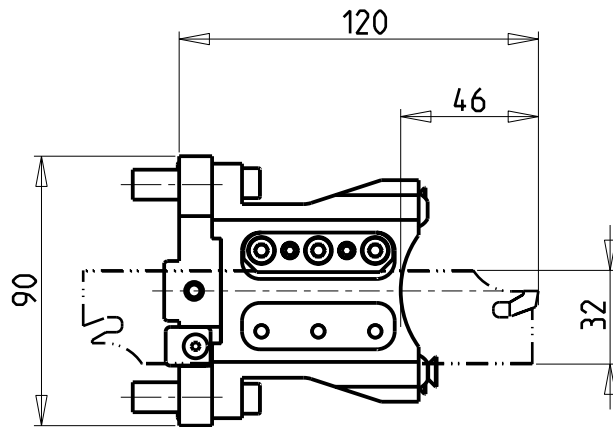
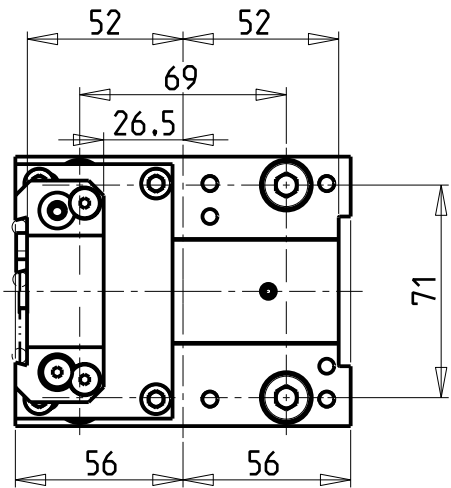

POSSIBILITA' DI LAVORO M3/M4
 OPTION OF M3/M4 WORKING
 ARBEITSMOGLICHKEIT M3/M4

DOTAZIONI - SUPPLIED WITH - AUSSTATTUNG

- N°1 - LAMA - BLADE - KLINGE ISCAR H=32 Sp. 3/4mm (KENNAMETAL OPTIONAL)
- N°10 - INSERTI - INSERTS - EINLAGEN
- N°1 - CHIAVE A T PER MONTAGGIO INSERTI
 - T-WRENCH FOR INSERT SET UP
 - T-SCHLUESSEL FUER EINSATZSTUECK-MONTAGE

Cod. MT	N°Utensili N°Tools N°Werkzeuge	Reversibile lato mandrino/contromandrino Reversible sub/main spindle side Umkehrbare Spindel-seite/ Gegenspindel-seite	Lubr.esterna Ext. coolant Aussehenkuehlung
NKM1150132	1	X	X

NAKAMURA-TOME

MOD: Super Mill WT150/WT15011/WY250/SC200L - SUPER NTY3 JUMBO

PORTAUTENSILE RADIALE PER LAMA

Radial blade holder

Radial Abstechhalter

Subject to change without notice.

M.T. srl

Via Casino Albini 480
 Tel. 0541/956034-957884
 Fax 0541/956341
 47842 S. GIOVANNI IN M. (RN)
 e-mail: mtma@mtmarchetti.com
 http://www.mtmarchetti.com

PRODUZIONE MODULI ROTANTI



PAGINA NKM520-4-01

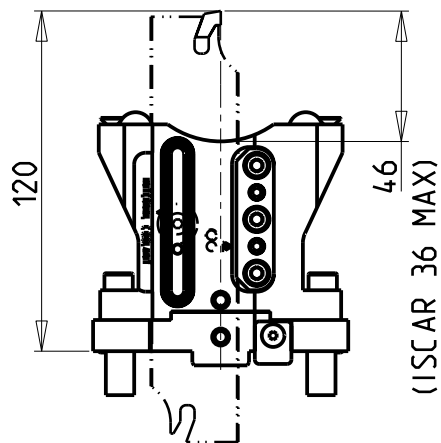
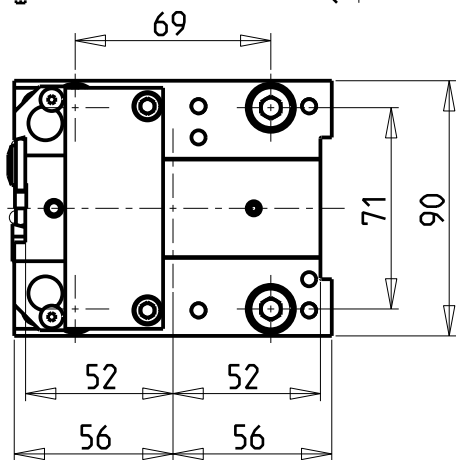
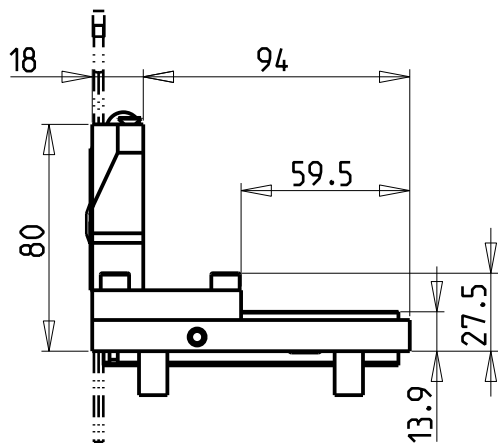

versione dx
right version
version rechts

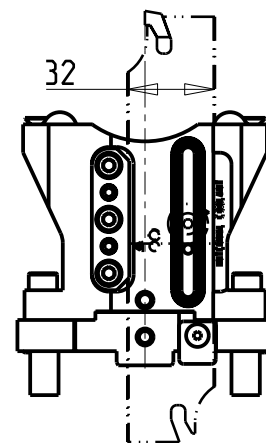

versione sx
left version
version links

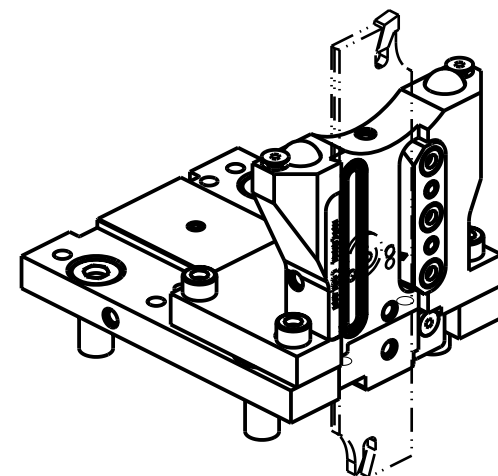

**KIT LAME NON INCLUSI (OPZIONALI)
BLADES NOT SUPPLIED WITH (OPTIONAL)
KLINGEN NICHT INBEGRIFFEN (OPTIONAL)**

- LAMA-BLADE-KLINGE SANDVIK H=32 sp.3 cod. QD_NN2G60C25A
+INSERTI-INSERTS-EINLAGEN cod. QD_NG_0300_0002_CM_1145 (10 pz.)
- LAMA-BLADE-KLINGE SANDVIK H=32 sp.4 cod. QD_NN2H60C25A
+INSERTI-INSERTS-EINLAGEN cod. QD_NH_0400_0002_CM_1145 (10 pz.)
- LAMA-BLADE-KLINGE ISCAR H=32 sp.3 cod. SGFH_32K_3
+INSERTI-INSERTS-EINLAGEN cod. 6011365 (10pz.)
- LAMA-BLADE-KLINGE ISCAR H=32 sp.4 cod. SGFH_32K_4
+INSERTI-INSERTS-EINLAGEN cod. 6011366 (10pz.)
- LAMA-BLADE-KLINGE WALTER H=32 sp.3 cod. G2042.32N-3T45SX-P
+INSERTI-INSERTS-EINLAGEN cod. SX-3E300N02-CE4 WSM33S (10pz.) + CHIAVE-KEY cod. FS1494
- LAMA-BLADE-KLINGE WALTER H=32 sp.4 cod. G2042.32N-4T50SX-P
+INSERTI-INSERTS-EINLAGEN cod. SX-4E400N02-CE4 WSM33S (10pz.) + CHIAVE-KEY cod. FS1494

Cod. MT		N°Utensili N°Tools N°Werkzeuge	Reversibile lato mandrino/contromandrino Reversible sub/main spindle side Umkehrbare Spindel-seite/ Gegenspindel-seite	Lubr.esterna Ext. coolant Aussenkuehlung	Lubr.interna Coolant through Innenkuehlung
versione dx right version version rechts	versione sx left version version links				
NKM1160132R	NKM1160132L	1	X	X	P=70bar

NAKAMURA-TOME

MOD: Super Mill WT150/WT15011/WY250/SC200L - SUPER NTY3 JUMBO

PORTAUTENSILE RADIALE PER LAMA CON LUBRIFICAZIONE INTERNA

Radial blade holder with internal coolant

Radial Abstechhalter mit Innenkuehlung

Subject to change without notice.

M.T. srl

Via Casino Albini 480
Tel. 0541/956034-957884
Fax 0541/956341
47842 S. GIOVANNI IN M. (RN)
e-mail: mtma@mtmarchetti.com
http://www.mtmarchetti.com

PRODUZIONE MODULI ROTANTI



PAGINA NKM520-4-05

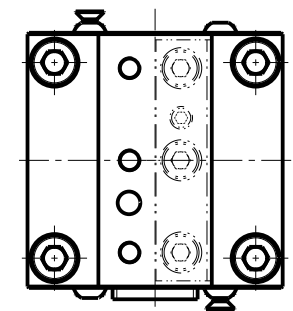
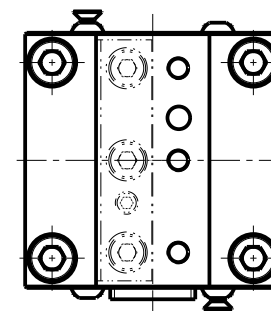
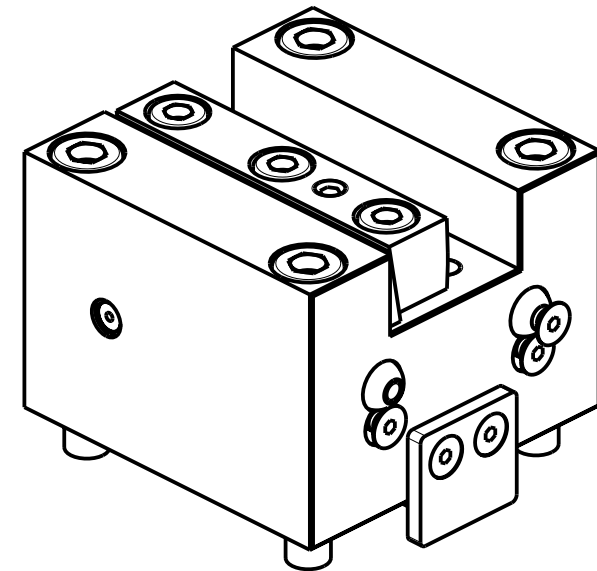
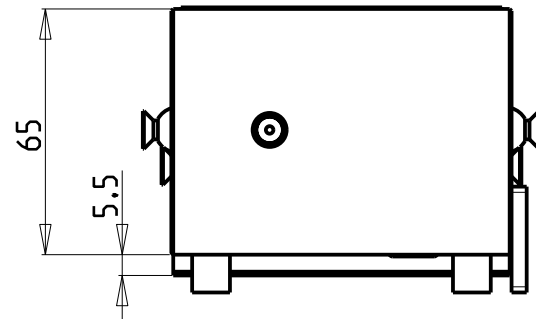
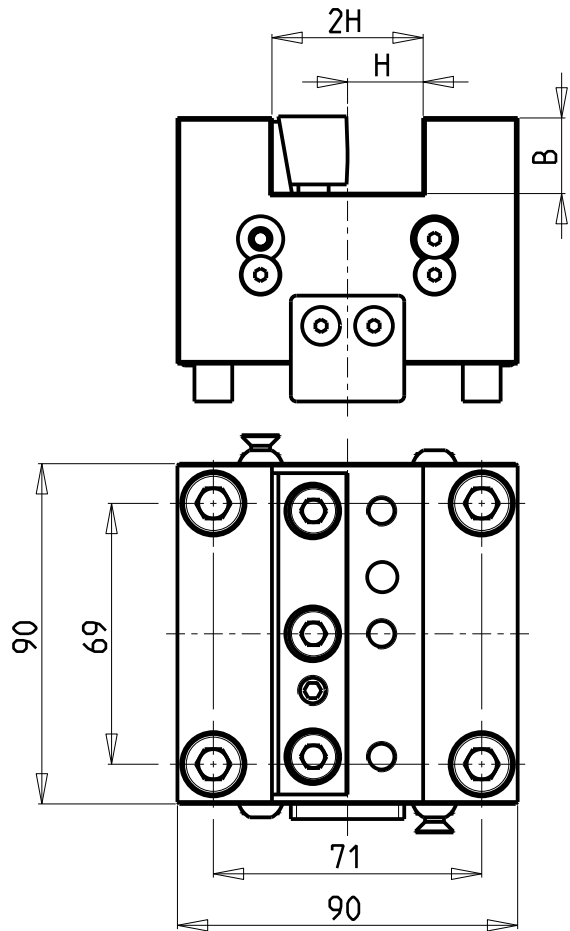

Cod. MT	Cod. NAKAMURA	N°utensili N°Tools N°Werkzeuge	Reversibile lato mandrino/contromandrino Reversible sub/main spindle side Umkehrbare Spindel-seite/ Gegenspindel-seite	Misure Dimensions Masse	B	H
NKM0432000	G31514	1	X	mm	20	20
NKM0432500	G31414	1	X	mm	25	25

NAKAMURA-TOME

MOD: Super Mill WT150/WT15011/WY250/SC200L - SUPER NTY3 JUMBO

PORTAUTENSILE ASSIALE SINGOLO QD=20mm / QD=25mm

Axial single static tool QD=20mm / QD=25mm

Axial Single-Werkzeughalter QD=20mm / QD=25mm

Subject to change without notice.

M.T. srl

Via Casino Albini 480
Tel. 0541/956034-957884
Fax 0541/956341
47842 S. GIOVANNI IN M. (RN)
e-mail: mtma@mtmarchetti.com
http://www.mtmarchetti.com

PRODUZIONE MODULI ROTANTI



PAGINA NKM552-4-00

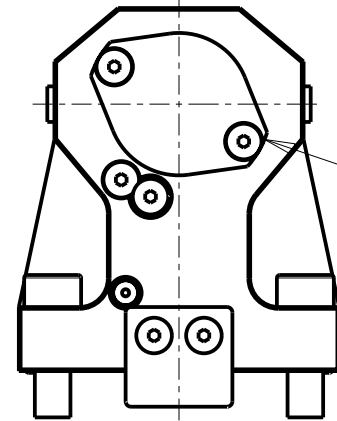
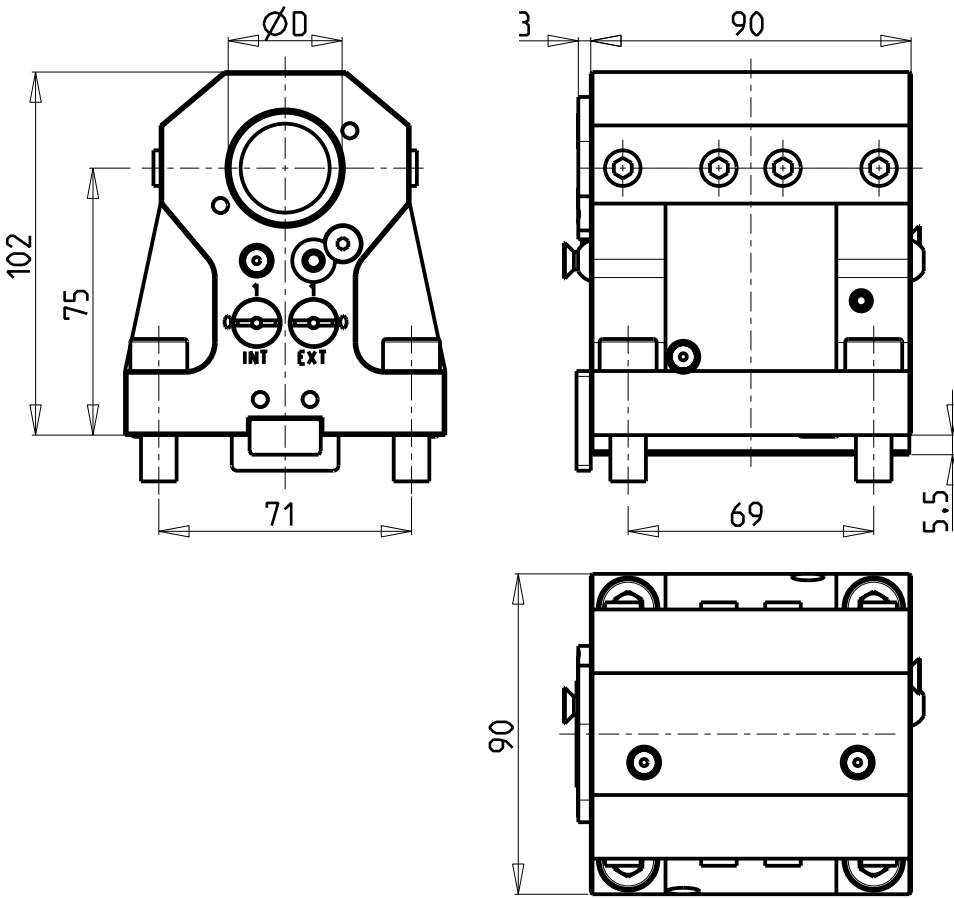

KIT ADDUZIONE INTERNA (OPZIONALE)
 KIT FOR INTERNAL COOLANT (OPTIONAL)
 KIT FUER INTERNE KUEHLMITTELZUFUHR (OPTIONAL)
 Ø32-Ø1 1/4" cod. KIT1000001
 Ø40 cod. KIT1000018
 Ø1 1/2" cod. KIT1000021

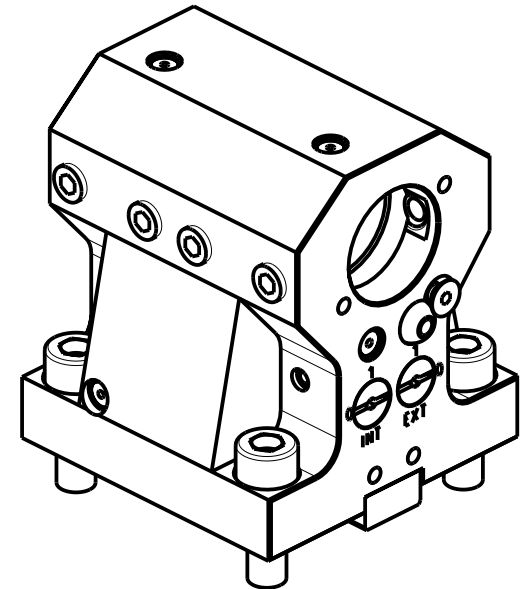

PER BOCCOLE DI RIDUZIONE VEDI PAG. TBL150-1-00
 FOR REDUCING BUSHINGS SEE PAGE TBL150-1-00
 FÜR REDUZIERBUCHSE SIEHE SEITE TBL150-1-00

Cod. MT	N°Utensili N°Tools N°Werkzeuge	Reversibile lato mandrino/contromandrino Reversible sub/main spindle side Umkehrbare Spindel-seite/ Gegenspindel-seite	Lubrificazione int. opzionale Coolant through optional Innenkuehlung Optional	Lubrificazione est. Ext. coolant Aussenkuehlung	Ø
NKM0303200	1	X	X	X	32
NKM0304000	1	X	X	X	40
NKM0303810	1	X	X	X	1 1/2"

NAKAMURA-TOME

MOD: Super Mill WT150/WT15011/WY250/SC200L - SUPER NTY3 JUMBO
 PORTAUTENSILE ASSIALE PER BARENO Ø32mm / Ø40mm / Ø1 1/2" H=75mm
 Axial single boring bar holder Ø32mm / Ø40mm / Ø1 1/2" H=75mm
 Axial Bohrhälter Ø32mm / Ø40mm / Ø1 1/2" H=75mm

Subject to change without notice.

M.T. srl
 Via Casino Albini 480
 Tel. 0541/956034-957884
 Fax 0541/956341
 47842 S. GIOVANNI IN M. (RN)
 e-mail: mtma@mtmarchetti.com
 http://www.mtmarchetti.com

PRODUZIONE MODULI ROTANTI



PAGINA NKM650-4-10

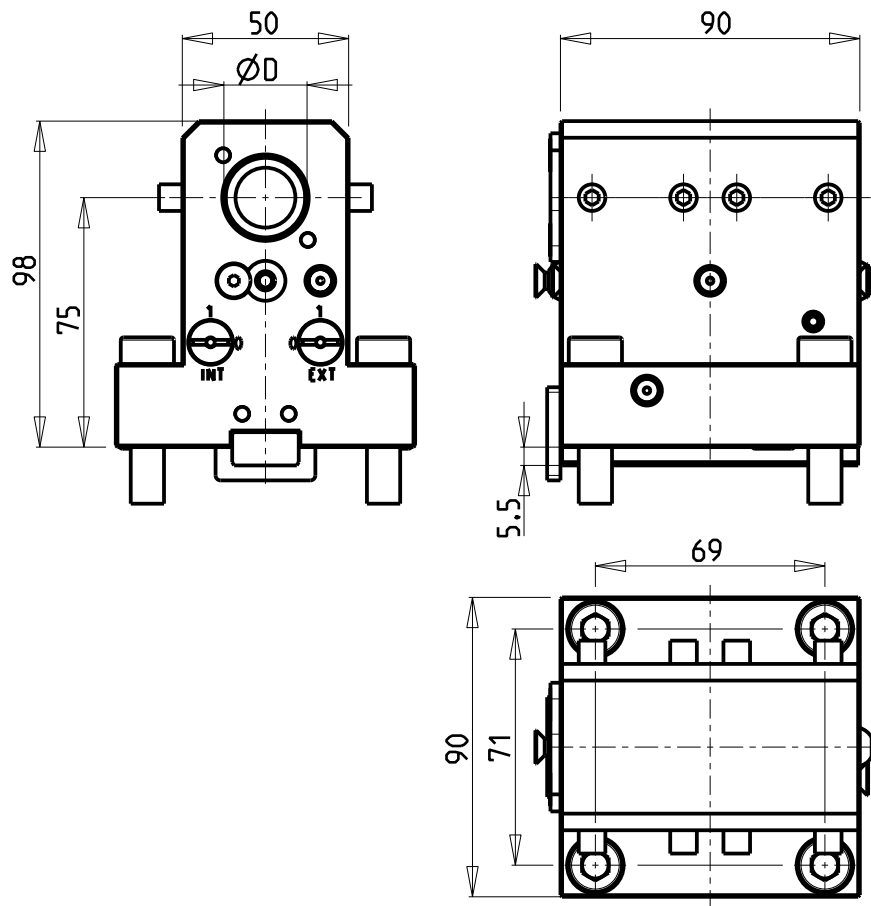

KIT ADDUZIONE INTERNA (OPZIONALE)
 KIT FOR INTERNAL COOLANT (OPTIONAL)
 KIT FUER INTERNE KUEHLMITTELZUFUHR (OPTIONAL)
 Ø25-Ø1" cod. KIT1000006

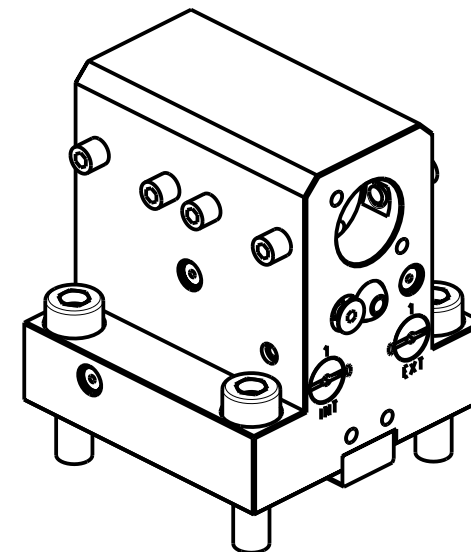
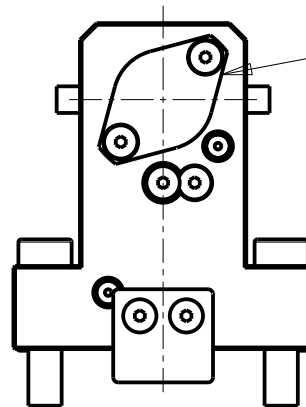

PER BOCCOLE DI RIDUZIONE VEDI PAG. TBL150-1-00
 FOR REDUCING BUSHINGS SEE PAGE TBL150-1-00
 FÜR REDUZIERBUCHSE SIEHE SEITE TBL150-1-00

Cod. MT	N°Utensili N°Tools N°Werkzeuge	Reversibile lato mandrino/contromandrino Reversible sub/main spindle side Umkehrbare Spindel-seite/ Gegenspindel-seite	Lubrificazione int. opzionale Coolant through optional Innenkuehlung Optional	Lubrificazione est. Ext. coolant Aussenkuehlung	Misure Dimensions Masse	D
NKM0302500	1	X	X	X	mm	25
NKM0302540	1	X	X	X	inch	1"

NAKAMURA-TOME

MOD: Super Mill WT150/WT15011/WY250/SC200L - SUPER NTY3 JUMBO

PORTAUTENSILE ASSIALE PER BARENO Ø25mm / Ø1" H=75mm

Axial single boring bar holder Ø25mm / Ø1" H=75mm

Axial Bohrhälter Ø25mm / Ø1" H=75mm

Subject to change without notice.

M.T. srl

Via Casino Albini 480
 Tel. 0541/956034-957884
 Fax 0541/956341
 47842 S. GIOVANNI IN M. (RN)
 e-mail: mtma@mtmarchetti.com
 http://www.mtmarchetti.com

PRODUZIONE MODULI ROTANTI



PAGINA NKM670-4-10

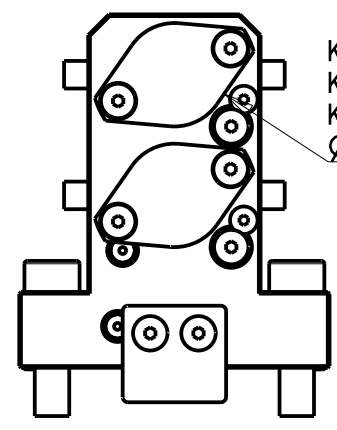
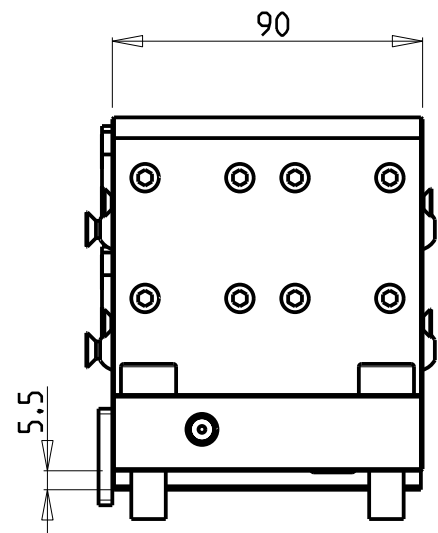
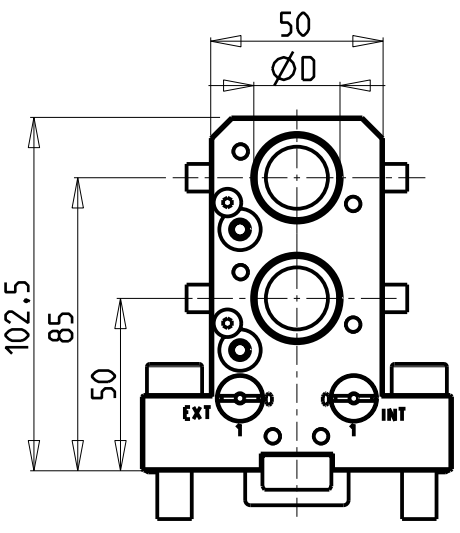

KIT ADDUZIONE INTERNA (OPZIONALE)
 KIT FOR INTERNAL COOLANT (OPTIONAL)
 KIT FUER INTERNE KUEHLMITTELZUFUHR (OPTIONAL)
 Ø25-Ø1" cod. KIT1000006

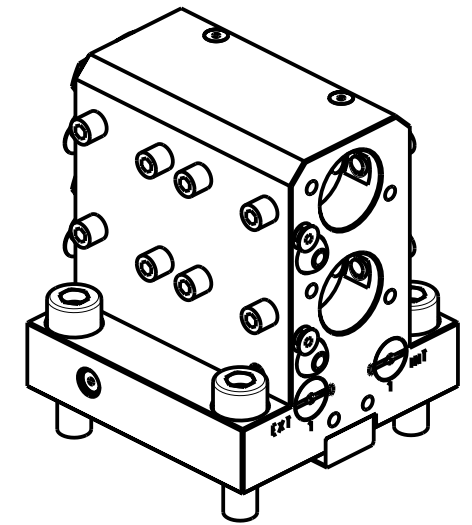
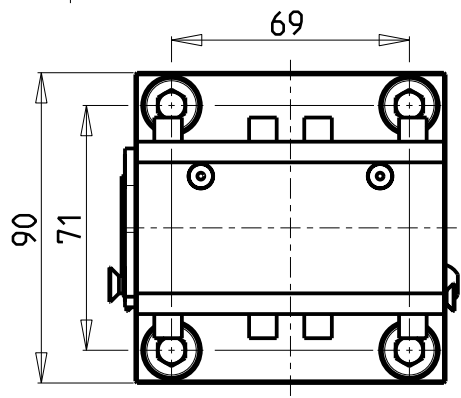

Cod. MT	N°Utensili N°Tools N°Werkzeuge	Reversibile lato mandrino/contromandrino Reversible sub/main spindle side Umkehrbare Spindel-seite/ Gegenspindel-seite	Lubrificazione int. opzionale Coolant through optional Innenkuehlung Optional	Lubrificazione est. Ext. coolant Aussenkuehlung	Misure Dimensions Masse	D
NKM0442500	2	X	X	X	mm	25
NKM0442540	2	X	X	X	inch	1"

PER BOCCOLE DI RIDUZIONE VEDI PAG. TBL150-1-00
 FOR REDUCING BUSHINGS SEE PAGE TBL150-1-00
 FÜR REDUZIERBUCHSE SIEHE SEITE TBL150-1-00

NAKAMURA-TOME

MOD: Super Mill WT150/WT15011/WY250/SC200L - SUPER NTY3 JUMBO

PORTAUTENSILE ASSIALE PER BARENO 2 POSIZIONI Ø25mm / Ø1"

Axial double boring bar holder Ø25mm / Ø1"

Axial Bohrrhalter 2 Positionen Ø25mm / Ø1"

Subject to change without notice.

M.T. srl
 Via Casino Albini 480
 Tel. 0541/956034-957884
 Fax 0541/956341
 47842 S. GIOVANNI IN M. (RN)
 e-mail: mtma@mtmarchetti.com
 http://www.mtmarchetti.com

PRODUZIONE MODULI ROTANTI



PAGINA NKM864-4-00

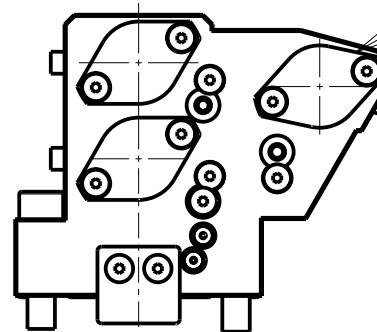
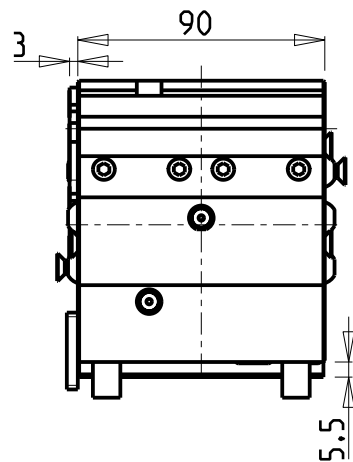
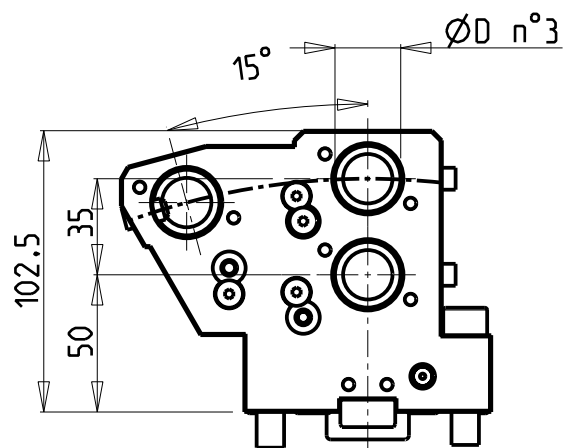

KIT ADDUZIONE INTERNA (OPZIONALE)
 KIT FOR INTERNAL COOLANT (OPTIONAL)
 KIT FUER INTERNE KUEHLMITTELZUFUHR (OPTIONAL)
 Ø25-Ø1" cod. KIT1000006

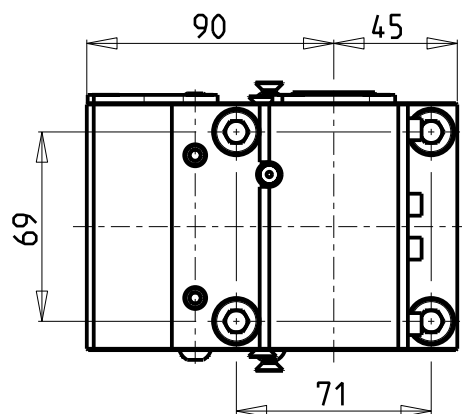
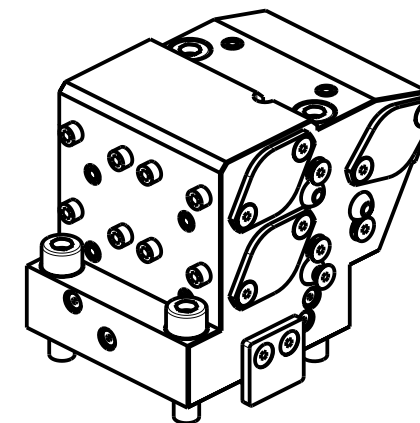

PER BOCCOLE DI RIDUZIONE VEDI PAG. TBL150-1-00
 FOR REDUCING BUSHINGS SEE PAGE TBL150-1-00
 FUR REDUZIERBUCHSE SIEHE SEITE TBL150-1-00

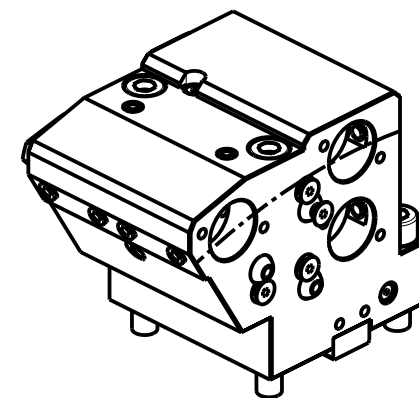

Cod. MT	N°Utensili N°Tools N°Werkzeuge	Reversibile lato mandrino/contromandrino Reversible sub/main spindle side Umkehrbare Spindel-seite/ Gegenspindel-seite	Lubrificazione int. opzionale Coolant through optional Innenkuehlung Optional	Lubrificazione est. Ext. coolant Aussenkuehlung	Misure Dimensions Masse	ØD
NKM0392500	3	X	X	X	mm	25
NKM0392540	3	X	X	X	inch	1"

NAKAMURA-TOME

MOD: Super Mill WT150/WT15011/WY250/SC200L - SUPER NTY3 JUMBO

PORTAUTENSILE ASSIALE PER BARENO 3 POSIZIONI Ø25mm / Ø1"

Axial 3 position boring bar holder Ø25mm / Ø1"

Axial Bohrhälter 3 Positionen Ø25mm / Ø1"

Subject to change without notice.

M.T. srl

Via Casino Albini 480
 Tel. 0541/956034-957884
 Fax 0541/956341
 47842 S. GIOVANNI IN M. (RN)
 e-mail: mtma@mtmarchetti.com
 http://www.mtmarchetti.com

PRODUZIONE MODULI ROTANTI



PAGINA NKM884-4-00

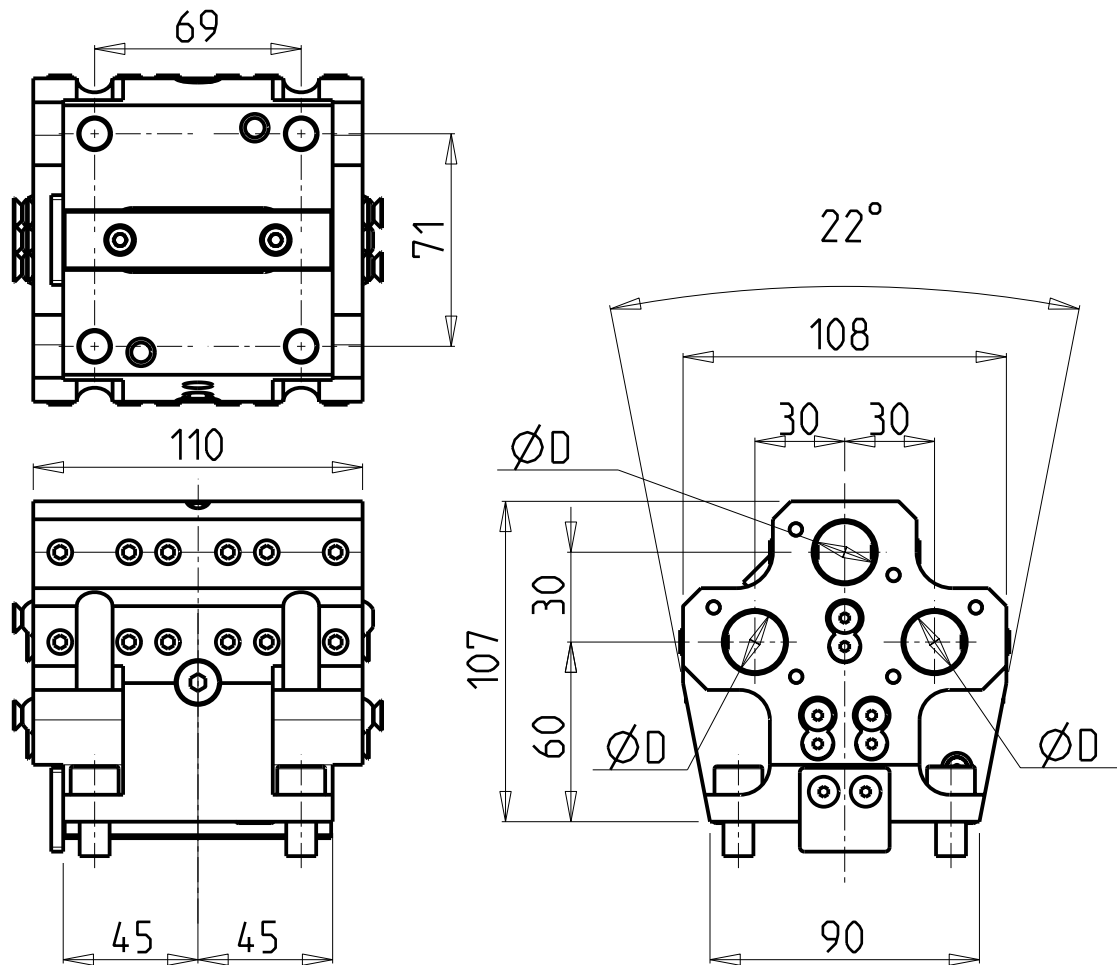

ATTENZIONE - ATTENTION - ACHTUNG

- VERIFICARE LE MISURE DI INGOMBRO PER POSSIBILE INTERFERENZA SU ALCUNI MODELLI DI MACCHINE
- Please check the overall sizes for possible interferences on some machine models
- Bitte überprüfen sie das ausmass um mögliche interferenzen auf einigen maschinen modellen zu vermeiden

KIT ADDUZIONE INTERNA (OPZIONALE)
 KIT FOR INTERNAL COOLANT (OPTIONAL)
 KIT FUER INTERNE KUEHLMITTELZUFUHR (OPTIONAL)
 Ø20mm cod. KIT100005

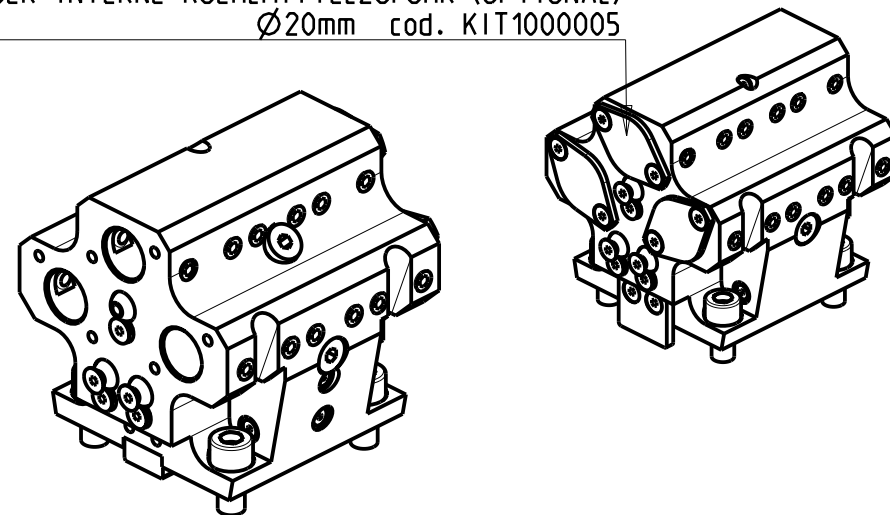

PER BOCCOLE DI RIDUZIONE VEDI PAG. TBL150-1-00
 FOR REDUCING BUSHINGS SEE PAGE TBL150-1-00
 FUER REDUZIERBUCHSE SIEHE SEITE TBL150-1-00

Cod. MT	N°Utensili N°Tools N°Werkzeuge	Reversibile lato mandrino/contromandrino Reversible sub/main spindle side Umkehrbare Spindel-seite/ Gegenspindel-seite	Lubrificazione int. opzionale Coolant through optional Innenkuehlung Optional	Lubrificazione est. Ext. coolant Aussenkuehlung	Misure Dimensions Masse	D
NKM1132000	3+3	X	X	X	mm	20

NAKAMURA-TOME

MOD: Super Mill WT150/WT15011/WY250/SC200L - SUPER NTY3 JUMBO

PORTAUTENSILE ASSIALE PER BARENO 3+3 POSIZIONI Ø20mm

Axial 3+3 position boring bar holder Ø20mm

Axial Bohrhälter 3+3 Positionen Ø20mm

Subject to change without notice.

M.T. srl

Via Casino Albini 480
 Tel. 0541/956034-957884
 Fax 0541/956341
 47842 S. GIOVANNI IN M. (RN)
 e-mail: mtma@mtmarchetti.com
 http://www.mtmarchetti.com

PRODUZIONE MODULI ROTANTI



PAGINA NKM914-4-00

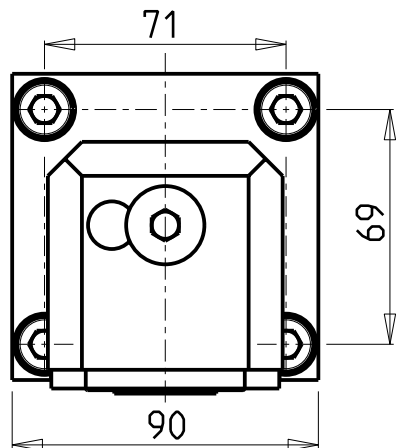
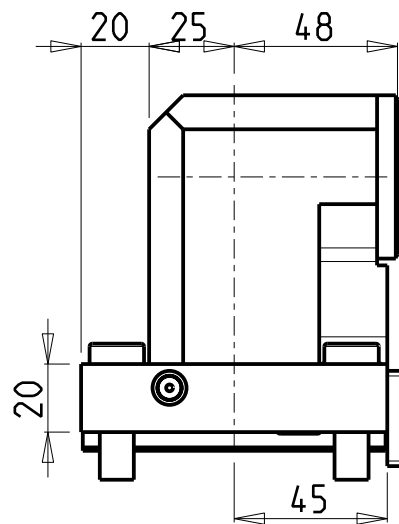
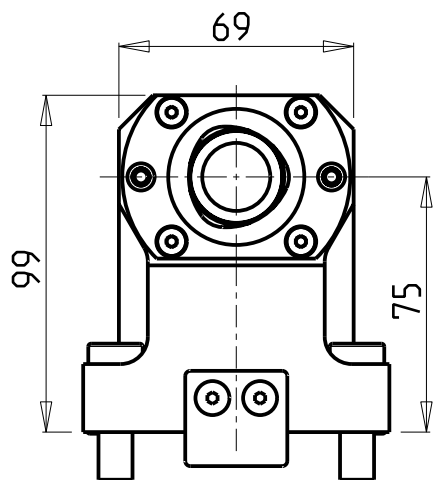

VERSIONE DESTRA (RC)
RIGHT VERSION (RC)
RECHTE-VERSION (RC)



VERSIONE SINISTRA (LC)
LEFT VERSION (LC)
LINKE-VERSION (LC)



PER ORDINARE LA VERSIONE SX
AGGIUNGERE "LC" AL CODICE IN TABELLA.
ES: MNL0464010 DIVENTA MNL0464010LC

TO ORDER LEFT VERSION
ADD A "LC" IN THE CODE-CHARTS.
EXAMPLE: MNL0464010 BECOMES MNL0464010LC

UM DIE LINKE-VERSION ZU BESTELLEN, BEI DER
ARTIKELBEZEICHNUNG "LC" HINZUFUEGEN.
BEISPIEL: MNL0464010 WIRD DANN MNL0464010LC

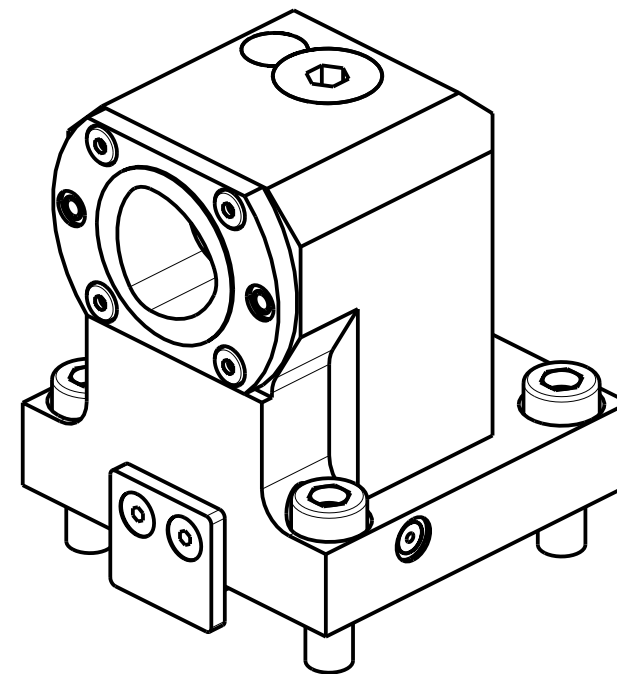

Cod. MT	N°Utensili N°Tools N°Werkzeuge	Lubrificazione int. Coolant through Innenkuehlung	Reversibile lato mandrino/contromandrino Reversible sub/main spindle side Umkehrbare Spindel-seite/ Gegenspindel-seite	TAGLIA Size Masse
NKM0874010	1	X	X	C4

NAKAMURA-TOME

MOD: Super Mill WT150/WT15011/WY250/SC200L - SUPER NTY3 JUMBO

PORTAUTENSILE ASSIALE SINGOLO MT CAPTO

Axial single static tool MT CAPTO

Axial Single-Werkzeughalter MT CAPTO

Subject to change without notice.

M.T. srl

Via Casino Albini 480
Tel. 0541/956034-957884
Fax 0541/956341
47842 S. GIOVANNI IN M. (RN)
e-mail: mtma@mtmarchetti.com
http://www.mtmarchetti.com

PRODUZIONE MODULI ROTANTI



PAGINA NKM550-D-40

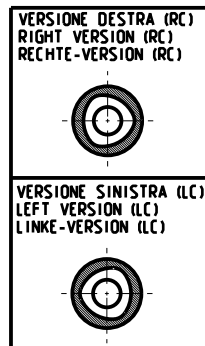
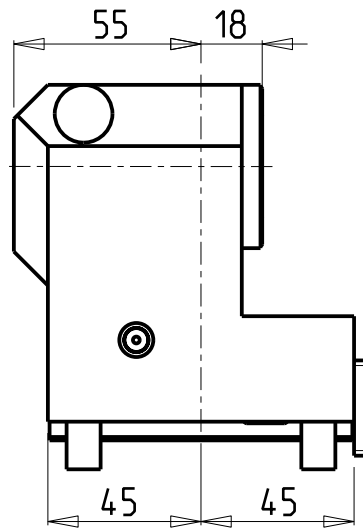
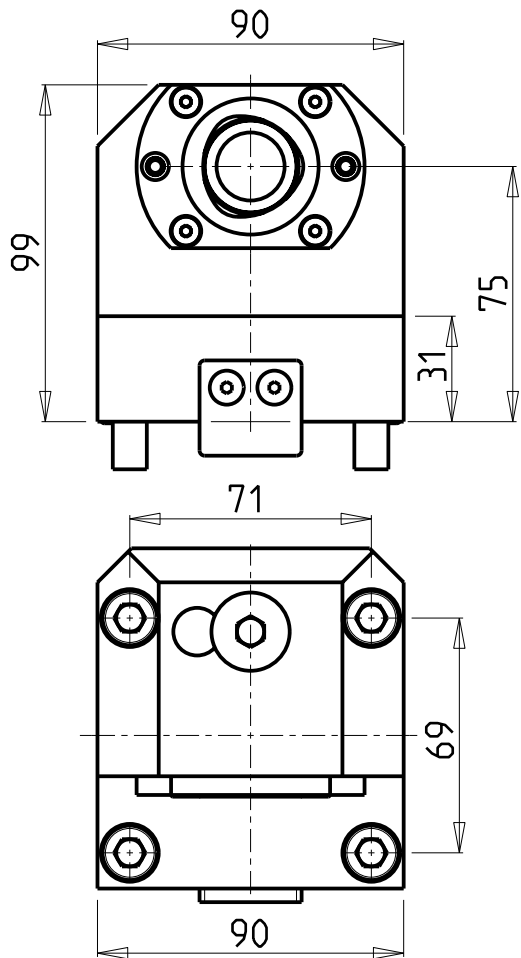

**PER ORDINARE LA VERSIONE SX
AGGIUNGERE "LC" AL CODICE IN TABELLA.
ES: MNL0464010 DIVENTA MNL0464010LC**

**TO ORDER LEFT VERSION
ADD A "LC" IN THE CODE-CHARTS.
EXAMPLE: MNL0464010 BECOMES MNL0464010LC**

**UM DIE LINKE-VERSION ZU BESTELLEN, BEI DER
ARTIKELBEZEICHNUNG "LC" HINZUFUEGEN.
BEISPIEL: MNL0464010 WIRD DANN MNL0464010LC**

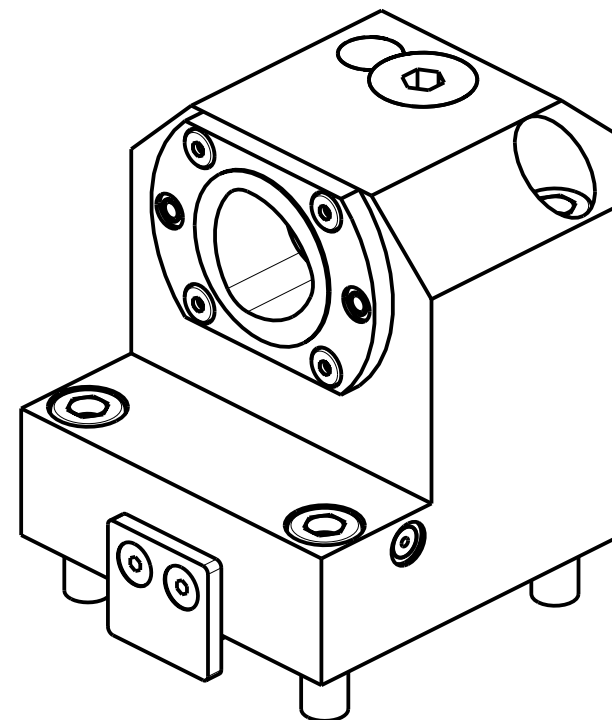

Cod. MT	N°Utensili N°Tools N°Werkzeuge	Lubrificazione int. Coolant through Innenkuehlung	Reversibile lato mandrino/contromandrino Reversible sub/main spindle side Umkehrbare Spindel-seite/ Gegenspindel-seite	TAGLIA Size Masse
NKM1064010	1	X	X	C4

NAKAMURA-TOME

MOD: Super Mill WT150/WT15011/WY250/SC200L - SUPER NTY3 JUMBO

PORTAUTENSILE ASSIALE SINGOLO ARRETRATO MT CAPTO

Axial rear-set boring single static tool MT CAPTO

Axial Single-Werkzeughalter zurueckversetzt MT CAPTO

Subject to change without notice.

M.T. srl

Via Casino Albini 480
Tel. 0541/956034-957884
Fax 0541/956341
47842 S. GIOVANNI IN M. (RN)
e-mail: mtma@mtmarchetti.com
http://www.mtmarchetti.com

PRODUZIONE MODULI ROTANTI



PAGINA NKM555-D-40

