

		PAGINA Page Seite
<b>MODULO MOTORIZZATO RADIALE</b> Radial driven tool Radial angetriebenes Werkzeug		MTR010.1.00
<b>MODULO MOTORIZZATO RADIALE MTSK</b> Radial MTSK driven tool Radial MTSK angetriebenes Werkzeug		MTR010.1.00.K
<b>MODULO MOTORIZZATO RADIALE 10000 RPM</b> Radial driven tool 10000 rpm Radial angetriebenes Werkzeug 10000 rpm		MTR010.1.01
<b>MODULO MOTORIZZATO RADIALE MTSK 10000 RPM</b> Radial MTSK driven tool 10000 rpm Radial MTSK angetriebenes Werkzeug 10000 rpm		MTR010.1.01.K
<b>MODULO MOTORIZZATO RADIALE ALTA PRESSIONE</b> Radial driven tool high pressure Radial angetriebenes Werkzeug hochdruck		MTR010.1.20
<b>MODULO MOTORIZZATO RADIALE MTSK ALTA PRESSIONE</b> Radial MTSK driven tool high pressure Radial MTSK angetriebenes Werkzeug hochdruck		MTR010.1.20.K
<b>MODULO MOTORIZZATO RADIALE 10000 RPM</b> Radial driven tool 10000 rpm Radial angetriebenes Werkzeug 10000 rpm		MTR010.1.21
<b>MODULO MOTORIZZATO RADIALE MTSK 10000 RPM</b> Radial MTSK driven tool 10000 rpm Radial MTSK angetriebenes Werkzeug 10000 rpm		MTR010.1.21.K
<b>MODULO MOTORIZZATO RADIALE MAGGIORATO</b> Radial reinforced driven tool Radial angetriebenes Werkzeug vergrößert		MTR020.1.00
<b>MODULO MOTORIZZATO RADIALE MAGGIORATO MTSK</b> Radial MTSK reinforced driven tool Radial MTSK angetriebenes Werkzeug vergrößert		MTR020.1.00.K
<b>MODULO MOTORIZZATO RADIALE RIDOTTO 1=2:1 DISASSATO IN Z 45mm</b> Radial geared-down 1=2:1 driven tool re-directed in Z by 45mm Radial angetriebenes Werkzeug untersetzt 1=2:1 achsversetzt in Z um 45mm		MTR030.1.20
<b>MODULO MOTORIZZATO RADIALE DISASSATO IN Z 45mm</b> Radial driven tool re-directed in Z by 45mm Radial angetriebenes Werkzeug achsversetzt in Z um 45mm		MTR033.1.10

		PAGINA Page Seite
<p><b>MODULO MOTOR. RADIALE MOLTIPLICATO 1:2 DISASSATO IN Z 45mm</b> Radial geared-up 1=1:2 driven tool re-directed in Z by 45mm Radial angetriebenes Werkzeug uebersetzt 1=1:2 achsversetzt in Z um 45mm</p>		MTR033.1.30
<p><b>MODULO MOTORIZZATO RADIALE MOLTIPLICATO 1:5</b> Radial geared-up 1=1:5 driven tool Radial angetriebenes Werkzeug uebersetzt 1=1:5</p>		MTR059.1.00
<p><b>MODULO MOTORIZZATO RADIALE 2 USCITE IN Y</b> Radial single side twin head driven tool in Y Radial angetriebenes Werkzeug 2 Ausgaenge in Y</p>		MTR080.1.00
<p><b>MODULO MOTORIZZATO RADIALE 2 USCITE IN Z</b> Radial single side twin head driven tool in Z Radial angetriebenes Werkzeug 2 Ausgaenge in Z</p>		MTR090.1.00
<p><b>MODULO MOTORIZZATO RADIALE 6 USCITE</b> Radial 6 head driven tool Radial angetriebenes Werkzeug 6 Ausgaenge</p>		MTR110.1.00
<p><b>MODULO MOTORIZZATO RADIALE ROVESCiato DISASSATO IN Z</b> Radial inverted driven tool re-directed in Z Radial angetriebenes Werkzeug ungekehrt achsversetzt in Z</p>		MTR120.1.30
<p><b>MODULO MOTORIZZATO RADIALE DISASSATO 50mm ORIENTABILE ±25°</b> Radial ±25° adjustable angle driven tool re-directed by 50mm Radial angetriebenes Werkzeug schwenkbar ±25° achsversetzt um 50mm</p>		MTR135.1.00
<p><b>MODULO MOTORIZZATO ASSIALE</b> Axial driven tool Axial angetriebenes Werkzeug</p>		MTR150.1.10
<p><b>MODULO MOTORIZZATO ASSIALE MTSK</b> Axial MTSK driven tool Axial MTSK angetriebenes Werkzeug</p>		MTR150.1.10.K
<p><b>MODULO MOTORIZZATO ASSIALE 10000 RPM</b> Axial driven tool 10000 rpm Axial angetriebenes Werkzeug 10000 rpm</p>		MTR150.1.11
<p><b>MODULO MOTORIZZATO ASSIALE MTSK 10000 RPM</b> Axial MTSK driven tool 10000 rpm Axial MTSK angetriebenes Werkzeug 10000 rpm</p>		MTR150.1.11.K
<p><b>MODULO MOTORIZZATO ASSIALE</b> Axial driven tool Axial angetriebenes Werkzeug</p>		MTR170.1.10

		PAGINA Page Seite
<p><b>MODULO MOTORIZZATO ASSIALE MTSK</b> Axial MTSK driven tool Axial MTSK angetriebenes Werkzeug</p>		MTR170.1.10.K
<p><b>MODULO MOTORIZZATO ASSIALE ARRETRATO</b> Axial rear-set driven tool Axial angetriebenes Werkzeug zurueckversetzt</p>		MTR180.1.10
<p><b>MODULO MOTORIZZATO ASSIALE RIDOTTO l=2:1</b> Axial geared-down l=2:1 driven tool Axial angetriebenes Werkzeug untersetzt l=2:1</p>		MTR190.1.10
<p><b>MODULO MOTORIZZATO ASSIALE MOLTIPLICATO l=1:2</b> Axial geared-up l=1:2 driven tool Axial angetriebenes Werkzeug uebersetzt l=1:2</p>		MTR200.1.10
<p><b>MODULO MOTORIZZ. ASSIALE MTSK PER POLIGONATURA INTERNA H=90mm</b> Axial MTSK driven tool for internal polygon-making H=90mm Axial MTSK angetriebenes Werkzeug fuer interne Facettierung H=90mm</p>		MTR231.1.10.K
<p><b>MODULO MOTOR. ASSIALE 2 USCITE IN Y PER POLIGON. INTERNA H=90mm</b> Axial Single side twin head driven tool in Y for internal polygon-making H=90mm Axial angetriebenes Werkzeug 2 Ausgaenge in Y fuer interne Facettierung H=90mm</p>		MTR233.1.10
<p><b>MODULO MOTORIZZATO ASSIALE BISPORGENTE</b> Axial opposite face twin driven tool Axial angetriebenes Werkzeug halb vorspringend</p>		MTR240.1.10
<p><b>MODULO MOTORIZZATO ASSIALE BISPORGENTE MTSK</b> Axial MTSK opposite face twin driven tool Axial MTSK angetriebenes Werkzeug halb vorspringend</p>		MTR240.1.10.K
<p><b>MODULO MOTORIZZATO ASSIALE BISPORGENTE 10000 RPM</b> Axial opposite face twin driven tool 10000 rpm Axial angetriebenes Werkzeug halb vorspringend 10000 rpm</p>		MTR240.1.11
<p><b>MODULO MOTORIZZATO ASSIALE BISPORGENTE MTSK 10000 RPM</b> Axial MTSK opposite face twin driven tool 10000 rpm Axial MTSK angetriebenes Werkzeug halb vorspringend 10000 rpm</p>		MTR240.1.11.K
<p><b>MODULO MOTORIZZATO ASSIALE BISPORGENTE RIDOTTO l=2:1</b> Axial geared-down l=2:1 opposite face twin driven tool Axial angetriebenes Werkzeug halb vorspringend untersetzt l=2:1</p>		MTR247.1.10
<p><b>MODULO MOTORIZZATO ASSIALE BISPORGENTE MOLTIPLICATO l=1:2</b> Axial geared-up l=1:2 opposite face twin driven tool Axial angetriebenes Werkzeug halb vorspringend uebersetzt l=1:2</p>		MTR250.1.10

		PAGINA Page Seite
<p><b>MODULO MOTORIZZATO ASSIALE 2 USCITE IN Y</b> Axial single side twin head driven tool in Y Axial angetriebenes Werkzeug 2 Ausgaenge in Y</p>		MTR260.1.10
<p><b>MODULO MOTORIZZATO ASSIALE 4/8 USCITE</b> Axial multiple 4/8 outlet driven tool Axial angetriebenes Mehrspindel-Werkzeug 4/8 Ausgaenge</p>		MTR270.1.00
<p><b>MODULO MOTORIZZATO ORIENTABILE 0-90°</b> 0-90° adjustable angle driven tool Angetriebenes Werkzeug schwenkbar 0-90°</p>		MTR330.1.00
<p><b>MODULO MOTORIZZATO ORIENTABILE ±90°</b> ±90° adjustable angle driven tool Angetriebenes Werkzeug schwenkbar ±90°</p>		MTR333.1.00
<p><b>MODULO MOTORIZZATO ORIENTABILE ±90° CON NONIO DIGITALE</b> ±90° adjustable angle driven tool with digital display Angetriebenes Werkzeug schwenkbar ±90° mit digital display</p>		MTR333.1.01
<p><b>MODULO MOTORIZZATO ORIENTABILE ±90°</b> ±90° adjustable angle driven tool Angetriebenes Werkzeug schwenkbar ±90°</p>		MTR335.1.00
<p><b>MODULO MOTORIZZATO ORIENTABILE ±90° CON NONIO DIGITALE</b> ±90° adjustable angle driven tool with digital display Angetriebenes Werkzeug schwenkbar ±90° mit digital display</p>		MTR335.1.01
<p><b>MODULO MOTORIZZATO ORIENTABILE ±90° MOLTIPLICATO 1-1:2</b> ±90° adjustable angle driven tool geared-up 1=1:2 Angetriebenes Werkzeug schwenkbar ±90° uebersetzt 1=1:2</p>		MTR336.1.00
<p><b>MOD. MOTOR. ORIENTABILE ±90° MOLTIPL 1-1:2 CON NONIO DIGITALE</b> ±90° adjustable angle driven tool geared-up 1=1:2 with digital display Angetriebenes Werkzeug schwenkbar ±90° uebersetzt 1=1:2 mit digital display</p>		MTR336.1.01
<p><b>MODULO MOTORIZZATO ORIENTABILE ±90°</b> ±90° adjustable angle driven tool Angetriebenes Werkzeug schwenkbar ±90°</p>		MTR339.1.00
<p><b>MODULO MOTORIZZATO PORTACREATORE</b> Driven gear hobber Angetriebenes Zahnradwaelzfraes-Werkzeug</p>		MTR340.1.00
<p><b>MODULO MOTORIZZATO PORTACREATORE MAGGIORATO</b> Reinforced gear hobber Angetriebenes Zahnradwaelzfraes-Werkzeug vergroessert</p>		MTR340.1.60

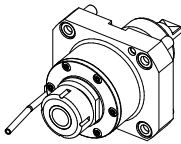
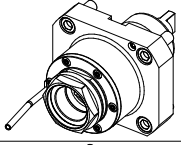
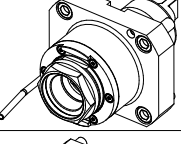
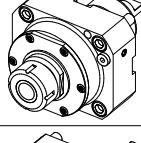
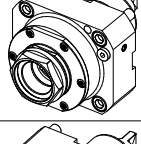
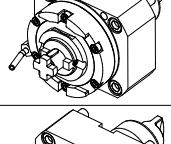
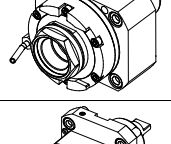
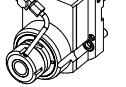
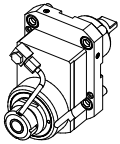
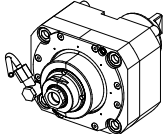
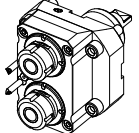
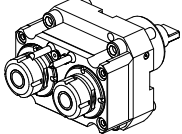
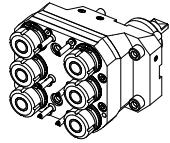
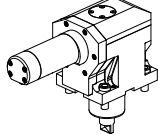
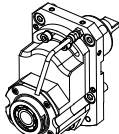
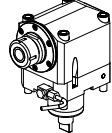
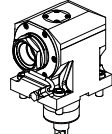
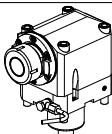
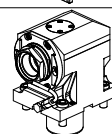
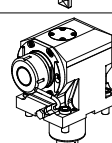
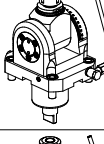

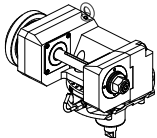
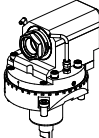
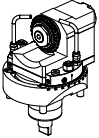
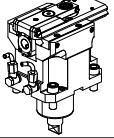
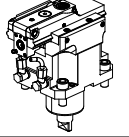
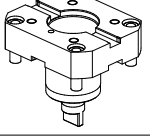
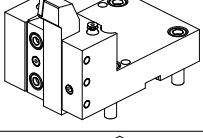
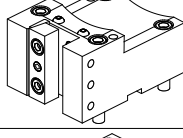
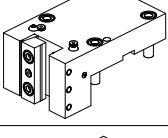
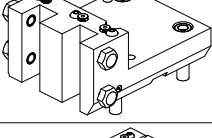
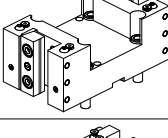
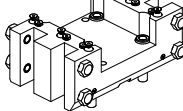
		PAGINA Page Seite
<b>MODULO MOTORIZZATO PORTACREATORE (TAGLIA GRANDE)</b> Driven gear hobber (big size) Angetriebenes Zahnradwaelzfraes-Werkzeug (grosse version)		MTR340.1.80
<b>MODULO MOTORIZZATO ASSIALE MTSK PER POWER SKIVING H=106mm</b> Axial MTSK driven tool for Power Skiving H=106mm Axial MTSK angetriebenes Werkzeug fuer Power Skiving H=106mm		MTR350.1.00.K
<b>MODULO MOTORIZZATO PER VITI SENZA FINE</b> Driven tool for worm screws Angetriebenes werkzeug fuer schrauben ohne ende		MTR359.1.00
<b>MODULO MOTORIZZATO STOZZATORE CORSA 50mm H=94mm</b> Slotting driven tool 50mm stroke H=94mm Keilnutenstossmaschine 50mm Hub H=94mm		MTR360.1.00
<b>MODULO MOTORIZZATO STOZZATORE CORSA 25mm H=94mm</b> Slotting driven tool 25mm stroke H=94mm Keilnutenstossmaschine 25mm Hub H=94mm		MTR360.1.01
<b>INTERFACCIA PER MODULI BIGLIA</b> Biglia tooling adapter cartridge Adapter-Patrone fuer Biglia Werkzeuge		MTR380.1.00
<b>PORTAUTENSILE RADIALE SINGOLO QD=25mm / QD=1" / QD=20mm / QD=3/4"</b> Radial single static tool QD=25mm / QD=1" / QD=20mm / QD=3/4" Radial Single-Werkzeughalter QD=25mm / QD=1" / QD=20mm / QD=3/4"		MTR423.1.00
<b>PORTAUTENSILE RADIALE SINGOLO QD=25mm / QD=20mm</b> Radial single static tool QD=25mm / QD=20mm Radial Single-Werkzeughalter QD=25mm / QD=20mm		MTR424.1.00
<b>PORTAUT. RADIALE SINGOLO ARRETR. QD=25mm / QD=1" / QD=20mm / QD=3/4"</b> Radial rear-set single static tool QD=25mm / QD=1" / QD=20mm / QD=3/4" Radial Single-Werkzeughalter zurueckver. QD=25mm / QD=1" / QD=20mm / QD=3/4"		MTR433.1.00
<b>PORTAUT. RADIALE SOVRAPPOSTO QD=25mm / QD=1" / QD=20mm / QD=3/4"</b> Radial single side twin static tool QD=25mm / QD=1" / QD=20mm / QD=3/4" Radial Werkzeughalter ueberlagert QD=25mm / QD=1" / QD=20mm / QD=3/4"		MTR442.1.00
<b>PORTAUTENSILE RADIALE DOPPIO QD=25mm / QD=1" / QD=20mm / QD=3/4"</b> Radial double static tool QD=25mm / QD=1" / QD=20mm / QD=3/4" Radial Doppel-Werkzeughalter QD=25mm / QD=1" / QD=20mm / QD=3/4"		MTR453.1.00
<b>PORTAUT. RADIALE DOPPIO SOVRAPP. QD=25mm / QD=1" / QD=20mm / QD=3/4"</b> Radial double side twin static tool QD=25mm / QD=1" / QD=20mm / QD=3/4" Radial Doppel-Werkzeughalter ueberlagert QD=25mm / QD=1" / QD=20mm / QD=3/4"		MTR463.1.00

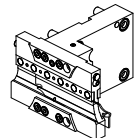
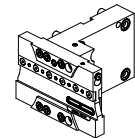
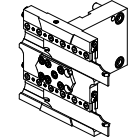
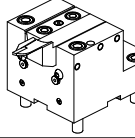
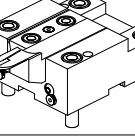
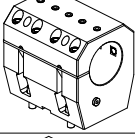
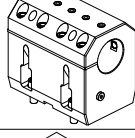
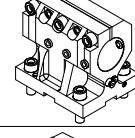
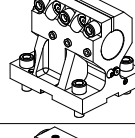
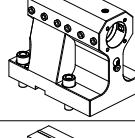
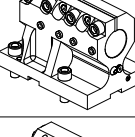
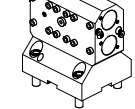
		PAGINA Page Seite
<b>PORTAUTENSILE PER LAMA DOPPIO</b> Radial double blade holder Radial Doppel-Abstechhalter		MTR520.1.00
<b>PORTAUTENSILE PER LAMA DOPPIO CON LUBRIFICAZIONE INTERNA</b> Radial double blade holder with internal coolant Radial Doppel-Abstechhalter mit Innenkuehlung		MTR520.1.04
<b>PORTAUTENSILE PER LAMA DOPPIO E SOVRAPPOSTO</b> Radial double twin-side blade holder Radial Doppel-Abstechhalter ueberlagert		MTR525.1.00
<b>PORTAUTENSILE ASSIALE SINGOLO QD=25mm / QD=1" / QD=20mm / QD=3/4"</b> Axial single static tool QD=25mm / QD=1" / QD=20mm / QD=3/4" Axial Single-Werkzeughalter QD=25mm / QD=1" / QD=20mm / QD=3/4"		MTR552.1.00
<b>PORTAUTENSILE ASSIALE RIBASSATO SINGOLO QD=25mm / QD=20mm</b> Axial single lower height static tool QD=25mm / QD=20mm Axial Single-Werkzeughalter abgeflacht QD=25mm / QD=20mm		MTR562.1.00
<b>PORTAUTENSILE ASSIALE PER BARENO Ø80mm H=110mm</b> Axial single boring bar holder Ø80mm H=110mm Axial Bohrhalter Ø80mm H=110mm		MTR580.1.20
<b>PORTAUTENSILE ASSIALE PER BARENO Ø60mm H=110mm</b> Axial single boring bar holder Ø60mm H=110mm Axial Bohrhalter Ø60mm H=110mm		MTR590.1.20
<b>PORTAUTENSILE ASSIALE PER BARENO Ø50mm / Ø2" H=80mm</b> Axial single boring bar holder Ø50mm / Ø2" H=80mm Axial Bohrhalter Ø50mm / Ø2" H=80mm		MTR610.1.20
<b>PORTAUTENSILE ASSIALE PER BARENO Ø40mm / Ø1 1/2" H=80mm</b> Axial single boring bar holder Ø40mm / Ø1 1/2" H=80mm Axial Bohrhalter Ø40mm / Ø1 1/2" H=80mm		MTR630.1.20
<b>PORTAUTENSILE ASSIALE PROLUNGATO PER BARENO Ø40mm H=115mm</b> Axial single extended boring bar holder Ø40mm H=115mm Axial Bohrhalter verlaengert Ø40mm H=115mm		MTR760.1.10
<b>PORTAUTENSILE ASSIALE PROLUNGATO PER BARENO Ø40mm H=80mm</b> Axial single extended boring bar holder Ø40mm H=80mm Axial Bohrhalter verlaengert Ø40mm H=80mm		MTR760.1.20
<b>PORTAUTENSILE ASSIALE PER BARENO 2+2 POSIZIONI Ø32mm / Ø1 1/4"</b> Axial 2+2 position boring bar holder Ø32mm / Ø1 1/4" Axial Bohrhalter 2+2 Positionen Ø32mm / Ø1 1/4"		MTR872.1.00

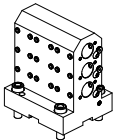
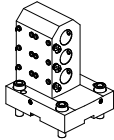
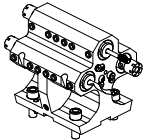
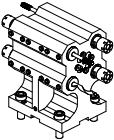
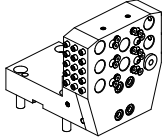
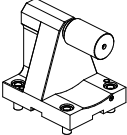
		PAGINA Page Seite
<p><b>PORTAUTENSILE ASSIALE PER BARENO 3+3 POSIZIONI <math>\varnothing</math> 25mm / <math>\varnothing</math> 1"</b>                      Axial 3+3 position boring bar holder <math>\varnothing</math>25mm / <math>\varnothing</math>1"                      Axial Bohrhälter 3+3 Positionen <math>\varnothing</math>25mm / <math>\varnothing</math>1"</p>		MTR894.1.00
<p><b>PORTAUTENSILE ASSIALE ARRETRATO PER BARENO 3 POSIZIONI <math>\varnothing</math> 25mm / <math>\varnothing</math> 1"</b>                      Axial 3 position rear set boring bar holder <math>\varnothing</math>25mm / <math>\varnothing</math>1"                      Axial Bohrhälter 3 Positionen zurueckversetzt <math>\varnothing</math>25mm / <math>\varnothing</math>1"</p>		MTR904.1.00
<p><b>PORTAUTENSILE ASSIALE PER BARENO 3+3 POSIZIONI <math>\varnothing</math> 32mm / <math>\varnothing</math> 1 1/4"</b>                      Axial 3+3 position boring bar holder <math>\varnothing</math>32mm / <math>\varnothing</math>1 1/4"                      Axial Bohrhälter 3+3 Positionen <math>\varnothing</math>32mm / <math>\varnothing</math>1 1/4"</p>		MTR912.1.00
<p><b>PORTAUTENSILE ASSIALE PER BARENO 4+4 POSIZIONI <math>\varnothing</math> 25mm / <math>\varnothing</math> 1"</b>                      Axial 4+4 position boring bar holder <math>\varnothing</math>25mm / <math>\varnothing</math>1"                      Axial Bohrhälter 4+4 Positionen <math>\varnothing</math>25mm / <math>\varnothing</math>1"</p>		MTR922.1.00
<p><b>PORTAUTENSILE ASSIALE PER BARENO 8 POSIZIONI <math>\varnothing</math> 20mm / <math>\varnothing</math> 3/4"</b>                      Axial 8 position boring bar holder <math>\varnothing</math>20mm / <math>\varnothing</math>3/4"                      Axial Bohrhälter 8 Positionen <math>\varnothing</math>20mm / <math>\varnothing</math>3/4"</p>		MTR933.1.00
<p><b>CONTROPUNTA PER CONTROMANDRINO</b>                      Tailstock for subspindle                      Gegenspintz fuer Gegenspindel</p>		MTR950.1.00



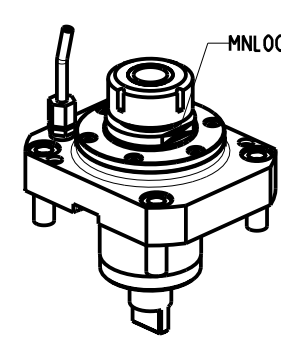
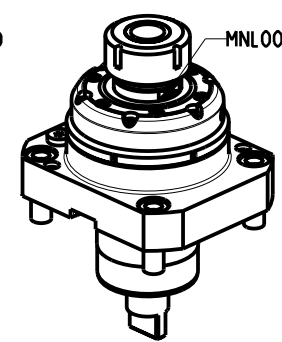
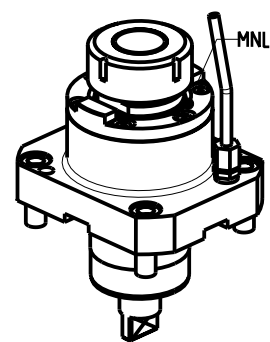
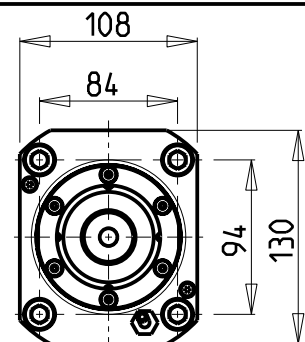
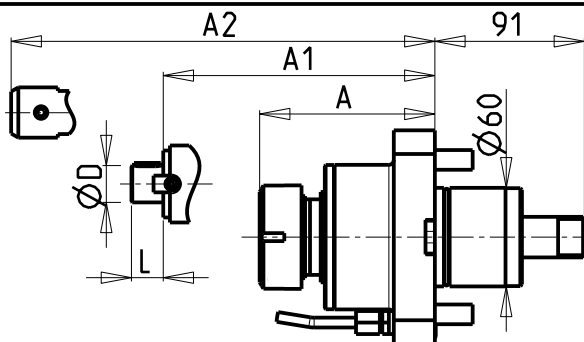

- Chiave inclusa
- Key included
- Schluessel inbegriffen

Cod. MT	Cod. MORI-SEIKI	Mandrino Spindle Spindel	I	RPM	Coppia Max Max Torque Max Drehmoment	Lubrificazione int. Coolant through Innenkuehlung	Lubrificazione est. Ext. coolant Aussenkuehlung	A	A1	A2	D	L	CHIAVI NON INCLUDE Keys not included Schluessel nicht einbegriffen	
MNL0020532	T32206	ER32	1:1	6000	100Nm	-	X	104.16	-	-	-	-	OKU0650004	CHSTER32
MNL0020140	T32213	ER40	1:1	6000	100Nm	-	X	106.66	-	-	-	-	OKU0650004	CHSTER40
MNL0021532	-	ER32	1:1	6000	100Nm	P=30bar	X	104.16	-	-	-	-	OKU0650004	CHSTER32
MNL0021140	-	ER40	1:1	6000	100Nm	P=30bar	X	106.66	-	-	-	-	OKU0650004	CHSTER40
MNL0020632	-	ER32	1:1	6000	100Nm	-	X	144.16	-	-	-	-	OKU0650004	CHSTER32
MNL0021632	-	ER32	1:1	6000	100Nm	P=30bar	X	144.16	-	-	-	-	OKU0650004	CHSTER32
MNL0020732	-	ER32	1:1	6000	100Nm	P=30bar	X	107.66	-	-	-	-	CHUB36	CHSTER32
MNL0021617	-	Ø16x17	1:1	6000	100Nm	-	X	-	116	-	16	17	OKU0650004	CH_VTCROCE_M08
MNL0020116	-	Ø16x17	1:1	6000	100Nm	P=30bar	X	-	116	-	16	17	OKU0650004	CH_VTCROCE_M08
MNL0022219	-	Ø22x19	1:1	6000	100Nm	-	X	-	106	-	22	19	OKU0650004	CH_VTCROCE_M10
MNL0020122	-	Ø22x19	1:1	6000	100Nm	P=30bar	X	-	106	-	22	19	OKU0650004	CH_VTCROCE_M10
MNL0022721	-	Ø27x21	1:1	6000	100Nm	-	X	-	81.5	-	27	21	OKU0650004	CH_VTCROCE_M12
MNL0022519	-	Ø1" x19	1:1	6000	100Nm	-	X	-	81.5	-	1"	21	OKU0650004	CH_VTCROCE_M12
MNL0020525	-	Ø1" x19	1:1	6000	100Nm	P=30bar	X	-	84.5	-	1"	21	OKU0650004	CH_VTCROCE_M12
MNL0022132	-	ER32 CORTO-SHORT-KURZ	1:1	6000	100Nm	-	X	75.76	-	-	-	-	CHUB46	CHSTER32
MNL0022140	-	ER40 CORTO-SHORT-KURZ	1:1	6000	100Nm	-	X	89.66	-	-	-	-	CHUB46	CHSTER40
MNL0020120	-	WELDON 20	1:1	6000	100Nm	-	X	-	-	99.5	-	-	-	-
MNL0020125	-	WELDON 25	1:1	6000	100Nm	-	X	-	-	109	-	-	-	-
MNL0020132	-	WELDON 32	1:1	6000	100Nm	-	X	-	-	125.5	-	-	-	-
MNL0020220	-	WELDON 20	1:1	6000	100Nm	P=30bar	X	-	-	99.5	-	-	-	-
MNL0020425	-	WELDON 25	1:1	6000	100Nm	P=30bar	X	-	-	109	-	-	-	-
MNL0020232	-	WELDON 32	1:1	6000	100Nm	P=30bar	X	-	-	125.5	-	-	-	-

MT RENT  
MT CUT T25Y/SY - MT CUT T32Y/SY

MODULO MOTORIZZATO RADIALE  
Radial driven tool  
Radial angetriebenes Werkzeug

Subject to change without notice.

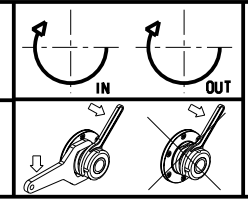

**M.T. srl**  
Via Casino Albini 480  
Tel. 0541/956034-957884  
Fax 0541/956341  
47842 S. GIOVANNI IN M. (RN)  
e-mail: mtma@mtmarchetti.com  
http://www.mtmarchetti.com

PRODUZIONE MODULI ROTANTI

PAGINA MTR010-1-00

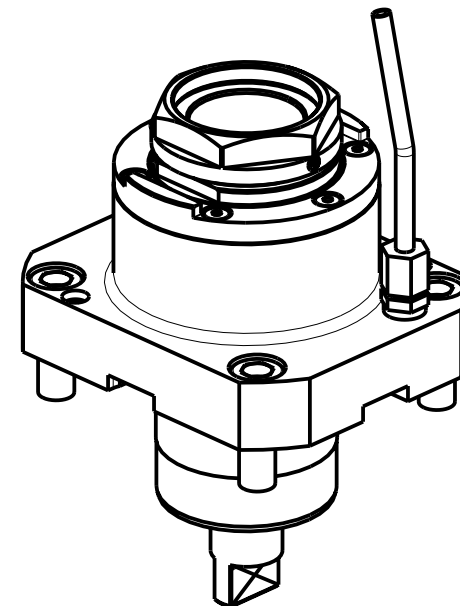
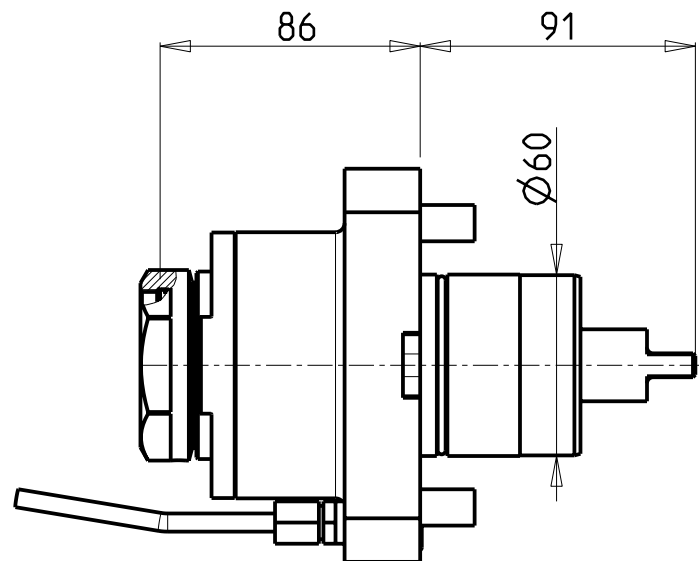
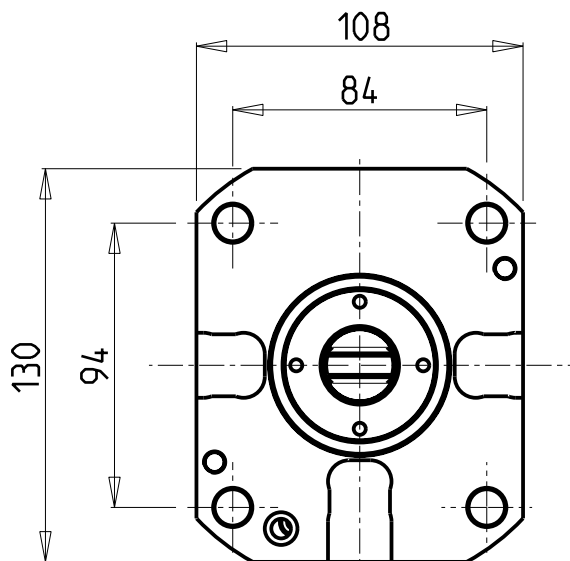

PER PORTAUTENSILI MODULARI MTSK-50 VEDI PAG. TBL300-1-50  
 FOR MTSK-50 QUIK CHANGE TOOLHOLDERS CLAMPINGS SEE PAGE TBL300-1-50  
 FUER MTSK-50 MODULARE WERKZEUGAUFNAHMEN SIEHE SEITE TBL300-1-50

- Chiave inclusa
- Key included
- Schluessel inbegriffen

Cod. MT	Mandrino Spindle Spindel	I	RPM	Coppia Max Max Torque Max Drehmoment	Lubrificazione est. Ext. coolant Aussenkuehlung	CHIAVI NON INCLUSE Keys not included Schluessel nicht einbegriffen	
MNL0590150	MTSK-50	1:1	6000	100Nm	X	CHUB55	OKU0430007 ■

MT RENT  
 MT CUT T25Y/SY - MT CUT T32Y/SY

MODULO MOTORIZZATO RADIALE MTSK  
 Radial MTSK driven tool  
 Radial MTSK angetriebenes Werkzeug

Subject to change without notice.

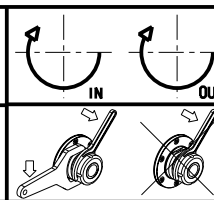

**M.T. srl**  
 Via Casino Albini 480  
 Tel. 0541/956034-957884  
 Fax 0541/956341  
 47842 S. GIOVANNI IN M. (RN)  
 e-mail: mtma@mtmarchetti.com  
 http://www.mtmarchetti.com

PRODUZIONE MODULI ROTANTI



PAGINA MTR010-1-00-K

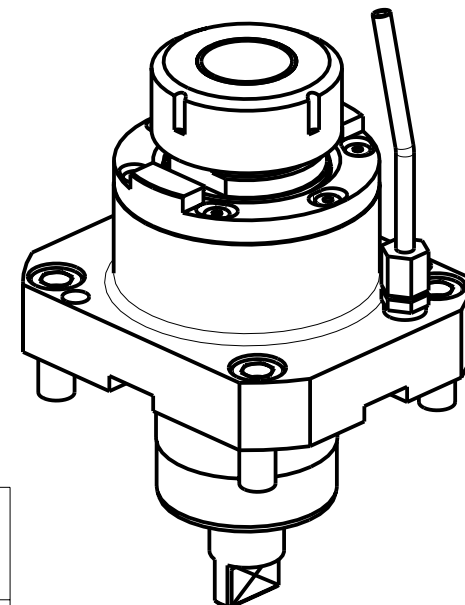
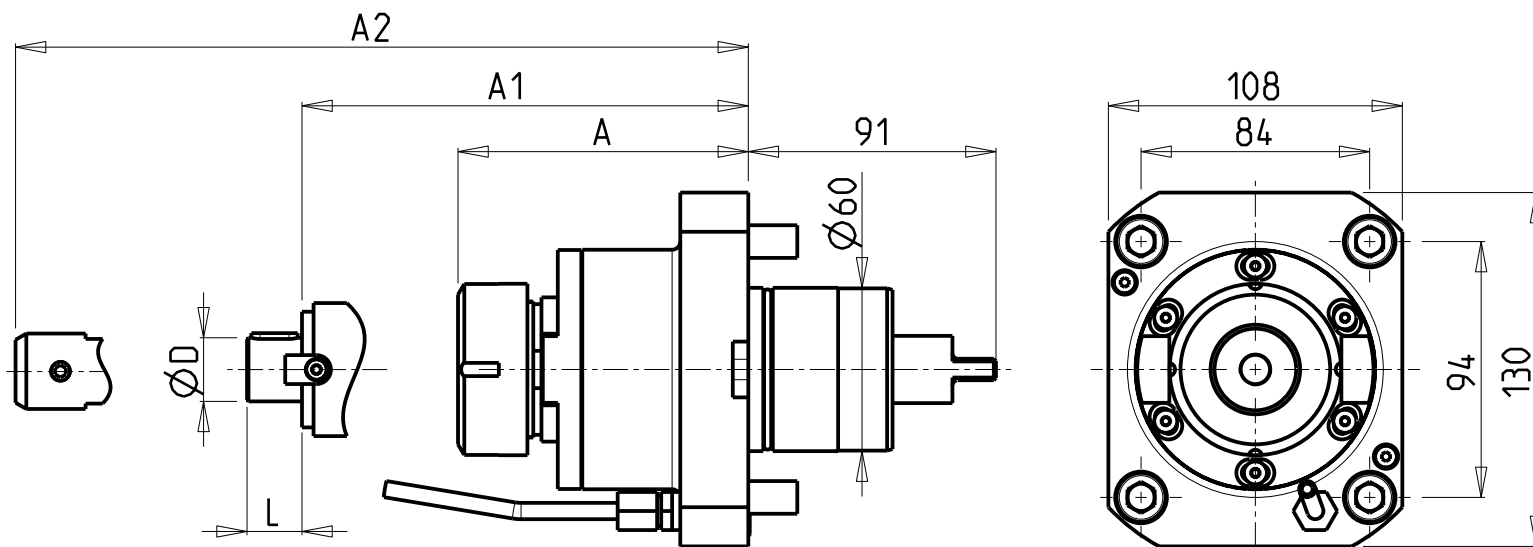

Cod. MT	Mandrino Spindle	I	RPM	Coppia Max Max Torque Max Drehmoment	Lubrificazione est. Ext. coolant Ausseukuehlung	A	A1	A2	D	L	CHIAVI NON INCLUDE Keys not included Schluessel nicht einbegriffen	
MNL0760532	ER32	1:1	10000	100Nm	X	104.16	-	-	-	-	OKU0650004	CHSTER32
MNL0760140	ER40	1:1	10000	100Nm	X	106.66	-	-	-	-	OKU0650004	CHSTER40
MNL0760632	ER32	1:1	10000	100Nm	X	144.16	-	-	-	-	OKU0650004	CHSTER32
MNL0761617	Ø16x17	1:1	10000	100Nm	X	-	116	-	16	17	OKU0650004	CH_VTCROCE_M08
MNL0762219	Ø22x19	1:1	10000	100Nm	X	-	106	-	22	19	OKU0650004	CH_VTCROCE_M10
MNL0762721	Ø27x21	1:1	10000	100Nm	X	-	81.5	-	27	21	OKU0650004	CH_VTCROCE_M12
MNL0762519	Ø1"x19	1:1	10000	100Nm	X	-	81.5	-	1"	21	OKU0650004	CH_VTCROCE_M12
MNL0760120	WELDON 20	1:1	10000	100Nm	X	-	-	99.5	-	-	-	-
MNL0760125	WELDON 25	1:1	10000	100Nm	X	-	-	109	-	-	-	-
MNL0760132	WELDON 32	1:1	10000	100Nm	X	-	-	125.5	-	-	-	-

- Chiave inclusa
- Key included
- Schluessel inbegriffen

MT RENT  
MT CUT T25Y/SY - MT CUT T32Y/SY

MODULO MOTORIZZATO RADIALE 10000 RPM  
Radial driven tool 10000 rpm  
Radial angetriebenes Werkzeug 10000 rpm

Subject to change without notice.

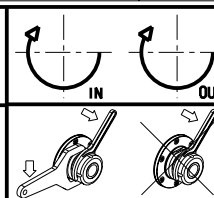

**M.T. srl**  
Via Casino Albini 480  
Tel. 0541/956034-957884  
Fax 0541/956341  
47842 S. GIOVANNI IN M. (RN)  
e-mail: mtma@mtmarchetti.com  
http://www.mtmarchetti.com

PRODUZIONE MODULI ROTANTI



PAGINA MTR010-1-01

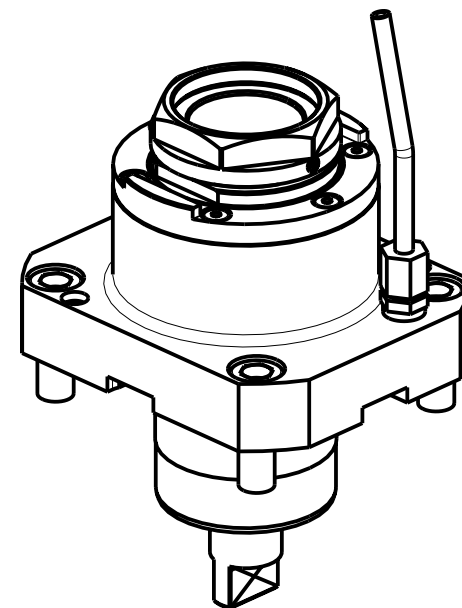
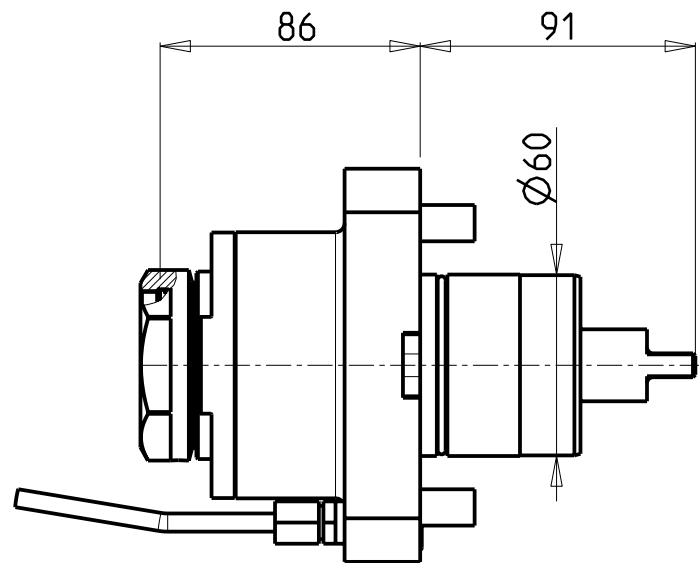
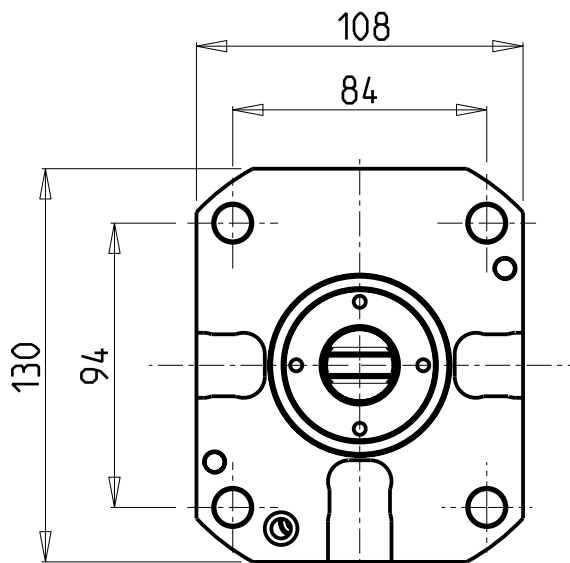

PER PORTAUTENSILI MODULARI MTSK-50 VEDI PAG. TBL300-1-50  
 FOR MTSK-50 QUICK CHANGE TOOLHOLDERS CLAMPINGS SEE PAGE TBL300-1-50  
 FUER MTSK-50 MODULARE WERKZEUGAUFNAHMEN SIEHE SEITE TBL300-1-50

Cod. MT	Mandrino Spindle Spindel	I	RPM	Coppia Max Max Torque Max Drehmoment	Lubrificazione est. Ext. coolant Ausseenkuehlung	CHIAVI NON INCLUSE Keys not included Schlüssel nicht einbegriffen	
						CHUB55	OKU0430007
MNL0790150	MTSK-50	1:1	10000	100Nm	X		

- Chiave inclusa
- Key included
- Schlüssel inbegriffen

MT RENT  
 MT CUT T25Y/SY - MT CUT T32Y/SY

MODULO MOTORIZZATO RADIALE MTSK 10000 RPM  
 Radial MTSK driven tool 10000 rpm  
 Radial MTSK angetriebenes Werkzeug 10000 rpm

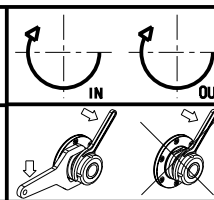

**M.T. srl**  
 Via Casino Albini 480  
 Tel. 0541/956034-957884  
 Fax 0541/956341  
 47842 S. GIOVANNI IN M. (RN)  
 e-mail: mtma@mtmarchetti.com  
 http://www.mtmarchetti.com

PRODUZIONE MODULI ROTANTI



PAGINA MTR010-1-01-K

Subject to change without notice.

10/2018



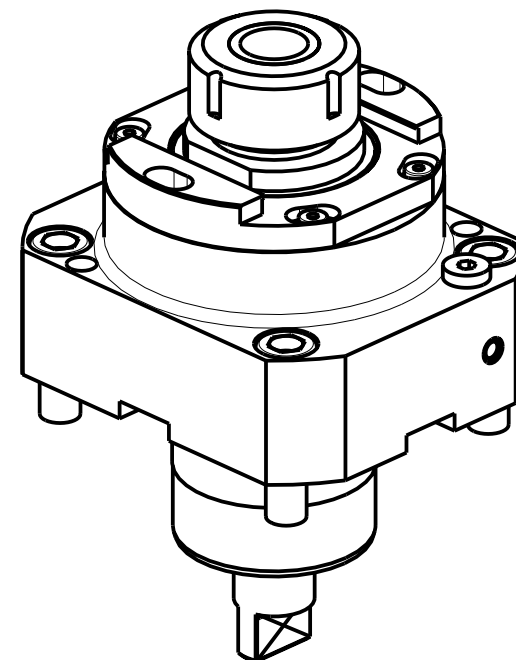
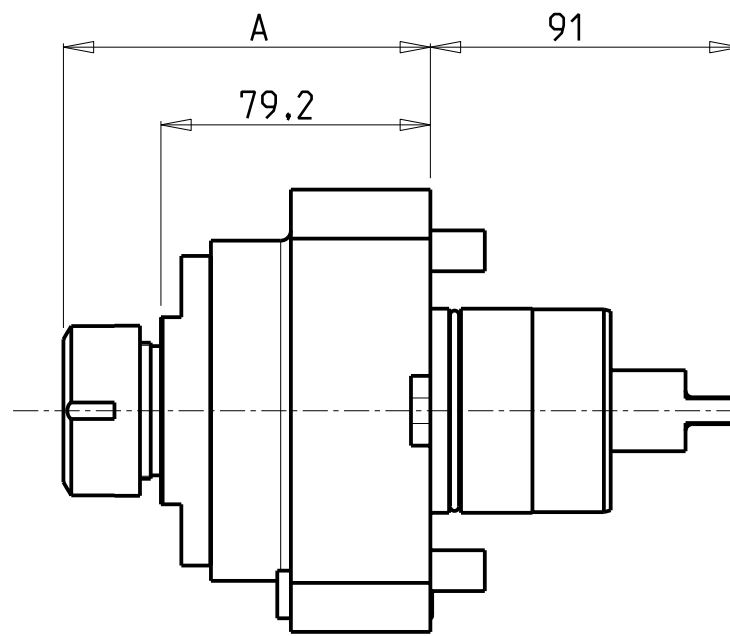
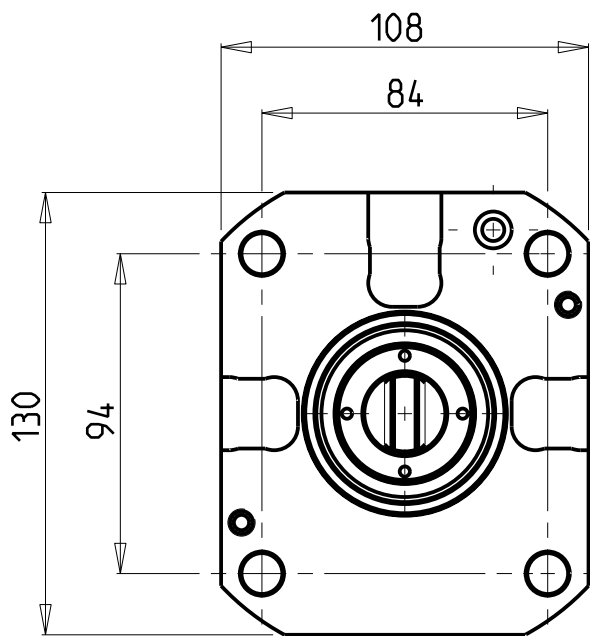



Cod. MT	Mandrino Spindle Spindel	I	RPM	Coppia Max Max Torque Max Drehmoment	Lubrificazione int. Coolant through Innenkuehlung	Lubrificazione est. Ext. coolant Aussenkuehlung	A	CHIAVI NON INCLUSE Keys not included Schluessel nicht einbegriffen	
MNL0570125	ER25	1:1	6000	100Nm	P=80bar	X	104.8	OKU0650004	CHSTER25
MNL0570132	ER32	1:1	6000	100Nm	P=80bar	X	107.8	OKU0650004	CHSTER32

- Chiave inclusa
- Key included
- Schluessel inbegriffen

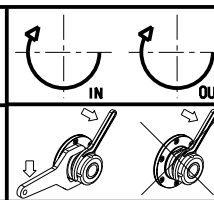
MT RENT  
 MT CUT T25Y/SY - MT CUT T32Y/SY  
 MODULO MOTORIZZATO RADIALE ALTA PRESSIONE  
 Radial driven tool high pressure  
 Radial angetriebenes Werkzeug hochdruck



**M.T. srl**  
 Via Casino Albini 480  
 Tel. 0541/956034-957884  
 Fax 0541/956341  
 47842 S. GIOVANNI IN M. (RN)  
 e-mail: mtma@mtmarchetti.com  
 http://www.mtmarchetti.com

PRODUZIONE MODULI ROTANTI  
  
 PAGINA MTR010-1-20

Subject to change without notice.

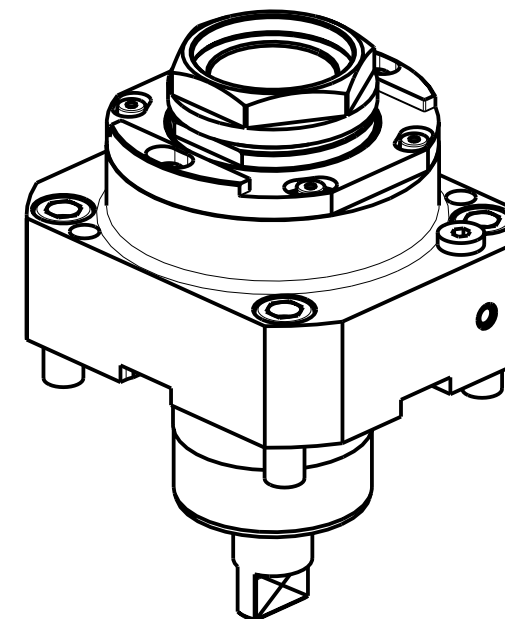
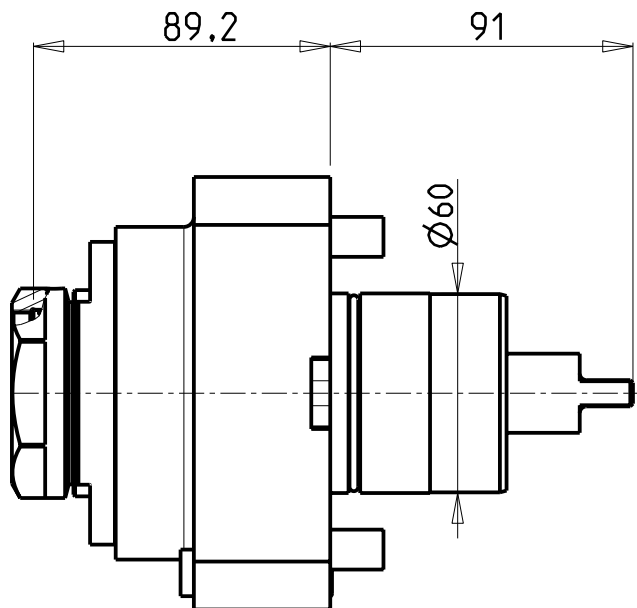
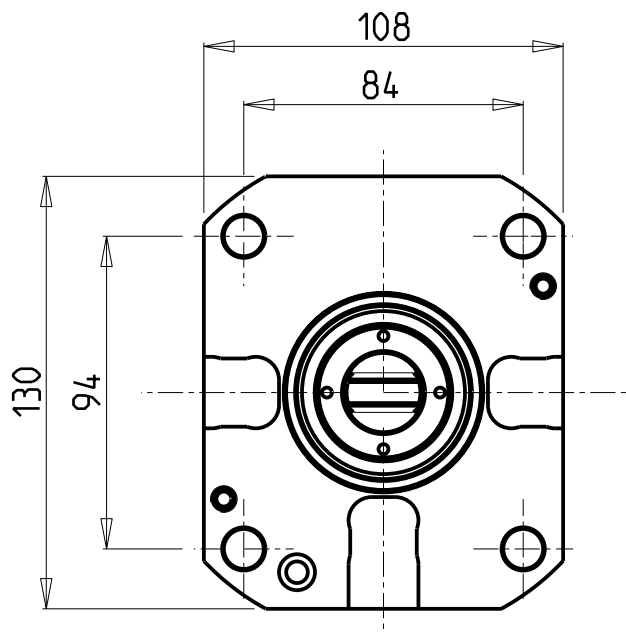

PER PORTAUTENSILI MODULARI MTSK-50 VEDI PAG. TBL300-1-50  
 FOR MTSK-50 QUICK CHANGE TOOLHOLDERS CLAMPINGS SEE PAGE TBL300-1-50  
 FUER MTSK-50 MODULARE WERKZEUGAUFNAHMEN SIEHE SEITE TBL300-1-50

- Chiave inclusa
- Key included
- Schlüssel inbegriffen

Cod. MT	Mandrino Spindle Spindel	I	RPM	Coppia Max Max Torque Max Drehmoment	Lubrificazione int. Coolant through Innenkuehlung	Lubrificazione est. Ext. coolant Aussenkuehlung	CHIAVI NON INCLUSE Keys not included Schlüssel nicht einbegriffen	
							CHUB55	OKU0430007
MNL0590250	MTSK-50	1:1	6000	100Nm	P=80bar	X	CHUB55	OKU0430007

MT RENT  
 MT CUT T25Y/SY - MT CUT T32Y/SY

MODULO MOTORIZZATO RADIALE MTSK ALTA PRESSIONE  
 Radial MTSK driven tool high pressure  
 Radial MTSK angetriebenes Werkzeug hochdruck

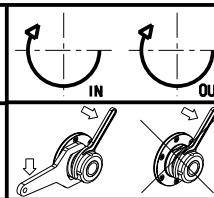

**M.T. srl**  
 Via Casino Albini 480  
 Tel. 0541/956034-957884  
 Fax 0541/956341  
 47842 S. GIOVANNI IN M. (RN)  
 e-mail: mtma@mtmarchetti.com  
 http://www.mtmarchetti.com

PRODUZIONE MODULI ROTANTI



PAGINA MTR010-1-20-K

Subject to change without notice.

10/2018

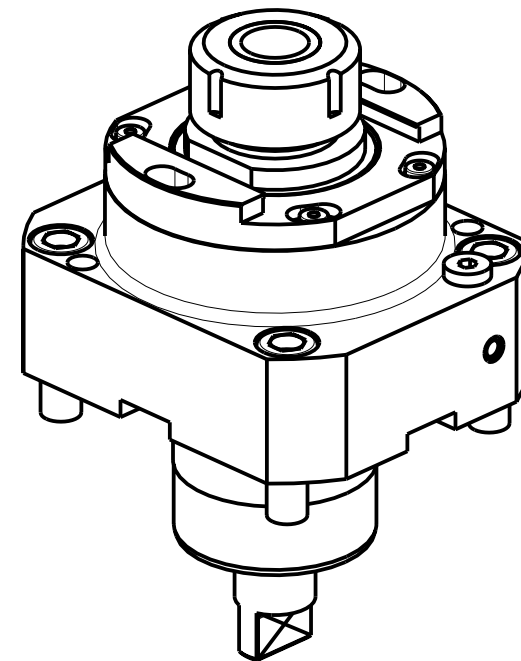
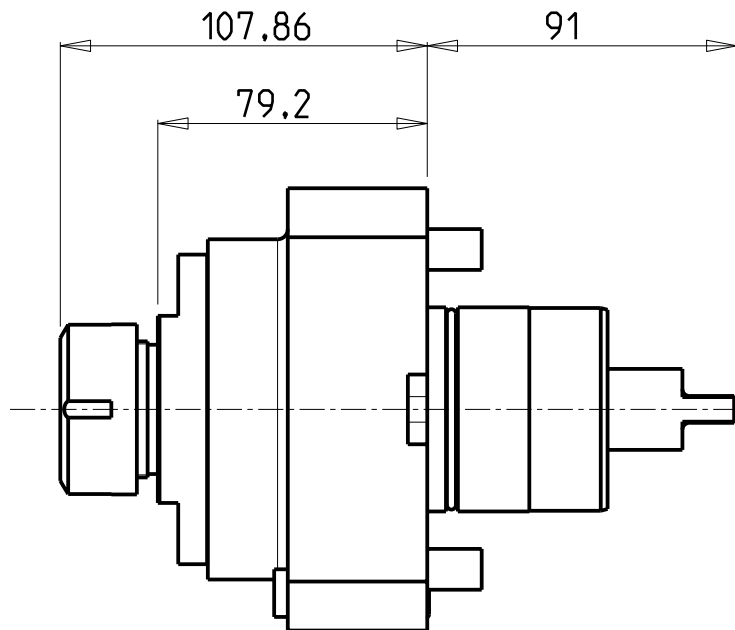
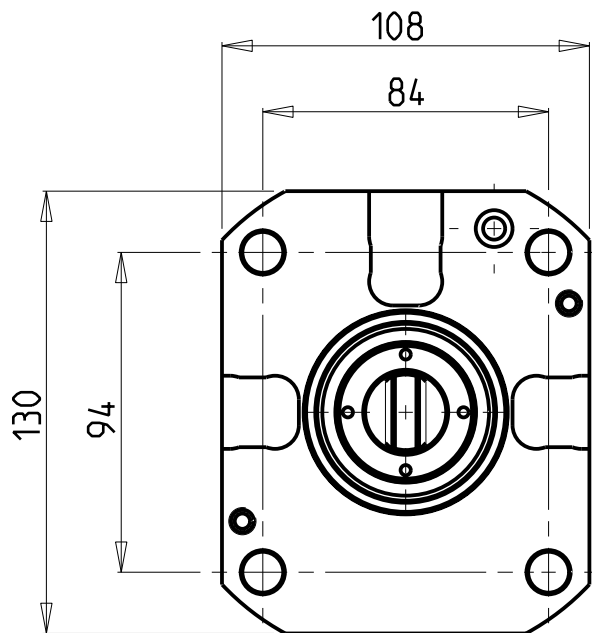

Cod. MT	Mandrino Spindle Spindel	I	RPM	Coppia Max Max Torque Max Drehmoment	Lubrificazione int. Coolant through Innenkuehlung	Lubrificazione est. Ext. coolant Aussenkuehlung	CHIAVI NON INCLUSE Keys not included Schluessel nicht einbegriffen	
MNL0770125	ER25	1:1	10000	100Nm	P=30bar	X	OKU0650004 *	CHSTER25
MNL0770132	ER32	1:1	10000	100Nm	P=30bar	X	OKU0650004 *	CHSTER32

• Chiave inclusa
• Key included
• Schluessel inbegriffen

MT RENT  
MT CUT T25Y/SY - MT CUT T32Y/SY

MODULO MOTORIZZATO RADIALE 10000 RPM  
Radial driven tool 10000 rpm  
Radial angetriebenes Werkzeug 10000 rpm

Subject to change without notice.

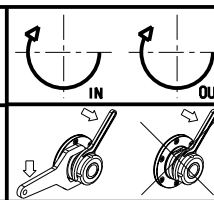

**M.T. srl**  
Via Casino Albini 480  
Tel. 0541/956034-957884  
Fax 0541/956341  
47842 S. GIOVANNI IN M. (RN)  
e-mail: mtma@mtmarchetti.com  
http://www.mtmarchetti.com

PRODUZIONE MODULI ROTANTI



PAGINA MTR010-1-21

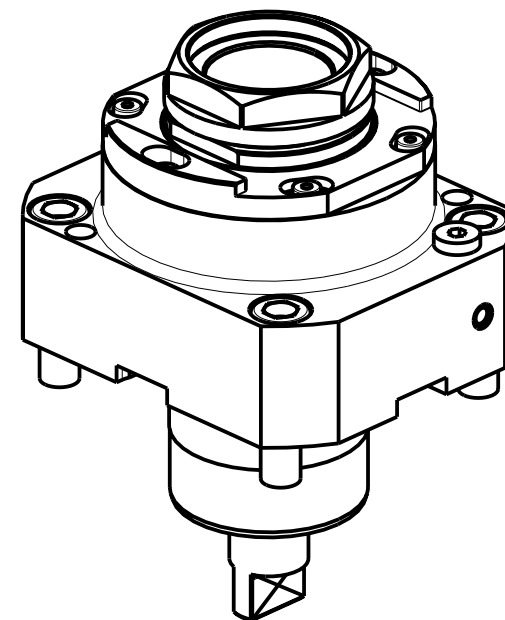
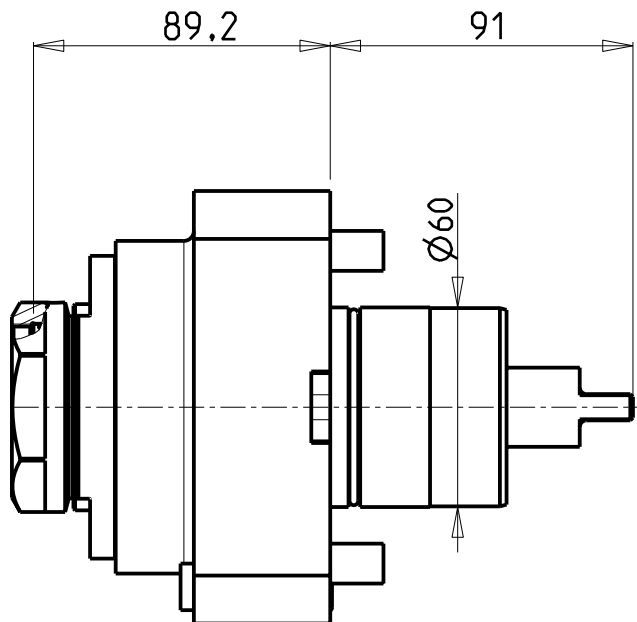
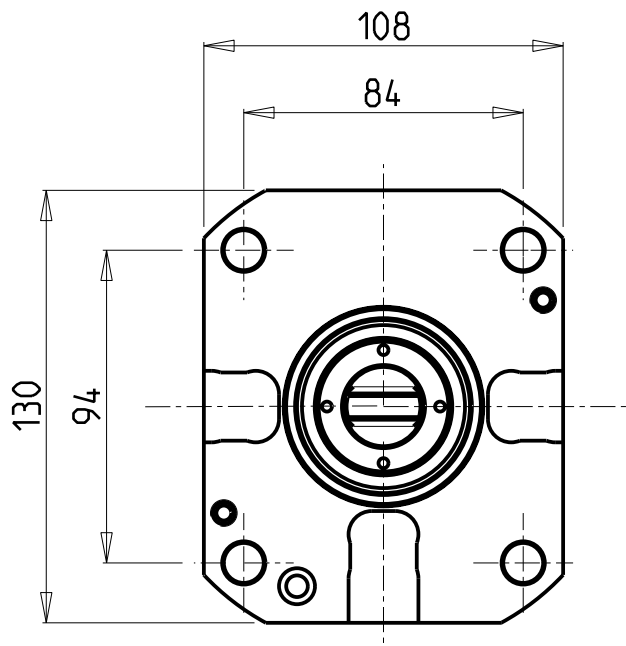

PER PORTAUTENSILI MODULARI MTSK-50 VEDI PAG. TBL300-1-50  
 FOR MTSK-50 QUICK CHANGE TOOLHOLDERS CLAMPINGS SEE PAGE TBL300-1-50  
 FUER MTSK-50 MODULARE WERKZEUGAUFNAHMEN SIEHE SEITE TBL300-1-50

Cod. MT	Mandrino Spindle Spindel	I	RPM	Coppia Max Max Torque Max Drehmoment	Lubrificazione int. Coolant through Innenkuehlung	Lubrificazione est. Ext. coolant Aussenkuehlung	CHIAVI NON INCLUSE Keys not included Schlüssel nicht einbegriffen	
MNL0790250	MTSK-50	1:1	10000	100Nm	P=30bar	X	CHUB55	OKU0430007 ▪

- Chiave inclusa
- Key included
- Schlüssel inbegriffen

MT RENT  
 MT CUT T25Y/SY - MT CUT T32Y/SY

MODULO MOTORIZZATO RADIALE MTSK 10000 RPM  
 Radial MTSK driven tool 10000 rpm  
 Radial MTSK angetriebenes Werkzeug 10000 rpm

Subject to change without notice.

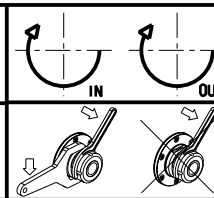

**M.T. srl**  
 Via Casino Albini 480  
 Tel. 0541/956034-957884  
 Fax 0541/956341  
 47842 S. GIOVANNI IN M. (RN)  
 e-mail: mtma@mtmarchetti.com  
 http://www.mtmarchetti.com

PRODUZIONE MODULI ROTANTI



PAGINA MTR010-1-21-K

## CUSCINETTI MAGGIORATI PER LAVORAZIONI PESANTI

Reinforced bearings for  
heavy machining

Vergroesserte Lager fuer  
schwerere Bearbeitungen

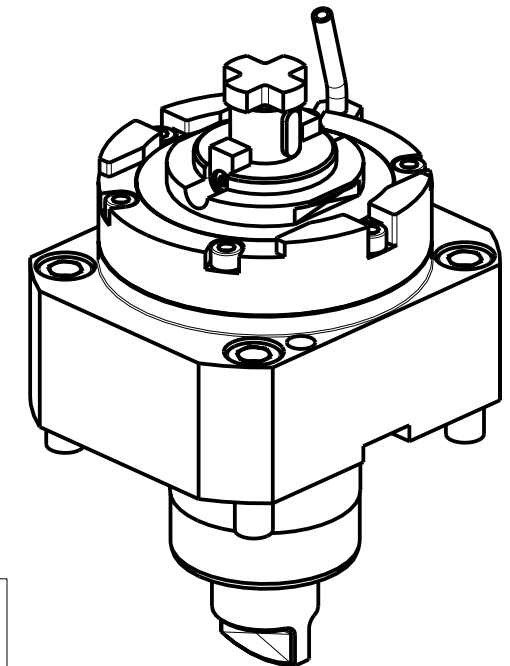
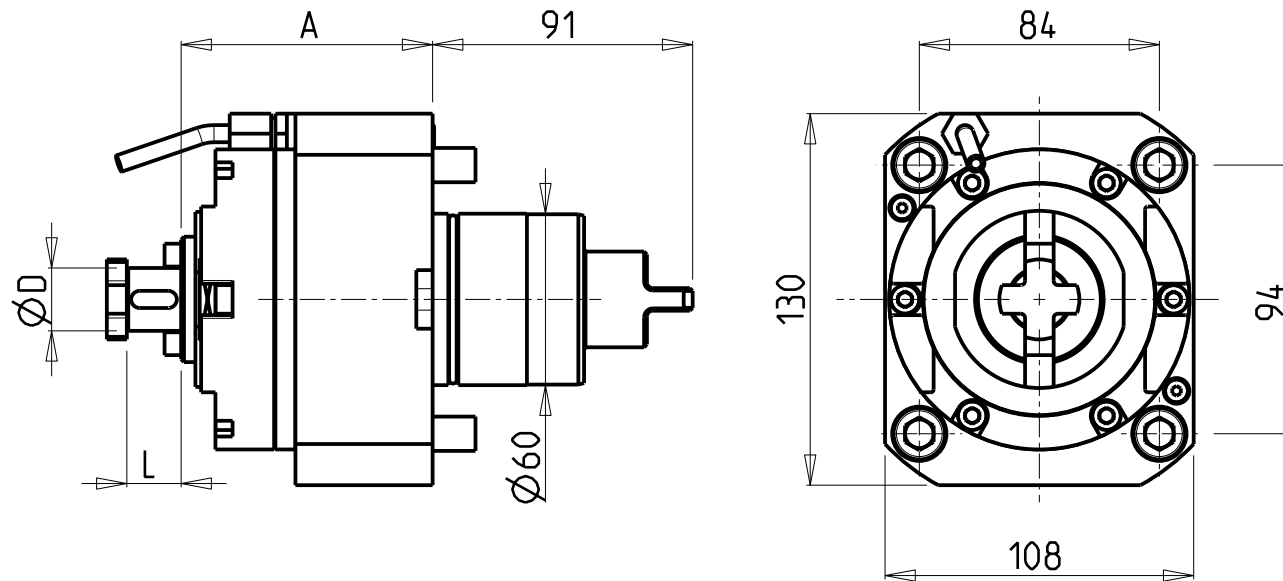

Cod. MT	Mandrino Spindle Spindel	I	RPM MAX	Coppia Max Max Torque Max Drehmoment	Lubrificazione est. Ext. coolant Auslenkuehlung	A	D	L	CHIAVI INCLUSE Keys included Schluessel inbegriffen	
MNL0732219	Ø22x19	1:1	4000	100Nm	X	88	22	19	CH_VTCROCE_M10	OKU0430007
MNL0732519	Ø1" x19	1:1	4000	100Nm	X	89	1"	19	CH_VTCROCE_M12	OKU0430007
MNL0732721	Ø27x21	1:1	4000	100Nm	X	89	27	21	CH_VTCROCE_M12	OKU0430007
MNL0733224	Ø32x24	1:1	4000	100Nm	X	91	32	24	CH_VTCROCE_M16	OKU0430007

MT RENT  
MT CUT T25Y/SY - MT CUT T32Y/SY

MODULO MOTORIZZATO RADIALE MAGGIORATO  
Radial reinforced driven tool  
Radial angetriebenes Werkzeug vergroessert

Subject to change without notice.

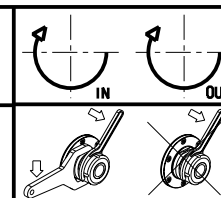

**M.T. srl**

Via Casino Albini 480  
Tel. 0541/956034-957884  
Fax 0541/956341  
47842 S. GIOVANNI IN M. (RN)  
e-mail: mtma@mtmarchetti.com  
http://www.mtmarchetti.com

PRODUZIONE MODULI ROTANTI



PAGINA MTR020-1-00

**CUSCINETTI MAGGIORATI  
PER LAVORAZIONI PESANTI**

Reinforced bearings for  
heavy machining

Vergroesserte Lager fuer  
schwerere Bearbeitungen

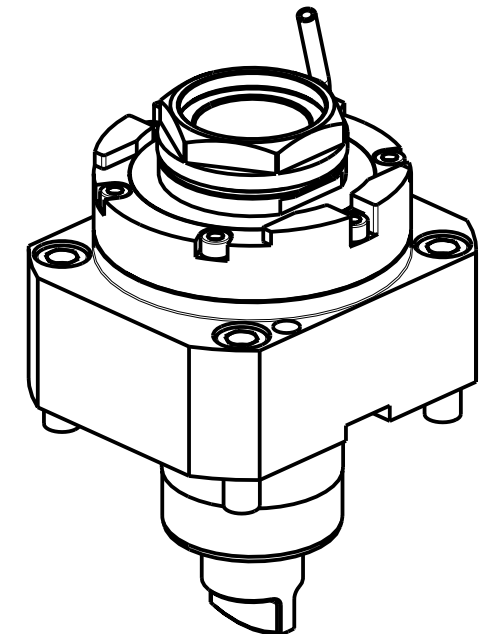
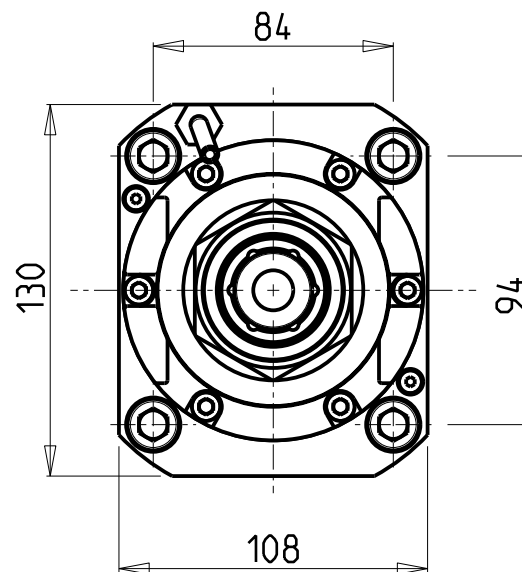
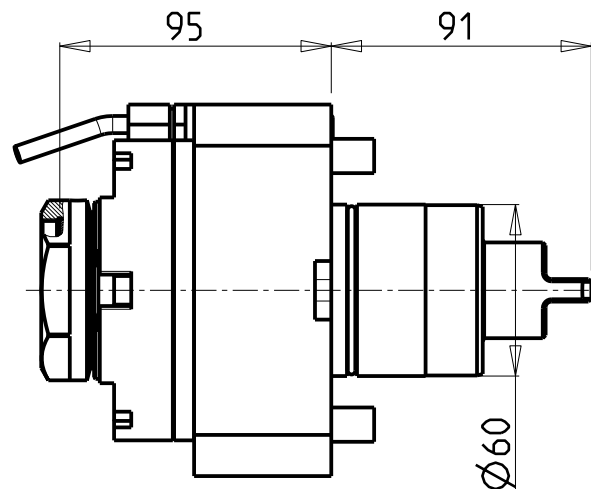

- Chiave inclusa
- Key included
- Schluessel inbegriffen

PER PORTAUTENSILI MODULARI MTSK-50 VEDI PAG. TBL300-1-50  
FOR MTSK-50 QUIK CHANGE TOOLHOLDERS CLAMPINGS SEE PAGE TBL300-1-50  
FUER MTSK-50 MODULARE WERKZEUGAUFNAHMEN SIEHE SEITE TBL300-1-50

Cod. MT	Mandrino Spindle Spindel	I	RPM MAX	Coppia Max Max Torque Max Drehmoment	Lubrificazione est. Ext. coolant Aussenkuehlung	CHIAVI NON INCLUSE Keys not included Schluessel nicht einbegriffen	
MNL0740150	MTSK-50	1:1	4000	100Nm	X	CHUB55	OKU0430007 ▪

MT RENT  
MT CUT T25Y/SY - MT CUT T32Y/SY

MODULO MOTORIZZATO RADIALE MAGGIORATO MTSK  
Radial MTSK reinforced driven tool  
Radial MTSK angetriebenes Werkzeug vergroessert

Subject to change without notice.

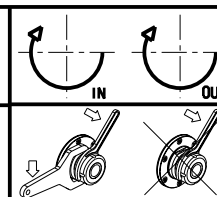

**M.T. srl**  
Via Casino Albini 480  
Tel. 0541/956034-957884  
Fax 0541/956341  
47842 S. GIOVANNI IN M. (RN)  
e-mail: mtma@mtmarchetti.com  
http://www.mtmarchetti.com

PRODUZIONE MODULI ROTANTI



PAGINA MTR020-1-00-K

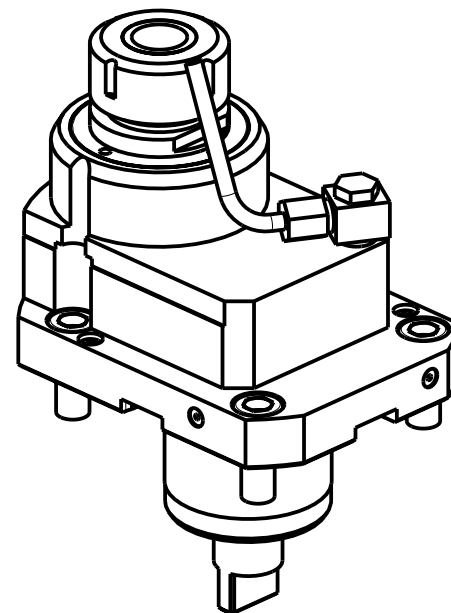
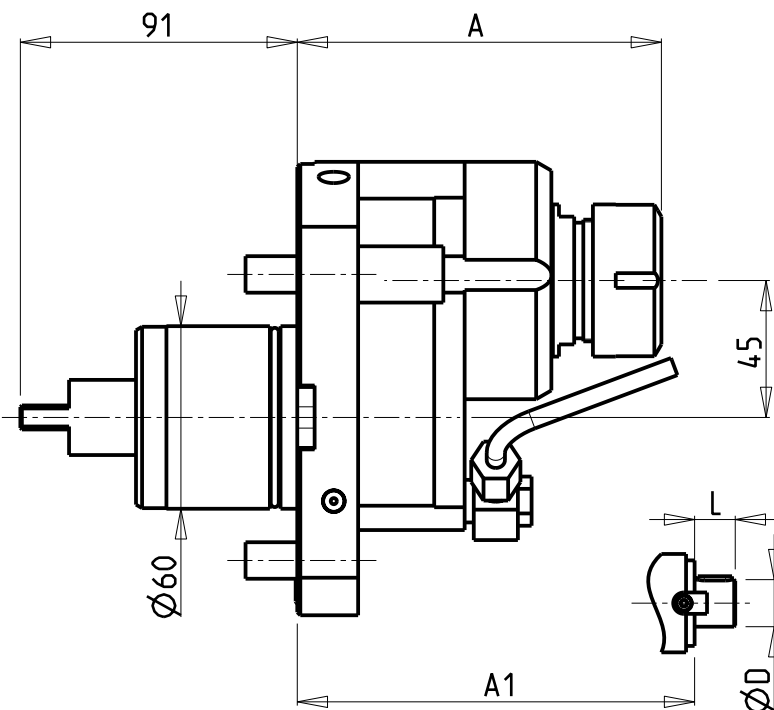
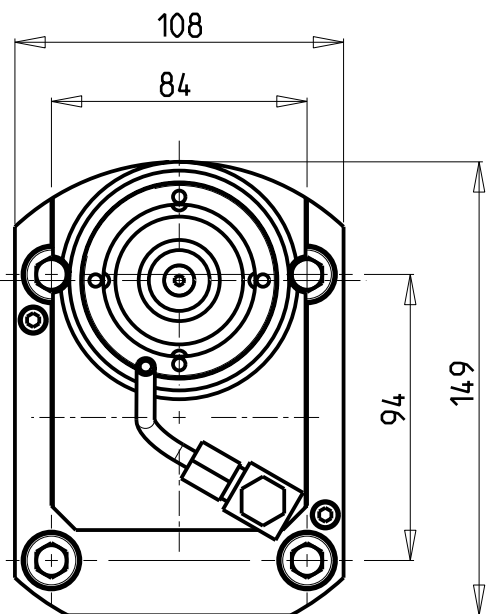

- Chiave inclusa
- Key included
- Schlüssel inbegriffen

Cod. MT	Mandrino Spindle Spindel	i	RPM	Coppia Max Max Torque Max Drehmoment	Reversibile lato mandrino/contromandrino Reversible sub/main spindle side Umkehrbare Spindel-seite/ Gegenspindel-seite	Lubr.esterna Ext. coolant Aussehenkuehlung	A	A1	D	L	CHIAVI NON INCLUDE Keys not included Schlüssel nicht einbegriffen	
											CHUB36	CHSTER32
MNL0342132	ER32	2:1	3000	100Nm	X	X	119.66	-	-	-	CHUB36	CHSTER32
MNL0342122	Ø22x19	2:1	3000	100Nm	X	X	-	98	22	19	CHUB36	CH_VTCROCE_M10 ▪
MNL0342127	Ø27x21	2:1	3000	100Nm	X	X	-	98	27	21	CHUB36	CH_VTCROCE_M12 ▪
MNL0342119	Ø3/4"x3/4"	2:1	3000	100Nm	X	X	-	98	3/4"	3/4"	CHUB36	CH_VTCROCE_M08 ▪
MNL0342125	Ø1"x19	2:1	3000	100Nm	X	X	-	98	1"	19	CHUB36	CH_VTCROCE_M12 ▪

MT RENT  
MT CUT T25Y/SY - MT CUT T32Y/SY

MODULO MOTORIZZATO RADIALE RIDOTTO I=2:1 DISASSATO IN Z 45mm  
Radial geared-down I=2:1 driven tool re-directed in Z by 45mm  
Radial angetriebenes Werkzeug untersetzt I=2:1 achsversetzt in Z um 45mm

Subject to change without notice.

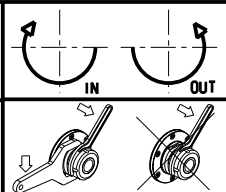

**M.T. srl**  
Via Casino Albini 480  
Tel. 0541/956034-957884  
Fax 0541/956341  
47842 S. GIOVANNI IN M. (RN)  
e-mail: mtma@mtmarchetti.com  
http://www.mtmarchetti.com

PRODUZIONE MODULI ROTANTI



PAGINA MTR030-1-20

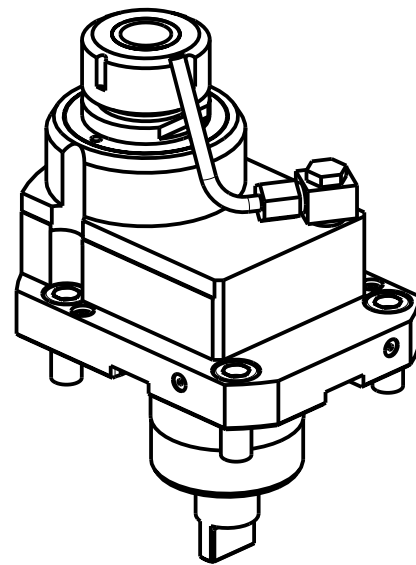
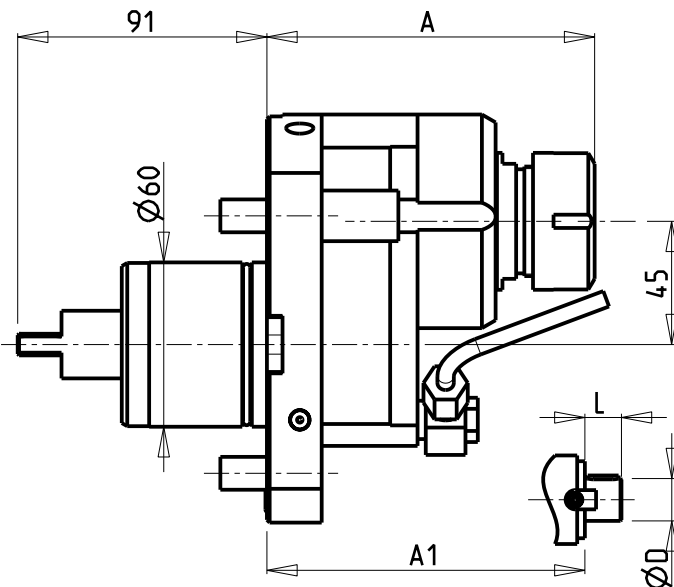
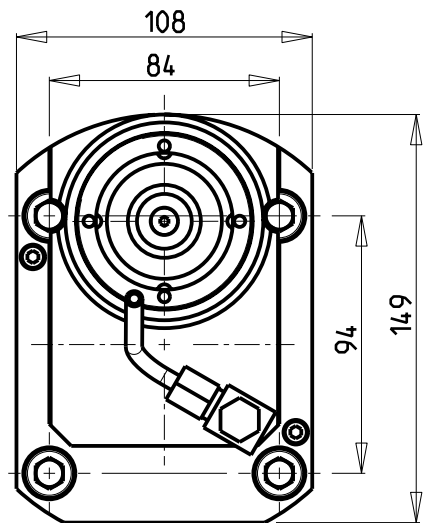

- Chiave inclusa
- Key included
- Schlüssel inbegriffen

Cod. MT	Mandrino Spindle Spindel	I	RPM	Coppia Max Max Torque Max Drehmoment	Reversibile lato mandrino/contromandrino Reversible sub/main spindle side Umkehrbare Spindel-seite/ Gegenspindel-seite	Lubrificazione int. Coolant through Innenkuehlung	Lubr. esterna Ext. coolant Aussenkuehlung	A	A1	D	L	CHIAVI NON INCLUDE Keys not included Schlüssel nicht inbegriffen	
												CHUB42	CHSTER20
MNL0340120	ER20	1:1	6000	100Nm	X	-	X	115.66	-	-	-	CHUB42	CHSTER20
MNL0340032	ER32	1:1	6000	100Nm	X	-	X	119.66	-	-	-	CHUB42	CHSTER32
MNL0340220	ER20	1:1	6000	100Nm	X	P=70bar	X	126.66	-	-	-	CHUB42	CHSTER20
MNL0340132	ER32	1:1	6000	100Nm	X	P=70bar	X	131.16	-	-	-	CHUB42	CHSTER32
MNL0341116	Ø16x17	1:1	6000	100Nm	X	-	X	-	98	16	17	CHUB42	CH_VTCROCE_M08
MNL0341122	Ø22x19	1:1	6000	100Nm	X	-	X	-	98	22	19	CHUB42	CH_VTCROCE_M10
MNL0341127	Ø27x21	1:1	6000	100Nm	X	-	X	-	98	27	21	CHUB42	CH_VTCROCE_M12
MNL0341119	Ø3/4"x3/4"	1:1	6000	100Nm	X	-	X	-	98	3/4"	3/4"	CHUB42	CH_VTCROCE_M08
MNL0342225	Ø1"x19	1:1	6000	100Nm	X	-	X	-	98	1"	19	CHUB42	CH_VTCROCE_M12

MT RENT  
MT CUT T25Y/SY - MT CUT T32Y/SY

MODULO MOTORIZZATO RADIALE DISASSATO IN Z 45mm  
Radial driven tool re-directed in Z by 45mm  
Radial angetriebenes Werkzeug achsversetzt in Z um 45mm

Subject to change without notice.

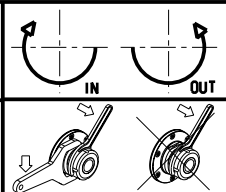

**M.T. srl**  
Via Casino Albini 480  
Tel. 0541/956034-957884  
Fax 0541/956341  
47842 S. GIOVANNI IN M. (RN)  
e-mail: mtma@mtmarchetti.com  
http://www.mtmarchetti.com

PRODUZIONE MODULI ROTANTI



PAGINA MTR033-1-10



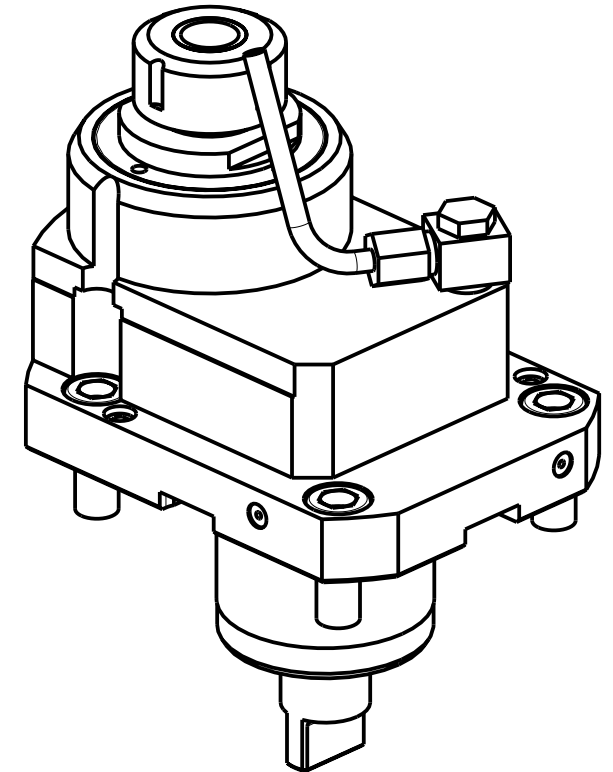
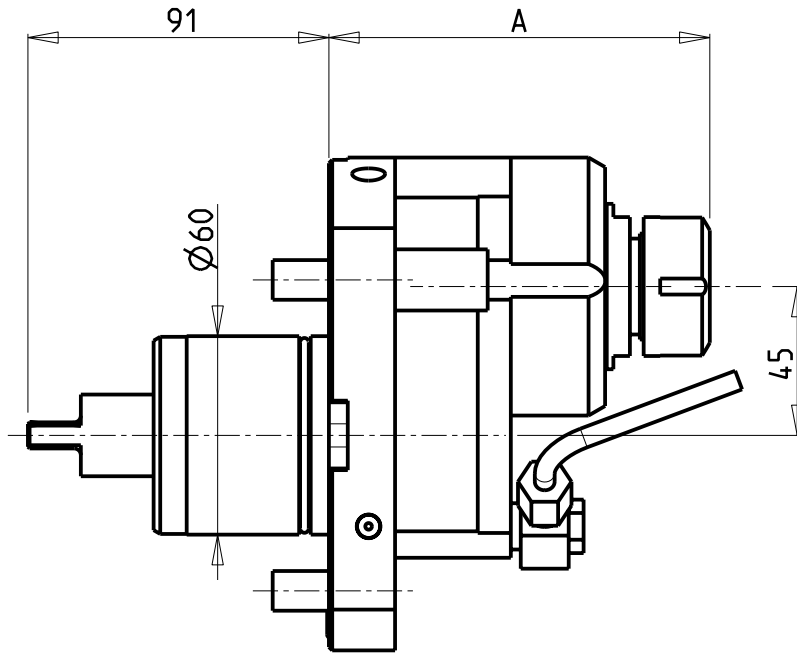
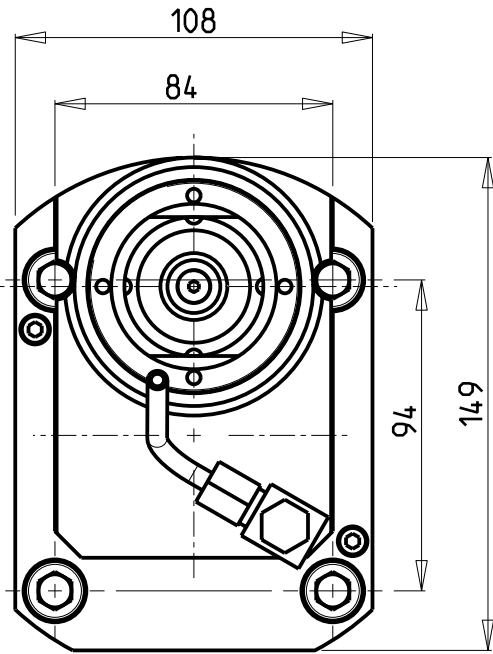

Cod. MT	Mandrino Spindle Spindel	i	RPM MAX	Coppia Max Max Torque Max Drehmoment	Reversibile lato mandrino/contromandrino Reversible sub/main spindle side Umkehrbare Spindel-seite/ Gegenspindel-seite	Lubrificazione int. Coolant through Innenkuehlung	Lubrificazione est. Ext. coolant Aussenkuehlung	A	CHIAVI NON INCLUSE Keys not included Schlüssel nicht einbegriffen	
MNL0341225	ER25	1:2	12000	40Nm	X		X	115.16	CHUB42	CHSTER25
MNL0342425	ER25	1:2	10000	40Nm	X	P=70bar	X	126.16	CHUB42	CHSTER25

**MT RENT**  
**MT CUT T25Y/SY - MT CUT T32Y/SY**

MODULO MOTORIZZATO RADIALE MOLTIPLICATO I=1:2 DISASSATO IN Z 45mm  
 Radial geared-up I=1:2 driven tool re-directed in Z by 45mm  
 Radial angetriebenes Werkzeug uebersetzt I=1:2 achsversetzt in Z um 45mm

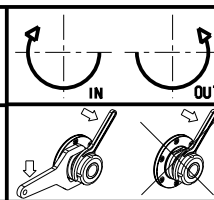

**M.T. srl**  
 Via Casino Albini 480  
 Tel. 0541/956034-957884  
 Fax 0541/956341  
 47842 S. GIOVANNI IN M. (RN)  
 e-mail: mtma@mtmarchetti.com  
 http://www.mtmarchetti.com

PRODUZIONE MODULI ROTANTI



PAGINA MTR033-1-30

Subject to change without notice.

10/2018

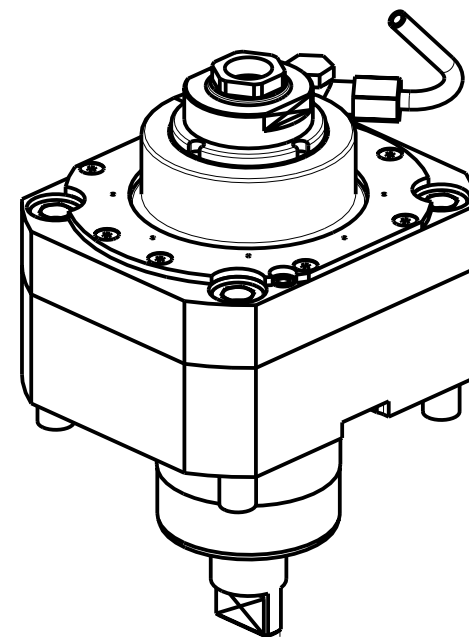
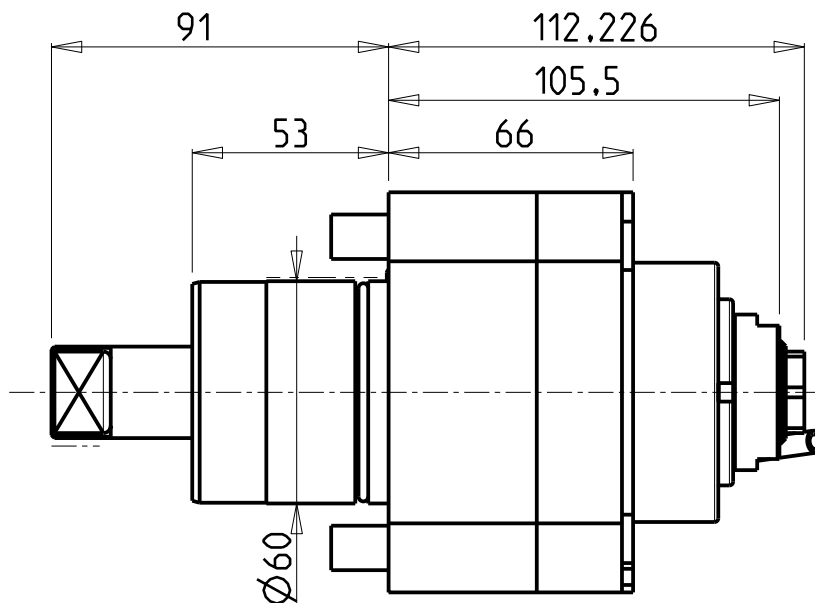
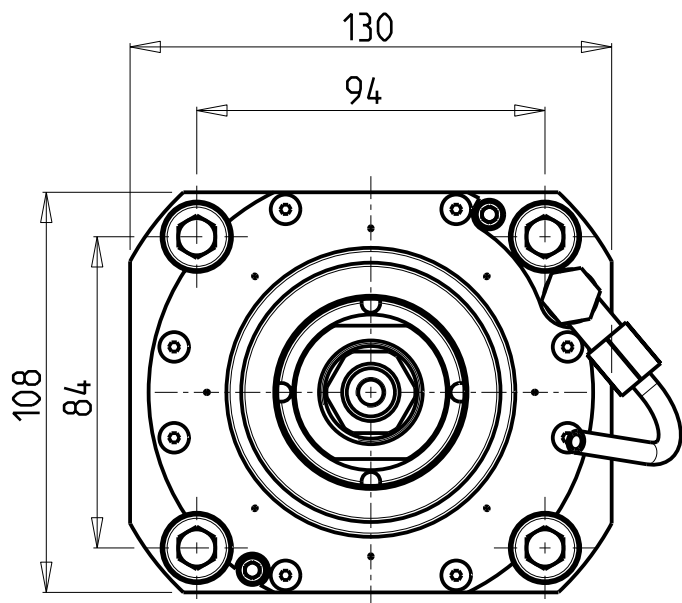

**ATTENZIONE - ATTENTION - ACHTUNG**

- PRIMA DI UTILIZZARE IL MOTORIZZATO CONSULTARE LE ISTRUZIONI ALLEGATE!
- BEFORE USING THE DRIVEN TOOL, PLEASE CHECK THE ENCLOSED INSTRUCTION SHEET!
- VOR DER BENUTZUNG DES ANGETRIEBENEN WERKZEUGES, DIE BEILIEGENDEN INSTRUKTIONEN DURCHLESEN!

**ATTENZIONE - ATTENTION - ACHTUNG**

- Per lo smontaggio degli utensili utilizzare sempre la chiave di contrasto come indicato nel manuale d'uso.
- For disassembly of the tools use always the contrast key as mentioned in the user instructions.
- Fuer das Abmontieren der Werkzeuge immer den Gegenschlüssel benutzen wie in der Bedienungsanleitung erwaeht.

Cod. MT	Mandrino Spindle Spindel	I	RPM	Coppia Max Max Torque Max Drehmoment	Lubrificazione est. Ext. coolant Aussenkuehlung	CHIAVI INCLUSE Keys included Schluessel einbegriffen	
MNL0690120	ERA20	1:5	30000	15Nm	X	CHUB36	CHUB22

MT RENT

MT CUT T25Y/SY - MT CUT T32Y/SY

MODULO MOTORIZZATO RADIALE MOLTIPLICATO I=1:5

Radial geared-up I=1:5 driven tool

Radial angetriebenes Werkzeug uebersetzt I=1:5

Subject to change without notice.

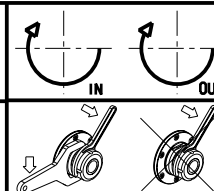

**M.T. srl**

Via Casino Albini 480  
Tel. 0541/956034-957884  
Fax 0541/956341  
47842 S. GIOVANNI IN M. (RN)  
e-mail: mtma@mtmarchetti.com  
http://www.mtmarchetti.com

PRODUZIONE MODULI ROTANTI



PAGINA MTR059-1-00

## ATTENZIONE - ATTENTION - ACHTUNG

- Per lo smontaggio degli utensili utilizzare sempre la chiave di contrasto come indicato nel manuale d'uso.
- For disassembly of the tools use always the contrast key as mentioned in the user instructions.
- Fuer das Abmontieren der Werkzeuge immer den Gegenschlüssel benutzen wie in der Bedienungsanleitung erwaeht.

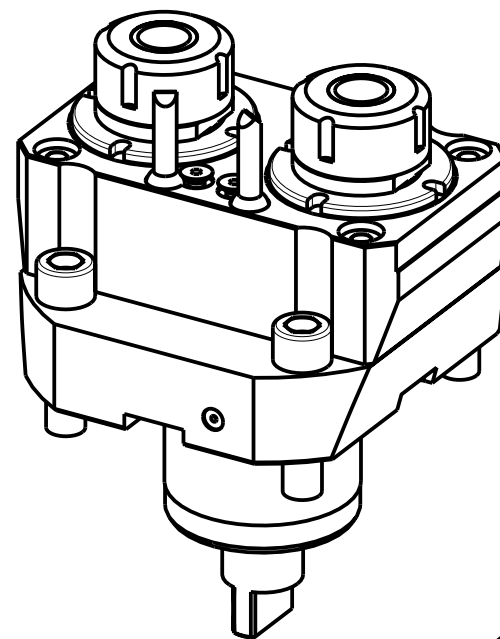
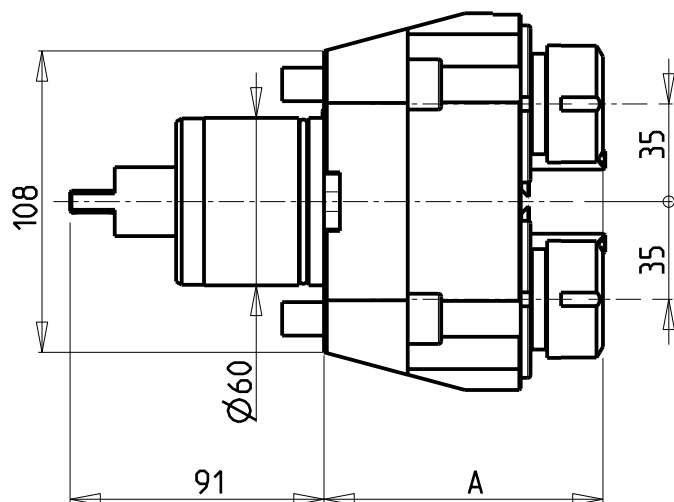
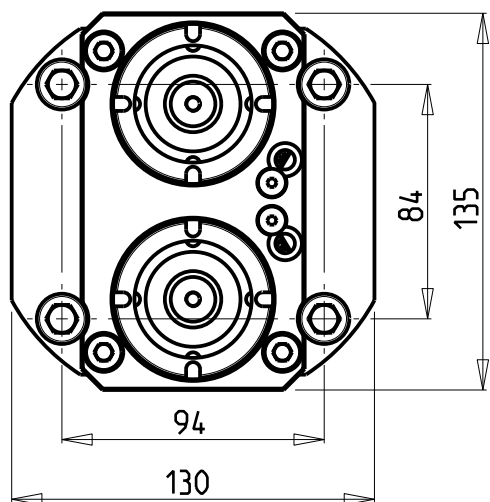

MNL0201325

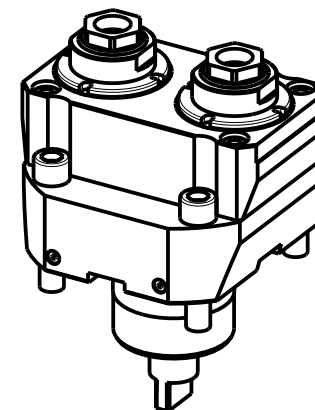

Cod. MT	Mandrino Spindle Spindel	I	RPM	Coppia Max Max Torque Max Drehmoment	Lubrificazione int. Coolant through Innenkuehlung	Lubrificazione est. Ext. coolant Aussenkuehlung	A	CHIAVI NON INCLUSE Keys not included Schlüssel nicht einbegriffen	
MNL0200225	ER25	1:1	6000	40Nm		X	99.96	CHUB36	CHSTER25
MNL0201225	ER25	1:1	6000	40Nm	P=70bar	X	115.2	CHUB36	CHSTER25
MNL0201325	ER A 25	1:1	6000	40Nm	P=70bar	X	108.53	CHUB38	CHUB27

MT RENT

MT CUT T25Y/SY - MT CUT T32Y/SY

MODULO MOTORIZZATO RADIALE 2 USCITE IN Y

Radial single side twin head driven tool in Y

Radial angetriebenes Werkzeug 2 Ausgaenge in Y

Subject to change without notice.

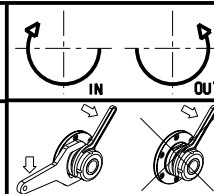

**M.T. srl**

Via Casino Albini 480  
Tel. 0541/956034-957884  
Fax 0541/956341

47842 S. GIOVANNI IN M. (RN)  
e-mail: mtma@mtmarchetti.com  
http://www.mtmarchetti.com

PRODUZIONE MODULI ROTANTI



PAGINA MTR080-1-00

## ATTENZIONE - ATTENTION - ACHTUNG

- Per lo smontaggio degli utensili utilizzare sempre la chiave di contrasto come indicato nel manuale d'uso.
- For disassembly of the tools use always the contrast key as mentioned in the user instructions.
- Fuer das Abmontieren der Werkzeuge immer den Gegenschlüssel benutzen wie in der Bedienungsanleitung erwaeht.

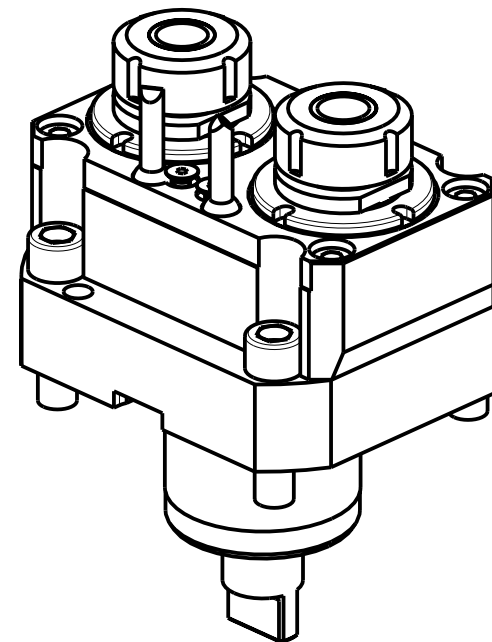
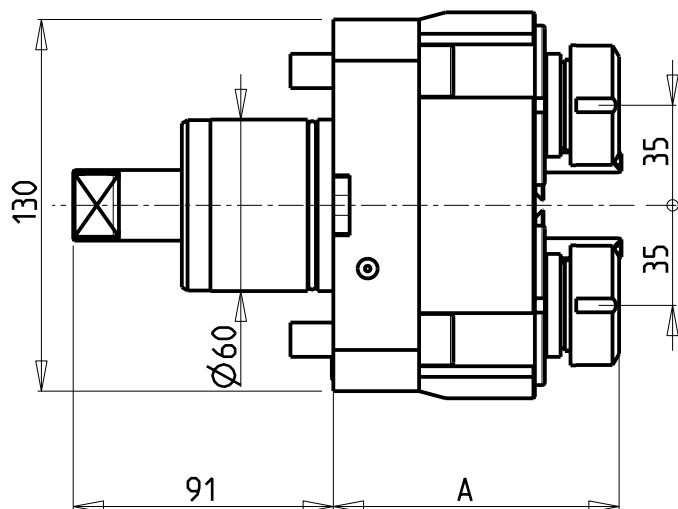
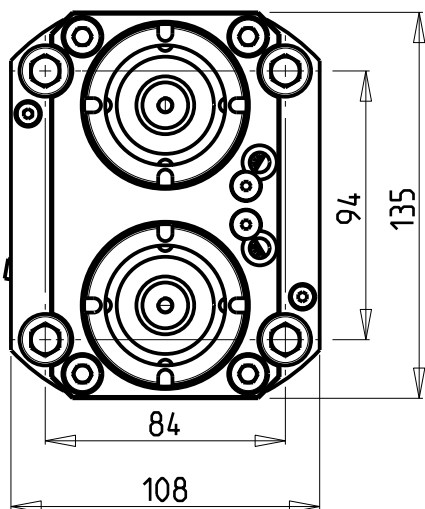

MNL0421325

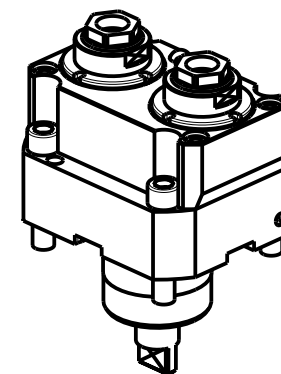

Cod. MT	Mandrino Spindle Spindel	I	RPM	Coppia Max Max Torque Max Drehmoment	Lubrificazione int. Coolant through Innenkuehlung	Lubrificazione est. Ext. coolant Aussenkuehlung	A	CHIAVI NON INCLUSE Keys not included Schluesssel nicht einbegriffen	
MNL0420225	ER25	1:1	6000	40Nm		X	99.96	CHUB36	CHSTER25
MNL0421225	ER25	1:1	6000	40Nm	P=70bar	X	115.2	CHUB36	CHSTER25
MNL0421325	ER A 25	1:1	6000	40Nm	P=70bar	X	108.53	CHUB38	CHUB27

MT RENT

MT CUT T25Y/SY - MT CUT T32Y/SY

MODULO MOTORIZZATO RADIALE 2 USCITE IN Z  
Radial single side twin head driven tool in Z  
Radial angetriebenes Werkzeug 2 Ausgaenge in Z

Subject to change without notice.

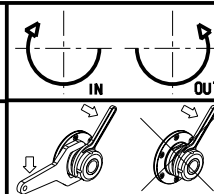

**M.T. srl**

Via Casino Albini 480  
Tel. 0541/956034-957884  
Fax 0541/956341  
47842 S. GIOVANNI IN M. (RN)  
e-mail: mtma@mtmarchetti.com  
http://www.mtmarchetti.com

PRODUZIONE MODULI ROTANTI



PAGINA MTR090-1-00

**ATTENZIONE - ATTENTION - ACHTUNG**

- Per lo smontaggio degli utensili utilizzare sempre la chiave di contrasto come indicato nel manuale d'uso.
- For disassembly of the tools use always the contrast key as mentioned in the user instructions.
- Fuer das Abmontieren der Werkzeuge immer den Gegenschlüssel benutzen wie in der Bedienungsanleitung erwaehnt.

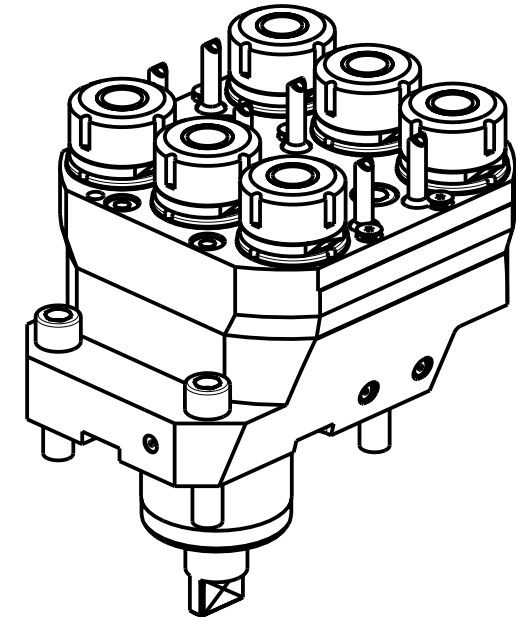
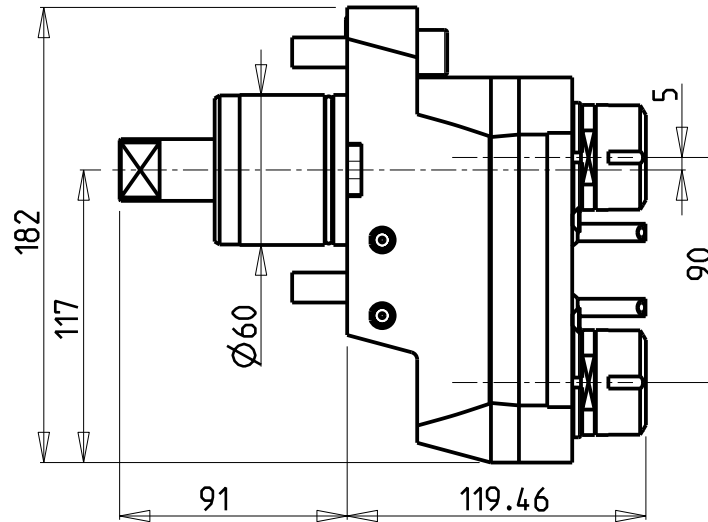
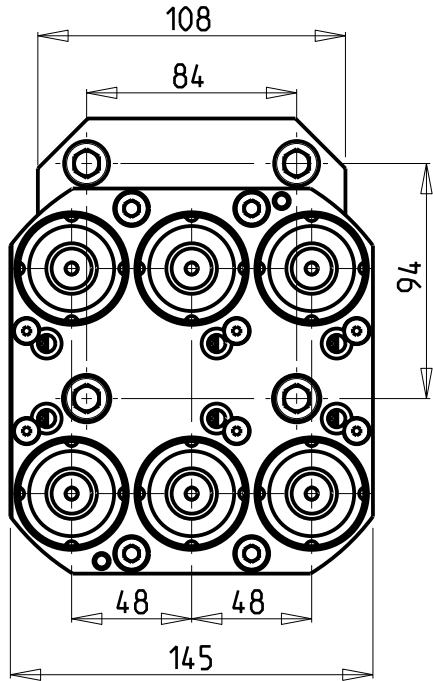

Cod. MT	Mandrino Spindle Spindel	I	RPM	Coppia Max Max Torque Max Drehmoment	N°Utensili N°Tools N°Werkzeuge	Reversibile lato mandrino/contromandrino Reversible sub/main spindle side Umkehrbare Spindel-seite/ Gegenspindel-seite	Lubrificazione est. Ext. coolant Aussenkuehlung	CHIAVI INCLUSE Keys included Schluesssel inbegriffen
MNL0210625	ER25	1:1	6000	20Nm	6	X	X	MNL0210007 MNL0210008

MT RENT  
MT CUT T25Y/SY - MT CUT T32Y/SY

MODULO MOTORIZZATO RADIALE 6 USCITE  
Radial 6 head driven tool  
Radial angetriebenes Werkzeug 6 Ausgaenge

Subject to change without notice.

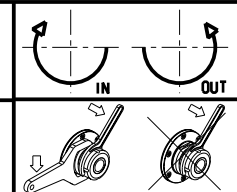

**M.T. srl**  
Via Casino Albini 480  
Tel. 0541/956034-957884  
Fax 0541/956341  
47842 S. GIOVANNI IN M. (RN)  
e-mail: mtma@mtmarchetti.com  
http://www.mtmarchetti.com

PRODUZIONE MODULI ROTANTI



PAGINA MTR110-1-00

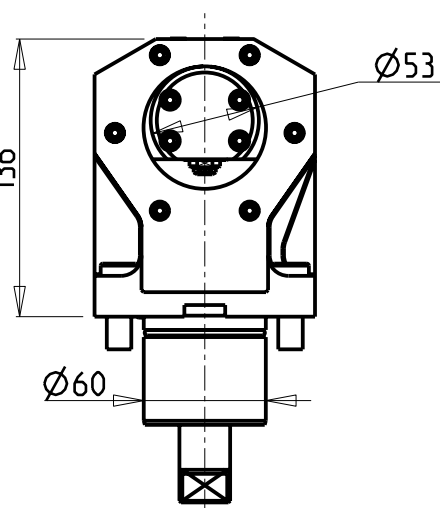
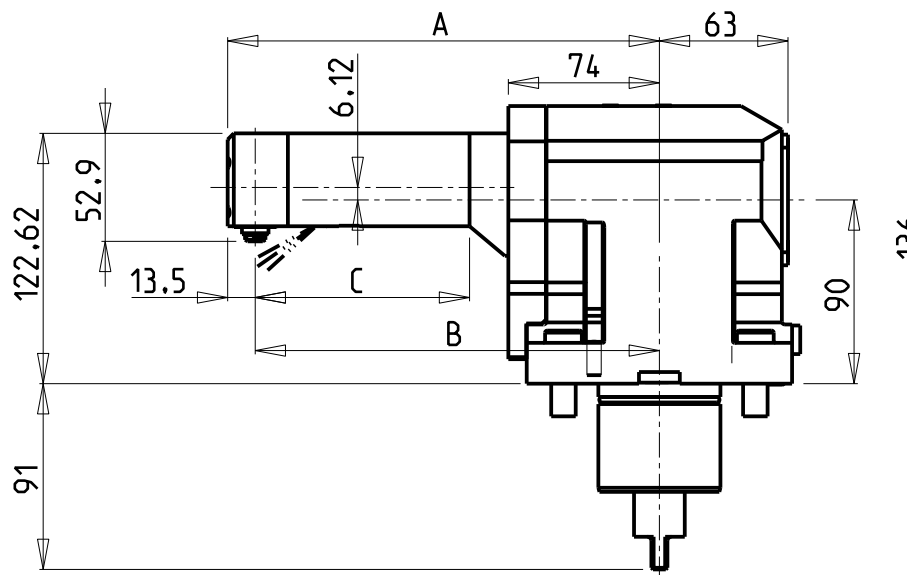
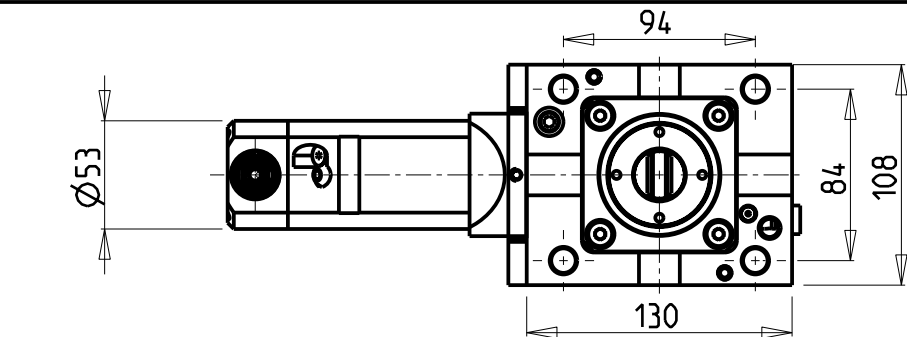

PER LAVORAZIONI INTERNE  
SU FORI Ø60 MINIMO

For machining internal  
holes with Ø60 min. hole

Fuer interne Bearbeitungen  
am loch minimum Ø60

**ATTENZIONE - ATTENTION - ACHTUNG**

- Per lo smontaggio degli utensili utilizzare sempre la chiave di contrasto come indicato nel manuale d'uso.
- For disassembly of the tools use always the contrast key as mentioned in the user instructions.
- Fuer das Abmontieren der Werkzeuge immer den Gegenschlüssel benutzen wie in der Bedienungsanleitung erwäehnt.

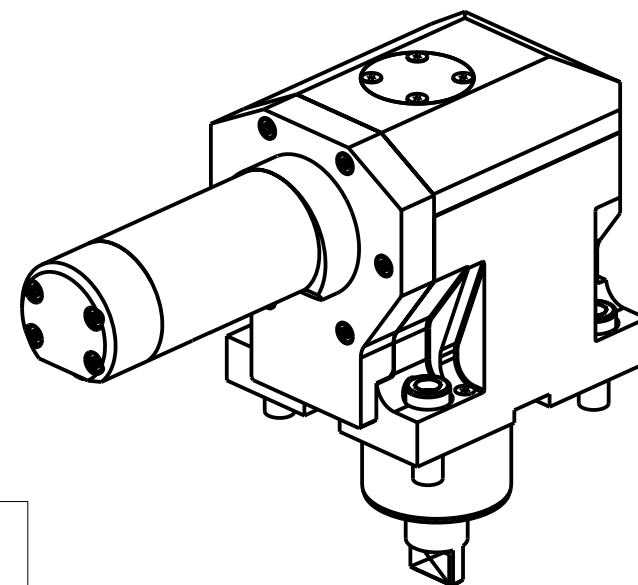

Cod. MT	Mandrino Spindle Spindel	I	RPM	Coppia Max Max Torque Max Drehmoment	Lubrificazione est. Ext. coolant Aussenkuehlung	A	B	C	CHIAVI INCLUSE Keys included Schluessel einbegriffen	
MNL0961055	CHG	1:1	6000	8Nm	X	161.5	148	55	CHUB13	CHCHG10
MNL0961105	CHG	1:1	6000	8Nm	X	211.5	198	105	CHUB13	CHCHG10
MNL0961155	CHG	1:1	6000	8Nm	X	261.5	248	155	CHUB13	CHCHG10

MT RENT

MT CUT T25Y/SY - MT CUT T32Y/SY

MODULO MOTORIZZATO RADIALE ROVESCiato DISASSATO IN Z

Radial inverted driven tool re-directed in Z

Radial angetriebenes Werkzeug ungekehrt achsversetzt in Z

Subject to change without notice.

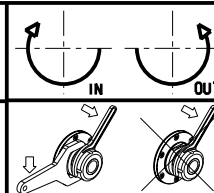

**M.T. srl**

Via Casino Albini 480  
Tel. 0541/956034-957884  
Fax 0541/956341

47842 S. GIOVANNI IN M. (RN)  
e-mail: mtma@mtmarchetti.com  
http://www.mtmarchetti.com

PRODUZIONE MODULI ROTANTI



PAGINA MTR120-1-30

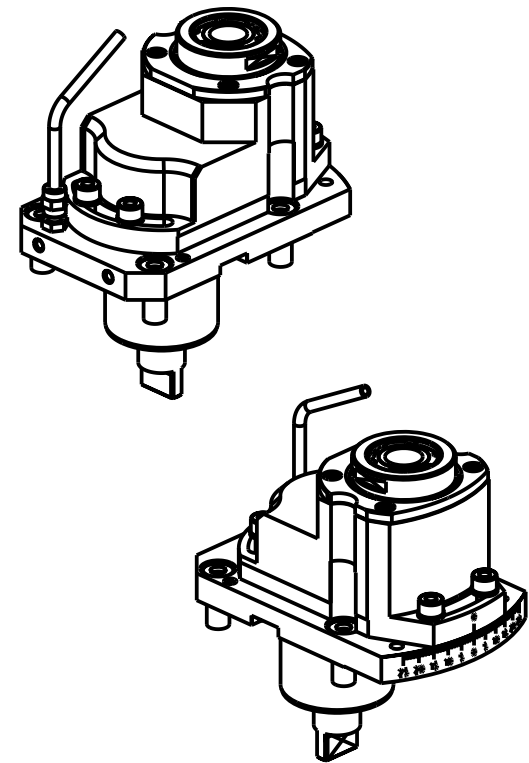
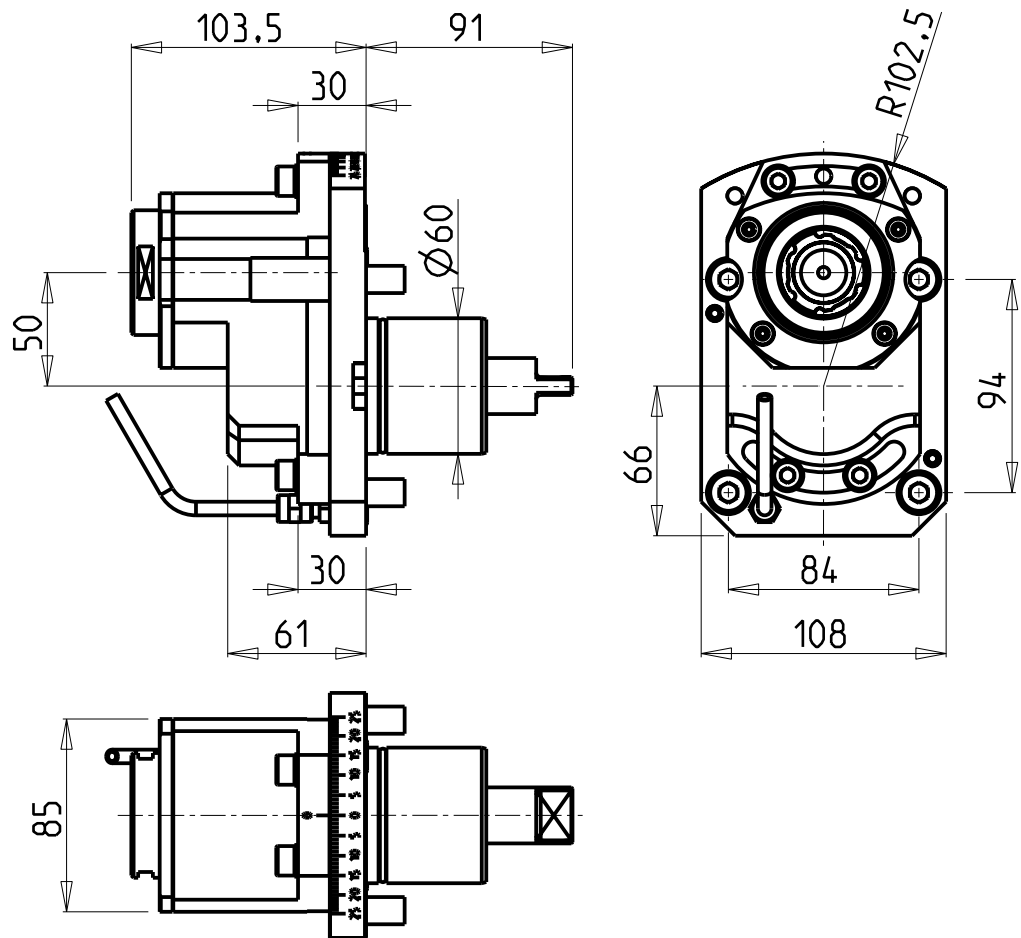

**ATTENZIONE - ATTENTION - ACHTUNG**

- Per lo smontaggio degli utensili utilizzare sempre la chiave di contrasto come indicato nel manuale d'uso.
- For disassembly of the tools use always the contrast key as mentioned in the user instructions.
- Fuer das Abmontieren der Werkzeuge immer den Gegenschlüssel benutzen wie in der Bedienungsanleitung erwaeht.

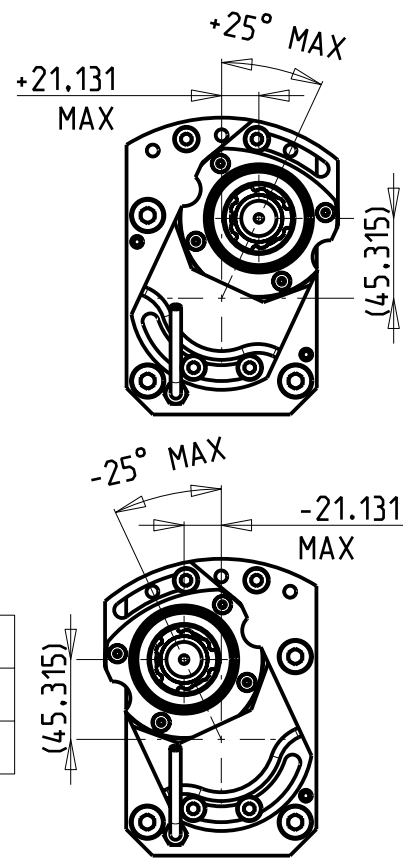

- Chiave inclusa
- Key included
- Schlüssel inbegriffen

Cod. MT	Mandrino Spindle Spindel	I	RPM	Coppia Max Max Torque Max Drehmoment	Reversibile lato mandrino/contromandrino Reversible sub/main spindle side Umkehrbare Spindelseite/ Gegenspindelseite	Lubrificazione est. Ext. coolant Aussenkuehlung	CHIAVI NON INCLUSE Keys not included Schluessel nicht einbegriffen		
MNL0950332	ERA32	1:1	6000	100Nm	X	X	CHUB30	CHUB50	CHTAER32ZC *

MT RENT  
 MT CUT T25Y/SY - MT CUT T32Y/SY

MODULO MOTORIZZATO RADIALE DISASSATO 50mm ORIENTABILE ±25°  
 Radial ±25° adjustable angle driven tool re-directed by 50mm  
 Radial angetriebenes Werkzeug schwenkbar ±25° achsversetzt um 50mm

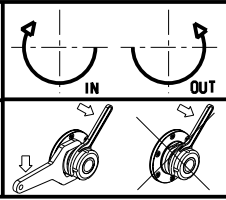

**M.T. srl**  
 Via Casino Albini 480  
 Tel. 0541/956034-957884  
 Fax 0541/956341  
 47842 S. GIOVANNI IN M. (RN)  
 e-mail: mtma@mtmarchetti.com  
 http://www.mtmarchetti.com

PRODUZIONE MODULI ROTANTI  
  
 PAGINA MTR135-1-00

Subject to change without notice.

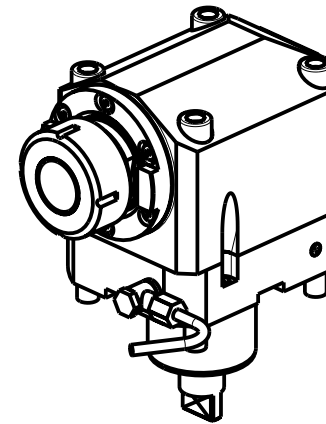
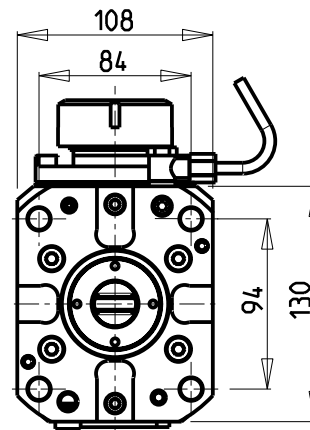
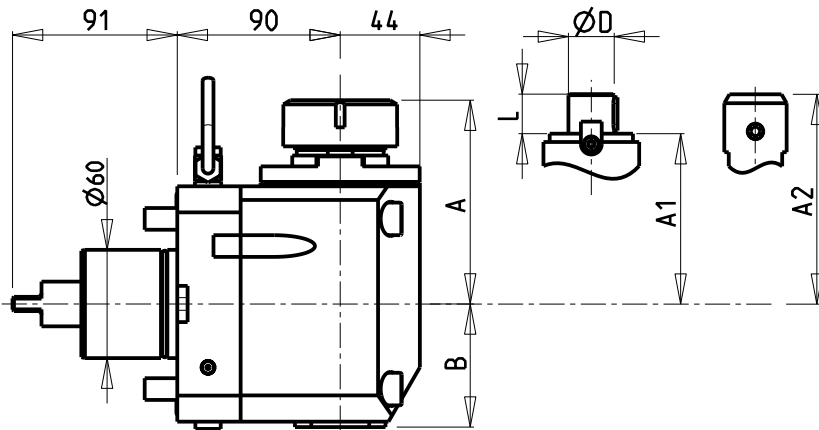

- Chiave inclusa
- Key included
- Schluessel inbegriffen

Cod. MT	Cod. MORI-SEIKI	Mandrino Spindle Spindel	I	RPM	Coppia Max Max Torque Max Drehmoment	Reversibile lato mandrino/contromandrino Reversible sub/main spindle side Umkehrbare Spindel-seite/ Gegenspindel-seite	Lubr.interna Coolant through Innenkuehlung	Lubr.esterna Ext. coolant Aussenkuehlung	A	A1	A2	B	D	L	CHIAVI NON INCLUDE Keys not included Schluessel nicht einbegriffen	
MNL0010525	-	ER25	1:1	6000	100Nm	X	-	X	107.6	-	-	69	-	-	OKU0650004	CHSTER25
MNL0010532	T32207	ER32	1:1	6000	100Nm	X	-	X	110.6	-	-	69	-	-	OKU0650004	CHSTER32
MNL0010140	T32214	ER40	1:1	6000	100Nm	X	-	X	112.6	-	-	69	-	-	OKU0650004	CHSTER40
MNL0010325	-	ER A 32	1:1	6000	100Nm	X	-	X	98.5	-	-	69	-	-	OKU0650004	CHUB32
MNL0011525	-	ER25	1:1	6000	100Nm	X	P=70bar	X	107.6	-	-	79	-	-	OKU0650004	CHSTER25
MNL0011532	-	ER32	1:1	6000	100Nm	X	P=70bar	X	110.6	-	-	79	-	-	OKU0650004	CHSTER32
MNL0011140	-	ER40	1:1	6000	100Nm	X	P=70bar	X	112.6	-	-	79	-	-	OKU0650004	CHSTER40
MNL0010432	-	ER A 32	1:1	6000	100Nm	X	P=70bar	X	98.5	-	-	79	-	-	OKU0650004	CHUB32
MNL0011617	-	Ø16x17	1:1	6000	100Nm	X	-	X	-	87.5	-	69	16	17	OKU0650004	CH_VTCROCE_M08
MNL0012219	-	Ø22x19	1:1	6000	100Nm	X	-	X	-	87.5	-	69	22	19	OKU0650004	CH_VTCROCE_M10
MNL0012721	-	Ø27x21	1:1	6000	100Nm	X	-	X	-	87.5	-	69	27	21	OKU0650004	CH_VTCROCE_M12
MNL0012519	-	Ø1"x19	1:1	6000	100Nm	X	-	X	-	87.5	-	69	1"	19	OKU0650004	CH_VTCROCE_M12
MNL0010120	-	WELDON 20	1:1	6000	100Nm	X	-	X	-	-	105.5	69	-	-	-	-
MNL0010125	-	WELDON 25	1:1	6000	100Nm	X	-	X	-	-	115	69	-	-	-	-
MNL0010132	-	WELDON 32	1:1	6000	100Nm	X	-	X	-	-	131.5	69	-	-	-	-
MNL0010220	-	WELDON 20	1:1	6000	100Nm	X	P=70bar	X	-	-	105.5	91.5	-	-	-	-
MNL0010225	-	WELDON 25	1:1	6000	100Nm	X	P=70bar	X	-	-	115	91.5	-	-	-	-

MT RENT  
MT CUT T25Y/SY - MT CUT T32Y/SY

MODULO MOTORIZZATO ASSIALE  
Axial driven tool  
Axial angetriebenes Werkzeug

Subject to change without notice.

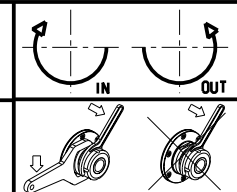

**M.T. srl**  
Via Casino Albini 480  
Tel. 0541/956034-957884  
Fax 0541/956341  
47842 S. GIOVANNI IN M. (RN)  
e-mail: mtma@tmarchetti.com  
http://www.tmmarchetti.com

PRODUZIONE MODULI ROTANTI



PAGINA MTR150-1-10



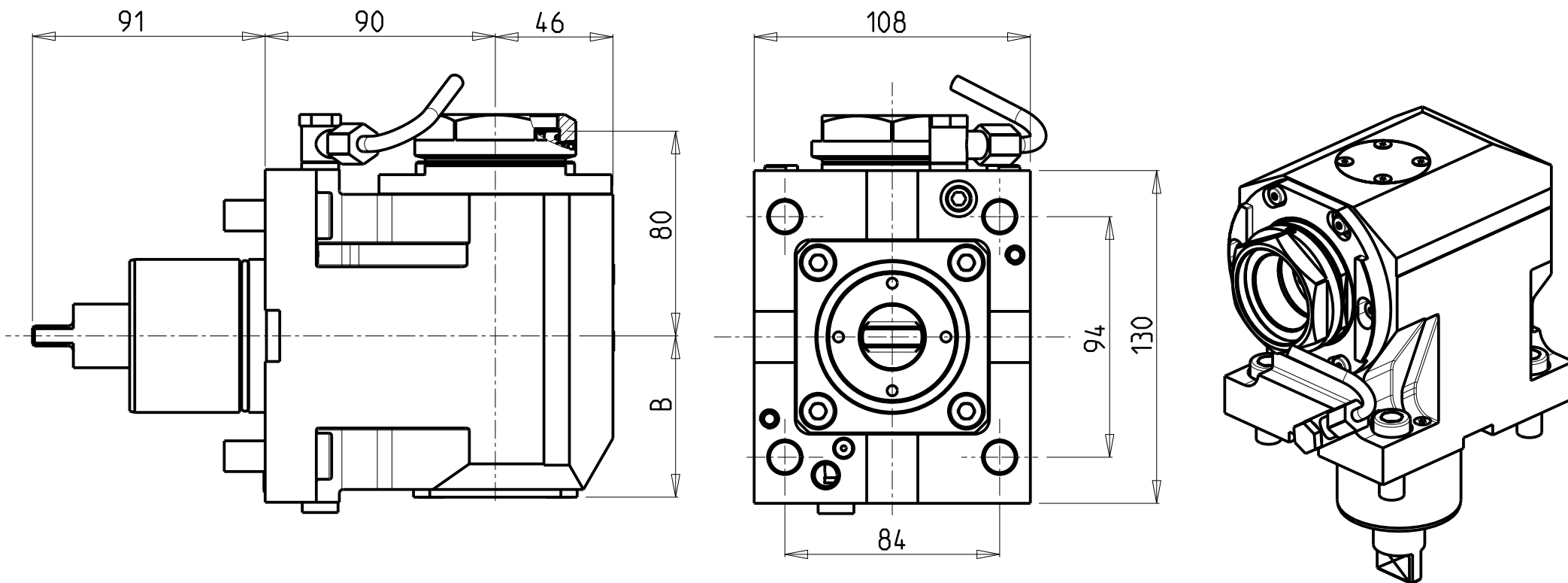

PER PORTAUTENSILI MODULARI MTSK-40 VEDI PAG. TBL300-1-40 E PER MTSK-50 VEDI PAG. TBL300-1-50  
 FOR MTSK-40 QUICK CHANGE TOOLHOLDERS CLAMPINGS SEE PAGE TBL300-1-40 AND FOR MTSK-50 SEE PAGE TBL300-1-50  
 FUER MTSK-40 MODULARE WERKZEUGAUFNAHMEN SIEHE SEITE TBL300-1-40 UND FUER MTSK-50 SIEHE SEITE TBL300-1-50

Cod. MT	Mandrino Spindle Spindel	I	RPM	Coppia Max Max Torque Max Drehmoment	Reversibile lato mandrino/contromandrino Reversible sub/main spindle side Umkehrbare Spindel-seite/ Gegenspindel-seite	Lubr.interna Coolant through Innenkuehlung	Lubr.esterna Ext. coolant Aussenkuehlung	B	CHIAVI NON INCLUSE Keys not included Schlüssel nicht einbegriffen	
MNL0580140	MTSK-40	1:1	6000	100Nm	X	-	X	63	CHUB46	OKU0430007 •
MNL0580240	MTSK-40	1:1	6000	100Nm	X	P=70bar	X	75.5	CHUB46	OKU0430007 •
MNL0580150	MTSK-50	1:1	6000	100Nm	X	-	X	63	CHUB55	OKU0430007 •
MNL0580250	MTSK-50	1:1	6000	100Nm	X	P=70bar	X	75.5	CHUB55	OKU0430007 •

- Chiave inclusa
- Key included
- Schlüssel inbegriffen

MT RENT  
 MT CUT T25Y/SY - MT CUT T32Y/SY

MODULO MOTORIZZATO ASSIALE MTSK  
 Axial MTSK driven tool  
 Axial MTSK angetriebenes Werkzeug

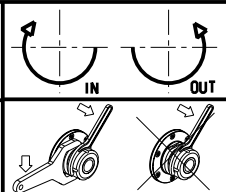

**M.T. srl**  
 Via Casino Albini 480  
 Tel. 0541/956034-957884  
 Fax 0541/956341  
 47842 S. GIOVANNI IN M. (RN)  
 e-mail: mtma@tmarchetti.com  
 http://www.tmmarchetti.com

PRODUZIONE MODULI ROTANTI



PAGINA MTR150-1-10-K

Subject to change without notice.

10/2018

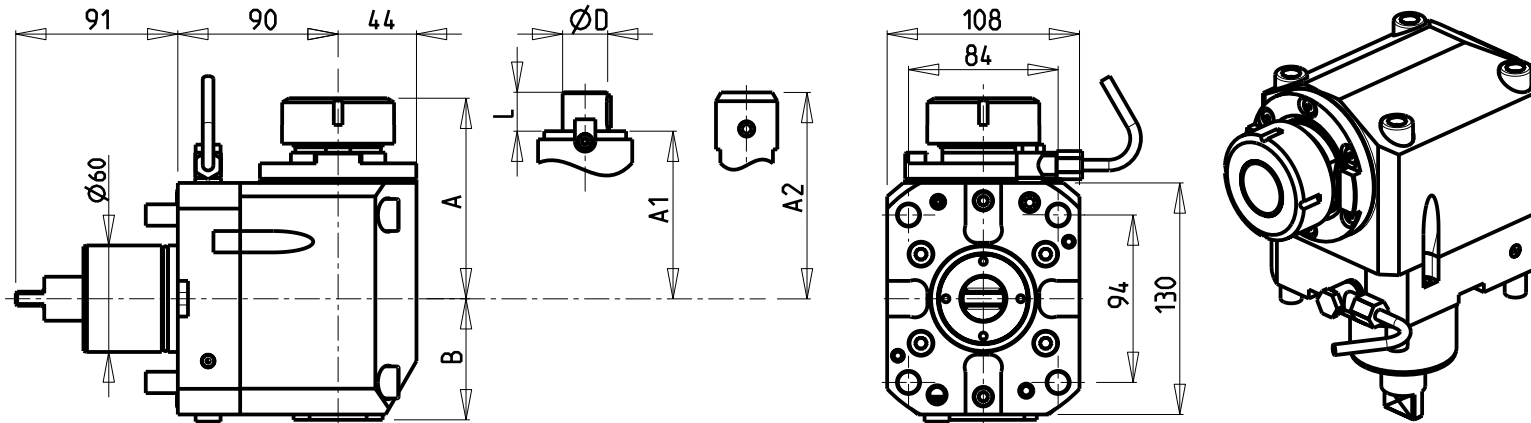

- Chiave inclusa
- Key included
- Schlüssel inbegriffen

Cod. MT	Mandrino Spindle Spindel	I	RPM	Coppia Max Max Torque Max Drehmoment	Reversibile lato mandrino/contromandrino Reversible sub/main spindle side Umkehrbare Spindel-seite/ Gegenspindel-seite	Lubr.interna Coolant through Innenkuehlung	Lubr.esterna Ext. coolant Aussenkuehlung	A	A1	A2	B	D	L	CHIAVI NON INCLUDE Keys not included Schlüssel nicht einbegriffen
MNL0750525	ER25	1:1	10000	100Nm	X	-	X	107.6	-	-	69	-	-	OKU0650004 ■ CHSTER25
MNL0750532	ER32	1:1	10000	100Nm	X	-	X	110.6	-	-	69	-	-	OKU0650004 ■ CHSTER32
MNL0750140	ER40	1:1	10000	100Nm	X	-	X	112.6	-	-	69	-	-	OKU0650004 ■ CHSTER40
MNL0750332	ER A 32	1:1	10000	100Nm	X	-	X	98.5	-	-	69	-	-	OKU0650004 ■ CHUB32
MNL0751525	ER25	1:1	10000	100Nm	X	P=70bar	X	107.6	-	-	79	-	-	OKU0650004 ■ CHSTER25
MNL0751532	ER32	1:1	10000	100Nm	X	P=70bar	X	110.6	-	-	79	-	-	OKU0650004 ■ CHSTER32
MNL0751140	ER40	1:1	10000	100Nm	X	P=70bar	X	112.6	-	-	79	-	-	OKU0650004 ■ CHSTER40
MNL0750432	ER A 32	1:1	10000	100Nm	X	P=70bar	X	98.5	-	-	79	-	-	OKU0650004 ■ CHUB32
MNL0751617	Ø16x17	1:1	10000	100Nm	X	-	X	-	87.5	-	69	16	17	OKU0650004 ■ CH_VTCROCE_M08 ■
MNL0752219	Ø22x19	1:1	10000	100Nm	X	-	X	-	87.5	-	69	22	19	OKU0650004 ■ CH_VTCROCE_M10 ■
MNL0752721	Ø27x21	1:1	10000	100Nm	X	-	X	-	87.5	-	69	27	21	OKU0650004 ■ CH_VTCROCE_M12 ■
MNL0752519	Ø1"x19	1:1	10000	100Nm	X	-	X	-	87.5	-	69	1"	19	OKU0650004 ■ CH_VTCROCE_M12 ■
MNL0750120	WELDON 20	1:1	10000	100Nm	X	-	X	-	-	105.5	69	-	-	-
MNL0750125	WELDON 25	1:1	10000	100Nm	X	-	X	-	-	115	69	-	-	-
MNL0750132	WELDON 32	1:1	10000	100Nm	X	-	X	-	-	131.5	69	-	-	-
MNL0750220	WELDON 20	1:1	10000	100Nm	X	P=70bar	X	-	-	105.5	91.5	-	-	-
MNL0750225	WELDON 25	1:1	10000	100Nm	X	P=70bar	X	-	-	115	91.5	-	-	-

MT RENT  
MT CUT T25Y/SY - MT CUT T32Y/SY

MODULO MOTORIZZATO ASSIALE 10000 RPM  
Axial driven tool 10000 rpm  
Axial angetriebenes Werkzeug 10000 rpm

Subject to change without notice.

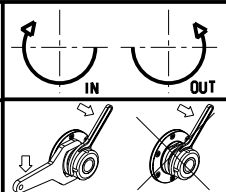

**M.T. srl**  
Via Casino Albini 480  
Tel. 0541/956034-957884  
Fax 0541/956341  
47842 S. GIOVANNI IN M. (RN)  
e-mail: mtma@tmarchetti.com  
http://www.tmmarchetti.com

PRODUZIONE MODULI ROTANTI



PAGINA MTR150-1-11

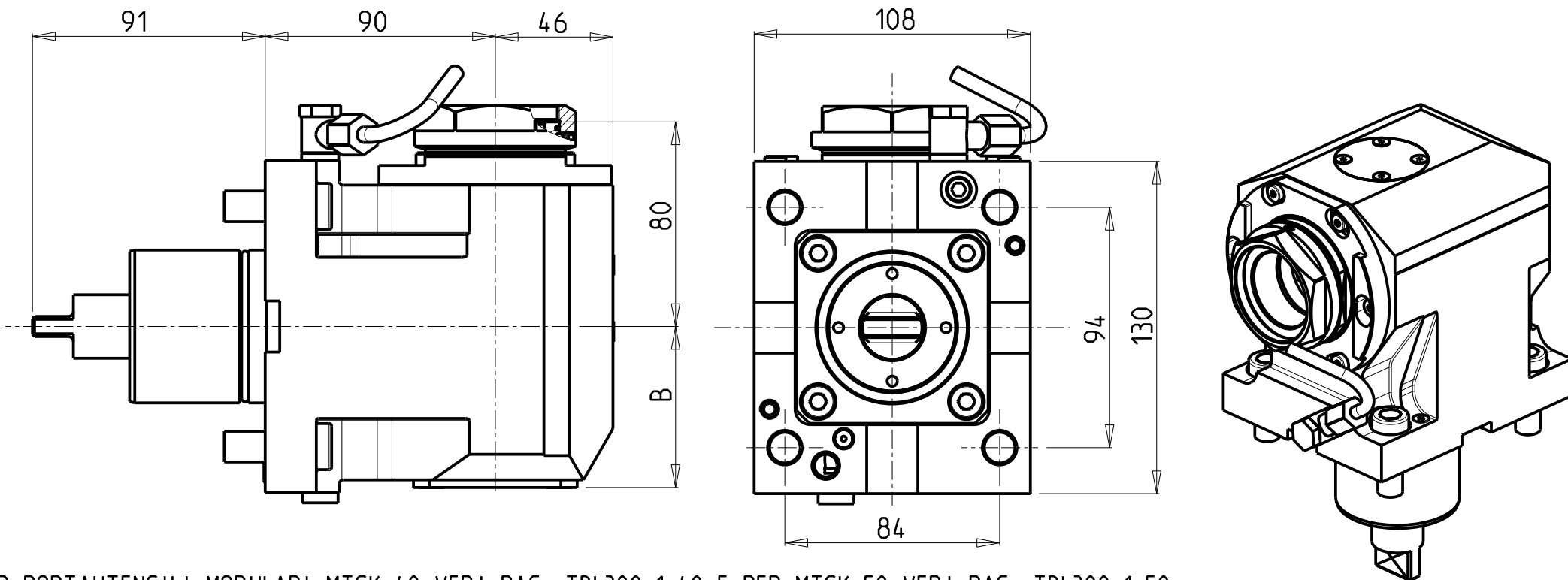

PER PORTAUTENSILI MODULARI MTSK-40 VEDI PAG. TBL300-1-40 E PER MTSK-50 VEDI PAG. TBL300-1-50  
 FOR MTSK-40 QUIK CHANGE TOOLHOLDERS CLAMPINGS SEE PAGE TBL300-1-40 AND FOR MTSK-50 SEE PAGE TBL300-1-50  
 FUER MTSK-40 MODULARE WERKZEUGAUFNAHMEN SIEHE SEITE TBL300-1-40 UND FUER MTSK-50 SIEHE SEITE TBL300-1-50

Cod. MT	Mandrino Spindel Spindel	I	RPM	Coppia Max Max Torque Max Drehmoment	Reversibile lato mandrino/contromandrino Reversible sub/main spindle side Umkehrbare Spindel-seite/Gegenspindel-seite	Lubr.interna Coolant through Innenkuehlung	Lubr.esterna Ext. coolant Aussenkuehlung	B	CHIAVI NON INCLUSE Keys not included Schluessel nicht einbegriffen	
MNL0780140	MTSK-40	1:1	10000	100Nm	X	-	X	63	CHUB46	OKU0430007
MNL0780240	MTSK-40	1:1	10000	100Nm	X	P=70bar	X	75.5	CHUB46	OKU0430007
MNL0780150	MTSK-50	1:1	10000	100Nm	X	-	X	63	CHUB55	OKU0430007
MNL0780250	MTSK-50	1:1	10000	100Nm	X	P=70bar	X	75.5	CHUB55	OKU0430007

- Chiave inclusa
- Key included
- Schluessel inbegriffen

MT RENT  
 MT CUT T25Y/SY - MT CUT T32Y/SY  
 MODULO MOTORIZZATO ASSIALE MTSK 10000 RPM  
 Axial MTSK driven tool 10000 rpm  
 Axial MTSK angetriebenes Werkzeug 10000 rpm

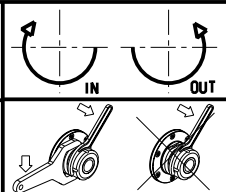

**M.T. srl**  
 Via Casino Albini 480  
 Tel. 0541/956034-957884  
 Fax 0541/956341  
 47842 S. GIOVANNI IN M. (RN)  
 e-mail: mtma@tmarchetti.com  
 http://www.tmmarchetti.com

PRODUZIONE MODULI ROTANTI  
  
 PAGINA MTR150-1-11-K

Subject to change without notice.

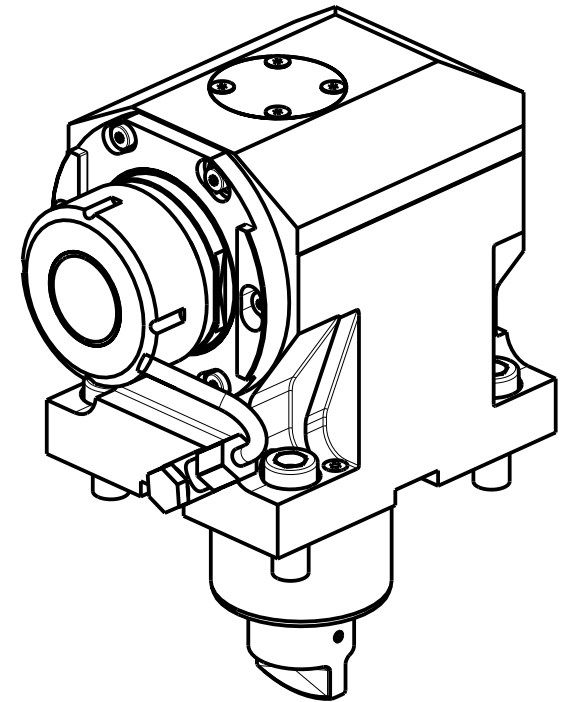
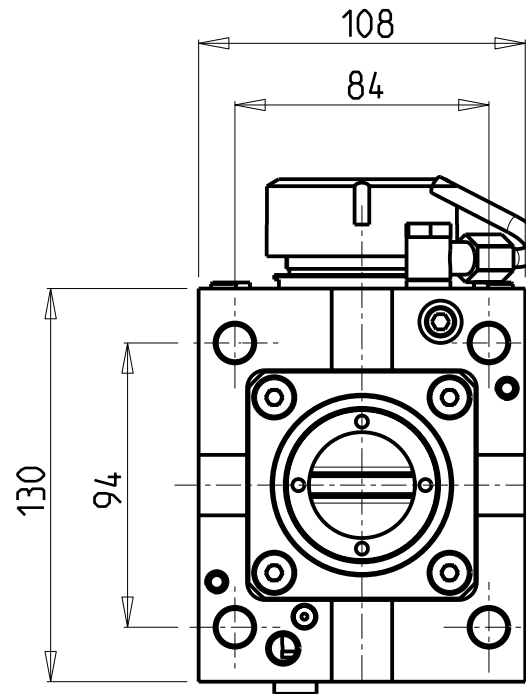
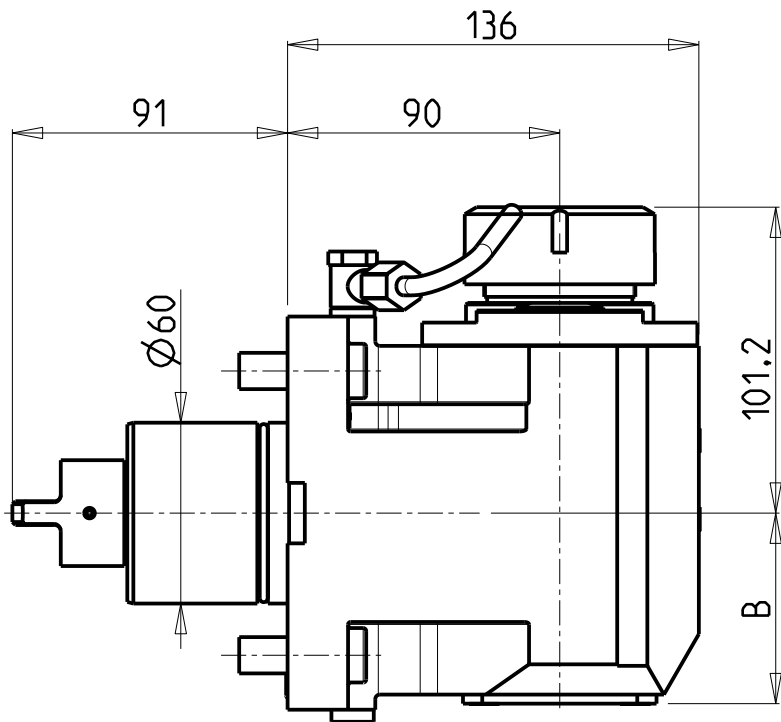

Cod. MT	Mandrino Spindle Spindel	I	RPM	Coppia Max Max Torque Max Drehmoment	Reversibile lato mandrino/contromandrino Reversible sub/main spindle side Umkehrbare Spindel-seite/ Gegenspindel-seite	Lubr.interna Coolant through Innenkuehlung	Lubr.esterna Ext. coolant Aussenkuehlung	B	CHIAVI NON INCLUSE Keys not included Schlüssel nicht einbegriffen	
MNL0840140	ER40	1:1	4000	100Nm	X	-	X	63	CHSTER40	OKU0430007 •
MNL0840240	ER40	1:1	4000	100Nm	X	P=70bar	X	75.5	CHSTER40	OKU0430007 •

- Chiave inclusa
- Key included
- Schlüssel einbegriffen

MT RENT  
MT CUT T25Y/SY - MT CUT T32Y/SY

MODULO MOTORIZZATO ASSIALE  
Axial driven tool  
Axial angetriebenes Werkzeug

Subject to change without notice.

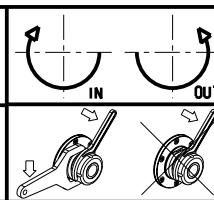

**M.T. srl**  
Via Casino Albini 480  
Tel. 0541/956034-957884  
Fax 0541/956341  
47842 S. GIOVANNI IN M. (RN)  
e-mail: mtma@tmarchetti.com  
http://www.tmmarchetti.com

PRODUZIONE MODULI ROTANTI



PAGINA MTR170-1-10

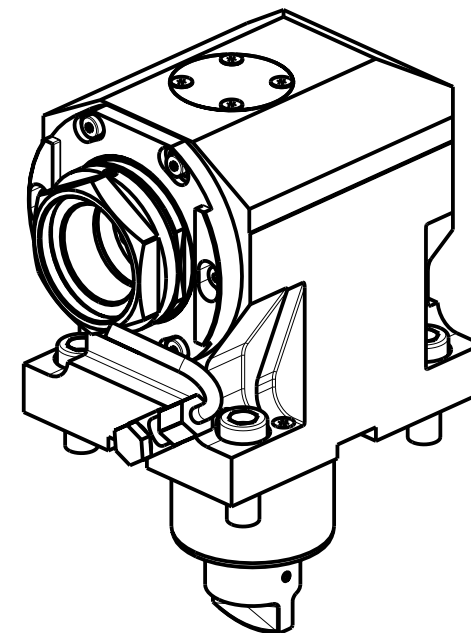
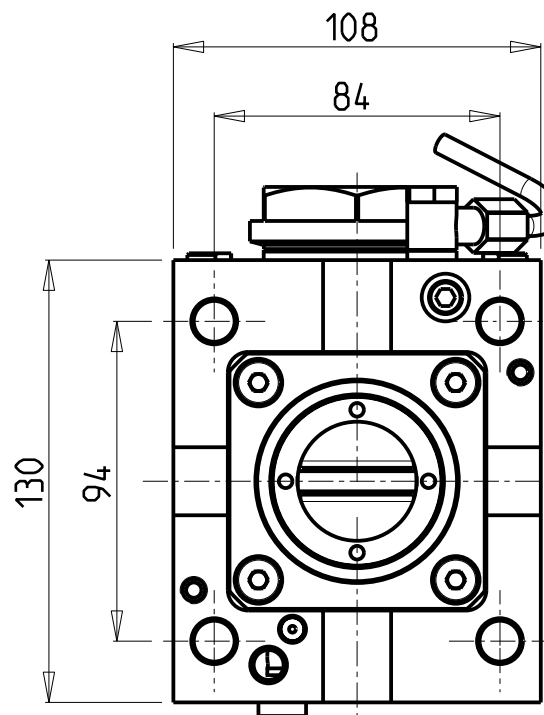
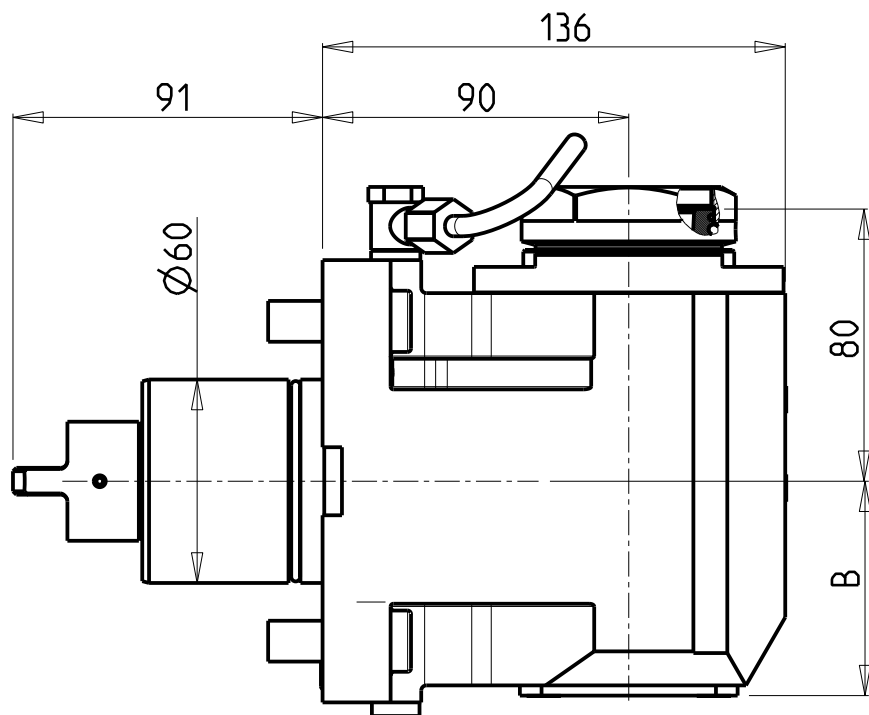

PER PORTAUTENSILI MODULARI MTSK-40 VEDI PAG. TBL300-1-40 E PER MTSK-50 VEDI PAG. TBL300-1-50  
 FOR MTSK-40 QUIK CHANGE TOOLHOLDERS CLAMPINGS SEE PAGE TBL300-1-40 AND FOR MTSK-50 SEE PAGE TBL300-1-50  
 FUER MTSK-40 MODULARE WERKZEUGAUFNAHMEN SIEHE SEITE TBL300-1-40 UND FUER MTSK-50 SIEHE SEITE TBL300-1-50

Cod. MT	Mandrino Spindle Spindel	I	RPM	Coppia Max Max Torque Max Drehmoment	Reversibile lato mandrino/contromandrino Reversible sub/main spindle side Umkehrbare Spindel-seite/ Gegenspindel-seite	Lubr.interna Coolant through Innenkuehlung	Lubr.esterna Ext. coolant Aussenkuehlung	B	CHIAVI NON INCLUSE Keys not included Schluessel nicht einbegriffen	
MNL0850140	MTSK-40	1:1	4000	100Nm	X	-	X	63	CHUB46	OKU0430007 *
MNL0850240	MTSK-40	1:1	4000	100Nm	X	P=70bar	X	75.5	CHUB46	OKU0430007 *
MNL0850150	MTSK-50	1:1	4000	100Nm	X	-	X	63	CHUB55	OKU0430007 *
MNL0850250	MTSK-50	1:1	4000	100Nm	X	P=70bar	X	75.5	CHUB55	OKU0430007 *

- Chiave inclusa
- Key included
- Schluessel inbegriffen

MT RENT  
 MT CUT T25Y/SY - MT CUT T32Y/SY

MODULO MOTORIZZATO ASSIALE MTSK  
 Axial MTSK driven tool  
 Axial MTSK angetriebenes Werkzeug

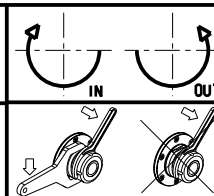

**M.T. srl**  
 Via Casino Albini 480  
 Tel. 0541/956034-957884  
 Fax 0541/956341  
 47842 S. GIOVANNI IN M. (RN)  
 e-mail: mtma@tmarchetti.com  
 http://www.tmarchetti.com

PRODUZIONE MODULI ROTANTI



PAGINA MTR170-1-10-K

Subject to change without notice.

10/2018

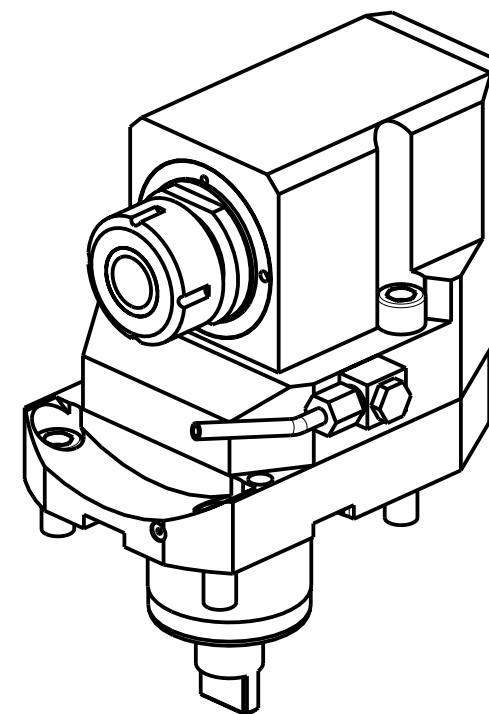
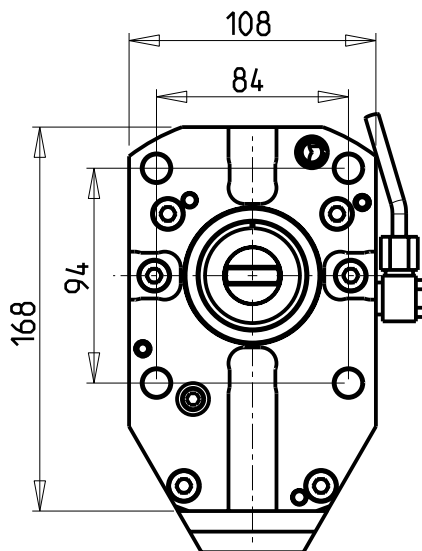
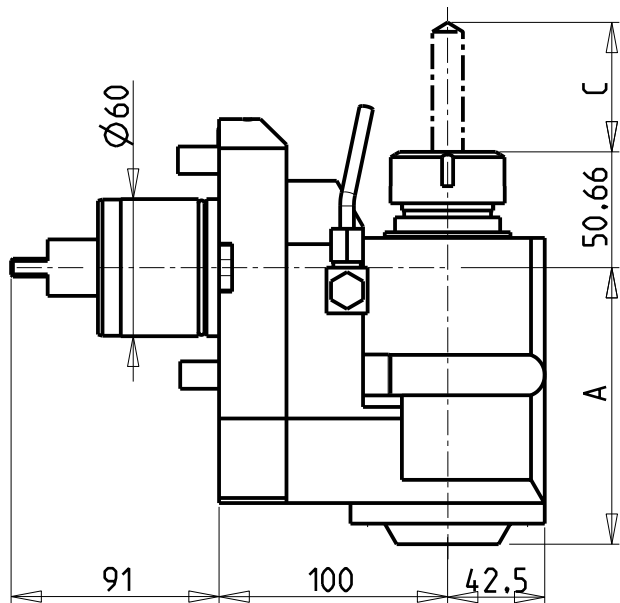
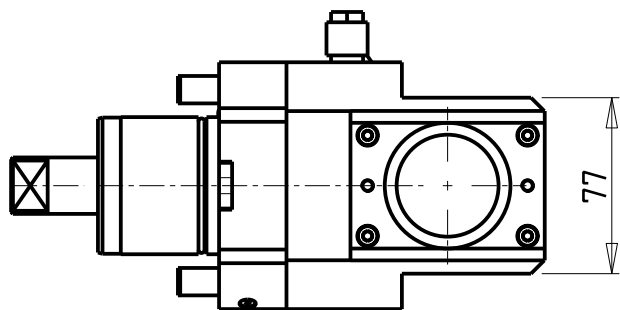

Cod. MT	Mandrino Spindle Spindel	I	RPM	Coppia Max Max Torque Max Drehmoment	Reversibile lato mandrino/contromandrino Reversible sub/main spindle side Umkehrbare Spindel-seite/ Gegenspindel-seite	Lubrificazione int. Coolant through Innenkuehlung	Lubrificazione est. Ext. coolant Aussenkuehlung	A	C max	CHIAVI NON INCLUSE Keys not included Schlüssel nicht einbegriffen
MNL0290632	ER32	1:1	6000	100Nm	X		X	121	118	CHUB46 CHSTER32
MNL0291632	ER32	1:1	6000	100Nm	X	P=70bar	X	135	118	CHUB46 CHSTER32

MT RENT  
MT CUT T25Y/SY - MT CUT T32Y/SY

MODULO MOTORIZZATO ASSIALE ARRETRATO  
Axial rear-set driven tool  
Axial angetriebenes Werkzeug zurueckversetzt

Subject to change without notice.

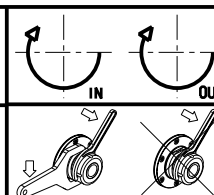

**M.T. srl**  
Via Casino Albini 480  
Tel. 0541/956034-957884  
Fax 0541/956341  
47842 S. GIOVANNI IN M. (RN)  
e-mail: mtma@mtmarchetti.com  
http://www.mtmarchetti.com

PRODUZIONE MODULI ROTANTI



PAGINA MTR180-1-10

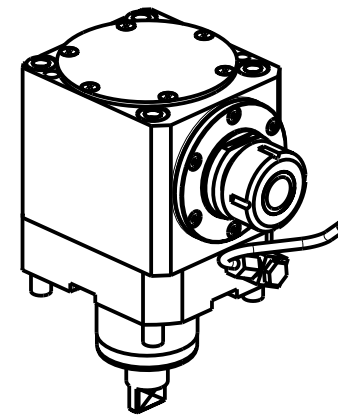
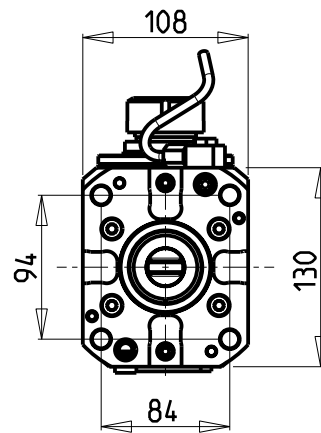
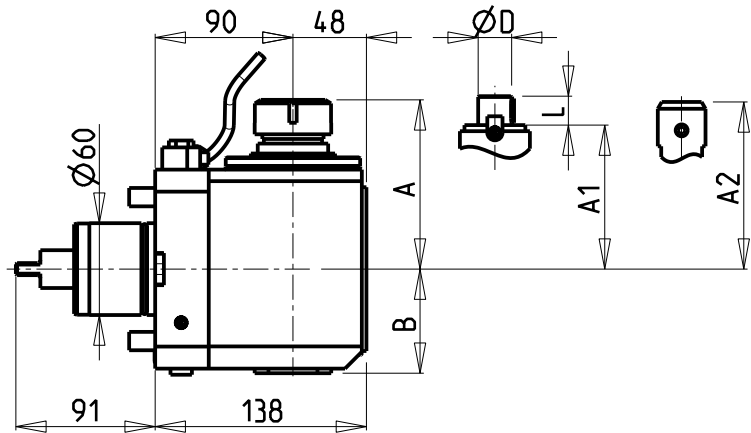

- Chiave inclusa
- Key included
- Schluessel inbegriffen

Cod. MT	Mandrino Spindel Spindel	I	RPM	Coppia Max Max Torque Max Drehmoment	Reversibile lato mandrino/contromandrino Reversible sub/main spindle side Umkehrbare Spindel-seite/ Gegenspindel-seite	Lubrificazione int. Coolant through Innenkühlung	Lubrificazione est. Ext. coolant Aussenkühlung	A	A1	A2	B	D	L	CHIAVI NON INCLUDE Keys not included Schluessel nicht einbegriffen	
MNL0330525	ER25	2:1	3000	100Nm	X	-	X	107.5	-	-	68	-	-	OKU0650004	CHSTER25
MNL0331525	ER25	2:1	3000	100Nm	X	P=70bar	X	107.5	-	-	79	-	-	OKU0650004	CHSTER25
MNL0330532	ER32	2:1	3000	100Nm	X	-	X	110.56	-	-	68	-	-	OKU0650004	CHSTER32
MNL0331532	ER32	2:1	3000	100Nm	X	P=70bar	X	110.56	-	-	79	-	-	OKU0650004	CHSTER32
MNL0330140	ER40	2:1	3000	100Nm	X	-	X	113.16	-	-	68	-	-	OKU0650004	CHSTER40
MNL0331140	ER40	2:1	3000	100Nm	X	P=70bar	X	113.16	-	-	79	-	-	OKU0650004	CHSTER40
MNL0331617	Ø16X17	2:1	3000	100Nm	X	-	X	-	87.5	-	68	16	17	CHUB46	CH_VTCROCE_M08
MNL0332219	Ø22X19	2:1	3000	100Nm	X	-	X	-	87.5	-	68	22	19	CHUB46	CH_VTCROCE_M10
MNL0332721	Ø27x21	2:1	3000	100Nm	X	-	X	-	87.5	-	68	27	21	CHUB46	CH_VTCROCE_M12
MNL0332519	Ø1''X19	2:1	3000	100Nm	X	-	X	-	87.5	-	68	1"	19	CHUB46	CH_VTCROCE_M12
MNL0330120	WELDON 20	2:1	3000	100Nm	X	-	X	-	-	105.5	68	-	-	-	-
MNL0330220	WELDON 20	2:1	3000	100Nm	X	P=70bar	X	-	-	105.5	91.5	-	-	-	-
MNL0330125	WELDON 25	2:1	3000	100Nm	X	-	X	-	-	115	68	-	-	-	-
MNL0330225	WELDON 25	2:1	3000	100Nm	X	P=70bar	X	-	-	115	91.5	-	-	-	-
MNL0330132	WELDON 32	2:1	3000	100Nm	X	-	X	-	-	131.5	68	-	-	-	-
MNL0330232	WELDON 32	2:1	3000	100Nm	X	P=70bar	X	-	-	131.5	91.5	-	-	-	-

MT RENT  
MT CUT T25Y/SY - MT CUT T32Y/SY

MODULO MOTORIZZATO ASSIALE RIDOTTO I=2:1  
Axial geared-down I=2:1 driven tool  
Axial angetriebenes Werkzeug untersetzt I=2:1

Subject to change without notice.

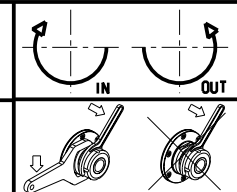

**M.T. srl**  
Via Casino Albini 480  
Tel. 0541/956034-957884  
Fax 0541/956341  
47842 S. GIOVANNI IN M. (RN)  
e-mail: mtma@tmarchetti.com  
http://www.tmmarchetti.com

PRODUZIONE MODULI ROTANTI



PAGINA MTR190-1-10

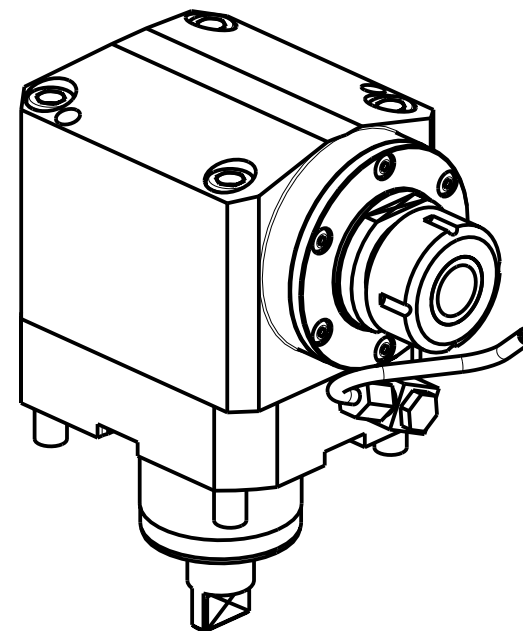
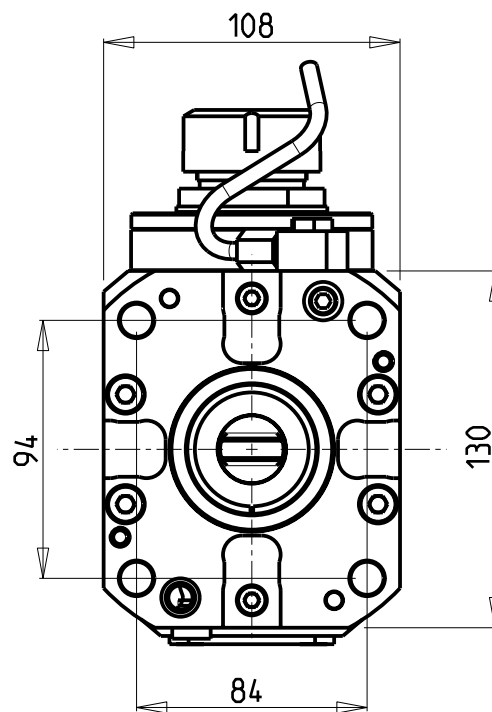
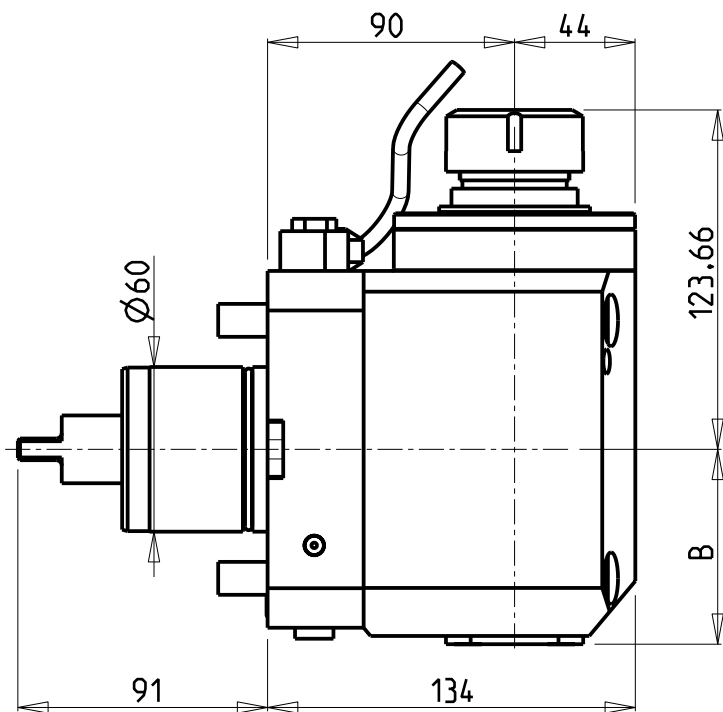

Cod. MT	Mandrino Spindle Spindel	I	RPM	Coppia Max Max Torque Max Drehmoment	Reversibile lato mandrino/contromandrino Reversible sub/main spindle side Umkehrbare Spindel-seite/ Gegenspindel-seite	Lubrificazione int. Coolant through Innenkühlung	Lubrificazione est. Ext. coolant Aussenkühlung	B	CHIAVI NON INCLUSE Keys not included Schlüssel nicht einbegriffen	
MNL0350532	ER32	1:2	12000	50Nm	X		X	71	CHUB46	CHSTER32
MNL0351532	ER32	1:2	12000	50Nm	X	P=70bar	X	94.5	CHUB46	CHSTER32

MT RENT  
MT CUT T25Y/SY - MT CUT T32Y/SY

MODULO MOTORIZZATO ASSIALE MOLTIPLICATO I=1:2  
Axial geared-up I=1:2 driven tool  
Axial angetriebenes Werkzeug uebersetzt I=1:2

Subject to change without notice.

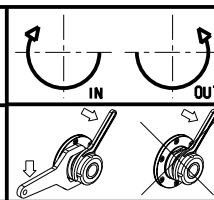

**M.T. srl**  
Via Casino Albini 480  
Tel. 0541/956034-957884  
Fax 0541/956341  
47842 S. GIOVANNI IN M. (RN)  
e-mail: mtma@mtmarchetti.com  
http://www.mtmarchetti.com

PRODUZIONE MODULI ROTANTI



PAGINA MTR200-1-10



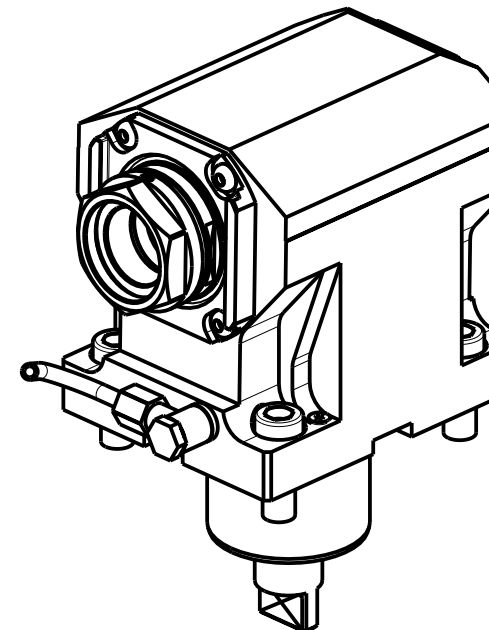
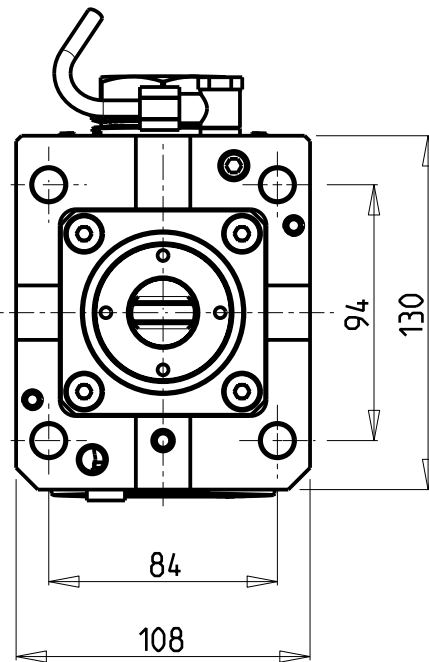
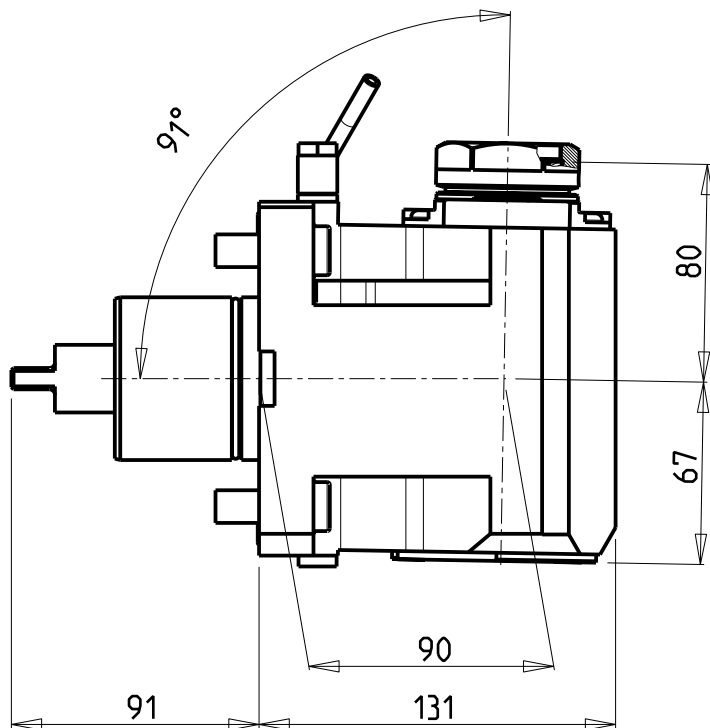

PER PORTAUTENSILI MODULARI MTSK-40 VEDI PAG. TBL300-1-40  
 FOR MTSK-40 QUIK CHANGE TOOLHOLDERS CLAMPINGS SEE PAGE TBL300-1-40  
 FUER MTSK-40 MODULARE WERKZEUGAUFNAHMEN SIEHE SEITE TBL300-1-40

Cod. MT	Mandrino Spindel Spindel	I	RPM	Coppia Max Max Torque Max Drehmoment	Reversibile lato mandrino/contromandrino Reversible sub/main spindle side Umkehrbare Spindel-seite/ Gegenspindel-seite	Lubr.esterna Ext. coolant Aussenkuehlung	CHIAVI NON INCLUSE Keys not included Schlüssel nicht einbegriffen
MNL0900140	MTSK-40	1:1	6000	50Nm	X	X	CHUB46 OKU0650004 *

- Chiave inclusa
- Key included
- Schlüssel inbegriffen

MT RENT

MT CUT T25Y/SY - MT CUT T32Y/SY

MODULO MOTORIZZATO ASSIALE MTSK PER POLIGONATURA INTERNA H=90mm

Axial MTSK driven tool for internal polygon-making H=90mm

Axial MTSK angetriebenes Werkzeug fuer interne Facettierung H=90mm

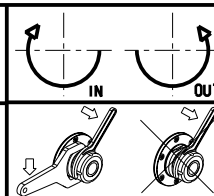

**M.T. srl**

Via Casino Albini 480  
 Tel. 0541/956034-957884  
 Fax 0541/956341  
 47842 S. GIOVANNI IN M. (RN)  
 e-mail: mtma@mtmarchetti.com  
 http://www.mtmarchetti.com

PRODUZIONE MODULI ROTANTI



PAGINA MTR231-1-10-K

Subject to change without notice.

10/2018

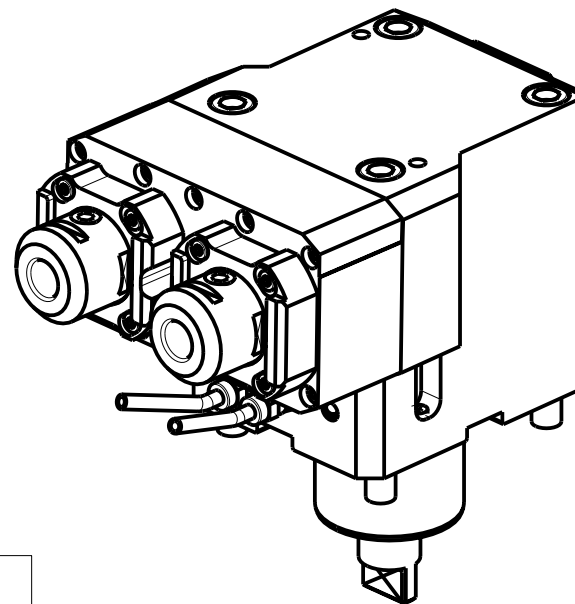
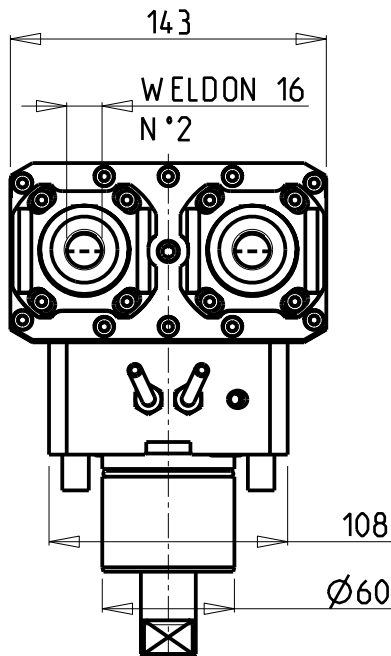
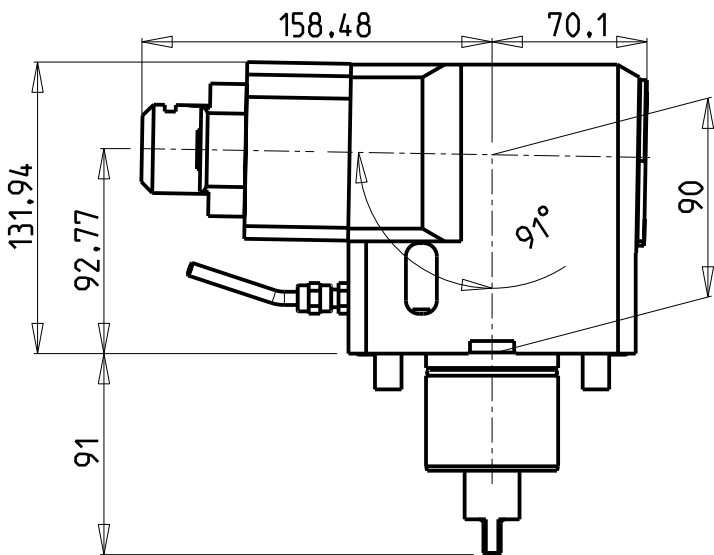
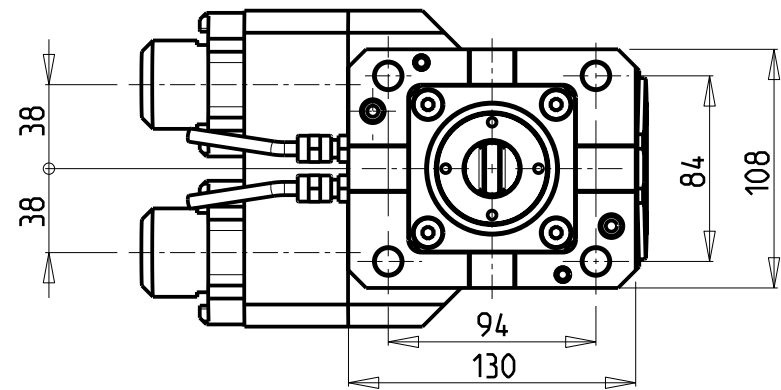

### ATTENZIONE - ATTENTION - ACHTUNG

- Per lo smontaggio degli utensili utilizzare sempre la chiave di contrasto come indicato nel manuale d'uso.
- For disassembly of the tools use always the contrast key as mentioned in the user instructions.
- Fuer das Abmontieren der Werkzeuge immer den Gegenschluessel benutzen wie in der Bedienungsanleitung erwaeht.

Cod. MT	Mandrino Spindle Spindel	I	RPM	Coppia Max Max Torque Max Drehmoment	Reversibile lato mandrino/contromandrino Reversible sub/main spindle side Umkehrbare Spindel-seite/ Gegenspindel-seite	Lubr.esterna Ext. coolant Aussenkuehlung	CHIAVI INCLUDE Keys included Schluessel inbegriffen
MNL0940616	WELDON 16	1:1	6000	50Nm	X	X	SAU0070027

MT RENT

MT CUT T25Y/SY - MT CUT T32Y/SY

MODULO MOTORIZZATO ASSIALE 2 USCITE IN Y PER POLIGONATURA INTERNA H=90mm  
 Axial Single side twin head driven tool in Y for internal polygon-making H=90mm  
 Axial angetriebenes Werkzeug 2 Ausgaenge in Y fuer interne Facettierung H=90mm

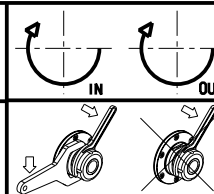

**M.T. srl**

Via Casino Albini 480  
 Tel. 0541/956034-957884  
 Fax 0541/956341  
 47842 S. GIOVANNI IN M. (RN)  
 e-mail: mtma@mtmarchetti.com  
 http://www.mtmarchetti.com

PRODUZIONE MODULI ROTANTI



PAGINA MTR233-1-10

Subject to change without notice.

10/2018

**ATTENZIONE - ATTENTION - ACHTUNG**

- Per lo smontaggio degli utensili utilizzare sempre la chiave di contrasto come indicato nel manuale d'uso.
- For disassembly of the tools use always the contrast key as mentioned in the user instructions.
- Fuer das Abmontieren der Werkzeuge immer den Gegenschlüssel benutzen wie in der Bedienungsanleitung erwaeht.

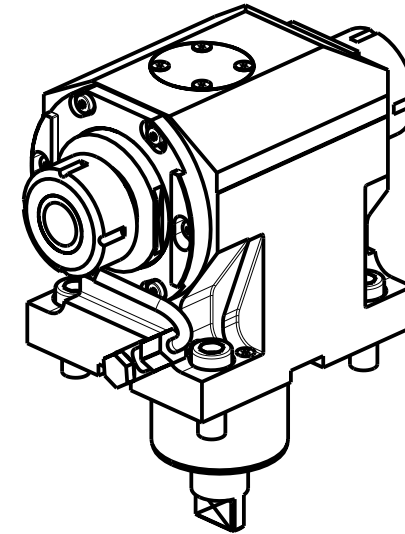
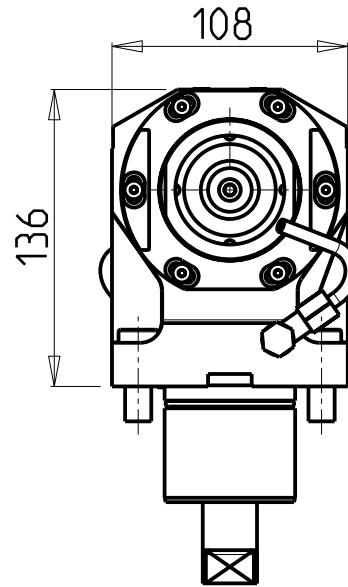
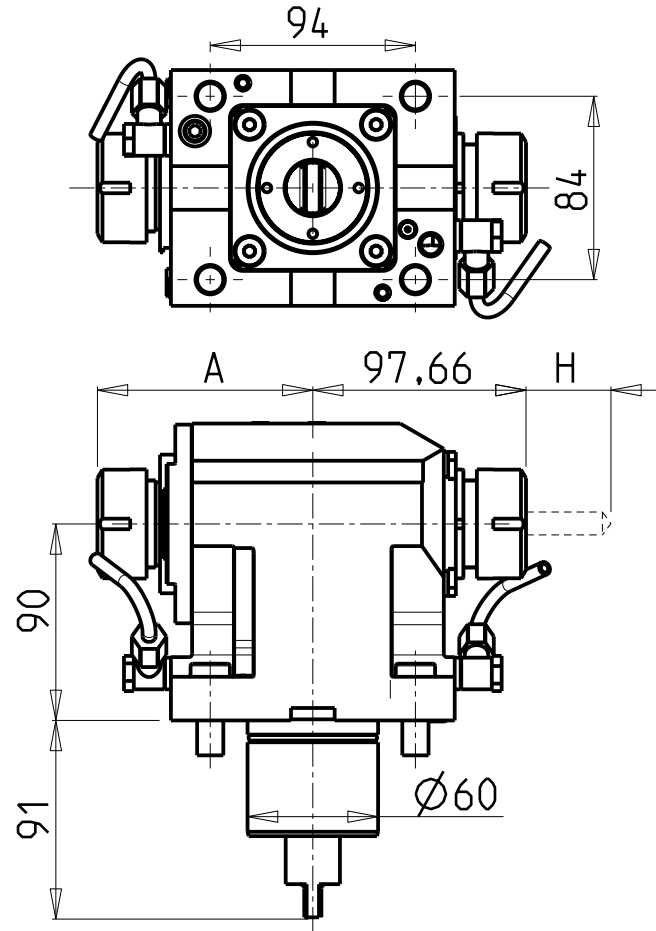

- Chiave inclusa
- Key included
- Schlüssel inbegriffen

Cod. MT	Mandrino Spindle Spindel	I	RPM	Coppia Max Max Torque Max Drehmoment	Reversibile lato mandrino/contromandrino Reversible sub/main spindle side Umkehrbare Spindel-seite/ Gegenspindel-seite	Lubr.esterna Ext. coolant Ausseukuehlung	A	H Max Lato contromand. Subspindle side Gegenspindel-seite	CHIAVI NON INCLUSE Keys not included Schlüssel nicht einbegriffen		
MNL0830232	ER32+ER32	1:1	6000	100Nm	X	X	98.7	74	OKU0430007	CHSTER32	-
MNL0830240	ER40+ER32	1:1	6000	100Nm	X	X	101.7	74	OKU0430007	CHSTER32	CHSTER40

**MT RENT**  
**MT CUT T25Y/SY - MT CUT T32Y/SY**

**MODULO MOTORIZZATO ASSIALE BISPORGENTE**  
 Axial opposite face twin driven tool  
 Axial angetriebenes Werkzeug halb vorspringend

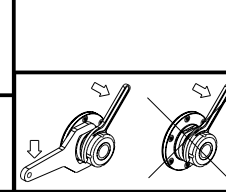

**M.T. srl**  
 Via Casino Albini 480  
 Tel. 0541/956034-957884  
 Fax 0541/956341  
 47842 S. GIOVANNI IN M. (RN)  
 e-mail: mtma@mtmarchetti.com  
 http://www.mtmarchetti.com

PRODUZIONE MODULI ROTANTI



PAGINA MTR240-1-10

Subject to change without notice.

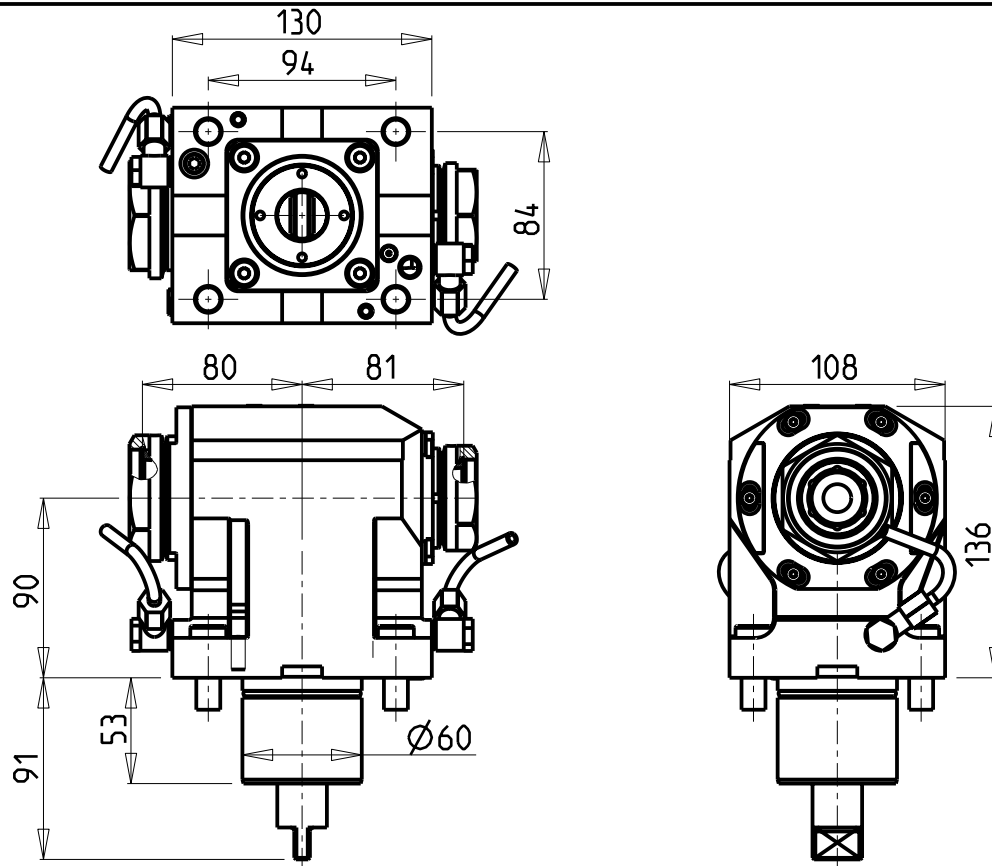

### ATTENZIONE - ATTENTION - ACHTUNG

- Per lo smontaggio degli utensili utilizzare sempre la chiave di contrasto come indicato nel manuale d'uso.
- For disassembly of the tools use always the contrast key as mentioned in the user instructions.
- Fuer das Abmontieren der Werkzeuge immer den Gegenschlüssel benutzen wie in der Bedienungsanleitung erwaeht.

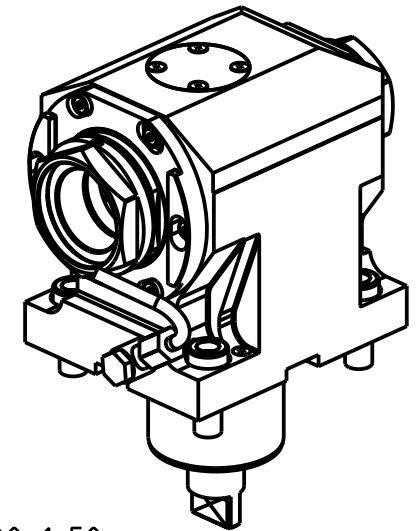

PER PORTAUTENSILI MODULARI MTSK-40 VEDI PAG. TBL300-1-40 E PER MTSK-50 VEDI PAG. TBL300-1-50  
 FOR MTSK-40 QUIK CHANGE TOOLHOLDERS CLAMPINGS SEE PAGE TBL300-1-40 AND FOR MTSK-50 SEE PAGE TBL300-1-50  
 FUER MTSK-40 MODULARE WERKZEUGAUFNAHMEN SIEHE SEITE TBL300-1-40 UND FUER MTSK-50 SIEHE SEITE TBL300-1-50

Cod. MT	Mandrino Spindle Spindel	I	RPM	Coppia Max Max Torque Max Drehmoment	Reversibile lato mandrino/contromandrino Reversible sub/main spindle side Umkehrbare Spindel-seite/ Gegenspindel-seite	Lubr.esterna Ext. coolant Aussenkuehlung	CHIAVI NON INCLUSE Keys not included Schluesssel nicht einbegriffen		
							CHUB46	CHUB55	OKU0430007 *
MNL1015040	MTSK-50+MTSK-40	1:1	6000	100Nm	X	X	CHUB46	CHUB55	OKU0430007 *

- Chiave inclusa
- Key included
- Schluesssel inbegriffen

MT RENT

MT CUT T25Y/SY - MT CUT T32Y/SY

MODULO MOTORIZZATO ASSIALE BISPORGENTE MTSK

Axial MTSK opposite face twin driven tool

Axial MTSK angetriebenes Werkzeug halb vorspringend

Subject to change without notice.

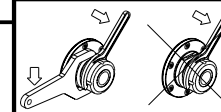

**M.T. srl**

Via Casino Albini 480  
 Tel. 0541/956034-957884  
 Fax 0541/956341  
 47842 S. GIOVANNI IN M. (RN)  
 e-mail: mtma@mtmarchetti.com  
 http://www.mtmarchetti.com

PRODUZIONE MODULI ROTANTI



PAGINA MTR240-1-10-K

**ATTENZIONE - ATTENTION - ACHTUNG**

- Per lo smontaggio degli utensili utilizzare sempre la chiave di contrasto come indicato nel manuale d'uso.
- For disassembly of the tools use always the contrast key as mentioned in the user instructions.
- Fuer das Abmontieren der Werkzeuge immer den Gegenschlüssel benutzen wie in der Bedienungsanleitung erwaeht.

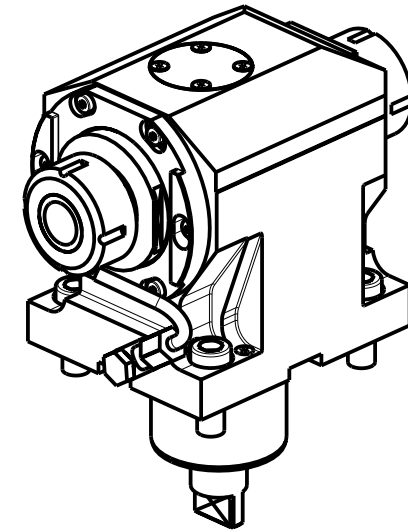
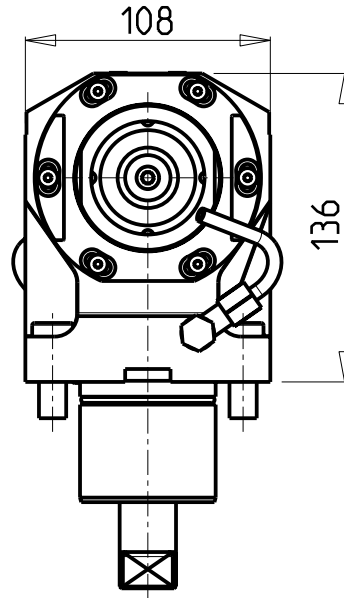
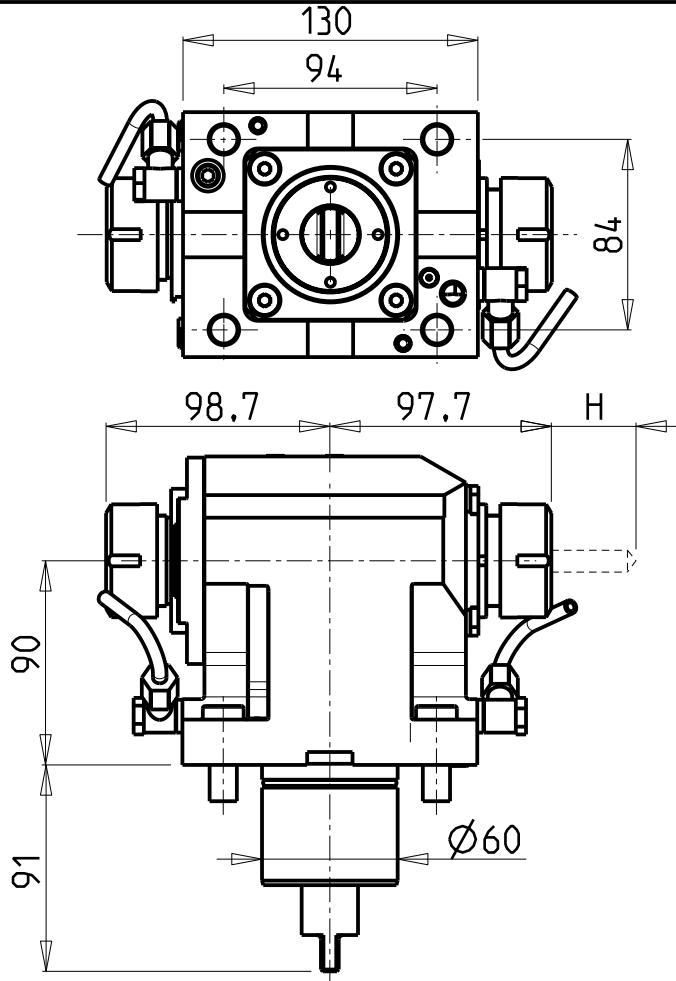

Cod. MT	Mandrino Spindle Spindel	I	RPM	Coppia Max Max Torque Max Drehmoment	Reversibile lato mandrino/contromandrino Reversible sub/main spindle side Umkehrbare Spindel-seite/ Gegenspindel-seite	Lubr.esterna Ext. coolant Aussenkuehlung	H Max Lato contromand. Subspindle side Gegenspindel-seite	CHIAVI NON INCLUDE Keys not included Schlüssel nicht einbegriffen
MNL0820232	ER32+ER32	1:1	10000	100Nm	X	X	74	OKU0430007 • CHSTER32

- Chiave inclusa
- Key included
- Schlüssel inbegriffen

MT RENT  
MT CUT T25Y/SY - MT CUT T32Y/SY

MODULO MOTORIZZATO ASSIALE BISPORGENTE 10000 RPM  
Axial opposite face twin driven tool 10000 rpm  
Axial angetriebenes Werkzeug halb vorspringend 10000 rpm

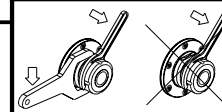

**M.T. srl**  
Via Casino Albini 480  
Tel. 0541/956034-957884  
Fax 0541/956341  
47842 S. GIOVANNI IN M. (RN)  
e-mail: mtma@mtmarchetti.com  
http://www.mtmarchetti.com

PRODUZIONE MODULI ROTANTI



PAGINA MTR240-1-11

Subject to change without notice.

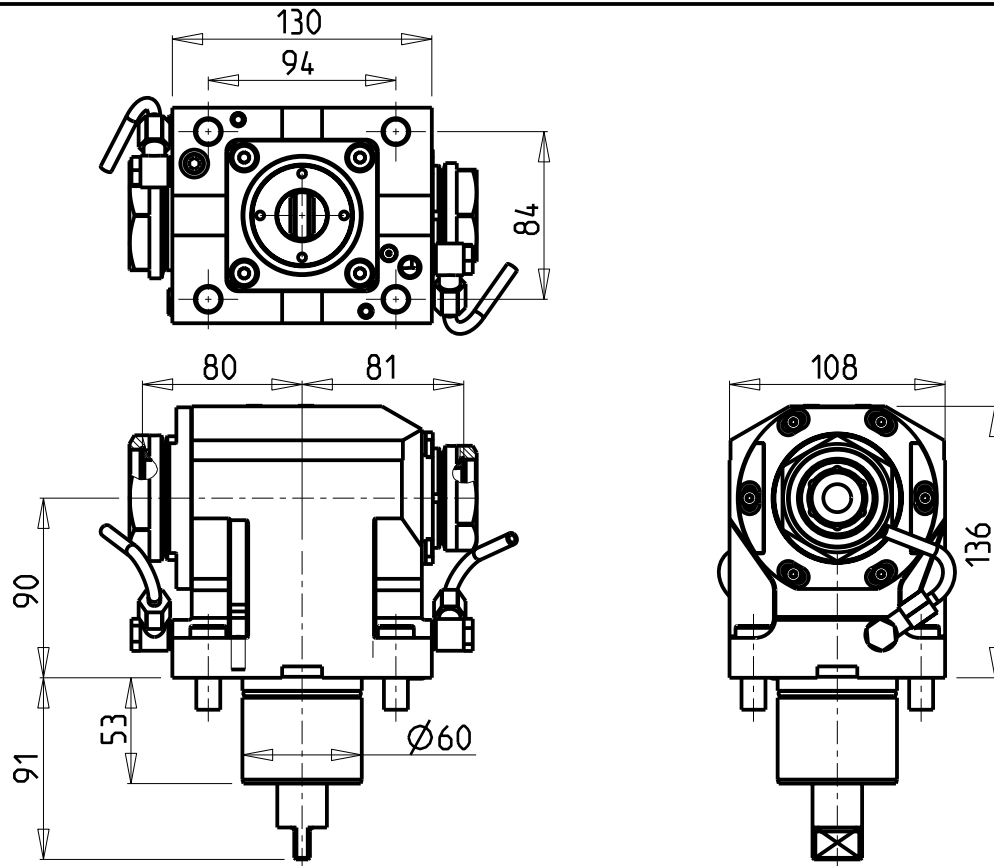

**ATTENZIONE - ATTENTION - ACHTUNG**

- Per lo smontaggio degli utensili utilizzare sempre la chiave di contrasto come indicato nel manuale d'uso.
- For disassembly of the tools use always the contrast key as mentioned in the user instructions.
- Fuer das Abmontieren der Werkzeuge immer den Gegenschlüssel benutzen wie in der Bedienungsanleitung erwaeht.

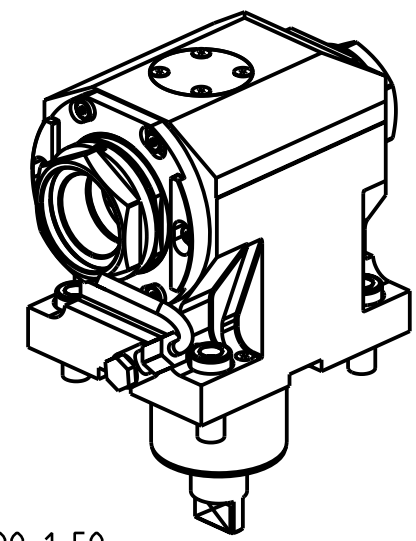

PER PORTAUTENSILI MODULARI MTSK-40 VEDI PAG. TBL300-1-40 E PER MTSK-50 VEDI PAG. TBL300-1-50  
 FOR MTSK-40 QUIK CHANGE TOOLHOLDERS CLAMPINGS SEE PAGE TBL300-1-40 AND FOR MTSK-50 SEE PAGE TBL300-1-50  
 FUER MTSK-40 MODULARE WERKZEUGAUFNAHMEN SIEHE SEITE TBL300-1-40 UND FUER MTSK-50 SIEHE SEITE TBL300-1-50

Cod. MT	Mandrino Spindle Spindel	I	RPM	Coppia Max Max Torque Max Drehmoment	Reversibile lato mandrino/contromandrino Reversible sub/main spindle side Umkehrbare Spindel-seite/ Gegenspindel-seite	Lubr.esterna Ext. coolant Aussenkuehlung	CHIAVI NON INCLUSE Keys not included Schluesssel nicht einbegriffen		
							CHUB46	CHUB55	OKU0430007 *
MNL1005040	MTSK-50+MTSK-40	1:1	10000	100Nm	X	X	CHUB46	CHUB55	OKU0430007 *

- Chiave inclusa
- Key included
- Schluesssel inbegriffen

**MT RENT**  
 MT CUT T25Y/SY - MT CUT T32Y/SY

MODULO MOTORIZZATO ASSIALE BISPORGENTE MTSK 10000 RPM  
 Axial MTSK opposite face twin driven tool 10000 rpm  
 Axial MTSK angetriebenes Werkzeug halb vorspringend 10000 rpm

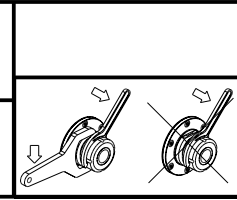

**M.T. srl**  
 Via Casino Albini 480  
 Tel. 0541/956034-957884  
 Fax 0541/956341  
 47842 S. GIOVANNI IN M. (RN)  
 e-mail: mtma@mtmarchetti.com  
 http://www.mtmarchetti.com

PRODUZIONE MODULI ROTANTI

PAGINA MTR240-1-11-K

Subject to change without notice.

**ATTENZIONE - ATTENTION - ACHTUNG**

- Per lo smontaggio degli utensili utilizzare sempre la chiave di contrasto come indicato nel manuale d'uso.
- For disassembly of the tools use always the contrast key as mentioned in the user instructions.
- Fuer das Abmontieren der Werkzeuge immer den Gegenschlüssel benutzen wie in der Bedienungsanleitung erwaeht.

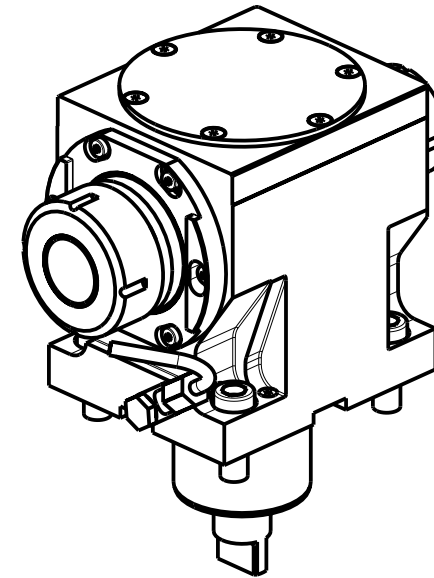
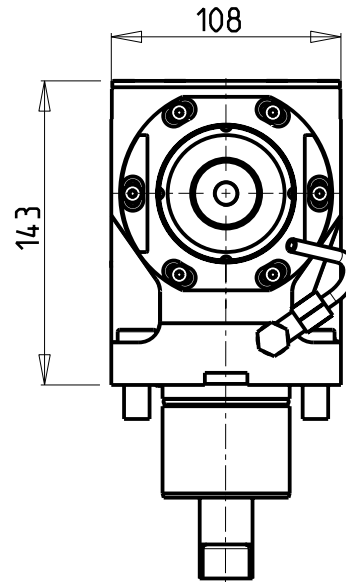
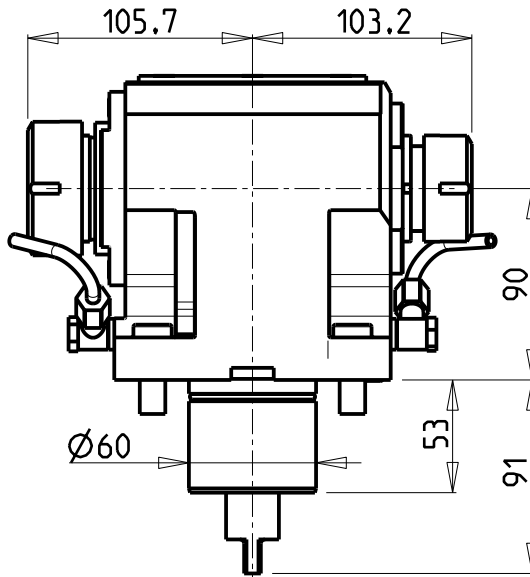
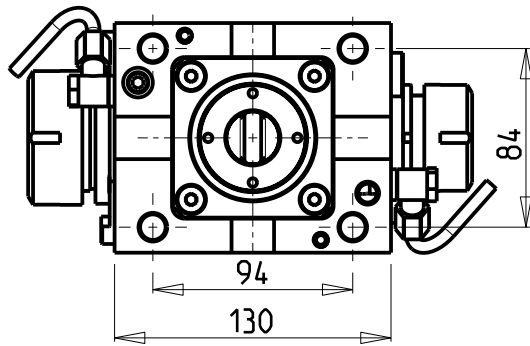

Cod. MT	Mandrino Spindle Spindel	I	RPM	Coppia Max Max Torque Max Drehmoment	Reversibile lato mandrino/contromandrino Reversible sub/main spindle side Umkehrbare Spindel-seite/ Gegenspindel-seite	Lubr.esterna Ext. coolant Aussenkuehlung	CHIAVI NON INCLUSE Keys not included Schluesssel nicht einbegriffen		
MNL0914032	ER40+ER32	2:1	3000	130Nm	X	X	OKU0430007	CHSTER40	CHSTER32

- Chiave inclusa
- Key included
- Schluesssel inbegriffen

MT RENT  
MT CUT T25Y/SY - MT CUT T32Y/SY

MODULO MOTORIZZATO ASSIALE BISPORGENTE RIDOTTO I=2:1  
Axial geared-down I=2:1 opposite face twin driven tool  
Axial angetriebenes Werkzeug halb vorspringend untersetzt I=2:1

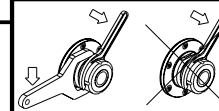

**M.T. srl**  
Via Casino Albini 480  
Tel. 0541/956034-957884  
Fax 0541/956341  
47842 S. GIOVANNI IN M. (RN)  
e-mail: mtma@mtmarchetti.com  
http://www.mtmarchetti.com

PRODUZIONE MODULI ROTANTI



PAGINA MTR247-1-10

Subject to change without notice.

10/2018

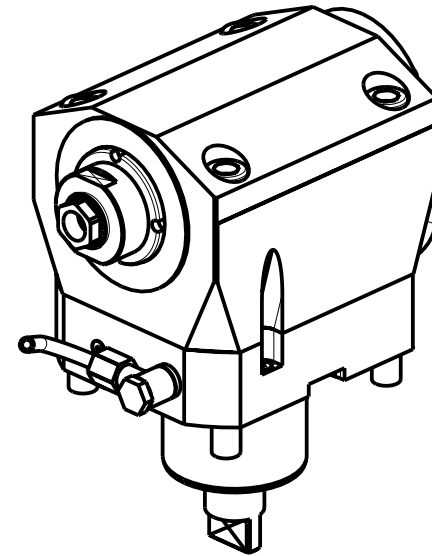
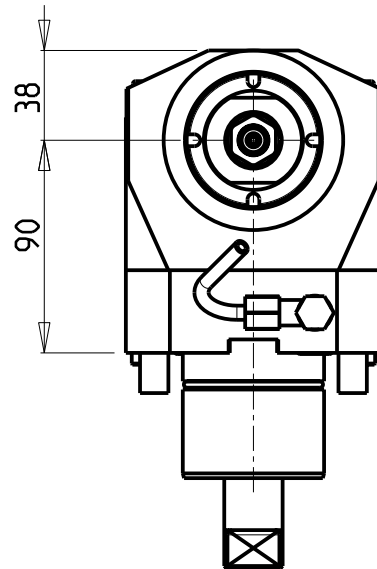
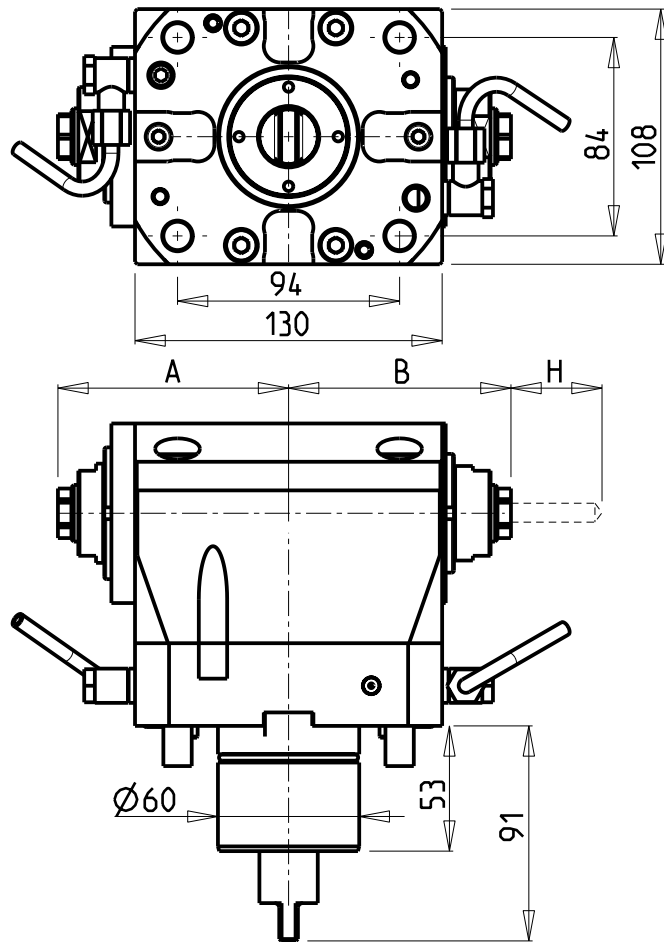

### ATTENZIONE - ATTENTION - ACHTUNG

- Per lo smontaggio degli utensili utilizzare sempre la chiave di contrasto come indicato nel manuale d'uso.
- For disassembly of the tools use always the contrast key as mentioned in the user instructions.
- Fuer das Abmontieren der Werkzeuge immer den Gegenschlüssel benutzen wie in der Bedienungsanleitung erwaeht.

Cod. MT	Mandrino Spindle Spindel	I	RPM	Coppia Max Max Torque Max Drehmoment	Reversibile lato mandrino/contromandrino Reversible sub/main spindle side Umkehrbare Spindel-seite/ Gegenspindel-seite	Lubr.esterna Ext. coolant Aussenkuehlung	A	B	H Max Lato contromand. Subspindle side Gegenspindel-seite	CHIAVI NON INCLUSE Keys not included Schlüssel nicht einbegriffen	
										C HUB36	C HUB19_SP3
MNL0450116	ERA16+ERA16	1:2	12000	50Nm	X	X	97.63	94.13	77.6	C HUB36	C HUB19_SP3
MNL0450120	ERA20+ERA20	1:2	12000	50Nm	X	X	95.73	93.73	78	C HUB36	C HUB22

MT RENT

MT CUT T25Y/SY - MT CUT T32Y/SY

MODULO MOTORIZZATO ASSIALE BISPORGENTE MOLTIPLICATO I=1:2

Axial geared-up I=1:2 opposite face twin driven tool

Axial angetriebenes Werkzeug halb vorspringend uebersetzt I=1:2

Subject to change without notice.

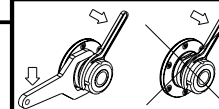

**M.T. srl**

Via Casino Albini 480  
Tel. 0541/956034-957884  
Fax 0541/956341  
47842 S. GIOVANNI IN M. (RN)  
e-mail: mtma@mtmarchetti.com  
http://www.mtmarchetti.com

PRODUZIONE MODULI ROTANTI



PAGINA MTR250-1-10



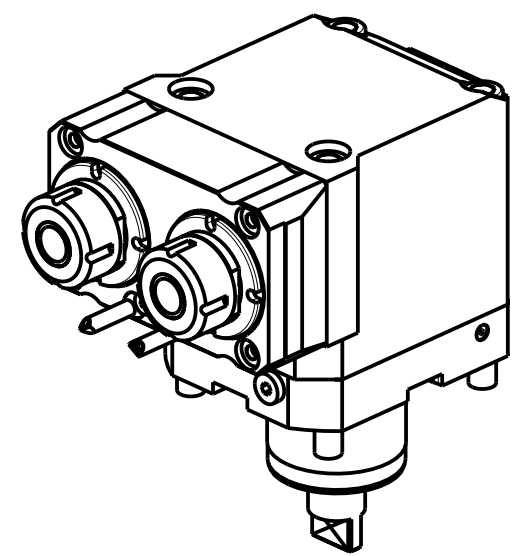
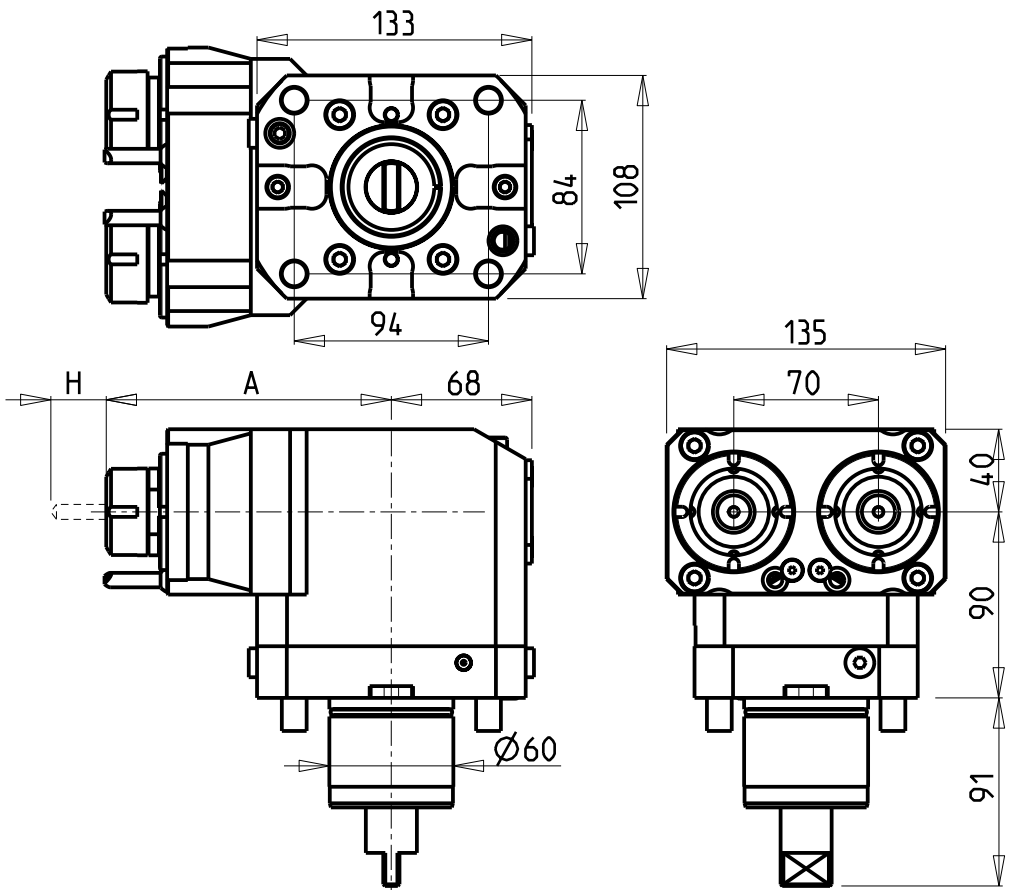

**ATTENZIONE - ATTENTION - ACHTUNG**

- Per lo smontaggio degli utensili utilizzare sempre la chiave di contrasto come indicato nel manuale d'uso.
- For disassembly of the tools use always the contrast key as mentioned in the user instructions.
- Fuer das Abmontieren der Werkzeuge immer den Gegenschlüssel benutzen wie in der Bedienungsanleitung erwaeht.

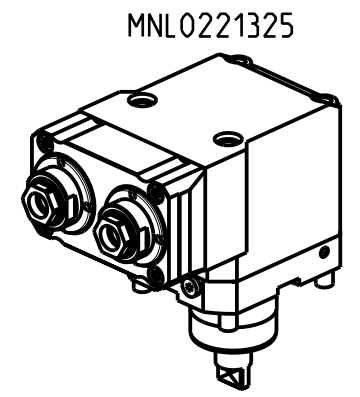

MNL0221325

Cod. MT	Mandrino Spindle Spindel	I	RPM	Coppia Max Max Torque Max Drehmoment	Reversibile lato mandrino/contromandrino Reversible sub/main spindle side Umkehrbare Spindel-seite/ Gegenspindel-seite	Lubr.interna Coolant through Innenkuehlung	Lubr.esterna Ext. coolant Aussenkuehlung	A	H max Lato contromandrino Subspindle side Gegenspindel-seite	CHIAVI NON INCLUSE Keys not included Schluessel nicht einbegriffen	
										CHUB36	CHSTER25
MNL0220225	ER25	1:1	6000	40Nm	X		X	137.96	28.5	CHUB36	CHSTER25
MNL0221225	ER25	1:1	6000	40Nm	X	P=70bar	X	162.66	6.95	CHUB36	CHSTER25
MNL0221325	ER A 25	1:1	6000	40Nm	X	P=70bar	X	156.03	14.5	CHUB38	CHUB27

MT RENT  
 MT CUT T25Y/SY - MT CUT T32Y/SY

MODULO MOTORIZZATO ASSIALE 2 USCITE IN Y  
 Axial Single side twin head driven tool in Y  
 Axial angetriebenes Werkzeug 2 Ausgaenge in Y

Subject to change without notice.

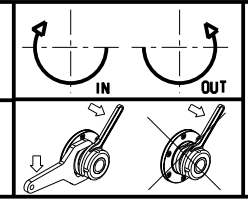

**M.T. srl**  
 Via Casino Albini 480  
 Tel. 0541/956034-957884  
 Fax 0541/956341  
 47842 S. GIOVANNI IN M. (RN)  
 e-mail: mtma@mtmarchetti.com  
 http://www.mtmarchetti.com

PRODUZIONE MODULI ROTANTI

PAGINA MTR260-1-10

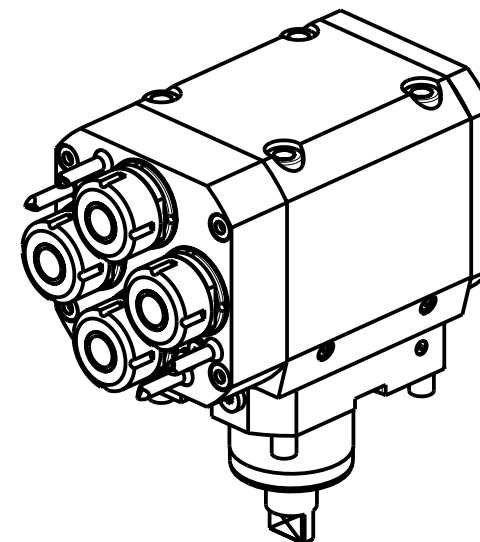
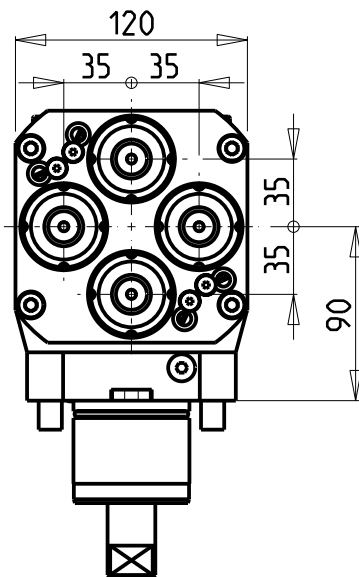
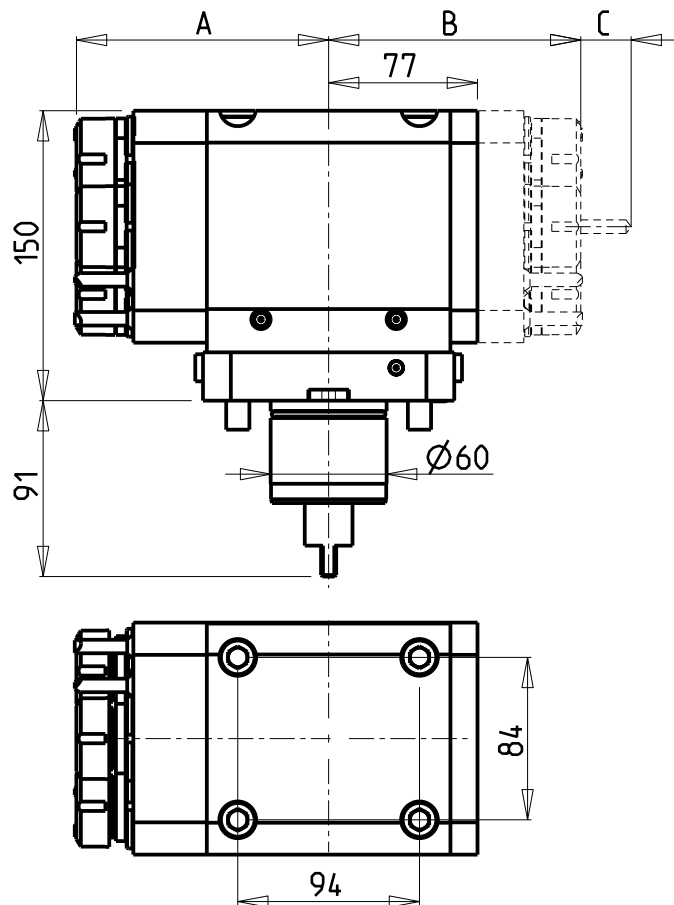

**ATTENZIONE - ATTENTION - ACHTUNG**

- Per lo smontaggio degli utensili utilizzare sempre la chiave di contrasto come indicato nel manuale d'uso.
- For disassembly of the tools use always the contrast key as mentioned in the user instructions.
- Fuer das Abmontieren der Werkzeuge immer den Gegenschlüssel benutzen wie in der Bedienungsanleitung erwäehnt.

Cod. MT	Mandrino Spindle Spindel	I	RPM	Coppia Max Max Torque Max Drehmoment	N°Utensili N°Tools N°Werkzeuge	Reversibile lato mandrino/contromandrino Reversible sub/main spindle side Umkehrbare Spindel-seite/ Gegenspindel-seite	Lubr.esterna Ext. coolant Ausßenkeuhlung	A	B	C max Lato contromandrino Subspindle side Gegenspindel-seite	CHIAVI INCLUSE Keys included Schluesel inbegriffen	
MNL0230425	ER25	1:1	6000	30Nm	4	X	X	130.46	-	-	MNL0210007	MNL0210008
MNL0234425	ER25+ER25	1:1	6000	30Nm	4+4		X	130.46	130.46	36	MNL0210007	MNL0210008

**MT RENT**  
 MT CUT T25Y/SY - MT CUT T32Y/SY  
 MODULO MOTORIZZATO ASSIALE 4/8 USCITE  
 Axial multiple 4/8 outlet driven tool  
 Axial angetriebenes Mehrspindel-Werkzeug 4/8 Ausgaenge

**M.T. srl**  
 Via Casino Albini 480  
 Tel. 0541/956034-957884  
 Fax 0541/956341  
 47842 S. GIOVANNI IN M. (RN)  
 e-mail: mtma@mtmarchetti.com  
 http://www.mtmarchetti.com

PRODUZIONE MODULI ROTANTI  
  
 PAGINA MTR270-1-00

Subject to change without notice.

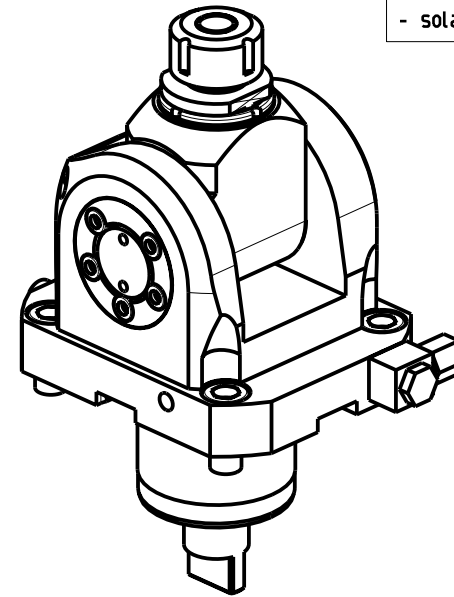
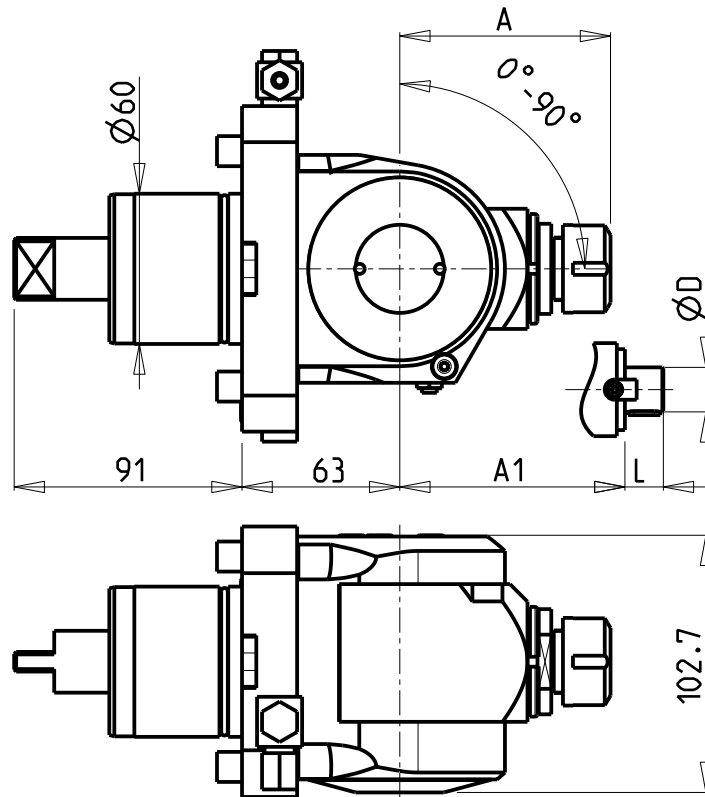
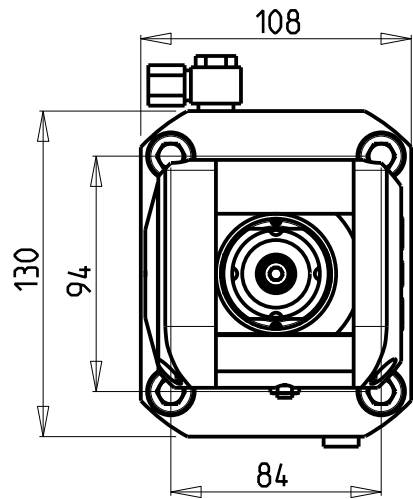

ATTENZIONE - ATTENTION - ACHTUNG

- FINO AD ESAURIMENTO SCORTE
- clearance sale
- solange vorrat

Cod. MT	Mandrino Spindle Spindel	I	RPM	Coppia Max Max Torque Max Drehmoment	Reversibile lato mandrino/contromandrino Reversible sub/main spindle side Umkehrbare Spindel-seite/ Gegenspindel-seite	Lubr.esterna Ext. coolant Aussenkuehlung	A	A1	D	L	CHIAVI INCLUSE Keys included Schluessel inbegriffen		
											CHUB36	CHSTER20	CHESL10
MNL0170020	ER20	1:1	6000	40Nm	X	X	84.16	-	-	-	CHUB36	CHSTER20	CHESL10
MNL0170025	ER25	1:1	6000	40Nm	X	X	85.66	-	-	-	CHUB36	CHSTER25	CHESL10
MNL0171617	Ø16x17	1:1	6000	40Nm	X	X	-	65	16	17	CHUB36	CH_VTCROCE_M08	CHESL10
MNL0172219	Ø22x19	1:1	6000	40Nm	X	X	-	66	22	19	CHUB36	CH_VTCROCE_M10	CHESL10
MNL0171905	Ø3/4"x3/4"	1:1	6000	40Nm	X	X	-	65	3/4"	3/4"	CHUB36	CH_VTCROCE_M08	CHESL10

MT RENT

MT CUT T25Y/SY - MT CUT T32Y/SY

MODULO MOTORIZZATO ORIENTABILE 0-90°

0-90° adjustable angle driven tool

Angetriebenes Werkzeug schwenkbar 0-90°

Subject to change without notice.

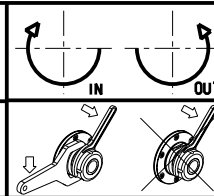

**M.T. srl**

Via Casino Albini 480  
Tel. 0541/956034-957884  
Fax 0541/956341  
47842 S. GIOVANNI IN M. (RN)  
e-mail: mtma@mtmarchetti.com  
http://www.mtmarchetti.com

PRODUZIONE MODULI ROTANTI



PAGINA MTR330-1-00

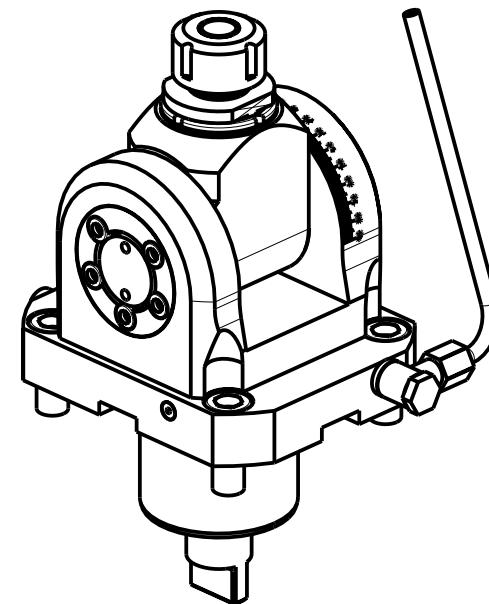
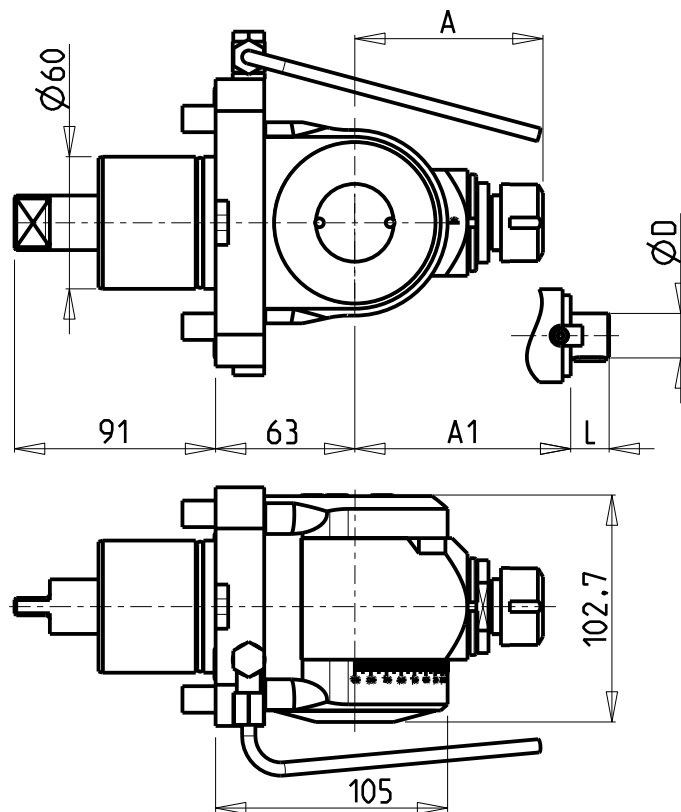
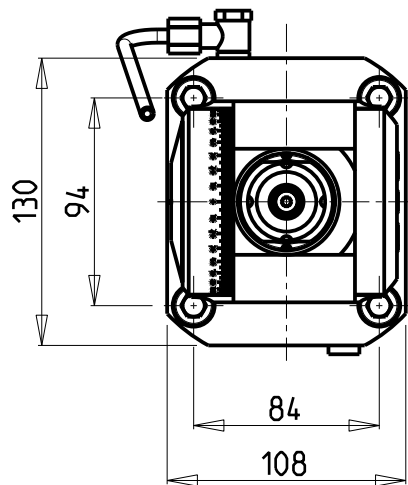

Cod. MT	Mandrino Spindle Spindel	i	RPM	Coppia Max Max Torque Max Drehmoment	Reversibile lato mandrino/contromandrino Reversible sub/main spindle side Umkehrbare Spindel-seite/ Gegenspindel-seite	Lubr. esterna Ext. coolant Aussenkuehlung	A	A1	D	L	CHIAVI INCLUSE Keys included Schluessel inbegriffen		
											CHUB36	CHSTER	CHESL10
MNL0930120	ER20	1:1	6000	40Nm	X	X	85.16	-	-	-	CHUB36	CHSTER20	CHESL10
MNL0930125	ER25	1:1	6000	40Nm	X	X	86.16	-	-	-	CHUB36	CHSTER25	CHESL10
MNL0930516	Ø16x17	1:1	6000	40Nm	X	X	-	65	16	17	CHUB36	CH_VTCROCE_M08	CHESL10
MNL0930522	Ø22x19	1:1	6000	40Nm	X	X	-	66	22	19	CHUB36	CH_VTCROCE_M10	CHESL10
MNL0930519	Ø3/4"x3/4"	1:1	6000	40Nm	X	X	-	65	3/4"	3/4"	CHUB36	CH_VTCROCE_M08	CHESL10

MT RENT  
MT CUT T25Y/SY - MT CUT T32Y/SY

MODULO MOTORIZZATO ORIENTABILE ±90°  
±90° adjustable angle driven tool  
Angetriebenes Werkzeug schwenkbar ±90°

Subject to change without notice.

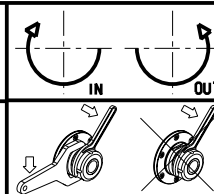

**M.T. srl**  
Via Casino Albini 480  
Tel. 0541/956034-957884  
Fax 0541/956341  
47842 S. GIOVANNI IN M. (RN)  
e-mail: mtma@mtmarchetti.com  
http://www.mtmarchetti.com

PRODUZIONE MODULI ROTANTI



PAGINA MTR333-1-00

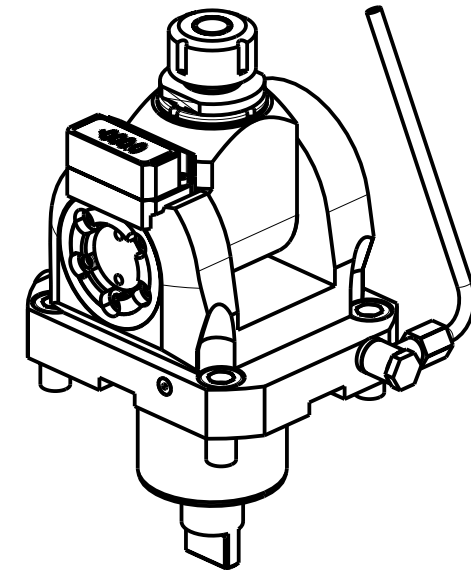
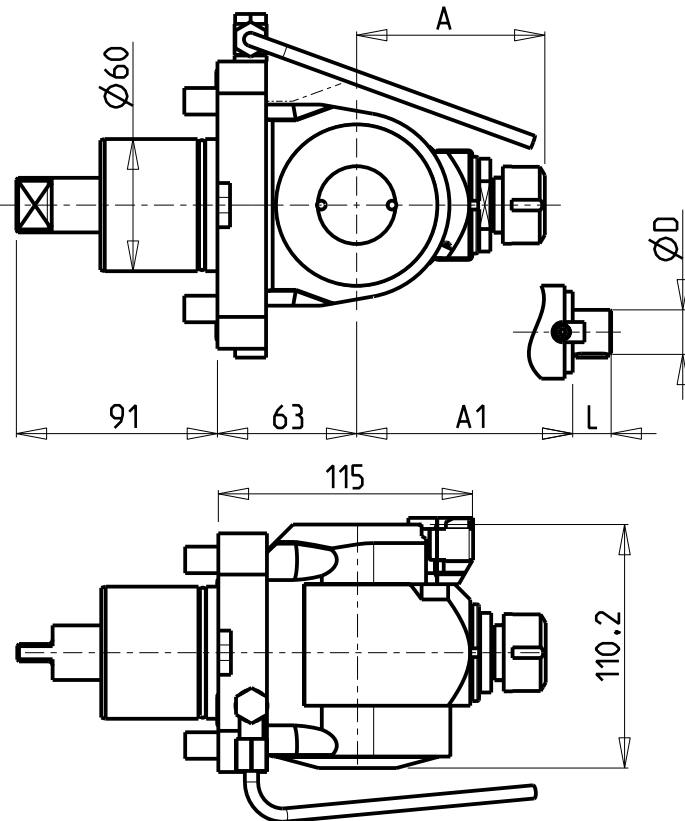
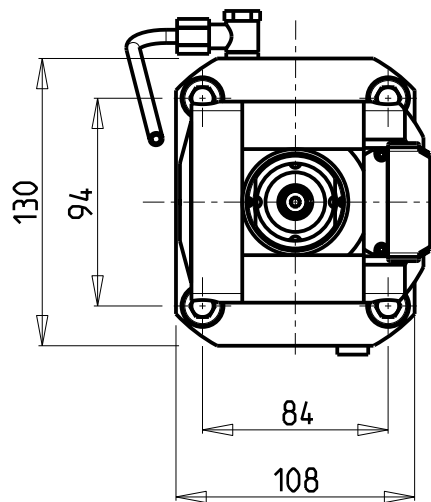

Cod. MT	Mandrino Spindle Spindel	i	RPM	Coppia Max Max Torque Max Drehmoment	Reversibile lato mandrino/contromandrino Reversible sub/main spindle side Umkehrbare Spindelsete/ Gegenspindelsete	Lubr.esterna Ext. coolant Aussenkuehlung	A	A1	D	L	CHIAVI INCLUSE Keys included Schluessel inbegriffen		
											CHUB36	CHSTER20	CHESL10
MNL0890120	ER20	1:1	6000	40Nm	X	X	85.16	-	-	-	CHUB36	CHSTER20	CHESL10
MNL0890125	ER25	1:1	6000	40Nm	X	X	86.16	-	-	-	CHUB36	CHSTER25	CHESL10
MNL0890516	$\varnothing 16 \times 17$	1:1	6000	40Nm	X	X	-	65	16	17	CHUB36	CH_VTCROCE_M08	CHESL10
MNL0890522	$\varnothing 22 \times 19$	1:1	6000	40Nm	X	X	-	66	22	19	CHUB36	CH_VTCROCE_M10	CHESL10
MNL0890519	$\varnothing 3/4 \times 3/4$	1:1	6000	40Nm	X	X	-	65	3/4"	3/4"	CHUB36	CH_VTCROCE_M08	CHESL10

MT RENT  
MT CUT T25Y/SY - MT CUT T32Y/SY

MODULO MOTORIZZATO ORIENTABILE  $\pm 90^\circ$  CON NONIO DIGITALE  
 $\pm 90^\circ$  adjustable angle driven tool with digital display  
Angetriebenes Werkzeug schwenkbar  $\pm 90^\circ$  mit digital display

Subject to change without notice.

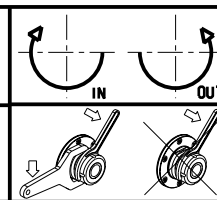

**M.T. srl**  
Via Casino Albini 480  
Tel. 0541/956034-957884  
Fax 0541/956341  
47842 S. GIOVANNI IN M. (RN)  
e-mail: mtma@mtmarchetti.com  
<http://www.mtmarchetti.com>

PRODUZIONE MODULI ROTANTI



PAGINA MTR333-1-01

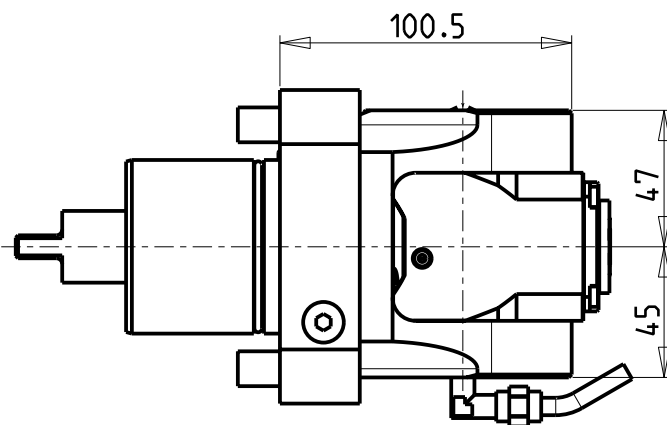
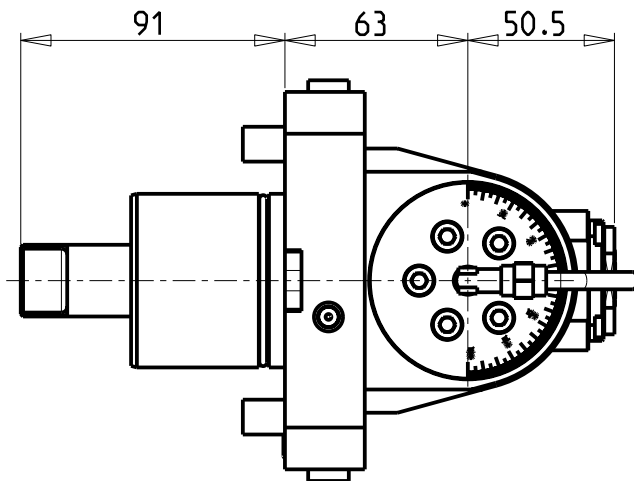
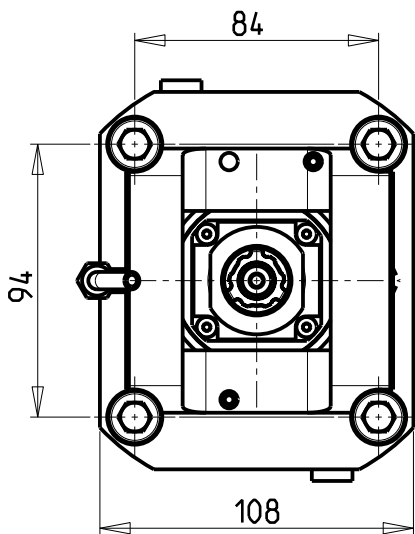

### ATTENZIONE - ATTENTION - ACHTUNG

- Per lo smontaggio degli utensili utilizzare sempre la chiave di contrasto come indicato nel manuale d'uso.
- For disassembly of the tools use always the contrast key as mentioned in the user instructions.
- Fuer das Abmontieren der Werkzeuge immer den Gegenschlüssel benutzen wie in der Bedienungsanleitung erwäehnt.

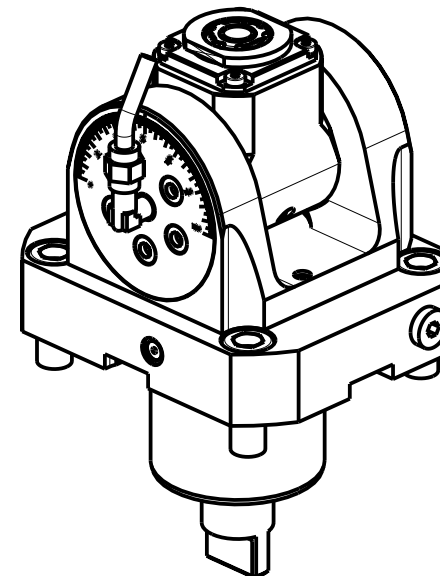

Cod. MT	Mandrino Spindle Spindel	I	RPM	Coppia Max Max Torque Max Drehmoment	Lubrificazione int. Coolant through Innenkuehlung	Lubrificazione est. Ext. coolant Aussenkuehlung	CHIAVI INCLUSE Keys included Schluessel inbegriffen			
MNL0640120	ERA20	1:1	6000	30Nm		X	CHUB22	CHUB36	CHTAER20ZC	CHESL10
MNL0640220	ERA20	1:1	6000	30Nm	P=70bar	X	CHUB22	CHUB36	CHTAER20ZC	CHESL10

MT RENT  
MT CUT T25Y/SY - MT CUT T32Y/SY

MODULO MOTORIZZATO ORIENTABILE +/-90°  
+/-90° adjustable angle driven tool  
Angetriebenes Werkzeug schwenkbar +/-90°

Subject to change without notice.

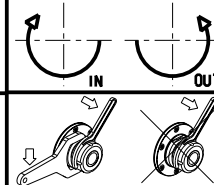

**M.T. srl**

Via Casino Albini 480  
Tel. 0541/956034-957884  
Fax 0541/956341  
47842 S. GIOVANNI IN M. (RN)  
e-mail: mtma@mtmarchetti.com  
http://www.mtmarchetti.com

PRODUZIONE MODULI ROTANTI



PAGINA MTR335-1-00

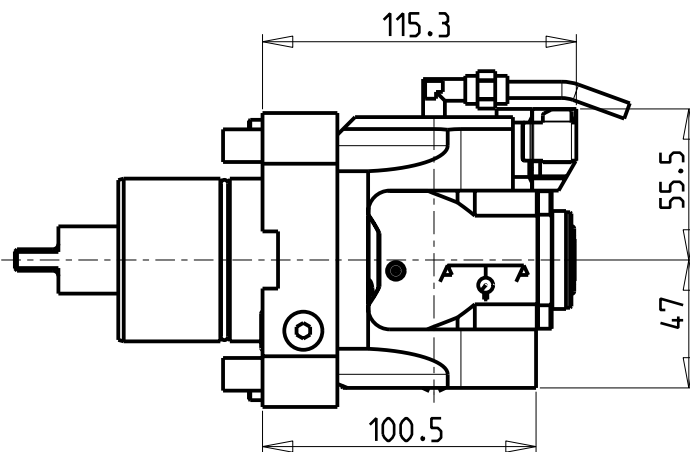
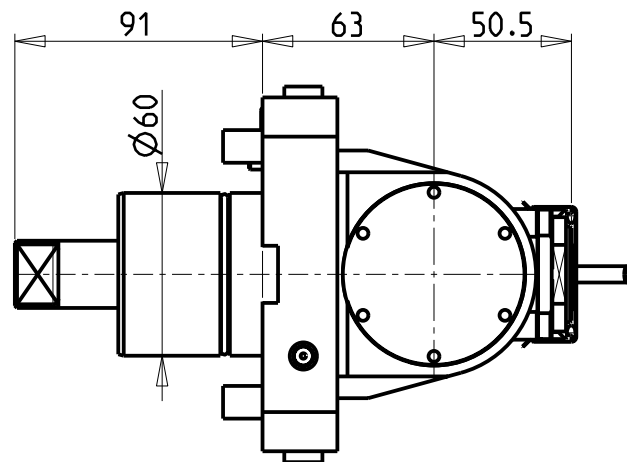
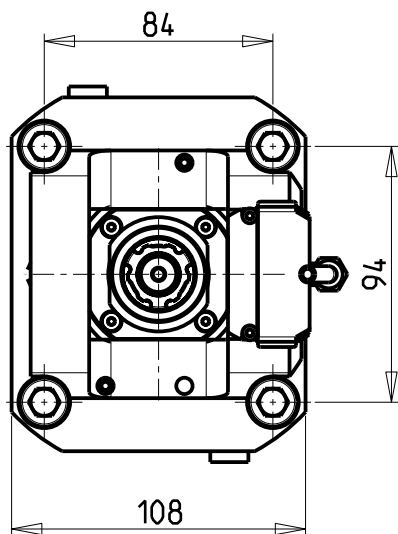

**ATTENZIONE - ATTENTION - ACHTUNG**

- Per lo smontaggio degli utensili utilizzare sempre la chiave di contrasto come indicato nel manuale d'uso.
- For disassembly of the tools use always the contrast key as mentioned in the user instructions.
- Fuer das Abmontieren der Werkzeuge immer den Gegenschlüssel benutzen wie in der Bedienungsanleitung erwaeht.

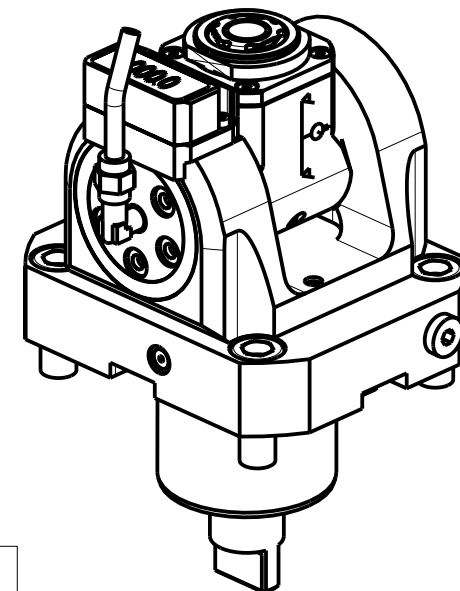

Cod. MT	Mandrino Spindle Spindel	I	RPM	Coppia Max Max Torque Max Drehmoment	Lubrificazione int. Coolant through Innenkuehlung	Lubrificazione est. Ext. coolant Aussenkuehlung	CHIAVI INCLUSE Keys included Schluessel inbegriffen			
MNL0645120	ERA20	1:1	6000	30Nm	-	X	CHUB22	CHUB36	CHTAER20ZC	CHESL10
MNL0645220	ERA20	1:1	6000	30Nm	P=70bar	X	CHUB22	CHUB36	CHTAER20ZC	CHESL10

MT RENT  
MT CUT T25Y/SY - MT CUT T32Y/SY

MODULO MOTORIZZATO ORIENTABILE +/-90° CON NONIO DIGITALE  
+/-90° adjustable angle driven tool with digital display  
Angetriebenes Werkzeug schwenkbar +/-90° mit digital display

Subject to change without notice.

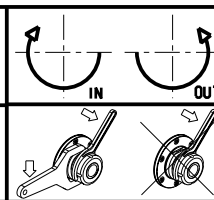

**M.T. srl**  
Via Casino Albini 480  
Tel. 0541/956034-957884  
Fax 0541/956341  
47842 S. GIOVANNI IN M. (RN)  
e-mail: mtma@mtmarchetti.com  
http://www.mtmarchetti.com

PRODUZIONE MODULI ROTANTI



PAGINA MTR335-1-01

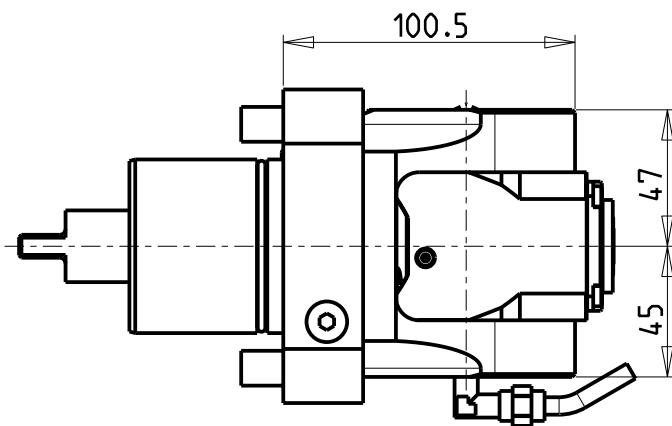
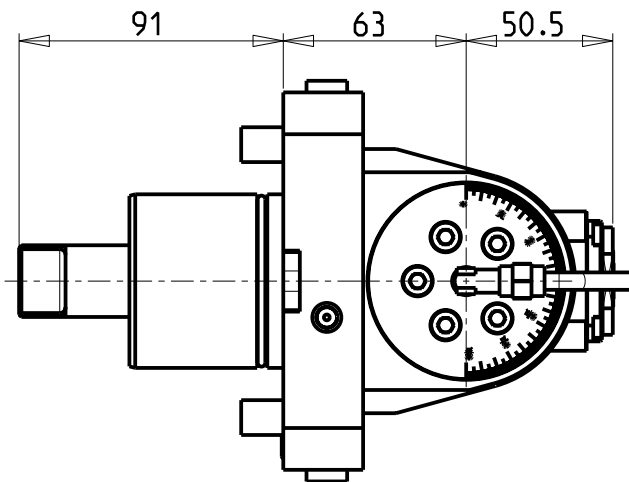
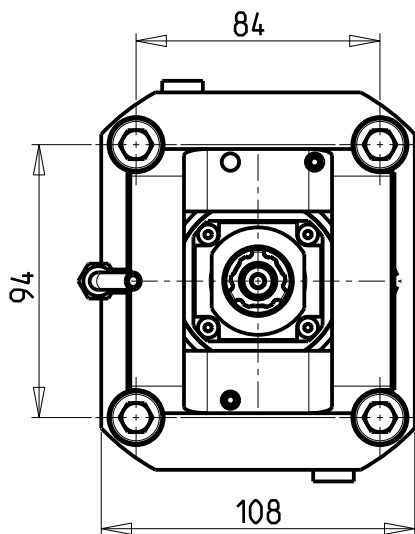

### ATTENZIONE - ATTENTION - ACHTUNG

- Per lo smontaggio degli utensili utilizzare sempre la chiave di contrasto come indicato nel manuale d'uso.
- For disassembly of the tools use always the contrast key as mentioned in the user instructions.
- Fuer das Abmontieren der Werkzeuge immer den Gegenschlüssel benutzen wie in der Bedienungsanleitung erwaeht.

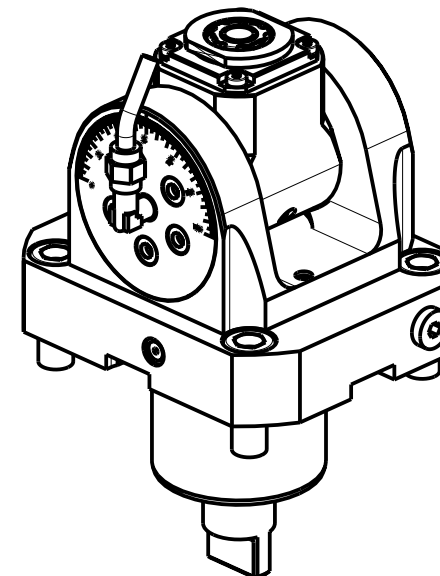

Cod. MT	Mandrino Spindle Spindel	I	RPM	Coppia Max Max Torque Max Drehmoment	Lubrificazione int. Coolant through Innenkuehlung	Lubrificazione est. Ext. coolant Aussenkuehlung	CHIAVI INCLUSE Keys included Schluessel inbegriffen			
							C HUB19_SP3	C HUB32	C HTAER16ZC	C HESL10
MNL0640316	ERA16	1:2	12000	8Nm		X	C HUB19_SP3	C HUB32	C HTAER16ZC	C HESL10
MNL0640416	ERA16	1:2	12000	8Nm	P=70bar	X	C HUB19_SP3	C HUB32	C HTAER16ZC	C HESL10

MT RENT  
MT CUT T25Y/SY - MT CUT T32Y/SY

MODULO MOTORIZZATO ORIENTABILE +/-90° MOLTIPLICATO I=1:2  
+/-90° adjustable angle driven tool geared-up I=1:2  
Angetriebenes Werkzeug schwenkbar +/-90° uebersetzt I=1:2

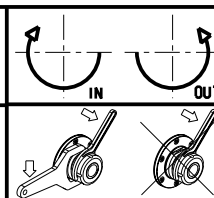

**M.T. srl**  
Via Casino Albini 480  
Tel. 0541/956034-957884  
Fax 0541/956341  
47842 S. GIOVANNI IN M. (RN)  
e-mail: mtma@mtmarchetti.com  
http://www.mtmarchetti.com

PRODUZIONE MODULI ROTANTI



PAGINA MTR336-1-00

Subject to change without notice.

10/2018



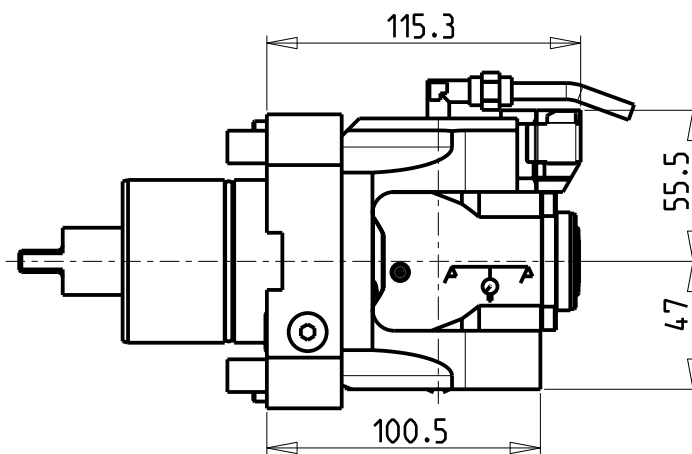
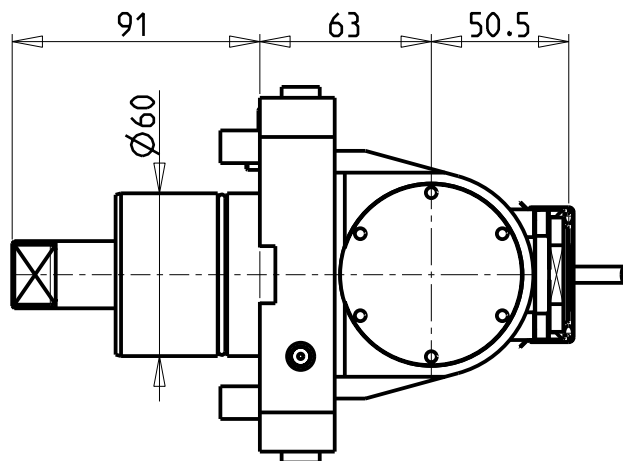
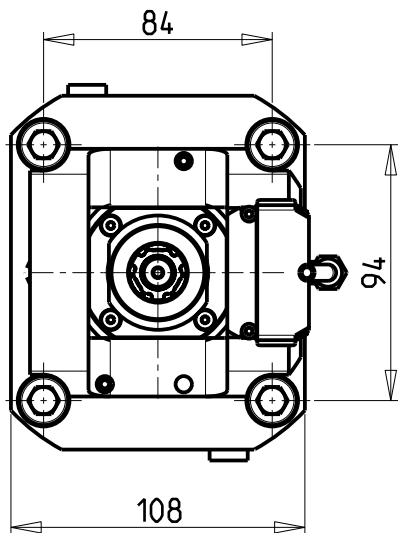

**ATTENZIONE - ATTENTION - ACHTUNG**

- Per lo smontaggio degli utensili utilizzare sempre la chiave di contrasto come indicato nel manuale d'uso.
- For disassembly of the tools use always the contrast key as mentioned in the user instructions.
- Fuer das Abmontieren der Werkzeuge immer den Gegenschlüssel benutzen wie in der Bedienungsanleitung erwäehnt.

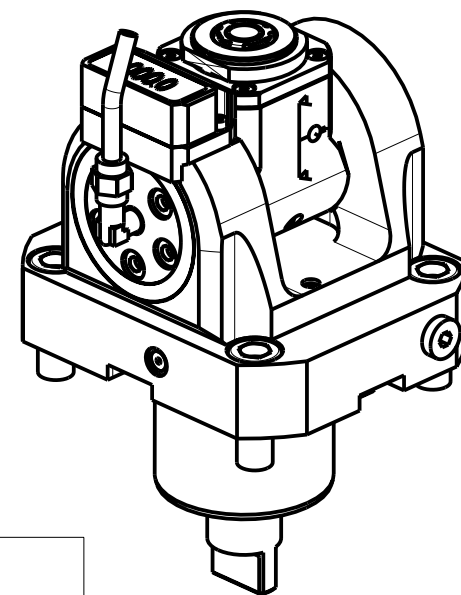

Cod. MT	Mandrino Spindle Spindel	I	RPM	Coppia Max Max Torque Max Drehmoment	Lubrificazione int. Coolant through Innenkuehlung	Lubrificazione est. Ext. coolant Aussenkuehlung	CHIAVI INCLUSE Keys included Schluessel inbegriffen			
MNL0645316	ERA16	1:2	12000	8Nm	-	X	CHUB19_SP3	CHUB32	CHTAER16ZC	CHESL10
MNL0645416	ERA16	1:2	12000	8Nm	P=70bar	X	CHUB19_SP3	CHUB32	CHTAER16ZC	CHESL10

**MT RENT**  
**MT CUT T25Y/SY - MT CUT T32Y/SY**

MODULO MOTORIZZATO ORIENTABILE +/-90° MOLTIPLICATO I=1:2 CON NONIO DIGITALE  
 +/-90° adjustable angle driven tool geared-up I=1:2 with digital display  
 Angetriebenes Werkzeug schwenkbar +/-90° uebersetzt I=1:2 mit digital display

Subject to change without notice.

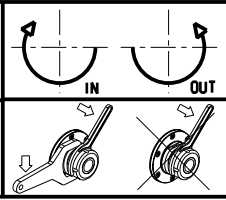

**M.T. srl**  
 Via Casino Albini 480  
 Tel. 0541/956034-957884  
 Fax 0541/956341  
 47842 S. GIOVANNI IN M. (RN)  
 e-mail: mtma@mtmarchetti.com  
 http://www.mtmarchetti.com

PRODUZIONE MODULI ROTANTI

PAGINA MTR336-1-01

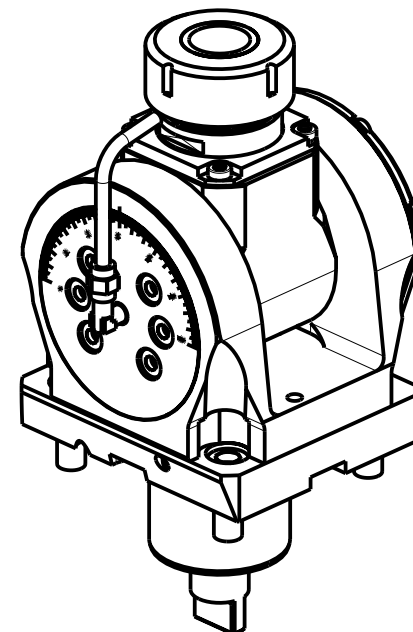
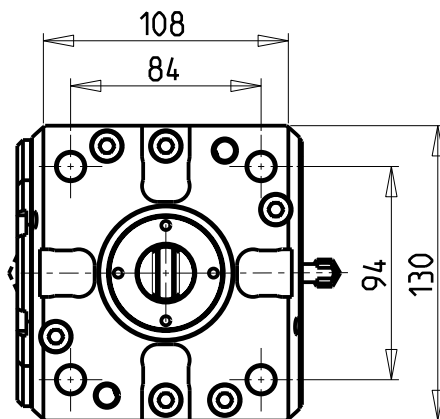
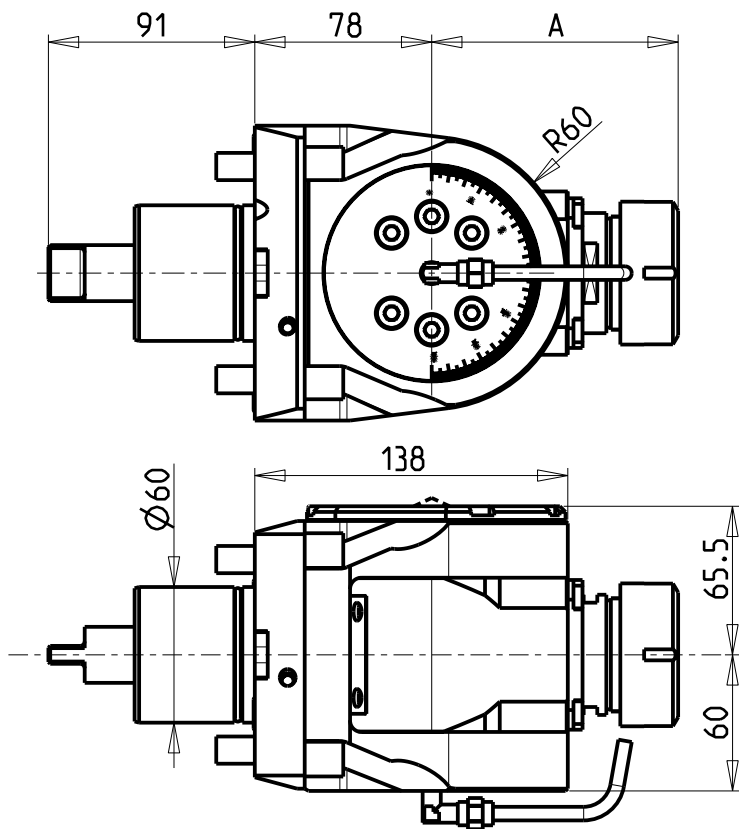

Cod. MT	Mandrino Spindle Spindel	I	RPM	Coppia Max Max Torque Max Drehmoment	Lubrificazione int. Coolant through Innenkuehlung	Lubrificazione est. Ext. coolant Aussenkuehlung	A	CHIAVI INCLUSE Keys included Schluessel inbegriffen				
								CHUB30	CHUB46	CHTAER32ZC	CHESL10	CHESL06
MNL0660332	ERA32	1:1	6000	50Nm		X	81	CHUB30	CHUB46	CHTAER32ZC	CHESL10	CHESL06
MNL0660432	ERA32	1:1	6000	50Nm	P=70bar	X	81	CHUB30	CHUB46	CHTAER32ZC	CHESL10	CHESL06
MNL0660140	ER40	1:1	6000	50Nm		X	108.66	-	CHUB46	CHSTER40	CHESL10	CHESL06
MNL0660240	ER40	1:1	6000	50Nm	P=70bar	X	108.66	-	CHUB46	CHSTER40	CHESL10	CHESL06

MT RENT  
MT CUT T25Y/SY - MT CUT T32Y/SY

MODULO MOTORIZZATO ORIENTABILE +/-90°  
+/-90° adjustable angle driven tool  
Angetriebenes Werkzeug schwenkbar +/-90°

Subject to change without notice.

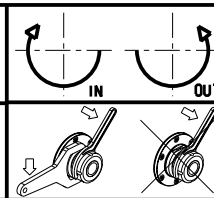

**M.T. srl**  
Via Casino Albini 480  
Tel. 0541/956034-957884  
Fax 0541/956341  
47842 S. GIOVANNI IN M. (RN)  
e-mail: mtma@mtmarchetti.com  
http://www.mtmarchetti.com

PRODUZIONE MODULI ROTANTI



PAGINA MTR339-1-00

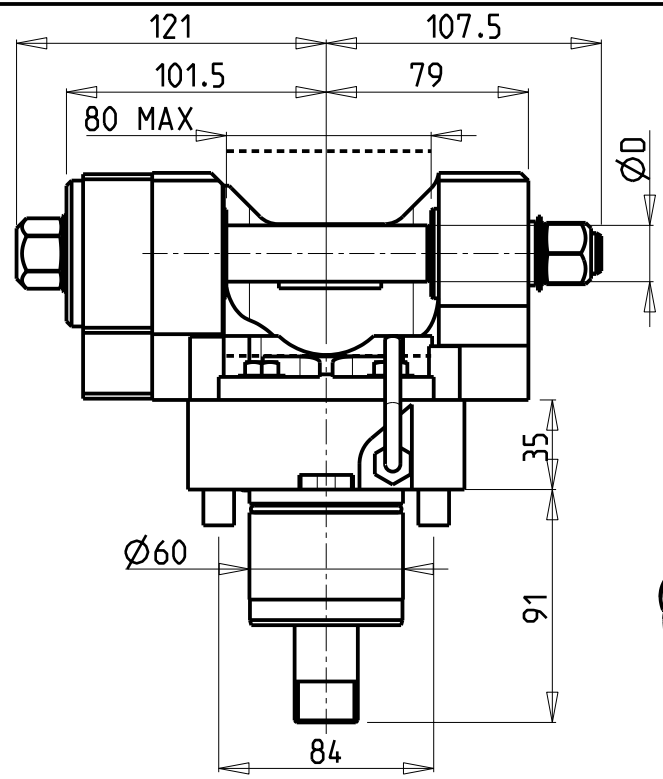
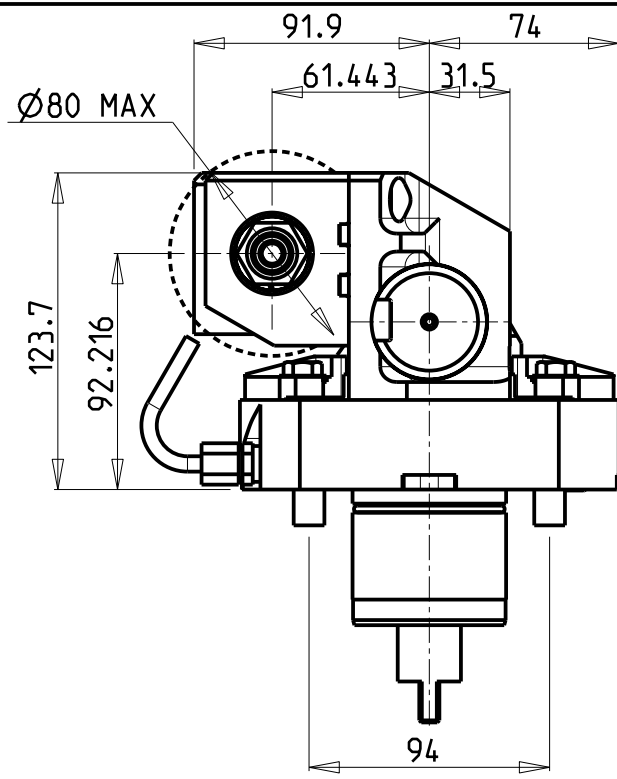

- SU RICHIESTA E' DISPONIBILE UNA STAFFA ANTIROTAZIONE PER LAVORAZIONI PESANTI
- On request we arrange antirotationscrew for heavy working
- Auf Anfrage verfuegen wir ueber Antirotationbolzen fuer schwere Verarbeitungen

INCLINAZIONE  
REGOLABILE ±20°

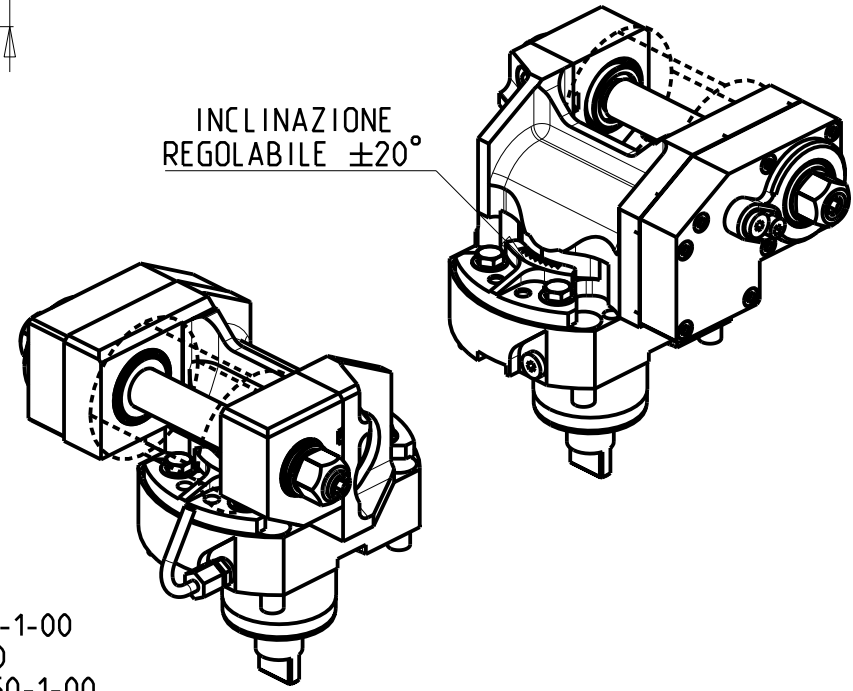

**DOTAZIONI - SUPPLIED WITH - AUSSTATTUNG**

- |           |   |
|-----------|---|
| mm / inch | - N°1 ALBERO + DISTANZIALI<br>- N°1 SHAFT + SPACER<br>- N°1 DORN + ABSTANDSSTUECK |
|-----------|---|

PER ALBERI E DISTANZIALI VEDI PAG. TBL250-1-00  
FOR SHAFT END SPACER SEE PAGE TBL250-1-00  
FUER DORN UND ABSTANDSSTUECK SEITE TBL250-1-00

Cod. MT	i	RPM max	Coppia Max Max Torque Max Drehmoment	Reversibile lato mandrino/contromandrino Reversible sub/main spindle side Umkehrbare Spindel-seite/ Gegenspindel-seite	Lubrificazione est. Ext. coolant Aussenkuehlung	D (mm)	D (Inch)	CHIAVI INCLUSE Keys included Schlüssel inbegriffen			
								CHUB24	CHUB13	CHESL08	CHESL10
MNL0151100	1:1	6000	60Nm	X	X	16-22-27-32	3/4"-1"-1 1/4"	CHUB24	CHUB13	CHESL08	CHESL10
MNL0152100	2:1	3000	80Nm	X	X	16-22-27-32	3/4"-1"-1 1/4"	CHUB24	CHUB13	CHESL08	CHESL10

MT RENT  
MT CUT T25Y/SY - MT CUT T32Y/SY

MODULO MOTORIZZATO PORTACREATORE  
Driven gear hobber  
Angetriebenes Zahnradwaeltzraes-Werkzeug

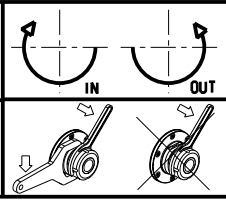

**M.T. srl**  
Via Casino Albini 480  
Tel. 0541/956034-957884  
Fax 0541/956341  
47842 S. GIOVANNI IN M. (RN)  
e-mail: mtma@tmarchetti.com  
http://www.tmmarchetti.com

PRODUZIONE MODULI ROTANTI



PAGINA MTR340-1-00

Subject to change without notice.

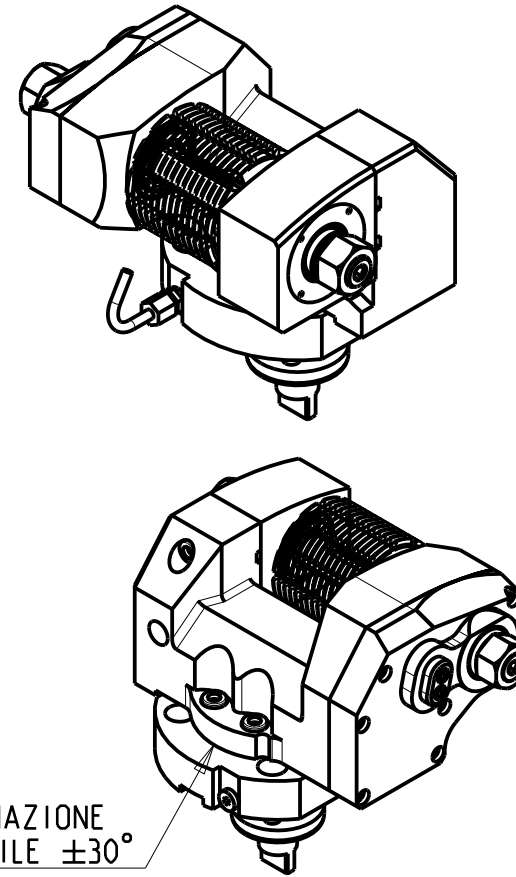
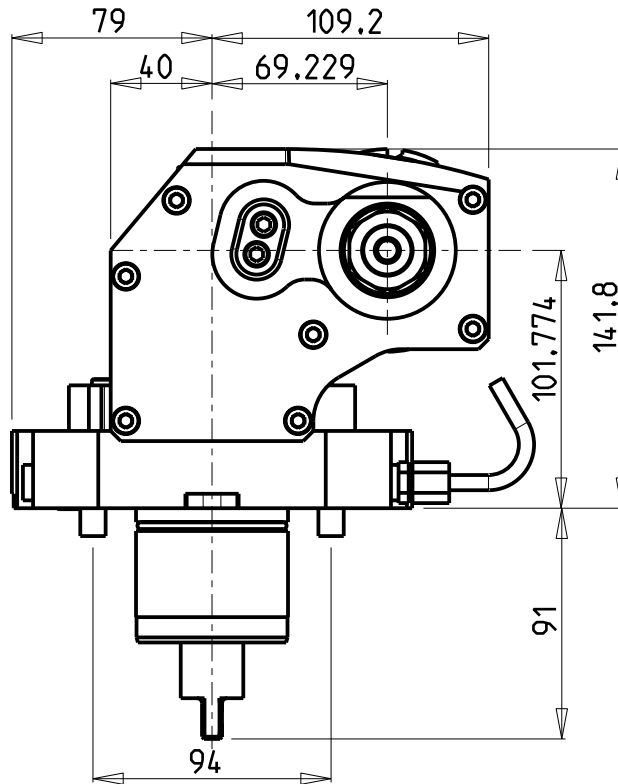
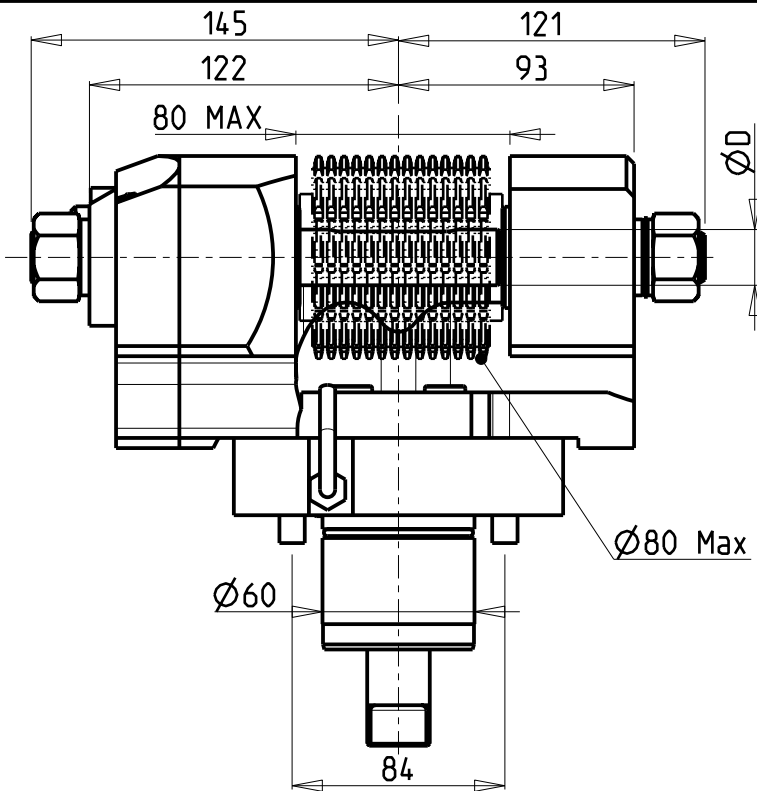

INCLINAZIONE  
REGOLABILE  $\pm 30^\circ$

**DOTAZIONI - SUPPLIED WITH - AUSSTATTUNG**

- | mm / inch |                             |
|-----------|-----------------------------|
|           | - N°1 ALBERO + DISTANZIALI  |
|           | - N°1 SHAFT + SPACER        |
|           | - N°1 DORN + ABSTANDSSTUECK |

PER ALBERI E DISTANZIALI VEDI PAG. TBL250-1-00  
FOR SHAFT END SPACER SEE PAGE TBL250-1-00  
FUER DORN UND ABSTANDSSTUECK SEITE TBL250-1-00

Cod. MT	i	RPM max	Coppia Max Max Torque Max Drehmoment	Lubrificazione est. Ext. coolant Aussenkuehlung	D (mm)	D (Inch)	CHIAVI INCLUSE Keys included Schluessel inbegriffen			
							CHUB30	CHESL08	CHESL10	CHUB24 (Ø16 / Ø3/4")
MNL0411100	1:1	6000	90Nm	X	16-22-27-32	3/4"-1"-1 1/4"	CHUB30	CHESL08	CHESL10	CHUB24 (Ø16 / Ø3/4")
MNL0412100	2:1	3000	110Nm	X	16-22-27-32	3/4"-1"-1 1/4"	CHUB30	CHESL08	CHESL10	CHUB24 (Ø16 / Ø3/4")

**MT RENT**

MT CUT T25Y/SY - MT CUT T32Y/SY

MODULO MOTORIZZATO PORTACREATORE MAGGIORATO

Reinforced driven gear hobber

Angetriebenes Zahnradwaelzfraes-Werkzeug vergroessert

Subject to change without notice.

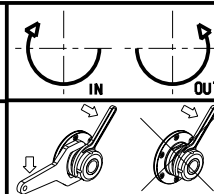

**M.T. srl**

Via Casino Albini 480  
Tel. 0541/956034-957884  
Fax 0541/956341  
47842 S. GIOVANNI IN M. (RN)  
e-mail: mtma@mtmarchetti.com  
http://www.mtmarchetti.com

PRODUZIONE MODULI ROTANTI



PAGINA MTR340-1-60

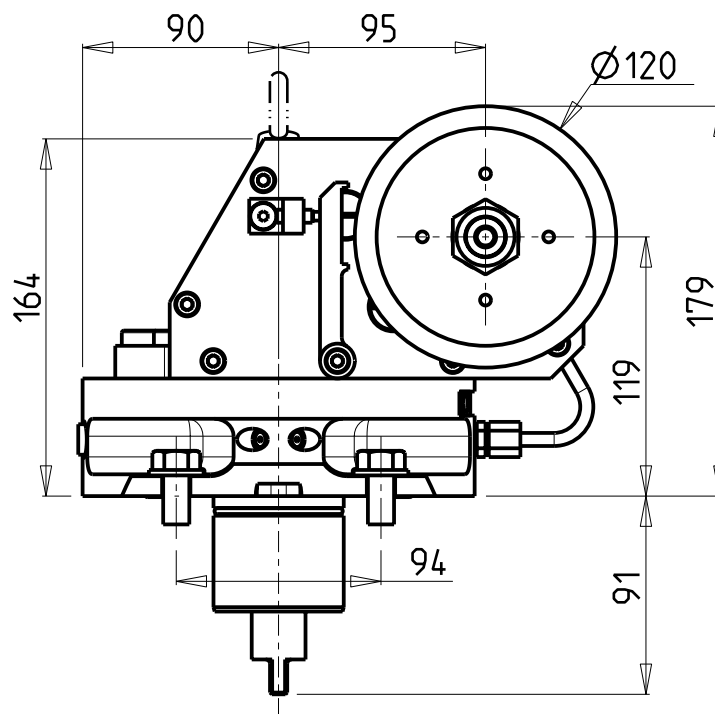
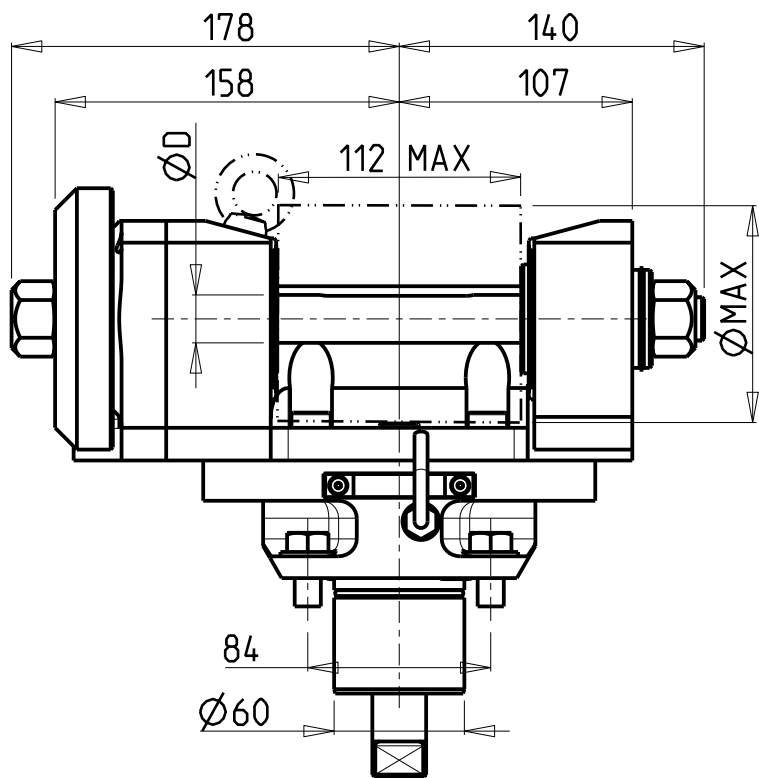

D (mm)	ØMAX (mm)
22	89
27-32	100

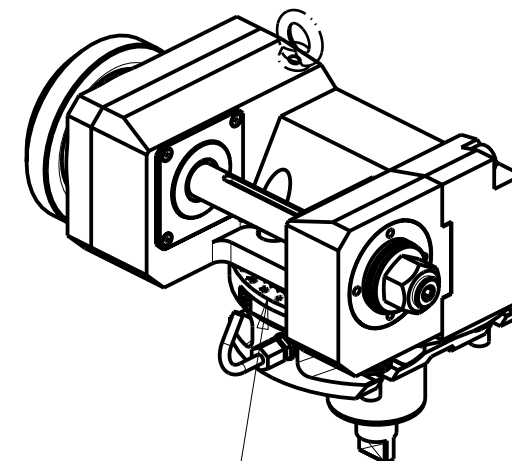

INCLINAZIONE  
REGOLABILE ±180°

**DOTAZIONI - SUPPLIED WITH - AUSSTATTUNG**

- | mm / inch |                             |
|-----------|-----------------------------|
|           | - N°1 ALBERO + DISTANZIALI  |
|           | - N°1 SHAFT + SPACER        |
|           | - N°1 DORN + ABSTANDSSTUECK |

PER ALBERI E DISTANZIALI VEDI PAG. TBL250-1-00  
FOR SHAFT END SPACER SEE PAGE TBL250-1-00  
FUER DORN UND ABSTANDSSTUECK SEITE TBL250-1-00

Cod. MT	i	RPM max	Coppia Max Max Torque Max Drehmoment	Lubrificazione est. Ext. coolant Aussenkuehlung	D (mm)	CHIAVI INCLUSE Keys included Schluessel inbegriffen			
						CHUB30	CHESL08	CHESL10	CHUB19
MNL0671100	1:1	6000	110Nm	X	22-27-32	CHUB30	CHESL08	CHESL10	CHUB19
MNL0672100	2:1	3000	130Nm	X	22-27-32	CHUB30	CHESL08	CHESL10	CHUB19

MT RENT

MT CUT T25Y/SY - MT CUT T32Y/SY

MODULO MOTORIZZATO PORTACREATORE (TAGLIA GRANDE)

Driven gear hobber (big size)

Angetriebenes Zahnradwaeltzraes-Werkzeug (grosse version)

Subject to change without notice.

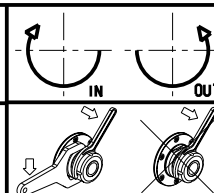

**M.T. srl**

Via Casino Albini 480  
Tel. 0541/956034-957884  
Fax 0541/956341  
47842 S. GIOVANNI IN M. (RN)  
e-mail: mtma@mtmarchetti.com  
http://www.mtmarchetti.com

PRODUZIONE MODULI ROTANTI



PAGINA MTR340-1-80

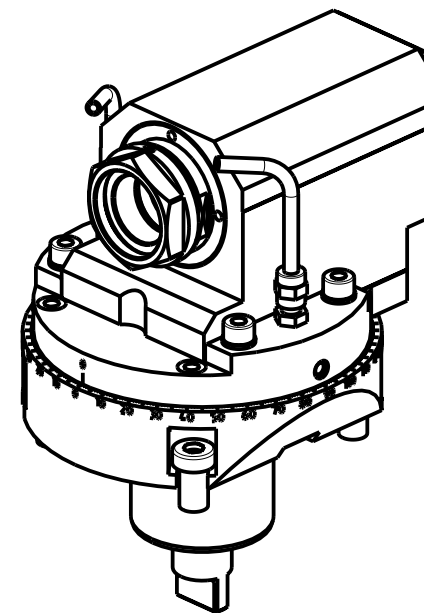
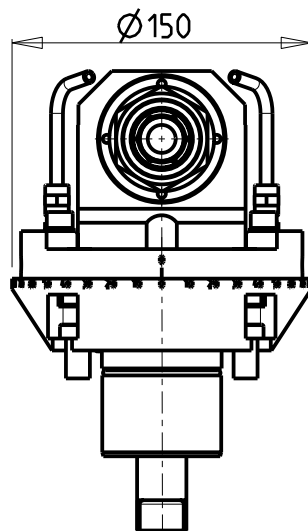
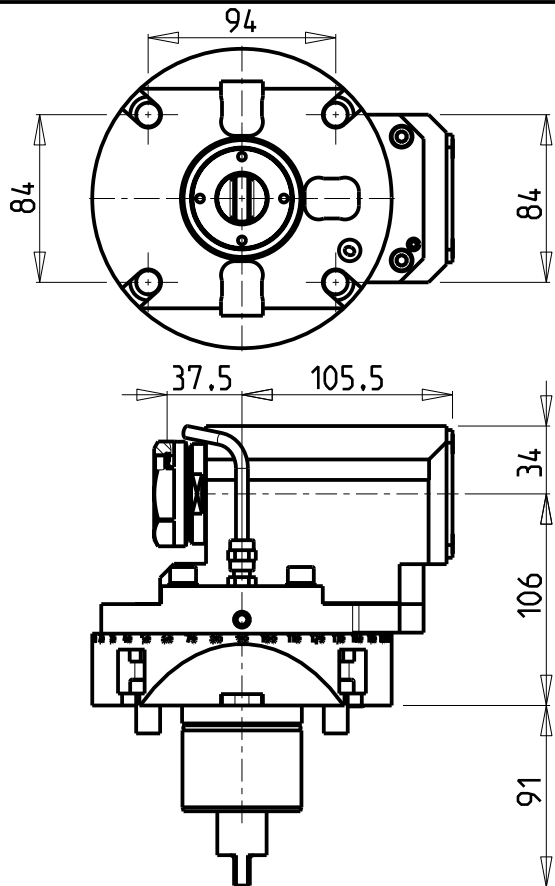

**ATTENZIONE - ATTENTION - ACHTUNG**

- VERIFICARE LE MISURE DI INGOMBRO PER POSSIBILE INTERFERENZA SU ALCUNI MODELLI DI MACCHINE
- Please check the overall sizes for possible interferences on some machine models
- Bitte überprüfen sie das ausmass um mögliche interferenzen auf einigen maschinen modellen zu vermeiden

PER PORTAUTENSILI MODULARI MTSK-40 VEDI PAG. TBL300-1-40  
 FOR MTSK-40 QUICK CHANGE TOOLHOLDERS CLAMPINGS SEE PAGE TBL300-1-40  
 FUER MTSK-40 MODULARE WERKZEUGAUFNAHMEN SIEHE SEITE TBL300-1-40

Cod. MT	Mandrino Spindle Spindel	I	RPM	Coppia Max Max Torque Max Drehmoment	Lubr.esterna Ext. coolant Aussenkuehlung	CHIAVI INCLUSE Keys included Schluessel einbegriffen
MNL0870100	MTSK-40	1:1	6000	50Nm	X	n°2 CHUB46

MT RENT  
 MT CUT T25Y/SY - MT CUT T32Y/SY

MODULO MOTORIZZATO ASSIALE MTSK PER POWER SKIVING H=106mm  
 Axial MTSK driven tool for Power Skiving H=106mm  
 Axial MTSK angetriebenes Werkzeug fuer Power Skiving H=106mm

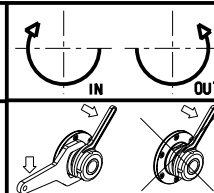

**M.T. srl**  
 Via Casino Albini 480  
 Tel. 0541/956034-957884  
 Fax 0541/956341  
 47842 S. GIOVANNI IN M. (RN)  
 e-mail: mtma@mtmarchetti.com  
 http://www.mtmarchetti.com

PRODUZIONE MODULI ROTANTI



PAGINA MTR350-1-00-K

Subject to change without notice.

10/2018

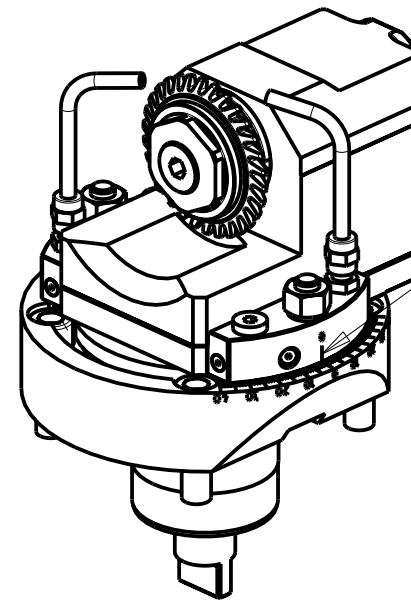
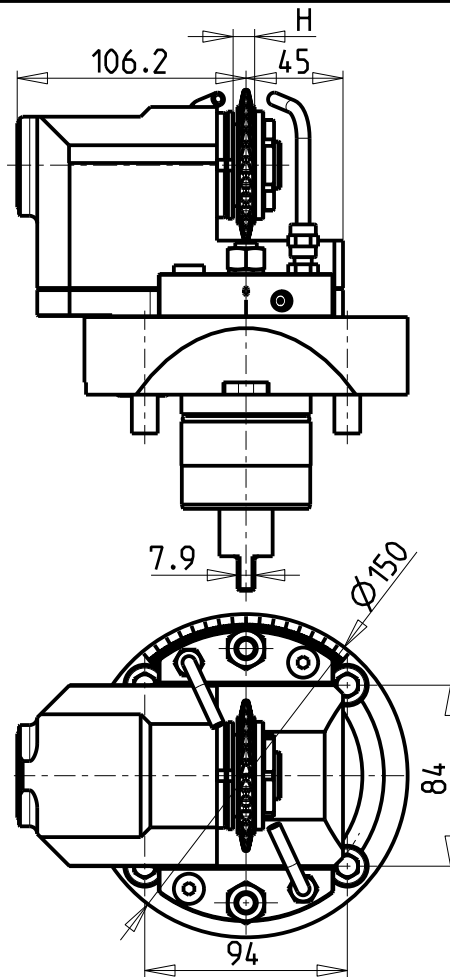
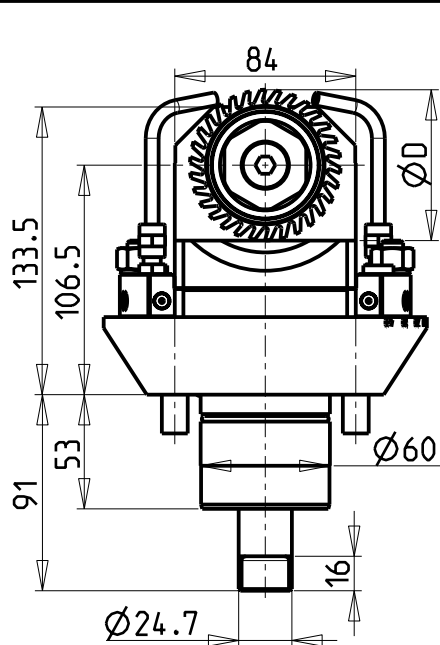

INCLINAZIONE  
REGOLABILE ±31°

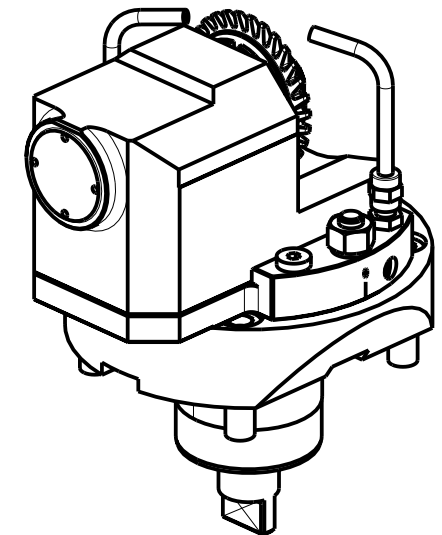

Cod. MT	Mandrino Spindle Spindel	I	RPM	Coppia Max Max Torque Max Drehmoment	Lubrificazione est. Ext. coolant Auslenkung	ØD	H	CHIAVI INCLUSE Keys included Schlüssel einbegriffen			
MNL0378022	Ø22x12	1:1	6000	50Nm	X	63-70-80	MAX 12	CHUB38	CHUB17	CHESL10	CHESL08
MNL0378125	Ø1"x12	1:1	6000	50Nm	X	63-70-80	MAX 12	CHUB38	CHUB17	CHESL10	CHESL08

MT RENT  
MT CUT T25Y/SY - MT CUT T32Y/SY

MODULO MOTORIZZATO PER VITI SENZA FINE  
Driven tool for worm screws  
Angetriebenes Werkzeug fuer schrauben ohne ende

Subject to change without notice.

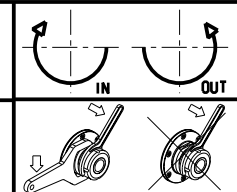

**M.T. srl**  
Via Casino Albini 480  
Tel. 0541/956034-957884  
Fax 0541/956341  
47842 S. GIOVANNI IN M. (RN)  
e-mail: mtma@mtmarchetti.com  
http://www.mtmarchetti.com

PRODUZIONE MODULI ROTANTI



PAGINA MTR359-1-00

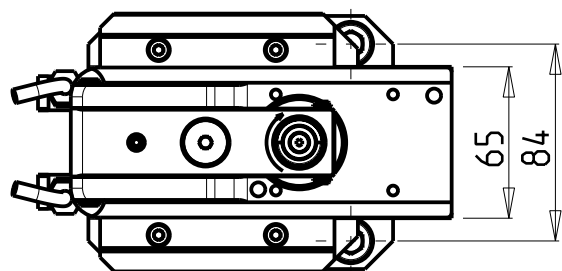
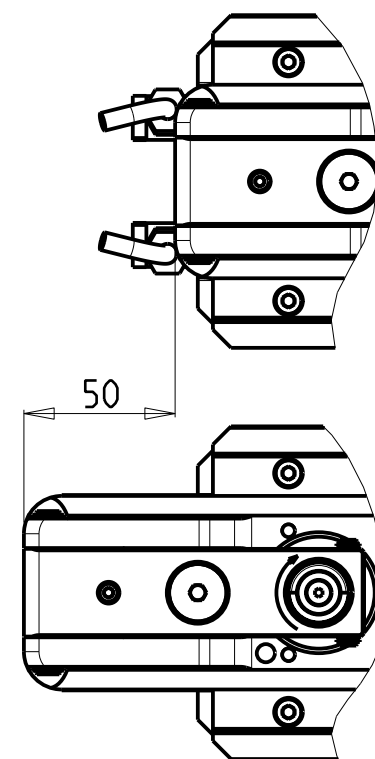
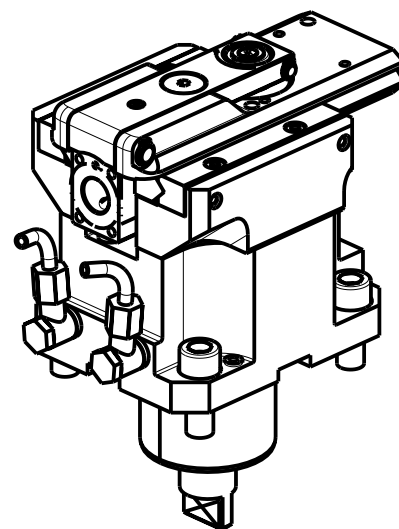
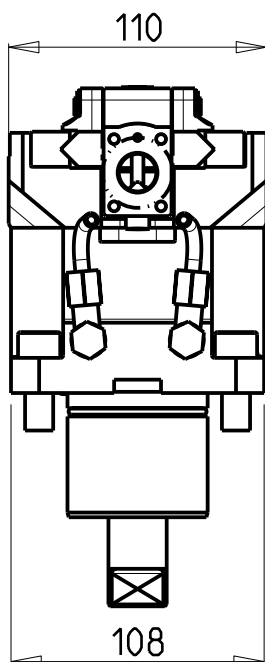
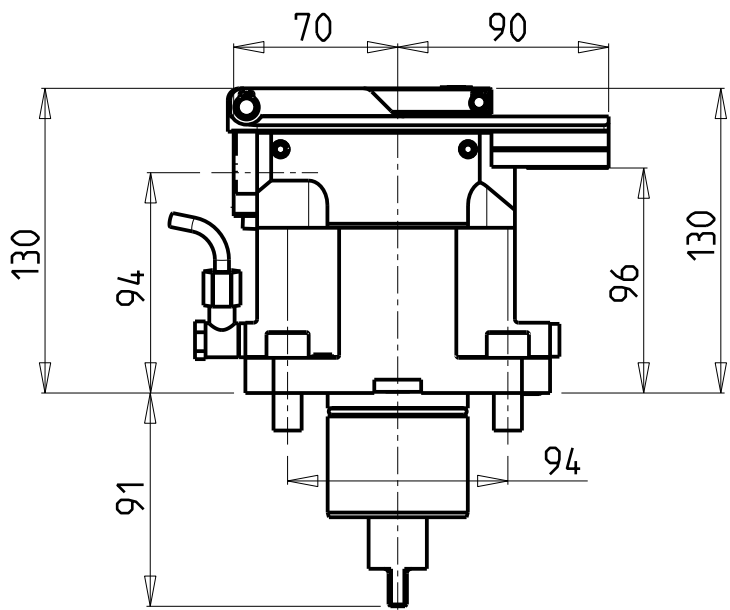

PER UTENSILI STOZZATORI VEDI PAG. TBL400-1-00  
 FOR DRIVEN SLOTTING TOOL CUTTING-TOOLS SEE PAGE TBL400-1-00  
 FÜR NUTENSTOSS-WERKZEUG SCHNEIDWERKZEUGE SIEHE SEITE TBL400-1-00

Cod. MT	I	RPM MAX	Reversibile lato mandrino/contromandrino Reversible sub/main spindle side Umkehrbare Spindelseite/ Gegenspindelseite	Lubr. esterna Ext. coolant Aussenkuehlung
MNL0650100	4:1	2000	X	X

MT RENT  
 MT CUT T25Y/SY - MT CUT T32Y/SY

MODULO MOTORIZZATO STOZZATORE CORSA 50mm H=94mm  
 Slotting driven tool 50mm stroke H=94mm  
 Keilnutenstossmaschine 50mm Hub H=94mm

Subject to change without notice.

**M.T. srl**  
 Via Casino Albini 480  
 Tel. 0541/956034-957884  
 Fax 0541/956341  
 47842 S. GIOVANNI IN M. (RN)  
 e-mail: mtma@mtmarchetti.com  
 http://www.mtmarchetti.com

PRODUZIONE MODULI ROTANTI



PAGINA MTR360-1-00



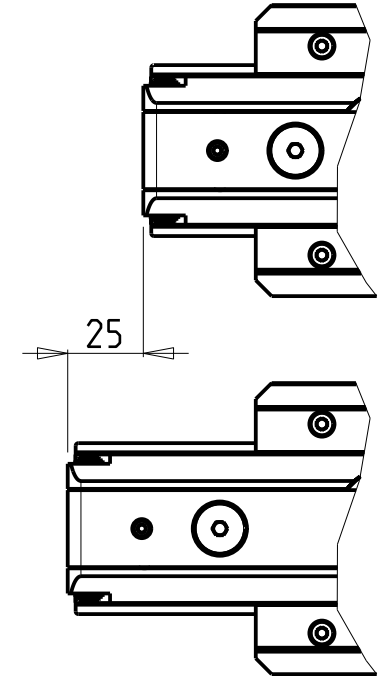
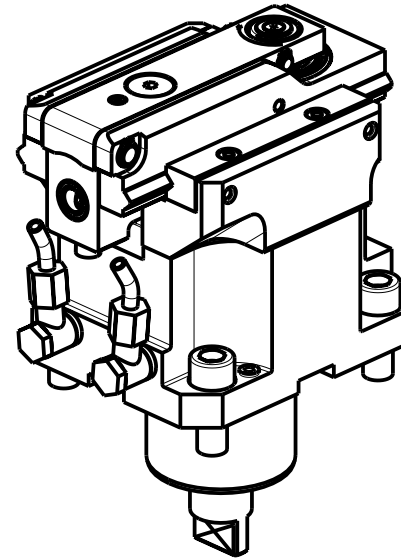
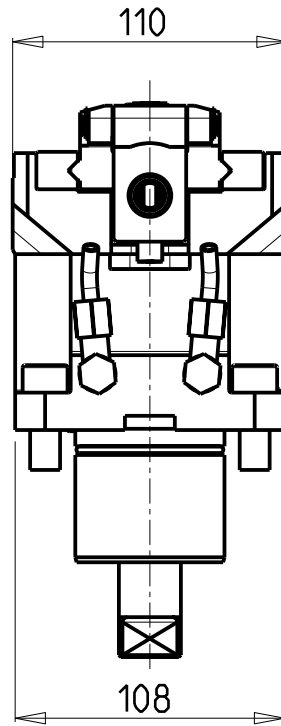
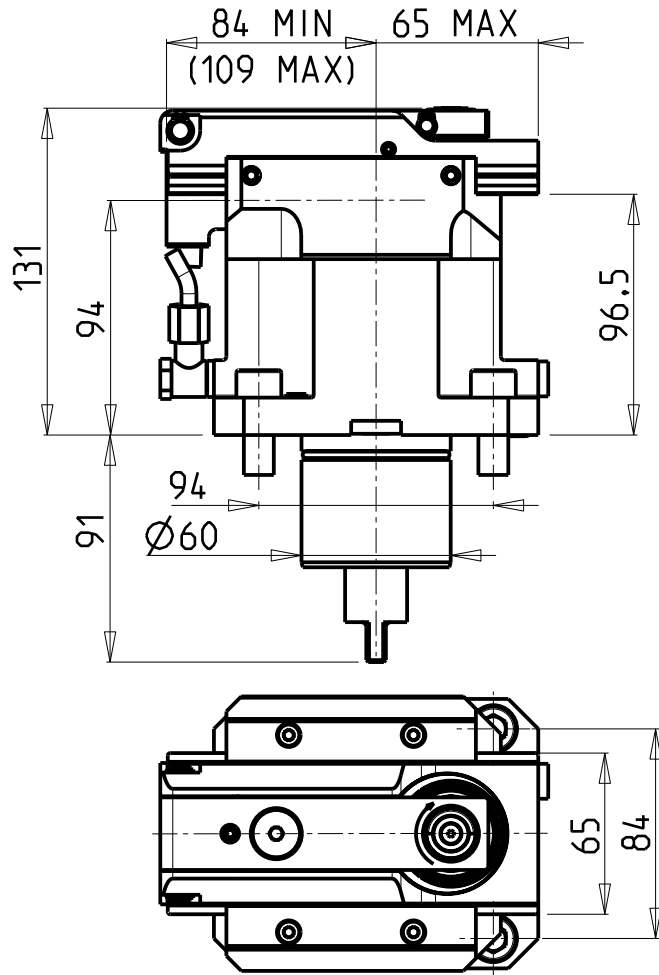

PER UTENSILI STOZZATORI VEDI PAG. TBL400-1-00  
 FOR DRIVEN SLOTTING TOOL CUTTING-TOOLS SEE PAGE TBL400-1-00  
 FÜR NUTENSTOSS-WERKZEUG SCHNEIDWERKZEUGE SIEHE SEITE TBL400-1-00

Cod. MT	I	RPM MAX	Reversibile lato mandrino/contromandrino Reversible sub/main spindle side Umkehrbare Spindelseite/ Gegenspindelseite	Lubr. esterna Ext. coolant Aussenkuehlung
MNL0650200	4:1	2400	X	X

MT RENT

MT CUT T25Y/SY - MT CUT T32Y/SY

MODULO MOTORIZZATO STOZZATORE CORSA 25mm H=94mm

Slotting driven tool 25mm stroke H=94mm

Keilnutenstossmaschine 25mm Hub H=94mm

Subject to change without notice.

**M.T. srl**

Via Casino Albini 480  
 Tel. 0541/956034-957884  
 Fax 0541/956341  
 47842 S. GIOVANNI IN M. (RN)  
 e-mail: mtma@mtmarchetti.com  
 http://www.mtmarchetti.com

PRODUZIONE MODULI ROTANTI



PAGINA MTR360-1-01

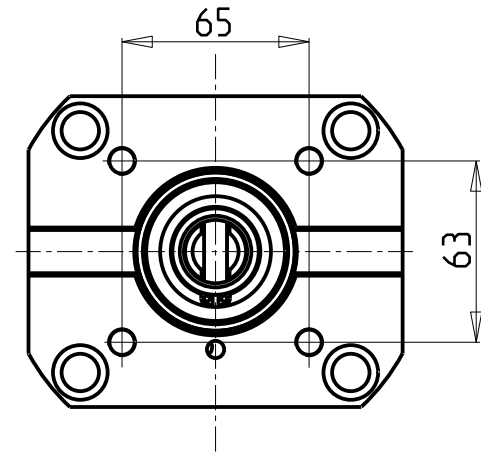
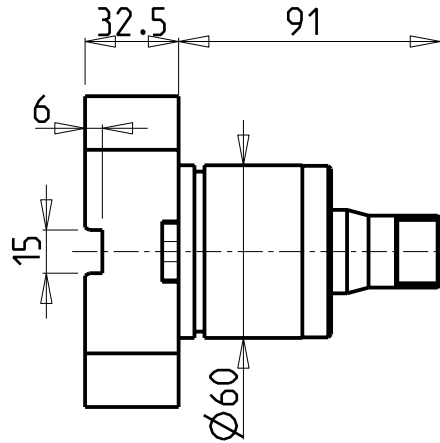
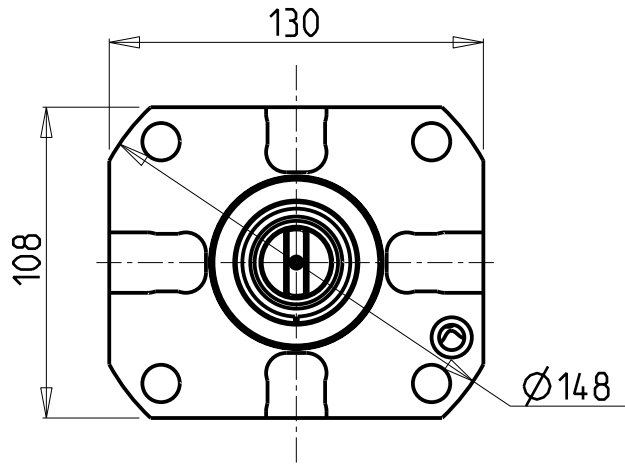
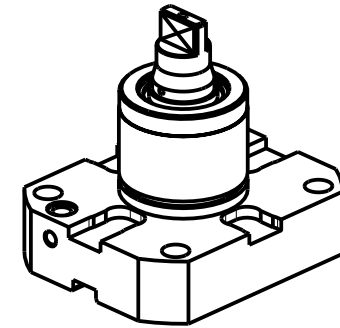
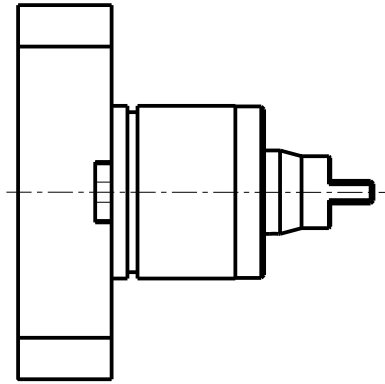
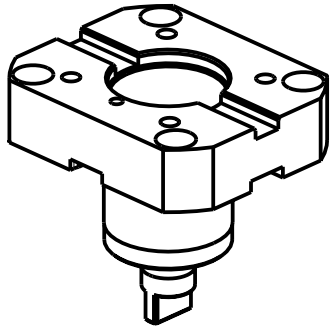

Cod. MT

MNL0246055

MT RENT  
MT CUT T25Y/SY - MT CUT T32Y/SY

INTERFACCIA PER MODULI BIGLIA  
Biglia tooling adapter cartridge  
Adapter-Patrone fuer Biglia Werkzeuge

Subject to change without notice.

**M.T. srl**

Via Casino Albini 480  
Tel. 0541/956034-957884  
Fax 0541/956341  
47842 S. GIOVANNI IN M. (RN)  
e-mail: mtma@mtmarchetti.com  
<http://www.mtmarchetti.com>

PRODUZIONE MODULI ROTANTI



PAGINA MTR380-1-00

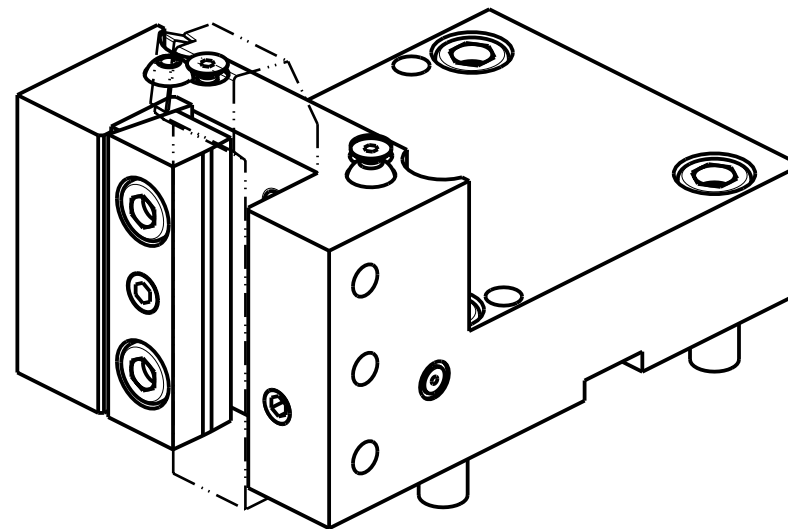
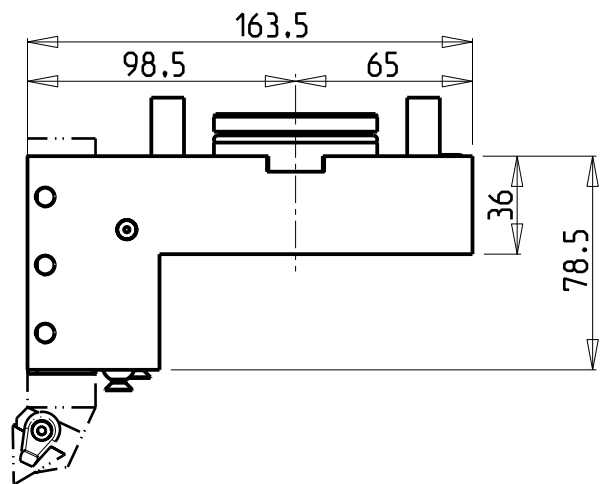
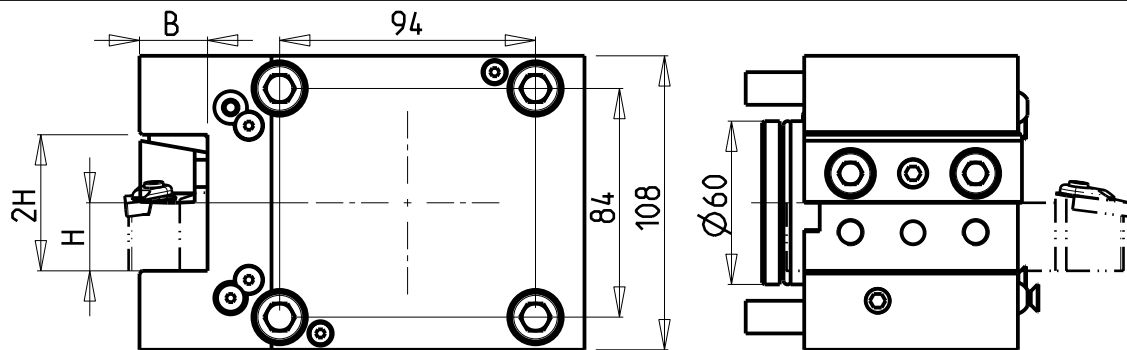

Cod. MT	N°Utensili N°Tools N°Werkzeuge	Reversibile lato mandrino/contromandrino Reversible sub/main spindle side Umkehrbare Spindel-seite/ Gegenspindel-seite	Misure Dimensions Masse	B	H
MNL0042500	1/2	X	mm	25	25
MNL0042540	1/2	X	Inch	1"	1"
MNL0042000	1/2	X	mm	20	20
MNL0041905	1/2	X	Inch	3/4"	3/4"

MT RENT

MT CUT T25Y/SY - MT CUT T32Y/SY

PORTAUTENSILE RADIALE SINGOLO QD=25mm / QD=1" / QD=20mm / QD=3/4"

Radial single static tool QD=25mm / QD=1" / QD=20mm / QD=3/4"

Radial Single-Werkzeughalter QD=25mm / QD=1" / QD=20mm / QD=3/4"

Subject to change without notice.

**M.T. srl**

Via Casino Albini 480  
Tel. 0541/956034-957884  
Fax 0541/956341

47842 S. GIOVANNI IN M. (RN)  
e-mail: mtma@tmarchetti.com  
http://www.tmmarchetti.com

PRODUZIONE MODULI ROTANTI



PAGINA MTR423-1-00

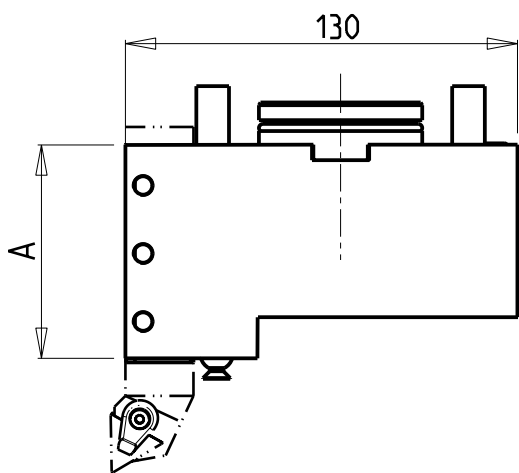
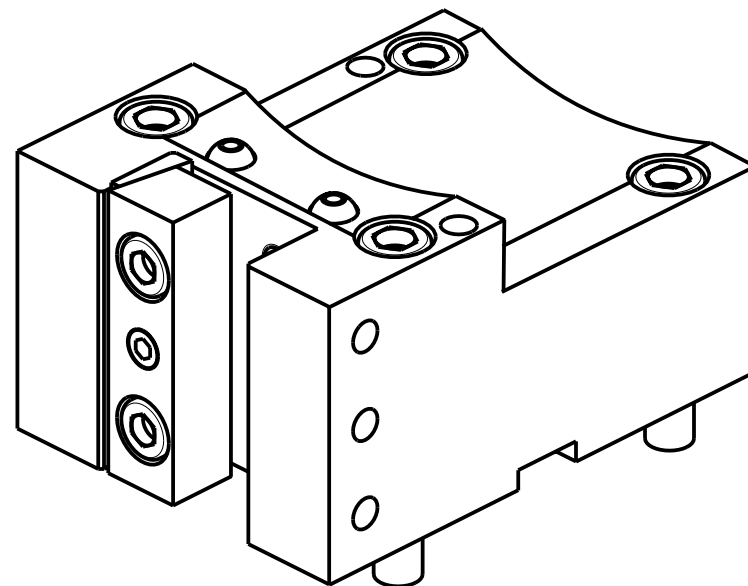
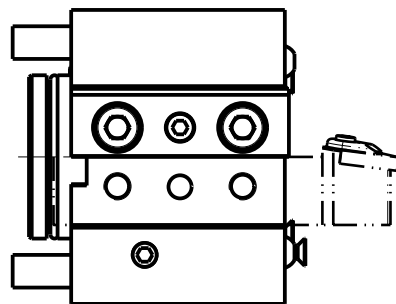
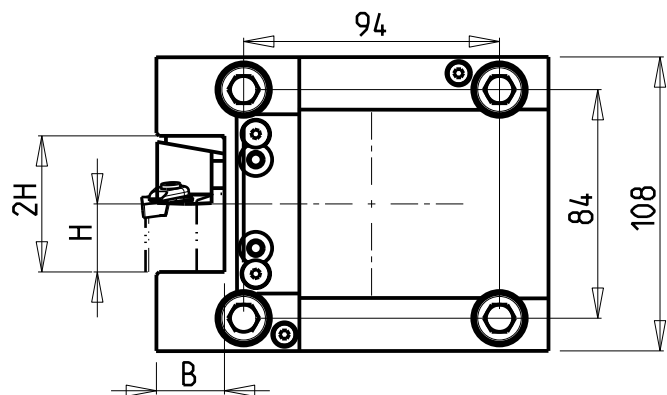

Cod. MT	N°Utensili N°Tools N°Werkzeuge	Reversibile lato mandrino/contromandrino Reversible sub/main spindle side Umkehrbare Spindel-seite/ Gegenspindel-seite	Misure Dimensions Masse	A	B	H
MNL0042500_CH	1/2	X	mm	70	25	25
MNL0042000_CH	1/2	X	mm	65	20	20

MT RENT

MT CUT T25Y/SY - MT CUT T32Y/SY

PORTAUTENSILE RADIALE SINGOLO QD=25mm / QD=20mm

Radial single static tool QD=25mm / QD=20mm

Radial Single-Werkzeughalter QD=25mm / QD=20mm

Subject to change without notice.

**M.T. srl**

Via Casino Albini 480  
Tel. 0541/956034-957884

Fax 0541/956341

47842 S. GIOVANNI IN M. (RN)

e-mail: [mtma@mtmarchetti.com](mailto:mtma@mtmarchetti.com)  
<http://www.mtmarchetti.com>

PRODUZIONE MODULI ROTANTI



PAGINA MTR424-1-00

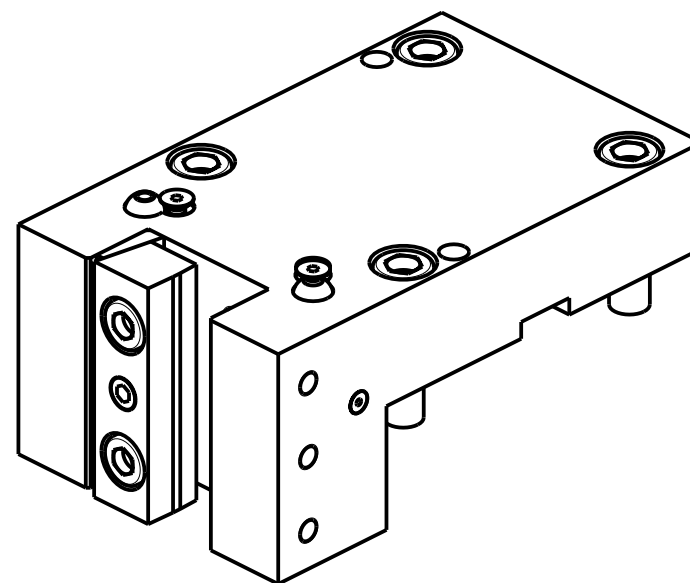
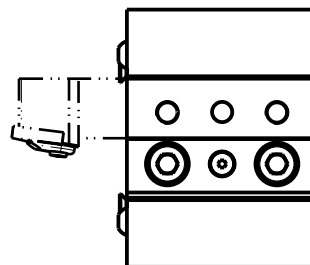
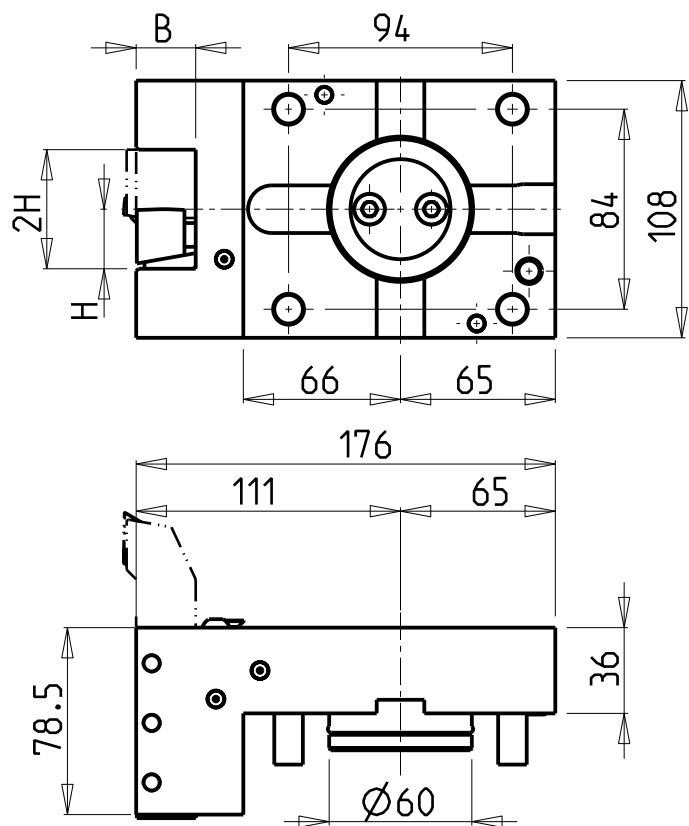

Cod. MT	N°Utensili N° Tools N° Werkzeuge	Misure Dimensions Masse	B	H
MNL0382500	1/2	mm	25	25
MNL0382540	1/2	Inch	1"	1"
MNL0382000	1/2	mm	20	20
MNL0381905	1/2	Inch	3/4"	3/4"

MT RENT  
MT CUT T25Y/SY - MT CUT T32Y/SY

PORTAUTENSILE RADIALE SINGOLO ARRETRATO QD=25mm / QD=1" / QD=20mm / QD=3/4"  
Radial rear-set single static tool QD=25mm / QD=1" / QD=20mm / QD=3/4"  
Radial Single-Werkzeughalter zurueckversetzt QD=25mm / QD=1" / QD=20mm / QD=3/4"

Subject to change without notice.

**M.T. srl**

Via Casino Albini 480  
Tel. 0541/956034-957884  
Fax 0541/956341  
47842 S. GIOVANNI IN M. (RN)  
e-mail: mtma@mtmarchetti.com  
http://www.mtmarchetti.com

PRODUZIONE MODULI ROTANTI



PAGINA MTR433-1-00

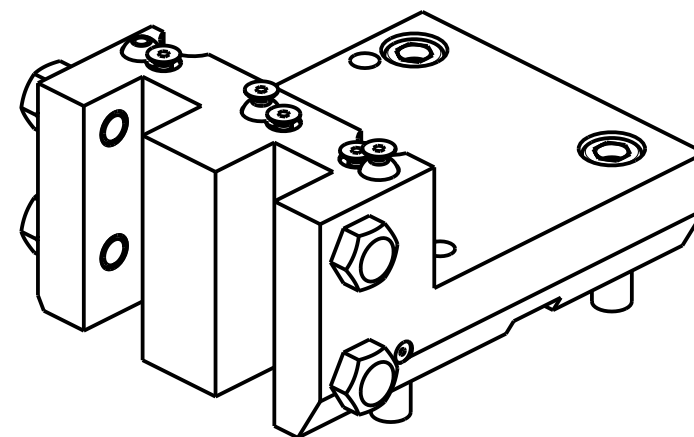
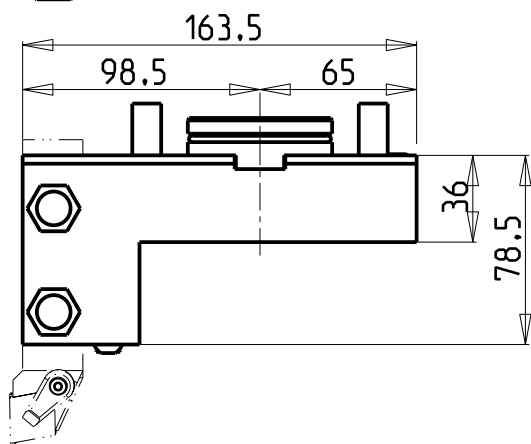
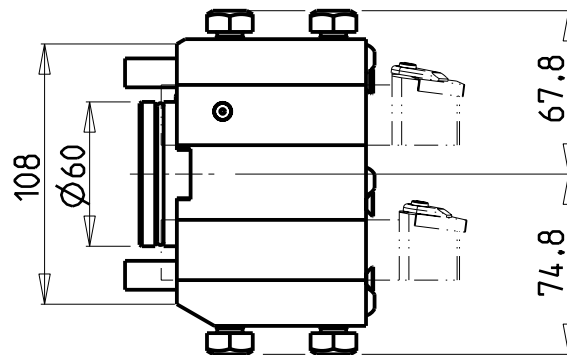
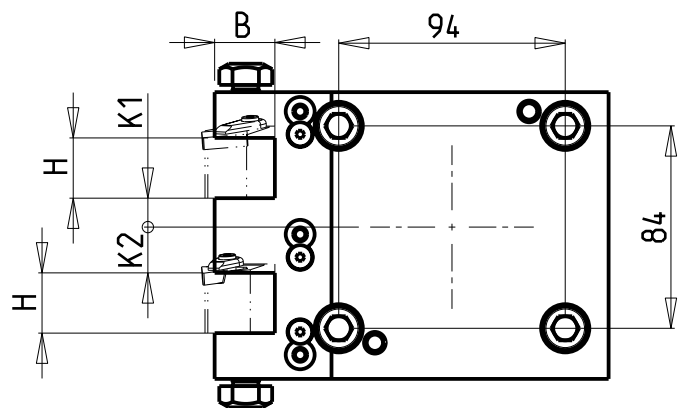

Cod. MT	N°Utensili N°Tools N°Werkzeuge	Reversibile lato mandrino/contromandrino Reversible sub/main spindle side Umkehrbare Spindelseite/ Gegenspindelseite	Misure Dimensions Masse	H	B	K1	K2
MNL0062500	2	X	mm	25	25	12	19
MNL0062540	2	X	Inch	1"	1"	1/2"	3/4"
MNL0062000	2	X	mm	20	20	12	19
MNL0061905	2	X	Inch	3/4"	3/4"	1/2"	3/4"

MT RENT  
MT CUT T25Y/SY - MT CUT T32Y/SY

PORTAUTENSILE RADIALE SOVRAPPOSTO QD=25mm / QD=1" / QD=20mm / QD=3/4"  
Radial single side twin static tool QD=25mm / QD=1" / QD=20mm / QD=3/4"  
Radial Werkzeughalter ueberlagert QD=25mm / QD=1" / QD=20mm / QD=3/4"

Subject to change without notice.

**M.T. srl**

Via Casino Albini 480  
Tel. 0541/956034-957884  
Fax 0541/956341  
47842 S. GIOVANNI IN M. (RN)  
e-mail: mtma@tmarchetti.com  
http://www.tmmarchetti.com

PRODUZIONE MODULI ROTANTI



PAGINA MTR442-1-00

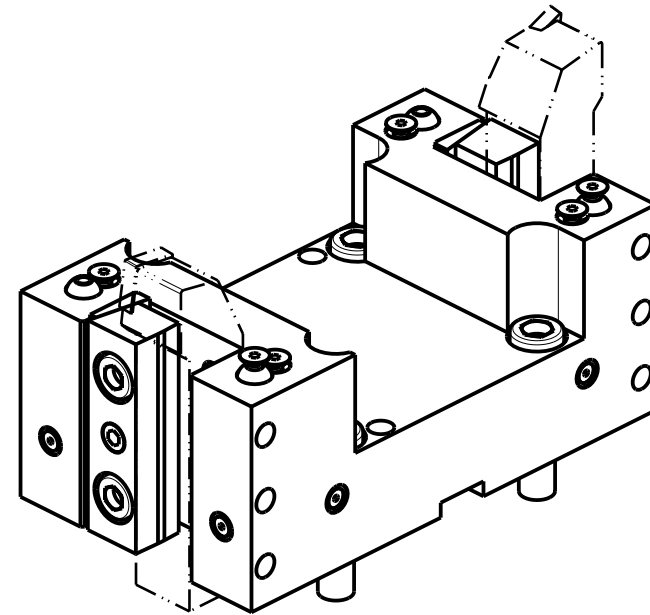
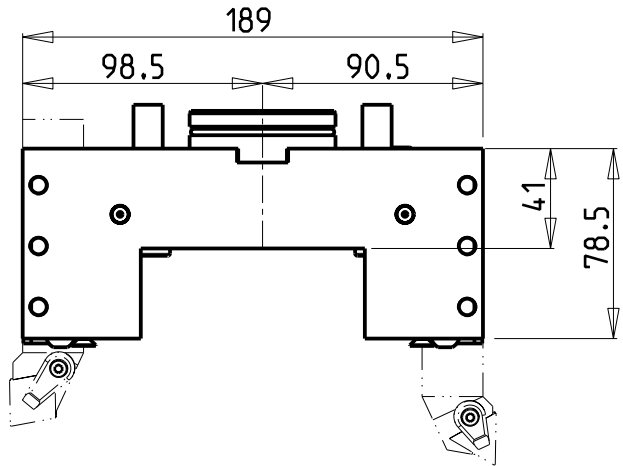
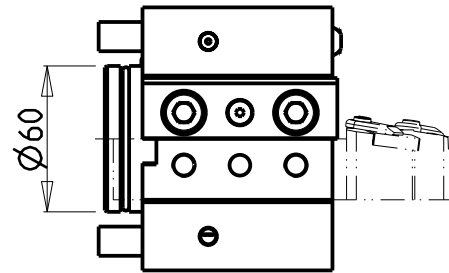
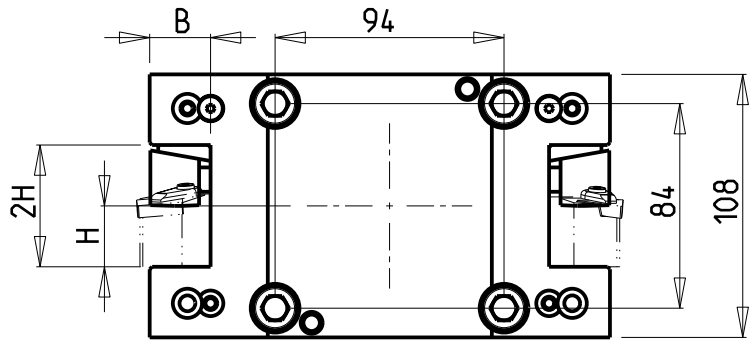

Cod. MT	N°Utensili N°Tools N°Werkzeuge	Reversibile lato mandrino/contromandrino Reversible sub/main spindle side Umkehrbare Spindel-seite/ Gegenspindel-seite	Misure Dimensions Masse	B	H
MNL0052500	2/4	X	mm	25	25
MNL0052540	2/4	X	Inch	1"	1"
MNL0052000	2/4	X	mm	20	20
MNL0051905	2/4	X	Inch	3/4"	3/4"

MT RENT

MT CUT T25Y/SY - MT CUT T32Y/SY

PORTAUTENSILE RADIALE DOPPIO QD=25mm / QD=1" / QD=20mm / QD=3/4"

Radial double static tool QD=25mm / QD=1" / QD=20mm / QD=3/4"

Radial Doppel-Werkzeughalter QD=25mm / QD=1" / QD=20mm / QD=3/4"

Subject to change without notice.

**M.T. srl**

Via Casino Albini 480  
Tel. 0541/956034-957884  
Fax 0541/956341  
47842 S. GIOVANNI IN M. (RN)  
e-mail: mtma@mtmarchetti.com  
http://www.mtmarchetti.com

PRODUZIONE MODULI ROTANTI



PAGINA MTR453-1-00

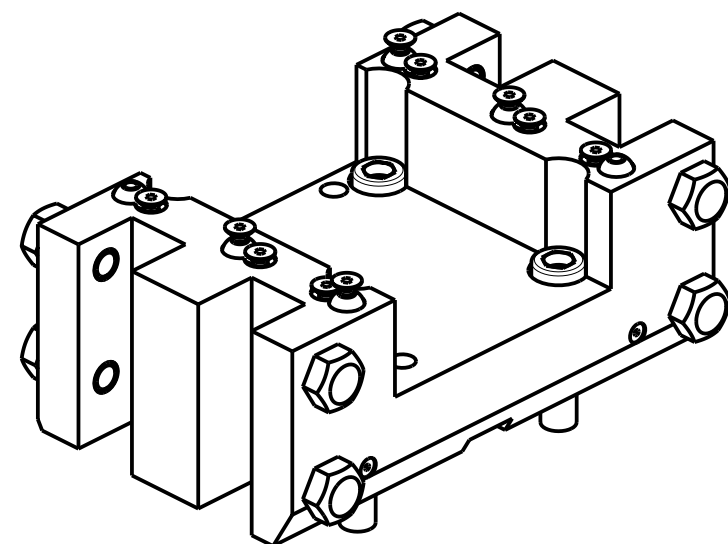
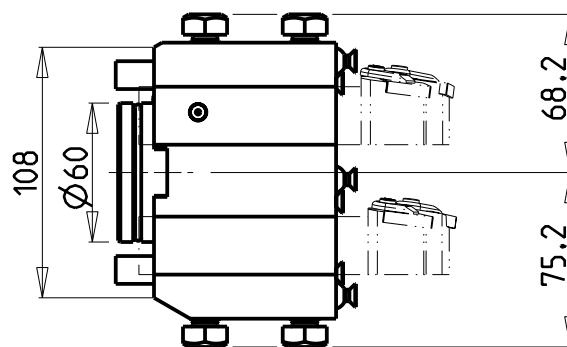
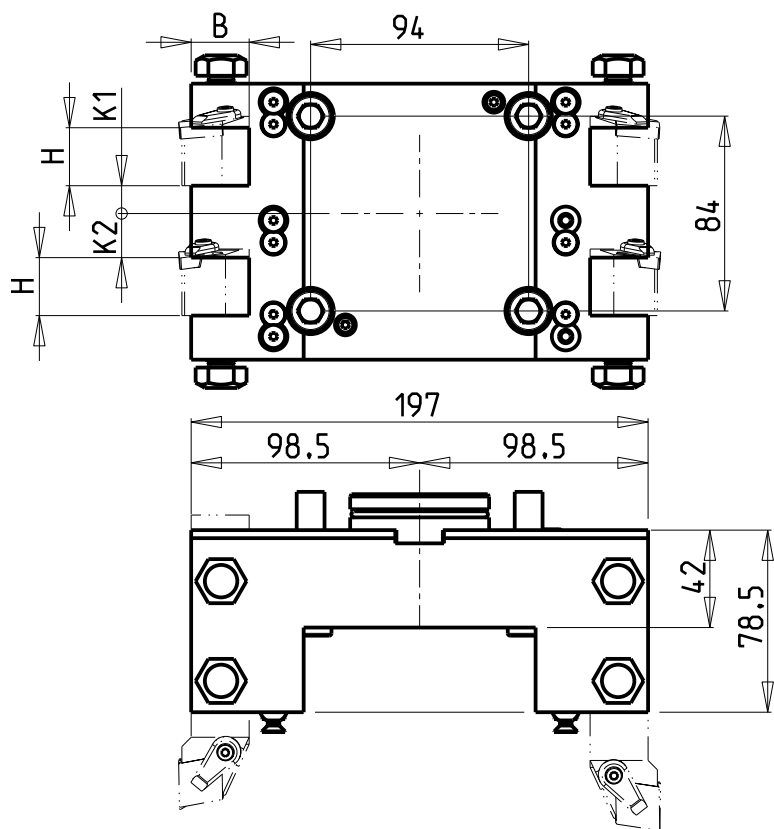

Cod. MT	N°Utensili N°Tools N°Werkzeuge	Reversibile lato mandrino/contromandrino Reversible sub/main spindle side Umkehrbare Spindelseite/ Gegenspindelseite	Misure Dimensions Masse	H	B	K1	K2
MNL0072500	4	X	mm	25	25	12	19
MNL0072540	4	X	Inch	1"	1"	1/2"	3/4"
MNL0072000	4	X	mm	20	20	12	19
MNL0071905	4	X	Inch	3/4"	3/4"	1/2"	3/4"

MT RENT

MT CUT T25Y/SY - MT CUT T32Y/SY

PORTAUTENSILE RADIALE DOPPIO SOVRAPPOSTO QD=25mm / QD=1" / QD=20mm / QD=3/4"

Radial double side twin static tool QD=25mm / QD=1" / QD=20mm / QD=3/4"

Radial Doppel-Werkzeughalter ueberlagert QD=25mm / QD=1" / QD=20mm / QD=3/4"

Subject to change without notice.

**M.T. srl**

Via Casino Albini 480  
Tel. 0541/956034-957884

Fax 0541/956341

47842 S. GIOVANNI IN M. (RN)

e-mail: mtma@tmarchetti.com

http://www.tmmarchetti.com

PRODUZIONE MODULI ROTANTI



PAGINA MTR463-1-00

10/2018



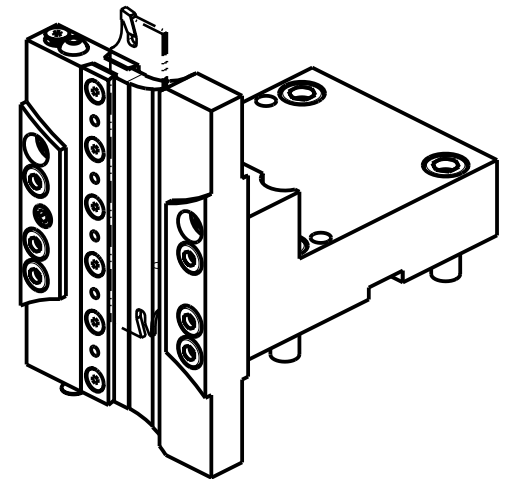
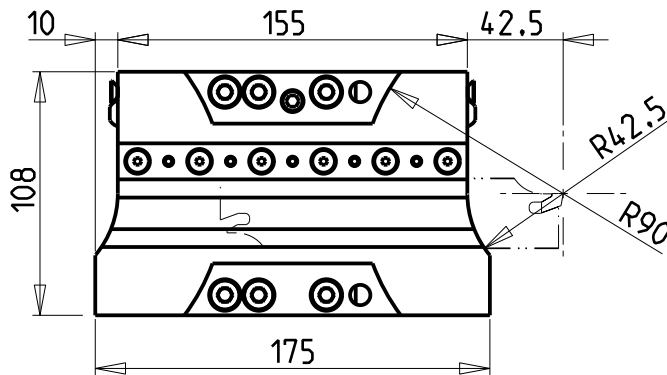
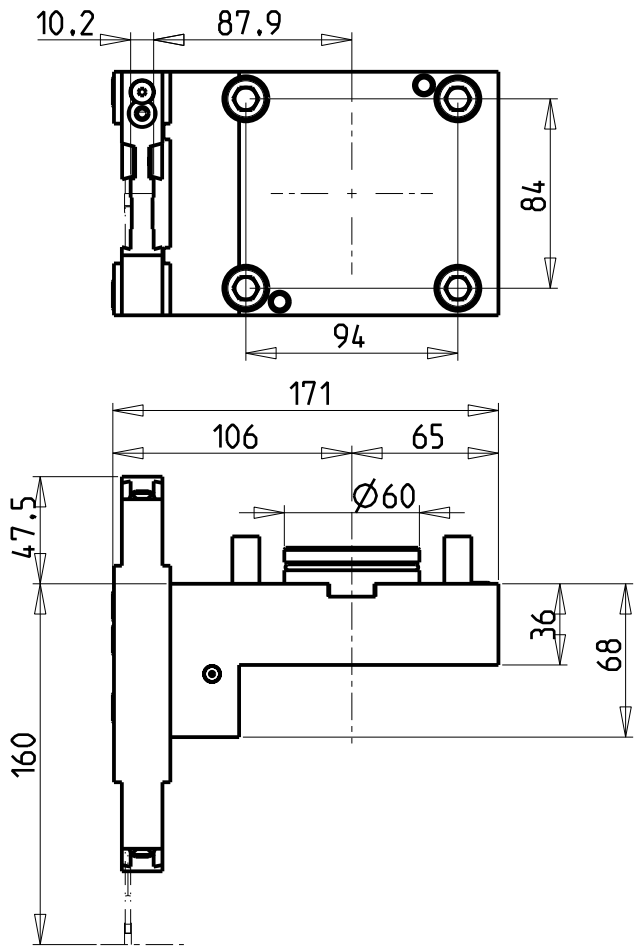

POSSIBILITA' DI LAVORO M3/M4  
 OPTION OF M3/M4 WORKING  
 ARBEITSMÖGLICHKEIT M3/M4

**DOTAZIONI - SUPPLIED WITH - AUSSTATTUNG**

- N°1 - LAMA - BLADE - KLINGE ISCAR H=32 Sp. 3/4mm  
(KENNAMETAL OPTIONAL)
- N°10 - INSERTI - INSERTS - EINLAGEN
- N°1 - CHIAVE A T PER MONTAGGIO INSERTI  
 - T-WRENCH FOR INSERT SET UP  
 - T-SCHLUESSEL FUER EINSATZSTUECK-MONTAGE

Cod. MT

N°Utensili  
 N°Tools  
 N°Werkzeuge

MNL0140132

1

MT RENT  
 MT CUT T25Y/SY - MT CUT T32Y/SY

PORTAUTENSILE PER LAMA DOPPIO  
 Radial double blade holder  
 Radial Doppel-Abstechhalter

Subject to change without notice.

**M.T. srl**

Via Casino Albini 480  
 Tel. 0541/956034-957884  
 Fax 0541/956341  
 47842 S. GIOVANNI IN M. (RN)  
 e-mail: mtma@mtmarchetti.com  
 http://www.mtmarchetti.com

PRODUZIONE MODULI ROTANTI



PAGINA MTR520-1-00

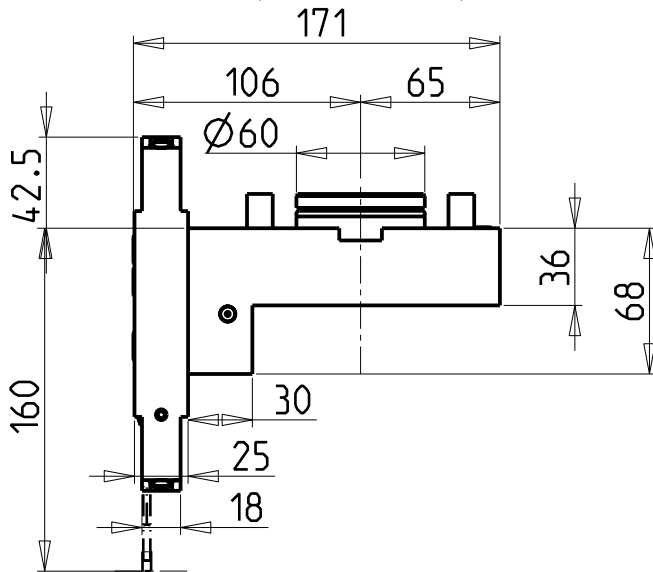
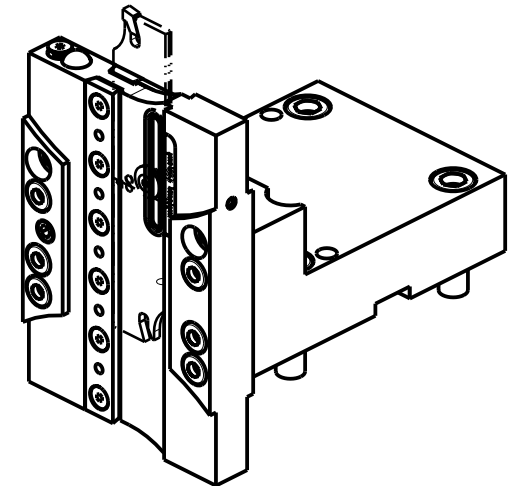
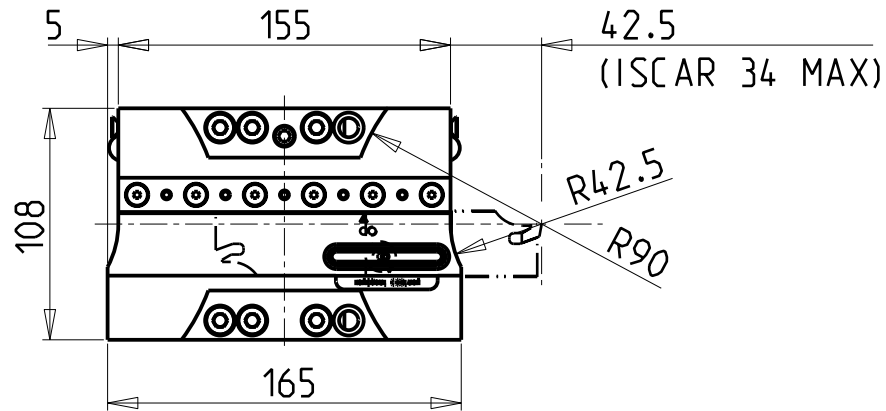
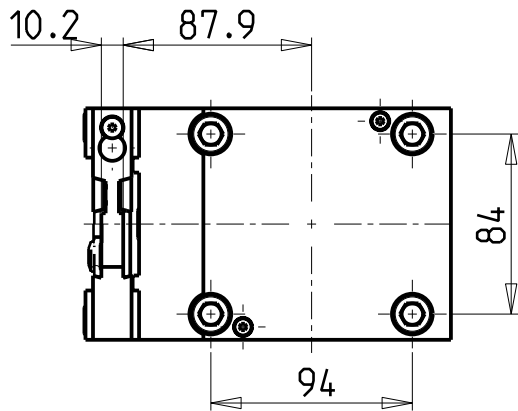

POSSIBILITA' DI LAVORO M3/M4  
 OPTION OF M3/M4 WORKING  
 ARBEITSMÖGLICHKEIT M3/M4

**KIT LAME NON INCLUSI (OPZIONALI)**  
**BLADES NOT SUPPLIED WITH (OPTIONAL)**  
**KLINGEN NICHT INBEGRIFFEN (OPTIONAL)**

- LAMA-BLADE-KLINGE SANDVIK H=32 sp.3 cod. QD\_NN2G60C 25A  
 +INSERTI-INSERTS-EINLAGEN cod. QD\_NG\_0300\_0002\_CM\_1145 (10 pz.)
- LAMA-BLADE-KLINGE SANDVIK H=32 sp.4 cod. QD\_NN2H60C 25A  
 +INSERTI-INSERTS-EINLAGEN cod. QD\_NH\_0400\_0002\_CM\_1145 (10 pz.)
- LAMA-BLADE-KLINGE ISCAR H=32 sp.3 cod. SGFH\_32K\_3  
 +INSERTI-INSERTS-EINLAGEN cod. 6011365 (10pz.)
- LAMA-BLADE-KLINGE ISCAR H=32 sp.4 cod. SGFH\_32K\_4  
 +INSERTI-INSERTS-EINLAGEN cod. 6011366 (10pz.)
- LAMA-BLADE-KLINGE WALTER H=32 sp.3 cod. G2042.32N-3T45SX-P  
 +INSERTI-INSERTS-EINLAGEN cod. SX-3E300N02-CE4 WSM33S (10pz.) + CHIAVE-KEY cod. FS1494
- LAMA-BLADE-KLINGE WALTER H=32 sp.4 cod. G2042.32N-4T50SX-P  
 +INSERTI-INSERTS-EINLAGEN cod. SX-4E400N02-CE4 WSM33S (10pz.) + CHIAVE-KEY cod. FS1494

Cod. MT	N°Utensili N°Tools N°Werkzeuge	Lubr.esterna Ext. coolant Aussenkuehlung	Lubr.interna Coolant through Innenkuehlung
MNL0860132	1	X	P=70bar

MT RENT  
 MT CUT T25Y/SY - MT CUT T32Y/SY

PORTAUTENSILE PER LAMA DOPPIO CON LUBRIFICAZIONE INTERNA  
 Radial double blade holder with internal coolant  
 Radial Doppel-Abstechhalter mit Innenkuehlung

Subject to change without notice.

**M.T. srl**  
 Via Casino Albini 480  
 Tel. 0541/956034-957884  
 Fax 0541/956341  
 47842 S. GIOVANNI IN M. (RN)  
 e-mail: mtma@mtmarchetti.com  
 http://www.mtmarchetti.com

PRODUZIONE MODULI ROTANTI



PAGINA MTR520-1-04

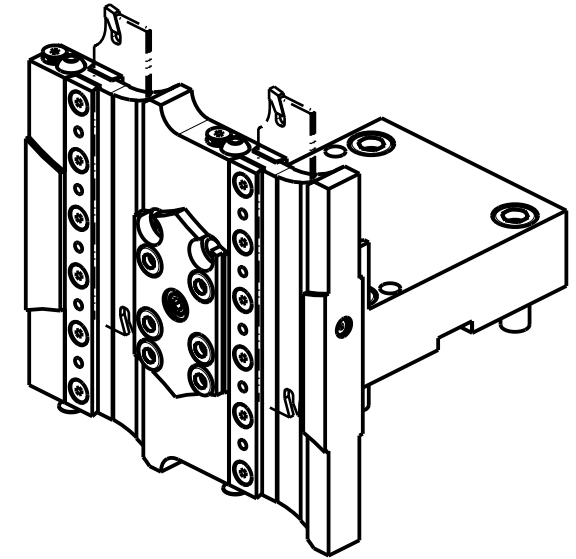
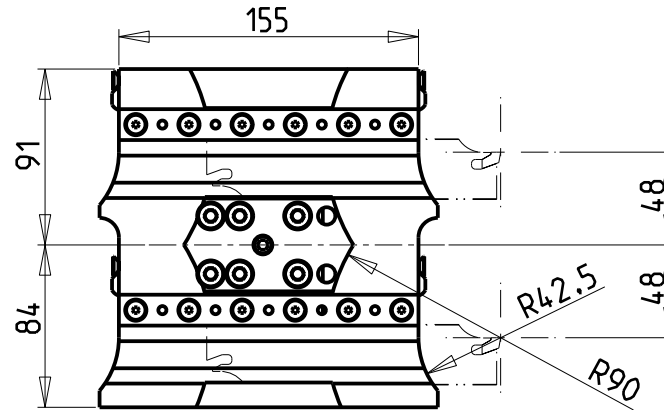
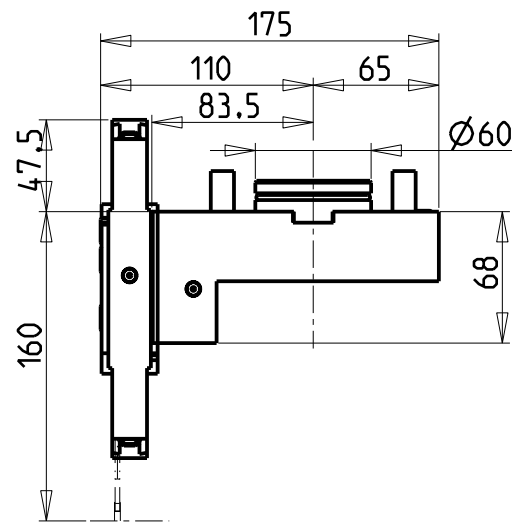
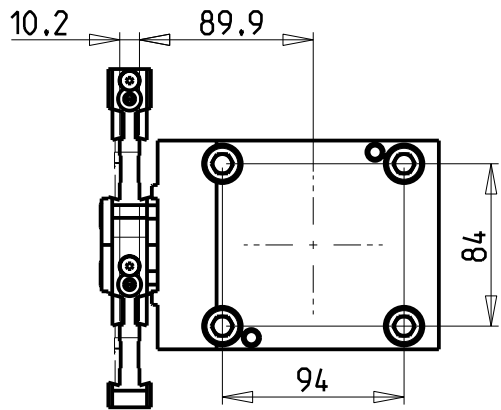

POSSIBILITA' DI LAVORO M3/M4  
 OPTION OF M3/M4 WORKING  
 ARBEITSMOGLICHKEIT M3/M4

SOLO PER MACCHINE CON ASSE Y  
 ONLY FOR Y-AXIS MACHINES  
 NUR FUR MASCHINEN MIT ACHSE Y

**DOTAZIONI - SUPPLIED WITH - AUSSTATTUNG**

- N°1 - LAMA - BLADE - KLINGE ISCAR H=32 Sp. 3/4mm (KENNAMETAL OPTIONAL)
- N°10 - INSERTI - INSERTS - EINLAGEN
- N°1 - CHIAVE A T PER MONTAGGIO INSERTI  
 - T-WRENCH FOR INSERT SET UP  
 - T-SCHLUESSEL FUER EINSATZSTUECK-MONTAGE

Cod. MT

N°Utensili  
 N° Tools  
 N° Werkzeuge

MNL0160232

2

MT RENT  
 MT CUT T25Y/SY - MT CUT T32Y/SY  
 PORTAUTENSILE PER LAMA DOPPIO SOVRAPPOSTO  
 Radial double twin-side blade holder  
 Radial Doppel-Abstechhalter ueberlagert

Subject to change without notice.

**M.T. srl**

Via Casino Albini 480  
 Tel. 0541/956034-957884  
 Fax 0541/956341  
 47842 S. GIOVANNI IN M. (RN)  
 e-mail: mtma@mtmarchetti.com  
 http://www.mtmarchetti.com

PRODUZIONE MODULI ROTANTI



PAGINA MTR525-1-00

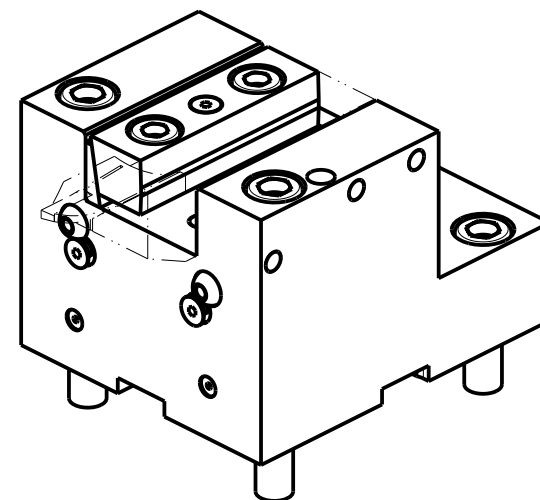
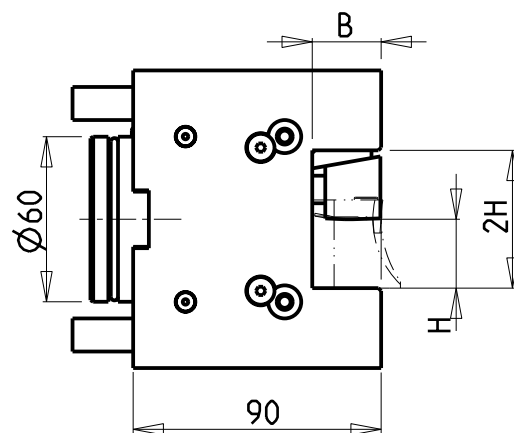
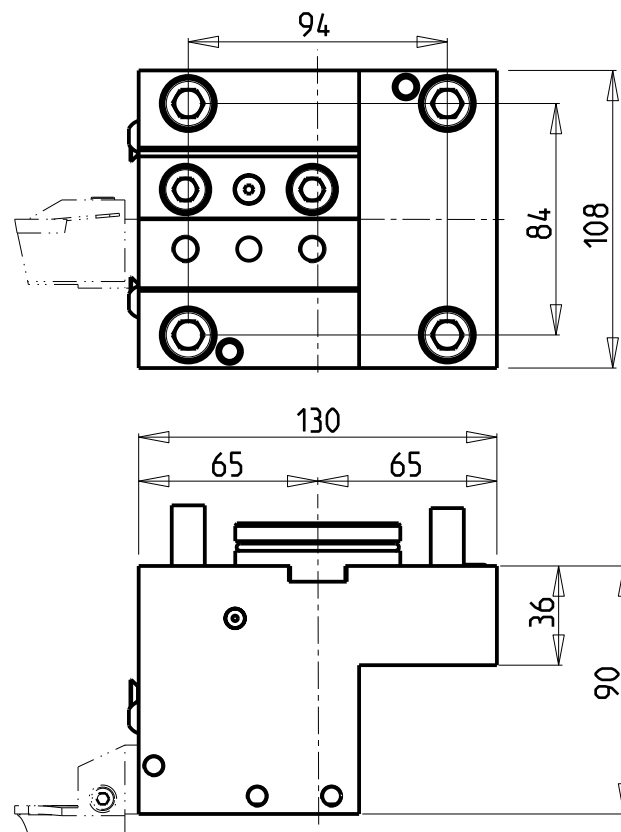

Cod. MT	N°Utensili N°Tools N°Werkzeuge	Reversibile lato mandrino/contromandrino Reversible sub/main spindle side Umkehrbare Spindel-seite/ Gegenspindel-seite	Misure Dimensions Masse	B	H
MNL0132500	1/2	X	mm	25	25
MNL0132540	1/2	X	Inch	1"	1"
MNL0132000	1/2	X	mm	20	20
MNL0131905	1/2	X	Inch	3/4"	3/4"

MT RENT  
MT CUT T25Y/SY - MT CUT T32Y/SY

PORTAUTENSILE ASSIALE SINGOLO QD=25mm / QD=1" / QD=20mm / QD=3/4"  
Single axial static tool QD=25mm / QD=1" / QD=20mm / QD=3/4"  
Axial Single-Werkzeughalter QD=25mm / QD=1" / QD=20mm / QD=3/4"

Subject to change without notice.

**M.T. srl**

Via Casino Albini 480  
Tel. 0541/956034-957884  
Fax 0541/956341  
47842 S. GIOVANNI IN M. (RN)  
e-mail: mtma@mtmarchetti.com  
http://www.mtmarchetti.com

PRODUZIONE MODULI ROTANTI



PAGINA MTR552-1-00

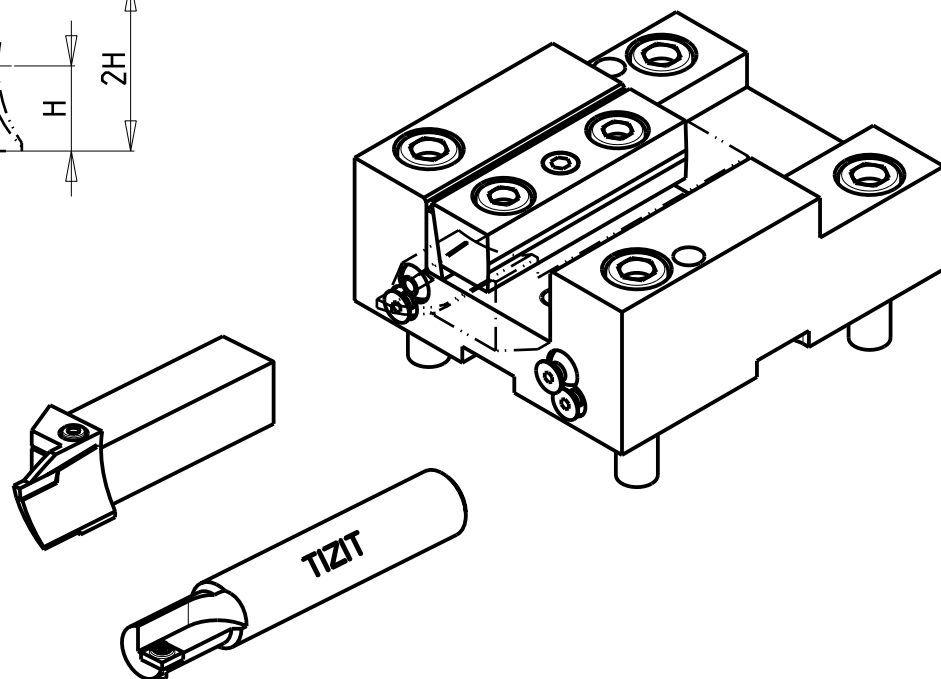
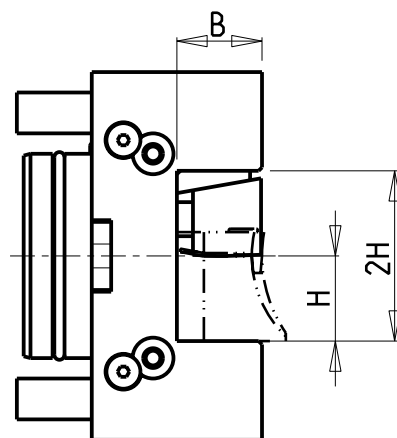
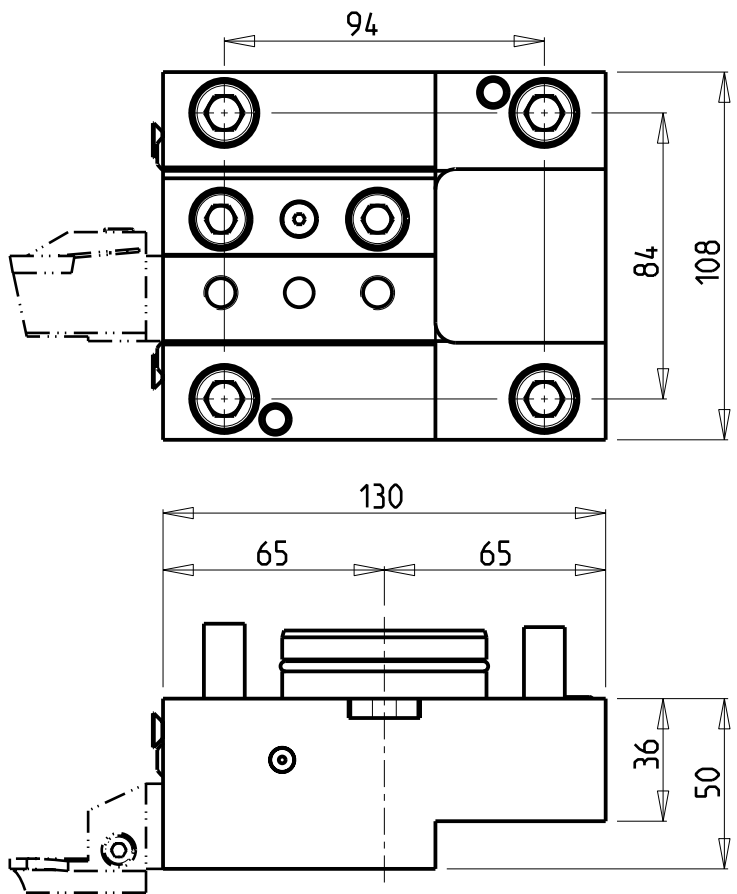

Cod. MT	N°Utensili N° Tools N° Werkzeuge	Reversibile lato mandrino/contromandrino Reversible sub/main spindle side Umkehrbare Spindel-seite/ Gegenspindel-seite	Misure Dimensions Masse	B	H
MNL0302500	1	X	mm	25	25
MNL0302000	1	X	mm	20	20

MT RENT

MT CUT T25Y/SY - MT CUT T32Y/SY

PORTAUTENSILE ASSIALE RIBASSATO SINGOLO QD=25mm / QD=20mm

Axial single lower height static tool QD=25mm / QD=20mm

Axial Single-Werkzeughalter abgeflacht QD=25mm / QD=20mm

Subject to change without notice.

**M.T. srl**

Via Casino Albini 480

Tel. 0541/956034-957884

Fax 0541/956341

47842 S. GIOVANNI IN M. (RN)

e-mail: mtma@mtmarchetti.com

http://www.mtmarchetti.com

PRODUZIONE MODULI ROTANTI



PAGINA MTR562-1-00

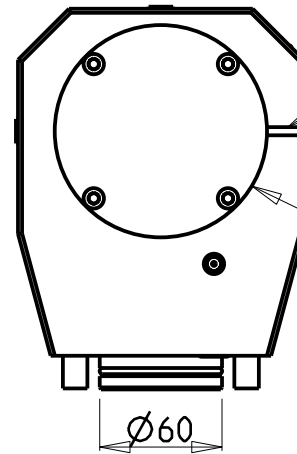
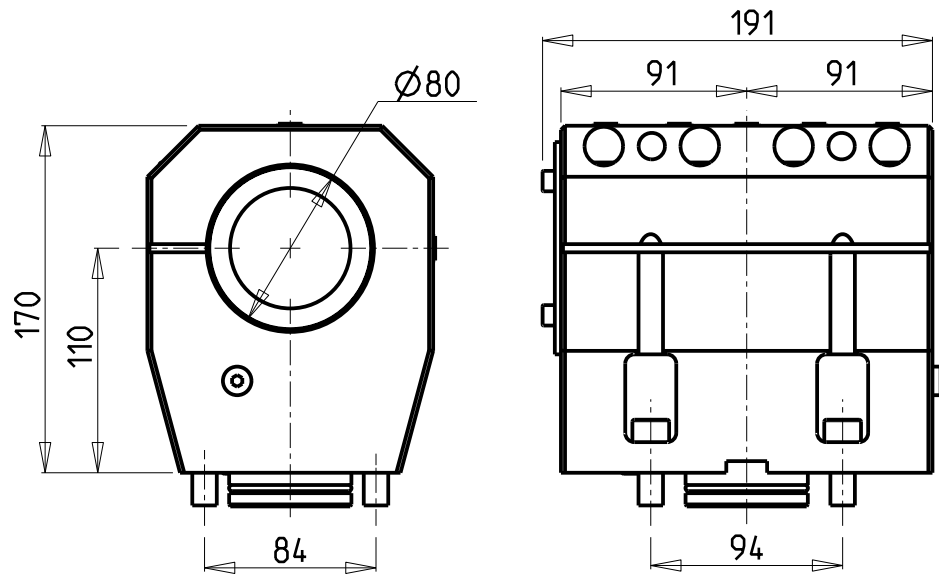

SOLO GUARNIZIONE (OPZIONALE)  
 ONLY SEAL (OPTIONAL)  
 NUR DICHTUNG (OPTIONAL)  
 cod. MNL0620002

KIT ADDUZIONE INTERNA (OPZIONALE)  
 KIT FOR INTERNAL COOLANT (OPTIONAL)  
 KIT FUER INTERNE KUEHLMITTELZUFUHR (OPTIONAL)  
 Ø80 cod. KIT1005013

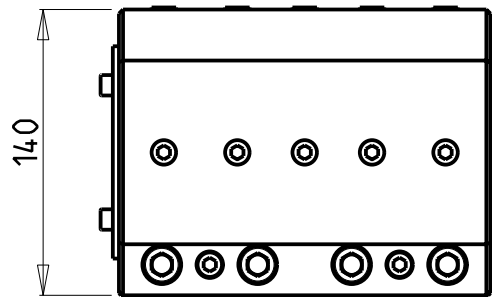

**ATTENZIONE - ATTENTION - ACHTUNG**

- VERIFICARE LE MISURE DI INGOMBRO PER POSSIBILE INTERFERENZA SU ALCUNI MODELLI DI MACCHINE
- Please check the overall sizes for possible interferences on some machine models
- Bitte überprüfen sie das ausmass um mögliche interferenzen auf einigen maschinen modellen zu vermeiden

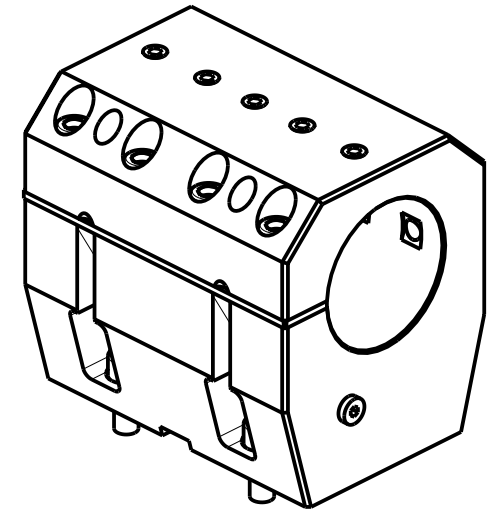

PER BOCCOLE DI RIDUZIONE VEDI PAG. TBL150-1-00  
 FOR REDUCING BUSHINGS SEE PAGE TBL150-1-00  
 FÜR REDUZIERBUCHSE SIEHE SEITE TBL150-1-00

Cod. MT	N°Utensili N°Tools N°Werkzeuge	Lubrificazione int. opzionale Coolant through optional Innenkühlung Optional	Lubrificazione est. Ext. coolant Aussenkühlung
MNL0628000	1	X	X

MT RENT  
 MT CUT T25Y/SY - MT CUT T32Y/SY  
 PORTAUTENSILE ASSIALE PER BARENO Ø80mm H=110mm  
 Axial single boring bar holder Ø80mm H=110mm  
 Axial Bohrhälter Ø80mm H=110mm

**M.T. srl**  
 Via Casino Albini 480  
 Tel. 0541/956034-957884  
 Fax 0541/956341  
 47842 S. GIOVANNI IN M. (RN)  
 e-mail: mtma@mtmarchetti.com  
 http://www.mtmarchetti.com

PRODUZIONE MODULI ROTANTI



PAGINA MTR580-1-20

Subject to change without notice.

10/2018

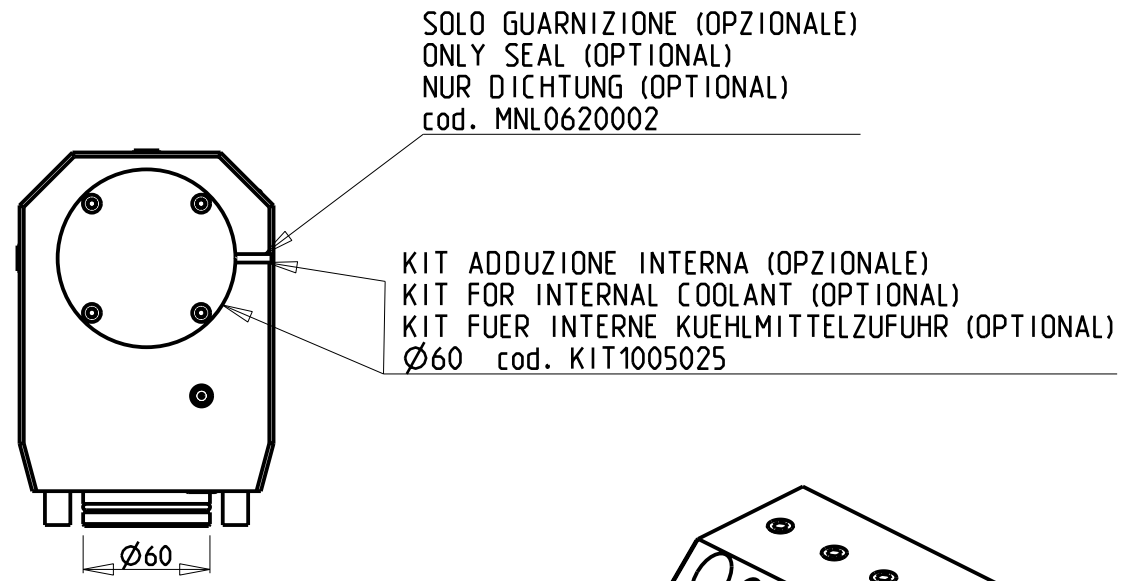
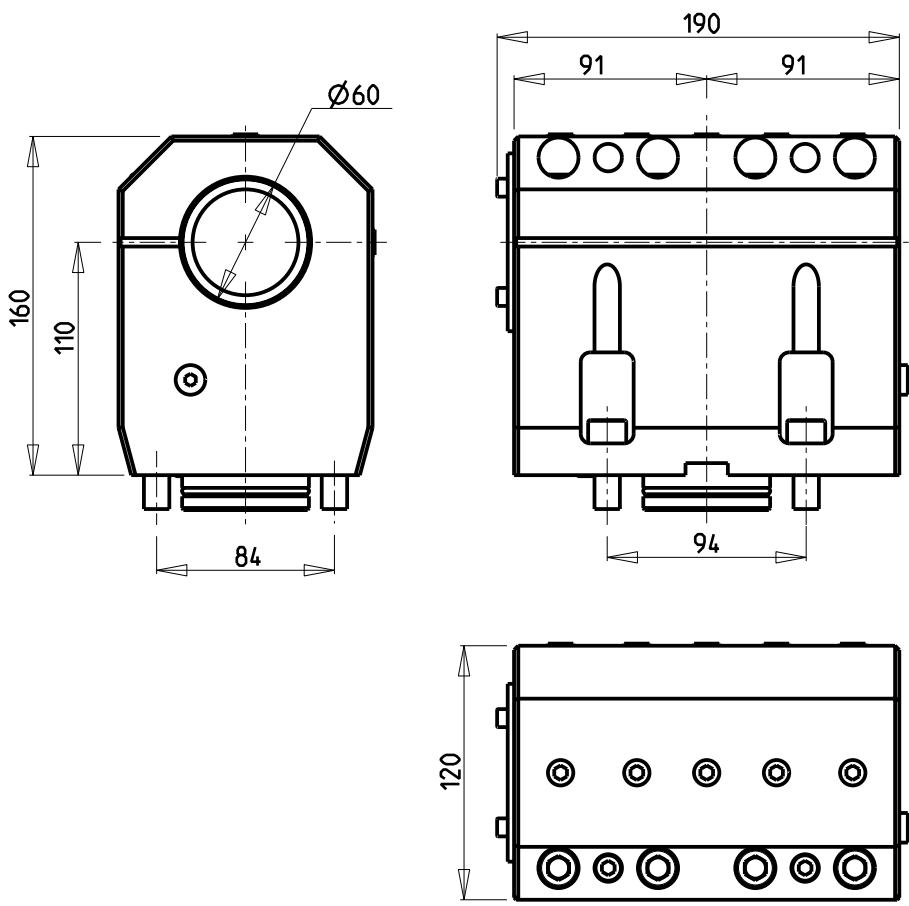

SOLO GUARNIZIONE (OPZIONALE)  
 ONLY SEAL (OPTIONAL)  
 NUR DICHTUNG (OPTIONAL)  
 cod. MNL0620002

KIT ADDUZIONE INTERNA (OPZIONALE)  
 KIT FOR INTERNAL COOLANT (OPTIONAL)  
 KIT FUER INTERNE KUEHLMITTELZUFUHR (OPTIONAL)  
 Ø60 cod. KIT1005025

ATTENZIONE - ATTENTION - ACHTUNG

- VERIFICARE LE MISURE DI INGOMBRO PER POSSIBILE INTERFERENZA SU ALCUNI MODELLI DI MACCHINE
- Please check the overall sizes for possible interferences on some machine models
- Bitte überprüfen sie das ausmass um mögliche interferenzen auf einigen maschinen modellen zu vermeiden

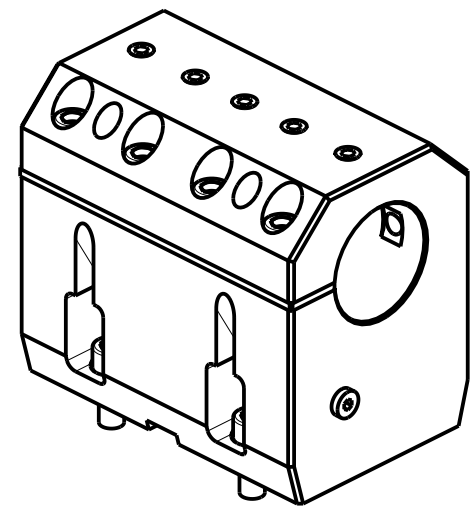

Cod. MT	N°Utensili N°Tools N°Werkzeuge	Lubrificazione int. opzionale Coolant through optional Innenkühlung Optional	Lubrificazione est. Ext. coolant Aussenkühlung
MNL0616000	1	X	X

PER BOCCOLE DI RIDUZIONE VEDI PAG. TBL150-1-00  
 FOR REDUCING BUSHINGS SEE PAGE TBL150-1-00  
 FÜR REDUZIERBUCHSE SIEHE SEITE TBL150-1-00

MT RENT  
 MT CUT T25Y/SY - MT CUT T32Y/SY  
 PORTAUTENSILE ASSIALE PER BARENO Ø60mm H=110mm  
 Axial single boring bar holder Ø60mm H=110mm  
 Axial Bohrhälter Ø60mm H=110mm

**M.T. srl**  
 Via Casino Albini 480  
 Tel. 0541/956034-957884  
 Fax 0541/956341  
 47842 S. GIOVANNI IN M. (RN)  
 e-mail: mtma@mtmarchetti.com  
 http://www.mtmarchetti.com

PRODUZIONE MODULI ROTANTI



PAGINA MTR590-1-20

Subject to change without notice.

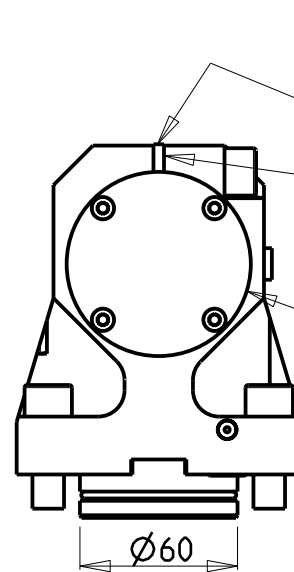
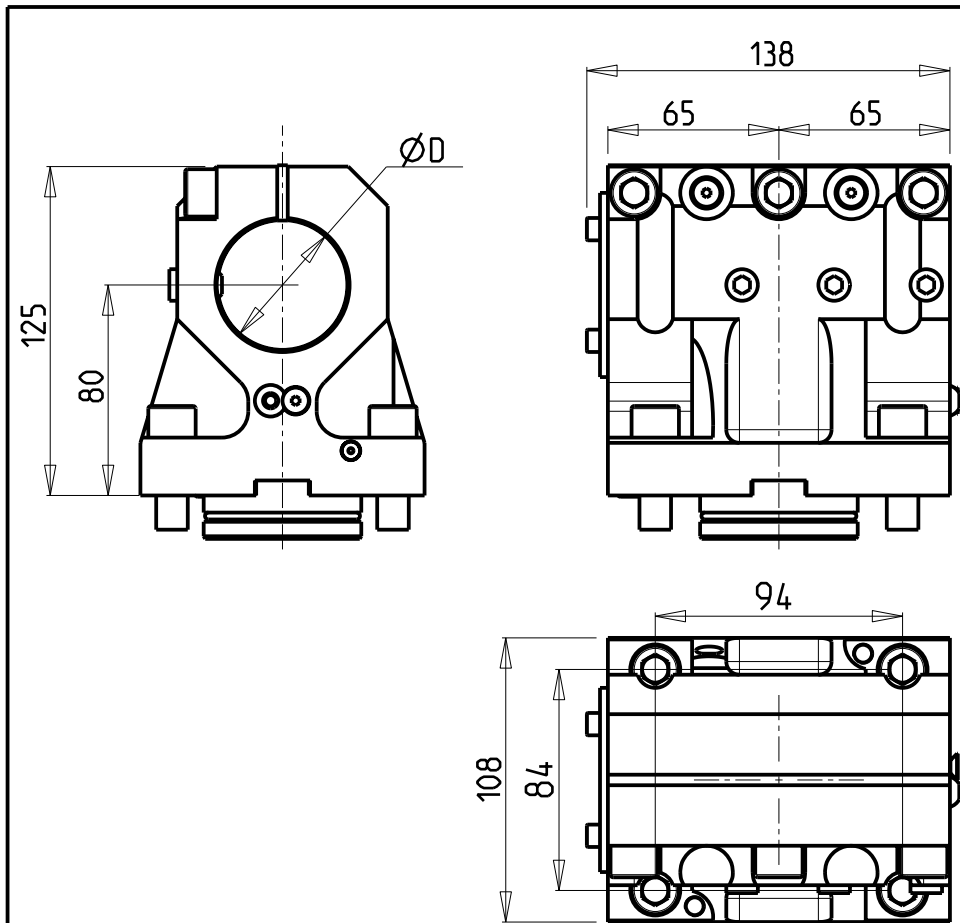

SOLO GUARNIZIONE (OPZIONALE)  
 ONLY SEAL (OPTIONAL)  
 NUR DICHTUNG (OPTIONAL)  
 cod. MNL0110008

KIT ADDUZIONE INTERNA (OPZIONALE)  
 KIT FOR INTERNAL COOLANT (OPTIONAL)  
 KIT FUER INTERNE KUEHLMITTELZUFUHR (OPTIONAL)  
 Ø50-Ø2" cod. KIT1001002

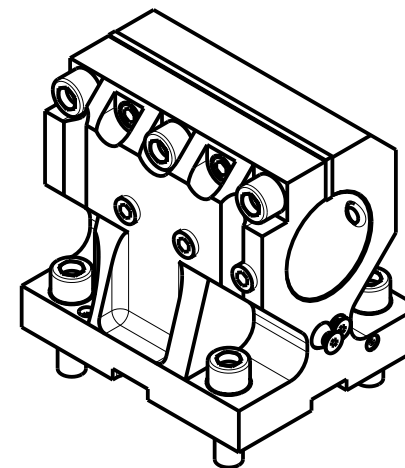

PER BOCCOLE DI RIDUZIONE VEDI PAG. TBL150-1-00  
 FOR REDUCING BUSHINGS SEE PAGE TBL150-1-00  
 FUR REDUZIERBUCHSE SIEHE SEITE TBL150-1-00

Cod. MT	N°Utensili N°Tools N°Werkzeuge	Reversibile lato mandrino/contromandrino Reversible sub/main spindle side Umkehrbare Spindel-seite/ Gegenspindel-seite	Lubrificazione int. opzionale Coolant through optional Innenkuehlung Optional	Lubrificazione est. Ext. coolant Aussenkuehlung	Misure Dimensions Masse	D
MNL0115000	1	X	X	X	mm	50
MNL0115080	1	X	X	X	Inch	2"

MT RENT

MT CUT T25Y/SY - MT CUT T32Y/SY

PORTAUTENSILE ASSIALE PER BARENO Ø50mm / Ø2" H=80mm

Axial single boring bar holder Ø50mm / Ø2" H=80mm

Axial Bohrhälter Ø50mm / Ø2" H=80mm

Subject to change without notice.

**M.T. srl**

Via Casino Albini 480

Tel. 0541/956034-957884

Fax 0541/956341

47842 S. GIOVANNI IN M. (RN)

e-mail: mtma@mtmarchetti.com

http://www.mtmarchetti.com

PRODUZIONE MODULI ROTANTI



PAGINA MTR610-1-20



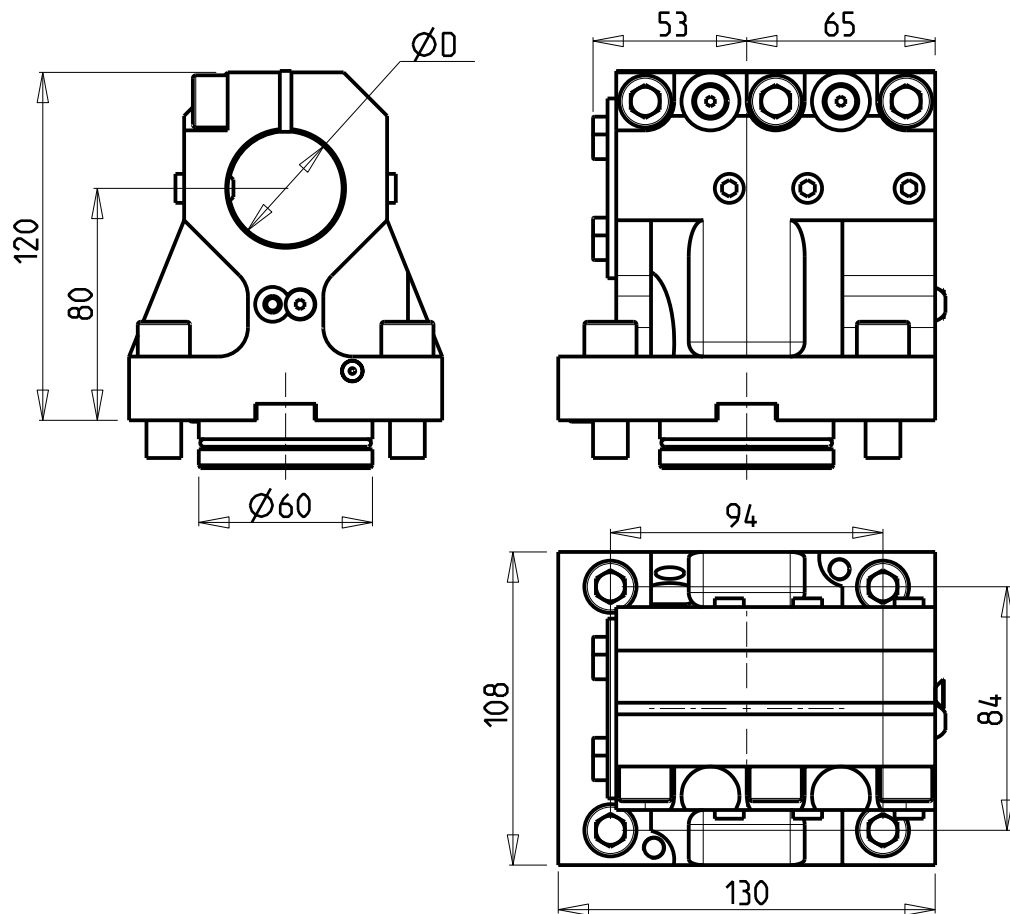

SOLO GUARNIZIONE (OPZIONALE)  
 ONLY SEAL (OPTIONAL)  
 NUR DICHTUNG (OPTIONAL)  
 cod. 0520013

KIT ADDUZIONE INTERNA (OPZIONALE)  
 KIT FOR INTERNAL COOLANT (OPTIONAL)  
 KIT FUER INTERNE KUEHLMITTELZUFUHR (OPTIONAL)  
 Ø40 cod. KIT1003003  
 Ø1 1/2" cod. KIT1003004

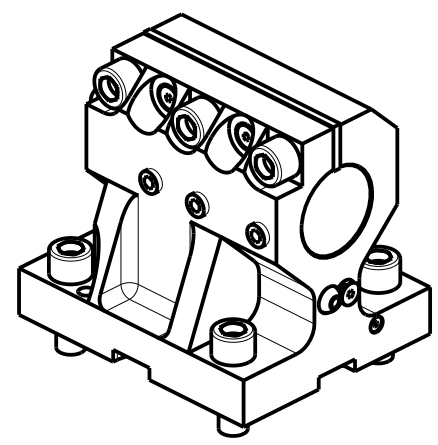

PER BOCCOLE DI RIDUZIONE VEDI PAG. TBL150-1-00  
 FOR REDUCING BUSHINGS SEE PAGE TBL150-1-00  
 FUR REDUZIERBUCHSE SIEHE SEITE TBL150-1-00

Cod. MT	N°Utensili N° Tools N° Werkzeuge	Reversibile lato mandrino/contromandrino Reversible sub/main spindle side Umkehrbare Spindel-seite/ Gegenspindel-seite	Lubrificazione int. opzionale Coolant through optional Innenkuhlung Optional	Lubrificazione est. Ext. coolant Aussenkuhlung	Misure Dimensions Masse	Ø.
MNL0114000	1	X	X	X	mm	40
MNL0113810	1	X	X	X	Inch	1 1/2"

MT RENT  
 MT CUT T25Y/SY - MT CUT T32Y/SY

PORTAUTENSILE ASSIALE PER BARENO Ø40mm / Ø1 1/2" H=80mm  
 Axial single boring bar holder Ø40mm / Ø1 1/2" H=80mm  
 Axial Bohrhälter Ø40mm / Ø1 1/2" H=80mm

Subject to change without notice.

**M.T. srl**  
 Via Casino Albini 480  
 Tel. 0541/956034-957884  
 Fax 0541/956341  
 47842 S. GIOVANNI IN M. (RN)  
 e-mail: mtma@mtmarchetti.com  
 http://www.mtmarchetti.com

PRODUZIONE MODULI ROTANTI



PAGINA MTR630-1-20

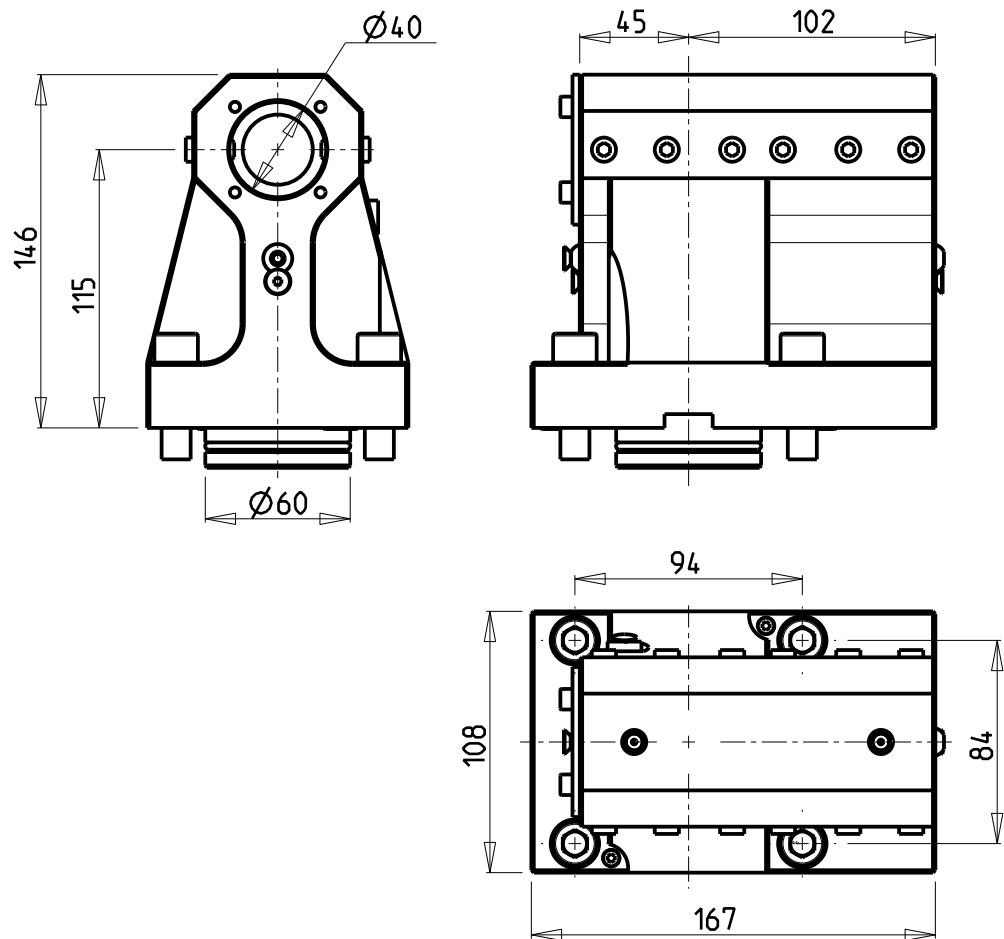

KIT ADDUZIONE INTERNA (OPZIONALE)  
 KIT FOR INTERNAL COOLANT (OPTIONAL)  
 KIT FUER INTERNE KUEHLMITTELZUFUHR (OPTIONAL)  
 Ø40 cod. KIT1000003

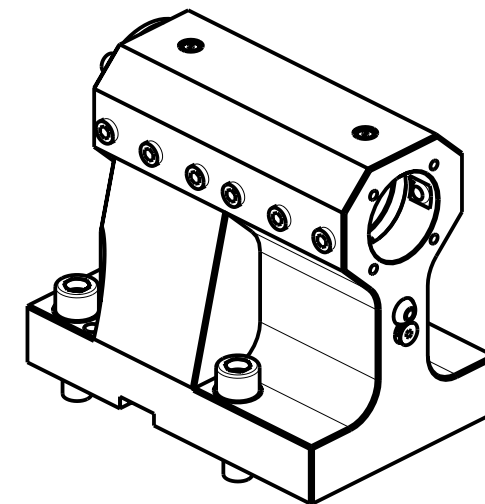

PER BOCCOLE DI RIDUZIONE VEDI PAG. TBL150-1-00  
 FOR REDUCING BUSHINGS SEE PAGE TBL150-1-00  
 FÜR REDUZIERBUCHSE SIEHE SEITE TBL150-1-00

Cod. MT	N°Utensili N°Tools N°Werkzeuge	Reversibile lato mandrino/contromandrino Reversible sub/main spindle side Umkehrbare Spindel-seite/ Gegenspindel-seite	Lubrificazione int. opzionale Coolant through optional Innenkühlung Optional	Lubrificazione est. Ext. coolant Aussenkühlung
MNL0604000	1	X	X	X

MT RENT  
 MT CUT T25Y/SY - MT CUT T32Y/SY

PORTAUTENSILE ASSIALE PROLUNGATO PER BARENO Ø40mm H=115mm  
 Axial single extended boring bar holder Ø40mm H=115mm  
 Axial Bohrhälter verlaengerf Ø40mm H=115mm

Subject to change without notice.

**M.T. srl**

Via Casino Albini 480  
 Tel. 0541/956034-957884  
 Fax 0541/956341  
 47842 S. GIOVANNI IN M. (RN)  
 e-mail: mtma@mtmarchetti.com  
 http://www.mtmarchetti.com

PRODUZIONE MODULI ROTANTI



PAGINA MTR760-1-10

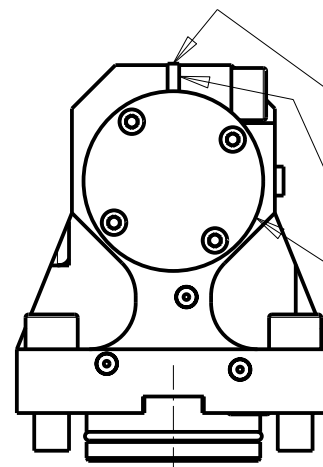
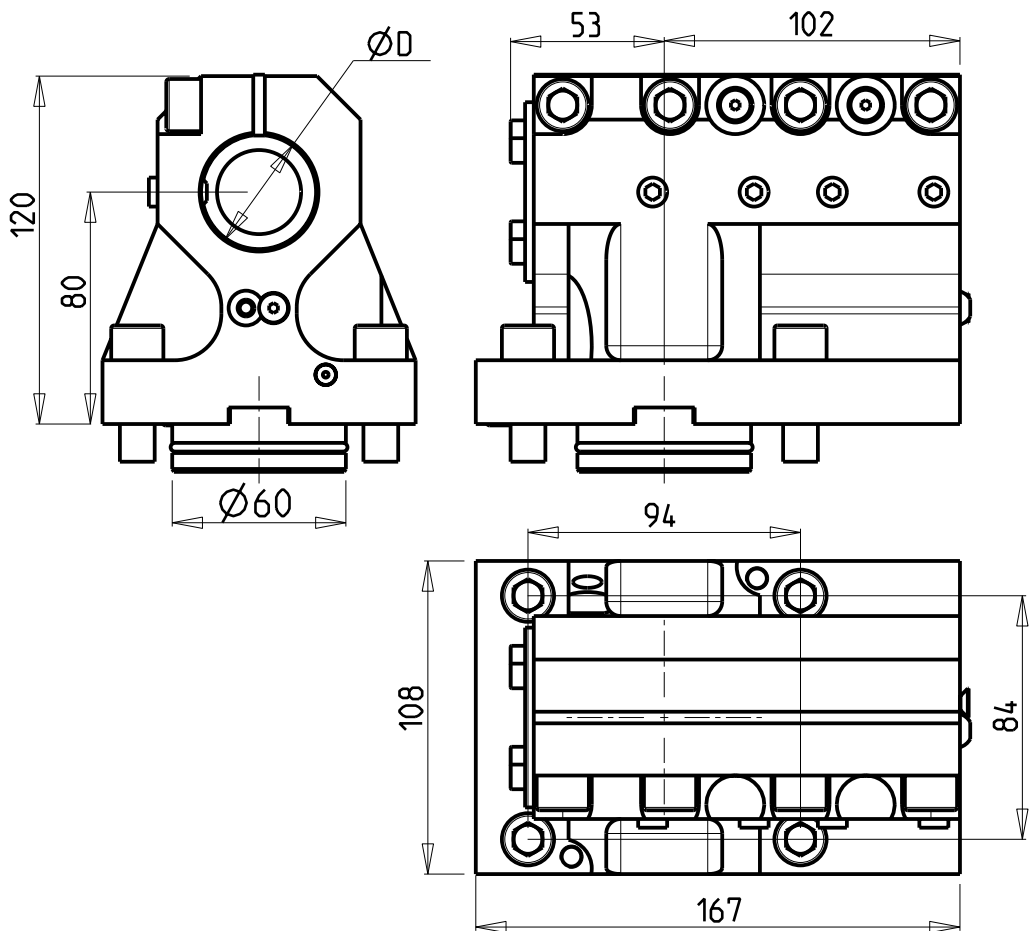

SOLO GUARNIZIONE (OPZIONALE)  
 ONLY SEAL (OPTIONAL)  
 NUR DICHTUNG (OPTIONAL)  
 cod. MNL0310005

KIT ADDUZIONE INTERNA (OPZIONALE)  
 KIT FOR INTERNAL COOLANT (OPTIONAL)  
 KIT FUER INTERNE KUEHLMITTELZUFUHR (OPTIONAL)  
 Ø40 cod. KIT1002003  
 Ø1 1/2" cod. KIT1002004

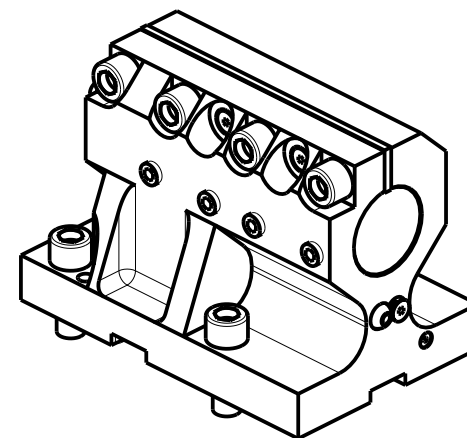

PER BOCCOLE DI RIDUZIONE VEDI PAG. TBL150-1-00  
 FOR REDUCING BUSHINGS SEE PAGE TBL150-1-00  
 FÜR REDUZIERBUCHSE SIEHE SEITE TBL150-1-00

Cod. MT	N°Utensili N° Tools N° Werkzeuge	Reversibile lato mandrino/contromandrino Reversible sub/main spindle side Umkehrbare Spindel-seite/ Gegenspindel-seite	Lubrificazione int. opzionale Coolant through optional Innenkuhlung Optional	Lubrificazione est. Ext. coolant Aussenkuhlung ..	Misure Dimensions Masse	D
MNL0314000	1	X	X	X	mm	40
MNL0313810	1	X	X	X	inch	1 1/2"

MT RENT  
 MT CUT T25Y/SY - MT CUT T32Y/SY

PORTAUTENSILE ASSIALE PROLUNGATO PER BARENO Ø40mm / Ø1 1/2" H=80mm  
 Axial single extended boring bar holder Ø40mm / Ø1 1/2" H=80mm  
 Axial Bohrhälter verlaengerf Ø40mm / Ø1 1/2" H=80mm

Subject to change without notice.

**M.T. srl**

Via Casino Albini 480  
 Tel. 0541/956034-957884  
 Fax 0541/956341  
 47842 S. GIOVANNI IN M. (RN)  
 e-mail: mtma@mtmarchetti.com  
 http://www.mtmarchetti.com

PRODUZIONE MODULI ROTANTI



PAGINA MTR760-1-20

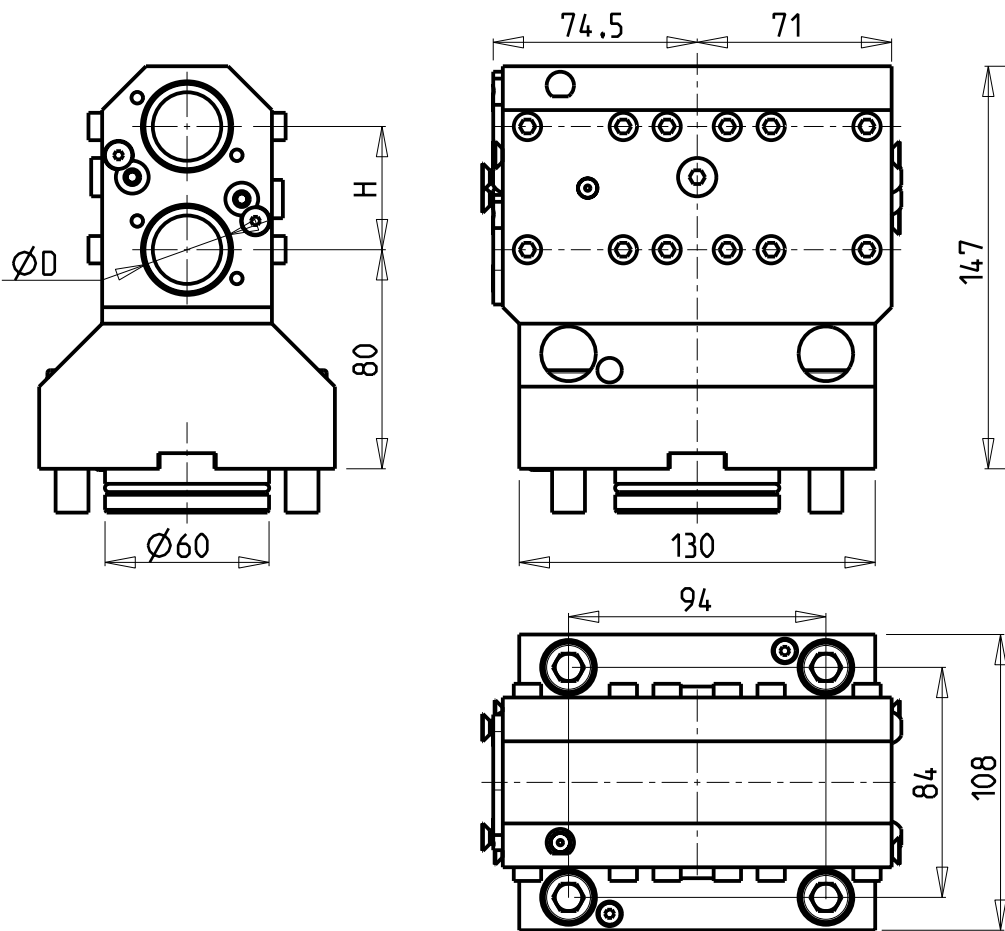

KIT ADDUZIONE INTERNA (OPZIONALE)  
 KIT FOR INTERNAL COOLANT (OPTIONAL)  
 KIT FUER INTERNE KUEHLMITTELZUFUHR (OPTIONAL)  
 cod. KIT1000001

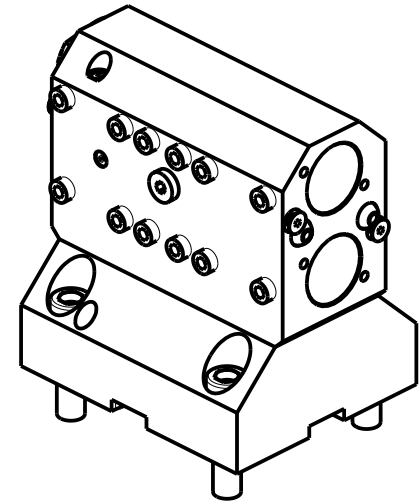

PER BOCCOLE DI RIDUZIONE VEDI PAG. TBL150-1-00  
 FOR REDUCING BUSHINGS SEE PAGE TBL150-1-00  
 FÜR REDUZIERBUCHSE SIEHE SEITE TBL150-1-00

Cod. MT	N°Utensili N°Tools N°Werkzeuge	Lubrificazione int. opzionale Coolant through optional Innenkuehlung Optional	Lubrificazione est. Ext. coolant Aussenkuehlung	Misure Dimensions Masse	D	H
MNL0103200	2+2	X	X	mm	32	45
MNL0103175	2+2	X	X	Inch	1 1/4"	1 3/4"

MT RENT  
 MT CUT T25Y/SY - MT CUT T32Y/SY

PORTAUTENSILE ASSIALE PER BARENO 2+2 POSIZIONI Ø32mm / Ø1 1/4"  
 Axial 2+2 position boring bar holder Ø32mm / Ø1 1/4"  
 Axial Bohrhalter 2+2 Positionen Ø32mm / Ø1 1/4"

Subject to change without notice.

**M.T. srl**

Via Casino Albini 480  
 Tel. 0541/956034-957884  
 Fax 0541/956341  
 47842 S. GIOVANNI IN M. (RN)  
 e-mail: mtma@mtmarchetti.com  
 http://www.mtmarchetti.com

PRODUZIONE MODULI ROTANTI



PAGINA MTR872-1-00

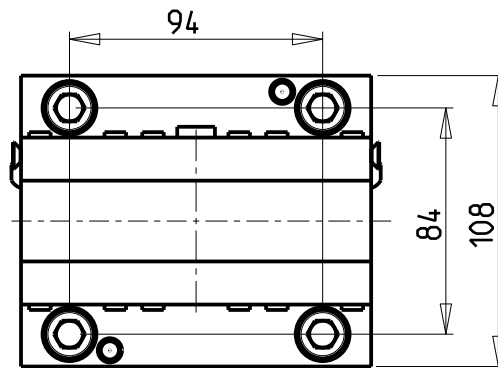
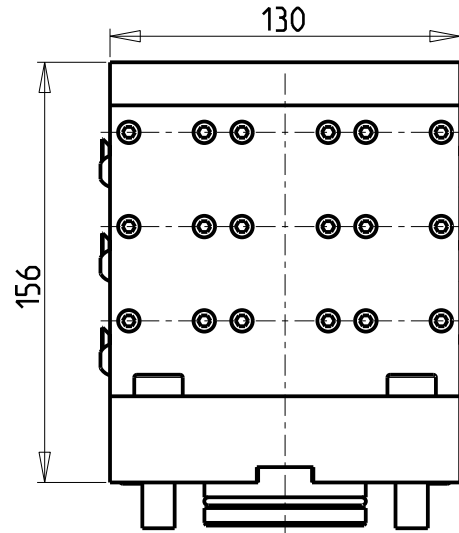
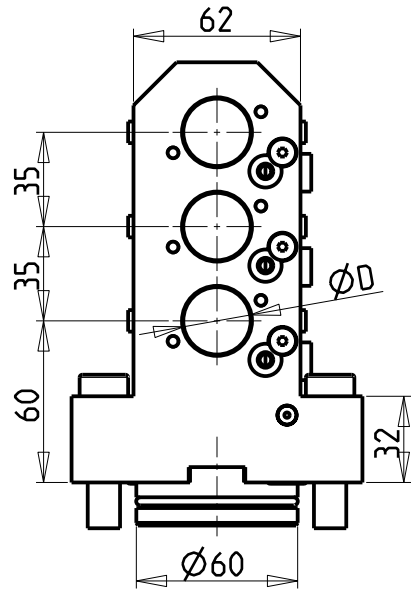

KIT ADDUZIONE INTERNA (OPZIONALE)  
 KIT FOR INTERNAL COOLANT (OPTIONAL)  
 KIT FUER INTERNE KUEHLMITTELZUFUHR (OPTIONAL)  
 cod. KIT1000006

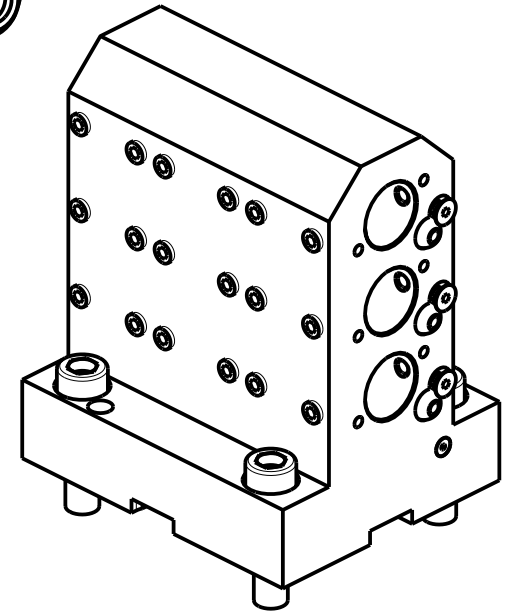

PER BOCCOLE DI RIDUZIONE VEDI PAG. TBL150-1-00  
 FOR REDUCING BUSHINGS SEE PAGE TBL150-1-00  
 FÜR REDUZIERBUCHSE SIEHE SEITE TBL150-1-00

Cod. MT	N°Utensili N°Tools N°Werkzeuge	Lubrificazione int. opzionale Coolant through optional Innenkuehlung Optional	Lubrificazione est. Ext. coolant Aussenkuehlung	D
MNL0182500	3+3	X	X	25
MNL0182540	3+3	X	X	1"

MT RENT  
 MT CUT T25Y/SY - MT CUT T32Y/SY

PORTAUTENSILE ASSIALE PER BARENO 3+3 POSIZIONI Ø25mm / Ø1"  
 Axial 3+3 position boring bar holder Ø25mm / Ø1"  
 Axial Bohrhalter 3+3 Positionen Ø25mm / Ø1"

Subject to change without notice.

**M.T. srl**

Via Casino Albini 480  
 Tel. 0541/956034-957884  
 Fax 0541/956341  
 47842 S. GIOVANNI IN M. (RN)  
 e-mail: mtma@mtmarchetti.com  
 http://www.mtmarchetti.com

PRODUZIONE MODULI ROTANTI



PAGINA MTR894-1-00

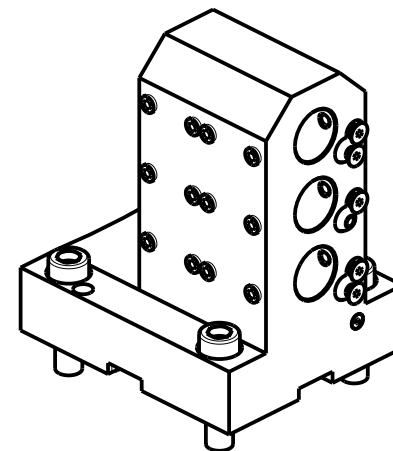
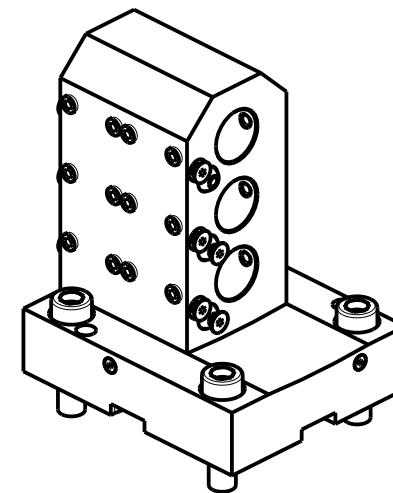
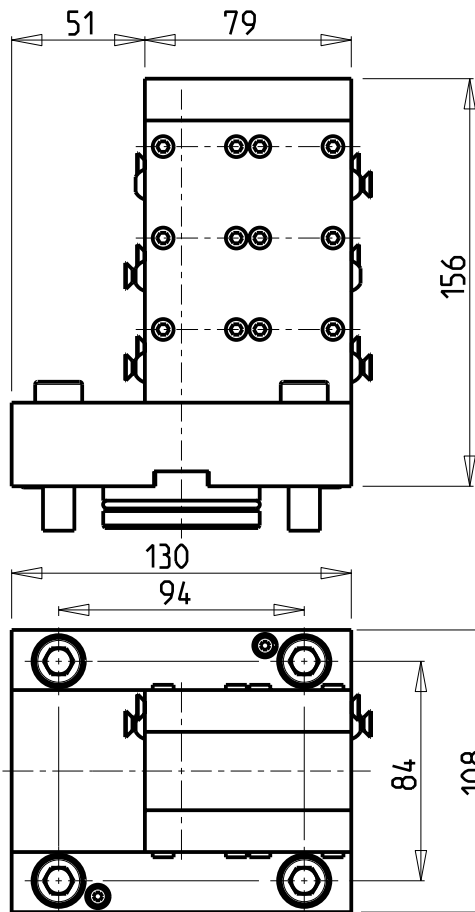
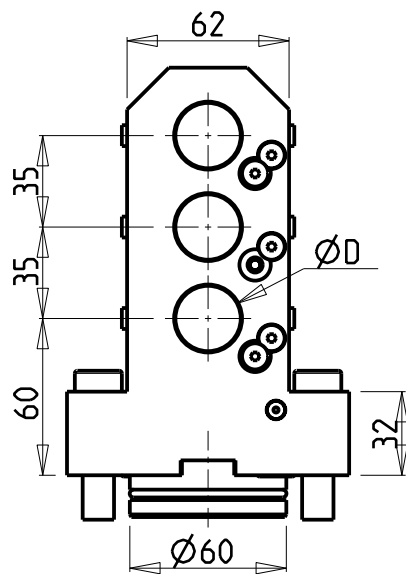

PER BOCCOLE DI RIDUZIONE VEDI PAG. TBL150-1-00  
 FOR REDUCING BUSHINGS SEE PAGE TBL150-1-00  
 FÜR REDUZIERBUCHSE SIEHE SEITE TBL150-1-00

Cod. MT	N°Utensili N°Tools N°Werkzeuge	Reversibile lato mandrino/contromandrino Reversible sub/main spindle side Umkehrbare Spindel-seite/ Gegenspindel-seite	Lubrificazione est. Ext. coolant Aussenkuehlung	D
MNL0192500	3	X	X	25
MNL0192540	3	X	X	1"

MT RENT  
 MT CUT T25Y/SY - MT CUT T32Y/SY

PORTAUTENSILE ASSIALE ARRETRATO PER BARENO 3 POSIZIONI Ø25mm / Ø1"  
 Axial 3 position rear set boring bar holder Ø25mm / Ø1"  
 Axial Bohrhälter 3 Positionen zurueckversetzt Ø25mm / Ø1"

Subject to change without notice.

**M.T. srl**

Via Casino Albini 480  
 Tel. 0541/956034-957884  
 Fax 0541/956341  
 47842 S. GIOVANNI IN M. (RN)  
 e-mail: mtma@mtmarchetti.com  
 http://www.mtmarchetti.com

PRODUZIONE MODULI ROTANTI



PAGINA MTR904-1-00

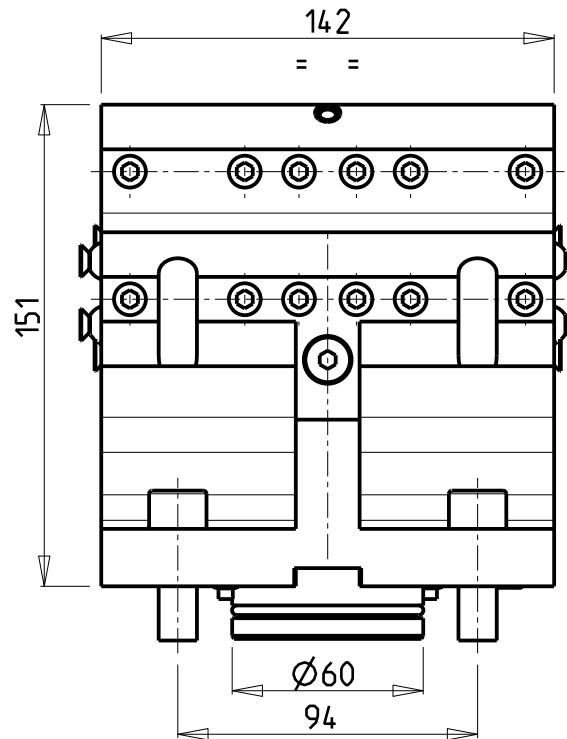
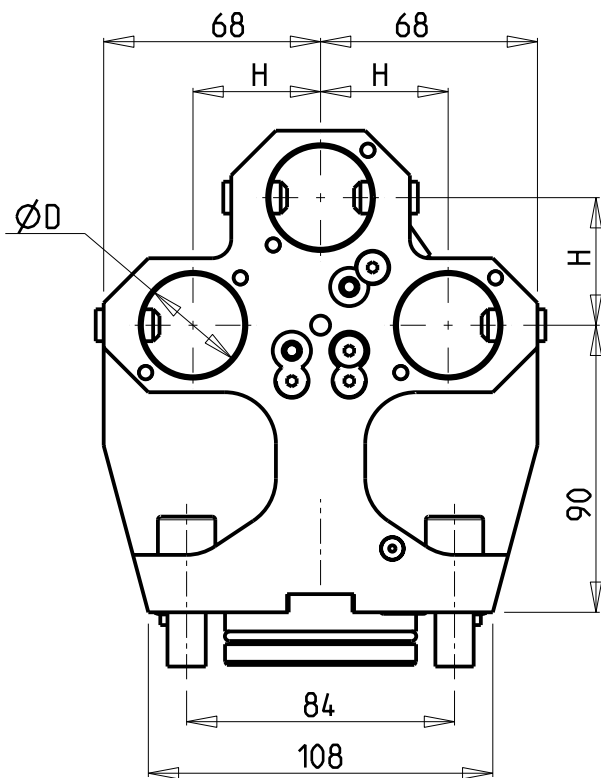

KIT ADDUZIONE INTERNA (OPZIONALE)  
 KIT FOR INTERNAL COOLANT (OPTIONAL)  
 KIT FUER INTERNE KUEHLMITTELZUFUHR (OPTIONAL)  
 cod. KIT1000001

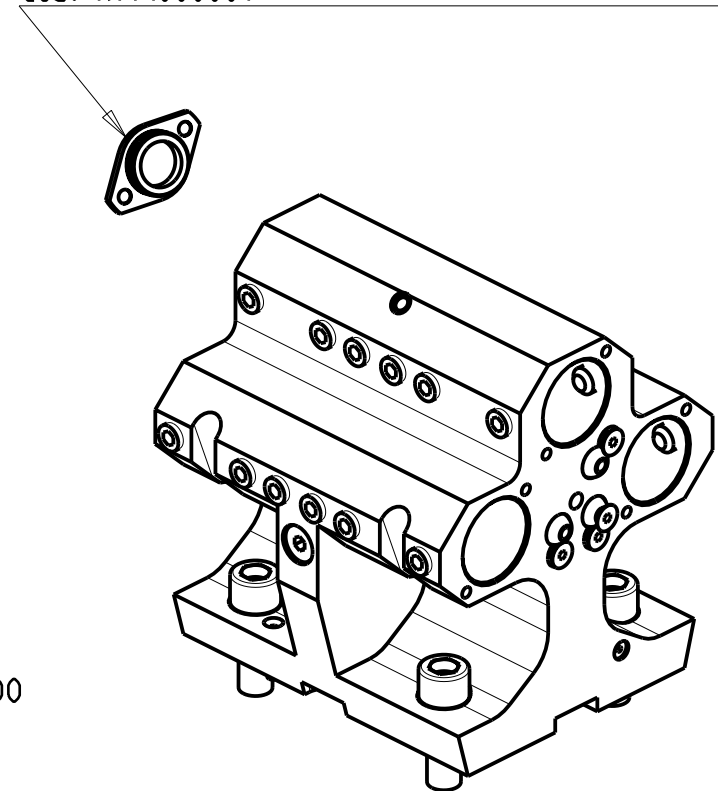

PER BOCCOLE DI RIDUZIONE VEDI PAG. TBL150-1-00  
 FOR REDUCING BUSHINGS SEE PAGE TBL150-1-00  
 FUR REDUZIERBUCHSE SIEHE SEITE TBL150-1-00

Cod. MT	N°Utensili N°Tools N°Werkzeuge	Lubrificazione int. Coolant through Innenkuehlung	Lubrificazione est. Ext. coolant Aussenkuehlung	Misure Dimensions Masse	D	H
MNL0093200	3+3	X	X	mm	32	40
MNL0093175	3+3	X	X	Inch	1 1/4"	1 1/2"

MT RENT  
 MT CUT T25Y/SY - MT CUT T32Y/SY

PORTAUTENSILE ASSIALE PER BARENO 3+3 POSIZIONI Ø32mm / Ø1 1/4"  
 Axial 3+3 position boring bar holder Ø32mm / Ø1 1/4"  
 Axial Bohrhalter 3+3 Positionen Ø32mm / Ø1 1/4"

Subject to change without notice.

**M.T. srl**  
 Via Casino Albini 480  
 Tel. 0541/956034-957884  
 Fax 0541/956341  
 47842 S. GIOVANNI IN M. (RN)  
 e-mail: mtma@mtmarchetti.com  
 http://www.mtmarchetti.com

PRODUZIONE MODULI ROTANTI



PAGINA MTR912-1-00

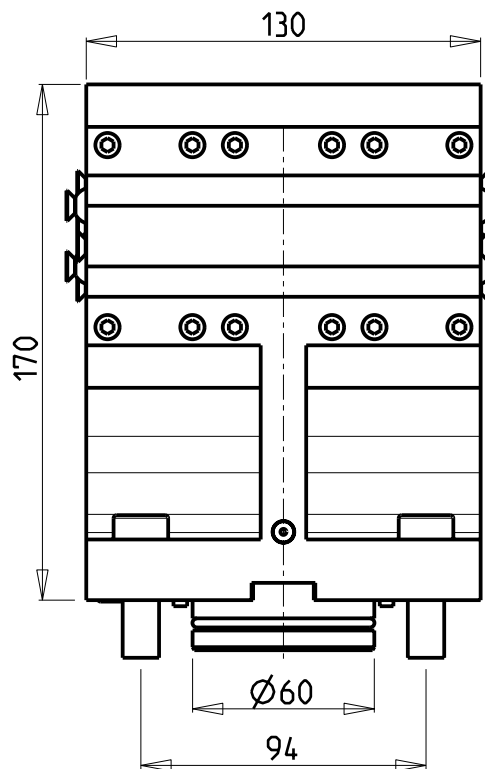
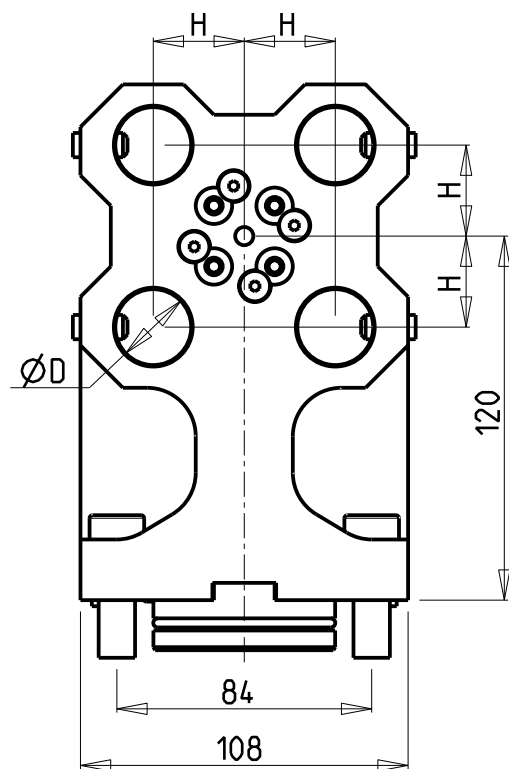

**ATTENZIONE - ATTENTION - ACHTUNG**

- VERIFICARE LE MISURE DI INGOMBRO PER POSSIBILE INTERFERENZA
- Please check the overall sizes for possible interferences
- Bitte überprüfen sie das Ausmass um mögliche Interferenzen zu vermeiden

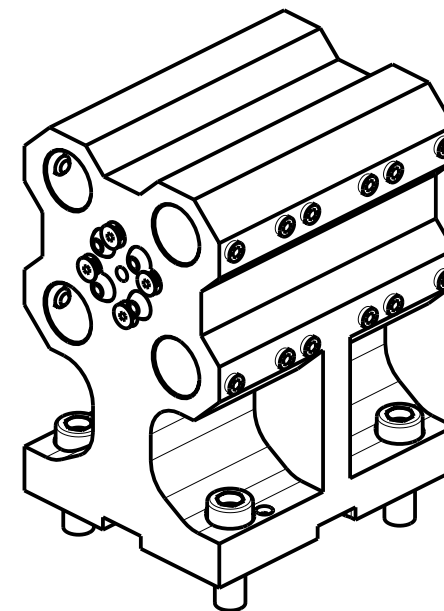

PER BOCCOLE DI RIDUZIONE VEDI PAG. TBL150-1-00  
 FOR REDUCING BUSHINGS SEE PAGE TBL150-1-00  
 FÜR REDUZIERBUCHSE SIEHE SEITE TBL150-1-00

Cod. MT	N°Utensili N°Tools N°Werkzeuge	Lubrificazione est. Ext. coolant Aussenkuehlung	Misure Dimensions Masse	D	H
MNL0082500	4+4	X	mm	25	30
MNL0082540	4+4	X	Inch	1"	1 1/4"

MT RENT  
 MT CUT T25Y/SY - MT CUT T32Y/SY

PORTAUTENSILE ASSIALE PER BARENO 4+4 POSIZIONI Ø25mm / Ø1"  
 Axial 4+4 position boring bar holder Ø25mm / Ø1"  
 Axial Bohrhälter 4+4 Positionen Ø25mm / Ø1"

Subject to change without notice.

**M.T. srl**  
 Via Casino Albini 480  
 Tel. 0541/956034-957884  
 Fax 0541/956341  
 47842 S. GIOVANNI IN M. (RN)  
 e-mail: mtma@mtmarchetti.com  
 http://www.mtmarchetti.com

PRODUZIONE MODULI ROTANTI



PAGINA MTR922-1-00



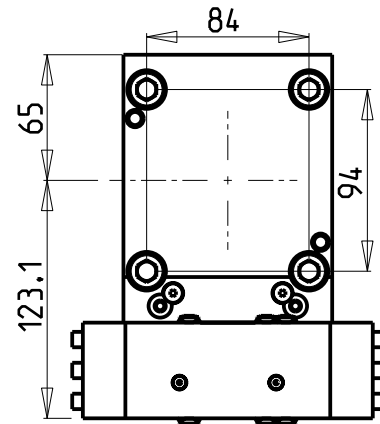
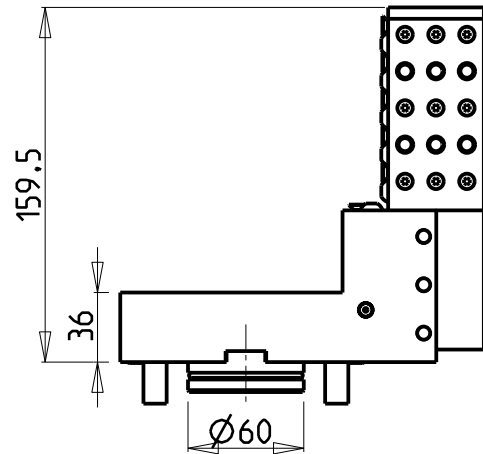
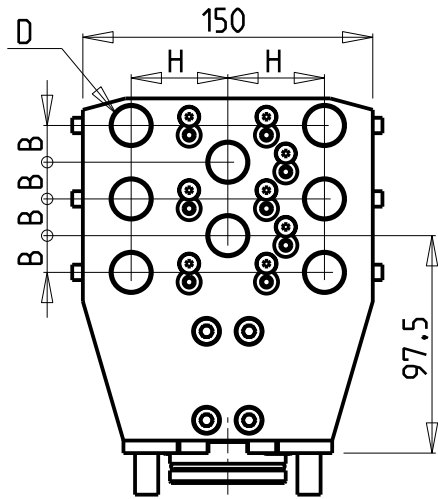

### DOTAZIONI - SUPPLIED WITH - AUSSTATTUNG

<b>mm</b>	N*5 Boccole - Bushings - Buchsen Ø16-12-10-8-6 N*1 ER16 Portapinza - Collet holder - Zangenhalter N*1 ER25 Portapinza - Collet holder - Zangenhalter
<b>inch</b>	N*3 Boccole - Bushings - Buchsen Ø1/2"-3/8"-1/4" N*1 ER16 Portapinza - Collet holder - Zangenhalter N*1 ER25 Portapinza - Collet holder - Zangenhalter

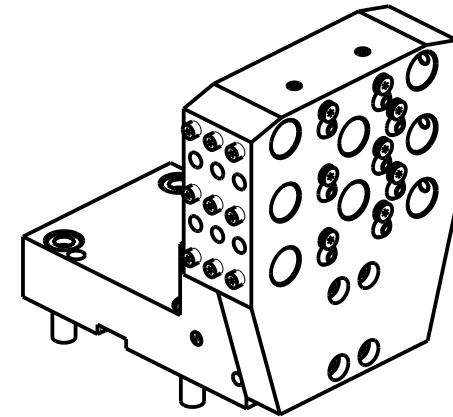

### ATTENZIONE - ATTENTION - ACHTUNG

- VERIFICARE LE MISURE DI INGOMBRO PER POSSIBILE INTERFERENZA
- Please check the overall sizes for possible interferences
- Bitte überprüfen sie das Ausmass um mögliche Interferenzen zu vermeiden

Cod. MT	N°Utensili N°Tools N°Werkzeuge	Reversibile lato mandrino/contromandrino Reversible sub/main spindle side Umkehrbare Spindel-seite/ Gegenspindel-seite	Lubrificazione est. Ext. coolant Aussenkuehlung	Misure Dimensions Masse	D	B	H
MNL0122000	8	X	X	mm	20	16	50
MNL0121905	8	X	X	Inch	3/4"	5/8"	2"

MT RENT

MT CUT T25Y/SY - MT CUT T32Y/SY

PORTAUTENSILE ASSIALE PER BARENO 8 POSIZIONI Ø20mm / Ø3/4"

Axial 8 position boring bar holder Ø20mm / Ø3/4"

Axial Bohrhälter 8 Positionen Ø20mm / Ø3/4"

Subject to change without notice.

**M.T. srl**

Via Casino Albini 480  
Tel. 0541/956034-957884  
Fax 0541/956341  
47842 S. GIOVANNI IN M. (RN)  
e-mail: mtma@mtmarchetti.com  
http://www.mtmarchetti.com

PRODUZIONE MODULI ROTANTI



PAGINA MTR933-1-00

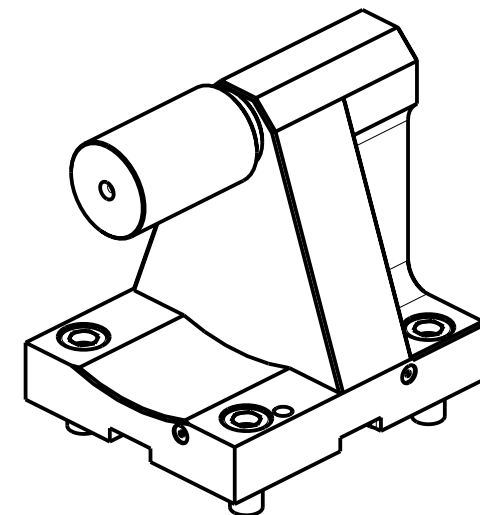
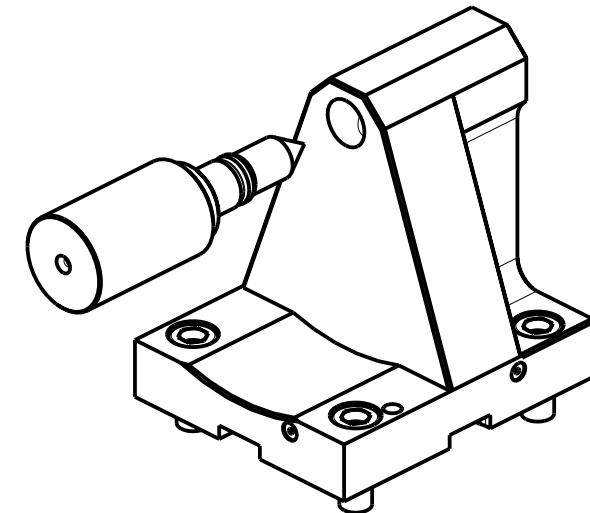
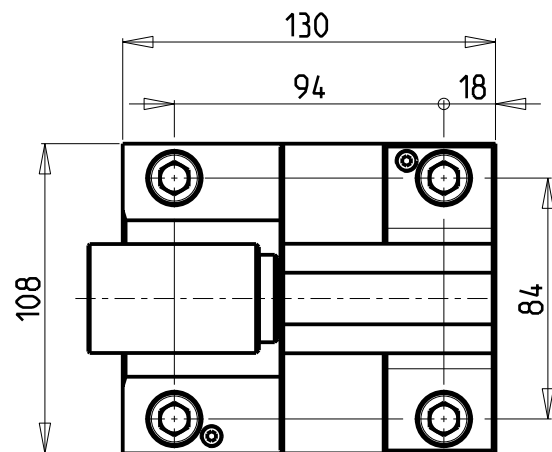
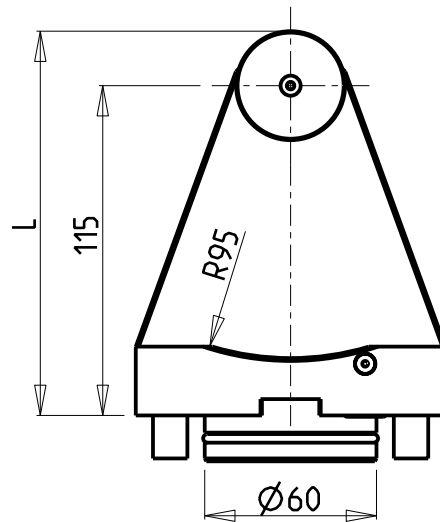
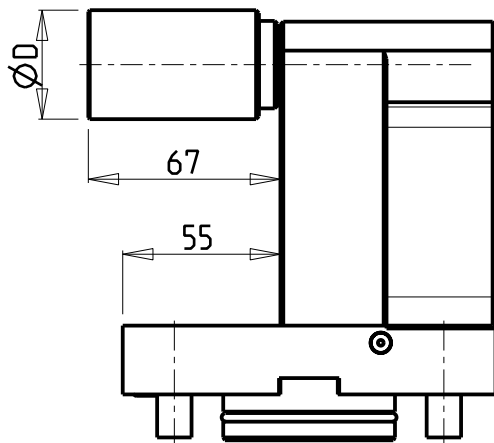

Cod. MT	N°Utensili N°Tools N°Werkzeuge	Reversibile lato mandrino/contromandrino Reversible sub/main spindle side Umkehrbare Spindel-seite/ Gegenspindel-seite	D	L
MNL0360100	1	X	38	134
MNL0360100L	1	X	2"	140.4

MT RENT  
MT CUT T25Y/SY - MT CUT T32Y/SY

CONTROPUNTA PER CONTROMANDRINO  
Tailstock for subspindle  
Gegenspintz fuer Gegenspindel

Subject to change without notice.

**M.T. srl**

Via Casino Albini 480  
Tel. 0541/956034-957884  
Fax 0541/956341  
47842 S. GIOVANNI IN M. (RN)  
e-mail: mtma@mtmarchetti.com  
http://www.mtmarchetti.com

PRODUZIONE MODULI ROTANTI



PAGINA MTR950-1-00