

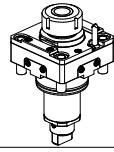

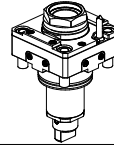
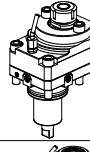
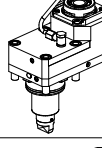
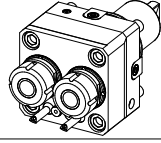
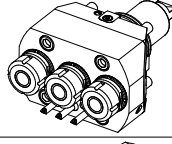
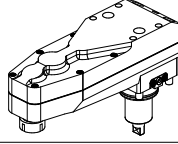
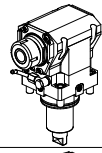
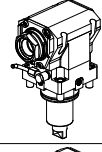
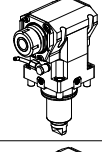
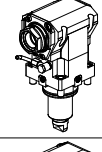
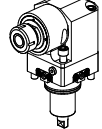

		PAGINA Page Seite
MODULO MOTORIZZATO RADIALE MAGGIORATO Radial reinforced driven tool Radial angetriebenes Werkzeug vergrößert		GDW 020.4.01
MODULO MOTORIZZATO RADIALE MAGGIORATO MTSK Radial MTSK reinforced driven tool Radial MTSK angetriebenes Werkzeug vergrößert		GDW 020.4.01.K
MODULO MOTORIZZATO RADIALE MOLTIPLICATO 1=1:2 DISASSATO IN Z 36mm Radial geared-up 1=1:2 driven tool re-directed in Z by 36mm Radial angetriebenes Werkzeug uebersetzt 1=1:2 achsversetzt in Z um 36mm		GDW 030.4.30
MODULO MOTORIZZATO RADIALE RIDOTTO 1=2:1 DISASSATO IN Z 80mm Radial geared-down 1=2:1 driven tool re-directed in Z by 80mm Radial angetriebenes Werkzeug untersetzt 1=2:1 achsversetzt in Z um 80mm		GDW 033.4.20
MODULO MOTORIZZATO RADIALE 2 USCITE IN Y Radial single side twin head driven tool in Y Radial angetriebenes Werkzeug 2 Ausgaenge in Y		GDW 080.4.00
MODULO MOTORIZZATO RADIALE 3 USCITE IN Y Radial single side 3 outlet driven tool in Y Radial angetriebenes Werkzeug 3 Ausgaenge in Y		GDW 095.4.00
MODULO MOTORIZZATO RADIALE ROVESCiato DISASSATO IN Z 250mm Radial inverted driven tool re-directed in Z by 250mm Radial angetriebenes Werkzeug ungekehrt achsversetzt in Z um 250mm		GDW 120.4.10
MODULO MOTORIZZATO ASSIALE H=85mm Axial driven tool H=85mm Axial angetriebenes Werkzeug H=85mm		GDW 150.4.15
MODULO MOTORIZZATO ASSIALE MTSK H=85mm Axial MTSK driven tool H=85mm Axial MTSK angetriebenes Werkzeug H=85mm		GDW 150.4.15.K
MODULO MOTORIZZATO ASSIALE H=95mm Axial driven tool H=95mm Axial angetriebenes Werkzeug H=95mm		GDW 150.4.18
MODULO MOTORIZZATO ASSIALE MTSK H=95mm Axial MTSK driven tool H=95mm Axial MTSK angetriebenes Werkzeug H=95mm		GDW 150.4.18.K
MODULO MOTORIZZATO ASSIALE H=100mm Axial driven tool H=100mm Axial angetriebenes Werkzeug H=100mm		GDW 150.4.20

		PAGINA Page Seite
MODULO MOTORIZZATO ASSIALE H=100mm Axial driven tool H=100mm Axial angetriebenes Werkzeug H=100mm		GDW 150.4.21
MODULO MOTORIZZATO ASSIALE MTSK H=100mm Axial MTSK driven tool H=100mm Axial MTSK angetriebenes Werkzeug H=100mm		GDW 150.4.21.K
MODULO MOTORIZZATO ASSIALE MAGGIORATO H=85mm Axial reinforced driven tool H=85mm Axial angetriebenes Werkzeug vergrößert H=85mm		GDW 170.4.20
MODULO MOTORIZZATO ASSIALE MAGGIORATO MTSK H=85mm Axial MTSK reinforced driven tool H=85mm Axial MTSK angetriebenes Werkzeug vergrößert H=85mm		GDW 170.4.20.K
MODULO MOTORIZZATO ASSIALE MAGGIORATO H=95mm Axial reinforced driven tool H=95mm Axial angetriebenes Werkzeug vergrößert H=95mm		GDW 170.4.25
MODULO MOTORIZZATO ASSIALE MAGGIORATO MTSK H=95mm Axial MTSK reinforced driven tool H=95mm Axial MTSK angetriebenes Werkzeug vergrößert H=95mm		GDW 170.4.25.K
MODULO MOTORIZZATO ASSIALE MAGGIORATO H=100mm Axial reinforced driven tool H=100mm Axial angetriebenes Werkzeug vergrößert H=100mm		GDW 170.4.30
MODULO MOTORIZZATO ASSIALE MAGGIORATO MTSK H=100mm Axial MTSK reinforced driven tool H=100mm Axial MTSK angetriebenes Werkzeug vergrößert H=100mm		GDW 170.4.30.K
MODULO MOTORIZZATO ASSIALE ARRETRATO H=95mm Axial rear-set driven tool H=95mm Axial angetriebenes Werkzeug zurückversetzt H=95mm		GDW 180.4.25 
MODULO MOTORIZZATO ASSIALE RIDOTTO l=2:1 H=100mm Axial geared-down l=2:1 driven tool H=100mm Axial angetriebenes Werkzeug untersetzt l=2:1 H=100mm		GDW 190.4.30
MODULO MOTORIZZATO ASSIALE MOLTIPLICATO l=1:2 Axial geared-up l=1:2 driven tool Axial angetriebenes Werkzeug übersetzt l=1:2		GDW 200.4.20
MODULO MOTORIZZATO ASSIALE BISPORGENTE H=85mm Axial opposite face driven tool H=85mm Axial angetriebenes Werkzeug halb vorspringend H=85mm		GDW 240.4.15

		PAGINA Page Seite
MODULO MOTORIZZATO ASSIALE BISPORGENTE H=95mm Axial opposite face driven tool H=95mm Axial angetriebenes Werkzeug halb vorspringend H=95mm		GDW 240.4.18
MODULO MOTORIZZATO ASSIALE BISPORGENTE H=100mm Axial opposite face twin driven tool H=100mm Axial angetriebenes Werkzeug halb vorspringend H=100mm		GDW 240.4.20
MODULO MOTORIZZATO ASSIALE BISPORGENTE H=100mm Axial opposite face driven tool H=100mm Axial angetriebenes Werkzeug halb vorspringend H=100mm		GDW 240.4.21
MODULO MOTORIZZATO ASSIALE 2 USCITE IN Y H=100mm Axial single side twin head driven tool in Y H=100mm Axial angetriebenes Werkzeug 2 Ausgaenge in Y H=100mm		GDW 260.4.30
MODULO MOTORIZZATO ORIENTABILE ±90° H=54mm ±90° adjustable angle driven tool H=54mm Angetriebenes Werkzeug schwenkbar ±90° H=54mm		GDW 333.4.00
MODULO MOTORIZZ. ORIENTABILE ±90° CON NONIO DIGITALE H=54mm ±90° adjustable angle driven tool with digital display H=54mm Angetriebenes Werkzeug schwenkbar ±90° mit digital display H=54mm		GDW 333.4.01
MODULO MOTORIZZATO ORIENTABILE ±90° H=100mm ±90° adjustable angle driven tool H=100mm Angetriebenes Werkzeug schwenkbar ±90° H=100mm		GDW 333.4.10
MODULO MOTORIZZ. ORIENTABILE ±90° CON NONIO DIGITALE H=100mm ±90° adjustable angle driven tool with digital display H=100mm Angetriebenes Werkzeug schwenkbar ±90° mit digital display H=100mm		GDW 333.4.11
MODULO MOTORIZZATO ORIENTABILE ±90° H=72mm ±90° adjustable angle driven tool H=72mm Angetriebenes Werkzeug schwenkbar ±90° H=72mm		GDW 335.4.00
MODULO MOTORIZZ. ORIENTABILE ±90° CON NONIO DIGITALE H=72mm ±90° adjustable angle driven tool with digital display H=72mm Angetriebenes Werkzeug schwenkbar ±90° mit digital display H=72mm		GDW 335.4.01
MODULO MOTORIZZATO ORIENTABILE ±90° MOLTIPLICATO I=1:2 H=72mm ±90° adjustable angle driven tool geared-up I=1:2 H=72mm Angetriebenes Werkzeug schwenkbar ±90° uebersetzt I=1:2 H=72mm		GDW 336.4.00
MOD. MOT. ORIENTABILE ±90° MOLTIPL. I=1:2 CON NONIO DIGIT. H=72mm ±90° adjustable angle driven tool geared-up I=1:2 with digital display H=72mm Angetr. Werkzeug schwenkbar ±90° uebersetzt I=1:2 mit digital display H=72mm		GDW 336.4.01

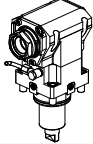
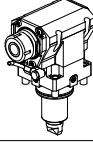
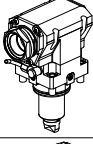
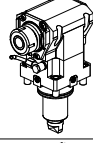
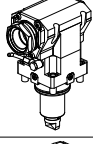
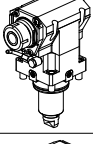
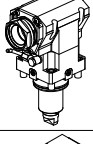
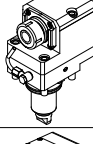
		PAGINA Page Seite
MODULO MOTORIZZATO PORTACREATORE Driven gear hobber Angetriebenes Zahnradwaelzfraes-Werkzeug		GDW 340.4.00
MODULO MOTORIZZATO ASSIALE MTSK PER POWER SKIVING H=100mm Axial MTSK driven tool for Power Skiving H=100mm Axial MTSK angetriebenes Werkzeug fuer Power Skiving H=100mm		GDW 350.4.00.K
MODULO MOTORIZZATO STOZZATORE CORSA 50mm H=85mm Slotting driven tool 50mm stroke H=85mm Keilnutenstossmaschine 50mm Hub H=85mm		GDW 360.4.00
MODULO MOTORIZZATO STOZZATORE CORSA 25mm H=85mm Slotting driven tool 25mm stroke H=85mm Keilnutenstossmaschine 25mm Hub H=85mm		GDW 360.4.01
MODULO MOTORIZZATO STOZZATORE CORSA 50mm H=100mm Slotting driven tool 50mm stroke H=100mm Keilnutenstossmaschine 50mm Hub H=100mm		GDW 360.4.10
MODULO MOTORIZZATO STOZZATORE CORSA 25mm H=100mm Slotting driven tool 25mm stroke H=100mm Keilnutenstossmaschine 25mm Hub H=100mm		GDW 360.4.11
MODULO MOTORIZZATO PER LUNETTA RETRATTILE (TAGLIA 2) Driven toolholder for sliding steady rest (Size 2) Luenettenwerkzeug zurueck versetzte Version (Groesse 2)		GDW 363.4.00
PORTAUTENSILE RADIALE SINGOLO QD=25mm / QD=1" H=90mm Radial single static tool QD=25mm / QD=1" H=90mm Radial Single-Werkzeughalter QD=25mm / QD=1" H=90mm		GDW 423.4.00
PORTAUTENSILE RADIALE SINGOLO QD=25mm / QD=1" H=75mm Radial single static tool QD=25mm / QD=1" H=75mm Radial Single-Werkzeughalter QD=25mm / QD=1" H=75mm		GDW 423.4.10
PORTAUTENSILE RADIALE DOPPIO QD=25mm / QD=1" H=90mm Radial double static tool QD=25mm / QD=1" H=90mm Radial Doppel-Werkzeughalter QD=25mm / QD=1" H=90mm		GDW 453.4.00
PORTAUTENSILE RADIALE DOPPIO QD=25mm H=75mm Radial double static tool QD=25mm H=75mm Radial Doppel-Werkzeughalter QD=25mm H=75mm		GDW 453.4.10
PORTAUTENSILE RADIALE DOPPIO SOVRAPPOSTO QD=25mm / QD=1" Radial double side twin static tool QD=25mm / QD=1" Radial Doppel-Werkzeughalter ueberlagert QD=25mm / QD=1"		GDW 463.4.00

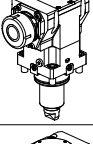
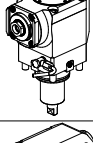
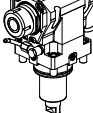
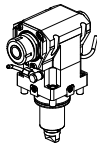
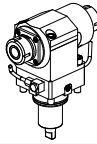
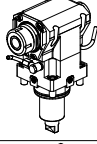
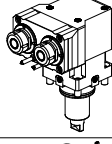
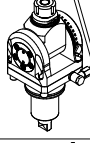
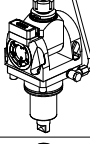
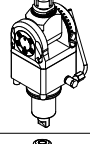
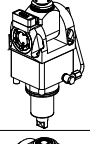
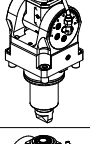
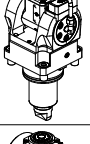
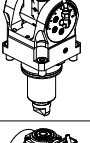
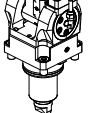
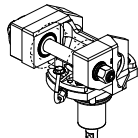
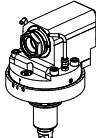
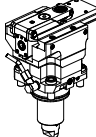
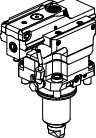
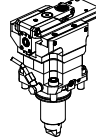
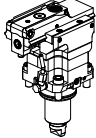
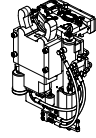
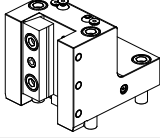
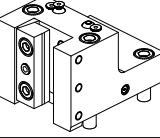
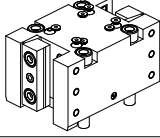
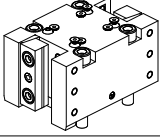
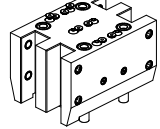
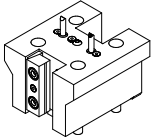
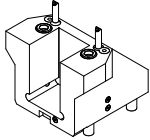
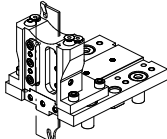
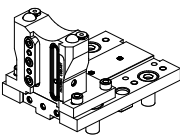
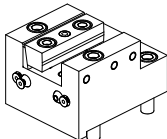
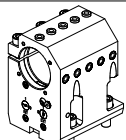
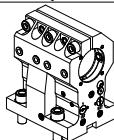
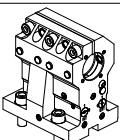
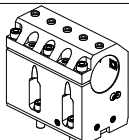
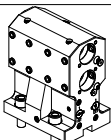
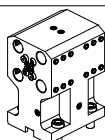
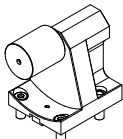
		PAGINA Page Seite
<p>PORTAUT. RADIALE DOPPIO QD=25mm CON SEDE ATTACCO MT CAPTO Radial double static tool QD=25mm with seat for MT CAPTO connection Radial Doppel-Werkzeughalter QD=25mm mit Sitz fuer MT CAPTO Anschluss</p>		GDW 495.4.00
<p>PORTAUTENSILE RADIALE CON SEDE ATTACCO MT CAPTO Radial tool with seat for MT CAPTO connection Radial Single-Werkzeughalter mit Sitz fuer MT CAPTO Anschluss</p>		GDW 500.4.00
<p>PORTAUTENSILE RADIALE PER LAMA Radial blade holder Radial Abstechhalter</p>		GDW 520.4.01
<p>PORTAUTENSILE RADIALE PER LAMA CON LUBRIFICAZIONE INTERNA Radial blade holder with internal coolant Radial Abstechhalter mit Innenkuehlung</p>		GDW 520.4.05
<p>PORTAUTENSILE ASSIALE SINGOLO QD=25mm / QD=1" Axial single static tool QD=25mm / QD=1" Axial Single-Werkzeughalter QD=25mm / QD=1"</p>		GDW 552.4.00
<p>PORTAUTENSILE ASSIALE PER BARENO Ø60mm H=100mm Axial single boring bar holder Ø60mm H=100mm Axial Bohrhalter Ø60mm H=100mm</p>		GDW 590.4.20
<p>PORTAUTENSILE ASSIALE PER BARENO Ø50mm H=100mm Axial single boring bar holder Ø50mm H=100mm Axial Bohrhalter Ø50mm H=100mm</p>		GDW 620.4.20
<p>PORTAUTENSILE ASSIALE PER BARENO Ø40mm H=100mm Axial single boring bar holder Ø40mm H=100mm Axial Bohrhalter Ø40mm H=100mm</p>		GDW 640.4.20
<p>PORTAUTENSILE ASSIALE PER BARENO Ø60mm H=100mm Axial single boring bar holder Ø60mm H=100mm Axial Bohrhalter Ø60mm H=100mm</p>		GDW 720.4.20
<p>PORTAUTENSILE ASSIALE PER BARENO 2 POSIZIONI Ø32mm Axial double boring bar holder Ø32mm Axial Bohrhalter 2 Positionen Ø32mm</p>		GDW 862.4.00
<p>PORTAUTENSILE ASSIALE PER BARENO 4+4 POSIZIONI Ø 20mm/Ø 3/4" Axial 4+4 position boring bar holder Ø20mm/Ø3/4" Axial Bohrhalter 4+4 Positionen Ø20mm/Ø3/4"</p>		GDW 924.4.00
<p>CONTROPUNTA PER CONTROMANDRINO Tailstock for subspindle Gegenspitz fuer Gegenspindel</p>		GDW 950.4.00

		PAGINA Page Seite
PORTAUTENSILE RADIALE SINGOLO ARRETRATO MT CAPTO Radial single rear-set static tool MT CAPTO Radial Single-Werkzeughalter zurueckversetzt MT CAPTO		GDW 430.D.40

CUSCINETTI MAGGIORATI PER LAVORAZIONI PESANTI

Reinforced bearings for
heavy machining

Vergroesserte Lager fuer
schwerere Bearbeitungen

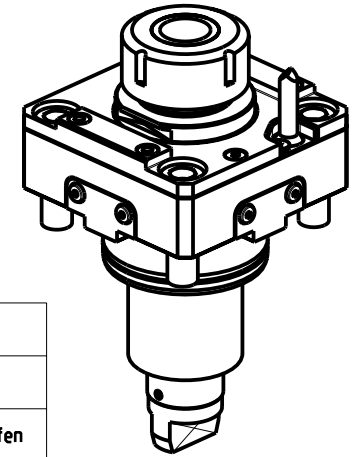
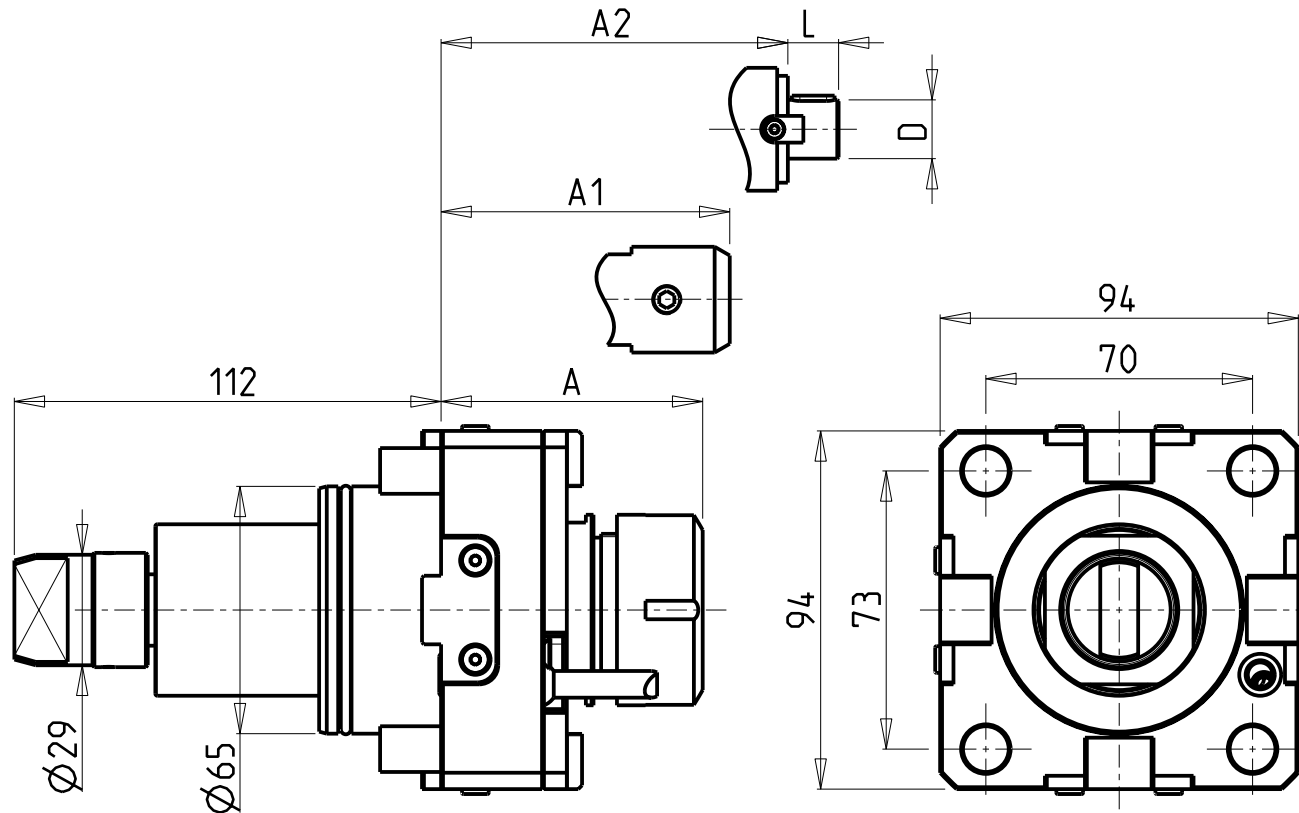

- Chiave inclusa
- Key included
- Schluessel inbegriffen

Cod. MT	Mandrino Spindle Spindel	I	RPM	Coppia Max Max Torque Max Drehmoment	Lubrificazione int. Coolant through Innenkuehlung	Lubrificazione est. Ext. coolant Aussenkuehlung	A	A1	A2	D	L	CHIAVI NON INCLUSE Keys not included Schluessel nicht einbegriffen	
DW 01540132	ER32	1:1	6000	100Nm	-	X	68.7	-	-	-	-	CHSTER32	OKU0650004
DW 01540232	ER32	1:1	6000	100Nm	P=30bar	X	79.2	-	-	-	-	CHSTER32	OKU0650004
DW 01540140	ER40	1:1	6000	100Nm	-	X	71.7	-	-	-	-	CHSTER40	OKU0650004
DW 01540240	ER40	1:1	6000	100Nm	P=30bar	X	82.2	-	-	-	-	CHSTER40	OKU0650004
DW 01540625	WELDON 25	1:1	6000	100Nm	P=30bar	X	-	72.5	-	-	-	-	OKU0650004
DW 01540827	Ø27x21	1:1	6000	100Nm	P=30bar	X	-	-	56.5	27	21	CH_VTCROCE_M12	OKU0650004

GOODWAY

MOD: GTX2000/2600 12ST. - GTZ2000/2600 12ST. - GS2000/2800 16ST. - GMT2000 - GMS2000 15ST. - GLS2800/3300 12ST.

MODULO MOTORIZZATO RADIALE MAGGIORATO

Radial reinforced driven tool

Radial angetriebenes Werkzeug vergroessert

Subject to change without notice.

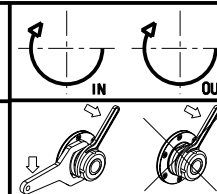

M.T. srl

Via Casino Albini 480
Tel. 0541/956034-957884
Fax 0541/956341
47842 S. GIOVANNI IN M. (RN)
e-mail: mtma@mtmarchetti.com
http://www.mtmarchetti.com

PRODUZIONE MODULI ROTANTI



PAGINA GDW020-4-01

CUSCINETTI MAGGIORATI PER LAVORAZIONI PESANTI

Reinforced bearings for
heavy machining

Vergroesserte Lager fuer
schwerere Bearbeitungen

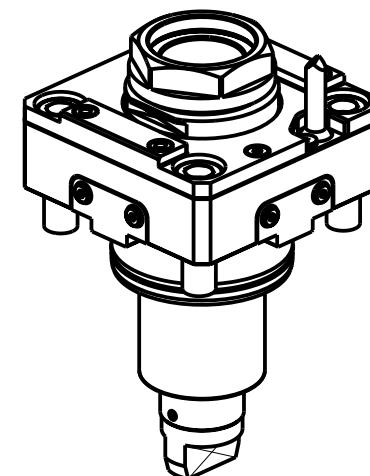
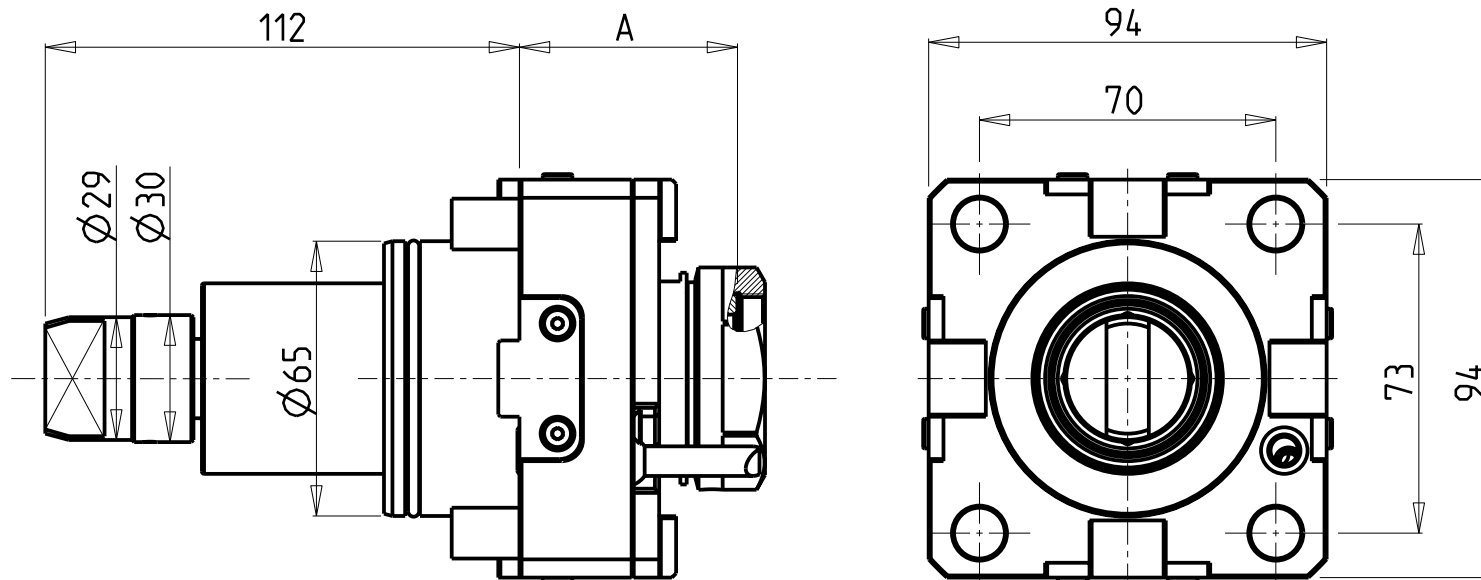

PER PORTAUTENSILI MODULARI MTSK-40 VEDI PAG. TBL300-1-40 E PER MTSK-50 VEDI PAG. TBL300-1-50
FOR MTSK-40 QUIK CHANGE TOOLHOLDERS CLAMPINGS SEE PAGE TBL300-1-40 AND FOR MTSK-50 SEE PAGE TBL300-1-50
FUER MTSK-40 MODULARE WERKZEUGAUFNAHMEN SIEHE SEITE TBL300-1-40 UND FUER MTSK-50 SIEHE SEITE TBL300-1-50

Cod. MT	Mandrino Spindle Spindel	I	RPM	Coppia Max Max Torque Max Drehmoment	Lubrificazione int. Coolant through Innenkuehlung	Lubrificazione est. Ext. coolant Aussenkuehlung	A	CHIAVI NON INCLUSE Keys not included Schlüssel nicht einbegriffen	
DW 01550140	MTSK-40	1:1	6000	100Nm	-	X	51.5	CHUB46	OKU0650004 ■
DW 01550240	MTSK-40	1:1	6000	100Nm	P=30bar	X	62.5	CHUB46	OKU0650004 ■
DW 01550150	MTSK-50	1:1	6000	100Nm	-	X	51.5	CHUB55	OKU0650004 ■
DW 01550250	MTSK-50	1:1	6000	100Nm	P=30bar	X	62.5	CHUB55	OKU0650004 ■

• Chiave inclusa
• Key included
• Schlüssel inbegriffen

GOODWAY

MOD: GTX2000/2600 12ST. - GTZ2000/2600 12ST. - GS2000/2800 16ST. - GMT2000 - GMS2000 15ST. - GLS2800/3300 12ST.

MODULO MOTORIZZATO RADIALE MAGGIORATO MTSK
Radial MTSK reinforced driven tool
Radial MTSK angetriebenes Werkzeug vergroessert

Subject to change without notice.

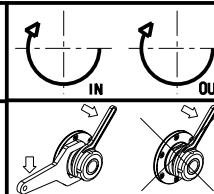

M.T. srl

Via Casino Albini 480
Tel. 0541/956034-957884
Fax 0541/956341
47842 S. GIOVANNI IN M. (RN)
e-mail: mtma@mtmarchetti.com
http://www.mtmarchetti.com

PRODUZIONE MODULI ROTANTI



PAGINA GDW 020-4-01-K

10/2018

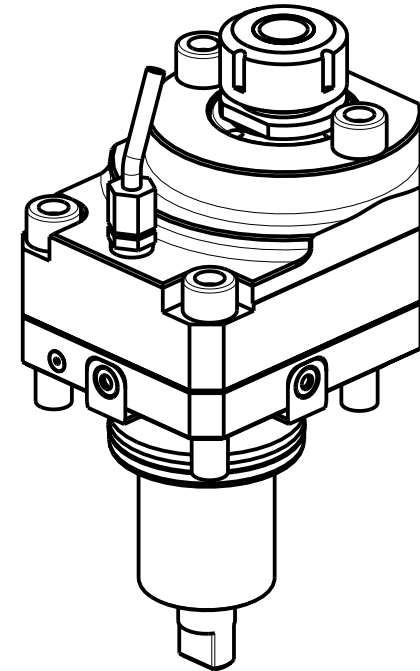
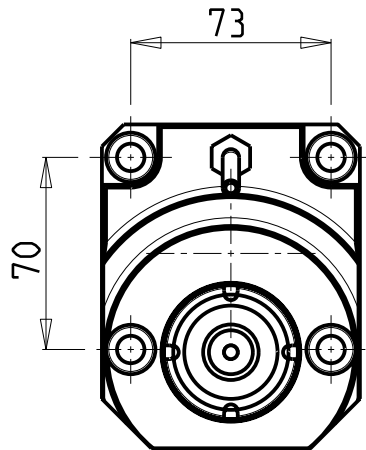
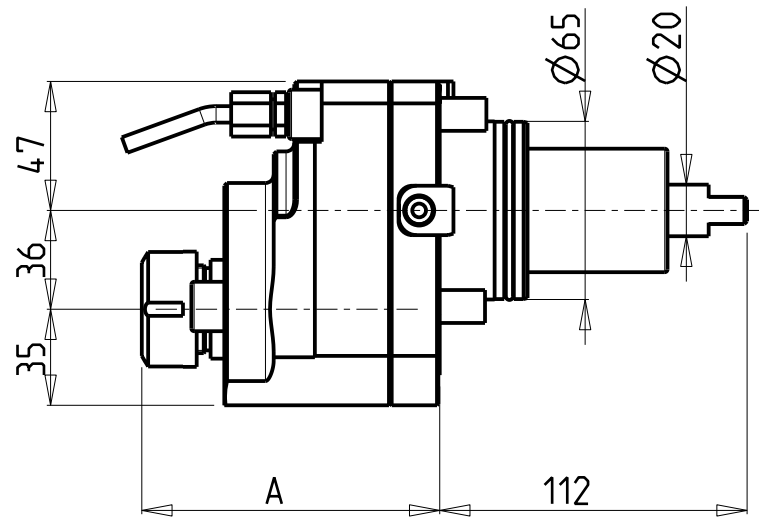
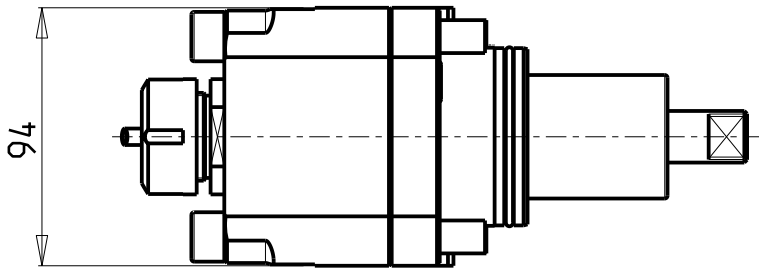

Cod. MT	Mandrino Spindle Spindel	I	RPM	Coppia Max Max Torque Max Drehmoment	Reversibile lato mandrino/contromandrino Reversible sub/main spindle side Umkehrbare Spindel-seite/ Gegenspindel-seite	Lubrificazione est. Ext. coolant Aussenkuehlung	A	CHIAVI NON INCLUSE Keys not included Schlüssel nicht einbegriffen
DW00140125	ER25	1:2	12000	30Nm	X	X	108.56	CHSTER25 MNL0210007

GOODWAY

MOD: GTX2000/2600 12ST. - GTZ2000/2600 12ST. - GS2000/2800 16ST. - GMT2000 - GMS2000 15ST. - GLS2800/3300 12ST.

MODULO MOTORIZZATO RADIALE MOLTIPLICATO I=1:2 DISASSATO IN Z 36mm

Radial geared-up I=1:2 driven tool re-directed in Z by 36mm

Radial angetriebenes Werkzeug uebersetzt I=1:2 achsversetzt in Z um 36mm

Subject to change without notice.

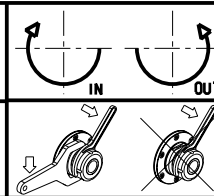

M.T. srl

Via Casino Albini 480
Tel. 0541/956034-957884

Fax 0541/956341

47842 S. GIOVANNI IN M. (RN)

e-mail: mtma@mtmarchetti.com

http://www.mtmarchetti.com

PRODUZIONE MODULI ROTANTI



PAGINA GDW030-4-30

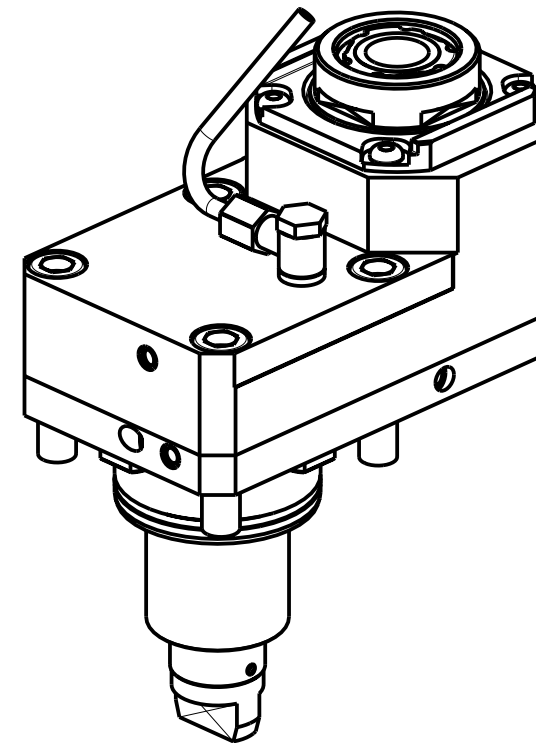
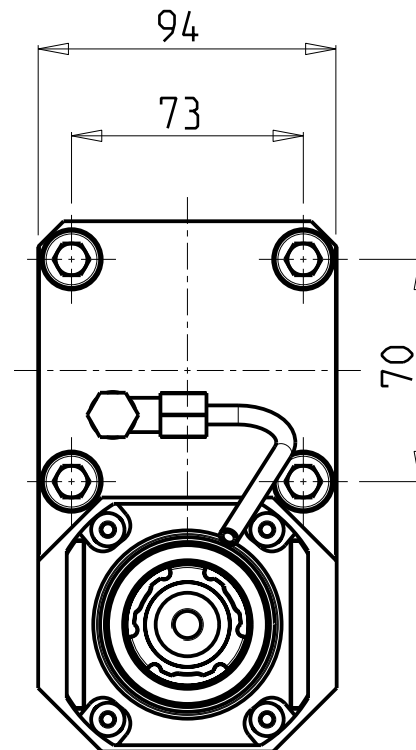
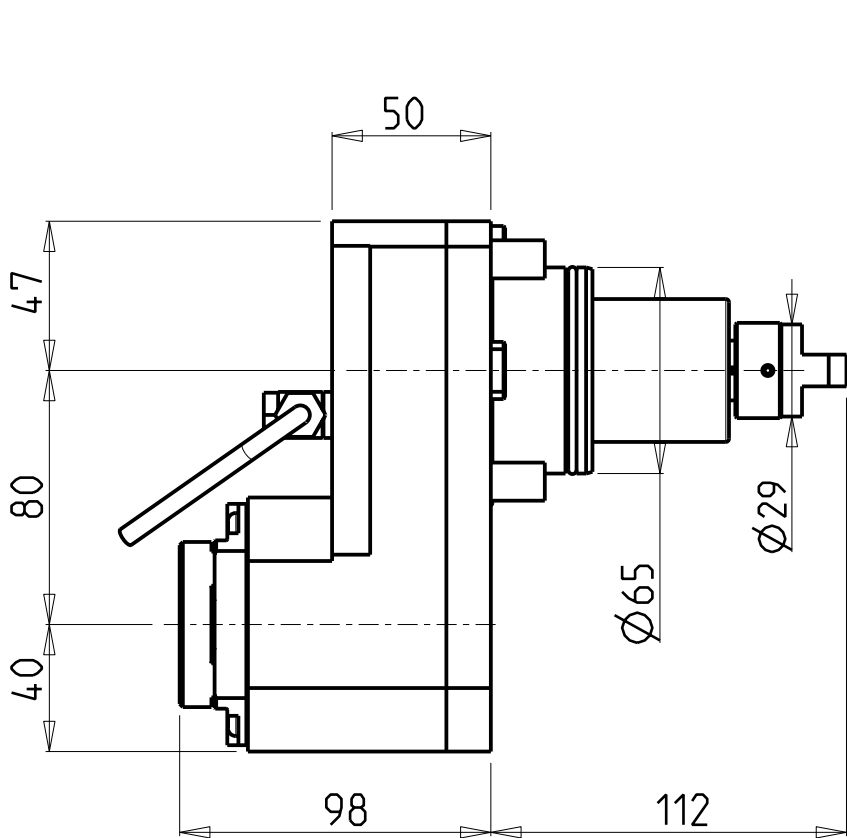

Cod. MT	Mandrino Spindle Spindel	I	RPM	Coppia Max Max Torque Max Drehmoment	Reversibile lato mandrino/contromandrino Reversible sub/main spindle side Umkehrbare Spindel-seite/ Gegenspindel-seite	Lubrificazione est. Ext. coolant Aussenkuehlung	CHIAVI NON INCLUSE Keys not included Schlüssel nicht einbegriffen		
DW01580332	ERA32	2:1	3000	90Nm	X	X	CHUB30	OKU0650004	CHTAER32ZC

- Chiave inclusa
- Key included
- Schlüssel inbegriffen

GOODWAY

MOD: GTX2000/2600 12ST. - GTZ2000/2600 12ST. - GS2000/2800 16ST. - GMT2000 - GMS2000 15ST. - GLS2800/3300 12ST.

MODULO MOTORIZZATO RADIALE RIDOTTO I=2:1 DISASSATO IN Z 80mm

Radial geared-down I=2:1 driven tool re-directed in Z by 80mm

Radial angetriebenes Werkzeug untersetzt I=2:1 achsversetzt in Z um 80mm

Subject to change without notice.

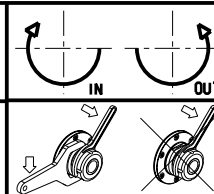

M.T. srl

Via Casino Albini 480
Tel. 0541/956034-957884
Fax 0541/956341
47842 S. GIOVANNI IN M. (RN)
e-mail: mtma@mtmarchetti.com
<http://www.mtmarchetti.com>

PRODUZIONE MODULI ROTANTI



PAGINA GDW033-4-20

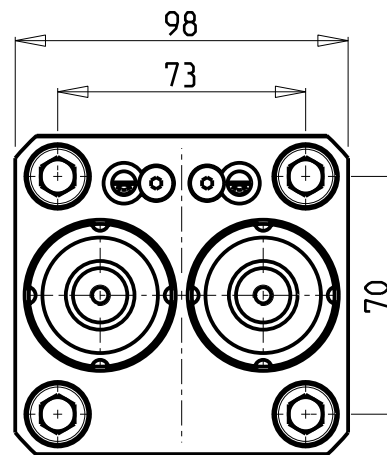
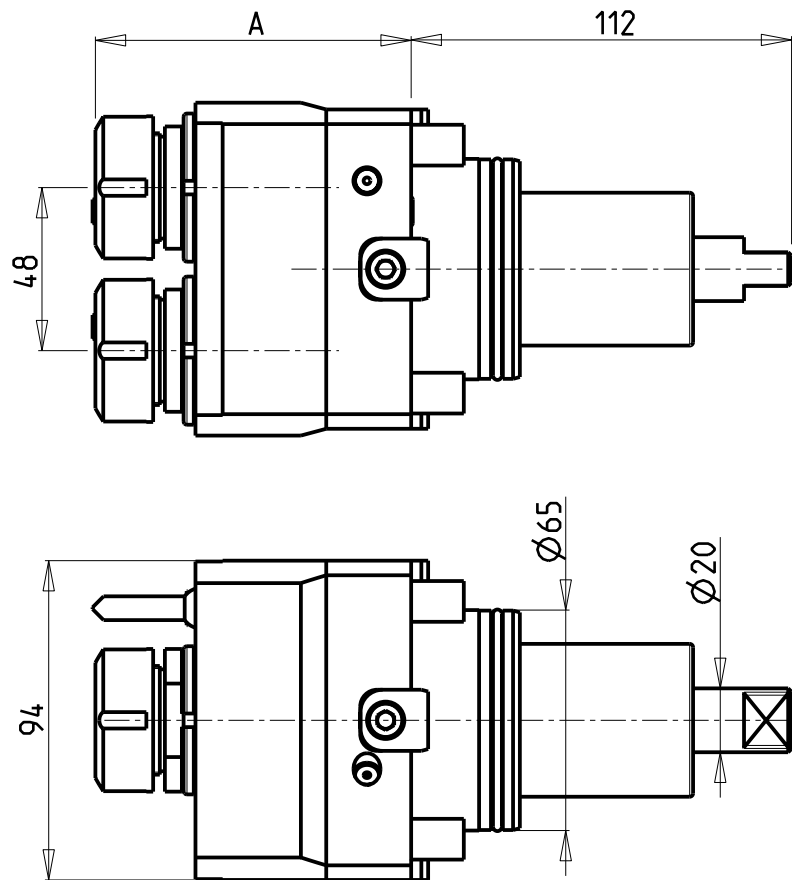

ATTENZIONE - ATTENTION - ACHTUNG

- Per lo smontaggio degli utensili utilizzare sempre la chiave di contrasto come indicato nel manuale d'uso.
- For disassembly of the tools use always the contrast key as mentioned in the user instructions.
- Fuer das Abmontieren der Werkzeuge immer den Gegenschlüssel benutzen wie in der Bedienungsanleitung erwäehnt.

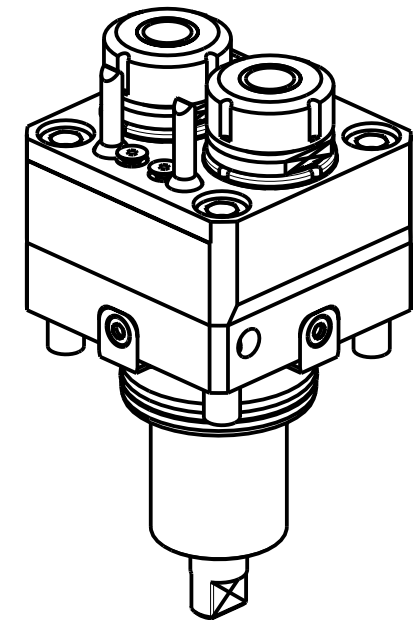

Cod. MT	Mandrino Spindle Spindel	I	RPM	Coppia Max Max Torque Max Drehmoment	Lubrificazione est. Ext. coolant Aussehenkuehlung	A	CHIAVI NON INCLUSE Keys not included Schlüssel nicht einbegriffen	
DW 00540216	ER16	1:1	6000	30Nm	X	84.5	CHMNER16	CHUB17
DW 00540225	ER25	1:1	6000	30Nm	X	85	CHSTER25	MNLO210007

GOODWAY

MOD: GTX2000/2600 12ST. - GTZ2000/2600 12ST. - GS2000/2800 16ST. - GMT2000 - GLS2800/3300 12ST.

MODULO MOTORIZZATO RADIALE 2 USCITE IN Y
Radial single side twin head driven tool in Y
Radial angetriebenes Werkzeug 2 Ausgaenge in Y

Subject to change without notice.

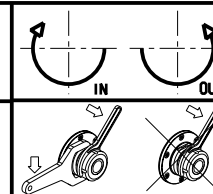

M.T. srl

Via Casino Albini 480
Tel. 0541/956034-957884
Fax 0541/956341
47842 S. GIOVANNI IN M. (RN)
e-mail: mtma@mtmarchetti.com
http://www.mtmarchetti.com

PRODUZIONE MODULI ROTANTI



PAGINA GDW080-4-00

ATTENZIONE - ATTENTION - ACHTUNG

- Per lo smontaggio degli utensili utilizzare sempre la chiave di contrasto come indicato nel manuale d'uso.
- For disassembly of the tools use always the contrast key as mentioned in the user instructions.
- Fuer das Abmontieren der Werkzeuge immer den Gegenschlüssel benutzen wie in der Bedienungsanleitung erwaeht.

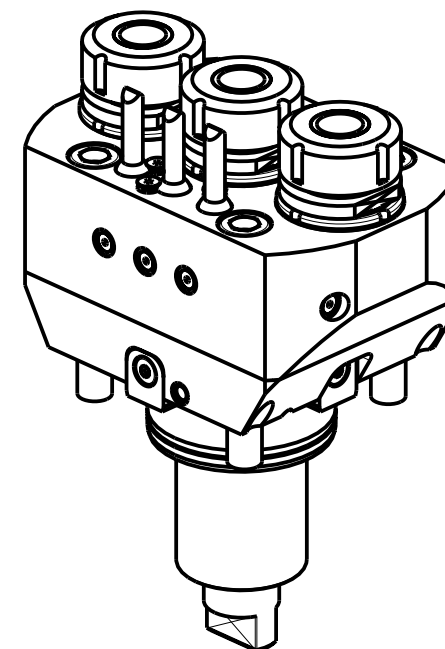
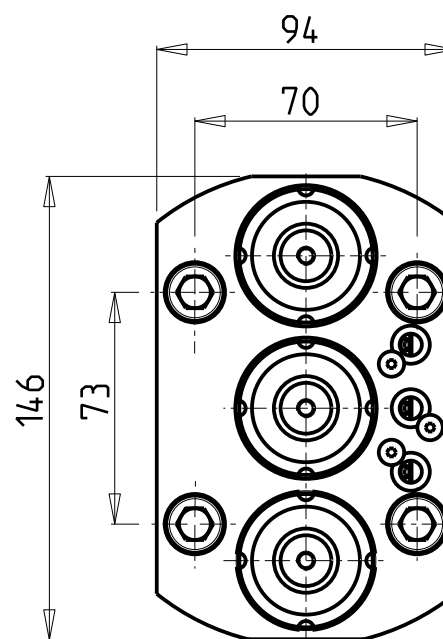
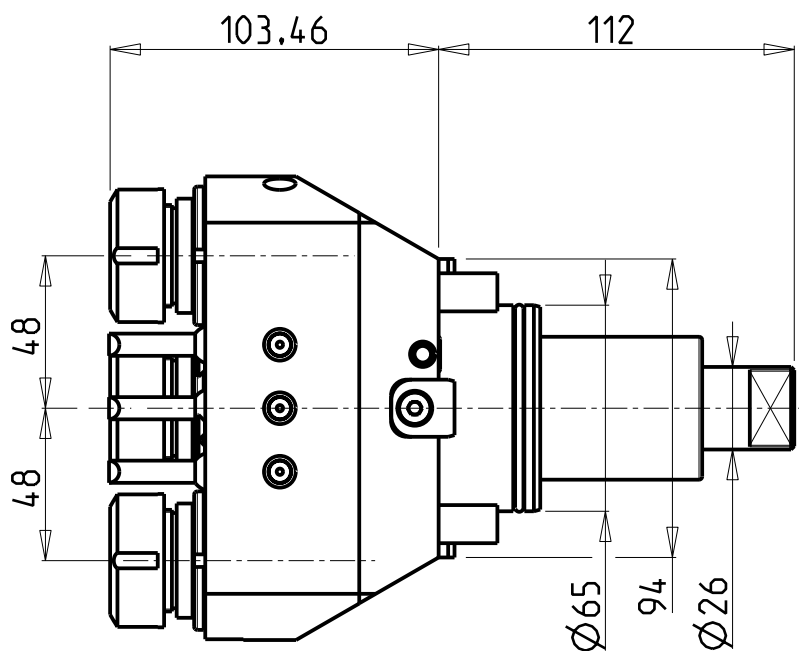

Cod. MT	Mandrino Spindle Spindel	I	RPM	Coppia Max Max Torque Max Drehmoment	Lubrificazione est. Ext. coolant Aussenkuehlung	CHIAVI INCLUSE Keys included Schluessel inbegriffen	
DW 01350325	ER25	1:1	6000	30Nm	X	MNL0210007	MNL0210008

GOODWAY

MOD: GTX2000/2600 12ST. - GTZ2000/2600 12ST. - GLS2800/3300 12ST.

MODULO MOTORIZZATO RADIALE 3 USCITE IN Y
 Radial single side 3 outlet driven tool in Y
 Radial angetriebenes Werkzeug 3 Ausgaenge in Y

Subject to change without notice.

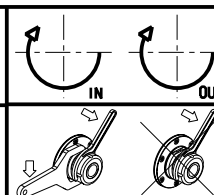

M.T. srl
 Via Casino Albini 480
 Tel. 0541/956034-957884
 Fax 0541/956341
 47842 S. GIOVANNI IN M. (RN)
 e-mail: mtma@mtmarchetti.com
 http://www.mtmarchetti.com

PRODUZIONE MODULI ROTANTI



PAGINA GDW095-4-00

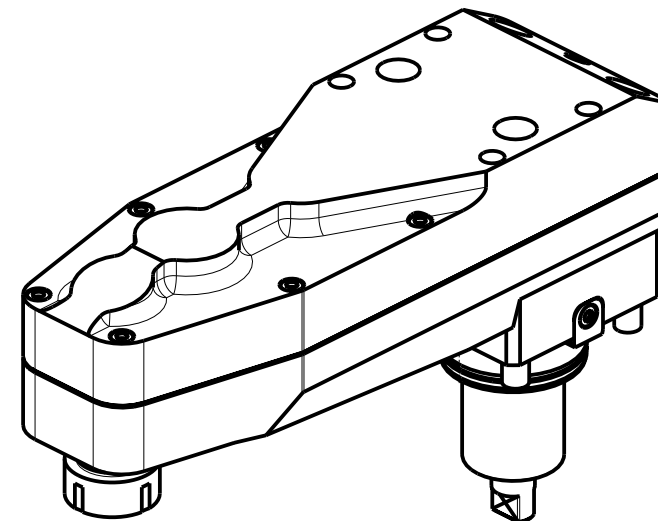
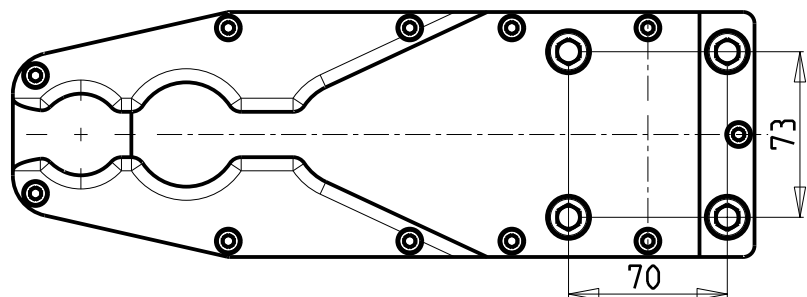
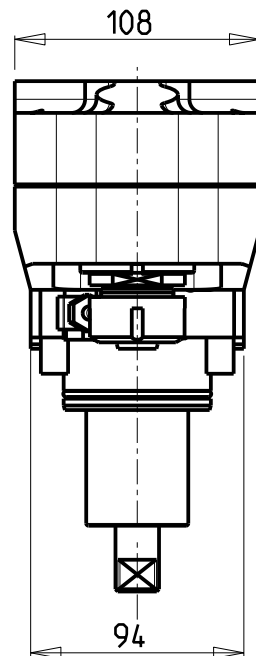
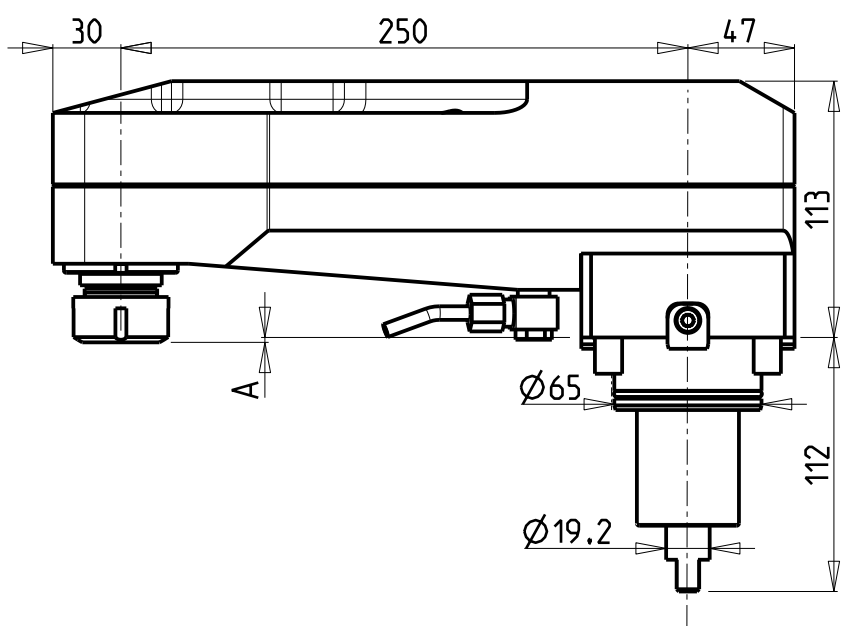

Cod. MT	Mandrino Spindle Spindel	I	RPM	Coppia Max Max Torque Max Drehmoment	Lubrificazione est. Ext. coolant Aussenkuehlung	A	CHIAVI NON INCLUSE Keys not included Schlüssel nicht einbegriffen	
0700025	ER25	1:2	12000	30Nm	X	2.16	CHSTER25	CHUB36
0700032	ER32	1:2	12000	30Nm	X	14.66	CHSTER32	CHUB36

GOODWAY

MOD: GTX2000/2600 12ST. - GTZ2000/2600 12ST. - GS2000/2800 16ST. - GMS2000 15ST. - GLS2800/3300 12ST.

MODULO MOTORIZZATO RADIALE ROVESCiato DISASSATO IN Z 250mm

Radial inverted driven tool re-directed in Z by 250mm

Radial angetriebenes Werkzeug ungekehrt achsversetzt in Z um 250mm

Subject to change without notice.

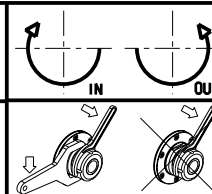

M.T. srl

Via Casino Albini 480
Tel. 0541/956034-957884
Fax 0541/956341
47842 S. GIOVANNI IN M. (RN)
e-mail: mtma@mtmarchetti.com
http://www.mtmarchetti.com

PRODUZIONE MODULI ROTANTI



PAGINA GDW 120-4-10

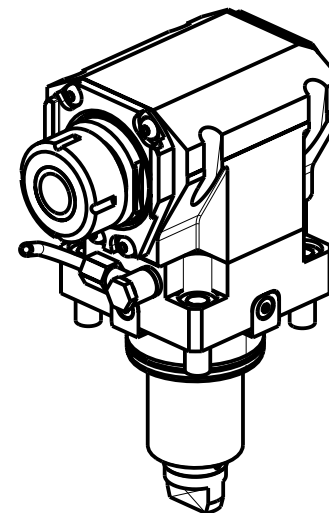
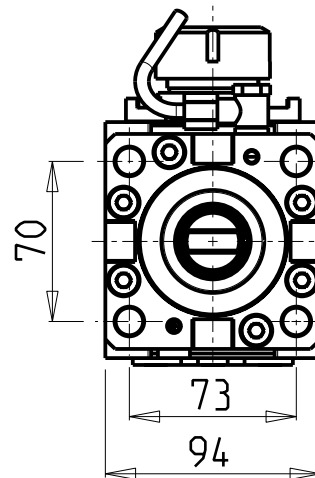
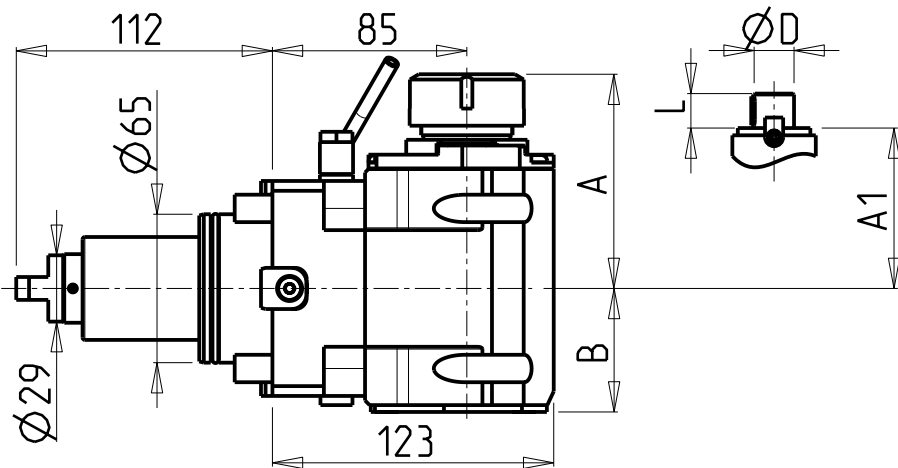

- Chiave inclusa
- Key included
- Schluessel inbegriffen

Cod. MT	Mandrino Spindle Spindel	I	RPM	Coppia Max Max Torque Max Drehmoment	Reversibile lato mandrino/contromandrino Reversible sub/main spindle side Umkehrbare Spindel-seite/ Gegenspindel-seite	Lubr.interna Coolant through Innenkuehlung	Lubr.esterna Ext. coolant Ausseinkuehlung	A	A1	B	D	L	CHIAVI NON INCLUSE Keys not included Schluessel nicht einbegriffen		
DW 01130125	ER25	1:1	6000	100Nm	X	-	X	91.16	-	54	-	-	CHSTER25	OKU0650004	
DW 01130225	ER25	1:1	6000	100Nm	X	P=70bar	X	91.16	-	65	-	-	CHSTER25	OKU0650004	
DW 01130132	ER32	1:1	6000	100Nm	X	-	X	93.66	-	54	-	-	CHSTER32	OKU0650004	
DW 01130232	ER32	1:1	6000	100Nm	X	P=70bar	X	93.66	-	65	-	-	CHSTER32	OKU0650004	
DW 01130140	ER40	1:1	6000	100Nm	X	-	X	98.16	-	54	-	-	CHSTER40	OKU0650004	
DW 01130240	ER40	1:1	6000	100Nm	X	P=70bar	X	98.16	-	65	-	-	CHSTER40	OKU0650004	
DW 01130325	ERA25	1:1	6000	100Nm	X	-	X	65	-	54	-	-	CHUB27	CHTAER25ZC	OKU0650004
DW 01130425	ERA25	1:1	6000	100Nm	X	P=70bar	X	65	-	65	-	-	CHUB27	CHTAER25ZC	OKU0650004
DW 01130516	Ø16x17	1:1	6000	100Nm	X	-	X	-	67.5	54	16	17	CH_VTCROCE_M08	OKU0650004	
DW 01130522	Ø22x19	1:1	6000	100Nm	X	-	X	-	67.5	54	22	19	CH_VTCROCE_M10	OKU0650004	
DW 01130527	Ø27x21	1:1	6000	100Nm	X	-	X	-	70	54	27	21	CH_VTCROCE_M12	OKU0650004	

GOODWAY

MOD: GTX2000/2600 12ST. - GTZ2000/2600 12ST. - GS2000/2800 16ST. - GMT2000 - GMS2000 15ST. - GLS2800/3300 12ST.

MODULO MOTORIZZATO ASSIALE H=85mm

Axial driven tool H=85mm

Axial angetriebenes Werkzeug H=85mm

Subject to change without notice.

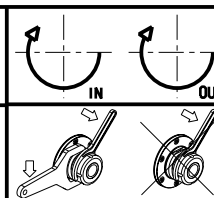

M.T. srl

Via Casino Albini 480

Tel. 0541/956034-957884

Fax 0541/956341

47842 S. GIOVANNI IN M. (RN)

e-mail: mtma@mtmarchetti.com

http://www.mtmarchetti.com

PRODUZIONE MODULI ROTANTI



PAGINA GDW 150-4-15

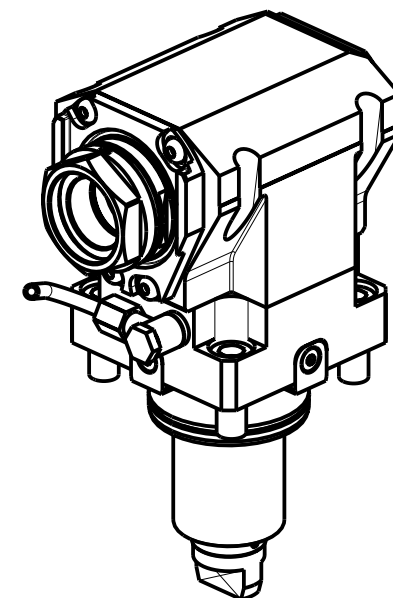
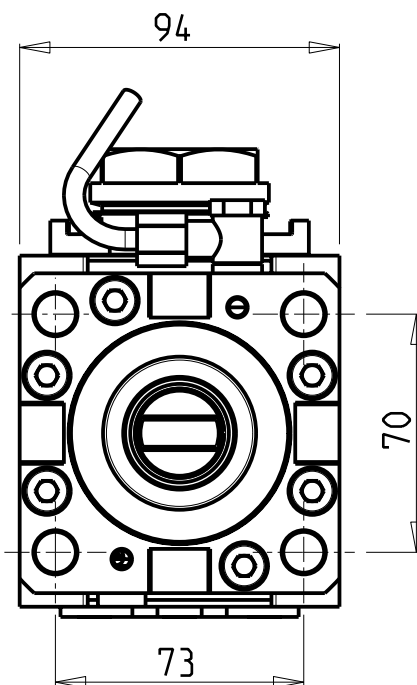
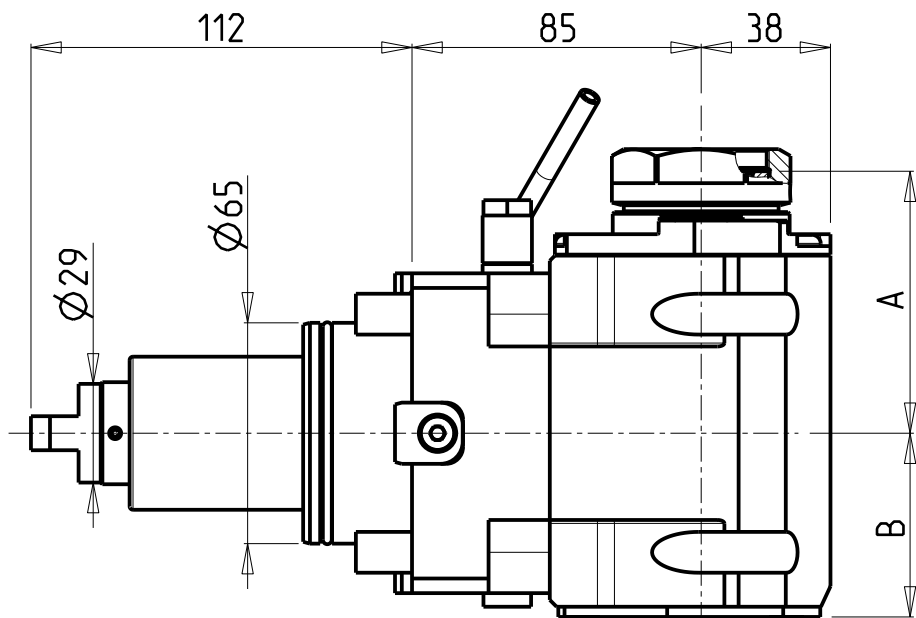

PER PORTAUTENSILI MODULARI MTSK-40 VEDI PAG. TBL300-1-40 E PER MTSK-50 VEDI PAG. TBL300-1-50
 FOR MTSK-40 QUIK CHANGE TOOLHOLDERS CLAMPINGS SEE PAGE TBL300-1-40 AND FOR MTSK-50 SEE PAGE TBL300-1-50
 FUER MTSK-40 MODULARE WERKZEUGAUFNAHMEN SIEHE SEITE TBL300-1-40 UND FUER MTSK-50 SIEHE SEITE TBL300-1-50

Cod. MT	Mandrino Spindle Spindel	I	RPM	Coppia Max Max Torque Max Drehmoment	Reversibile lato mandrino/contromandrino Reversible sub/main spindle side Umkehrbare Spindel-seite/ Gegenspindel-seite	Lubr.interna Coolant through Innenkuehlung	Lubr.esterna Ext. coolant Aussenkuehlung	A	B	CHIAVI NON INCLUSE Keys not included Schluessel nicht einbegriffen	
DW 01180140	MTSK-40	1:1	6000	100Nm	X	-	X	77	54	CHUB46	OKU0650004 •
DW 01180240	MTSK-40	1:1	6000	100Nm	X	P=70bar	X	77	65	CHUB46	OKU0650004 •
DW 01180150	MTSK-50	1:1	6000	100Nm	X	-	X	79	54	CHUB55	OKU0650004 •
DW 01180250	MTSK-50	1:1	6000	100Nm	X	P=70bar	X	79	65	CHUB55	OKU0650004 •

- Chiave inclusa
- Key included
- Schluessel inbegriffen

GOODWAY

MOD: GTX2000/2600 12ST. - GTZ2000/2600 12ST. - GS2000/2800 16ST. - GMT2000 - GMS2000 15ST. - GLS2800/3300 12ST.

MODULO MOTORIZZATO ASSIALE MTSK H=85mm

Axial MTSK driven tool H=85mm

Axial MTSK angetriebenes Werkzeug H=85mm

Subject to change without notice.

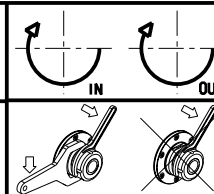

M.T. srl

Via Casino Albini 480

Tel. 0541/956034-957884

Fax 0541/956341

47842 S. GIOVANNI IN M. (RN)

e-mail: mtma@mtmarchetti.com

http://www.mtmarchetti.com

PRODUZIONE MODULI ROTANTI



PAGINA GDW 150-4-15-K

10/2018

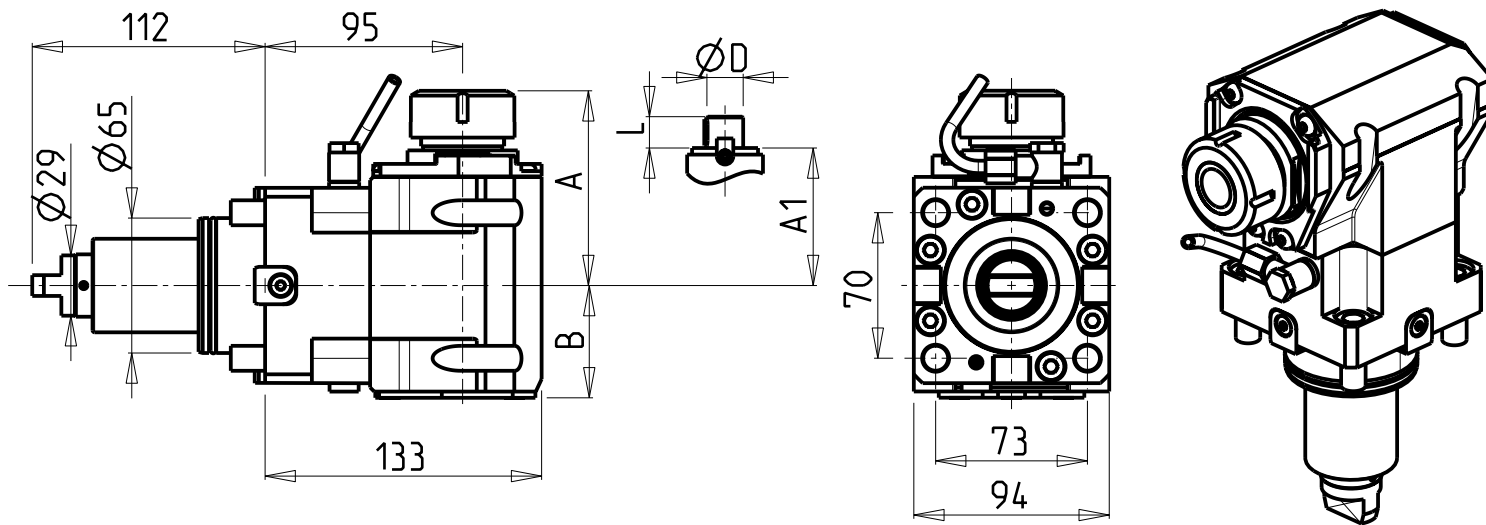

ATTENZIONE - ATTENTION - ACHTUNG

- VERIFICARE LE MISURE DI INGOMBRO PER POSSIBILE INTERFERENZA SU ALCUNI MODELLI DI MACCHINE
- Please check the overall sizes for possible interferences on some machine models
- Bitte überprüfen sie das ausmass um mögliche interferenzen auf einigen maschinen modellen zu vermeiden

• Chiave inclusa

• Key included

• Schluessel inbegriffen

Cod. MT	Mandrino Spindle Spindel	I	RPM	Coppia Max Max Torque Max Drehmoment	Reversibile lato mandrino/contromandrino Reversible sub/main spindle side Umkehrbare Spindel-seite/Gegenspindel-seite	Lubr.interna Coolant through Innenkuehlung	Lubr.esterna Ext. coolant Aussenkuehlung	A	A1	B	D	L	CHIAVI NON INCLUDE Keys not included Schluessel nicht einbegriffen		
DW 02510125	ER25	1:1	6000	100Nm	X	-	X	91.2	-	54	-	-	-	CHSTER25	OKU0650004
DW 02510225	ER25	1:1	6000	100Nm	X	P=70bar	X	91.2	-	65	-	-	-	CHSTER25	OKU0650004
DW 02510132	ER32	1:1	6000	100Nm	X	-	X	93.7	-	54	-	-	-	CHSTER32	OKU0650004
DW 02510232	ER32	1:1	6000	100Nm	X	P=70bar	X	93.7	-	65	-	-	-	CHSTER32	OKU0650004
DW 02510140	ER40	1:1	6000	100Nm	X	-	X	98.2	-	54	-	-	-	CHSTER40	OKU0650004
DW 02510240	ER40	1:1	6000	100Nm	X	P=70bar	X	98.2	-	65	-	-	-	CHSTER40	OKU0650004
DW 02510325	ERA25	1:1	6000	100Nm	X	-	X	65	-	54	-	-	CHUB27	CHTAER25ZC	OKU0650004
DW 02510425	ERA25	1:1	6000	100Nm	X	P=70bar	X	65	-	65	-	-	CHUB27	CHTAER25ZC	OKU0650004
DW 02510516	Ø16x17	1:1	6000	100Nm	X	-	X	-	67.5	54	16	17	-	CH_VTCROCE_M08	OKU0650004
DW 02510522	Ø22x19	1:1	6000	100Nm	X	-	X	-	67.5	54	22	19	-	CH_VTCROCE_M10	OKU0650004
DW 02510527	Ø27x21	1:1	6000	100Nm	X	-	X	-	70	54	27	21	-	CH_VTCROCE_M12	OKU0650004

GOODWAY

MOD: GTX2000/2600 12ST. - GTZ2000/2600 12ST. - GS2000/2800 16ST. - GMT2000 - GMS2000 15ST. - GLS2800/3300 12ST.

MODULO MOTORIZZATO ASSIALE H=95mm

Axial driven tool H=95mm

Axial angetriebenes Werkzeug H=95mm

Subject to change without notice.

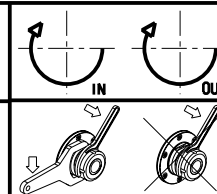

M.T. srl

Via Casino Albini 480
Tel. 0541/956034-957884

Fax 0541/956341

47842 S. GIOVANNI IN M. (RN)
e-mail: mtma@mtmarchetti.com
http://www.mtmarchetti.com

PRODUZIONE MODULI ROTANTI



PAGINA GDW 150-4-18

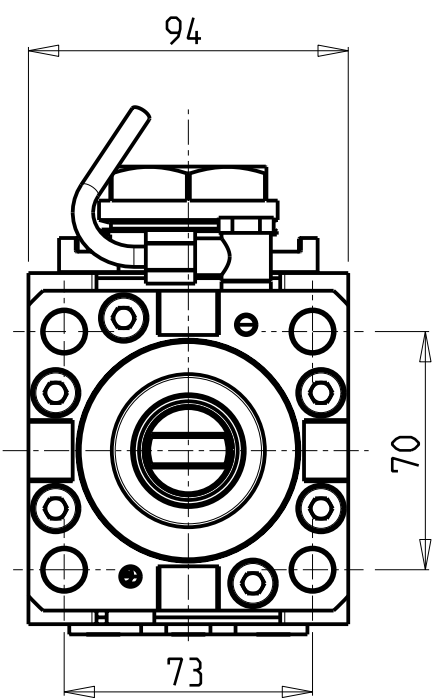
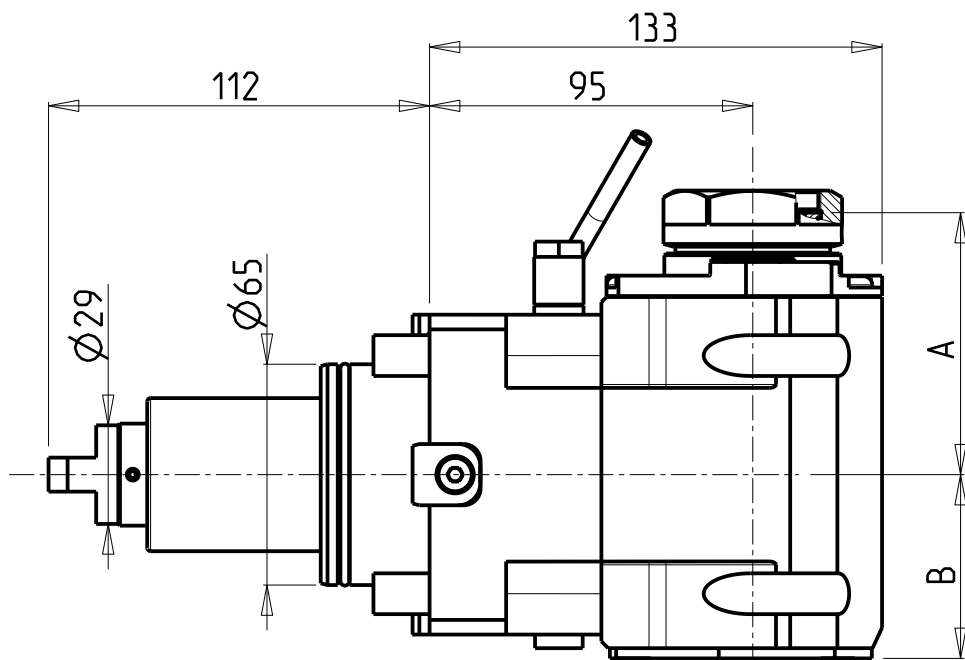

ATTENZIONE - ATTENTION - ACHTUNG

- VERIFICARE LE MISURE DI INGOMBRO PER POSSIBILE INTERFERENZA SU ALCUNI MODELLI DI MACCHINE
- Please check the overall sizes for possible interferences on some machine models
- Bitte überprüfen sie das ausmass um mögliche interferenzen auf einigen maschinen modellen zu vermeiden

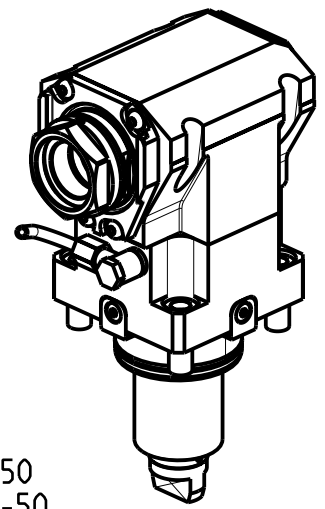

PER PORTAUTENSILI MODULARI MTSK-40 VEDI PAG. TBL300-1-40 E PER MTSK-50 VEDI PAG. TBL300-1-50
 FOR MTSK-40 QUICK CHANGE TOOLHOLDERS CLAMPINGS SEE PAGE TBL300-1-40 AND FOR MTSK-50 SEE PAGE TBL300-1-50
 FUER MTSK-40 MODULARE WERKZEUGAUFNAHMEN SIEHE SEITE TBL300-1-40 UND FUER MTSK-50 SIEHE SEITE TBL300-1-50

Cod. MT	Mandrino Spindle Spindel	I	RPM	Coppia Max Max Torque Max Drehmoment	Reversibile lato mandrino/contromandrino Reversible sub/main spindle side Umkehrbare Spindel-seite/ Gegenspindel-seite	Lubr.interna Coolant through Innenkuehlung	Lubr.esterna Ext. coolant Aussenkuehlung	A	B	CHIAVI NON INCLUSE Keys not included Schlüssel nicht einbegriffen	
DW 02530140	MTSK-40	1:1	6000	100Nm	X	-	X	77	54	CHUB46	OKU0650004 •
DW 02530240	MTSK-40	1:1	6000	100Nm	X	P=70bar	X	77	65	CHUB46	OKU0650004 •
DW 02530150	MTSK-50	1:1	6000	100Nm	X	-	X	79	54	CHUB55	OKU0650004 •
DW 02530250	MTSK-50	1:1	6000	100Nm	X	P=70bar	X	79	65	CHUB55	OKU0650004 •

- Chiave inclusa
- Key included
- Schlüssel inbegriffen

GOODWAY
 MOD: GTX2000/2600 12ST. - GTZ2000/2600 12ST. - GS2000/2800 16ST. - GMT2000 - GMS2000 15ST. - GLS2800/3300 12ST.

MODULO MOTORIZZATO ASSIALE MTSK H=95mm
 Axial MTSK driven tool H=95mm
 Axial MTSK angetriebenes Werkzeug H=95mm

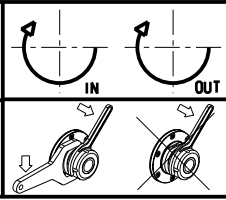

M.T. srl
 Via Casino Albini 480
 Tel. 0541/956034-957884
 Fax 0541/956341
 47842 S. GIOVANNI IN M. (RN)
 e-mail: mtma@tmarchetti.com
 http://www.tmmarchetti.com

PRODUZIONE MODULI ROTANTI

 PAGINA GDW 150-4-18-K

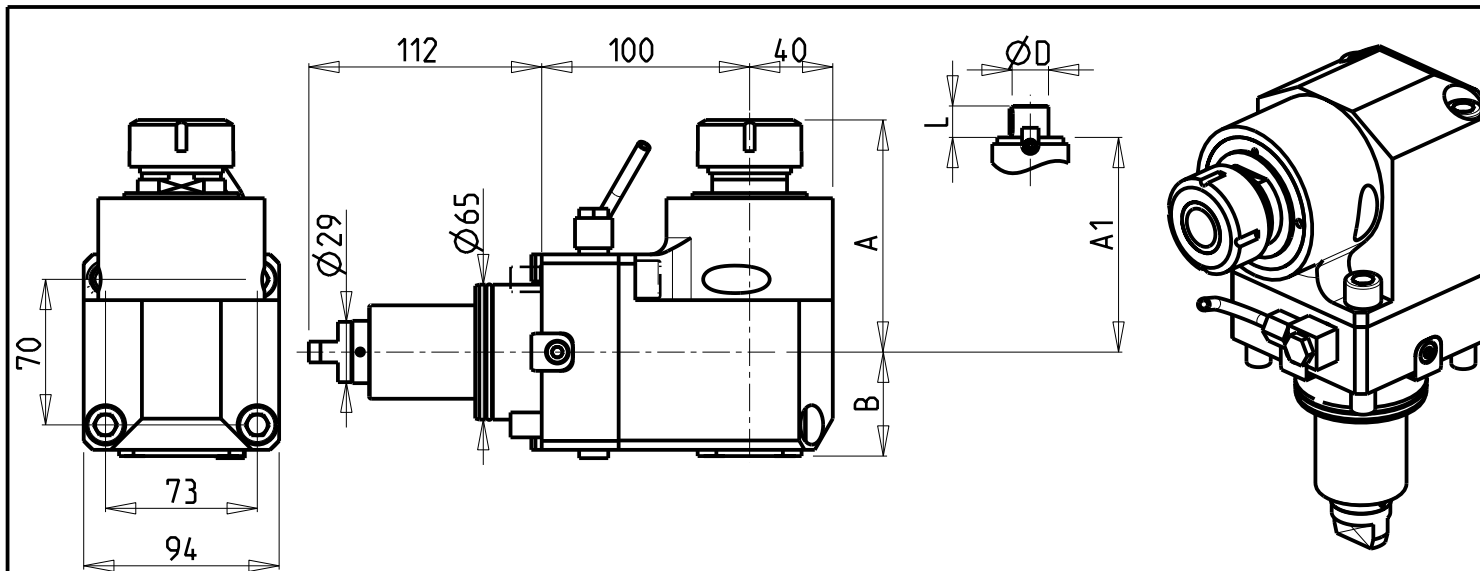
Subject to change without notice.



ATTENZIONE - ATTENTION - ACHTUNG

- VERIFICARE LE MISURE DI INGOMBRO PER POSSIBILE INTERFERENZA SU ALCUNI MODELLI DI MACCHINE
- Please check the overall sizes for possible interferences on some machine models
- Bitte überprüfen sie das ausmass um mögliche interferenzen auf einigen maschinen modellen zu vermeiden

- Chiave inclusa
- Key included
- Schlüssel inbegriffen

Cod. MT	Mandrino Spindle Spindel	I	RPM	Coppia Max Max Torque Max Drehmoment	Reversibile lato mandrino/contromandrino Reversible sub/main spindle side Umkehrbare Spindel-seite/ Gegenspindel-seite	Lubr.interna Coolant through Innenkuehlung	Lubr.esterna Ext. coolant Aussenkuehlung	A	A1	B	D	L	CHIAVI NON INCLUDE Keys not included Schluessel nicht einbegriffen	
0711432	ER32	1:1	6000	100Nm	X		X	111.56	-	47	-	-	CHSTER32	CHUB36
0711032	ER32	1:1	6000	100Nm	X	P=70bar	X	111.56	-	72	-	-	CHSTER32	CHUB36
0711532	ER A 32	1:1	6000	100Nm	X		X	102.03	-	47	-	-	CHUB50	CHUB32
0712640	ER40	1:1	6000	100Nm	X		X	115	-	47	-	-	CHSTER40	CHUB46
0712540	ER40	1:1	6000	100Nm	X	P=70bar	X	115	-	72	-	-	CHSTER40	CHUB46
0711617	Ø16x17	1:1	6000	100Nm	X		X	-	86	47	16	17	CH_VTCROCE_M08	CHUB36
0712219	Ø22x19	1:1	6000	100Nm	X		X	-	88	47	22	19	CH_VTCROCE_M10	CHUB36
0712240	Ø22x40	1:1	6000	100Nm	X		X	-	86	47	22	40	CH_VTCROCE_M10	CHUB36
0712721	Ø27x21	1:1	6000	100Nm	X		X	-	87.5	47	27	21	CH_VTCROCE_M12	CHUB36
0712733	Ø27x33	1:1	6000	100Nm	X		X	-	86	47	27	33	CH_VTCROCE_M12	CHUB36
0712750	Ø27x50	1:1	6000	100Nm	X		X	-	86	47	27	50	CH_VTCROCE_M12	CHUB36

GOODWAY

MOD: GTX2000/2600 12ST. - GTZ2000/2600 12ST. - GS2000/2800 16ST. - GMT2000 - GMS2000 15ST. - GLS2800/3300 12ST.

MODULO MOTORIZZATO ASSIALE H=100mm

Axial driven tool H=100mm

Axial angetriebenes Werkzeug H=100mm

Subject to change without notice.

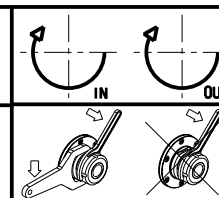

M.T. srl

Via Casino Albini 480
Tel. 0541/956034-957884
Fax 0541/956341
47842 S. GIOVANNI IN M. (RN)
e-mail: mtma@mtmarchetti.com
http://www.mtmarchetti.com

PRODUZIONE MODULI ROTANTI



PAGINA GDW 150-4-20

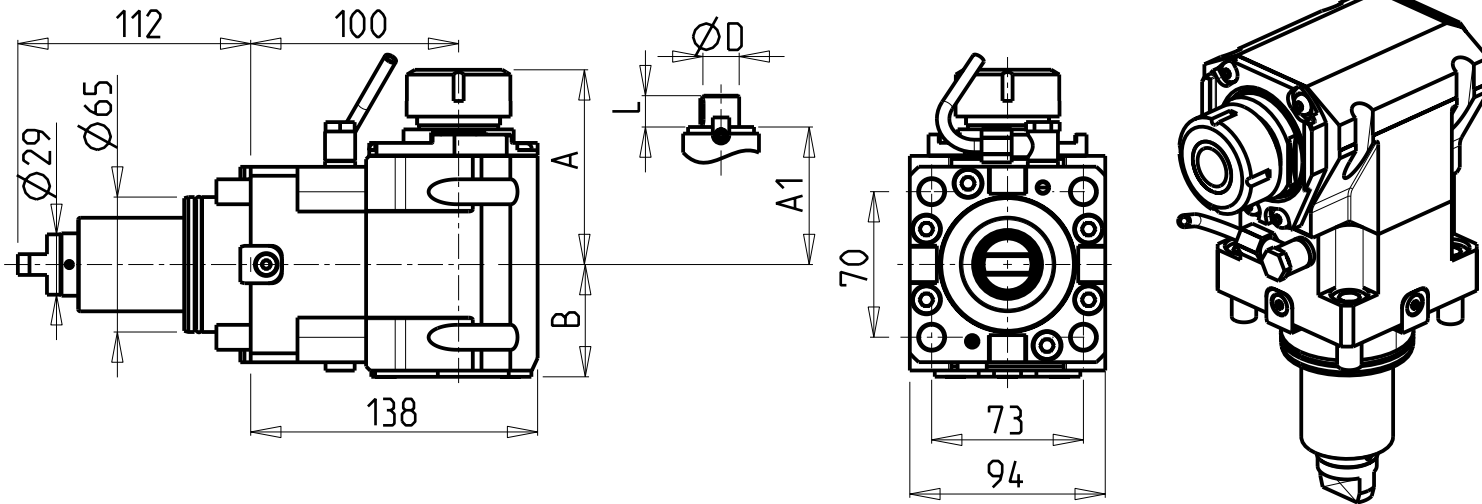

ATTENZIONE - ATTENTION - ACHTUNG

- VERIFICARE LE MISURE DI INGOMBRO PER POSSIBILE INTERFERENZA SU ALCUNI MODELLI DI MACCHINE
- Please check the overall sizes for possible interferences on some machine models
- Bitte überprüfen sie das ausmass um mögliche interferenzen auf einigen maschinen modellen zu vermeiden

- Chiave inclusa
- Key included
- Schlüssel einbegriffen

Cod. MT	Mandrino Spindel	I	RPM	Coppia Max Max Torque Max Drehmoment	Reversibile lato mandrino/contromandrino Reversible sub/main spindle side Umkehrbare Spindel-seite/Gegenspindel-seite	Lubr.interna Coolant through Innenkuehlung	Lubr.esterna Ext. coolant Aussenkuehlung	A	A1	B	D	L	CHIAVI NON INCLUSE Keys not included Schlüssel nicht einbegriffen		
DW 0114 0125	ER25	1:1	6000	100Nm	X	-	X	91.16	-	54	-	-	-	CHSTER25	OKU0650004
DW 0114 0225	ER25	1:1	6000	100Nm	X	P=70bar	X	91.16	-	65	-	-	-	CHSTER25	OKU0650004
DW 0114 0132	ER32	1:1	6000	100Nm	X	-	X	93.66	-	54	-	-	-	CHSTER32	OKU0650004
DW 0114 0232	ER32	1:1	6000	100Nm	X	P=70bar	X	93.66	-	65	-	-	-	CHSTER32	OKU0650004
DW 0114 0140	ER40	1:1	6000	100Nm	X	-	X	98.16	-	54	-	-	-	CHSTER40	OKU0650004
DW 0114 0240	ER40	1:1	6000	100Nm	X	P=70bar	X	98.16	-	65	-	-	-	CHSTER40	OKU0650004
DW 0114 0325	ERA25	1:1	6000	100Nm	X	-	X	65	-	54	-	-	CHUB27	CHTAER25ZC	OKU0650004
DW 0114 0425	ERA25	1:1	6000	100Nm	X	P=70bar	X	65	-	65	-	-	CHUB27	CHTAER25ZC	OKU0650004
DW 0114 0516	Ø16x17	1:1	6000	100Nm	X	-	X	-	67.5	54	16	17	-	CH_VTCROCE_M08	OKU0650004
DW 0114 0522	Ø22x19	1:1	6000	100Nm	X	-	X	-	67.5	54	22	19	-	CH_VTCROCE_M10	OKU0650004
DW 0114 0527	Ø27x21	1:1	6000	100Nm	X	-	X	-	70	54	27	21	-	CH_VTCROCE_M12	OKU0650004

GOODWAY

MOD: GTX2000/2600 12ST. - GTZ2000/2600 12ST. - GS2000/2800 16ST. - GMT2000 - GMS2000 15ST. - GLS2800/3300 12ST.

MODULO MOTORIZZATO ASSIALE H=100mm

Axial driven tool H=100mm

Axial angetriebenes Werkzeug H=100mm

Subject to change without notice.

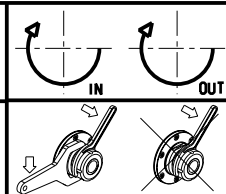

M.T. srl

Via Casino Albini 480
Tel. 0541/956034-957884

Fax 0541/956341

47842 S. GIOVANNI IN M. (RN)

e-mail: mtma@mtmarchetti.com

http://www.mtmarchetti.com

PRODUZIONE MODULI ROTANTI



PAGINA GDW 150-4-21

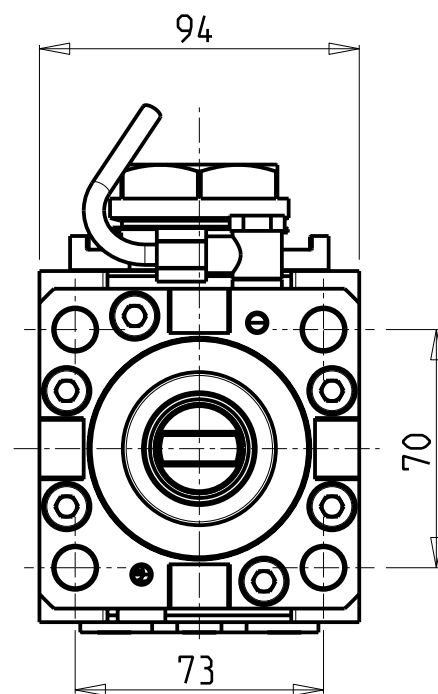
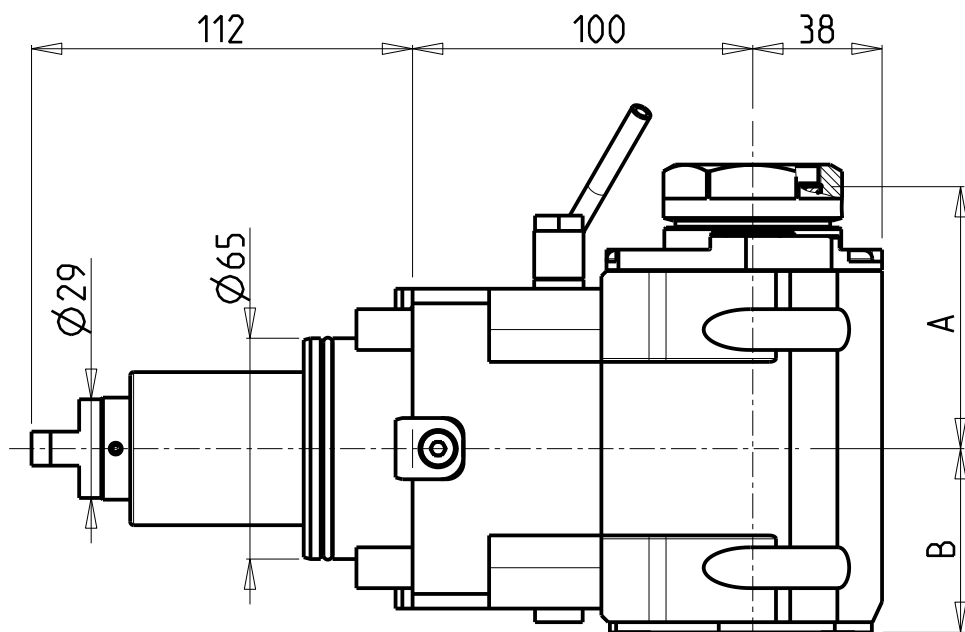

ATTENZIONE - ATTENTION - ACHTUNG

- VERIFICARE LE MISURE DI INGOMBRO PER POSSIBILE INTERFERENZA SU ALCUNI MODELLI DI MACCHINE
- Please check the overall sizes for possible interferences on some machine models
- Bitte überprüfen sie das ausmass um mögliche interferenzen auf einigen maschinen modellen zu vermeiden

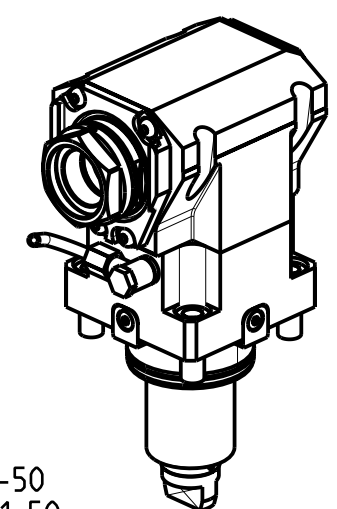

PER PORTAUTENSILI MODULARI MTSK-40 VEDI PAG. TBL300-1-40 E PER MTSK-50 VEDI PAG. TBL300-1-50
 FOR MTSK-40 QUICK CHANGE TOOLHOLDERS CLAMPINGS SEE PAGE TBL300-1-40 AND FOR MTSK-50 SEE PAGE TBL300-1-50
 FUER MTSK-40 MODULARE WERKZEUGAUFNAHMEN SIEHE SEITE TBL300-1-40 UND FUER MTSK-50 SIEHE SEITE TBL300-1-50

Cod. MT	Mandrino Spindle Spindel	I	RPM	Coppia Max Max Torque Max Drehmoment	Reversibile lato mandrino/contromandrino Reversible sub/main spindle side Umkehrbare Spindel-seite/ Gegenspindel-seite	Lubr.interna Coolant through Innenkuehlung	Lubr.esterna Ext. coolant Aussenkuehlung	A	B	CHIAVI NON INCLUSE Keys not included Schlüssel nicht einbegriffen	
DW 01190140	MTSK-40	1:1	6000	100Nm	X	-	X	77	54	CHUB46	OKU0650004 •
DW 01190240	MTSK-40	1:1	6000	100Nm	X	P=70bar	X	77	65	CHUB46	OKU0650004 •
DW 01190150	MTSK-50	1:1	6000	100Nm	X	-	X	79	54	CHUB55	OKU0650004 •
DW 01190250	MTSK-50	1:1	6000	100Nm	X	P=70bar	X	79	65	CHUB55	OKU0650004 •

- Chiave inclusa
- Key included
- Schlüssel inbegriffen

GOODWAY
 MOD: GTX2000/2600 12ST. - GTZ2000/2600 12ST. - GS2000/2800 16ST. - GMT2000 - GMS2000 15ST. - GLS2800/3300 12ST.

MODULO MOTORIZZATO ASSIALE MTSK H=100mm
 Axial MTSK driven tool H=100mm
 Axial MTSK angetriebenes Werkzeug H=100mm

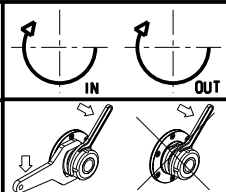

M.T. srl
 Via Casino Albini 480
 Tel. 0541/956034-957884
 Fax 0541/956341
 47842 S. GIOVANNI IN M. (RN)
 e-mail: mtma@tmarchetti.com
 http://www.tmmarchetti.com

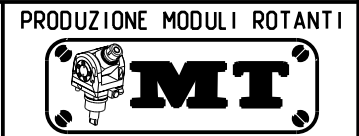

PAGINA GDW 150-4-21-K

Subject to change without notice.

10/2018

CUSCINETTI MAGGIORATI PER LAVORAZIONI PESANTI

Reinforced bearings for
heavy machining

Vergroesserte Lager fuer
schwerere Bearbeitungen

ATTENZIONE - ATTENTION - ACHTUNG

- VERIFICARE LE MISURE DI INGOMBRO PER POSSIBILE INTERFERENZA SU ALCUNI MODELLI DI MACCHINE
- Please check the overall sizes for possible interferences on some machine models
- Bitte überprüfen sie das ausmass um mögliche interferenzen auf einigen maschinen modellen zu vermeiden

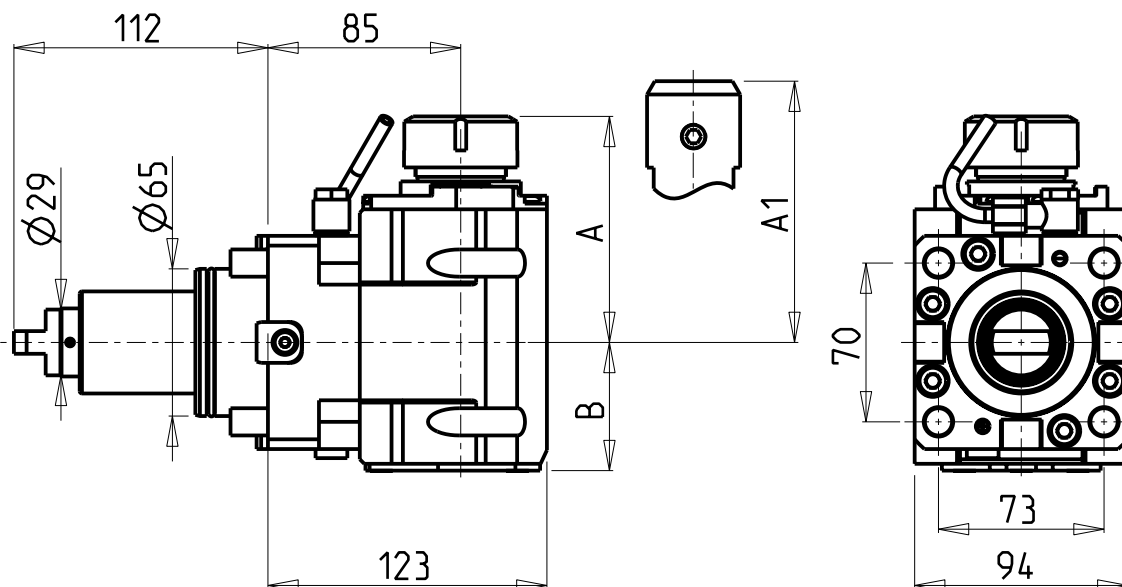

- Chiave inclusa
- Key included
- Schlüssel inbegriffen

Cod. MT	Mandrino Spindle Spindel	I	RPM	Coppia Max Max Torque Max Drehmoment	Reversibile lato mandrino/contromandrino Reversible sub/main spindle side Umkehrbare Spindel-seite/ Gegenspindel-seite	Lu-br.interna Coolant through Innenkuehlung	Lu-br.esterna Ext. coolant Aus-senkuehlung	A	A1	B	CHIAVI NON INCLUDE Keys not included Schlüssel nicht einbegriffen	
DW02480132	ER32	1:1	6000	110Nm	X	-	X	99.7	-	56.5	CHSTER32	OKU0650004
DW02480232	ER32	1:1	6000	110Nm	X	P=70bar	X	99.7	-	67.5	CHSTER32	OKU0650004
DW02480725	WELDON25	1:1	6000	110Nm	X	-	X	-	106	56.5	-	-
DW02480825	WELDON25	1:1	6000	110Nm	X	P=70bar	X	-	106	67.5	-	-

GOODWAY

MOD: GTX2000/2600 12ST. - GTZ2000/2600 12ST. - GS2000/2800 16ST. - GMT2000 - GMS2000 15ST. - GLS2800/3300 12ST.

MODULO MOTORIZZATO ASSIALE MAGGIORATO H=85mm

Axial reinforced driven tool H=85mm

Axial angetriebenes Werkzeug vergroessert H=85mm

Subject to change without notice.

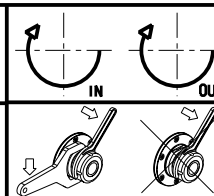

M.T. srl

Via Casino Albini 480
Tel. 0541/956034-957884
Fax 0541/956341
47842 S. GIOVANNI IN M. (RN)
e-mail: mtma@tmarchetti.com
http://www.tmmarchetti.com

PRODUZIONE MODULI ROTANTI



PAGINA GDW 170-4-20

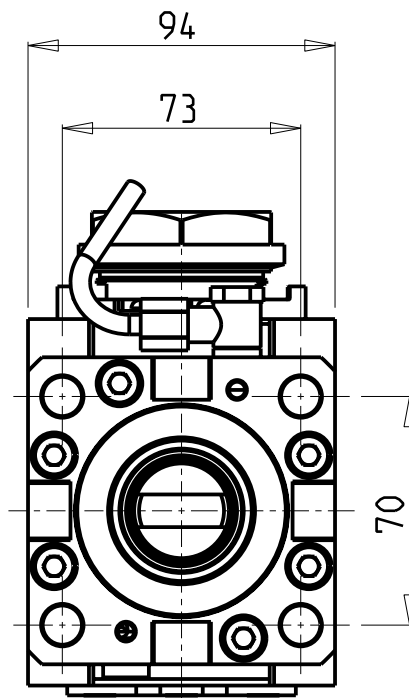
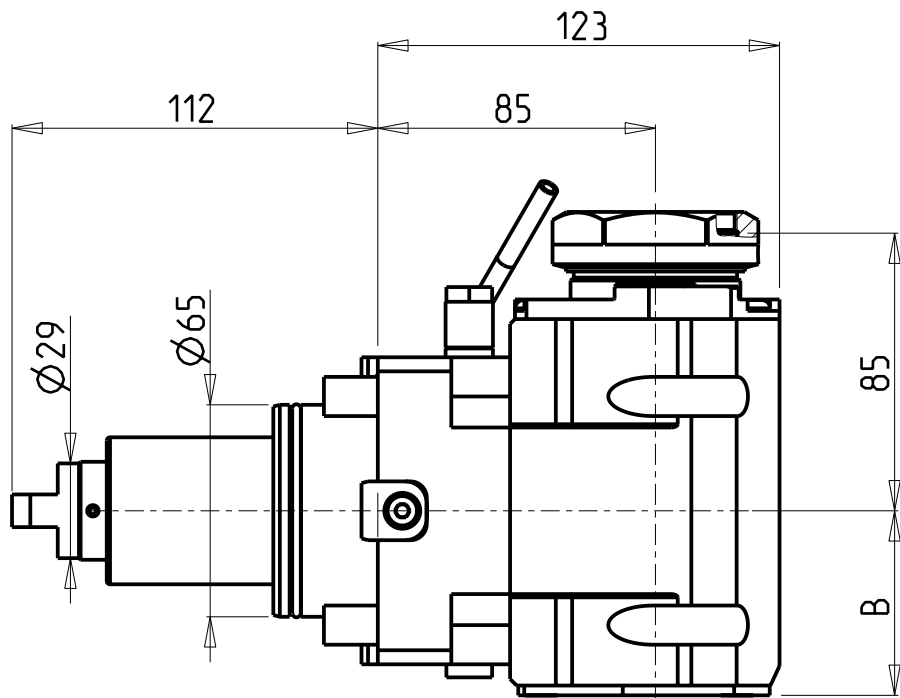

**CUSCINETTI MAGGIORATI
PER LAVORAZIONI PESANTI**

Reinforced bearings for
heavy machining

Vergroesserte Lager fuer
schwerere Bearbeitungen

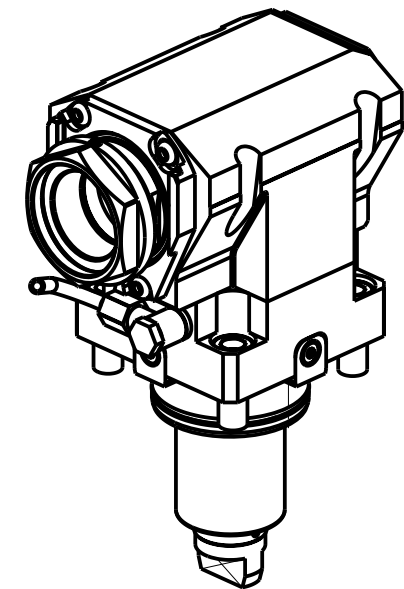

PER PORTAUTENSILI MODULARI MTSK-50 VEDI PAG. TBL300-1-50
FOR MTSK-50 QUICK CHANGE TOOLHOLDERS CLAMPINGS SEE PAGE TBL300-1-50
FUER MTSK-50 MODULARE WERKZEUGAUFNAHMEN SIEHE SEITE TBL300-1-50

Cod. MT	Mandrino Spindle Spindel	I	RPM	Coppia Max Max Torque Max Drehmoment	Reversibile lato mandrino/contromandrino Reversible sub/main spindle side Umkehrbare Spindel-seite/ Gegenspindel-seite	Lubr.interna Coolant through Innenkuehlung	Lubr.esterna Ext. coolant Aussenkuehlung	B	CHIAVI NON INCLUSE Keys not included Schluessel nicht einbegriffen	
DW 02190150	MTSK-50	1:1	6000	110Nm	X	-	X	56.5	CHUB55	OKU0650004 •
DW 02190250	MTSK-50	1:1	6000	110Nm	X	P=70bar	X	67.5	CHUB55	OKU0650004 •

- Chiave inclusa
- Key included
- Schluessel inbegriffen

GOODWAY
MOD: GTX2000/2600 12ST. - GTZ2000/2600 12ST. - GS2000/2800 16ST. - GMT2000 - GMS2000 15ST. - GLS2800/3300 12ST.

MODULO MOTORIZZATO ASSIALE MAGGIORATO MTSK H=85mm
Axial MTSK reinforced driven tool H=85mm
Axial MTSK angetriebenes Werkzeug vergroessert H=85mm

Subject to change without notice.

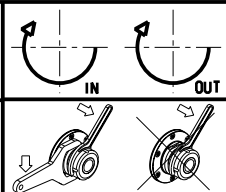

M.T. srl
Via Casino Albini 480
Tel. 0541/956034-957884
Fax 0541/956341
47842 S. GIOVANNI IN M. (RN)
e-mail: mtma@mtmarchetti.com
http://www.mtmarchetti.com

PRODUZIONE MODULI ROTANTI



PAGINA GDW 170-4-20-K

CUSCINETTI MAGGIORATI PER LAVORAZIONI PESANTI

Reinforced bearings for
heavy machining

Vergroesserte Lager fuer
schwerere Bearbeitungen

ATTENZIONE - ATTENTION - ACHTUNG

- VERIFICARE LE MISURE DI INGOMBRO PER POSSIBILE INTERFERENZA SU ALCUNI MODELLI DI MACCHINE
- Please check the overall sizes for possible interferences on some machine models
- Bitte überprüfen sie das ausmass um mögliche interferenzen auf einigen maschinen modellen zu vermeiden

- Chiave inclusa
- Key included
- Schlüssel inbegriffen

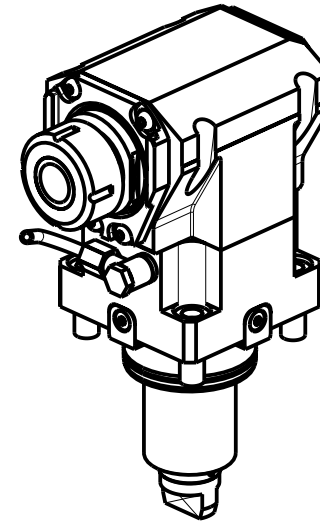
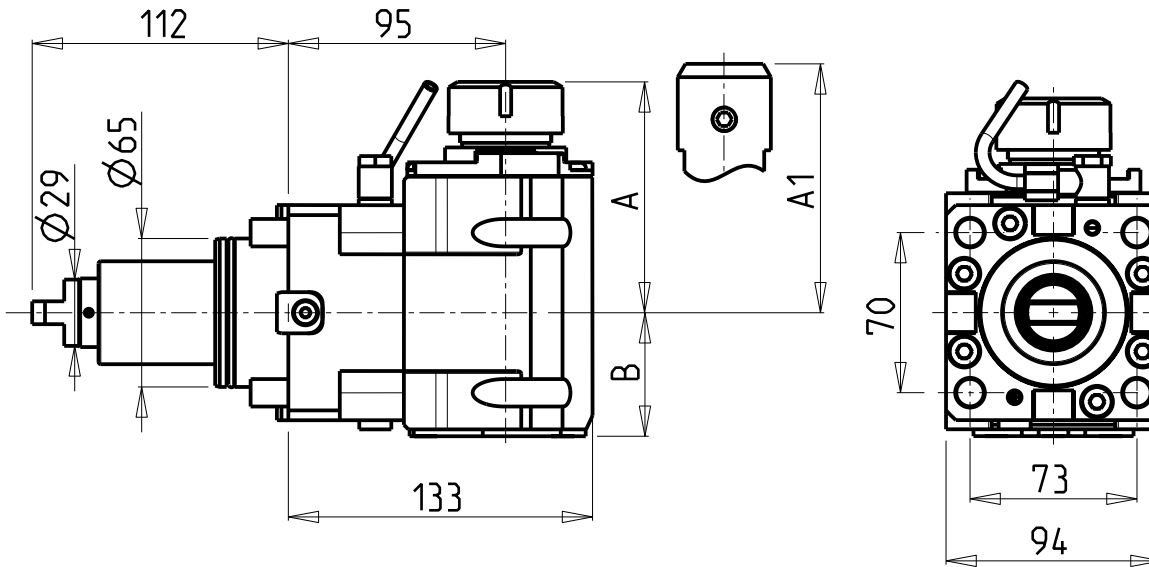

Cod. MT	Mandrino Spindle Spindel	I	RPM	Coppia Max Max Torque Max Drehmoment	Reversibile lato mandrino/contromandrino Reversible sub/main spindle side Umkehrbare Spindel-seite/ Gegenspindel-seite	Lubr.interna Coolant through Innenkuehlung	Lubr.esterna Ext. coolant Aussenkuehlung	A	A1	B	CHIAVI NON INCLUSE Keys not included Schlüssel nicht einbegriffen	
DW 02500132	ER32	1:1	6000	110Nm	X	-	X	99.7	-	56.5	CHSTER32	OKU0650004 ▪
DW 02500232	ER32	1:1	6000	110Nm	X	P=70bar	X	99.7	-	67.5	CHSTER32	OKU0650004 ▪
DW 02500725	WELDON25	1:1	6000	110Nm	X	-	X	-	106	56.5	-	-
DW 02500825	WELDON25	1:1	6000	110Nm	X	P=70bar	X	-	106	67.5	-	-

GOODWAY

MOD: GTX2000/2600 12ST. - GTZ2000/2600 12ST. - GS2000/2800 16ST. - GMT2000 - GMS2000 15ST. - GLS2800/3300 12ST.

MODULO MOTORIZZATO ASSIALE MAGGIORATO H=95mm

Axial reinforced driven tool H=95mm

Axial angetriebenes Werkzeug vergroessert H=95mm

Subject to change without notice.

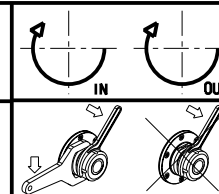

M.T. srl

Via Casino Albini 480
Tel. 0541/956034-957884
Fax 0541/956341
47842 S. GIOVANNI IN M. (RN)
e-mail: mtma@mtmarchetti.com
http://www.mtmarchetti.com

PRODUZIONE MODULI ROTANTI



PAGINA GDW 170-4-25

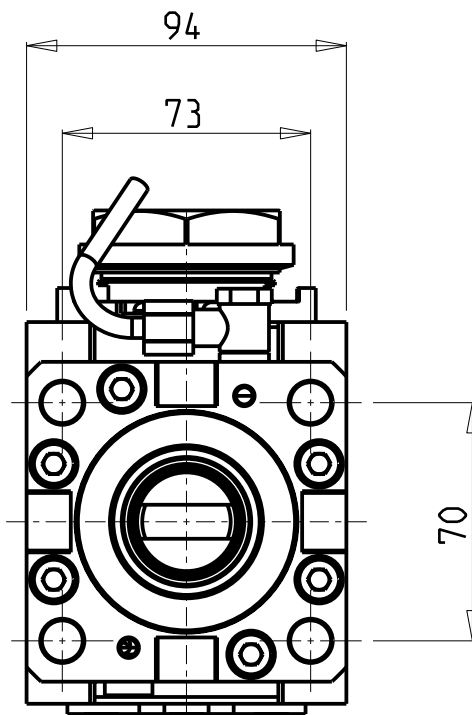
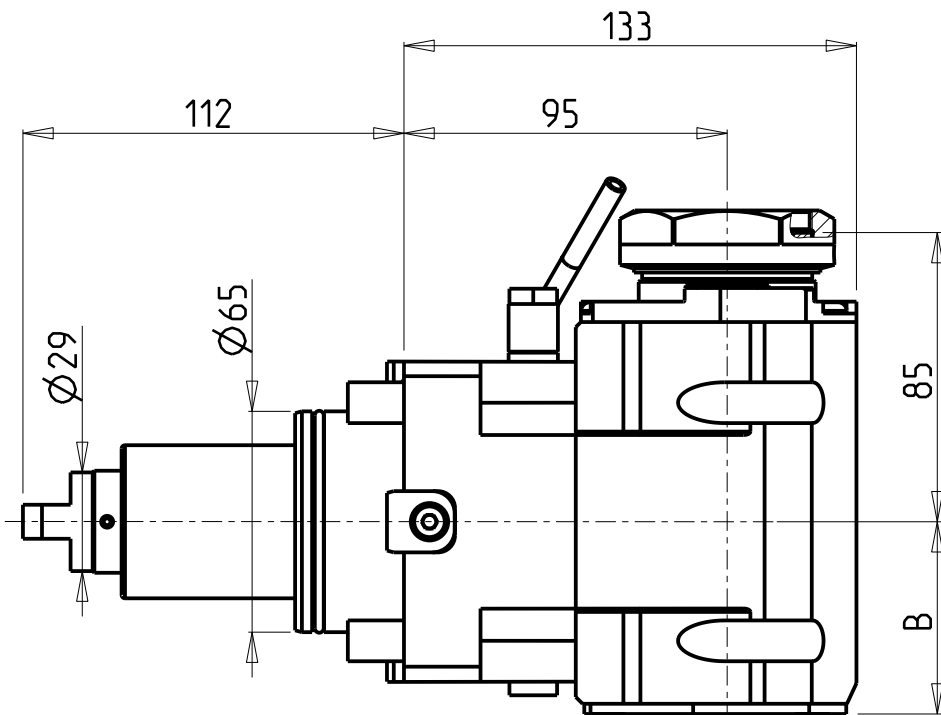

**CUSCINETTI MAGGIORATI
PER LAVORAZIONI PESANTI**

Reinforced bearings for heavy machining

Vergroesserte Lager fuer schwerere Bearbeitungen

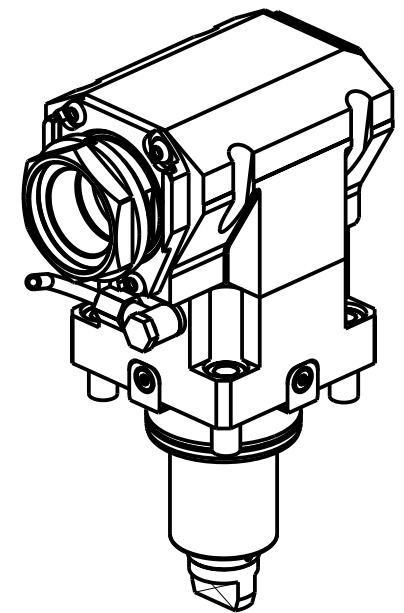

- Chiave inclusa
- Key included
- Schluessel inbegriffen

PER PORTAUTENSILI MODULARI MTSK-50 VEDI PAG. TBL300-1-50
 FOR MTSK-50 QUICK CHANGE TOOLHOLDERS CLAMPINGS SEE PAGE TBL300-1-50
 FÜR MTSK-50 MODULARE WERKZEUGAUFNAHMEN SIEHE SEITE TBL300-1-50

Cod. MT	Mandrino Spindle Spindel	I	RPM	Coppia Max Max Torque Max Drehmoment	Reversibile lato mandrino/contromandrino Reversible sub/main spindle side Umkehrbare Spindel-seite/ Gegenspindel-seite	Lubr.interna Coolant through Innenkuehlung	Lubr.esterna Ext. coolant Aussenkuehlung	B	CHIAVI NON INCLUSE Keys not included Schluessel nicht einbegriffen	
DW 0254 0150	MTSK-50	1:1	6000	110Nm	X	-	X	56.5	CHUB55	OKU0650004 •
DW 0254 0250	MTSK-50	1:1	6000	110Nm	X	P=70bar	X	67.5	CHUB55	OKU0650004 •

GOODWAY

MOD: GTX2000/2600 12ST. - GTZ2000/2600 12ST. - GS2000/2800 16ST. - GMT2000 - GMS2000 15ST. - GLS2800/3300 12ST.

MODULO MOTORIZZATO ASSIALE MAGGIORATO MTSK H=95mm
 Axial MTSK reinforced driven tool H=95mm
 Axial MTSK angetriebenes Werkzeug vergroessert H=95mm

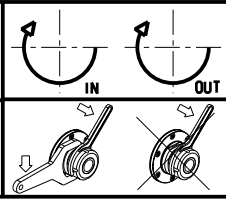

M.T. srl
 Via Casino Albini 480
 Tel. 0541/956034-957884
 Fax 0541/956341
 47842 S. GIOVANNI IN M. (RN)
 e-mail: mtma@mtmarchetti.com
 http://www.mtmarchetti.com

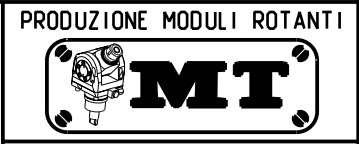

PAGINA GDW 170-4-25-K

Subject to change without notice.

CUSCINETTI MAGGIORATI PER LAVORAZIONI PESANTI

Reinforced bearings for
heavy machining

Vergroesserte Lager fuer
schwerere Bearbeitungen

ATTENZIONE - ATTENTION - ACHTUNG

- VERIFICARE LE MISURE DI INGOMBRO PER POSSIBILE INTERFERENZA SU ALCUNI MODELLI DI MACCHINE
- Please check the overall sizes for possible interferences on some machine models
- Bitte überprüfen sie das ausmass um mögliche interferenzen auf einigen maschinen modellen zu vermeiden

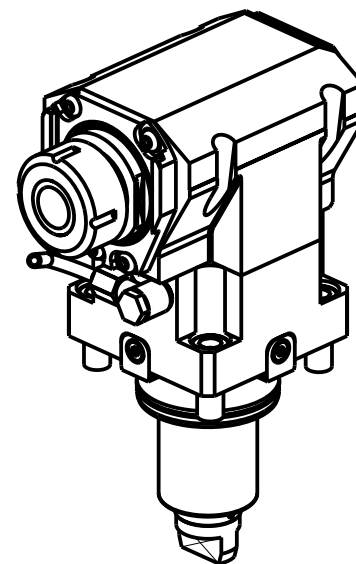
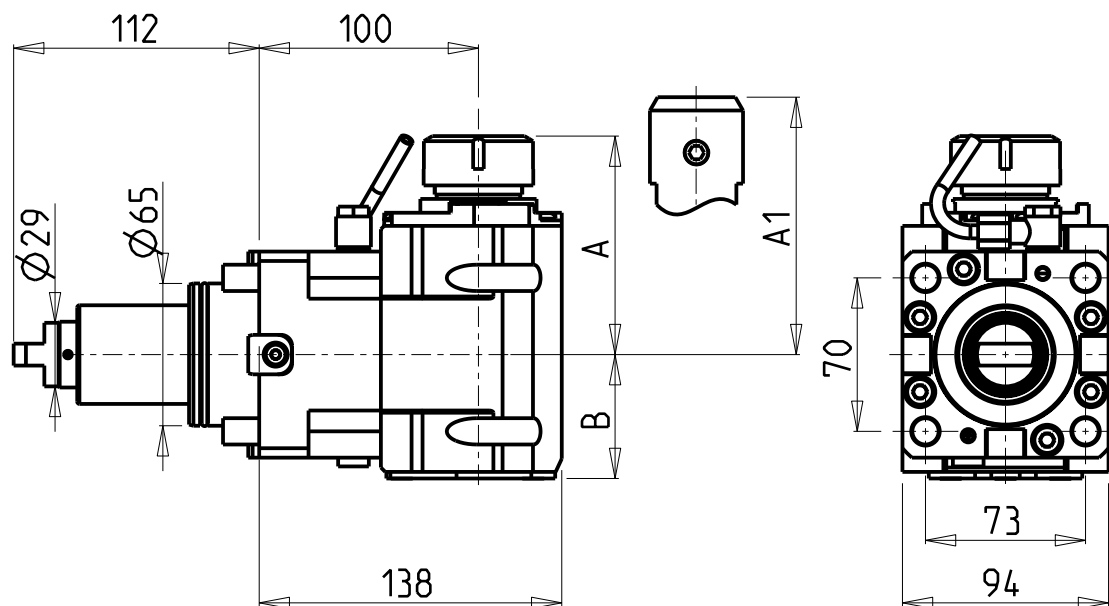

• Chiave inclusa

• Key included

• Schlüssel inbegriffen

Cod. MT	Mandrino Spindle Spindel	I	RPM	Coppia Max Max Torque Max Drehmoment	Reversibile lato mandrino/contromandrino Reversible sub/main spindle side Umkehrbare Spindel-seite/ Gegenspindel-seite	Lubr.interna Coolant through Innenkuehlung	Lubr.esterna Ext. coolant Aussenkuehlung	A	A1	B	CHIAVI NON INCLUDE Keys not included Schlüssel nicht einbegriffen	
DW 02490132	ER32	1:1	6000	110Nm	X	-	X	99.7	-	56.5	CHSTER32	OKU0650004
DW 02490232	ER32	1:1	6000	110Nm	X	P=70bar	X	99.7	-	67.5	CHSTER32	OKU0650004
DW 02490725	WELDON25	1:1	6000	110Nm	X	-	X	-	106	56.5	-	-
DW 02490825	WELDON25	1:1	6000	110Nm	X	P=70bar	X	-	106	67.5	-	-

GOODWAY

MOD: GTX2000/2600 12ST. - GTZ2000/2600 12ST. - GS2000/2800 16ST. - GMT2000 - GMS2000 15ST. - GLS2800/3300 12ST.

MODULO MOTORIZZATO ASSIALE MAGGIORATO H=100mm

Axial reinforced driven tool H=100mm

Axial angetriebenes Werkzeug vergroessert H=100mm

Subject to change without notice.

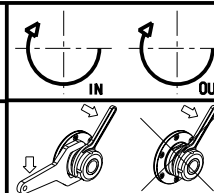

M.T. srl

Via Casino Albini 480

Tel. 0541/956034-957884

Fax 0541/956341

47842 S. GIOVANNI IN M. (RN)

e-mail: mtma@mtmarchetti.com

http://www.mtmarchetti.com

PRODUZIONE MODULI ROTANTI



PAGINA GDW 170-4-30

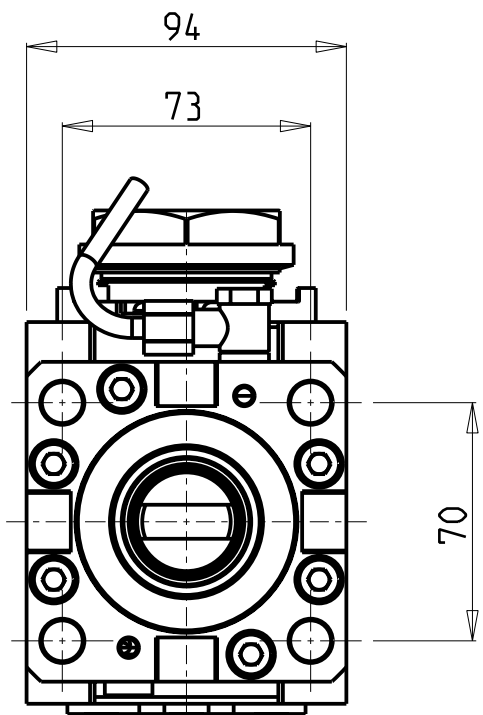
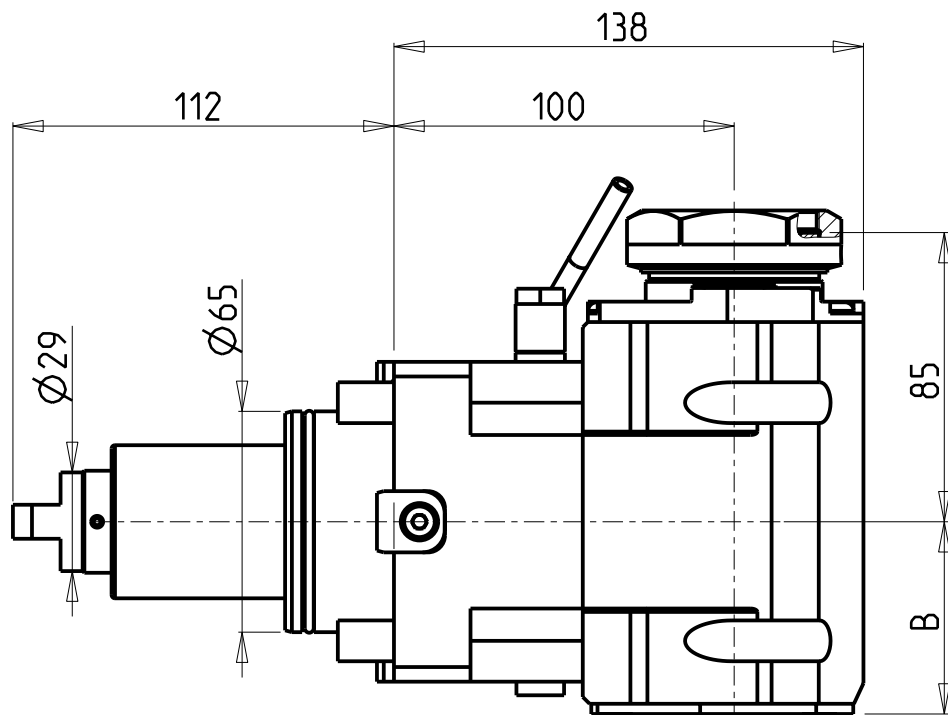

**CUSCINETTI MAGGIORATI
PER LAVORAZIONI PESANTI**

Reinforced bearings for heavy machining
Vergroesserte Lager fuer schwerere Bearbeitungen

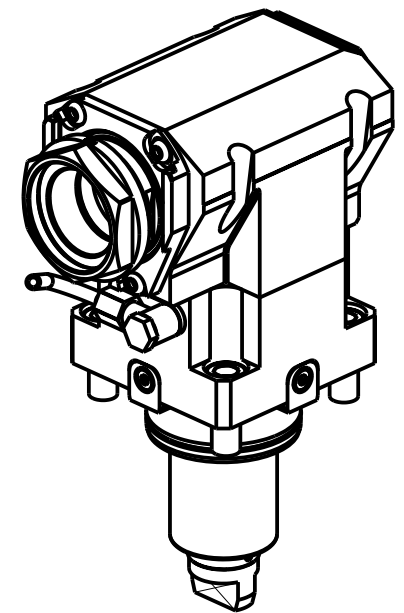

- Chiave inclusa
- Key included
- Schluessel inbegriffen

PER PORTAUTENSILI MODULARI MTSK-50 VEDI PAG. TBL300-1-50
FOR MTSK-50 QUICK CHANGE TOOLHOLDERS CLAMPINGS SEE PAGE TBL300-1-50
FUER MTSK-50 MODULARE WERKZEUGAUFNAHMEN SIEHE SEITE TBL300-1-50

Cod. MT	Mandrino Spindle Spindel	I	RPM	Coppia Max Max Torque Max Drehmoment	Reversibile lato mandrino/contromandrino Reversible sub/main spindle side Umkehrbare Spindel-seite/ Gegenspindel-seite	Lubr.interna Coolant through Innenkuehlung	Lubr.esterna Ext. coolant Aussenkuehlung	B	CHIAVI NON INCLUDE Keys not included Schluessel nicht einbegriffen
DW02200150	MTSK-50	1:1	6000	110Nm	X	-	X	56.5	CHUB55 OKU0650004 *
DW02200250	MTSK-50	1:1	6000	110Nm	X	P=70bar	X	67.5	CHUB55 OKU0650004 *

GOODWAY

MOD: GTX2000/2600 12ST. - GTZ2000/2600 12ST. - GS2000/2800 16ST. - GMT2000 - GMS2000 15ST. - GLS2800/3300 12ST.

MODULO MOTORIZZATO ASSIALE MAGGIORATO MTSK H=100mm
Axial MTSK reinforced driven tool H=100mm
Axial MTSK angetriebenes Werkzeug vergroessert H=100mm

Subject to change without notice.

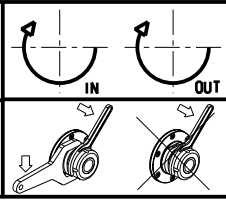

M.T. srl
Via Casino Albini 480
Tel. 0541/956034-957884
Fax 0541/956341
47842 S. GIOVANNI IN M. (RN)
e-mail: mtma@mtmarchetti.com
http://www.mtmarchetti.com

PRODUZIONE MODULI ROTANTI

PAGINA GDW 170-4-30-K

ATTENZIONE - ATTENTION - ACHTUNG

- VERIFICARE LE MISURE DI INGOMBRO PER POSSIBILE INTERFERENZA SU ALCUNI MODELLI DI MACCHINE
- Please check the overall sizes for possible interferences on some machine models
- Bitte überprüfen sie das ausmass um mögliche interferenzen auf einigen maschinen modellen zu vermeiden

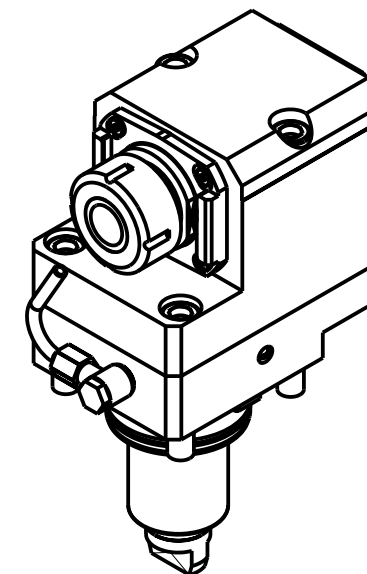
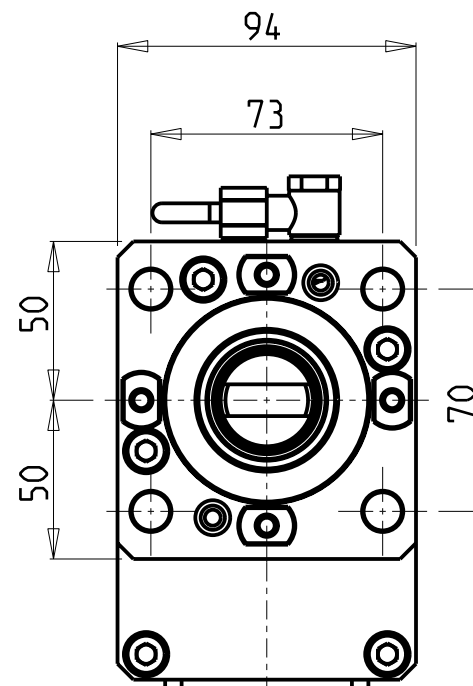
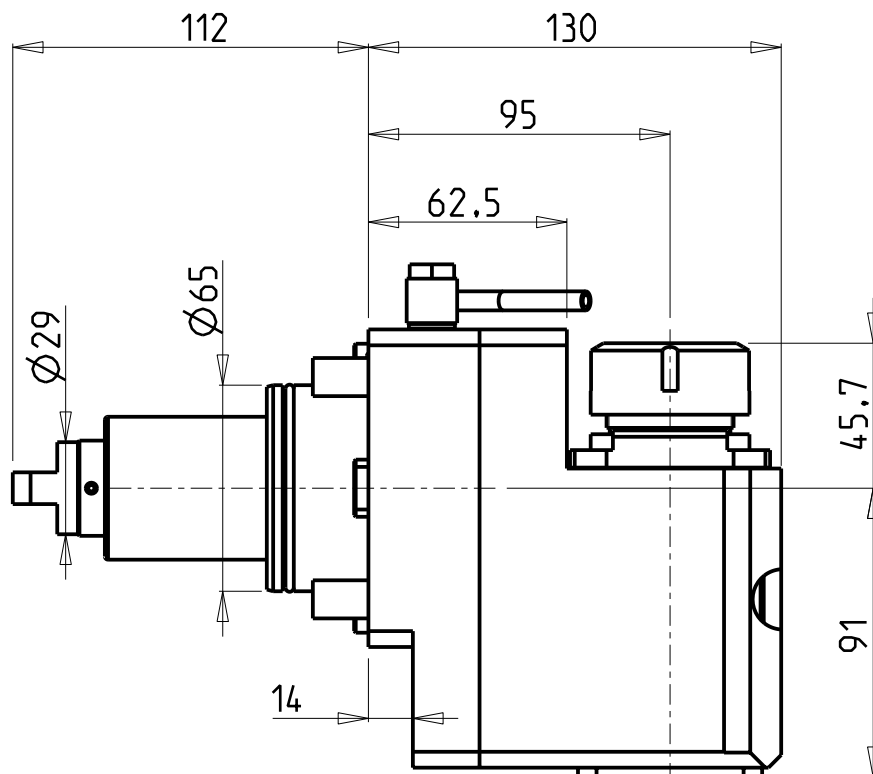

- Chiave inclusa
- Key included
- Schlüssel inbegriffen

Cod. MT	Mandrino Spindle Spindel	I	RPM	Coppia Max Max Torque Max Drehmoment	Reversibile lato mandrino/contromandrino Reversible sub/main spindle side Umkehrbare Spindel-seite/ Gegenspindel-seite	Lubrificazione est. Ext. coolant Auslenkuehlung	CHIAVI NON INCLUSE Keys not included Schluessel nicht einbegriffen
DW 02570132	ER32	1:1	6000	70Nm	X	X	CHSTER32 MNZ0410005 • NEW

GOODWAY

MOD: GTX2000/2600 12ST. - GTZ2000/2600 12ST. - GS2000/2800 16ST. - GMT2000 - GMS2000 15ST. - GLS2800/3300 12ST.

MODULO MOTORIZZATO ASSIALE ARRETRATO H=95mm
 Axial rear-set driven tool H=95mm
 Axial angetriebenes Werkzeug zurueckversetzt H=95mm

Subject to change without notice.

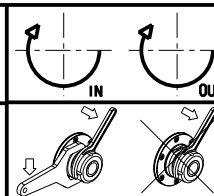

M.T. srl
 Via Casino Albini 480
 Tel. 0541/956034-957884
 Fax 0541/956341
 47842 S. GIOVANNI IN M. (RN)
 e-mail: mtma@mtmarchetti.com
 http://www.mtmarchetti.com

PRODUZIONE MODULI ROTANTI



PAGINA GDW 180-4-25

ATTENZIONE - ATTENTION - ACHTUNG

- VERIFICARE LE MISURE DI INGOMBRO PER POSSIBILE INTERFERENZA SU ALCUNI MODELLI DI MACCHINE
- Please check the overall sizes for possible interferences on some machine models
- Bitte überprüfen sie das ausmass um mögliche interferenzen auf einigen maschinen modellen zu vermeiden

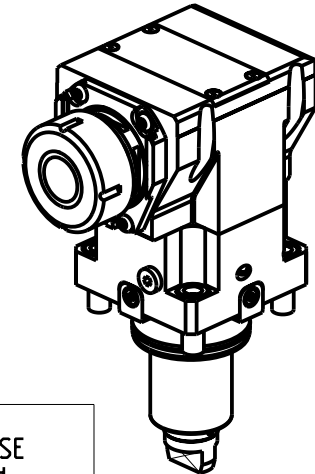
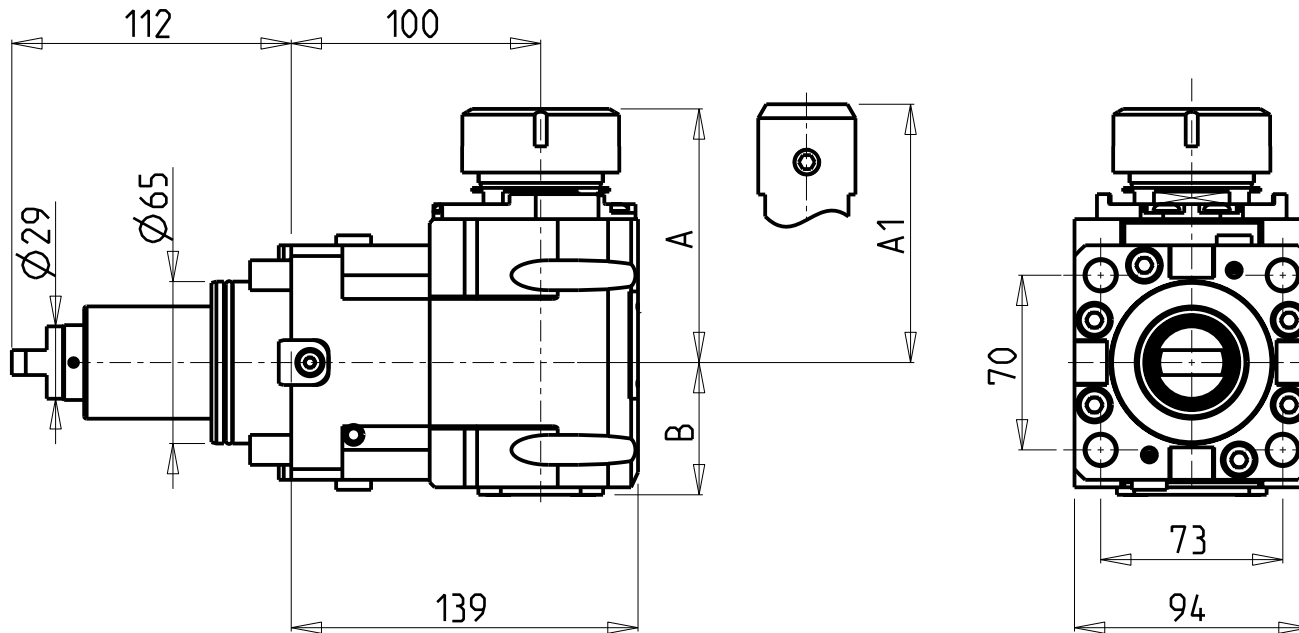

- Chiave inclusa
- Key included
- Schlüssel inbegriffen

Cod. MT	Mandrino Spindle Spindel	I	RPM	Coppia Max Max Torque Max Drehmoment	Reversibile lato mandrino/contromandrino Reversible sub/main spindle side Umkehrbare Spindel-seite/ Gegenspindel-seite	Lubr.interna Coolant through Innenkuehlung	Lubr.esterna Ext. coolant Aussenkuehlung	A	A1	B	CHIAVI NON INCLUDE Keys not included Schlüssel nicht einbegriffen	
DW 02360132	ER32	2:1	3000	130Nm	X	-	X	98.7	-	53	OKU0650004	CHSTER32
DW 02360232	ER32	2:1	3000	130Nm	X	P=70bar	X	98.7	-	66.5	OKU0650004	CHSTER32
DW 02360140	ER40	2:1	3000	130Nm	X	-	X	101.7	-	53	OKU0650004	CHSTER40
DW 02360240	ER40	2:1	3000	130Nm	X	P=70bar	X	101.7	-	66.5	OKU0650004	CHSTER40
DW 02360725	WELDON 25	2:1	3000	130Nm	X	-	X	-	106	53	-	-
DW 02360825	WELDON 25	2:1	3000	130Nm	X	P=70bar	X	-	106	66.5	-	-

GOODWAY

MOD: GTX2000/2600 12ST. - GTZ2000/2600 12ST. - GS2000/2800 16ST. - GMT2000 - GMS2000 15ST. - GLS2800/3300 12ST.

MODULO MOTORIZZATO ASSIALE RIDOTTO I=2:1 H=100mm
Axial geared-down I=2:1 driven tool H=100mm
Axial angetriebenes Werkzeug untersetzt I=2:1 H=100mm

Subject to change without notice.

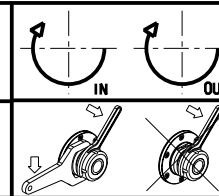

M.T. srl

Via Casino Albini 480
Tel. 0541/956034-957884
Fax 0541/956341
47842 S. GIOVANNI IN M. (RN)
e-mail: mtma@mtmarchetti.com
http://www.mtmarchetti.com

PRODUZIONE MODULI ROTANTI



PAGINA GDW 190-4-30

ATTENZIONE - ATTENTION - ACHTUNG

- VERIFICARE LE MISURE DI INGOMBRO PER POSSIBILE INTERFERENZA SU ALCUNI MODELLI DI MACCHINE
- Please check the overall sizes for possible interferences on some machine models
- Bitte überprüfen sie das ausmass um mögliche interferenzen auf einigen maschinen modellen zu vermeiden

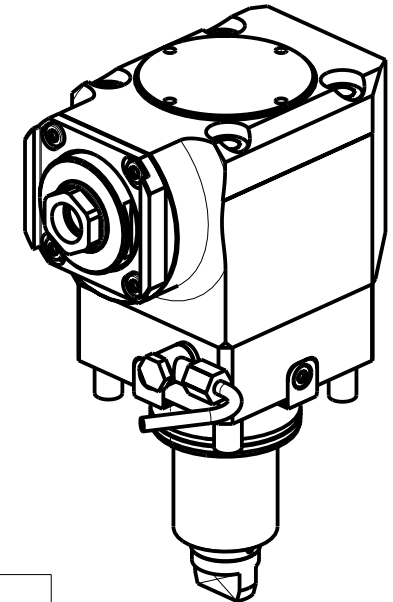
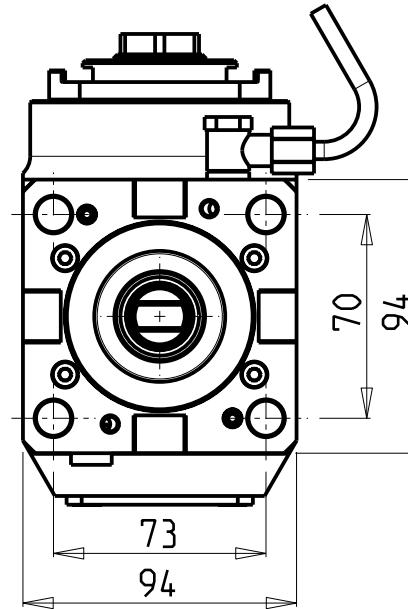
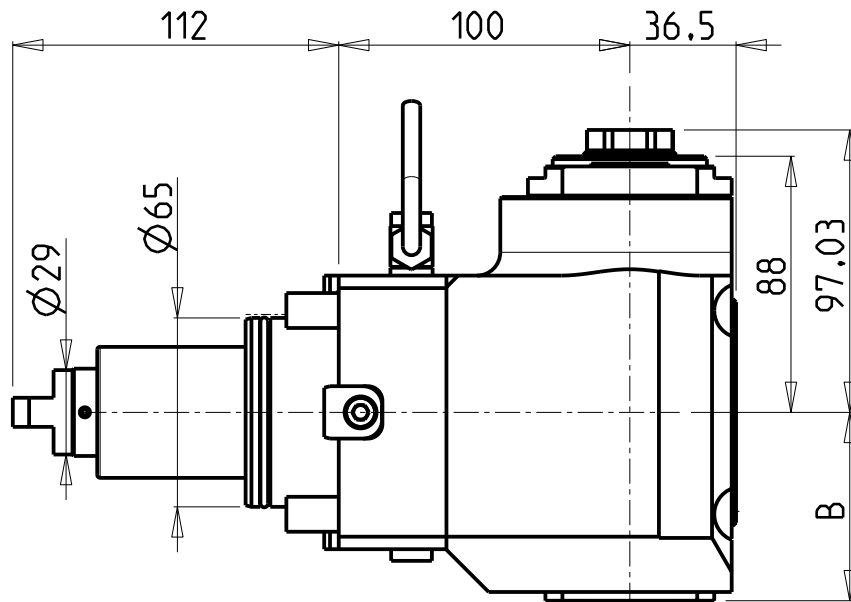

- Chiave inclusa
- Key included
- Schlüssel inbegriffen

Cod. MT	Mandrino Spindle Spindel	I	RPM	Coppia Max Max Torque Max Drehmoment	Reversibile lato mandrino/contromandrino Reversible sub/main spindle side Umkehrbare Spindelseite/ Gegenspindelseite	Lubrificazione int. Coolant through Innenkuehlung	Lubrificazione est. Ext. coolant Aussenkuehlung	B	CHIAVI NON INCLUSE Keys not included Schlüssel nicht einbegriffen	
DW 00710125	ER A 25	1:2	12000	30Nm	X		X	64.7	OKU0650004	CHUB27
DW 00710225	ER A 25	1:2	12000	30Nm	X	P=70bar	X	73.2	OKU0650004	CHUB27

GOODWAY

MOD: GTX2000/2600 12ST. - GTZ2000/2600 12ST. - GS2000/2800 16ST. - GMT2000 - GMS2000 15ST. - GLS2800/3300 12ST.

MODULO MOTORIZZATO ASSIALE MOLTIPLICATO I=1:2

Axial geared-up I=1:2 driven tool

Axial angetriebenes Werkzeug uebersetzt I=1:2

Subject to change without notice.

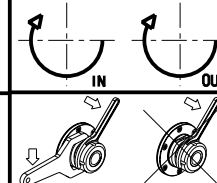

M.T. srl

Via Casino Albini 480
Tel. 0541/956034-957884
Fax 0541/956341
47842 S. GIOVANNI IN M. (RN)
e-mail: mtma@mtmarchetti.com
http://www.mtmarchetti.com

PRODUZIONE MODULI ROTANTI



PAGINA GDW 200-4-20

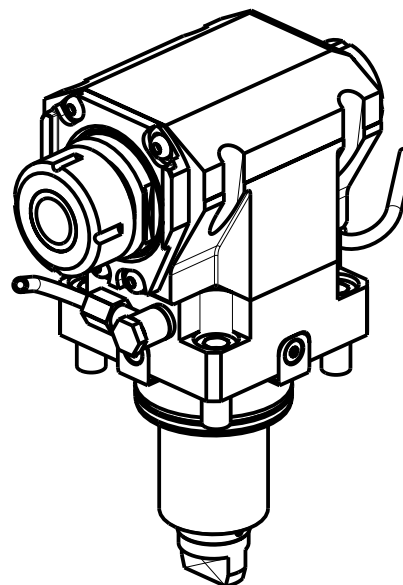
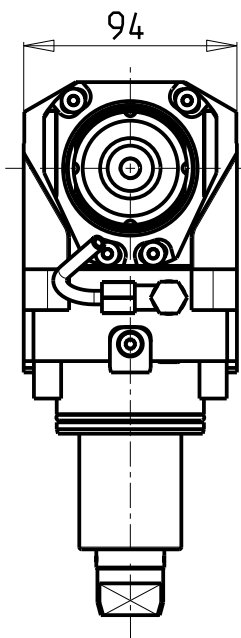
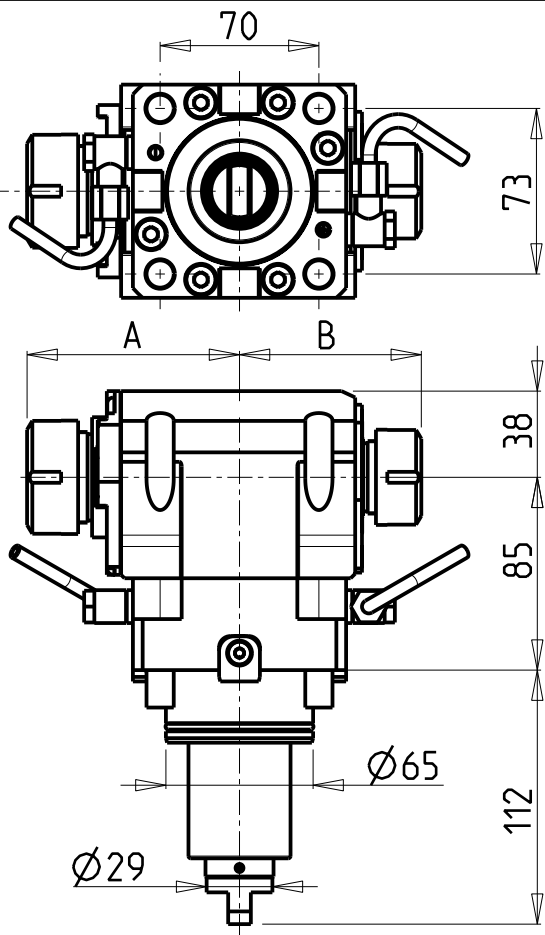

ATTENZIONE - ATTENTION - ACHTUNG

- Per lo smontaggio degli utensili utilizzare sempre la chiave di contrasto come indicato nel manuale d'uso.
- For disassembly of the tools use always the contrast key as mentioned in the user instructions.
- Fuer das Abmontieren der Werkzeuge immer den Gegenschlüssel benutzen wie in der Bedienungsanleitung erwaeht.

- Chiave inclusa
- Key included
- Schlüssel inbegriffen

Cod. MT	Mandrino Spindle Spindel	I	RPM	Coppia Max Max Torque Max Drehmoment	Reversibile lato mandrino/contromandrino Reversible sub/main spindle side Umkehrbare Spindelsete/Gegenspindelsete	Lubrificazione est. Ext. coolant Aussenkuehlung	A	B	CHIAVI NON INCLUSE Keys not included Schlüssel nicht einbegriffen					
									CHSTER32	CHSTER25	OKU0650004	-	-	
DW 01150132	ER32+ER25	1:1	6000	100Nm	X	X	93.66	80.16	CHSTER32	CHSTER25	OKU0650004	•	-	-
DW 01152520	ERA25+ERA20	1:1	6000	100Nm	X	X	65	55.5	CHUB22	CHUB27	OKU0650004	•	CHTAER20ZC	•

GOODWAY

MOD: GTX2000/2600 12ST. - GTZ2000/2600 12ST. - GS2000/2800 16ST. - GMT2000 - GMS2000 15ST. - GLS2800/3300 12ST.

MODULO MOTORIZZATO ASSIALE BISPORGENTE H=85mm

Axial opposite face driven tool H=85mm

Axial angetriebenes Werkzeug halb vorspringend H=85mm

Subject to change without notice.

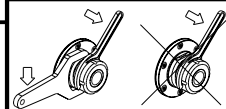

M.T. srl

Via Casino Albini 480
Tel. 0541/956034-957884
Fax 0541/956341
47842 S. GIOVANNI IN M. (RN)
e-mail: mtma@mtmarchetti.com
http://www.mtmarchetti.com

PRODUZIONE MODULI ROTANTI



PAGINA GDW 240-4-15

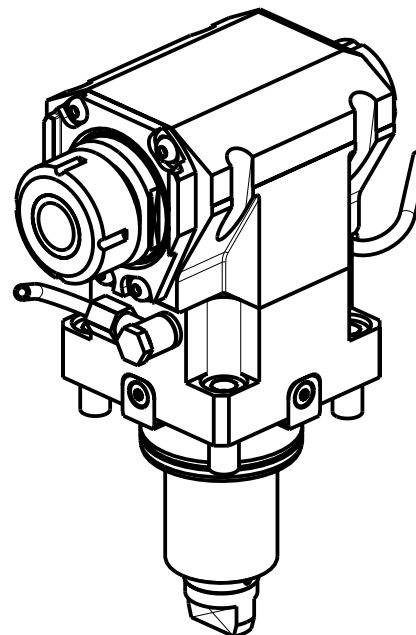
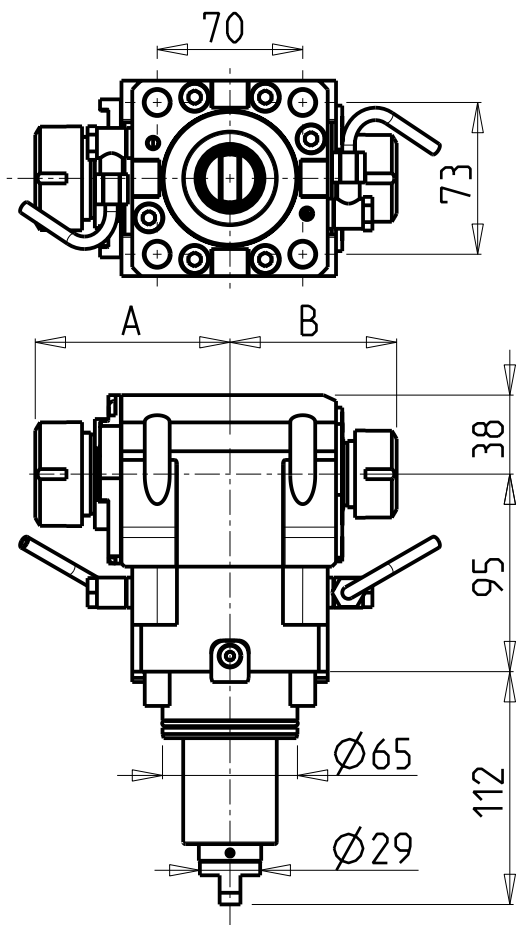

ATTENZIONE - ATTENTION - ACHTUNG

- Per lo smontaggio degli utensili utilizzare sempre la chiave di contrasto come indicato nel manuale d'uso.
- For disassembly of the tools use always the contrast key as mentioned in the user instructions.
- Fuer das Abmontieren der Werkzeuge immer den Gegenschlüssel benutzen wie in der Bedienungsanleitung erwaeht.

ATTENZIONE - ATTENTION - ACHTUNG

- VERIFICARE LE MISURE DI INGOMBRO PER POSSIBILE INTERFERENZA SU ALCUNI MODELLI DI MACCHINE
- Please check the overall sizes for possible interferences on some machine models
- Bitte ueberpruefen sie das ausmass um moegliche interferenzen auf einigen maschinen modellen zu vermeiden

- Chiave inclusa
- Key included
- Schluessel inbegriffen

Cod. MT	Mandrino Spindle Spindel	I	RPM	Coppia Max Max Torque Max Drehmoment	Reversibile lato mandrino/contromandrino Reversible sub/main spindle side Umkehrbare Spindel-seite/ Gegenspindel-seite	Lubrificazione est. Ext. coolant Aussenkuehlung	A	B	CHIAVI NON INCLUSE Keys not included Schluessel nicht einbegriffen				
DW 02520132	ER32+ER25	1:1	6000	100Nm	X	X	93.7	80.2	CHSTER32	CHSTER25	OKU0650004	-	-
DW 02522520	ERA25+ERA20	1:1	6000	100Nm	X	X	65	55.5	CHUB22	CHUB27	OKU0650004	CHTAER20ZC	CHTAER25ZC

GOODWAY
 MOD: GTX2000/2600 12ST. - GTZ2000/2600 12ST. - GS2000/2800 16ST. - GMT2000 - GMS2000 15ST. - GLS2800/3300 12ST.

MODULO MOTORIZZATO ASSIALE BISPORGENTE H=95mm
 Axial opposite face driven tool H=95mm
 Axial angetriebenes Werkzeug halb vorspringend H=95mm

Subject to change without notice.

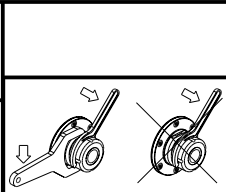

M.T. srl
 Via Casino Albini 480
 Tel. 0541/956034-957884
 Fax 0541/956341
 47842 S. GIOVANNI IN M. (RN)
 e-mail: mtma@mtmarchetti.com
 http://www.mtmarchetti.com

PRODUZIONE MODULI ROTANTI



PAGINA GDW 240-4-18

ATTENZIONE - ATTENTION - ACHTUNG

- Per lo smontaggio degli utensili utilizzare sempre la chiave di contrasto come indicato nel manuale d'uso.
- For disassembly of the tools use always the contrast key as mentioned in the user instructions.
- Fuer das Abmontieren der Werkzeuge immer den Gegenschlüssel benutzen wie in der Bedienungsanleitung erwaeht.

ATTENZIONE - ATTENTION - ACHTUNG

- VERIFICARE LE MISURE DI INGOMBRO PER POSSIBILE INTERFERENZA SU ALCUNI MODELLI DI MACCHINE
- Please check the overall sizes for possible interferences on some machine models
- Bitte überprüfen sie das ausmass um mögliche interferenzen auf einigen maschinen modellen zu vermeiden

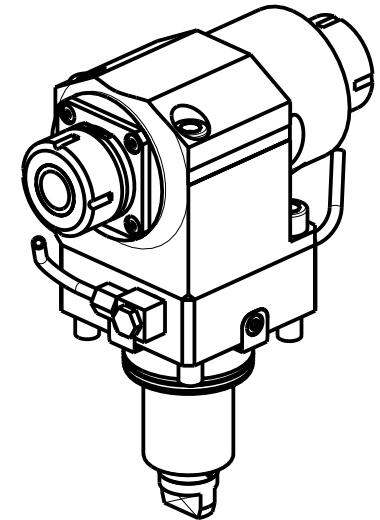
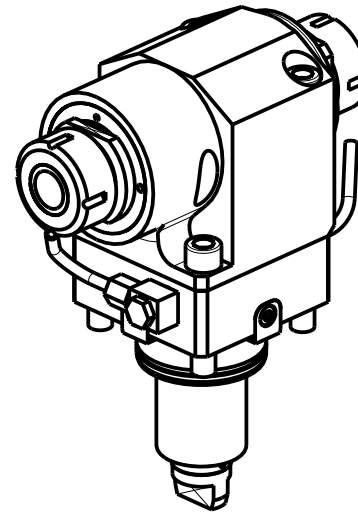
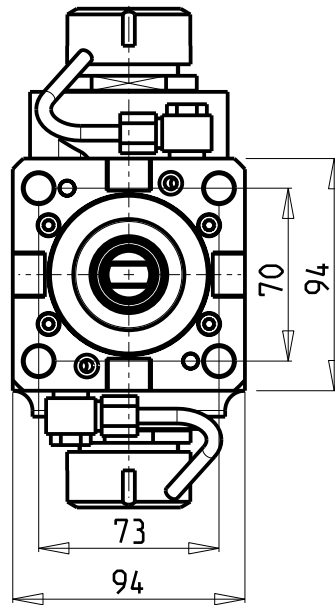
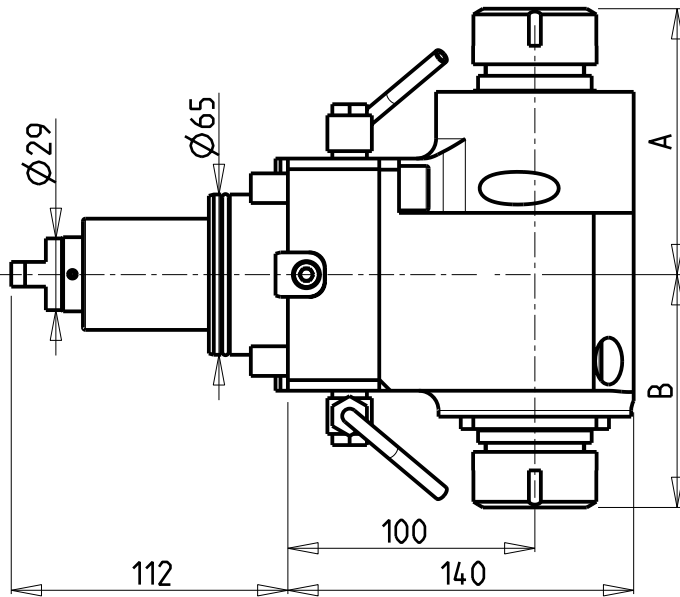

Cod. MT	Mandrino Spindle Spindel	I	RPM	Coppia Max Max Torque Max Drehmoment	Reversibile lato mandrino/contromandrino Reversible sub/main spindle side Umkehrbare Spindel-seite/Gegenspindel-seite	Lubrificazione est. Ext. coolant Aussenkuehlung	A	B	CHIAVI NON INCLUSE Keys not included Schluessel nicht einbegriffen		
									CHSTER32	CHUB46	
DW 00070232	ER32+ER32	1:1	6000	100Nm	X	X	107.66	94.26	CHSTER32	CHUB46	
DW 00073225	ERA25+ERA32	1:1	6000	100Nm	X	X	106.03	81.13	CHUB27	CHUB32	CHUB46

GOODWAY

MOD: GTX2000/2600 12ST. - GTZ2000/2600 12ST. - GS2000/2800 16ST. - GMT2000 - GMS2000 15ST. - GLS2800/3300 12ST.

MODULO MOTORIZZATO ASSIALE BISPORGENTE H=100mm

Axial opposite face twin driven tool H=100mm

Axial angetriebenes Werkzeug halb vorspringend H=100mm

Subject to change without notice.

M.T. srl

Via Casino Albini 480
Tel. 0541/956034-957884
Fax 0541/956341
47842 S. GIOVANNI IN M. (RN)
e-mail: mtma@tmarchetti.com
http://www.tmmarchetti.com

PRODUZIONE MODULI ROTANTI



PAGINA GDW 240-4-20

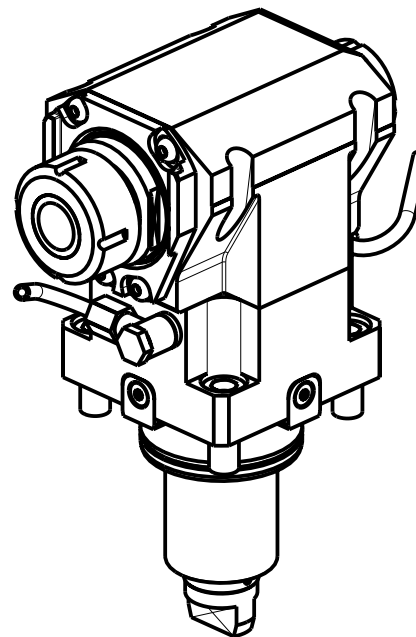
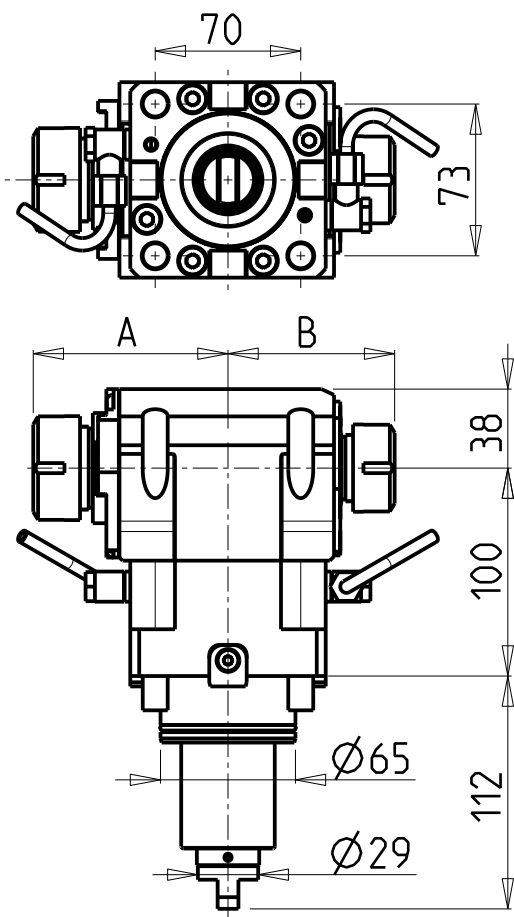

ATTENZIONE - ATTENTION - ACHTUNG

- Per lo smontaggio degli utensili utilizzare sempre la chiave di contrasto come indicato nel manuale d'uso.
- For disassembly of the tools use always the contrast key as mentioned in the user instructions.
- Fuer das Abmontieren der Werkzeuge immer den Gegenschlüssel benutzen wie in der Bedienungsanleitung erwaeht.

ATTENZIONE - ATTENTION - ACHTUNG

- VERIFICARE LE MISURE DI INGOMBRO PER POSSIBILE INTERFERENZA SU ALCUNI MODELLI DI MACCHINE
- Please check the overall sizes for possible interferences on some machine models
- Bitte ueberpruefen sie das ausmass um moegliche interferenzen auf einigen maschinen modellen zu vermeiden

• Chiave inclusa

• Key included

• Schlüssel inbegriffen

Cod. MT	Mandrino Spindle Spindel	I	RPM	Coppia Max Max Torque Max Drehmoment	Reversibile lato mandrino/contromandrino Reversible sub/main spindle side Umkehrbare Spindelsete/Gegenspindelsete	Lubrificazione est. Ext. coolant Aussenkuehlung	A	B	CHIAVI NON INCLUSE Keys not included Schlüssel nicht einbegriffen				
DW 01160132	ER32+ER25	1:1	6000	100Nm	X	X	93.66	80.16	CHSTER32	CHSTER25	OKU0650004	-	-
DW 01162520	ERA25+ERA20	1:1	6000	100Nm	X	X	65	55.5	CHUB22	CHUB27	OKU0650004	CHTAER20ZC	CHTAER25ZC

GOODWAY

MOD: GTX2000/2600 12ST. - GTZ2000/2600 12ST. - GS2000/2800 16ST. - GMT2000 - GMS2000 15ST. - GLS2800/3300 12ST.

MODULO MOTORIZZATO ASSIALE BISPORGENTE H=100mm

Axial opposite face driven tool H=100mm

Axial angetriebenes Werkzeug halb vorspringend H=100mm

Subject to change without notice.

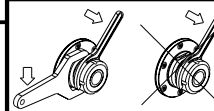

M.T. srl

Via Casino Albini 480
Tel. 0541/956034-957884
Fax 0541/956341
47842 S. GIOVANNI IN M. (RN)
e-mail: mtma@mtmarchetti.com
http://www.mtmarchetti.com

PRODUZIONE MODULI ROTANTI



PAGINA GDW 240-4-21

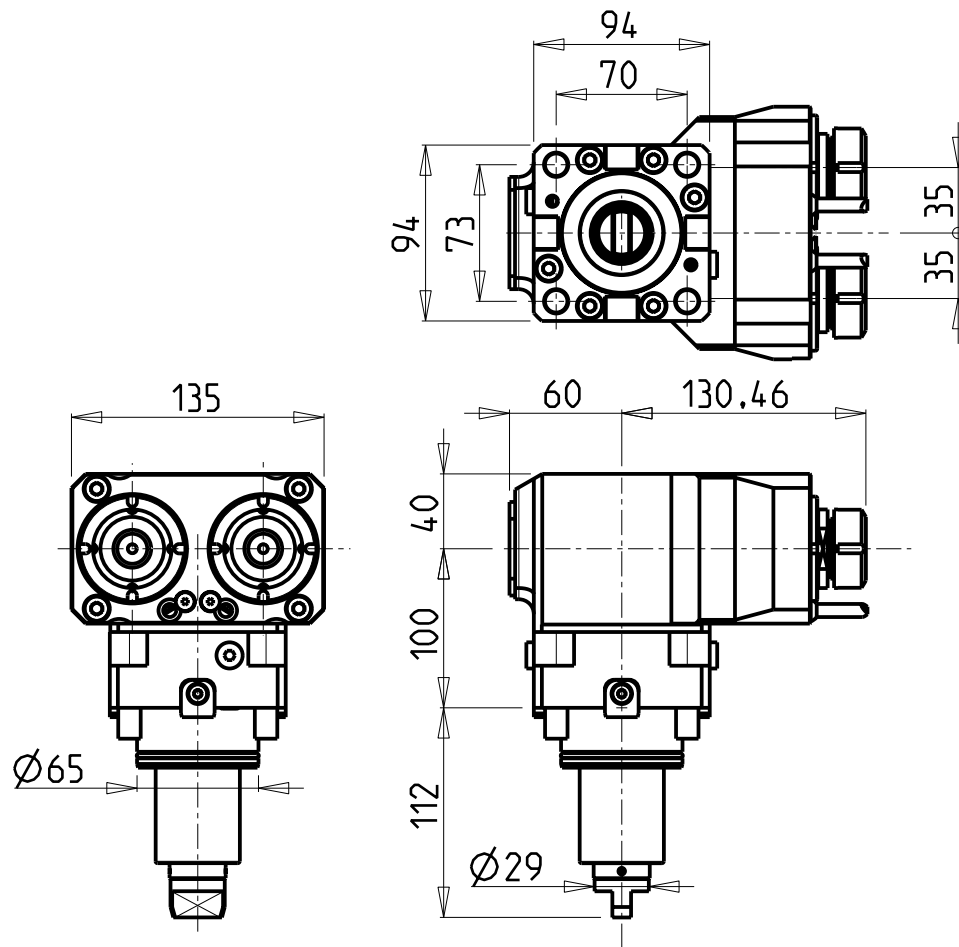

ATTENZIONE - ATTENTION - ACHTUNG

- Per lo smontaggio degli utensili utilizzare sempre la chiave di contrasto come indicato nel manuale d'uso.
- For disassembly of the tools use always the contrast key as mentioned in the user instructions.
- Fuer das Abmontieren der Werkzeuge immer den Gegenschlüssel benutzen wie in der Bedienungsanleitung erwäehnt.

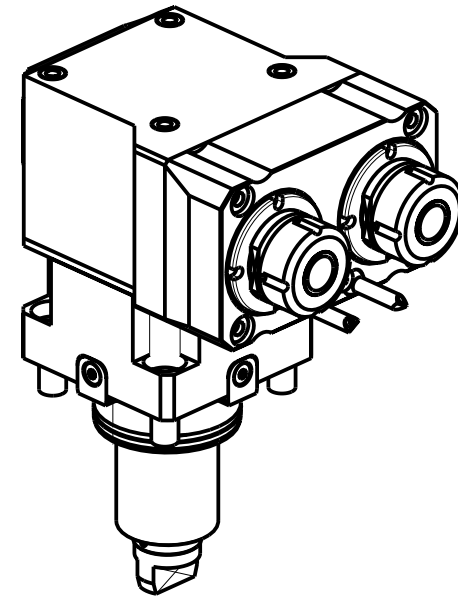

Cod. MT	Mandrino Spindle Spindel	I	RPM	Coppia Max Max Torque Max Drehmoment	Reversibile lato mandrino/contromandrino Reversible sub/main spindle side Umkehrbare Spindel-seite/Gegenspindel-seite	Lubrificazione est. Ext. coolant Aussenkuehlung	CHIAVI NON INCLUSE Keys not included Schluessel nicht einbegriffen	
DW01230225	ER25	1:1	6000	40Nm	X	X	CHUB36	CHSTER25

GOODWAY
 MOD: GTX2000/2600 12ST. - GTZ2000/2600 12ST. - GS2000/2800 16ST. - GMT2000 - GLS2800/3300 12ST.

MODULO MOTORIZZATO ASSIALE 2 USCITE IN Y H=100mm
 Axial single side twin head driven tool in Y H=100mm
 Axial angetriebenes Werkzeug 2 Ausgaenge in Y H=100mm

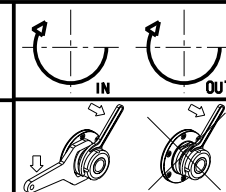

M.T. srl
 Via Casino Albini 480
 Tel. 0541/956034-957884
 Fax 0541/956341
 47842 S. GIOVANNI IN M. (RN)
 e-mail: mtma@mtmarchetti.com
 http://www.mtmarchetti.com

PRODUZIONE MODULI ROTANTI



PAGINA GDW 260-4-30

Subject to change without notice.

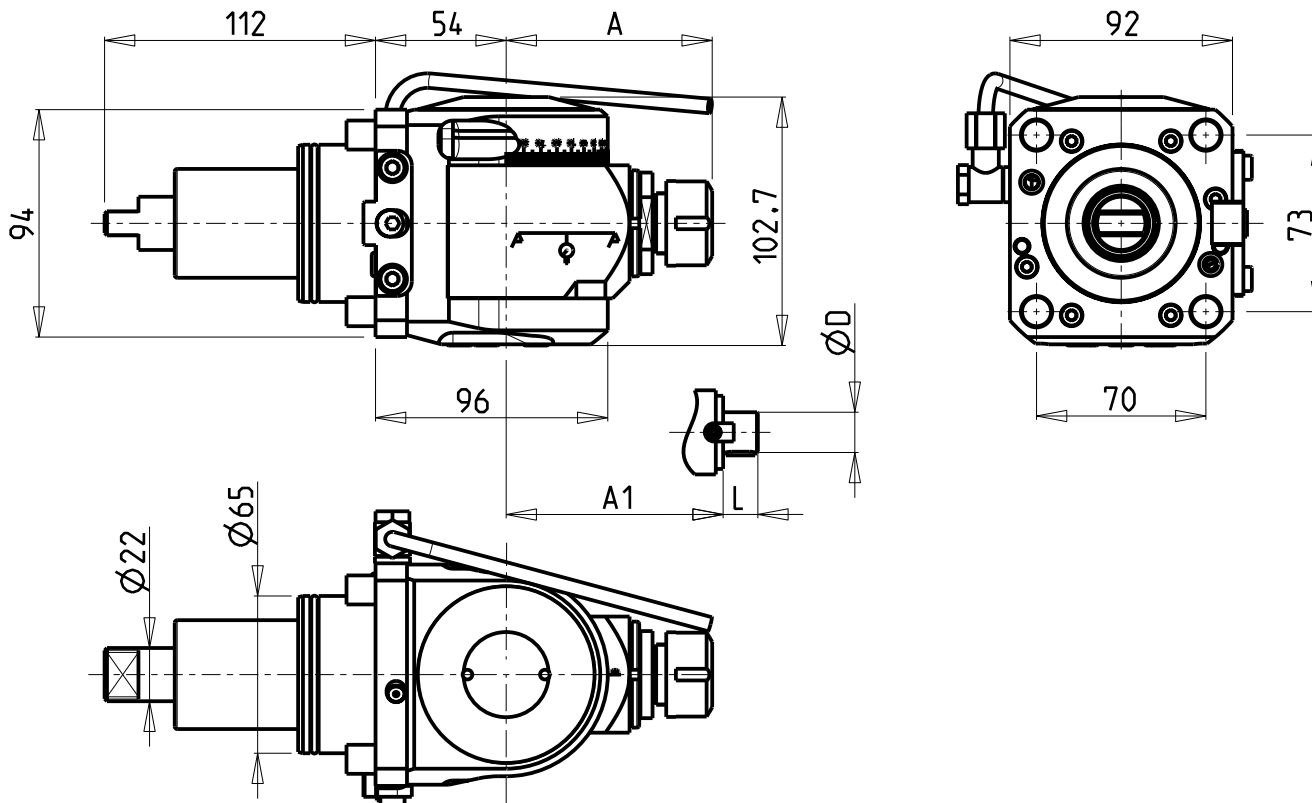

ATTENZIONE - ATTENTION - ACHTUNG

- VERIFICARE LE MISURE DI INGOMBRO PER POSSIBILE INTERFERENZA SU ALCUNI MODELLI DI MACCHINE
- Please check the overall sizes for possible interferences on some machine models
- Bitte überprüfen sie das ausmass um mögliche interferenzen auf einigen maschinen modellen zu vermeiden

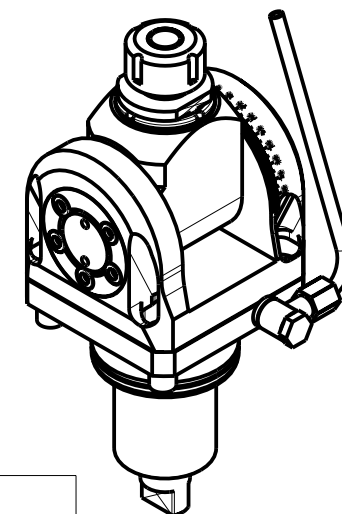

Cod. MT	Mandrino Spindle Spindel	I	RPM	Coppia Max Max Torque Max Drehmoment	Reversibile lato mandrino/contromandrino Reversible sub/main spindle side Umkehrbare Spindelseite/ Gegenspindelseite	Lubrificazione est. Ext. coolant Aussehenkuehlung	A	A1	D	L	CHIAVI INCLUSE Keys included Schlüssel inbegriffen		
											CH_VTCROCE_M08	CHUB36	CHESL10
DW 01920120	ER20	1:1	6000	40Nm	X	X	85.16	-	-	-	CHSTER20	CHUB36	CHESL10
DW 01920125	ER25	1:1	6000	40Nm	X	X	86.16	-	-	-	CHSTER25	CHUB36	CHESL10
DW 01920516	Ø16x17	1:1	6000	40Nm	X	X	-	65	16	17	CH_VTCROCE_M08	CHUB36	CHESL10
DW 01920522	Ø22x19	1:1	6000	40Nm	X	X	-	66	22	19	CH_VTCROCE_M10	CHUB36	CHESL10
DW 01920519	Ø3/4"x3/4"	1:1	6000	40Nm	X	X	-	65	3/4"	3/4"	CH_VTCROCE_M08	CHUB36	CHESL10

GOODWAY

MOD: GTX2000/2600 12ST. - GTZ2000/2600 12ST. - GS2000/2800 16ST. - GMT2000 - GMS2000 15ST. - GLS2800/3300 12ST.

MODULO MOTORIZZATO ORIENTABILE ±90° H=54mm

±90° adjustable angle driven tool H=54mm

Angetriebenes Werkzeug schwenkbar ±90° H=54mm

Subject to change without notice.

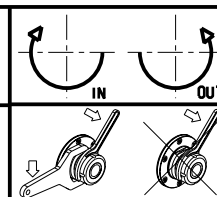

M.T. srl

Via Casino Albini 480
Tel. 0541/956034-957884
Fax 0541/956341
47842 S. GIOVANNI IN M. (RN)
e-mail: mtma@mtmarchetti.com
http://www.mtmarchetti.com

PRODUZIONE MODULI ROTANTI



PAGINA GDW 333-4-00

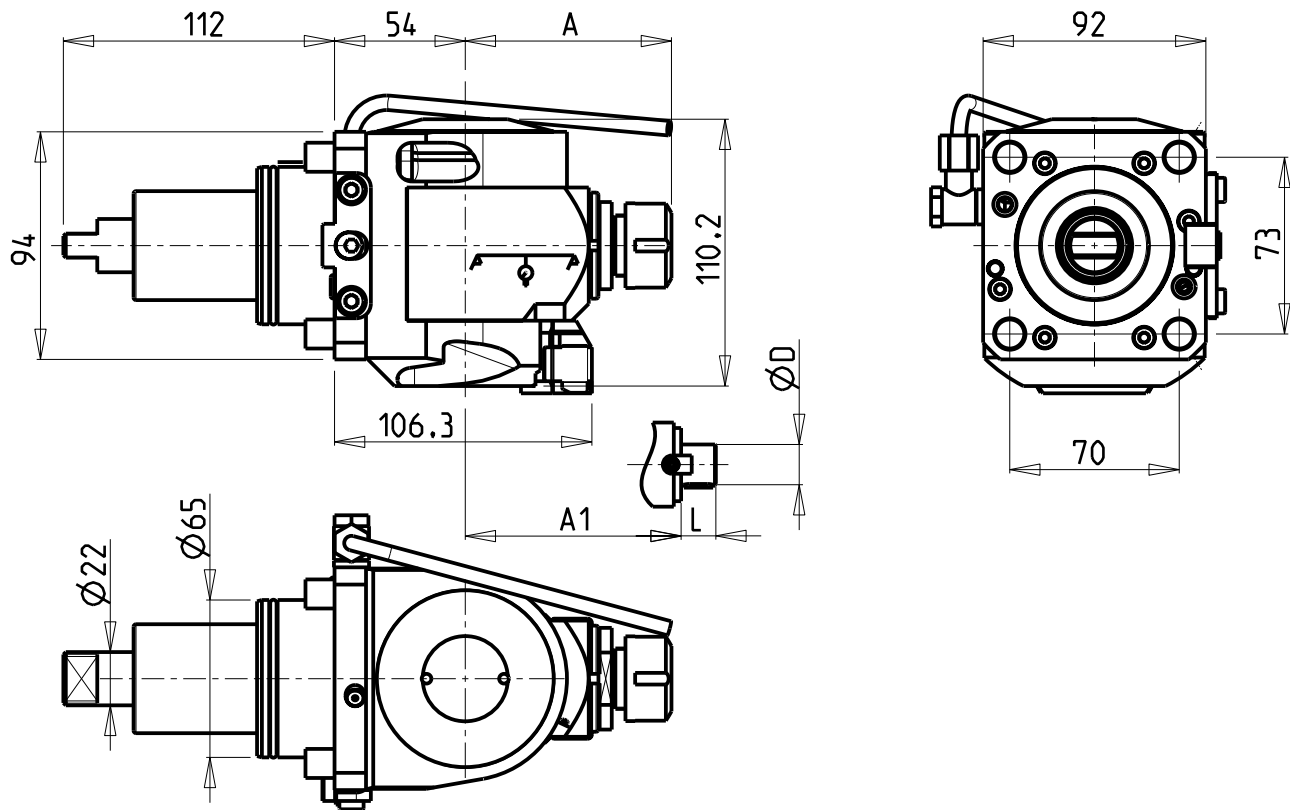

ATTENZIONE - ATTENTION - ACHTUNG

- VERIFICARE LE MISURE DI INGOMBRO PER POSSIBILE INTERFERENZA SU ALCUNI MODELLI DI MACCHINE
- Please check the overall sizes for possible interferences on some machine models
- Bitte überprüfen sie das ausmass um mögliche interferenzen auf einigen maschinen modellen zu vermeiden

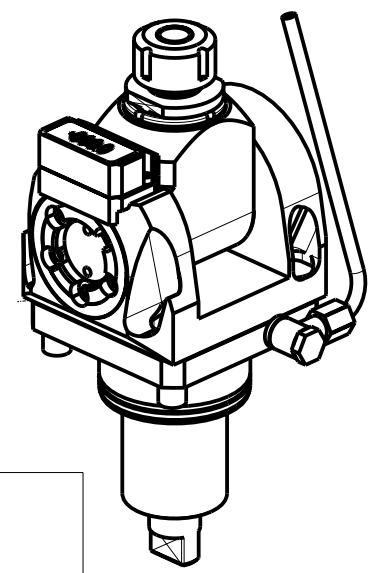

Cod. MT	Mandrino Spindle Spindel	I	RPM	Coppia Max Max Torque Max Drehmoment	Reversibile lato mandrino/contromandrino Reversible sub/main spindle side Umkehrbare Spindelseite/ Gegenspindelseite	Lubrificazione est. Ext. coolant Aussehenkuehlung	A	A1	D	L	CHIAVI INCLUSE Keys included Schlüssel inbegriffen		
											CH_VTCROCE_M08	CHUB36	CHESL10
DW 01850120	ER20	1:1	6000	40Nm	X	X	85.16	-	-	-	CHSTER20	CHUB36	CHESL10
DW 01850125	ER25	1:1	6000	40Nm	X	X	86.16	-	-	-	CHSTER25	CHUB36	CHESL10
DW 01850516	Ø16x17	1:1	6000	40Nm	X	X	-	65	16	17	CH_VTCROCE_M08	CHUB36	CHESL10
DW 01850522	Ø22x19	1:1	6000	40Nm	X	X	-	66	22	19	CH_VTCROCE_M10	CHUB36	CHESL10
DW 01850519	Ø3/4"x3/4"	1:1	6000	40Nm	X	X	-	65	3/4"	3/4"	CH_VTCROCE_M08	CHUB36	CHESL10

GOODWAY

MOD: GTX2000/2600 12ST. - GTZ2000/2600 12ST. - GS2000/2800 16ST. - GMT2000 - GMS2000 15ST. - GLS2800/3300 12ST.

MODULO MOTORIZZATO ORIENTABILE ±90° CON NONIO DIGITALE H=54mm
 ±90° adjustable angle driven tool with digital display H=54mm
 Angetriebenes Werkzeug schwenkbar ±90° mit digital display H=54mm

Subject to change without notice.

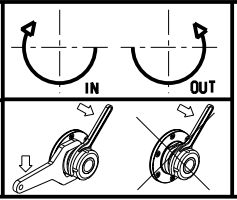

M.T. srl
 Via Casino Albini 480
 Tel. 0541/956034-957884
 Fax 0541/956341
 47842 S. GIOVANNI IN M. (RN)
 e-mail: mtma@mtmarchetti.com
 http://www.mtmarchetti.com

PRODUZIONE MODULI ROTANTI

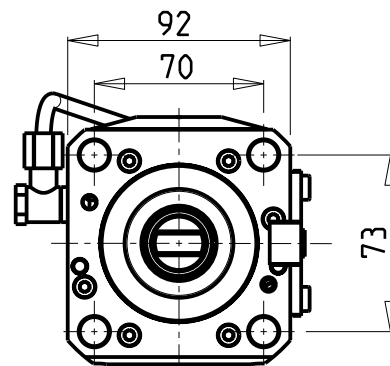
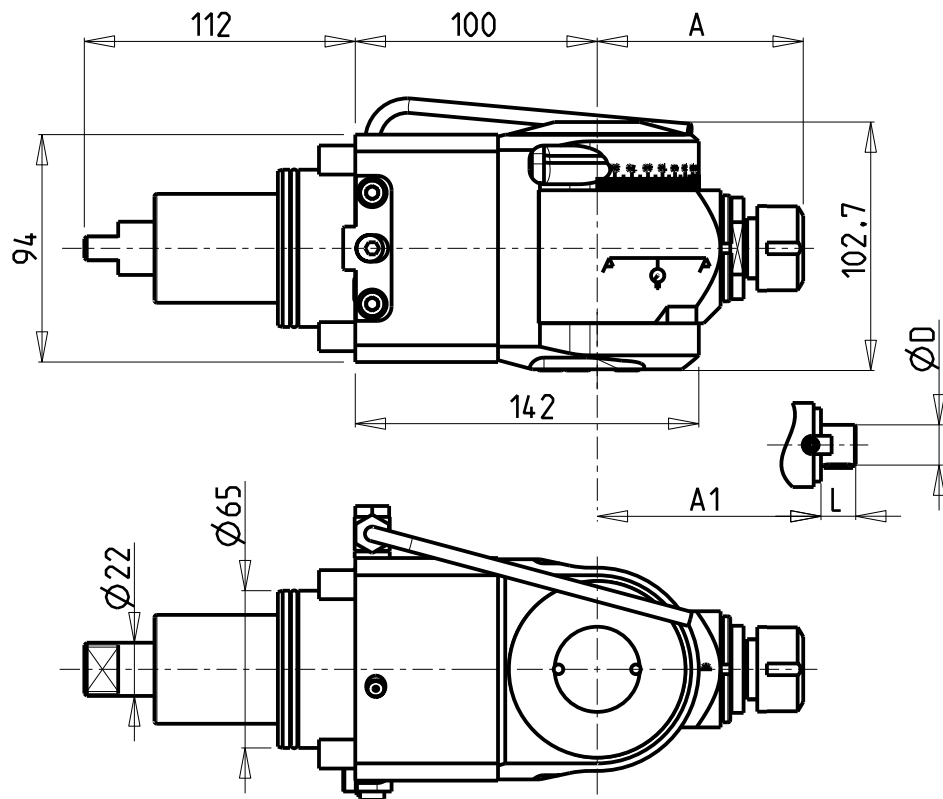
 PAGINA GDW 333-4-01

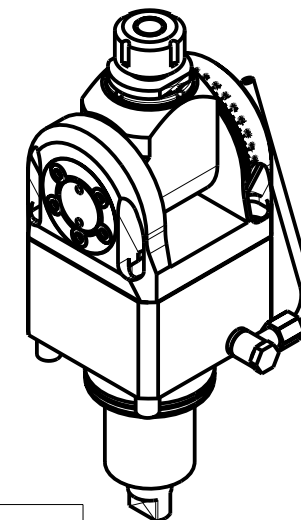

ATTENZIONE - ATTENTION - ACHTUNG

- VERIFICARE LE MISURE DI INGOMBRO PER POSSIBILE INTERFERENZA SU ALCUNI MODELLI DI MACCHINE
- Please check the overall sizes for possible interferences on some machine models
- Bitte überprüfen sie das ausmass um mögliche interferenzen auf einigen maschinen modellen zu vermeiden



Cod. MT	Mandrino Spindle Spindel	I	RPM	Coppia Max Max Torque Max Drehmoment	Reversibile lato mandrino/contromandrino Reversible sub/main spindle side Umkehrbare Spindel-seite/ Gegenspindel-seite	Lubrificazione est. Ext. coolant Aussehenkuehlung	A	A1	D	L	CHIAVI INCLUSE Keys included Schlüssel inbegriffen		
											CH_VTCROCE_M08	CHUB36	CHESL10
DW 01930120	ER20	1:1	6000	40Nm	X	X	85.16	-	-	-	CHSTER20	CHUB36	CHESL10
DW 01930125	ER25	1:1	6000	40Nm	X	X	86.16	-	-	-	CHSTER25	CHUB36	CHESL10
DW 01930516	Ø16x17	1:1	6000	40Nm	X	X	-	65	16	17	CH_VTCROCE_M08	CHUB36	CHESL10
DW 01930522	Ø22x19	1:1	6000	40Nm	X	X	-	66	22	19	CH_VTCROCE_M10	CHUB36	CHESL10
DW 01930519	Ø3/4"x3/4"	1:1	6000	40Nm	X	X	-	65	3/4"	3/4"	CH_VTCROCE_M08	CHUB36	CHESL10

GOODWAY

MOD: GTX2000/2600 12ST. - GTZ2000/2600 12ST. - GS2000/2800 16ST. - GMT2000 - GMS2000 15ST. - GLS2800/3300 12ST.

MODULO MOTORIZZATO ORIENTABILE ±90° H=100mm

±90° adjustable angle driven tool H=100mm

Angetriebenes Werkzeug schwenkbar ±90° H=100mm

Subject to change without notice.

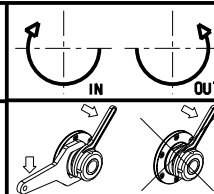

M.T. srl

Via Casino Albini 480
Tel. 0541/956034-957884
Fax 0541/956341
47842 S. GIOVANNI IN M. (RN)
e-mail: mtma@mtmarchetti.com
http://www.mtmarchetti.com

PRODUZIONE MODULI ROTANTI



PAGINA GDW 333-4-10

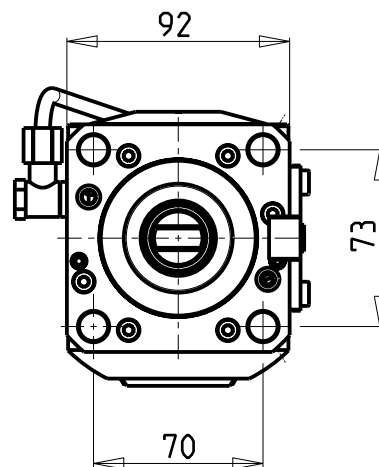
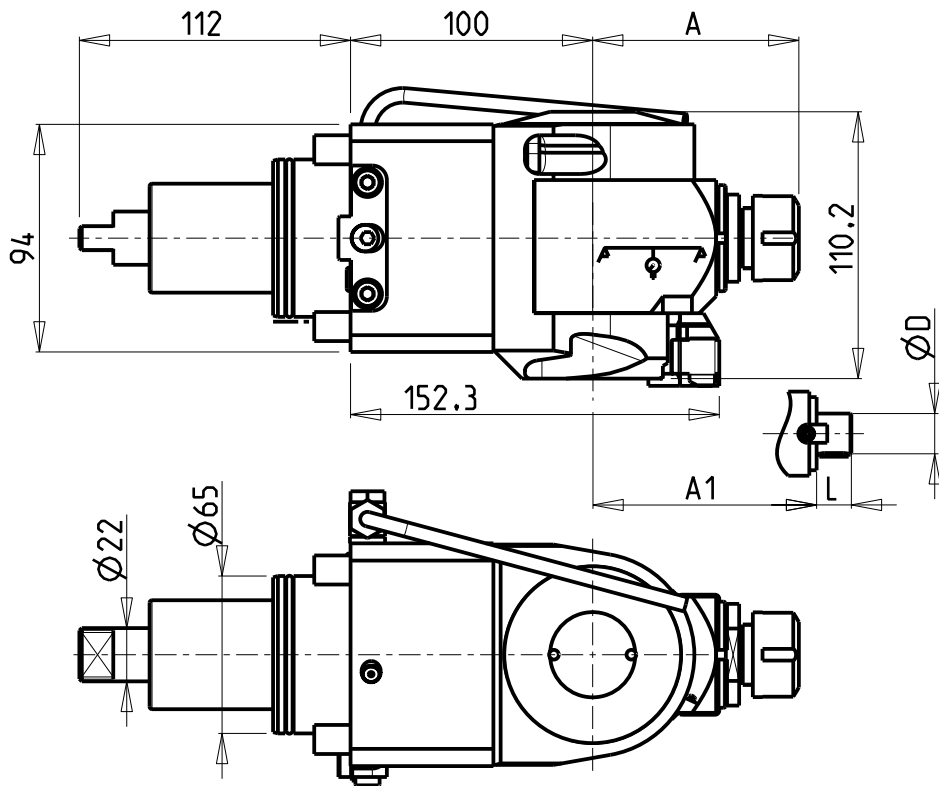

ATTENZIONE - ATTENTION - ACHTUNG

- VERIFICARE LE MISURE DI INGOMBRO PER POSSIBILE INTERFERENZA SU ALCUNI MODELLI DI MACCHINE
- Please check the overall sizes for possible interferences on some machine models
- Bitte überprüfen sie das ausmass um mögliche interferenzen auf einigen maschinen modellen zu vermeiden

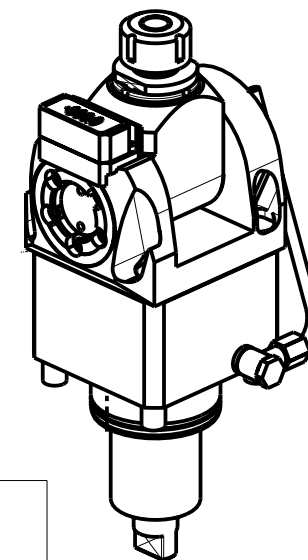

Cod. MT	Mandrino Spindle Spindel	I	RPM	Coppia Max Max Torque Max Drehmoment	Reversibile lato mandrino/contromandrino Reversible sub/main spindle side Umkehrbare Spindelseite/ Gegenspindelseite	Lubrificazione est. Ext. coolant Aussehenkuehlung	A	A1	D	L	CHIAVI INCLUSE Keys included Schlüssel inbegriffen		
											CH_VTCROCE_M08	CHUB36	CHESL10
DW 01860120	ER20	1:1	6000	40Nm	X	X	85.16	-	-	-	CHSTER20	CHUB36	CHESL10
DW 01860125	ER25	1:1	6000	40Nm	X	X	86.16	-	-	-	CHSTER25	CHUB36	CHESL10
DW 01860516	Ø16x17	1:1	6000	40Nm	X	X	-	65	16	17	CH_VTCROCE_M08	CHUB36	CHESL10
DW 01860522	Ø22x19	1:1	6000	40Nm	X	X	-	66	22	19	CH_VTCROCE_M10	CHUB36	CHESL10
DW 01860519	Ø3/4"x3/4"	1:1	6000	40Nm	X	X	-	65	3/4"	3/4"	CH_VTCROCE_M08	CHUB36	CHESL10

GOODWAY

MOD: GTX2000/2600 12ST. - GTZ2000/2600 12ST. - GS2000/2800 16ST. - GMT2000 - GMS2000 15ST. - GLS2800/3300 12ST.

MODULO MOTORIZZATO ORIENTABILE ±90° CON NONIO DIGITALE H=100mm

±90° adjustable angle driven tool with digital display H=100mm

Angetriebenes Werkzeug schwenkbar ±90° mit digital display H=100mm

Subject to change without notice.

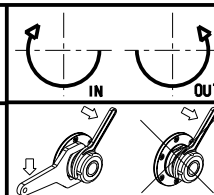

M.T. srl

Via Casino Albini 480
Tel. 0541/956034-957884
Fax 0541/956341
47842 S. GIOVANNI IN M. (RN)
e-mail: mtma@mtmarchetti.com
http://www.mtmarchetti.com

PRODUZIONE MODULI ROTANTI



PAGINA GDW 333-4-11

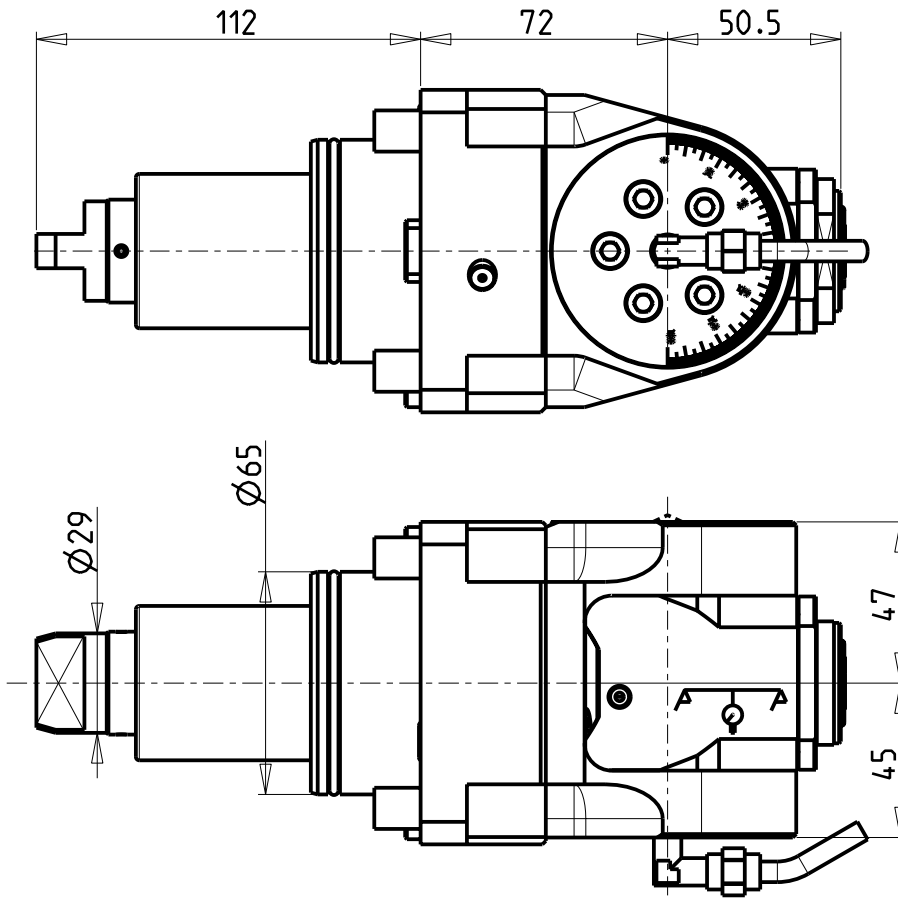
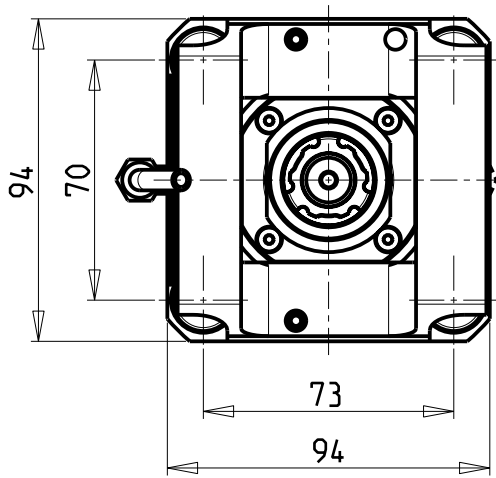

ATTENZIONE - ATTENTION - ACHTUNG

- Per lo smontaggio degli utensili utilizzare sempre la chiave di contrasto come indicato nel manuale d'uso.
- For disassembly of the tools use always the contrast key as mentioned in the user instructions.
- Fuer das Abmontieren der Werkzeuge immer den Gegenschlüssel benutzen wie in der Bedienungsanleitung erwaeht.

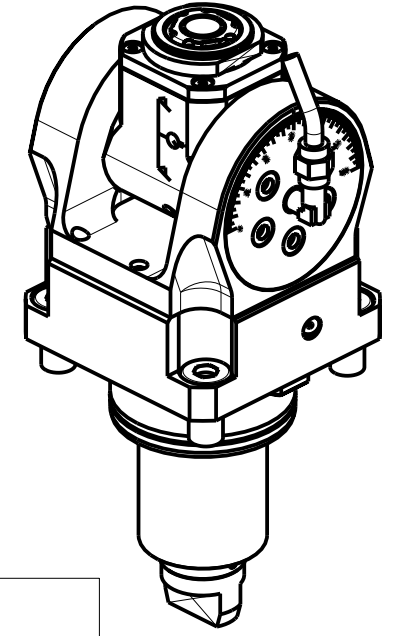

Cod. MT	Mandrino Spindle Spindel	I	RPM	Coppia Max Max Torque Max Drehmoment	Reversibile lato mandrino/contromandrino	Lubrificazione int. Coolant through Innenkuehlung	Lubrificazione est. Ext. coolant Aussenkuehlung	CHIAVI INCLUSE Keys included Schluessel inbegriffen			
					Reversible sub/main spindle side Umkehrbare Spindel-seite/ Gegenspindel-seite						
DW01940120	ERA20	1:1	6000	30Nm	X	-	X	CHUB36	CHUB22	CHTAER20ZC	CHESL08
DW01940220	ERA20	1:1	6000	30Nm	X	P=70bar	X	CHUB36	CHUB22	CHTAER20ZC	CHESL08

GOODWAY

MOD: GTX2000/2600 12ST. - GTZ2000/2600 12ST. - GS2000/2800 16ST. - GMT2000 - GMS2000 15ST. - GLS2800/3300 12ST.

MODULO MOTORIZZATO ORIENTABILE ±90° H=72mm
 ±90° adjustable angle driven tool H=72mm
 Angetriebenes Werkzeug schwenkbar ±90° H=72mm

Subject to change without notice.

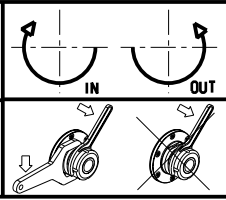

M.T. srl
 Via Casino Albini 480
 Tel. 0541/956034-957884
 Fax 0541/956341
 47842 S. GIOVANNI IN M. (RN)
 e-mail: mtma@mtmarchetti.com
 http://www.mtmarchetti.com

PRODUZIONE MODULI ROTANTI

 PAGINA GDW 335-4-00

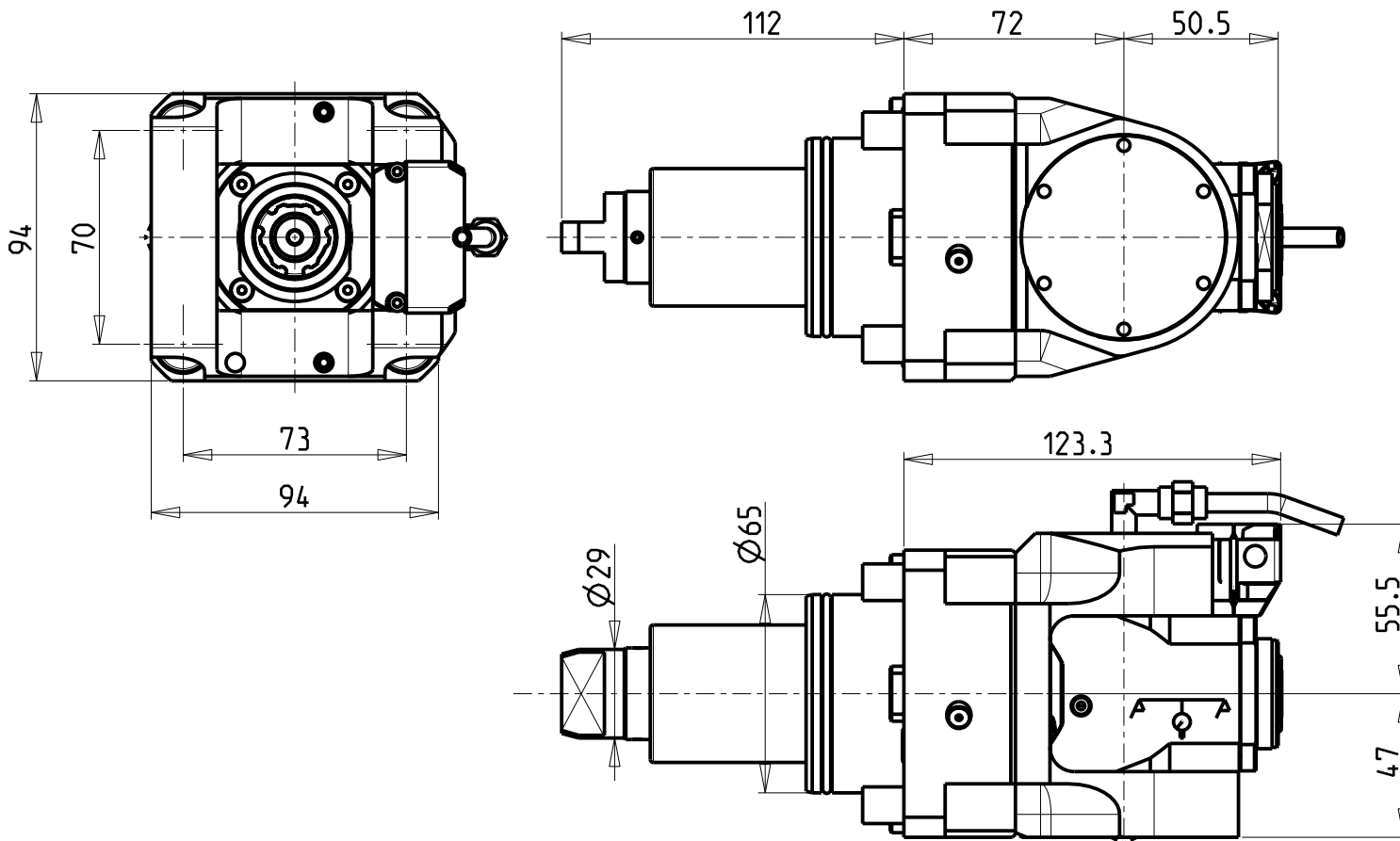

ATTENZIONE - ATTENTION - ACHTUNG

- Per lo smontaggio degli utensili utilizzare sempre la chiave di contrasto come indicato nel manuale d'uso.
- For disassembly of the tools use always the contrast key as mentioned in the user instructions.
- Fuer das Abmontieren der Werkzeuge immer den Gegenschlüssel benutzen wie in der Bedienungsanleitung erwaeht.

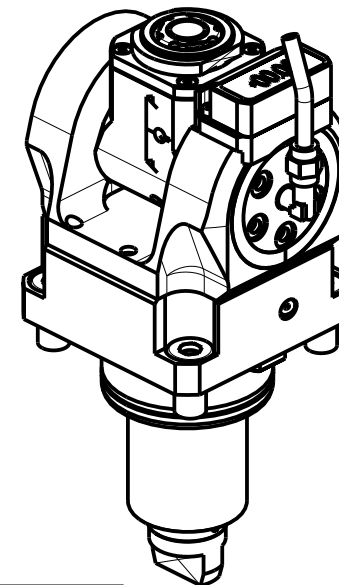

Cod. MT	Mandrino Spindle Spindel	I	RPM	Coppia Max Max Torque Max Drehmoment	Reversibile lato mandrino/contromandrino Reversible sub/main spindle side Umkehrbare Spindel-seite/ Gegenspindel-seite	Lubrificazione int. Coolant through Innenkuehlung	Lubrificazione est. Ext. coolant Ausseinkuehlung	CHIAVI INCLUDE Keys included Schluessel inbegriffen			
								CHUB36	CHUB22	CHTAER20ZC	CHESL08
DW01945120	ERA20	1:1	6000	30Nm	X	-	X	CHUB36	CHUB22	CHTAER20ZC	CHESL08
DW01945220	ERA20	1:1	6000	30Nm	X	P=70bar	X	CHUB36	CHUB22	CHTAER20ZC	CHESL08

GOODWAY

MOD: GTX2000/2600 12ST. - GTZ2000/2600 12ST. - GS2000/2800 16ST. - GMT2000 - GMS2000 15ST. - GLS2800/3300 12ST.

MODULO MOTORIZZATO ORIENTABILE ±90° CON NONIO DIGITALE H=72mm

±90° adjustable angle driven tool with digital display H=72mm

Angetriebenes Werkzeug schwenkbar ±90° mit digital display H=72mm

Subject to change without notice.

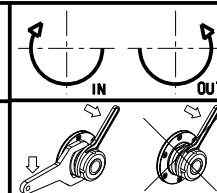

M.T. srl

Via Casino Albini 480
Tel. 0541/956034-957884
Fax 0541/956341
47842 S. GIOVANNI IN M. (RN)
e-mail: mtma@mtmarchetti.com
http://www.mtmarchetti.com

PRODUZIONE MODULI ROTANTI



PAGINA GDW 335-4-01

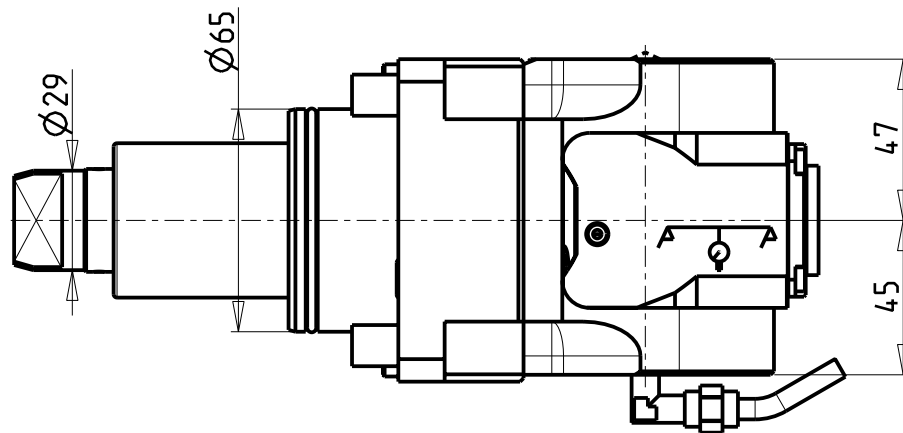
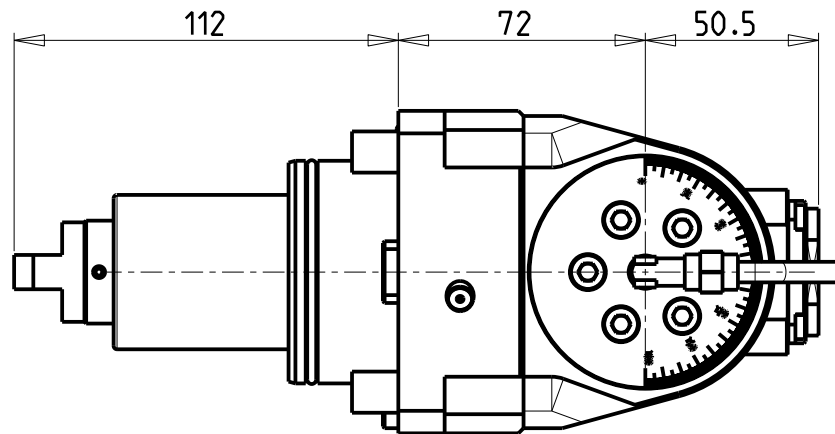
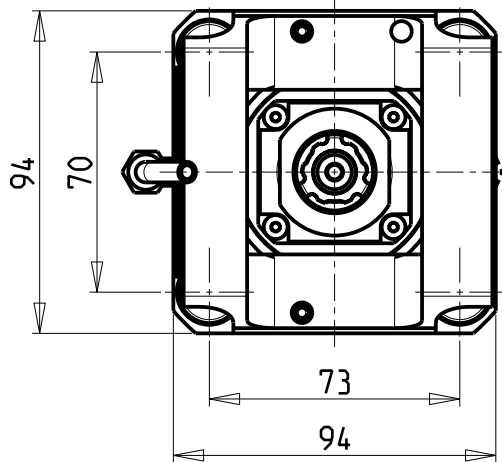

ATTENZIONE - ATTENTION - ACHTUNG

- Per lo smontaggio degli utensili utilizzare sempre la chiave di contrasto come indicato nel manuale d'uso.
- For disassembly of the tools use always the contrast key as mentioned in the user instructions.
- Fuer das Abmontieren der Werkzeuge immer den Gegenschlüssel benutzen wie in der Bedienungsanleitung erwaeht.

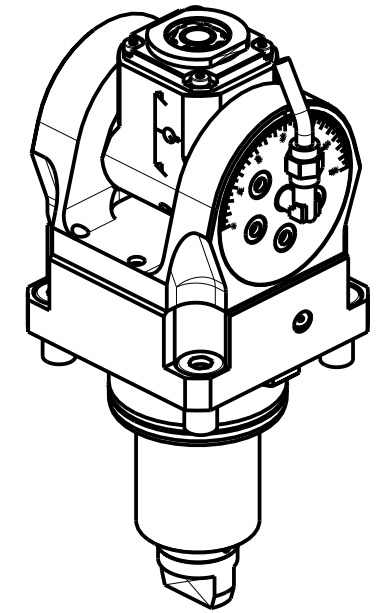

Cod. MT	Mandrino Spindle Spindel	i	RPM	Coppia Max Max Torque Max Drehmoment	Reversibile lato mandrino/contromandrino Reversible sub/main spindle side Umkehrbare Spindel-seite/ Gegenspindel-seite	Lubrificazione int. Coolant through Innenkuehlung	Lubrificazione est. Ext. coolant Aussenkuehlung	CHIAVI INCLUDE Keys included Schluessel inbegriffen			
					X	-	X	CHUB19_SP3	CHUB32	CHTAER16ZC	CHESL08
DW01940316	ERA16	1:2	12000	8Nm	X	-	X	CHUB19_SP3	CHUB32	CHTAER16ZC	CHESL08
DW01940416	ERA16	1:2	12000	8Nm	X	P=70bar	X	CHUB19_SP3	CHUB32	CHTAER16ZC	CHESL08

GOODWAY

MOD: GTX2000/2600 12ST. - GTZ2000/2600 12ST. - GS2000/2800 16ST. - GMT2000 - GMS2000 15ST. - GLS2800/3300 12ST.

MODULO MOTORIZZATO ORIENTABILE ±90° MOLTIPLICATO I=1:2 H=72mm

±90° adjustable angle driven tool geared-up I=1:2 H=72mm

Angetriebenes Werkzeug schwenkbar ±90° uebersetzt I=1:2 H=72mm

Subject to change without notice.

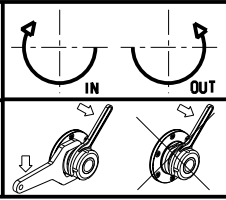

M.T. srl
 Via Casino Albini 480
 Tel. 0541/956034-957884
 Fax 0541/956341
 47842 S. GIOVANNI IN M. (RN)
 e-mail: mtma@mtmarchetti.com
 http://www.mtmarchetti.com

PRODUZIONE MODULI ROTANTI



PAGINA GDW 336-4-00

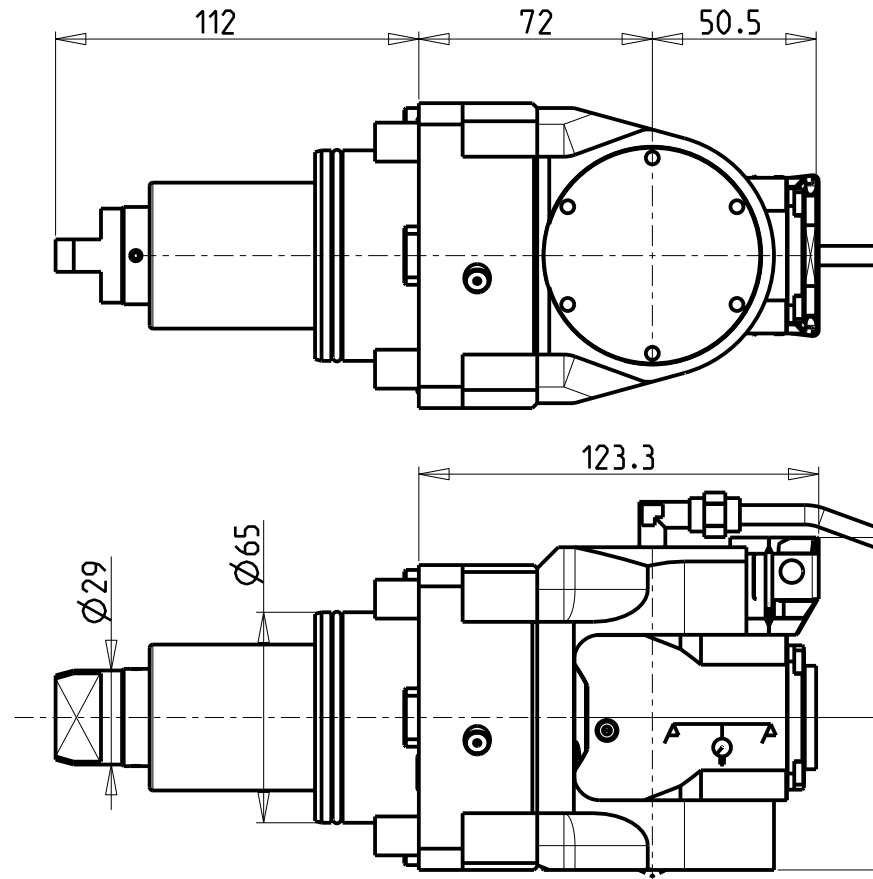
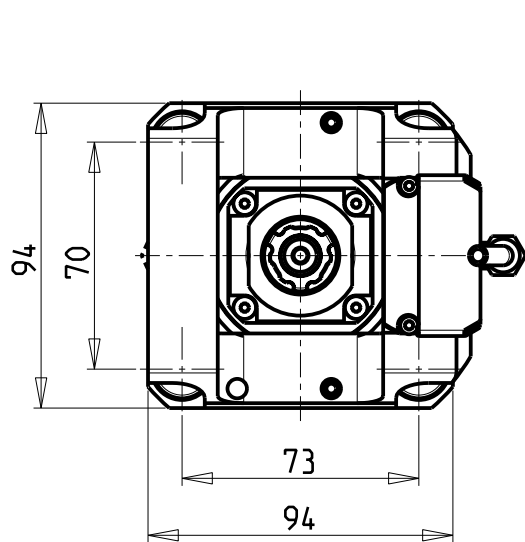

ATTENZIONE - ATTENTION - ACHTUNG

- Per lo smontaggio degli utensili utilizzare sempre la chiave di contrasto come indicato nel manuale d'uso.
- For disassembly of the tools use always the contrast key as mentioned in the user instructions.
- Fuer das Abmontieren der Werkzeuge immer den Gegenschlüssel benutzen wie in der Bedienungsanleitung erwaeht.

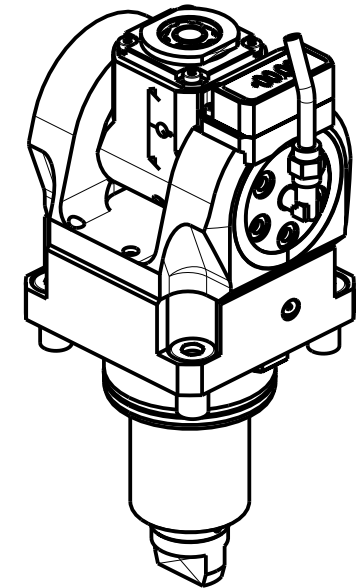

Cod. MT	Mandrino Spindle Spindel	I	RPM	Coppia Max Max Torque Max Drehmoment	Reversibile lato mandrino/contromandrino Reversible sub/main spindle side Umkehrbare Spindel-seite/ Gegenspindel-seite	Lubrificazione int. Coolant through Innenkuehlung	Lubrificazione est. Ext. coolant Ausseinkuehlung	CHIAVI INCLUDE Keys included Schluessel inbegriffen			
								CHUB19_SP3	CHUB32	CHTAER16ZC	CHESL08
DW01945316	ERA16	1:2	12000	8Nm	X	-	X	CHUB19_SP3	CHUB32	CHTAER16ZC	CHESL08
DW01945416	ERA16	1:2	12000	8Nm	X	P=70bar	X	CHUB19_SP3	CHUB32	CHTAER16ZC	CHESL08

GOODWAY

MOD: GTX2000/2600 12ST. - GTZ2000/2600 12ST. - GS2000/2800 16ST. - GMT2000 - GMS2000 15ST. - GLS2800/3300 12ST.

MODULO MOTORIZZATO ORIENTABILE ±90° MOLTIPLICATO I=1:2 CON NONIO DIGITALE H=72mm
 ±90° adjustable angle driven tool geared-up I=1:2 with digital display H=72mm
 Angetriebenes Werkzeug schwenkbar ±90° uebersetzt I=1:2 mit digital display H=72mm

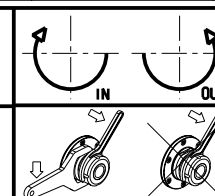

M.T. srl

Via Casino Albini 480
 Tel. 0541/956034-957884
 Fax 0541/956341
 47842 S. GIOVANNI IN M. (RN)
 e-mail: mtma@tmarchetti.com
 http://www.tmmarchetti.com

PRODUZIONE MODULI ROTANTI



PAGINA GDW 336-4-01

Subject to change without notice.

10/2018

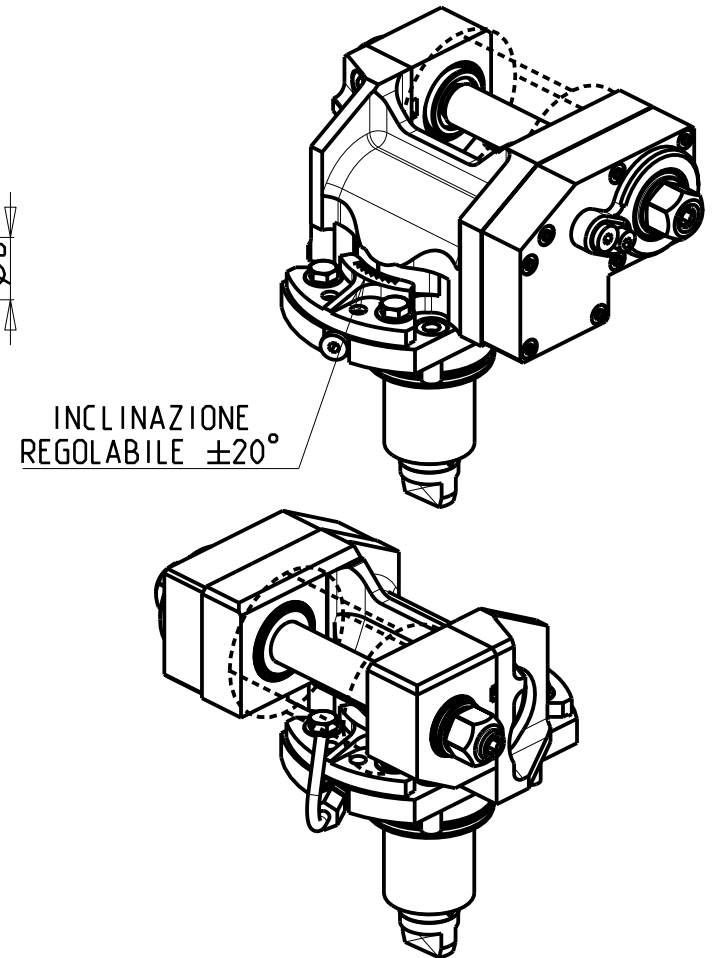
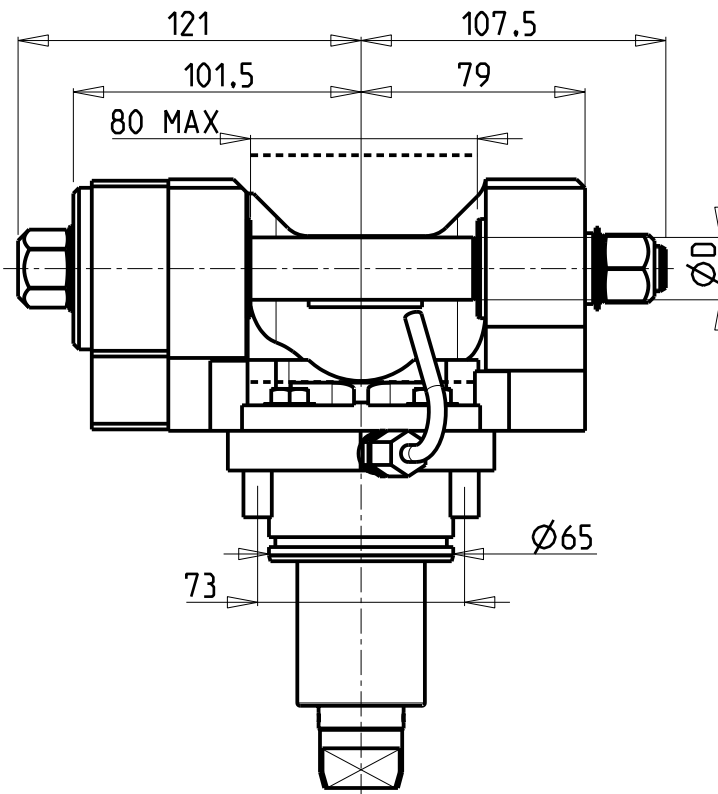
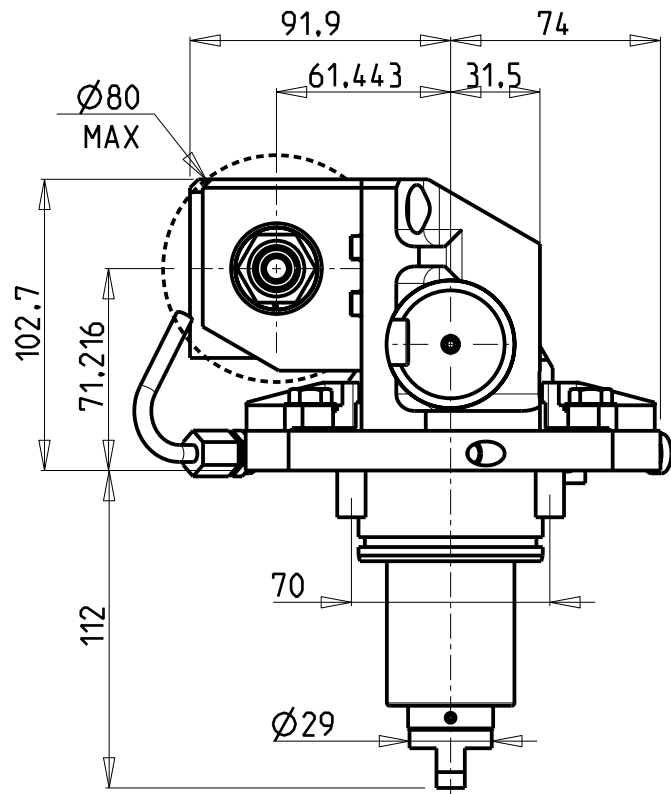

INCLINAZIONE
REGOLABILE $\pm 20^\circ$

DOTAZIONI - SUPPLIED WITH - AUSSTATTUNG

- mm / inch - N°1 ALBERO + DISTANZIALI
- mm / inch - N°1 SHAFT + SPACER
- mm / inch - N°1 DORN + ABSTANDSSTUECK

PER ALBERI E DISTANZIALI VEDI PAG. TBL250-1-00
FOR SHAFT END SPACER SEE PAGE TBL250-1-00
FUER DORN UND ABSTANDSSTUECK SEITE TBL250-1-00

Cod. MT	I	RPM	Coppia Max Max Torque Max Drehmoment	Reversibile lato mandrino/contromandrino Reversible sub/main spindle side Umkehrbare Spindel-seite/ Gegenspindel-seite	Lubrificazione est. Ext. coolant Aussenkuehlung	D (mm)	D (Inch)	CHIAVI INCLUSE Keys included Schlüssel inbegriffen		
				X				X	CHUB24	CHUB13
0321100	1:1	6000	60Nm	X	X	16-22-27-32	3/4"-1"-1 1/4"	CHUB24	CHUB13	CHESL08
0322100	2:1	3000	80Nm	X	X	16-22-27-32	3/4"-1"-1 1/4"	CHUB24	CHUB13	CHESL08

GOODWAY

MOD: GTX2000/2600 12ST. - GTZ2000/2600 12ST. - GS2000/2800 16ST. - GMT2000 - GMS2000 15ST. - GLS2800/3300 12ST.

MODULO MOTORIZZATO PORTACREATORE

Driven gear hobber

Angetriebenes Zahnradwaeltzraes-Werkzeug

Subject to change without notice.

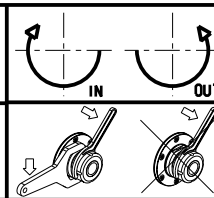

M.T. srl

Via Casino Albini 480
Tel. 0541/956034-957884
Fax 0541/956341
47842 S. GIOVANNI IN M. (RN)
e-mail: mtma@tmarchetti.com
http://www.tmmarchetti.com

PRODUZIONE MODULI ROTANTI



PAGINA GDW 340-4-00

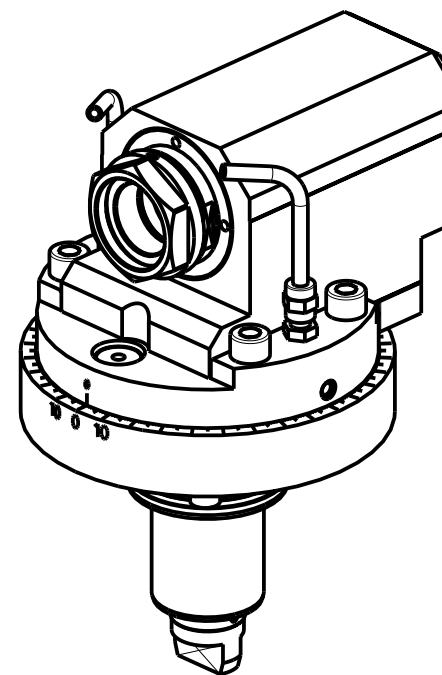
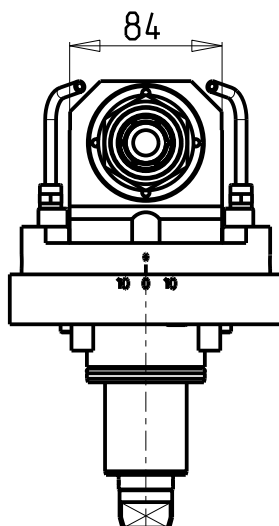
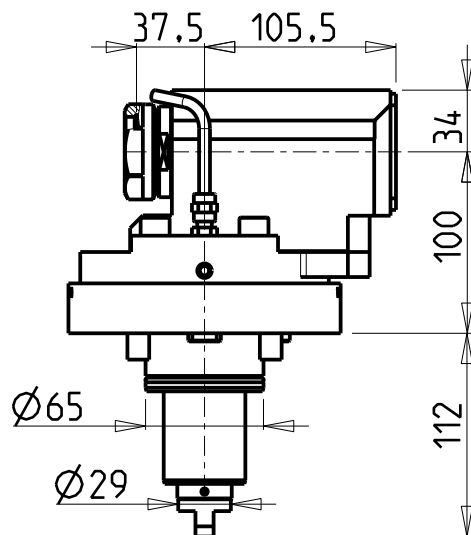
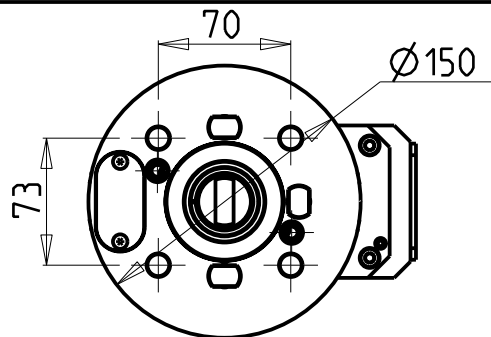

ATTENZIONE - ATTENTION - ACHTUNG

- VERIFICARE LE MISURE DI INGOMBRO PER POSSIBILE INTERFERENZA SU ALCUNI MODELLI DI MACCHINE
- Please check the overall sizes for possible interferences on some machine models
- Bitte überprüfen sie das ausmass um mögliche interferenzen auf einigen maschinen modellen zu vermeiden

PER PORTAUTENSILI MODULARI MTSK-40 VEDI PAG. TBL300-1-40
 FOR MTSK-40 QUICK CHANGE TOOLHOLDERS CLAMPINGS SEE PAGE TBL300-1-40
 FUER MTSK-40 MODULARE WERKZEUGAUFNAHMEN SIEHE SEITE TBL300-1-40

Cod. MT	Mandrino Spindle Spindel	I	RPM	Coppia Max Max Torque Max Drehmoment	Reversibile lato mandrino/contromandrino Reversible sub/main spindle side Umkehrbare Spindel-seite/Gegenspindel-seite	Lubr.esterna Ext. coolant Aussenkuehlung	CHIAVI INCLUDE Keys included Schluessel einbegriffen
DW01770100	MTSK-40	1:1	6000	50Nm	X	X	n°2 CHUB46

GOODWAY

MOD: GTX2000/2600 12ST. - GTZ2000/2600 12ST. - GS2000/2800 16ST. - GMT2000 - GLS2800/3300 12ST.

MODULO MOTORIZZATO ASSIALE MTSK PER POWER SKIVING H=100mm

Axial MTSK driven tool for Power Skiving H=100mm

Axial MTSK angetriebenes Werkzeug fuer Power Skiving H=100mm

Subject to change without notice.

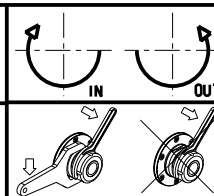

M.T. srl

Via Casino Albini 480
 Tel. 0541/956034-957884
 Fax 0541/956341

47842 S. GIOVANNI IN M. (RN)
 e-mail: mtma@mtmarchetti.com
 http://www.mtmarchetti.com

PRODUZIONE MODULI ROTANTI



PAGINA GDW 350-4-00-K

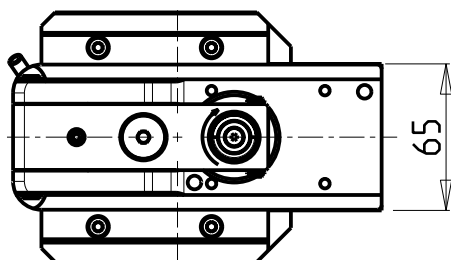
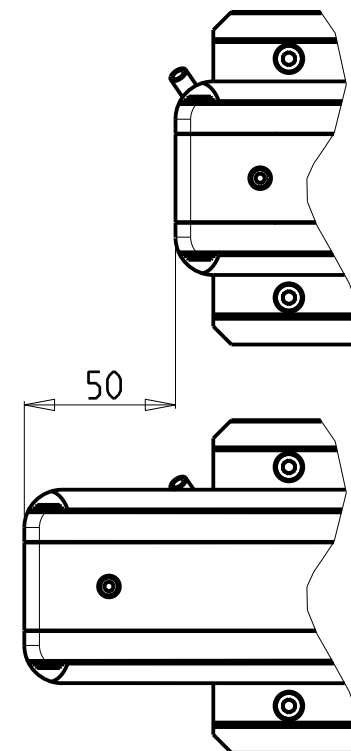
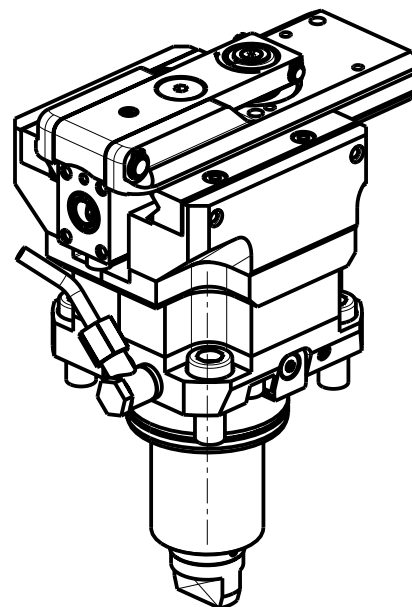
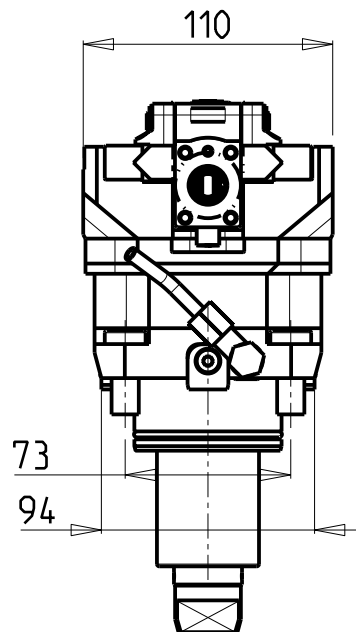
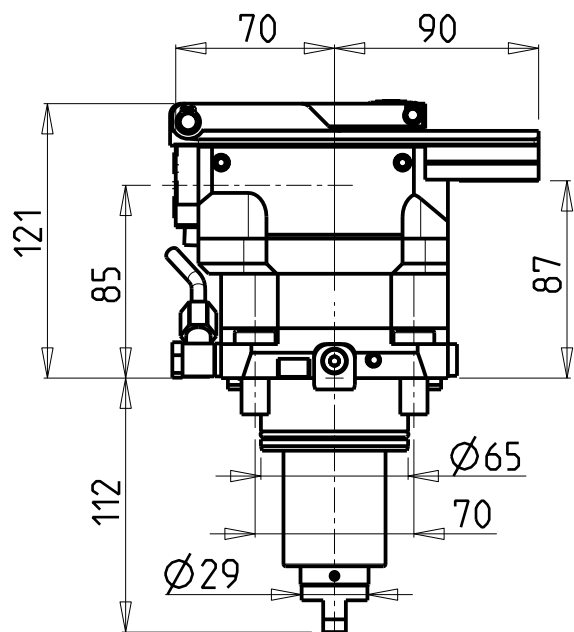

PER UTENSILI STOZZATORI VEDI PAG. TBL400-1-00
 FOR DRIVEN SLOTTING TOOL CUTTING-TOOLS SEE PAGE TBL400-1-00
 FÜR NUTENSTOSS-WERKZEUG SCHNEIDWERKZEUGE SIEHE SEITE TBL400-1-00

Cod. MT	I	RPM MAX	Reversibile lato mandrino/contromandrino Reversible sub/main spindle side Umkehrbare Spindel-seite/ Gegenspindel-seite	Lubr. esterna Ext. coolant Aussenkuehlung
DW 01530100	4:1	2000	X	X

GOODWAY

MOD: GTX2000/2600 12ST. - GTZ2000/2600 12ST. - GS2000/2800 16ST. - GMT2000 - GMS2000 15ST. - GLS2800/3300 12ST.

MODULO MOTORIZZATO STOZZATORE CORSA 50mm H=85mm

Slotting driven tool 50mm stroke H=85mm

Keilnutenstossmaschine 50mm Hub H=85mm

Subject to change without notice.

M.T. srl

Via Casino Albini 480
 Tel. 0541/956034-957884

Fax 0541/956341

47842 S. GIOVANNI IN M. (RN)

e-mail: mtma@mtmarchetti.com

http://www.mtmarchetti.com

PRODUZIONE MODULI ROTANTI



PAGINA GDW 360-4-00

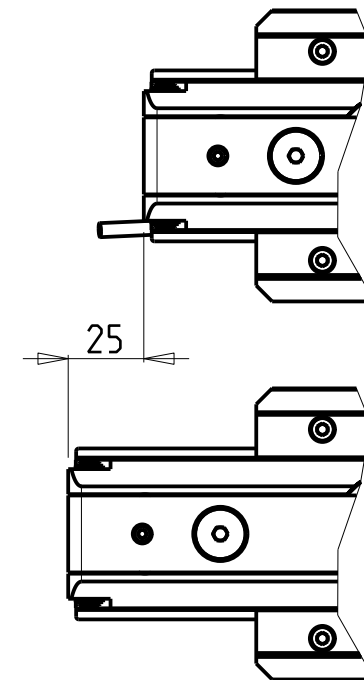
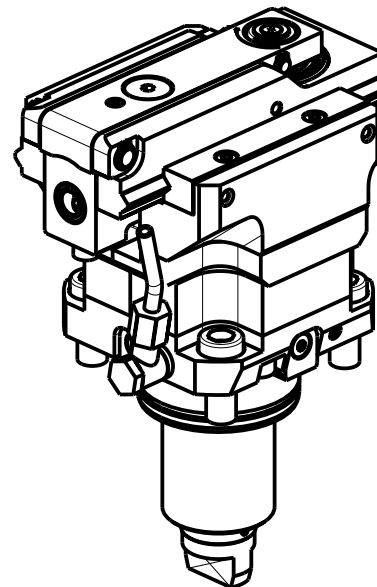
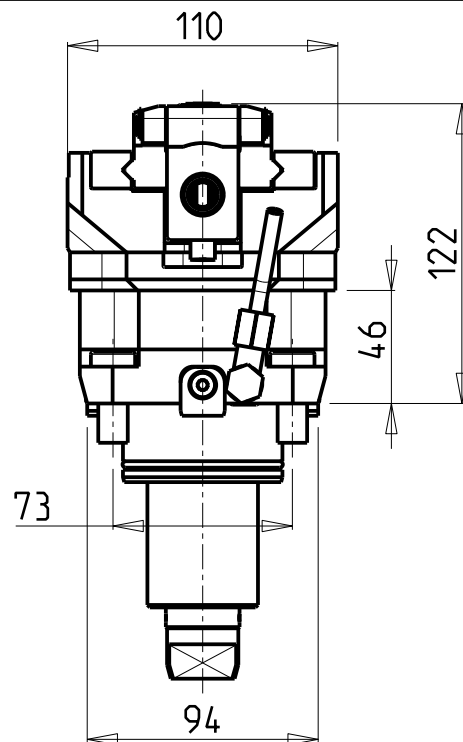
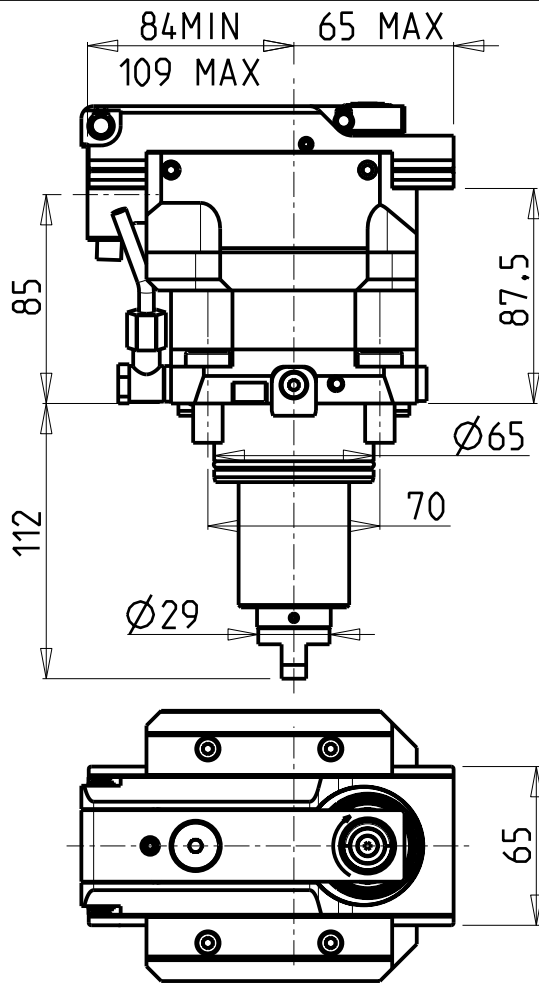

PER UTENSILI STOZZATORI VEDI PAG. TBL400-1-00
 FOR DRIVEN SLOTTING TOOL CUTTING-TOOLS SEE PAGE TBL400-1-00
 FÜR NUTENSTOSS-WERKZEUG SCHNEIDWERKZEUGE SIEHE SEITE TBL400-1-00

Cod. MT	I	RPM MAX	Reversibile lato mandrino/contromandrino Reversible sub/main spindle side Umkehrbare Spindel-seite/ Gegenspindel-seite	Lubr. esterna Ext. coolant Aussenkuehlung
DW01530200	4:1	2400	X	X

GOODWAY

MOD: GTX2000/2600 12ST. - GTZ2000/2600 12ST. - GS2000/2800 16ST. - GMT2000 - GMS2000 15ST. - GLS2800/3300 12ST.

MODULO MOTORIZZATO STOZZATORE CORSA 25mm H=85mm

Slotting driven tool 25mm stroke H=85mm

Keilnutenstossmaschine 25mm Hub H=85mm

Subject to change without notice.

M.T. srl

Via Casino Albini 480
 Tel. 0541/956034-957884
 Fax 0541/956341
 47842 S. GIOVANNI IN M. (RN)
 e-mail: mtma@mtmarchetti.com
 http://www.mtmarchetti.com

PRODUZIONE MODULI ROTANTI



PAGINA GDW 360-4-01

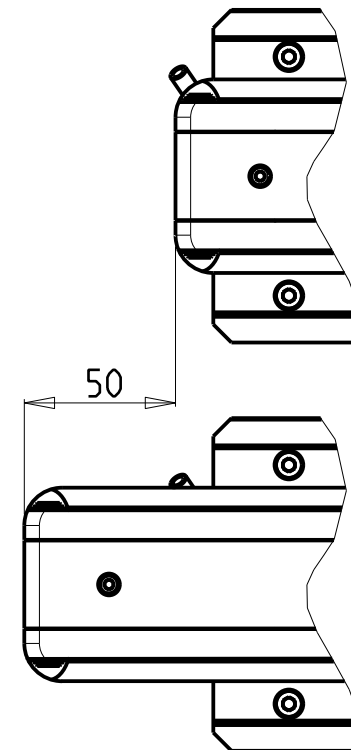
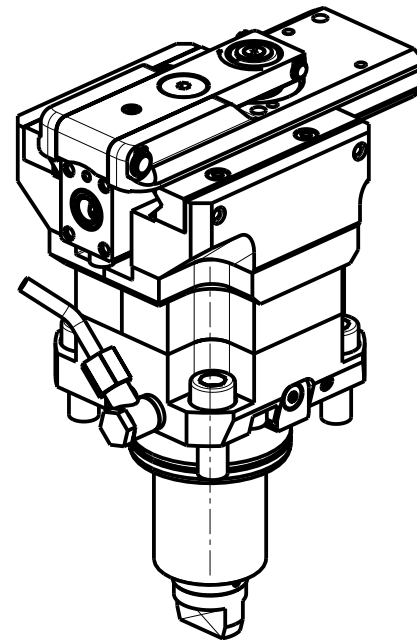
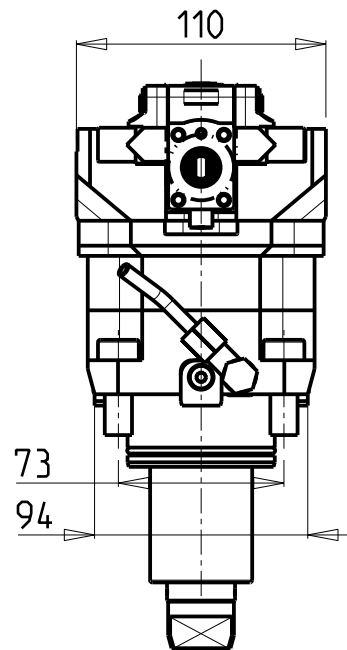
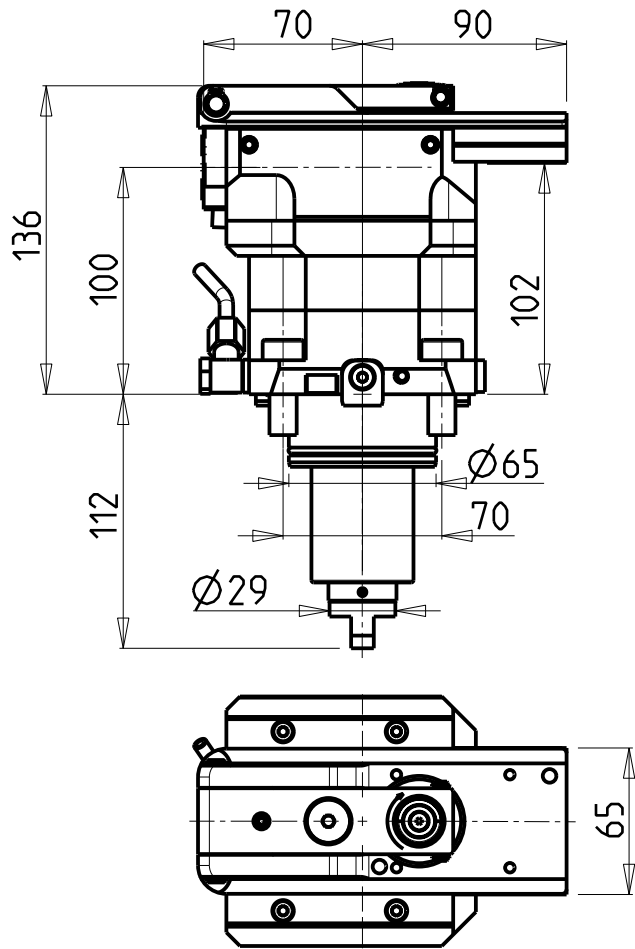

PER UTENSILI STOZZATORI VEDI PAG. TBL400-1-00
 FOR DRIVEN SLOTTING TOOL CUTTING-TOOLS SEE PAGE TBL400-1-00
 FÜR NUTENSTOSS-WERKZEUG SCHNEIDWERKZEUGE SIEHE SEITE TBL400-1-00

Cod. MT	I	RPM MAX	Reversibile lato mandrino/contromandrino Reversible sub/main spindle side Umkehrbare Spindel-seite/ Gegenspindel-seite	Lubr. esterna Ext. coolant Aussenkuehlung
DW 01520100	4:1	2000	X	X

GOODWAY

MOD: GTX2000/2600 12ST. - GTZ2000/2600 12ST. - GS2000/2800 16ST. - GMT2000 - GMS2000 15ST. - GLS2800/3300 12ST.

MODULO MOTORIZZATO STOZZATORE CORSA 50mm H=100mm

Slotting driven tool 50mm stroke H=100mm

Keilnutenstossmaschine 50mm Hub H=100mm

Subject to change without notice.

M.T. srl

Via Casino Albini 480
 Tel. 0541/956034-957884
 Fax 0541/956341
 47842 S. GIOVANNI IN M. (RN)
 e-mail: mtma@mtmarchetti.com
 http://www.mtmarchetti.com

PRODUZIONE MODULI ROTANTI



PAGINA GDW 360-4-10

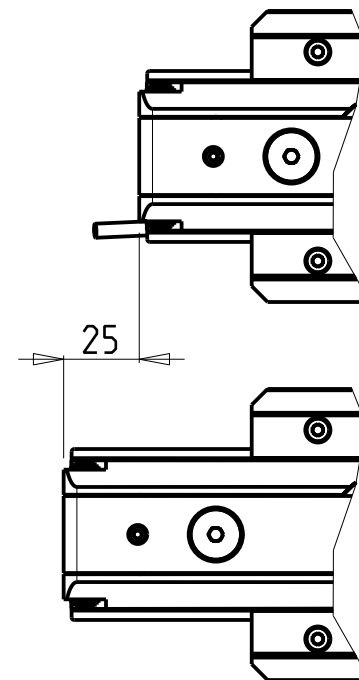
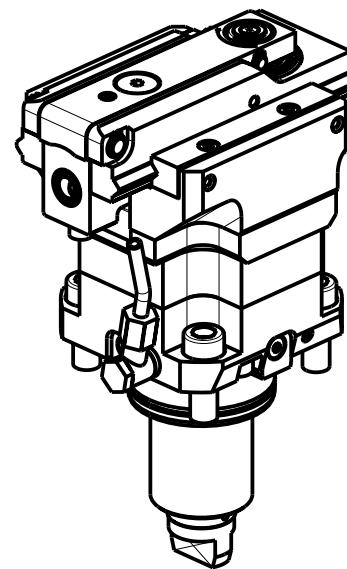
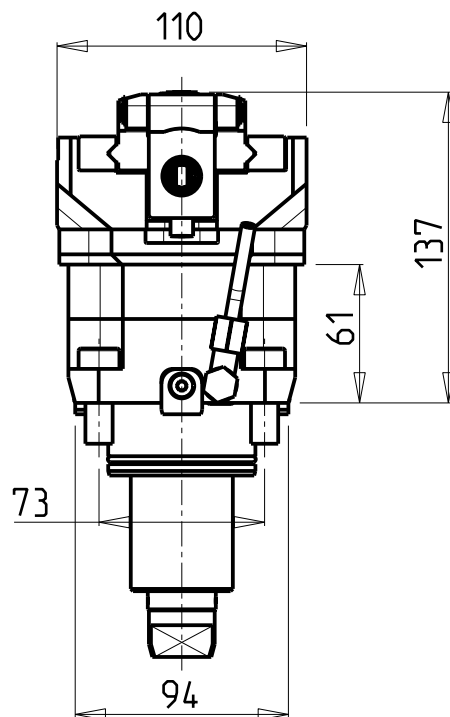
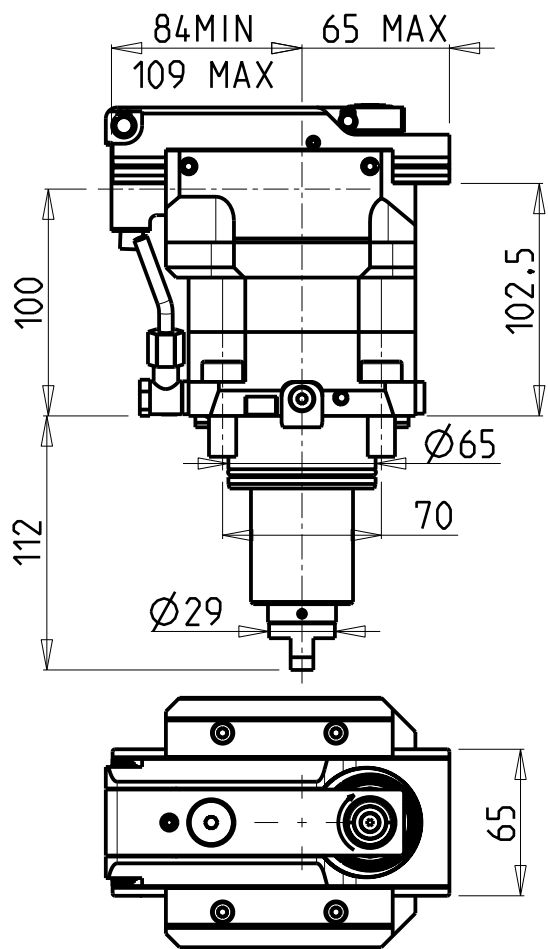

PER UTENSILI STOZZATORI VEDI PAG. TBL400-1-00
 FOR DRIVEN SLOTTING TOOL CUTTING-TOOLS SEE PAGE TBL400-1-00
 FÜR NUTENSTOSS-WERKZEUG SCHNEIDWERKZEUGE SIEHE SEITE TBL400-1-00

Cod. MT	I	RPM MAX	Reversibile lato mandrino/contromandrino Reversible sub/main spindle side Umkehrbare Spindel-seite/ Gegenspindel-seite	Lubr. esterna Ext. coolant Aussenkuehlung
DW 01520200	4:1	2400	X	X

GOODWAY

MOD: GTX2000/2600 12ST. - GTZ2000/2600 12ST. - GS2000/2800 16ST. - GMT2000 - GMS2000 15ST. - GLS2800/3300 12ST.

MODULO MOTORIZZATO STOZZATORE CORSA 25mm H=100mm

Slotting driven tool 25mm stroke H=100mm

Keilnutenstossmaschine 25mm Hub H=100mm

Subject to change without notice.

M.T. srl

Via Casino Albini 480
 Tel. 0541/956034-957884
 Fax 0541/956341
 47842 S. GIOVANNI IN M. (RN)
 e-mail: mtma@mtmarchetti.com
 http://www.mtmarchetti.com

PRODUZIONE MODULI ROTANTI



PAGINA GDW 360-4-11

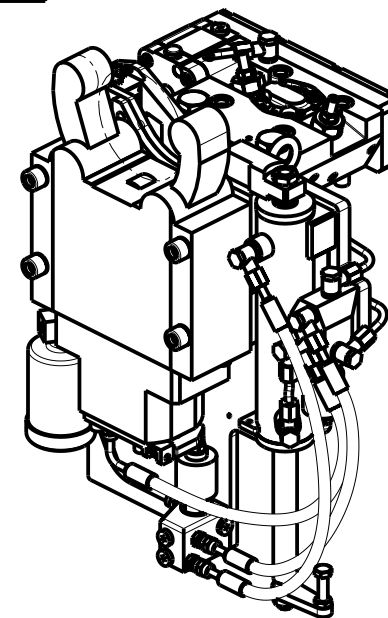
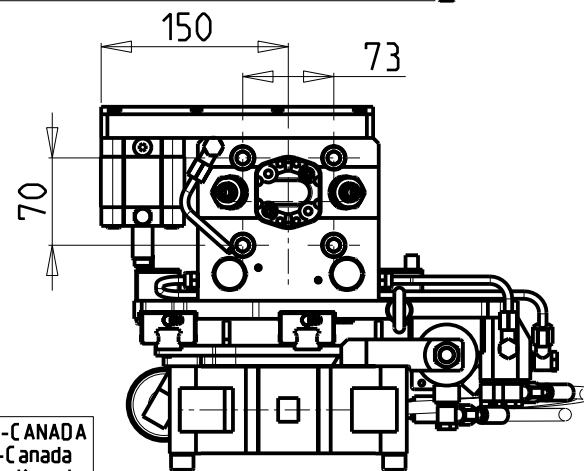
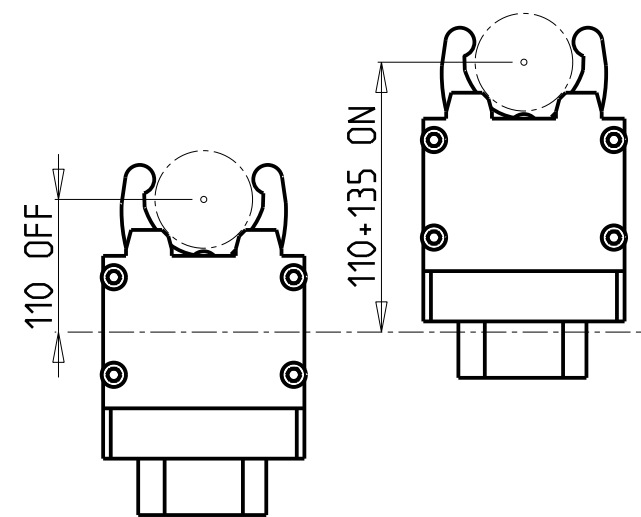
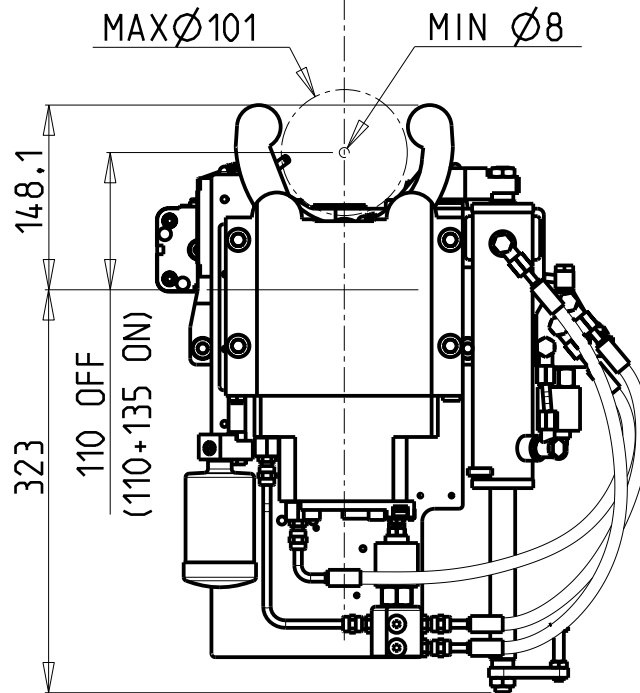
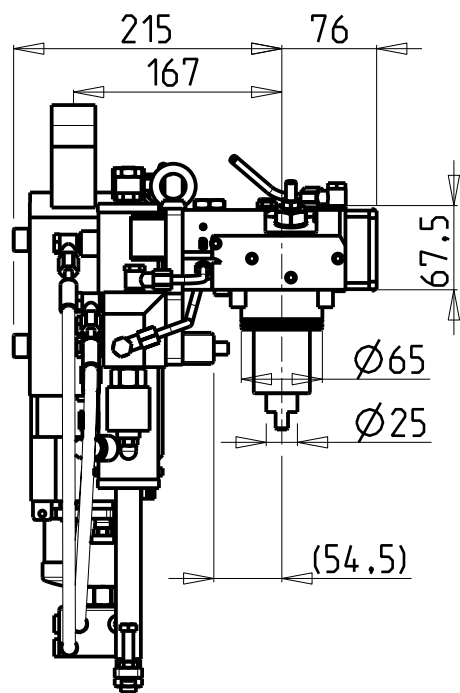

(())	#	CON GESTIONE ELETTRONICA APERTURA COMPLETA DELLA LUNETTA
	#	With Electronic control of steady rest arms complete opening
	#	Mit vollstaendiger elektronischer Oeffnungsbedienung der Luenette

Cod. MT	I	RPM	Lubr. esterna Ext. coolant Aussenkuehlung
DW 00940300	1:1	6000	X
# DW 00940300EU	1:1	6000	X
# DW 00940300US	1:1	6000	X

PER U.S.A.-AUSTRALIA-CANADA
For U.S.A.-Australia-Canada
Fuer U.S.A.-Australien-Kanada

GOODWAY

MOD: GTX2000/2600 12ST. - GTZ2000/2600 12ST. - GMS2000 15ST.

MODULO MOTORIZZATO PER LUNETTA RETRATTILE (TAGLIA 2)

Driven toolholder for sliding steady rest (Size 2)

Luenettenwerkzeug zurueck versetzte Version (Grossse 2)

Subject to change without notice.

M.T. srl

Via Casino Albini 480
Tel. 0541/956034-957884
Fax 0541/956341

47842 S. GIOVANNI IN M. (RN)
e-mail: mtma@mtmarchetti.com
http://www.mtmarchetti.com

PRODUZIONE MODULI ROTANTI



PAGINA GDW 363-4-00

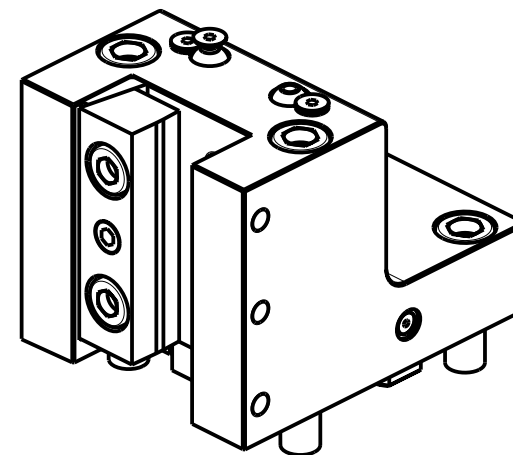
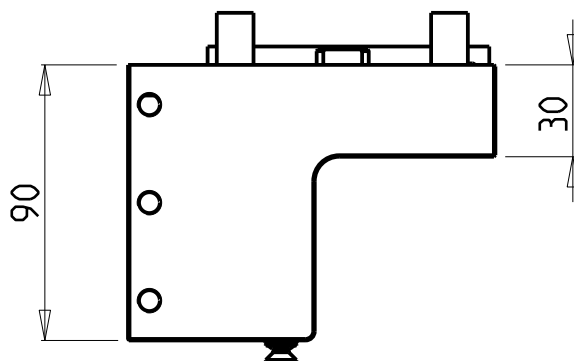
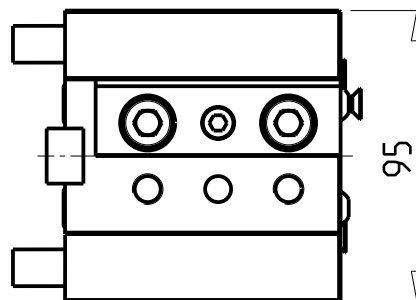
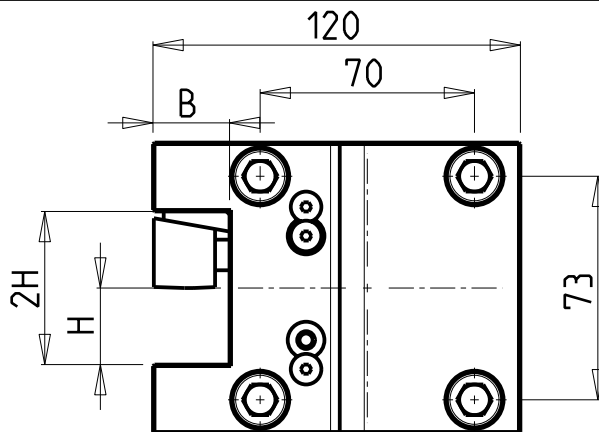

Cod. MT	N°Utensili N°Tools N°Werkzeuge	Reversibile lato mandrino/contromandrino Reversible sub/main spindle side Umkehrbare Spindel-seite/ Gegenspindel-seite	Misure Dimensions Masse	B	H
DW00482500	1	X	mm	25	25
DW00482540	1	X	Inch	1"	1"
DW00482000	1	X	mm	20	20

GOODWAY

MOD: GTX2000/2600 12ST. - GTZ2000/2600 12ST. - GS2000/2800 16ST. - GMT2000 - GMS2000 15ST. - GLS2800/3300 12ST.

PORTAUTENSILE RADIALE SINGOLO QD=25mm / QD=1" / QD=20mm H=90mm

Radial single static tool QD=25mm / QD=1" / QD=20mm H=90mm

Radial Single-Werkzeughalter QD=25mm / QD=1" / QD=20mm H=90mm

Subject to change without notice.

M.T. srl

Via Casino Albini 480
Tel. 0541/956034-957884
Fax 0541/956341
47842 S. GIOVANNI IN M. (RN)
e-mail: mtma@tmarchetti.com
<http://www.tmmarchetti.com>

PRODUZIONE MODULI ROTANTI



PAGINA GDW423-4-00

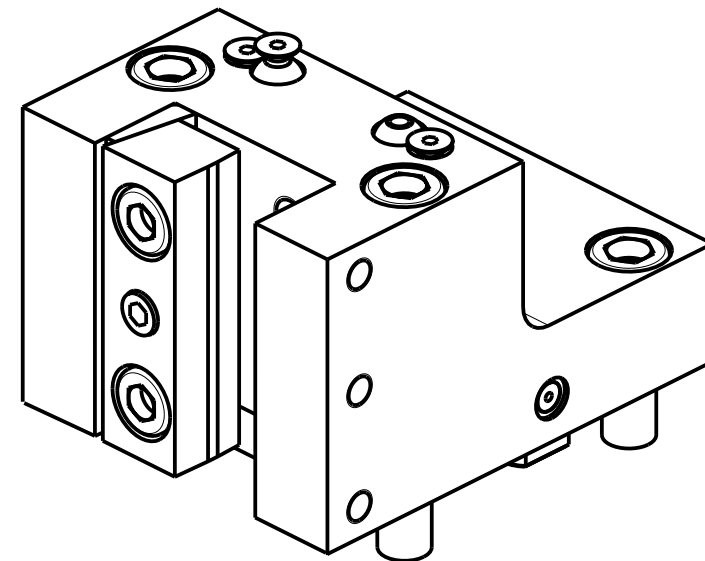
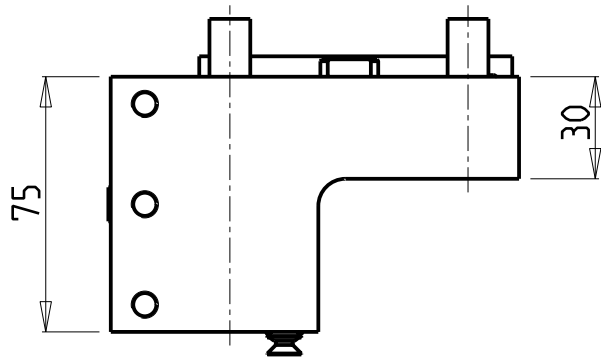
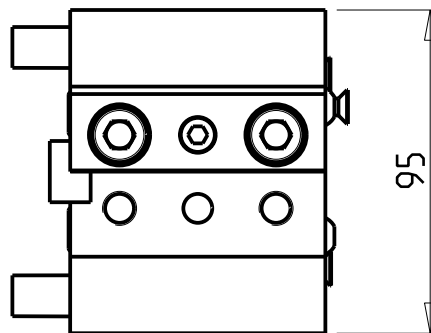
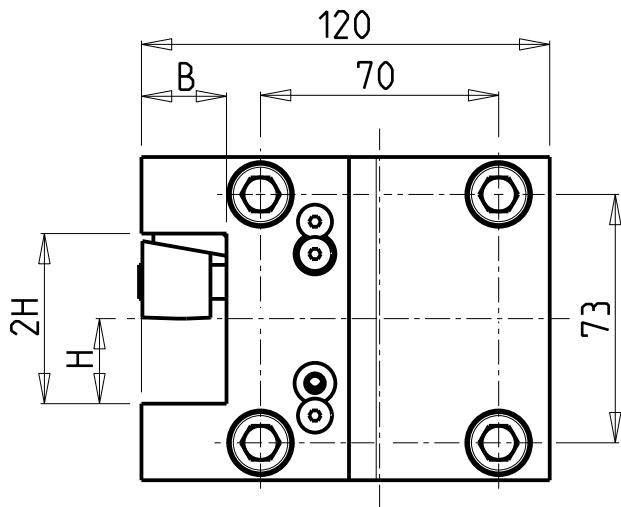

Cod. MT	N°Utensili N°Tools N°Werkzeuge	Reversibile lato mandrino/contromandrino Reversible sub/main spindle side Umkehrbare Spindel-seite/ Gegenspindel-seite	Misure Dimensions Masse	B	H
DW01422500	1	X	mm	25	25
DW01422540	1	X	Inch	1"	1"

GOODWAY

MOD: GTX2000/2600 12ST. - GTZ2000/2600 12ST. - GS2000/2800 16ST. - GMT2000 - GMS2000 15ST. - GLS2800/3300 12ST.

PORTAUTENSILE RADIALE SINGOLO QD=25mm / QD=1" H=75mm

Radial single static tool QD=25mm / QD=1" H=75mm

Radial Single-Werkzeughalter QD=25mm / QD=1" H=75mm

Subject to change without notice.

M.T. srl

Via Casino Albini 480
Tel. 0541/956034-957884
Fax 0541/956341

47842 S. GIOVANNI IN M. (RN)
e-mail: mtma@tmarchetti.com
http://www.mtmarchetti.com

PRODUZIONE MODULI ROTANTI



PAGINA GDW 423-4-10

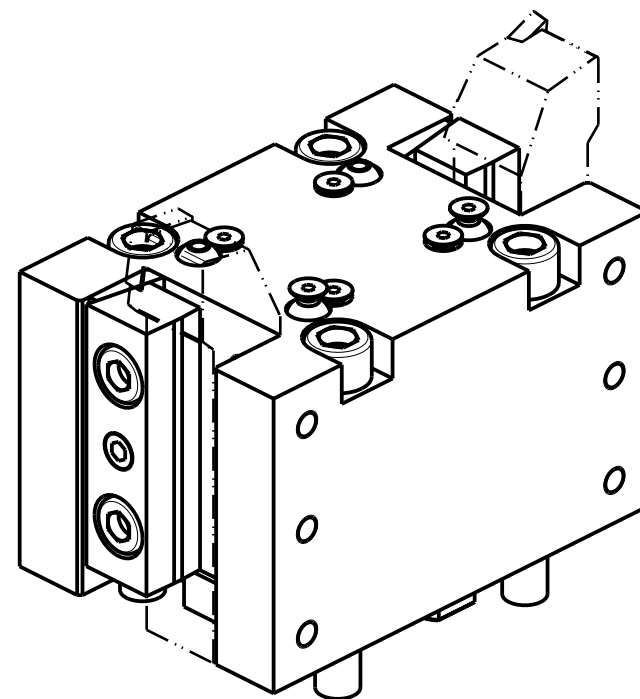
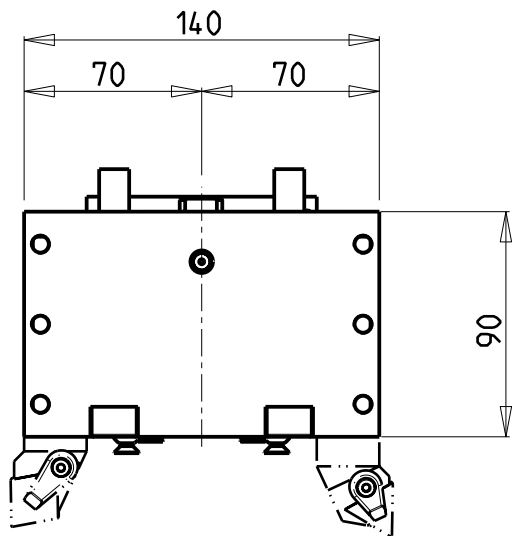
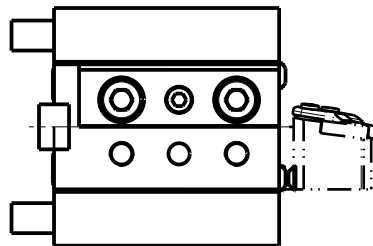
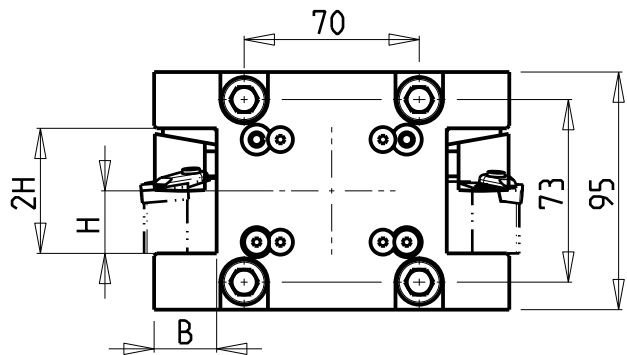

Cod. MT	N°Utensili N°Tools N°Werkzeuge	Reversibile lato mandrino/contromandrino Reversible sub/main spindle side Umkehrbare Spindel-seite/ Gegenspindel-seite	Misure Dimensions Masse	B	H
DW00272500	2/4	X	mm	25	25
DW00272540	2/4	X	Inch	1"	1"
DW00272000	2/4	X	mm	20	20

GOODWAY

MOD: GTX2000/2600 12ST. - GTZ2000/2600 12ST. - GS2000/2800 16ST. - GMT2000 - GMS2000 15ST. - GLS2800/3300 12ST.

PORTAUTENSILE RADIALE DOPPIO QD=25mm / QD=1" / QD=20mm H=90mm

Radial double static tool QD=25mm / QD=1" / QD=20mm H=90mm

Radial Doppel-Werkzeughalter QD=25mm / QD=1" / QD=20mm H=90mm

Subject to change without notice.

M.T. srl

Via Casino Albini 480
Tel. 0541/956034-957884
Fax 0541/956341

47842 S. GIOVANNI IN M. (RN)
e-mail: mtma@mtmarchetti.com
http://www.mtmarchetti.com

PRODUZIONE MODULI ROTANTI



PAGINA GDW453-4-00

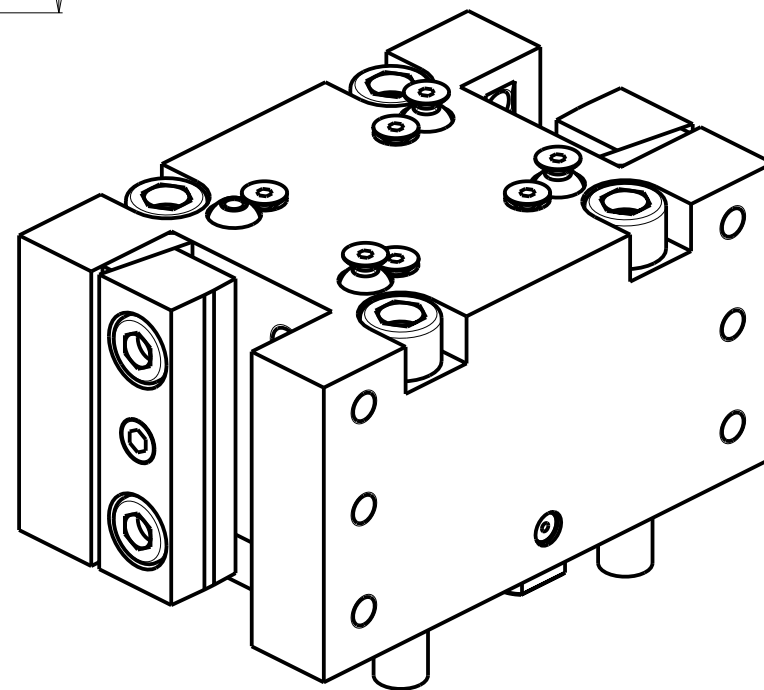
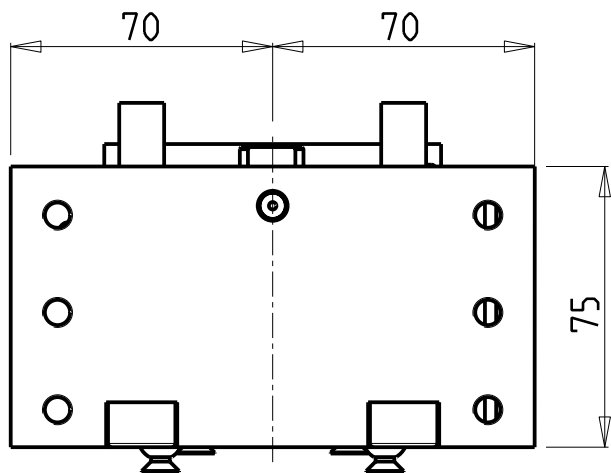
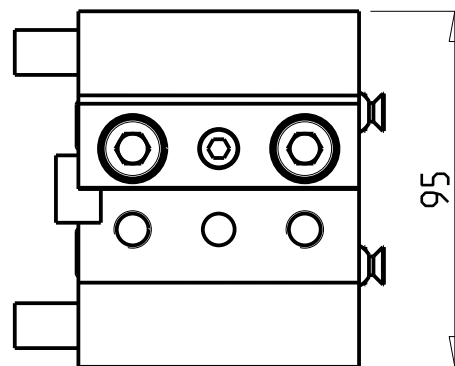
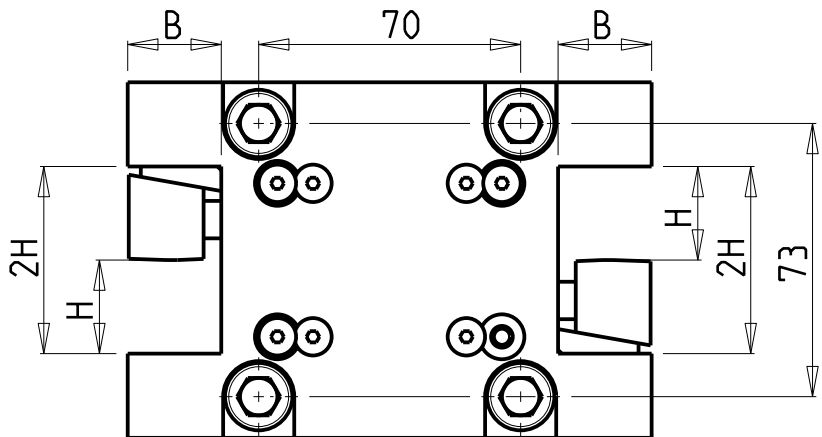

Cod. MT	N°Utensili N°Tools N°Werkzeuge	Reversibile lato mandrino/contromandrino Reversible sub/main spindle side Umkehrbare Spindelseite/ Gegenspindelseite	Misure Dimensions Masse	B	H
DW00672500	2/4	X	mm	25	25
DW00672000	2/4	X	mm	20	20

GOODWAY

MOD: GTX2000/2600 12ST. - GTZ2000/2600 12ST. - GS2000/2800 16ST. - GMT2000 - GMS2000 15ST. - GLS2800/3300 12ST.

PORTAUTENSILE RADIALE DOPPIO QD=25mm / QD=20mm H=75mm

Radial double static tool QD=25mm / QD=20mm H=75mm

Radial Doppel-Werkzeughalter QD=25mm / QD=20mm H=75mm

Subject to change without notice.

M.T. srl

Via Casino Albini 480
Tel. 0541/956034-957884
Fax 0541/956341

47842 S. GIOVANNI IN M. (RN)
e-mail: mtma@mtmarchetti.com
http://www.mtmarchetti.com

PRODUZIONE MODULI ROTANTI



PAGINA GDW453-4-10

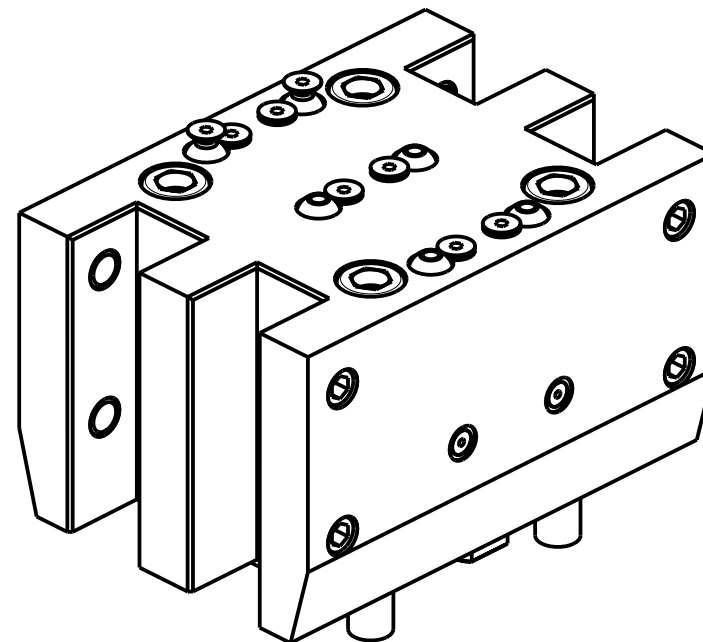
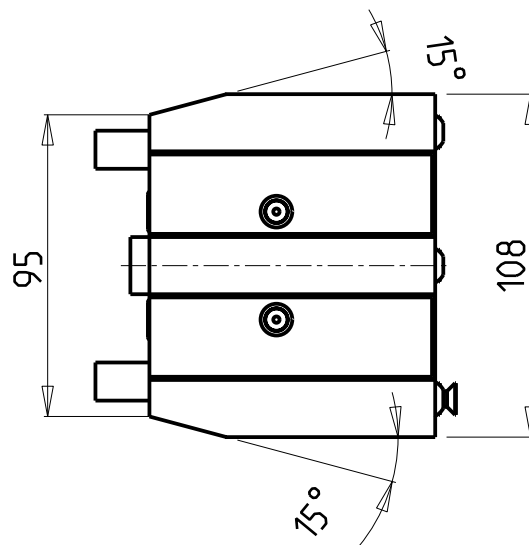
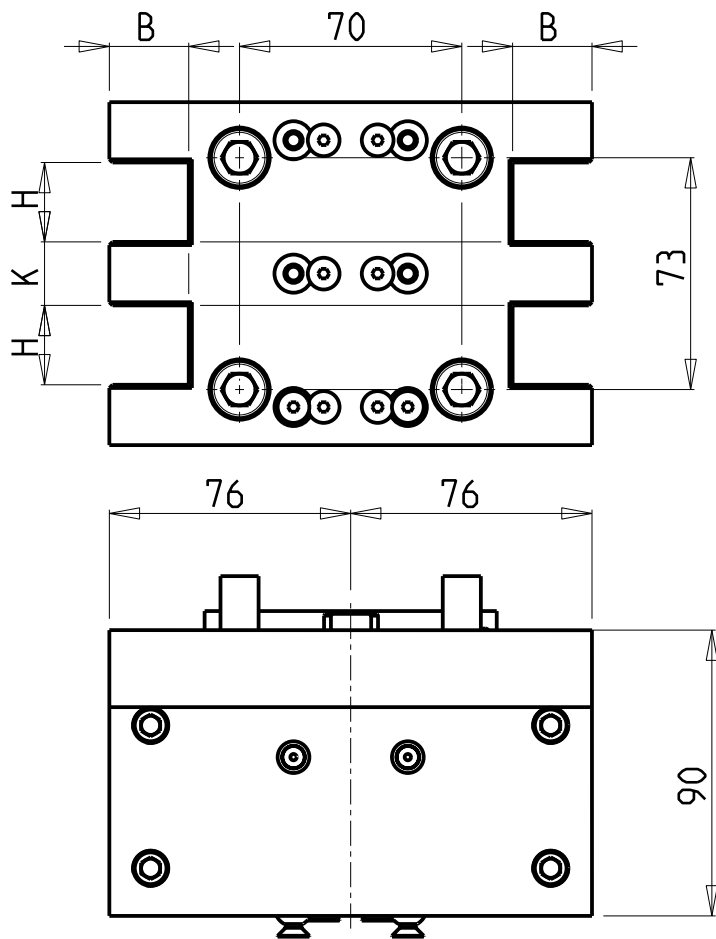

Cod. MT	N°Utensili N° Tools N° Werkzeuge	Reversibile lato mandrino/contromandrino Reversible sub/main spindle side Umkehrbare Spindel-seite/ Gegenspindel-seite	Misure Dimensions Masse	H	K	B
DW00622500	4	X	mm	25	20	25
DW00622540	4	X	inch	1"	3/4"	1"

GOODWAY

MOD: GTX2000/2600 12ST. - GTZ2000/2600 12ST. - GS2000/2800 16ST. - GMT2000 - GLS2800/3300 12ST.

PORTAUTENSILE RADIALE DOPPIO SOVRAPPOSTO QD=25mm / QD=1"

Radial double side twin static tool QD=25mm / QD=1"

Radial Doppel-Werkzeughalter ueberlagert QD=25mm / QD=1"

Subject to change without notice.

M.T. srl

Via Casino Albini 480
Tel. 0541/956034-957884
Fax 0541/956341

47842 S. GIOVANNI IN M. (RN)
e-mail: mtma@tmarchetti.com
http://www.mtmarchetti.com

PRODUZIONE MODULI ROTANTI



PAGINA GDW463-4-00

10/2018

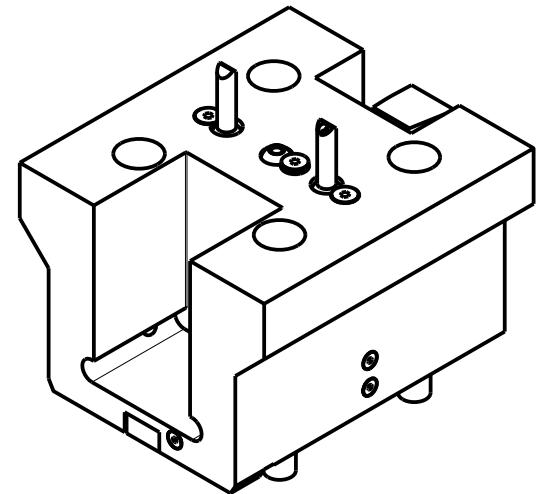
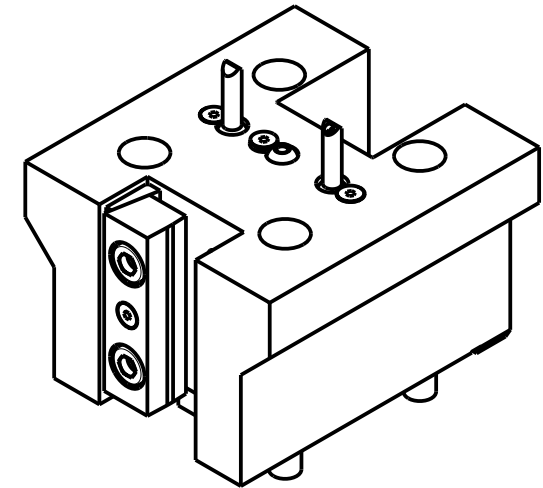
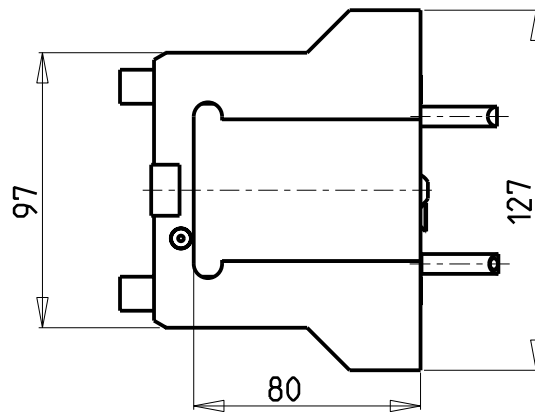
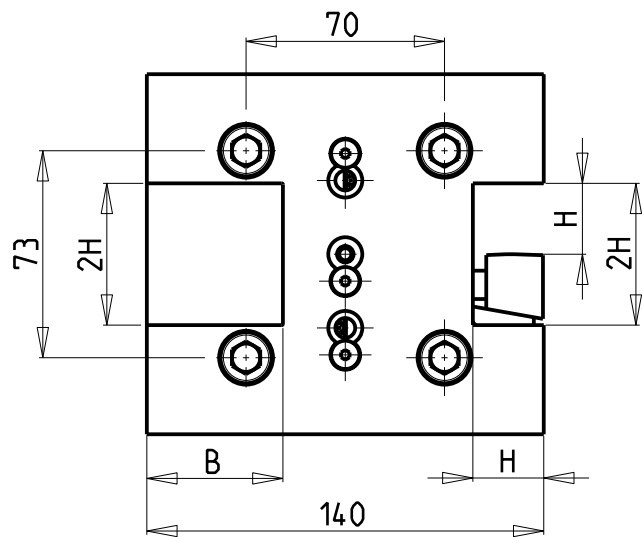
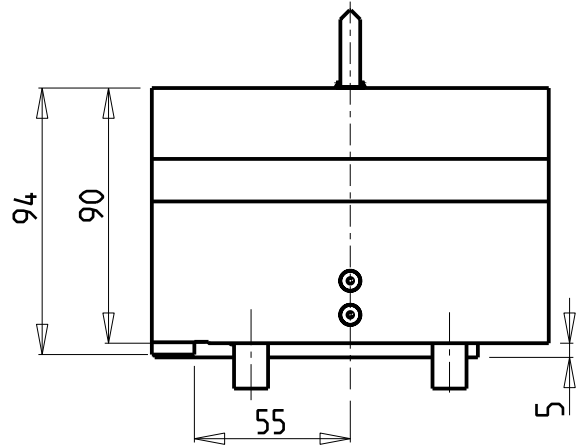

Cod. MT	N°Utensili N°Tools N°Werkzeuge	Reversibile lato mandrino/contromandrino Reversible sub/main spindle side Umkehrbare Spindel-seite/ Gegenspindel-seite	Misure Dimensions Masse	H	B
0875000	2	X	mm	25	48

GOODWAY

MOD: GTX2000/2600 12ST. - GTZ2000/2600 12ST. - GS2000/2800 16ST. - GMT2000 - GMS2000 15ST. - GLS2800/3300 12ST.

PORTAUTENSILE RADIALE DOPPIO QD=25mm CON SEDE ATTACCO MT CAPTO

Radial double static tool QD=25mm with seat for MT CAPTO connection

Radial Doppel-Werkzeughalter QD=25mm mit Sitz fuer MT CAPTO Anschluss

Subject to change without notice.

M.T. srl

Via Casino Albini 480

Tel. 0541/956034-957884

Fax 0541/956341

47842 S. GIOVANNI IN M. (RN)

e-mail: mtma@mtmarchetti.com

http://www.mtmarchetti.com

PRODUZIONE MODULI ROTANTI



PAGINA GDW 495-4-00

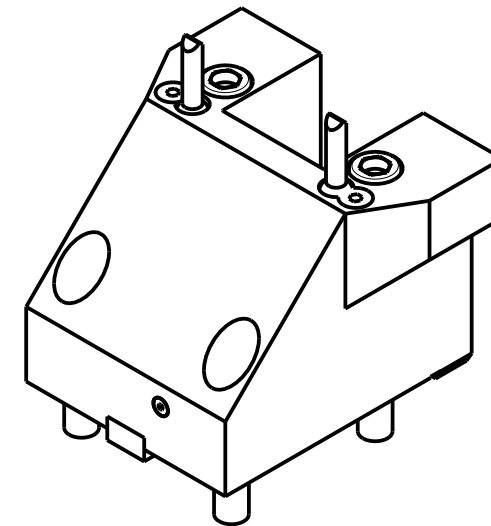
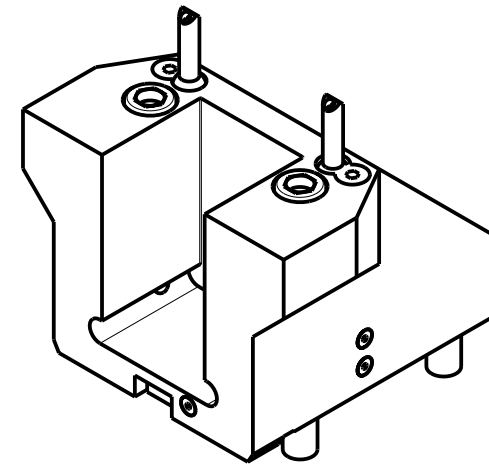
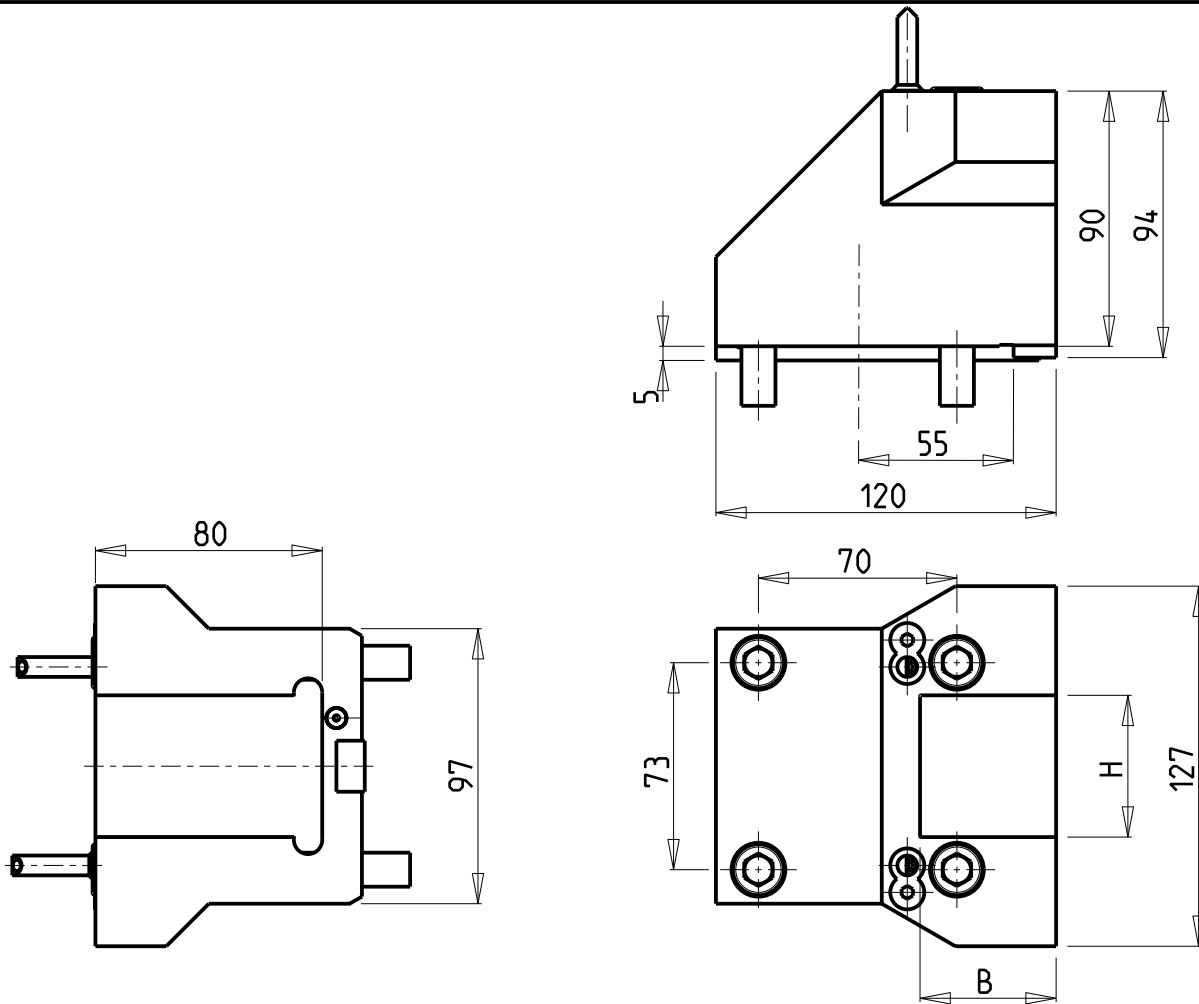

Cod. MT	N°Utensili N°Tools N°Werkzeuge	Reversibile lato mandrino/contromandrino Reversible sub/main spindle side Umkehrbare Spindel-seite/ Gegenspindel-seite	Misure Dimensions Masse	H	B
0885000	1	X	mm	50	48

GOODWAY

MOD: GTX2000/2600 12ST. - GTZ2000/2600 12ST. - GS2000/2800 16ST. - GMT2000 - GMS2000 15ST. - GLS2800/3300 12ST.

PORTAUTENSILE RADIALE CON SEDE ATTACCO MT CAPTO

Radial tool with seat for MT CAPTO connection

Radial Single-Werkzeughalter mit Sitz fuer MT CAPTO Anschluss

Subject to change without notice.

M.T. srl

Via Casino Albini 480
Tel. 0541/956034-957884
Fax 0541/956341
47842 S. GIOVANNI IN M. (RN)
e-mail: mtma@mtmarchetti.com
http://www.mtmarchetti.com

PRODUZIONE MODULI ROTANTI



PAGINA GDW500-4-00

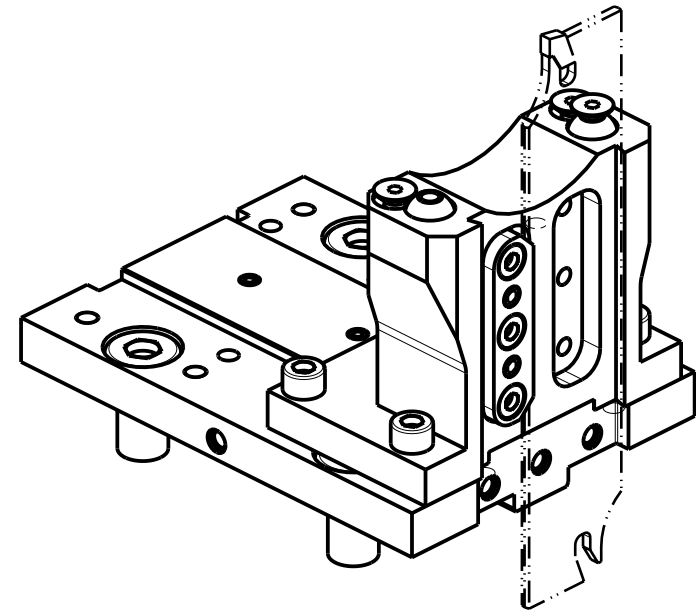
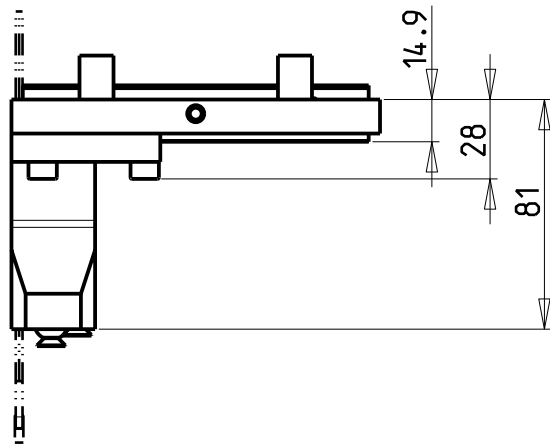
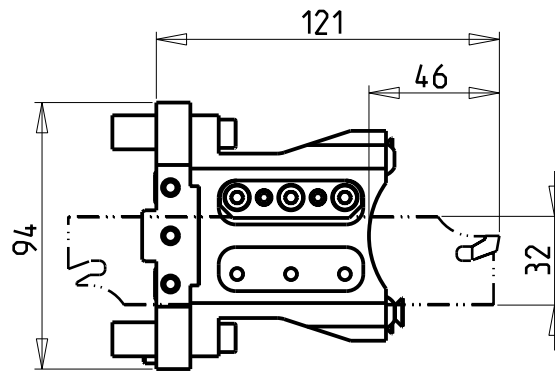
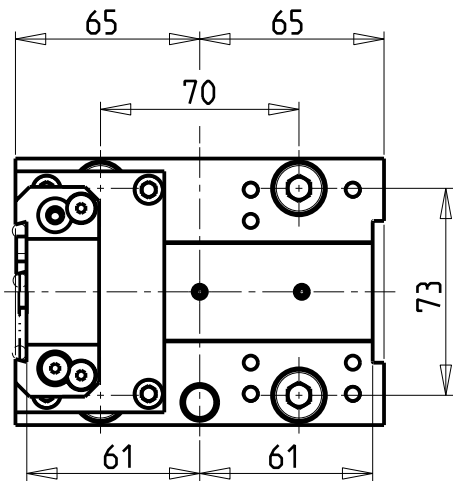

POSSIBILITA' DI LAVORO M3/M4
 OPTION OF M3/M4 WORKING
 ARBEITSMÖGLICHKEIT M3/M4

DOTAZIONI - SUPPLIED WITH - AUSSTATTUNG

N°1 - LAMA - BLADE - KLINGE ISCAR H=32 Sp. 3/4mm
 (KENNAMETAL OPTIONAL)

N°10 - INSERTI - INSERTS - EINLAGEN

N°1 - CHIAVE A T PER MONTAGGIO INSERTI
 - T-WRENCH FOR INSERT SET UP
 - T-SCHLUESSEL FUER EINSATZSTUECK-MONTAGE

Cod. MT	N°Utensili N°Tools N°Werkzeuge	Reversibile lato mandrino/contromandrino Reversible sub/main spindle side Umkehrbare Spindel-seite/ Gegenspindel-seite	Lubr.esterna Ext. coolant Aussenkuehlung
DW01410132	1	X	X

GOODWAY

MOD: GTX2000/2600 12ST. - GTZ2000/2600 12ST. - GS2000/2800 16ST. - GMT2000 - GMS2000 15ST. - GLS2800/3300 12ST.

PORTAUTENSILE RADIALE PER LAMA

Radial blade holder

Radial Abstechhalter

Subject to change without notice.

M.T. srl

Via Casino Albini 480
 Tel. 0541/956034-957884
 Fax 0541/956341
 47842 S. GIOVANNI IN M. (RN)
 e-mail: mtma@mtmarchetti.com
 http://www.mtmarchetti.com

PRODUZIONE MODULI ROTANTI



PAGINA GDW520-4-01

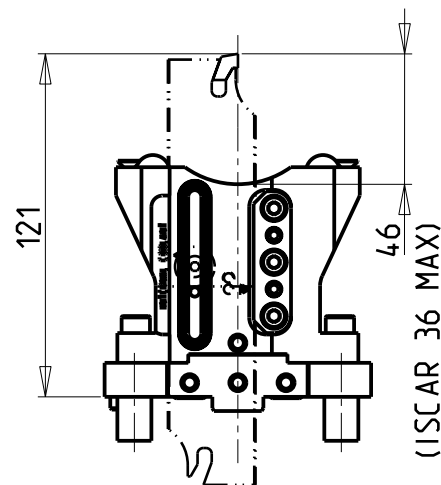
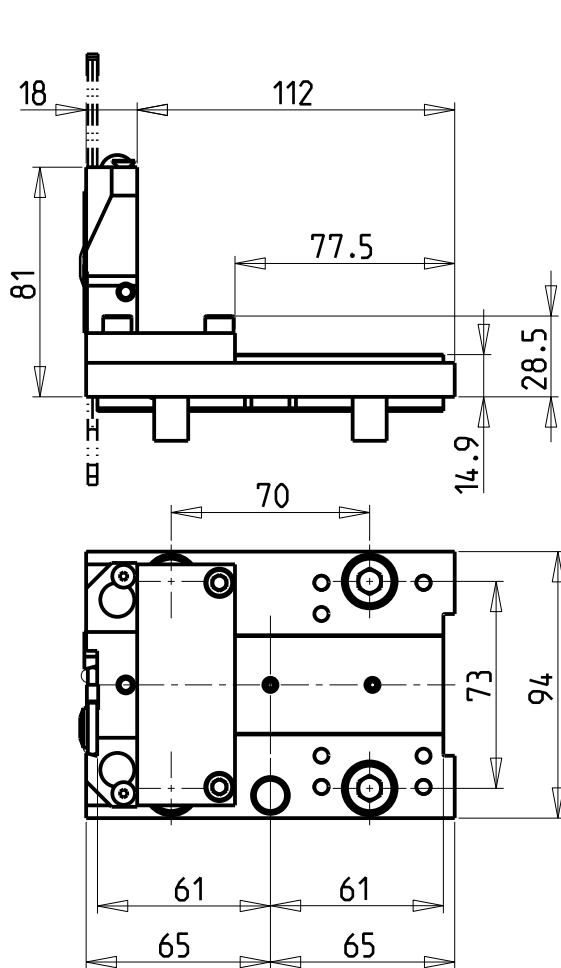

versione dx
right version
version rechts

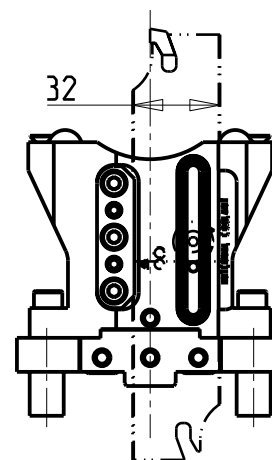

versione sx
left version
version links

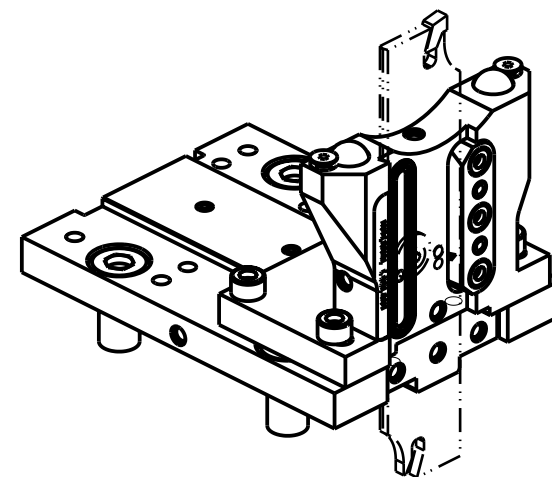

**KIT LAME NON INCLUSI (OPZIONALI)
BLADES NOT SUPPLIED WITH (OPTIONAL)
KLINGEN NICHT INBEGRIFFEN (OPTIONAL)**

- LAMA-BLADE-KLINGE SANDVIK H=32 sp.3 cod. QD_NN2G60C25A
+INSERTI-INSERTS-EINLAGEN cod. QD_NG_0300_0002_CM_1145 (10 pz.)
- LAMA-BLADE-KLINGE SANDVIK H=32 sp.4 cod. QD_NN2H60C25A
+INSERTI-INSERTS-EINLAGEN cod. QD_NH_0400_0002_CM_1145 (10 pz.)
- LAMA-BLADE-KLINGE ISCAR H=32 sp.3 cod. SGFH_32K_3
+INSERTI-INSERTS-EINLAGEN cod. 6011365 (10pz.)
- LAMA-BLADE-KLINGE ISCAR H=32 sp.4 cod. SGFH_32K_4
+INSERTI-INSERTS-EINLAGEN cod. 6011366 (10pz.)
- LAMA-BLADE-KLINGE WALTER H=32 sp.3 cod. G2042.32N-3T45SX-P
+INSERTI-INSERTS-EINLAGEN cod. SX-3E300N02-CE4 WSM33S (10pz.) + CHIAVE-KEY cod. FS1494
- LAMA-BLADE-KLINGE WALTER H=32 sp.4 cod. G2042.32N-4T50SX-P
+INSERTI-INSERTS-EINLAGEN cod. SX-4E400N02-CE4 WSM33S (10pz.) + CHIAVE-KEY cod. FS1494

Cod. MT		N°Utensili N°Tools N°Werkzeuge	Reversibile lato mandrino/contromandrino Reversible sub/main spindle side Umkehrbare Spindel-seite/ Gegenspindel-seite	Lubr.esterna Ext. coolant Aussenkuehlung	Lubr.interna Coolant through Innenkuehlung
versione dx right version version rechts	versione sx left version version links				
DW 01730132R	DW 01730132L	1	X	X	P=70bar

GOODWAY

MOD: GTX2000/2600 12ST. - GTZ2000/2600 12ST. - GS2000/2800 16ST. - GMT2000 - GMS2000 15ST. - GLS2800/3300 12ST.

PORTAUTENSILE RADIALE PER LAMA CON LUBRIFICAZIONE INTERNA

Radial blade holder with internal coolant

Radial Abstechhalter mit Innenkuehlung

Subject to change without notice.

M.T. srl

Via Casino Albini 480
Tel. 0541/956034-957884
Fax 0541/956341
47842 S. GIOVANNI IN M. (RN)
e-mail: mtma@mtmarchetti.com
http://www.mtmarchetti.com

PRODUZIONE MODULI ROTANTI



PAGINA GDW520-4-05

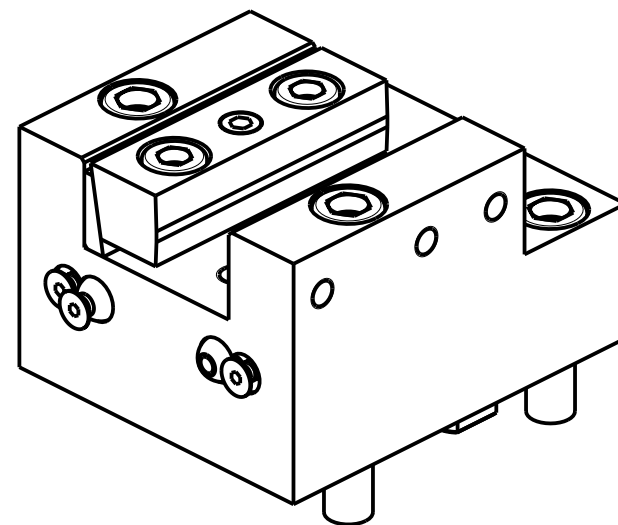
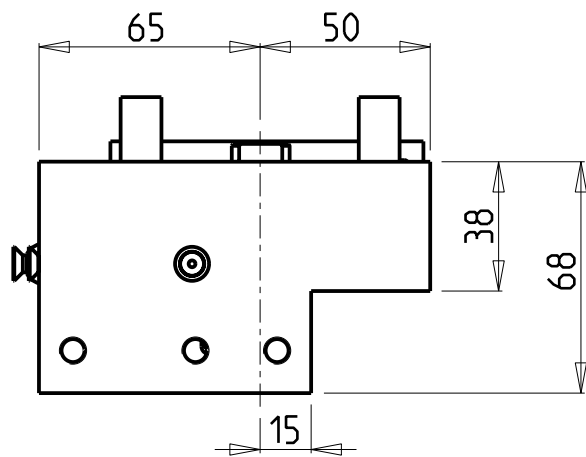
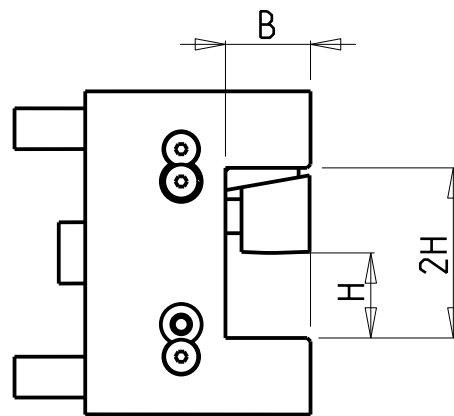
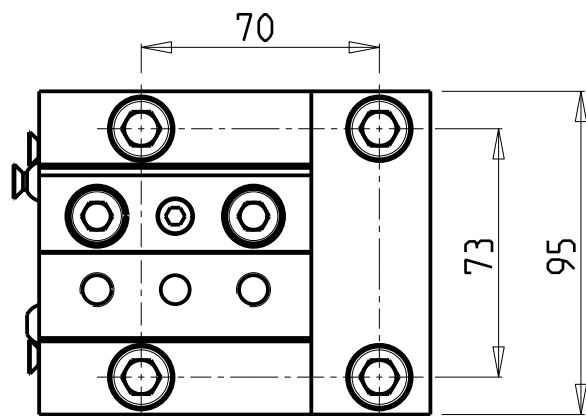

Cod. MT	N°Utensili N°Tools N°Werkzeuge	Reversibile lato mandrino/contromandrino Reversible sub/main spindle side Umkehrbare Spindel-seite/ Gegenspindel-seite	Misure Dimensions Masse	B	H
DW01452500	1	X	mm	25	25
DW01452540	1	X	Inch	1"	1"

GOODWAY

MOD: GTX2000/2600 12ST. - GTZ2000/2600 12ST. - GS2000/2800 16ST. - GMT2000 - GMS2000 15ST. - GLS2800/3300 12ST.

PORTAUTENSILE ASSIALE SINGOLO QD=25mm / QD=1"

Axial single static tool QD=25mm / QD=1"

Axial Single-Werkzeughalter QD=25mm / QD=1"

Subject to change without notice.

M.T. srl

Via Casino Albini 480
Tel. 0541/956034-957884
Fax 0541/956341

47842 S. GIOVANNI IN M. (RN)
e-mail: mtma@mtmarchetti.com
<http://www.mtmarchetti.com>

PRODUZIONE MODULI ROTANTI



PAGINA GDW552-4-00

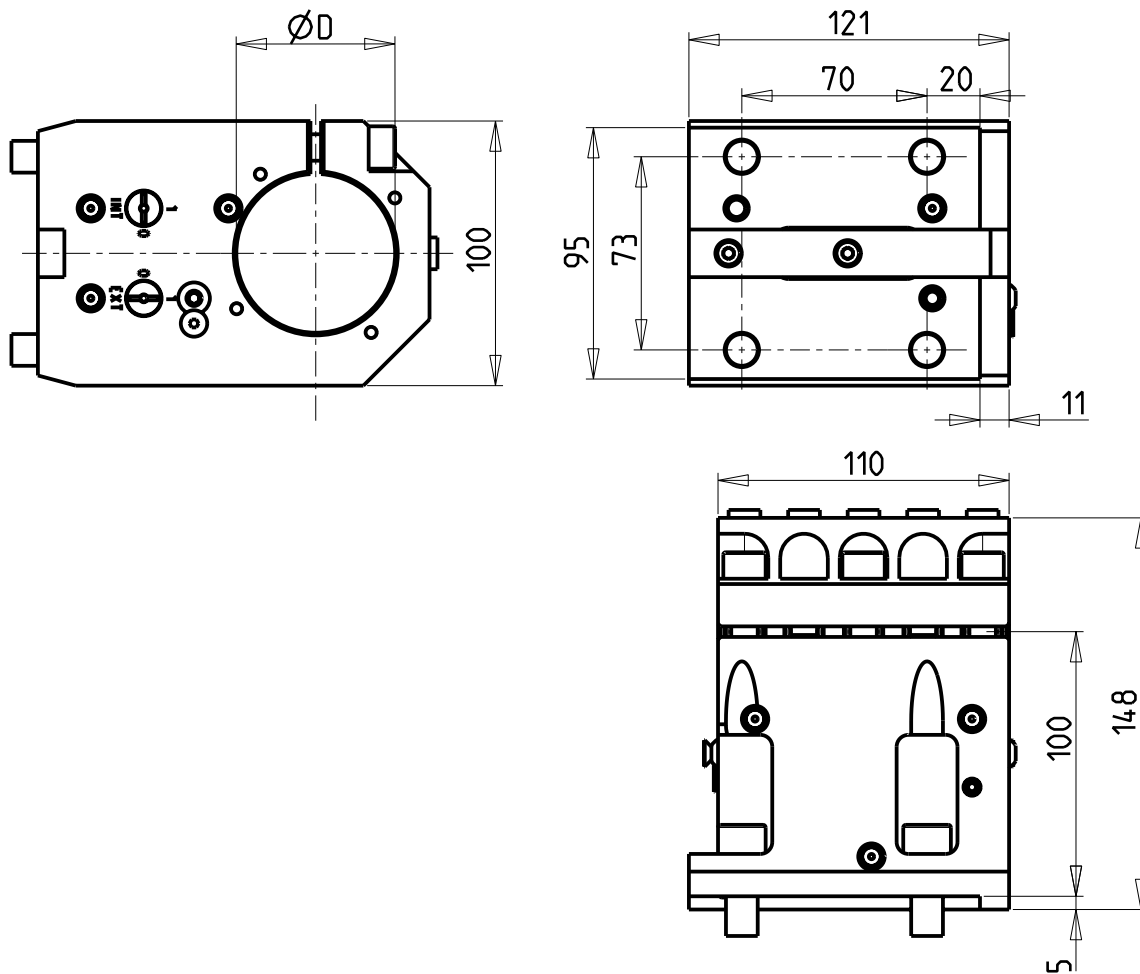

KIT ADDUZIONE INTERNA (OPZIONALE)
 KIT FOR INTERNAL COOLANT (OPTIONAL)
 KIT FUER INTERNE KUEHLMITTELZUFUHR (OPTIONAL)
 Ø60 cod. KIT1003025

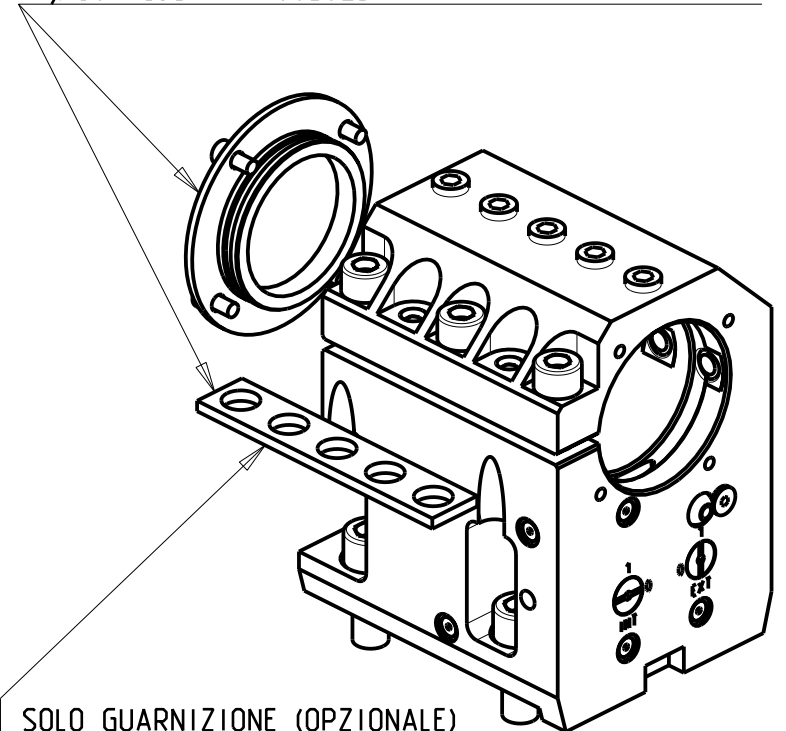

SOLO GUARNIZIONE (OPZIONALE)
 ONLY SEAL (OPTIONAL) NUR
 DICHTUNG (OPTIONAL) cod.
 0520013

PER BOCCOLE DI RIDUZIONE VEDI PAG. TBL150-1-00
 FOR REDUCING BUSHINGS SEE PAGE TBL150-1-00
 FUR REDUZIERBUCHSE SIEHE SEITE TBL150-1-00

Cod. MT	N°Utensili N°Tools N°Werkzeuge	Reversibile lato mandrino/contromandrino Reversible sub/main spindle side Umkehrbare Spindel-seite/ Gegenspindel-seite	Lubrificazione int. opzionale Coolant through optional Innenkuehlung Optional	Lubrificazione est. Ext. coolant Aussenkuehlung	Misure Dimensions Masse	D
DW00746000	1	X	X	X	mm	60

GOODWAY
 MOD: GTX2000/2600 12ST. - GTZ2000/2600 12ST. - GS2000/2800 16ST. - GMT2000 - GMS2000 15ST. - GLS2800/3300 12ST.

PORTAUTENSILE ASSIALE PER BARENO Ø60mm H=100mm
 Axial single boring bar holder Ø60mm H=100mm
 Axial Bohrhalter Ø60mm H=100mm

Subject to change without notice.

M.T. srl
 Via Casino Albini 480
 Tel. 0541/956034-957884
 Fax 0541/956341
 47842 S. GIOVANNI IN M. (RN)
 e-mail: mtma@mtmarchetti.com
 http://www.mtmarchetti.com

PRODUZIONE MODULI ROTANTI

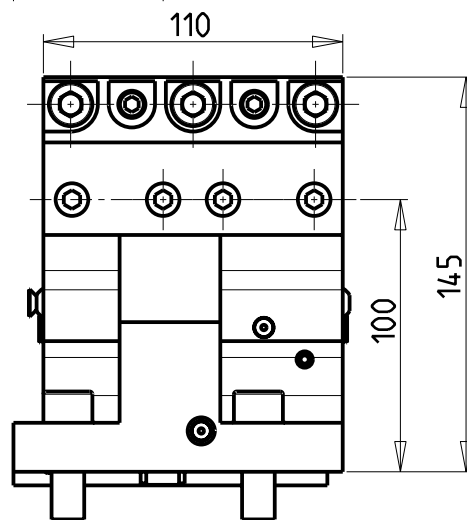
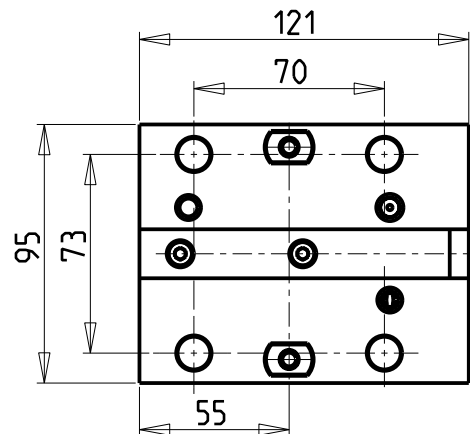
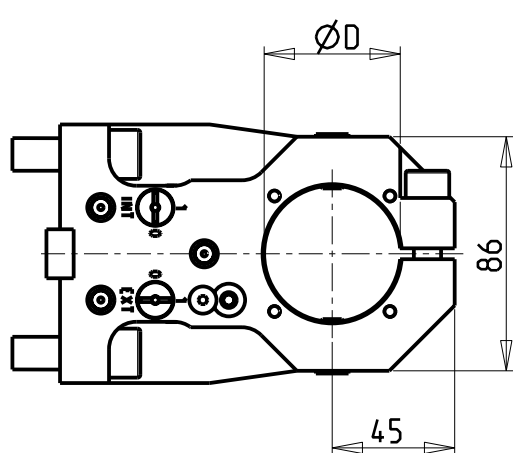
 PAGINA GDW590-4-20

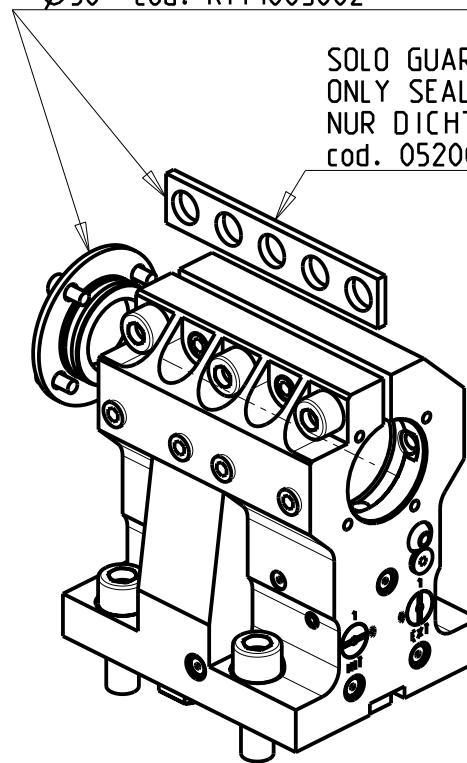

KIT ADDUZIONE INTERNA (OPZIONALE)
 KIT FOR INTERNAL COOLANT (OPTIONAL)
 KIT FÜR INTERNE KUEHLMITTELZUFUHR (OPTIONAL)
 Ø50 cod. KIT1003002

SOLO GUARNIZIONE (OPZIONALE)
 ONLY SEAL (OPTIONAL)
 NUR DICHTUNG (OPTIONAL)
 cod. 0520013



PER BOCCOLE DI RIDUZIONE VEDI PAG. TBL150-1-00
 FOR REDUCING BUSHINGS SEE PAGE TBL150-1-00
 FÜR REDUZIERBUCHSE SIEHE SEITE TBL150-1-00

Cod. MT	N°Utensili N°Tools N°Werkzeuge	Reversibile lato mandrino/contromandrino Reversible sub/main spindle side Umkehrbare Spindel-seite/ Gegenspindel-seite	Lubrificazione int. opzionale Coolant through optional Innenkuehlung Optional	Lubrificazione est. Ext. coolant Aussenkuehlung	Misure Dimensions Masse	D
DW00205000	1	X	X	X	mm	50

GOODWAY

MOD: GTX2000/2600 12ST. - GTZ2000/2600 12ST. - GS2000/2800 16ST. - GMT2000 - GMS2000 15ST. - GLS2800/3300 12ST.

PORTAUTENSILE ASSIALE PER BARENO Ø50mm H=100mm

Axial single boring bar holder Ø50mm H=100mm

Axial Bohrhälter Ø50mm H=100mm

Subject to change without notice.

M.T. srl

Via Casino Albini 480
 Tel. 0541/956034-957884
 Fax 0541/956341

47842 S. GIOVANNI IN M. (RN)
 e-mail: mtma@mtmarchetti.com
 http://www.mtmarchetti.com

PRODUZIONE MODULI ROTANTI



PAGINA GDW620-4-20

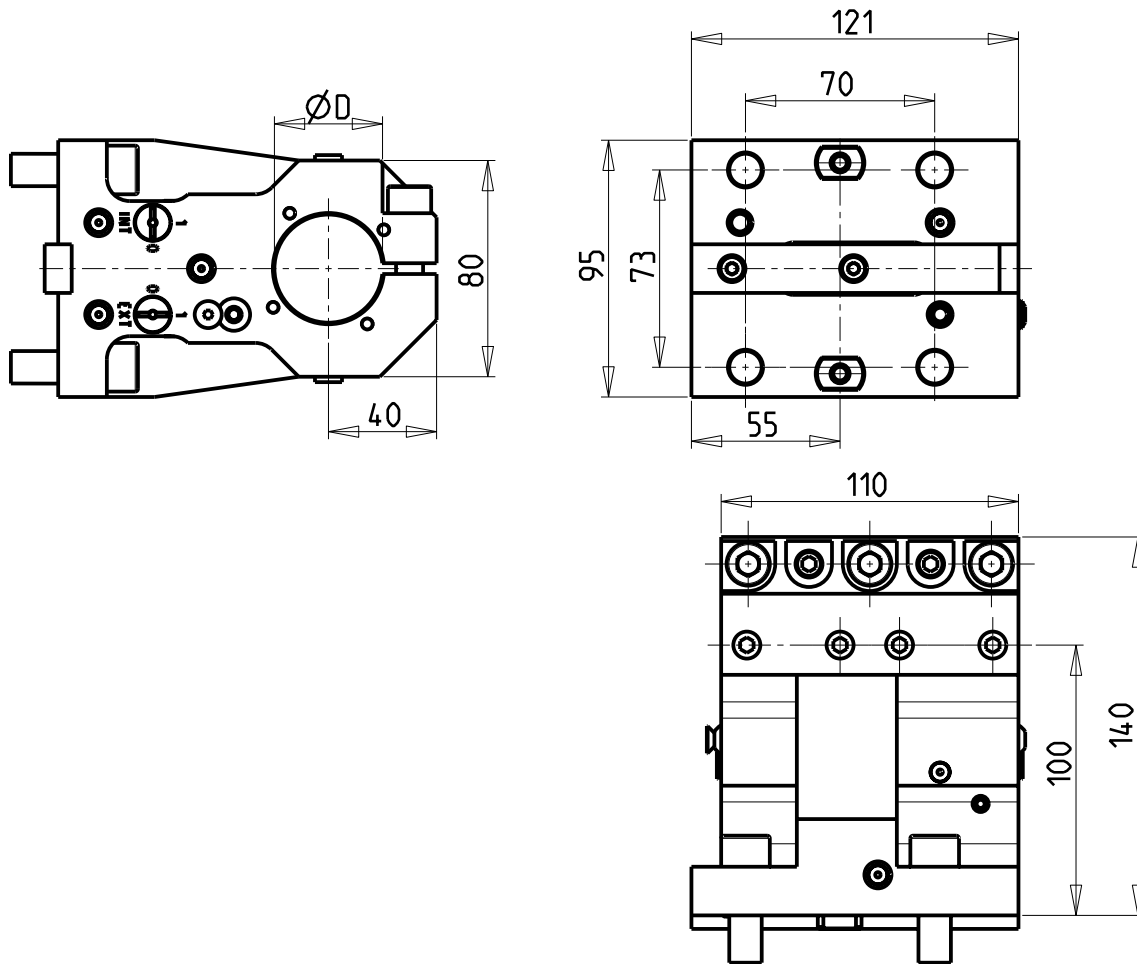

KIT ADDUZIONE INTERNA (OPZIONALE)
 KIT FOR INTERNAL COOLANT (OPTIONAL)
 KIT FUER INTERNE KUEHLMITTELZUFUHR (OPTIONAL)
 Ø40 cod. KIT1003003

SOLO GUARNIZIONE (OPZIONALE)
 ONLY SEAL (OPTIONAL)
 NUR DICHTUNG (OPTIONAL)
 cod. 0520013

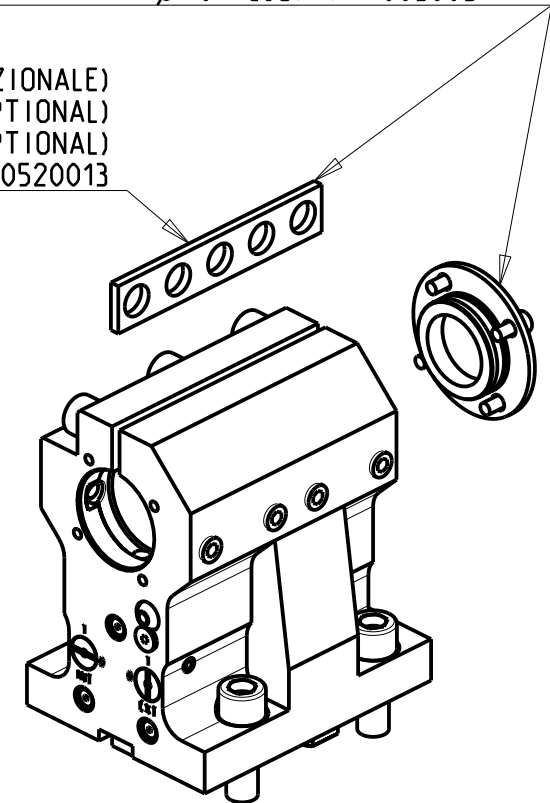

PER BOCCOLE DI RIDUZIONE VEDI PAG. TBL150-1-00
 FOR REDUCING BUSHINGS SEE PAGE TBL150-1-00
 FUR REDUZIERBUCHSE SIEHE SEITE TBL150-1-00

Cod. MT	N°Utensili N°Tools N°Werkzeuge	Reversibile lato mandrino/contromandrino Reversible sub/main spindle side Umkehrbare Spindel-seite/ Gegenspindel-seite	Lubrificazione int. opzionale Coolant through optional Innenkuehlung Optional	Lubrificazione est. Ext. coolant Aussenkuehlung	Misure Dimensions Masse	D
DW00204000	1	X	X	X	mm	40

GOODWAY

MOD: GTX2000/2600 12ST. - GTZ2000/2600 12ST. - GS2000/2800 16ST. - GMT2000 - GMS2000 15ST. - GLS2800/3300 12ST.

PORTAUTENSILE ASSIALE PER BARENO Ø40mm H=100mm

Axial single boring bar holder Ø40mm H=100mm

Axial Bohrhälter Ø40mm H=100mm

Subject to change without notice.

M.T. srl

Via Casino Albini 480
 Tel. 0541/956034-957884
 Fax 0541/956341
 47842 S. GIOVANNI IN M. (RN)
 e-mail: mtma@mtmarchetti.com
 http://www.mtmarchetti.com

PRODUZIONE MODULI ROTANTI



PAGINA GDW 640-4-20

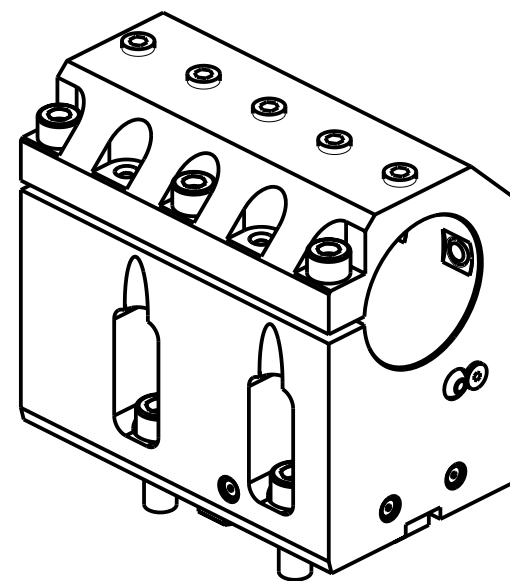
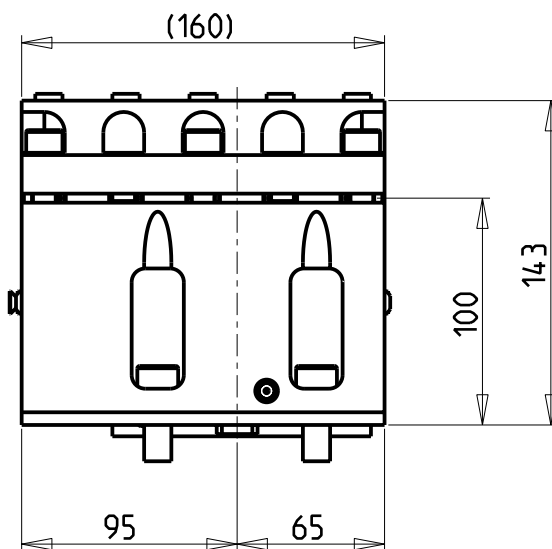
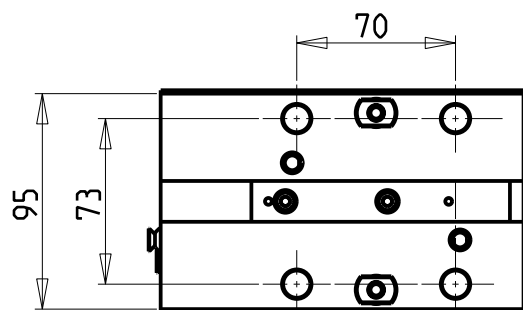
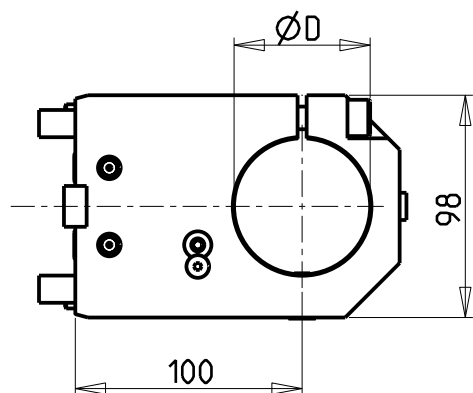

PER BOCCOLE DI RIDUZIONE VEDI PAG. TBL150-1-00
 FOR REDUCING BUSHINGS SEE PAGE TBL150-1-00
 FÜR REDUZIERBUCHSE SIEHE SEITE TBL150-1-00

Cod. MT	N°Utensili N°Tools N°Werkzeuge	Reversibile lato mandrino/contromandrino Reversible sub/main spindle side Umkehrbare Spindel-seite/ Gegenspindel-seite	Lubrificazione est. Ext. coolant Aussenkuehlung	Misure Dimensions Masse	D
DW01446000	1	X	X	mm	60

GOODWAY

MOD: GTX2000/2600 12ST. - GTZ2000/2600 12ST. - GS2000/2800 16ST. - GMT2000 - GMS2000 15ST. - GLS2800/3300 12ST.

PORTAUTENSILE ASSIALE PER BARENO Ø60mm H=100mm

Axial single boring bar holder Ø60mm H=100mm

Axial Bohrhälter Ø60mm H=100mm

Subject to change without notice.

M.T. srl

Via Casino Albini 480
 Tel. 0541/956034-957884
 Fax 0541/956341

47842 S. GIOVANNI IN M. (RN)
 e-mail: mtma@mtmarchetti.com
 http://www.mtmarchetti.com

PRODUZIONE MODULI ROTANTI



PAGINA GDW720-4-20

KIT ADDUZIONE INTERNA (OPZIONALE)
 KIT FOR INTERNAL COOLANT (OPTIONAL)
 KIT FUER INTERNE KUEHLMITTELZUFUHR (OPTIONAL)
 cod. KIT1000001

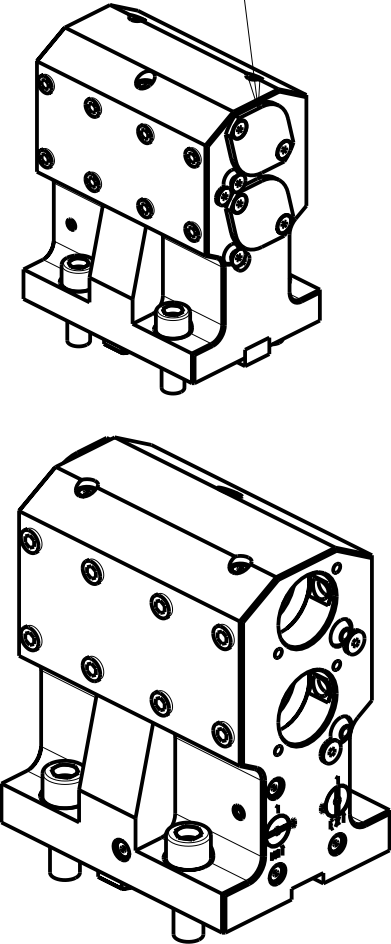
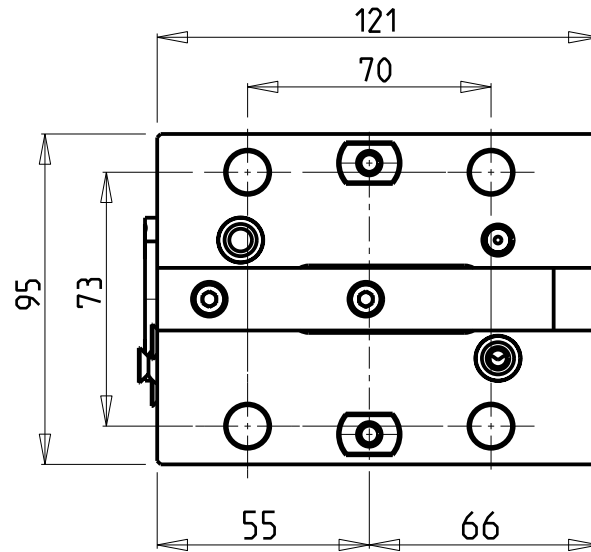
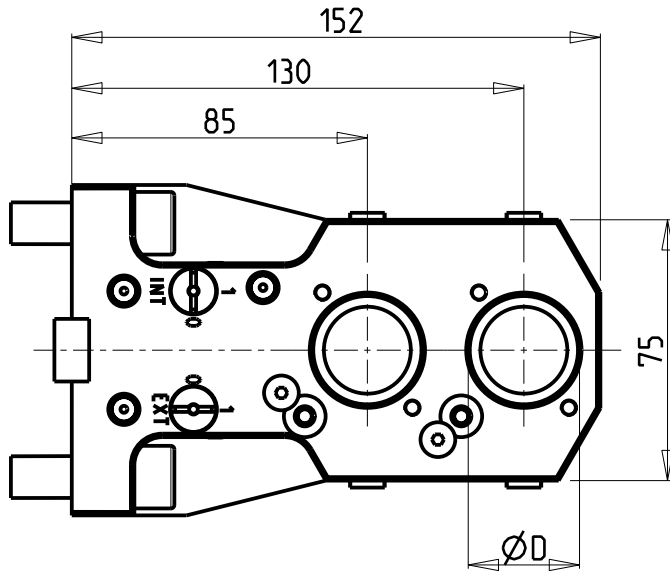

PER BOCCOLE DI RIDUZIONE VEDI PAG. TBL150-1-00
 FOR REDUCING BUSHINGS SEE PAGE TBL150-1-00
 FÜR REDUZIERBUCHSE SIEHE SEITE TBL150-1-00

Cod. MT	N°Utensili N°Tools N°Werkzeuge	Reversibile lato mandrino/contromandrino Reversible sub/main spindle side Umkehrbare Spindel-seite/ Gegenspindel-seite	Lubrificazione int. opzionale Coolant through optional Innenkuehlung Optional	Lubrificazione est. Ext. coolant Aussehenkuehlung	Misure Dimensions Masse	D
DW00213200	2+2	X	X	X	mm	32
DW00213175	2+2	X	X	X	Inch	1 1/4"

GOODWAY

MOD: GTX2000/2600 12ST. - GTZ2000/2600 12ST. - GS2000/2800 16ST. - GMT2000 - GMS2000 15ST. - GLS2800/3300 12ST.

PORTAUTENSILE ASSIALE PER BARENO 2 POSIZIONI Ø32mm / Ø1 1/4"

Axial double boring bar holder Ø32mm / Ø1 1/4"

Axial Bohrhälter 2 Positionen Ø32mm / Ø1 1/4"

Subject to change without notice.

M.T. srl

Via Casino Albini 480
 Tel. 0541/956034-957884
 Fax 0541/956341
 47842 S. GIOVANNI IN M. (RN)
 e-mail: mtma@mtmarchetti.com
 http://www.mtmarchetti.com

PRODUZIONE MODULI ROTANTI



PAGINA GDW862-4-00

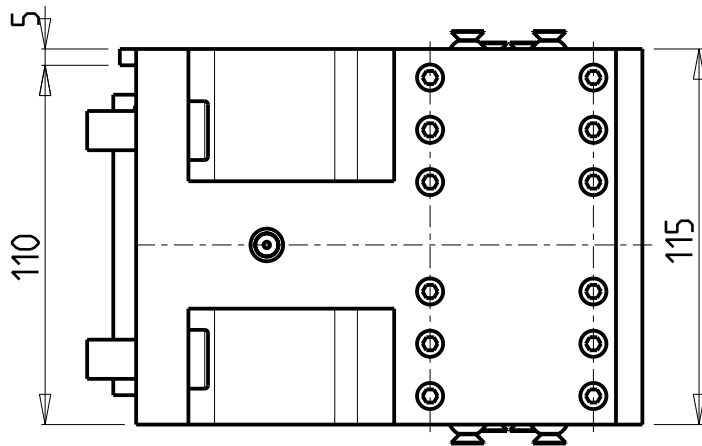
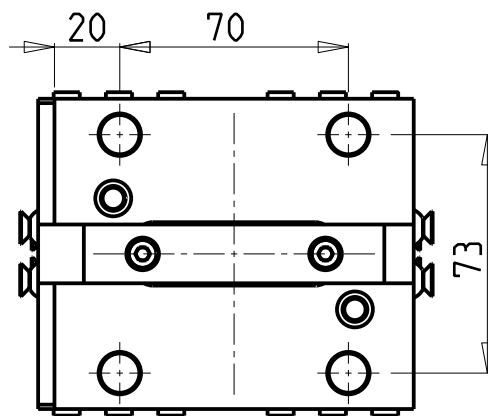
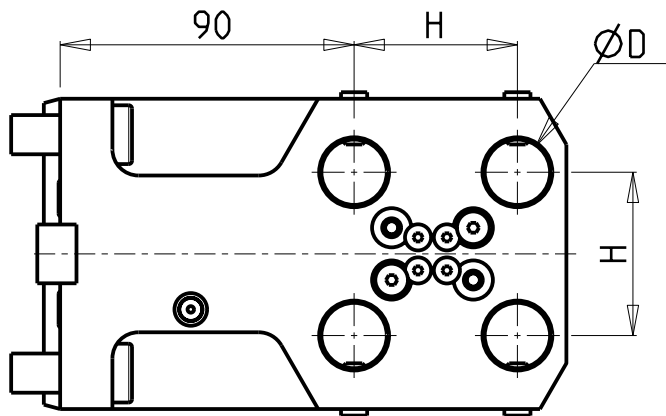

DOTAZIONI - SUPPLIED WITH - AUSSTATTUNG

mm	N°5 Boccole - Bushings - Buchsen Ø16-12-10-8-6 N°1 ER16 Portapinza - Collet holder - Zangenhalter N°1 ER25 Portapinza - Collet holder - Zangenhalter
inch	N°3 Boccole - Bushings - Buchsen Ø1/2"-3/8"-1/4" N°1 ER16 Portapinza - Collet holder - Zangenhalter N°1 ER25 Portapinza - Collet holder - Zangenhalter

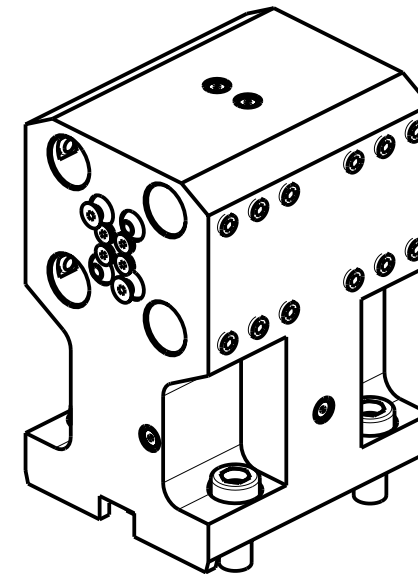

Cod. MT	N°Utensili N°Tools N°Werkzeuge	Reversibile lato mandrino/contromandrino Reversible sub/main spindle side Umkehrbare Spindel-seite/ Gegenspindel-seite	Lubrificazione est. Ext. coolant Aussenkuehlung	Misure Dimensions Masse	D	H
DW 00632000	4+4	X	X	mm	20	50
DW 00631905	4+4	X	X	Inch	3/4"	2"

GOODWAY

MOD: GTX2000/2600 12ST. - GTZ2000/2600 12ST. - GS2000/2800 16ST. - GMT2000 - GLS2800/3300 12ST.

PORTAUTENSILE ASSIALE PER BARENO 4+4 POSIZIONI Ø20mm/Ø3/4"

Axial 4+4 position boring bar holder Ø20mm/Ø3/4"

Axial Bohrhälter 4+4 Positionen Ø20mm/Ø3/4"

Subject to change without notice.

M.T. srl

Via Casino Albini 480
Tel. 0541/956034-957884
Fax 0541/956341
47842 S. GIOVANNI IN M. (RN)
e-mail: mtma@mtmarchetti.com
http://www.mtmarchetti.com

PRODUZIONE MODULI ROTANTI



PAGINA GDW 924-4-00

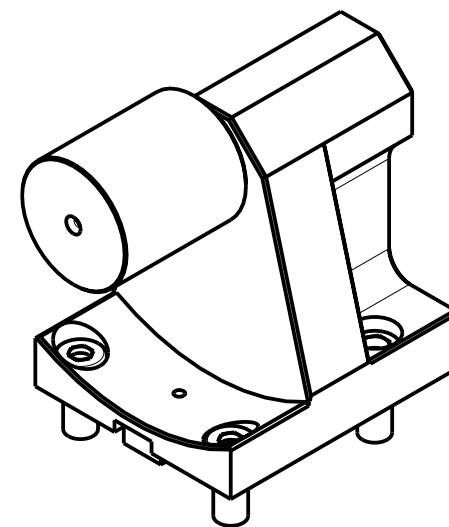
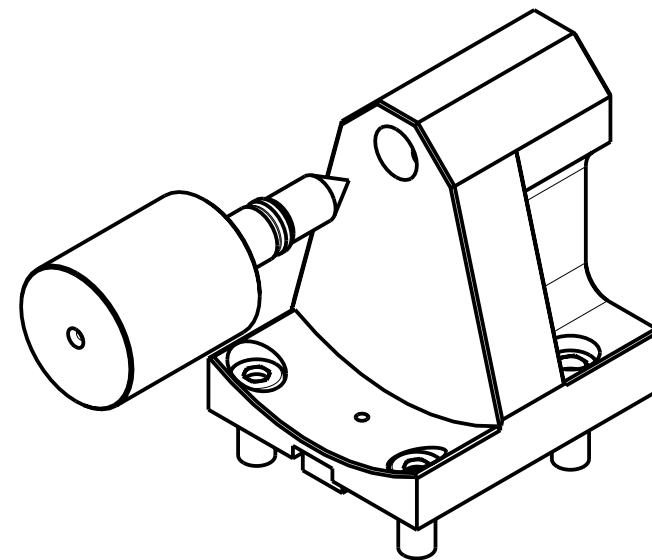
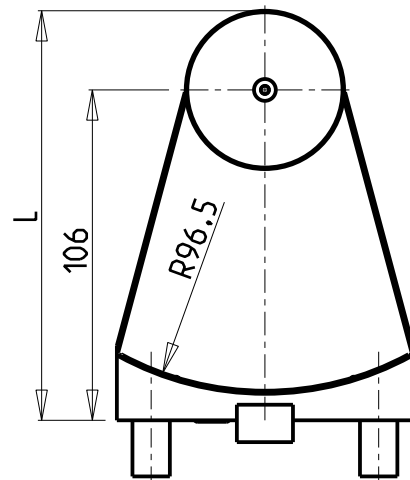
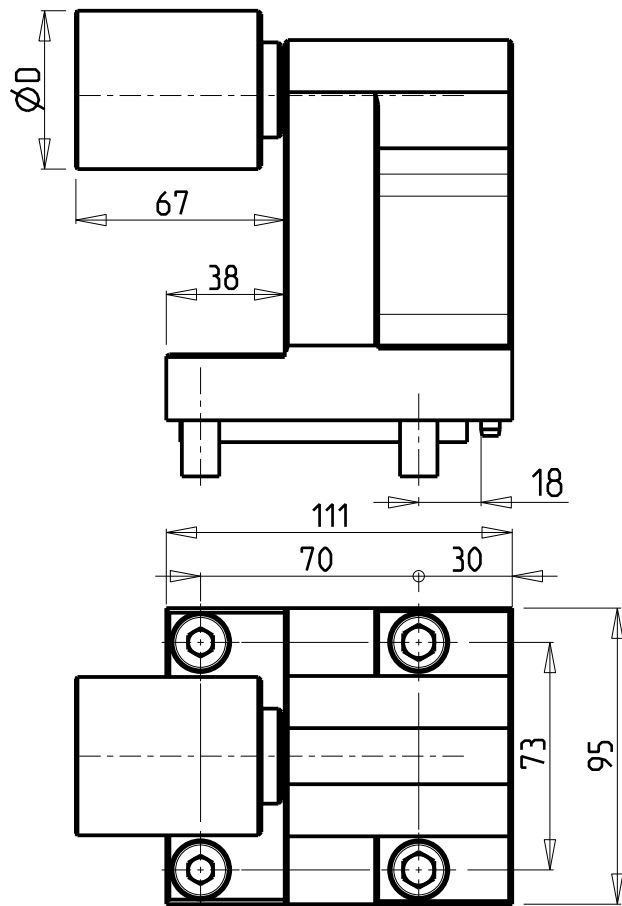

Cod. MT	N°Utensili N° Tools N° Werkzeuge	D	L
0820200	1	38	125
0820200L	1	2"	131.4

GOODWAY

MOD: GTX2000/2600 12ST. - GTZ2000/2600 12ST. - GS2000/2800 16ST. - GMT2000 - GMS2000 15ST. - GLS2800/3300 12ST.

CONTROPUNTA PER CONTROMANDRINO

Tailstock for subspindle

Gegenspitz fuer Gegenspindel

Subject to change without notice.

M.T. srl

Via Casino Albini 480
Tel. 0541/956034-957884
Fax 0541/956341

47842 S. GIOVANNI IN M. (RN)
e-mail: mtma@mtmarchetti.com
http://www.mtmarchetti.com

PRODUZIONE MODULI ROTANTI



PAGINA GDW950-4-00

10/2018

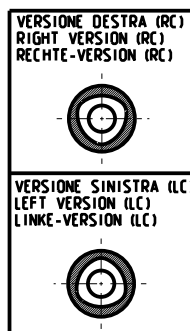
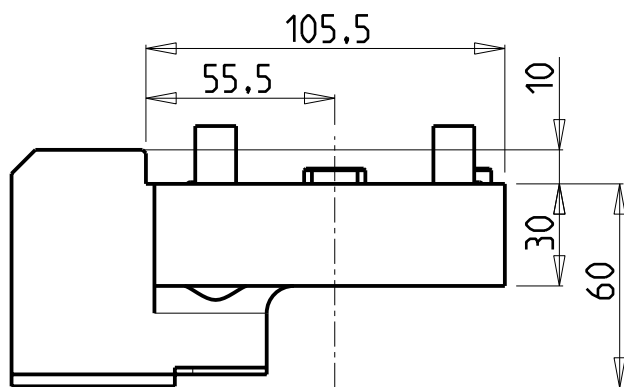
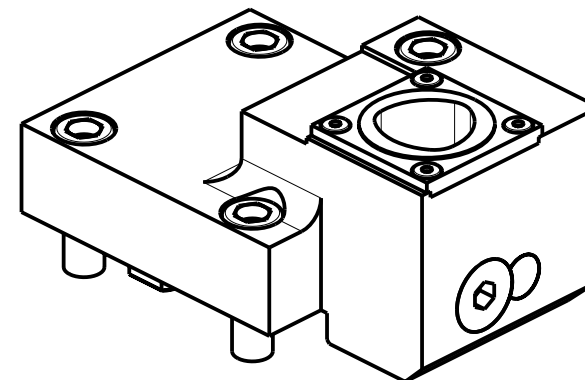
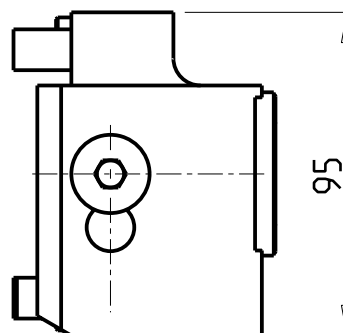
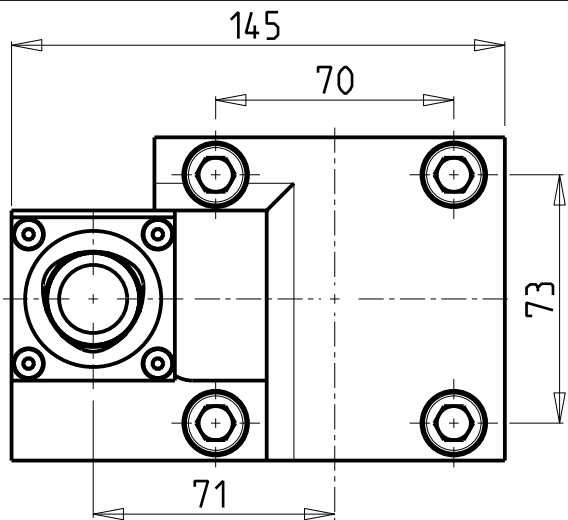

**PER ORDINARE LA VERSIONE SX
AGGIUNGERE "LC" AL CODICE IN TABELLA.
ES: MNL0464010 DIVENTA MNL0464010LC**

**TO ORDER LEFT VERSION
ADD A "LC" IN THE CODE-CHARTS.
EXAMPLE: MNL0464010 BECOMES MNL0464010LC**

**UM DIE LINKE-VERSION ZU BESTELLEN, BEI DER
ARTIKELBEZEICHNUNG "LC" HINZUFUEGEN.
BEISPIEL: MNL0464010 WIRD DANN MNL0464010LC**

Cod. MT	N°Utensili N°Tools N°Werkzeuge	Lubrificazione int. Coolant through Innenkuehlung	Reversibile lato mandrino/contromandrino Reversible sub/main spindle side Umkehrbare Spindelseite/ Gegenspindelseite	TAGLIA Size Masse
DW01384010	1	X	X	C4

GOODWAY

MOD: GTX2000/2600 12ST. - GTZ2000/2600 12ST. - GS2000/2800 16ST. - GMT2000 - GMS2000 15ST. - GLS2800/3300 12ST.

PORTAUTENSILE RADIALE SINGOLO ARRETRATO MT CAPTO

Single rear-set radial static tool MT CAPTO

Radial Single-Werkzeughalter zurueckversetzt MT CAPTO

Subject to change without notice.

M.T. srl

Via Casino Albini 480
Tel. 0541/956034-957884
Fax 0541/956341
47842 S. GIOVANNI IN M. (RN)
e-mail: mtma@tmarchetti.com
http://www.tmmarchetti.com

PRODUZIONE MODULI ROTANTI



PAGINA GDW430-D-40

