

		PAGINA Page Seite
MODULO MOTORIZZATO RADIALE Radial driven tool Radial angetriebenes Werkzeug		MSL010.1.00
MODULO MOTORIZZATO RADIALE 2 USCITE IN Y Radial single side twin head driven tool in Y Radial angetriebenes Werkzeug 2 Ausgaenge in Y		MSL080.1.00
MODULO MOTORIZZATO ASSIALE Axial driven tool Axial angetriebenes Werkzeug		MSL150.1.10
MODULO MOTORIZZATO ASSIALE MOLTIPLICATO I = 1:5.625 Axial geared-up I=1:5.625 driven tool Axial angetriebenes Werkzeug uebersetzt I=1:5.625		MSL210.1.10
MODULO MOTORIZZATO ORIENTABILE ±90° ±90° adjustable angle driven tool Angetriebenes Werkzeug schwenkbar ±90°		MSL333.1.00
MODULO MOTORIZZATO ORIENTABILE ±90° CON NONIO DIGITALE ±90° adjustable angle driven tool with digital display Angetriebenes Werkzeug schwenkbar ±90° mit digital display		MSL333.1.01
MODULO MOTORIZZATO ORIENTABILE ±90° ±90° adjustable angle driven tool Angetriebenes Werkzeug schwenkbar ±90°		MSL335.1.00
MODULO MOTORIZZATO ORIENTABILE ±90° CON NONIO DIGITALE ±90° adjustable angle driven tool with digital display Angetriebenes Werkzeug schwenkbar ±90° mit digital display		MSL335.1.01
MODULO MOTORIZZATO ORIENTABILE ±90° MOLTIPLICATO I=1:2 ±90° adjustable angle driven tool geared-up I=1:2 Angetriebenes Werkzeug schwenkbar ±90° uebersetzt I=1:2		MSL336.1.00
MODULO MOTOR. ORIENTAB. +/-90° MOLTIPL. I=1:2 CON NONIO DIGITALE +/-90° adjustable angle driven tool geared-up I=1:2 with digital display Angetriebenes Werkzeug schwenkbar +/-90° uebersetzt I=1:2 mit digital display		MSL336.1.01

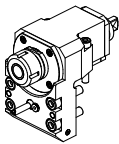
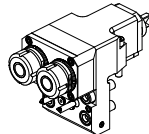
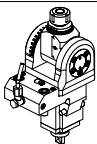
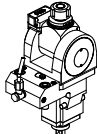
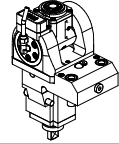
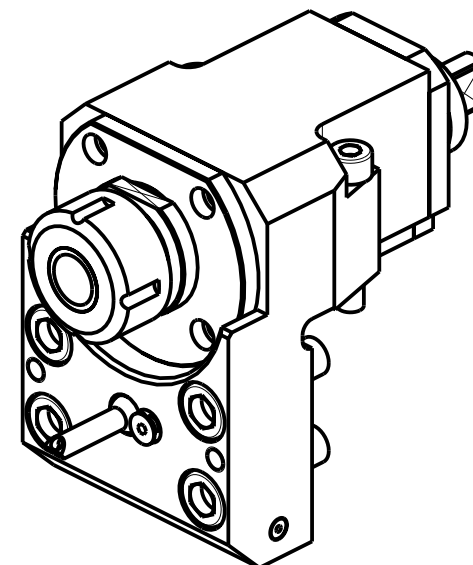
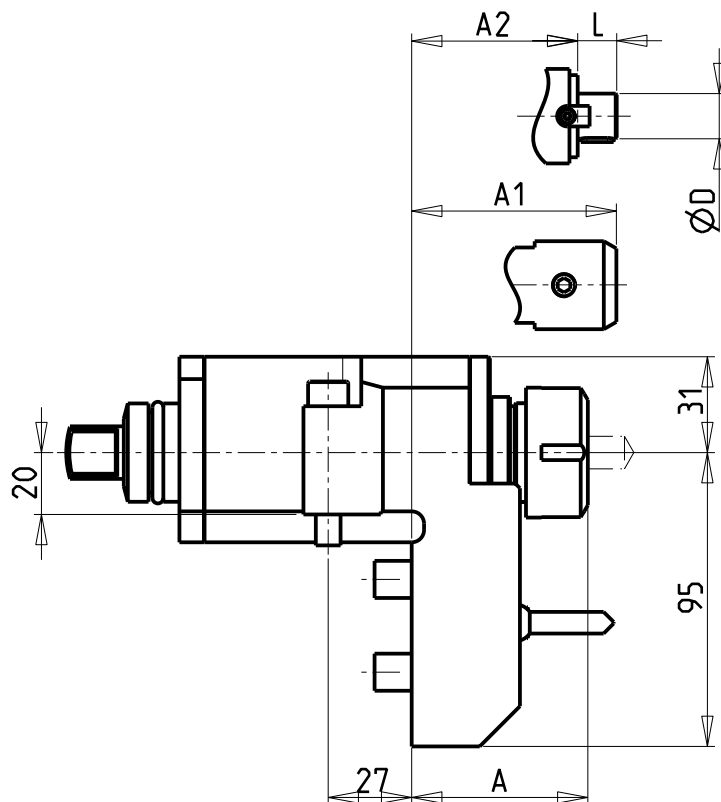
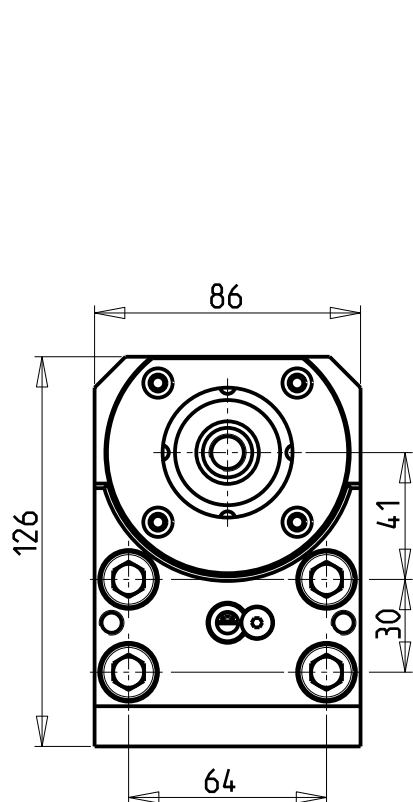

- Chiave inclusa
- Key included
- Schluessel inbegriffen

Cod. MT	Cod. MORI-SEIKI	Mandrino Spindle Spindel	I	RPM	Coppia Max Max Torque Max Drehmoment	Lubrificazione int. Coolant through Innenkuehlung	Lubrificazione est. Ext. coolant Aussenkuehlung	A	A1	A2	D	L	CHIAVI NON INCLUDE Keys not included Schluessel nicht einbegriffen	
M0020225	T32107B05	ER25	1:1	6000	40Nm	-	X	56.96	-	-	-	-	CHUB36	CHSTER25
M0021225	-	ER25	1:1	6000	40Nm	P=30bar	-	71.46	-	-	-	-	CHUB36	CHSTER25
M0020132	-	ER32	1:1	6000	40Nm	-	X	65.96	-	-	-	-	CHUB36	CHSTER32
M0021617	-	Ø16x17	1:1	6000	40Nm	-	X	-	-	37	16	17	CHUB36	CH_VTCROCE_M08
M0020325	-	WELDON 25	1:1	6000	40Nm	-	X	-	76.8	-	-	-	-	-

DMG-MORI
SL-ZL150/153/154(MC-SMC-Y-SY) DL150MC DL15MC

MODULO MOTORIZZATO RADIALE
Radial driven tool
Radial angetriebenes Werkzeug

Subject to change without notice.

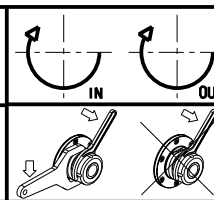

M.T. srl
Via Casino Albini 480
Tel. 0541/956034-957884
Fax 0541/956341
47842 S. GIOVANNI IN M. (RN)
e-mail: mtma@mtmarchetti.com
http://www.mtmarchetti.com

PRODUZIONE MODULI ROTANTI



PAGINA MSL010-1-00

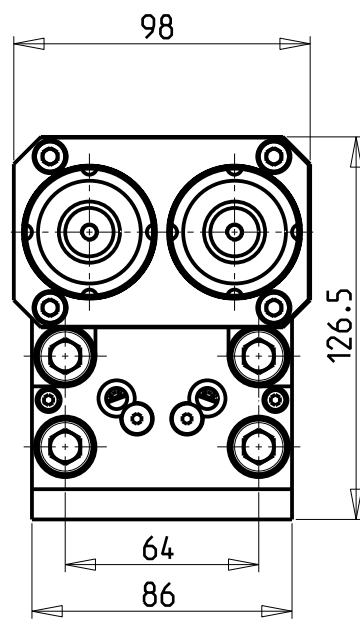
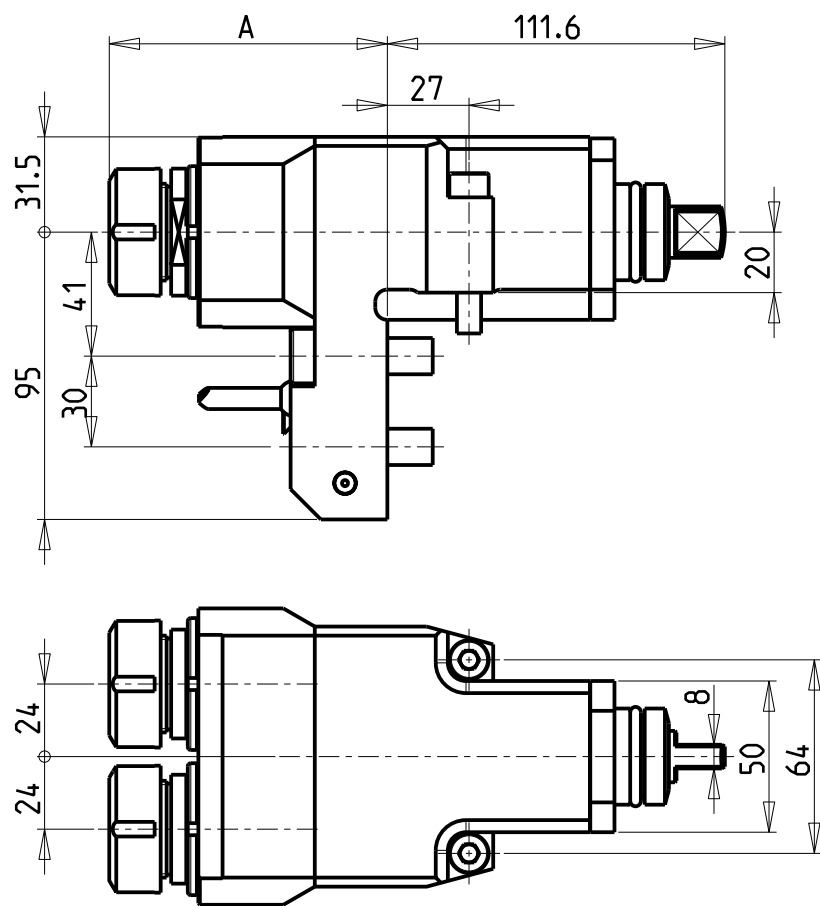

ATTENZIONE - ATTENTION - ACHTUNG

- Per lo smontaggio degli utensili utilizzare sempre la chiave di contrasto come indicato nel manuale d'uso.
- For disassembly of the tools use always the contrast key as mentioned in the user instructions.
- Fuer das Abmontieren der Werkzeuge immer den Gegenschlüssel benutzen wie in der Bedienungsanleitung erwäehnt.

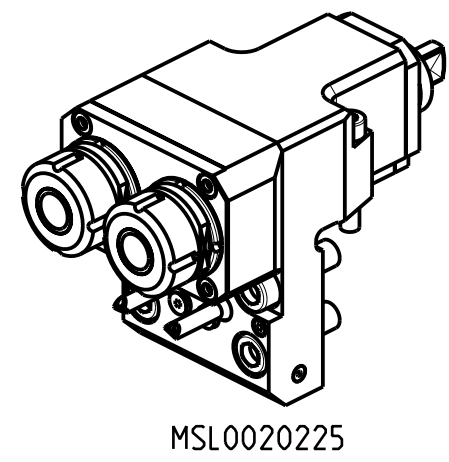
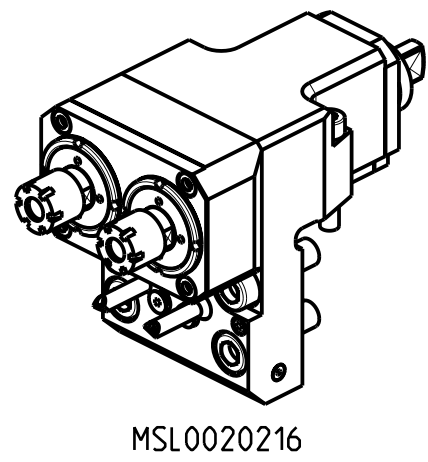

Cod. MT	Mandrino Spindel	I	RPM	Coppia Max Max Torque Max Drehmoment	Lubrificazione est. Ext. coolant Aussenkuehlung	A	CHIAVI NON INCLUSE Keys not included Schluesstel nicht einbegriffen	
							CHUB17	CHMNER16
MSL0020216	ER16	1:1	6000	30Nm	X	91.5	CHUB17	CHMNER16
MSL0020225	ER25	1:1	6000	30Nm	X	91.96	CHUB36	CHSTER25

DMG-MORI
SL-ZL150/153/154(MC-SMC-Y-SY) DL150MC DL15MC

MODULO MOTORIZZATO RADIALE 2 USCITE IN Y
Radial single side twin head driven tool in Y
Radial angetriebenes Werkzeug 2 Ausgaenge in Y

Subject to change without notice.

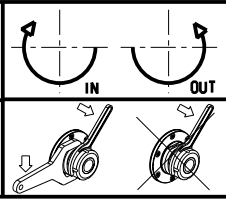

M.T. srl
Via Casino Albini 480
Tel. 0541/956034-957884
Fax 0541/956341
47842 S. GIOVANNI IN M. (RN)
e-mail: mtma@mtmarchetti.com
http://www.mtmarchetti.com

PRODUZIONE MODULI ROTANTI

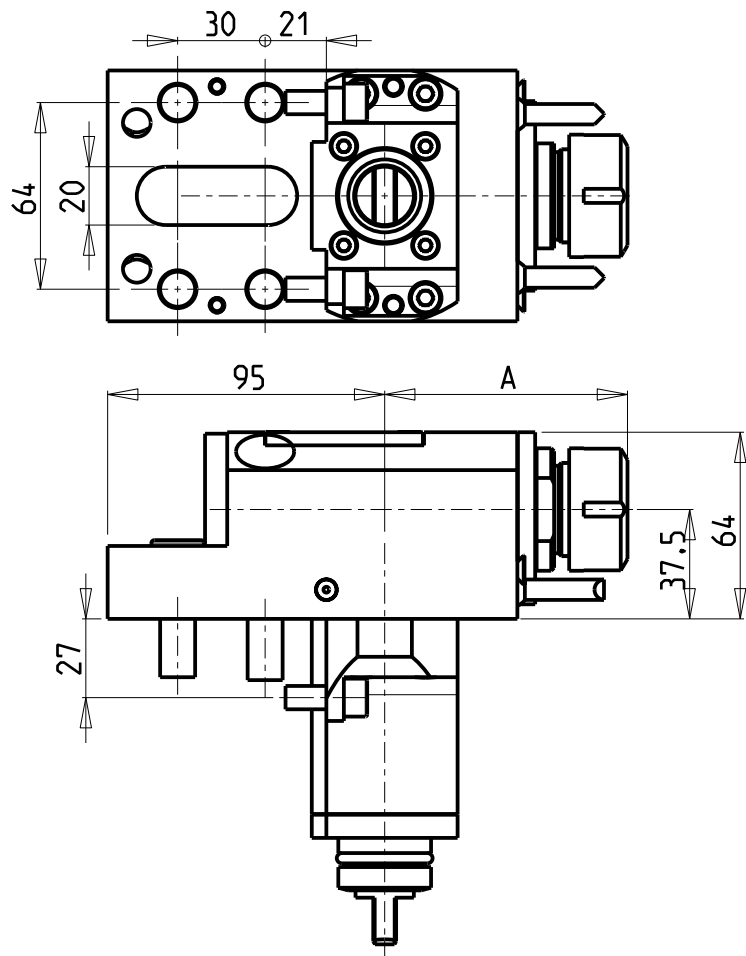
PAGINA MSL080-1-00

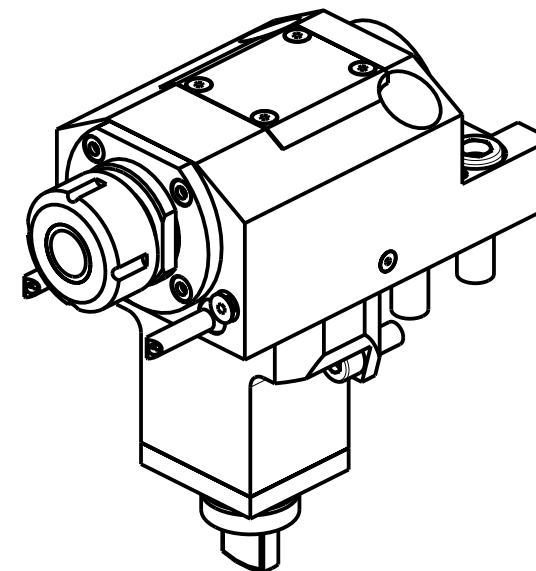

ATTENZIONE - ATTENTION - ACHTUNG

- Per lo smontaggio degli utensili utilizzare sempre la chiave di contrasto come indicato nel manuale d'uso.
- For disassembly of the tools use always the contrast key as mentioned in the user instructions.
- Fuer das Abmontieren der Werkzeuge immer den Gegenschlüssel benutzen wie in der Bedienungsanleitung erwäehnt.



Cod. MT	Cod. MORI-SEIKI	Mandrino Spindle Spindel	I	RPM	Coppia Max Max Torque Max Drehmoment	Lubrificazione int. Coolant through Innenkuehlung	Lubrificazione est. Ext. coolant Aussenkuehlung	A	CHIAVI NON INCLUSE Keys not included Schlüssel nicht einbegriffen	
M0040425	T32108B07	ER25	1:1	6000	40Nm		X	83.26	CHUB36	CHSTER25
M0041725	-	ER25	1:1	6000	40Nm	P=70bar		83.26	CHUB36	CHSTER25

DMG-MORI

SL-ZL150/153/154(MC-SMC-Y-SY) DL150MC DL15MC

MODULO MOTORIZZATO ASSIALE

Axial driven tool

Axial angetriebenes Werkzeug

Subject to change without notice.

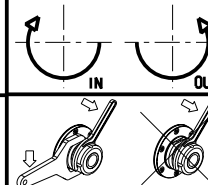

M.T. srl

Via Casino Albini 480
Tel. 0541/956034-957884
Fax 0541/956341
47842 S. GIOVANNI IN M. (RN)
e-mail: mtma@mtmarchetti.com
http://www.mtmarchetti.com

PRODUZIONE MODULI ROTANTI



PAGINA MSL150-1-10

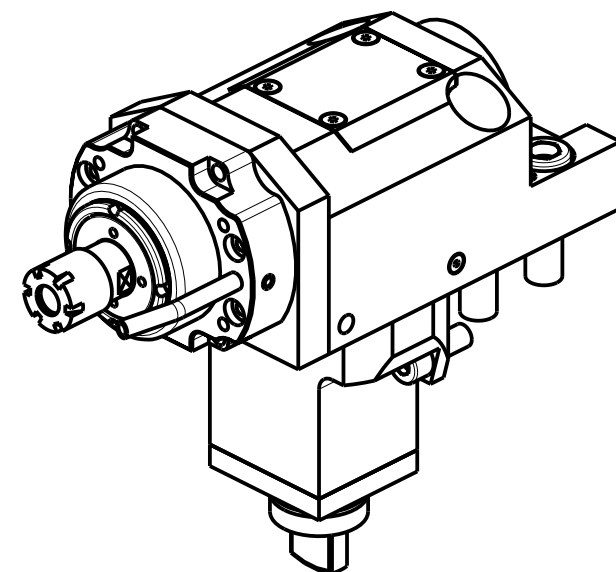
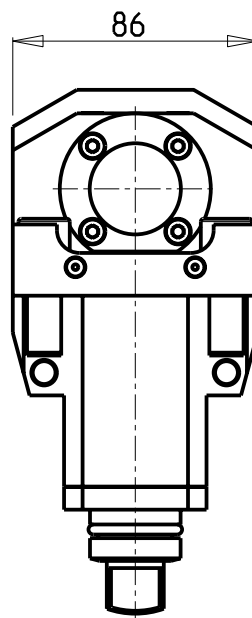
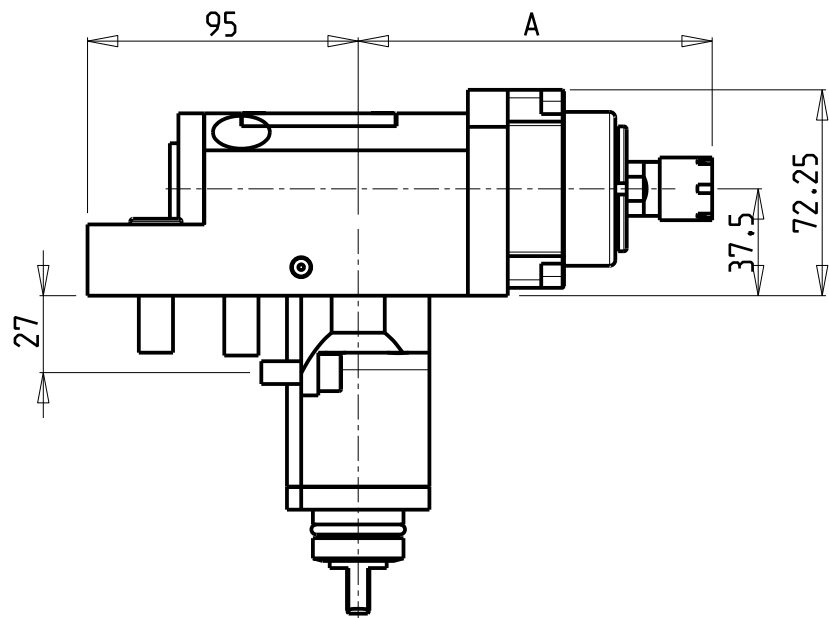
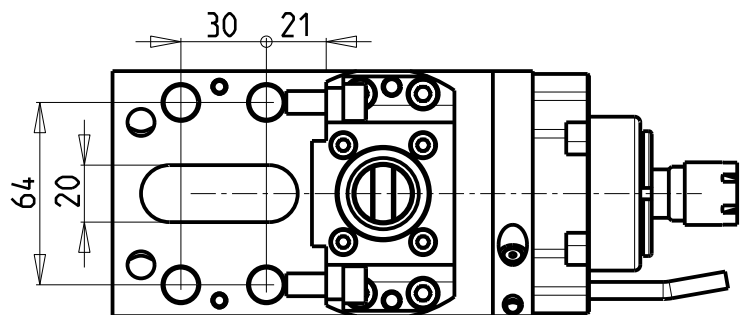

ATTENZIONE - ATTENTION - ACHTUNG

- PRIMA DI UTILIZZARE IL MOTORIZZATO CONSULTARE LE ISTRUZIONI ALLEGATE!
- BEFORE USING THE DRIVEN TOOL, PLEASE CHECK THE ENCLOSED INSTRUCTION SHEET!
- VOR DER BENUTZUNG DES ANGETRIEBENEN WERKZEUGES, DIE BEILIEGENDEN INSTRUKTIONEN DURCHLESEN!

ATTENZIONE - ATTENTION - ACHTUNG

- Per lo smontaggio degli utensili utilizzare sempre la chiave di contrasto come indicato nel manuale d'uso.
- For disassembly of the tools use always the contrast key as mentioned in the user instructions.
- Fuer das Abmontieren der Werkzeuge immer den Gegenschlüssel benutzen wie in der Bedienungsanleitung erwaeht.

Cod. MT	Mandrino Spindle Spindel	I	RPM	Coppia Max Max Torque Max Drehmoment	Lubrificazione est. Ext. coolant Aussenkuehlung	A	CHIAVI INCLUSE Keys included Schluessel einbegriffen
M0050016	ER16	1:5.625	22500	6Nm	X	124.25	CHUB17 CHMNER16

DMG-MORI
SL-ZL150/153/154(MC-SMC-Y-SY) DL150MC DL15MC

MODULO MOTORIZZATO ASSIALE MOLTIPLICATO I=1:5.625
Axial geared-up I=1:5.625 driven tool
Axial angetriebenes Werkzeug uebersetzt I=1:5.625

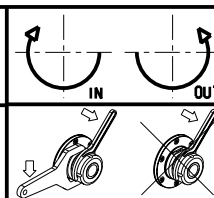

M.T. srl
Via Casino Albini 480
Tel. 0541/956034-957884
Fax 0541/956341
47842 S. GIOVANNI IN M. (RN)
e-mail: mtma@mtmarchetti.com
http://www.mtmarchetti.com

PRODUZIONE MODULI ROTANTI



PAGINA MSL210-1-10

Subject to change without notice.

10/2018

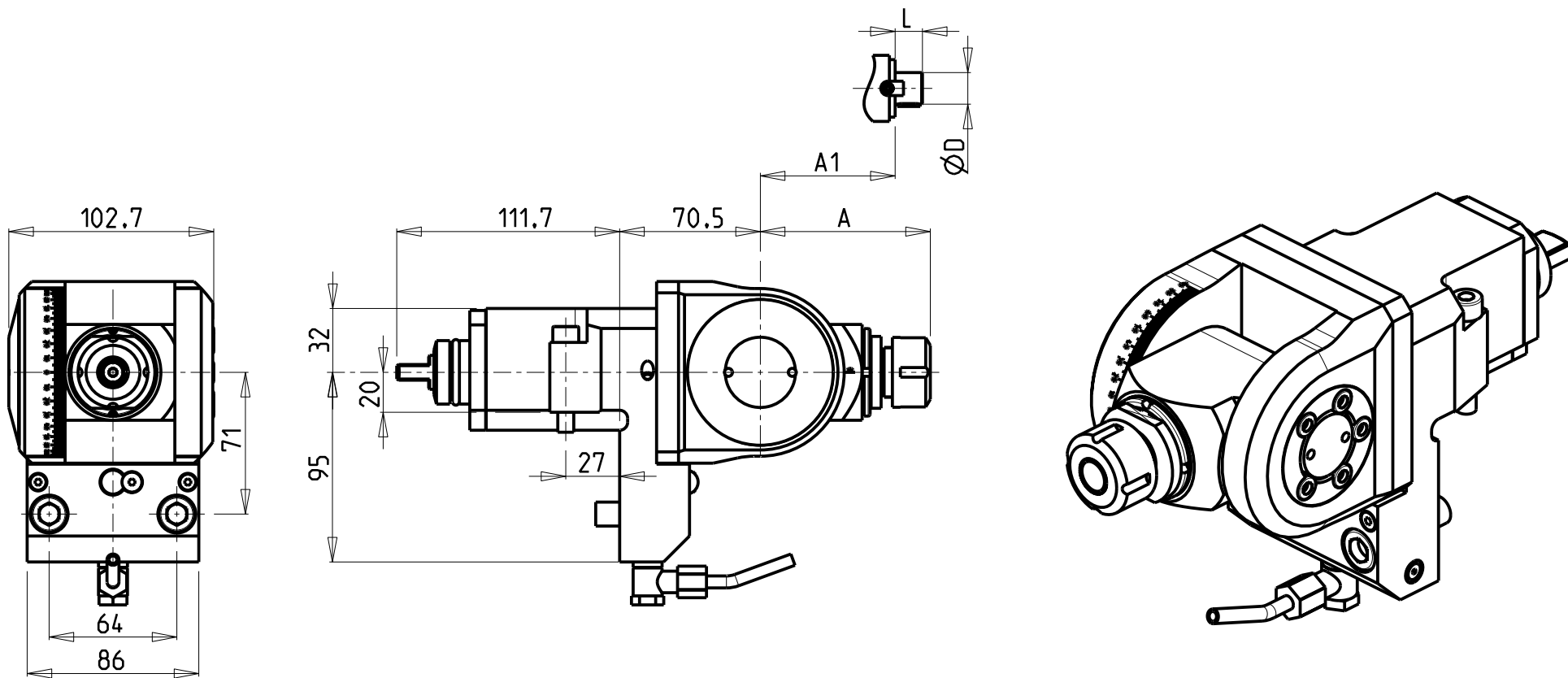

Cod. MT	Mandrino Spindle Spindel	I	RPM	Coppia Max Max Torque Max Drehmoment	Lubrificazione est. Ext. coolant Aussenkuehlung	A	A1	D	L	CHIAVI INCLUSE Keys included Schluessel inbegriffen	
MSL0240120	ER20	1:1	6000	40Nm	X	85.16	-	-	-	CHUB36	CHSTER20
MSL0240125	ER25	1:1	6000	40Nm	X	86.16	-	-	-	CHUB36	CHSTER25
MSL0240516	Ø16x17	1:1	6000	40Nm	X	-	65	16	17	CHUB36	CH_VTCROCE_M08
MSL0240522	Ø22x19	1:1	6000	40Nm	X	-	66	22	19	CHUB36	CH_VTCROCE_M10
MSL0240519	Ø3/4"x3/4"	1:1	6000	40Nm	X	-	65	3/4"	3/4"	CHUB36	CH_VTCROCE_M08

DMG-MORI

SL-ZL150/153/154(MC-SMC-Y-SY) DL150MC DL15MC

MODULO MOTORIZZATO ORIENTABILE ±90°

±90° adjustable angle driven tool

Angetriebenes Werkzeug schwenkbar ±90°

Subject to change without notice.

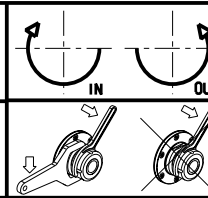

M.T. srl

Via Casino Albini 480
Tel. 0541/956034-957884
Fax 0541/956341

47842 S. GIOVANNI IN M. (RN)
e-mail: mtma@mtmarchetti.com
http://www.mtmarchetti.com

PRODUZIONE MODULI ROTANTI



PAGINA MSL333-1-00

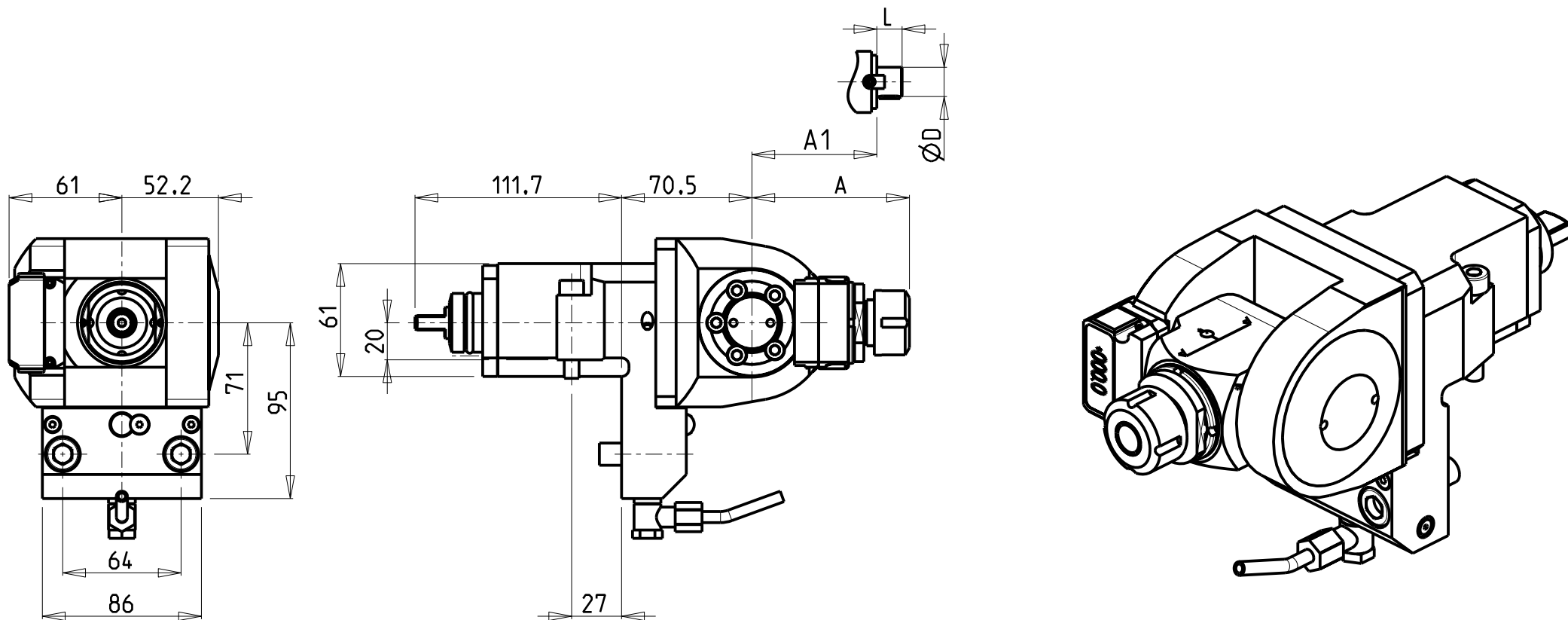

Cod. MT	Mandrino Spindle Spindel	I	RPM	Coppia Max Max Torque Max Drehmoment	Lubrificazione est. Ext. coolant Aussenkuehlung	A	A1	D	L	CHIAVI INCLUSE Keys included Schluessel inbegriffen	
MSL0200120	ER20	1:1	6000	40Nm	X	85.16	-	-	-	CHUB36	CHSTER20
MSL0200125	ER25	1:1	6000	40Nm	X	86.16	-	-	-	CHUB36	CHSTER25
MSL0200516	Ø16x17	1:1	6000	40Nm	X	-	65	16	17	CHUB36	CH_VTCROCE_M08
MSL0200522	Ø22x19	1:1	6000	40Nm	X	-	66	22	19	CHUB36	CH_VTCROCE_M10
MSL0200519	Ø3/4"x3/4"	1:1	6000	40Nm	X	-	65	3/4"	3/4"	CHUB36	CH_VTCROCE_M08

DMG-MORI
SL-ZL150/153/154(MC-SMC-Y-SY) DL150MC DL15MC

MODULO MOTORIZZATO ORIENTABILE ±90° CON NONIO DIGITALE
±90° adjustable angle driven tool with digital display
Angetriebenes Werkzeug schwenkbar ±90° mit digital display

Subject to change without notice.

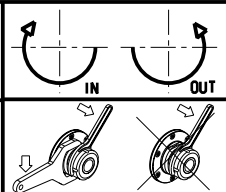

M.T. srl
Via Casino Albini 480
Tel. 0541/956034-957884
Fax 0541/956341
47842 S. GIOVANNI IN M. (RN)
e-mail: mtma@mtmarchetti.com
http://www.mtmarchetti.com

PRODUZIONE MODULI ROTANTI



PAGINA MSL333-1-01

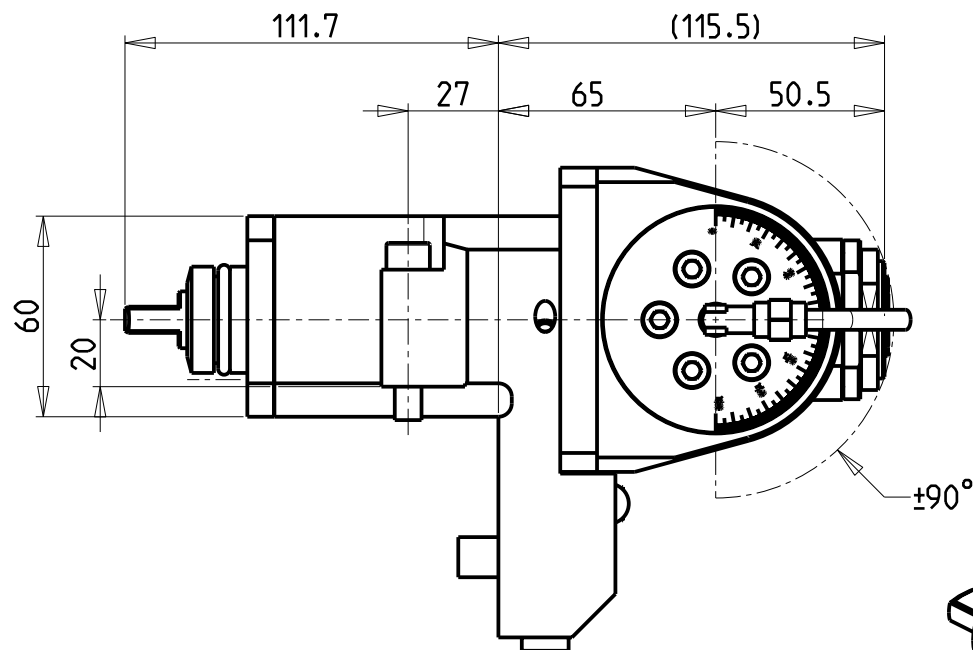
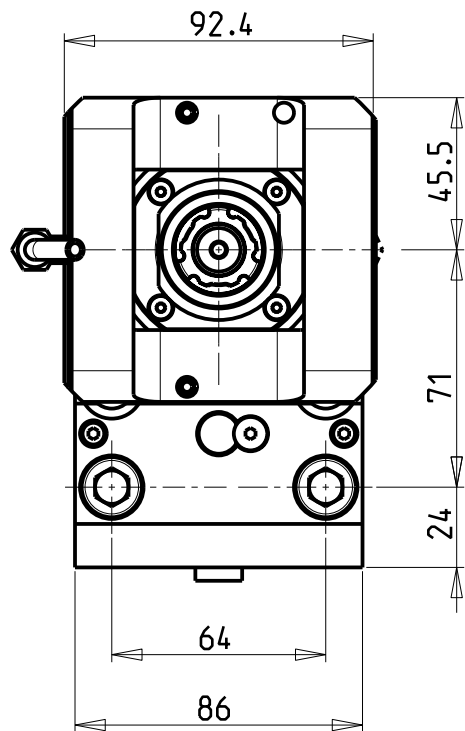

ATTENZIONE - ATTENTION - ACHTUNG

- Per lo smontaggio degli utensili utilizzare sempre la chiave di contrasto come indicato nel manuale d'uso.
- For disassembly of the tools use always the contrast key as mentioned in the user instructions.
- Fuer das Abmontieren der Werkzeuge immer den Gegenschlüssel benutzen wie in der Bedienungsanleitung erwaeht.

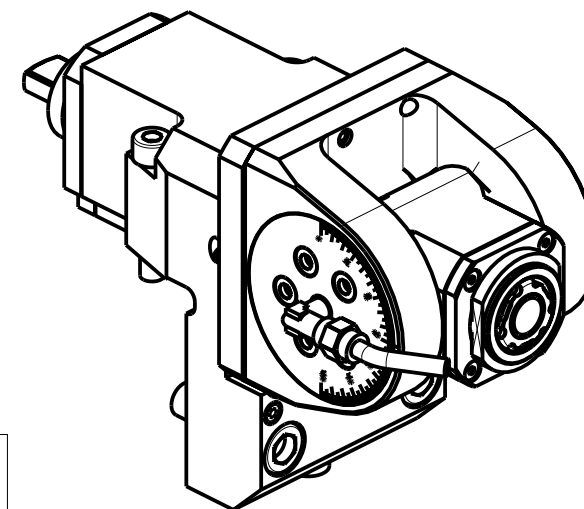

Non utilizzabile sulla torretta sinistra dei modelli DL15 e DL151 in quanto fuori volteggio
 Do not use on left turret of models DL15 and DL151. Out of max. dimensions of rotation!
 Nicht auf linken Revolver der Modelle DL15 und DL 151 benutzen. Sie befindet sich ausser Raumbedarf bei Drehung!

Cod. MT	Mandrino Spindle Spindel	I	RPM	Coppia Max Max Torque Max Drehmoment	Lubrificazione int. Coolant through Innenkuehlung	Lubrificazione est. Ext. coolant Aussenkuehlung	CHIAVI INCLUDE Keys included Schluessel inbegriffen		
MSL0110120	ER A 20	1:1	6000	30Nm		X	CHUB36	CHUB22	CHTAER20ZC
MSL0110220	ER A 20	1:1	6000	30Nm	P=70bar	X	CHUB36	CHUB22	CHTAER20ZC

DMG-MORI

MOD: SL-ZL150/153/154(MC-SMC-Y-SY) DL150MC DL15MC

MODULO MOTORIZZATO ORIENTABILE +/-90°

+/-90° adjustable angle driven tool

Angetriebenes Werkzeug schwenkbar +/-90°

Subject to change without notice.

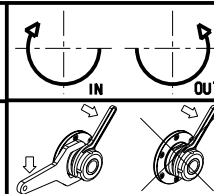

M.T. srl

Via Casino Albini 480
 Tel. 0541/956034-957884
 Fax 0541/956341
 47842 S. GIOVANNI IN M. (RN)
 e-mail: mtma@mtmarchetti.com
 http://www.mtmarchetti.com

PRODUZIONE MODULI ROTANTI



PAGINA MSL335-1-00

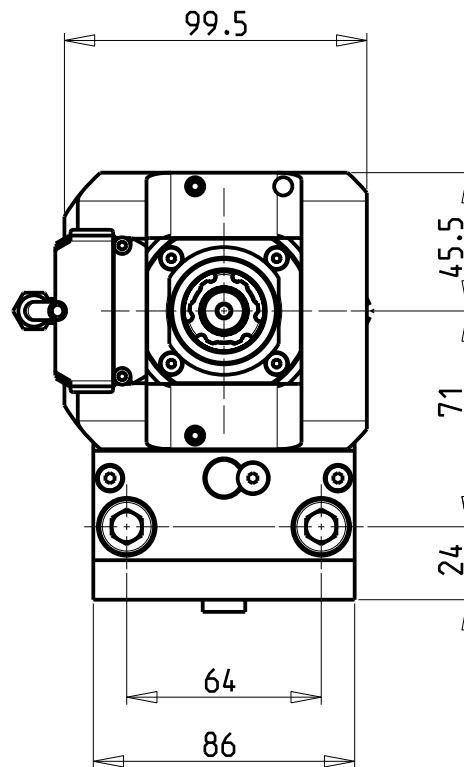
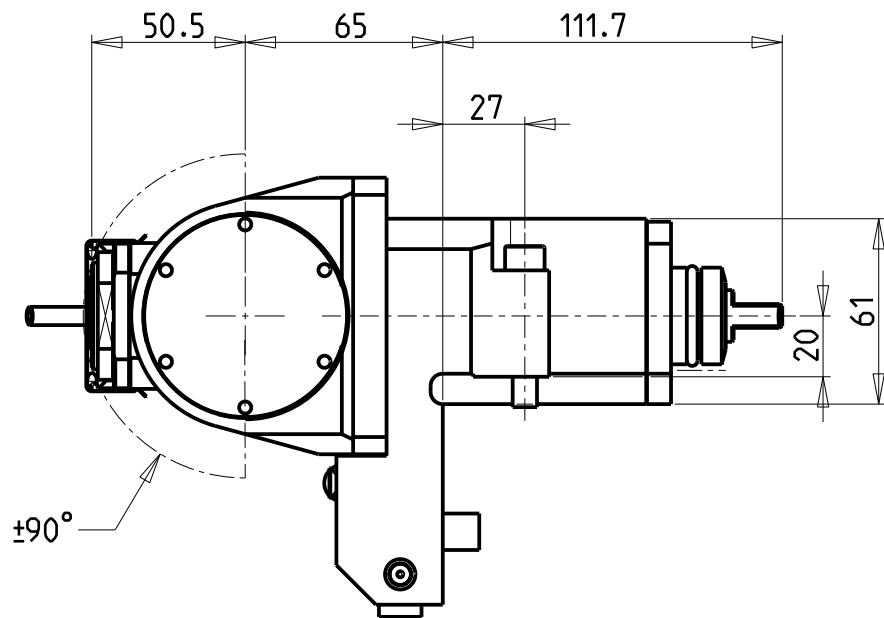

ATTENZIONE - ATTENTION - ACHTUNG

- Per lo smontaggio degli utensili utilizzare sempre la chiave di contrasto come indicato nel manuale d'uso.
- For disassembly of the tools use always the contrast key as mentioned in the user instructions.
- Fuer das Abmontieren der Werkzeuge immer den Gegenschlüssel benutzen wie in der Bedienungsanleitung erwäehnt.

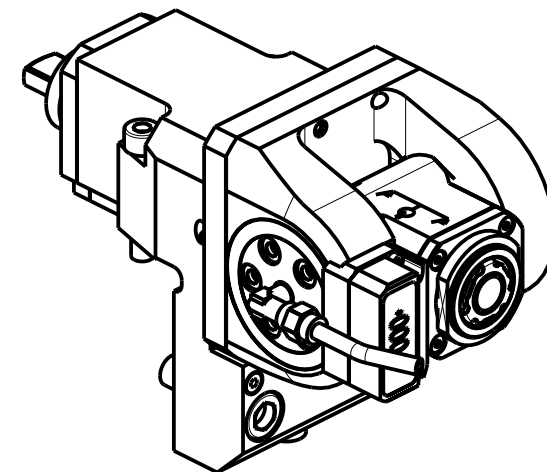

Non utilizzabile sulla torretta sinistra dei modelli DL15 e DL151 in quanto fuori voltaggio
 Do not use on left turret of models DL15 and DL151. Out of max. dimensions of rotation!
 Nicht auf linken Revolver der Modelle DL15 und DL 151 benutzen. Sie befindet sich ausser Raumbedarf bei Drehung!

Cod. MT	Mandrino Spindle Spindel	I	RPM	Coppia Max Max Torque Max Drehmoment	Lubrificazione int. Coolant through Innenkuehlung	Lubrificazione est. Ext. coolant Ausenkuehlung	CHIAVI INCLUDE Keys included Schluessel inbegriffen		
							CHUB36	CHUB22	CHTAER20ZC
MSL0115120	ER A 20	1:1	6000	30Nm	-	X	CHUB36	CHUB22	CHTAER20ZC
MSL0115220	ER A 20	1:1	6000	30Nm	P=70bar	X	CHUB36	CHUB22	CHTAER20ZC

DMG-MORI

MOD: SL-ZL150/153/154(MC-SMC-Y-SY) DL150MC DL15MC

MODULO MOTORIZZATO ORIENTABILE ±90° CON NONIO DIGITALE

±90° adjustable angle driven tool with digital display

Angetriebenes Werkzeug schwenkbar ±90° mit digital display

Subject to change without notice.

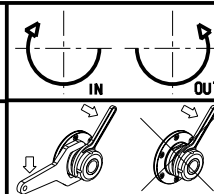

M.T. srl

Via Casino Albini 480
 Tel. 0541/956034-957884
 Fax 0541/956341
 47842 S. GIOVANNI IN M. (RN)
 e-mail: mtma@mtmarchetti.com
 http://www.mtmarchetti.com

PRODUZIONE MODULI ROTANTI



PAGINA MSL335-1-01

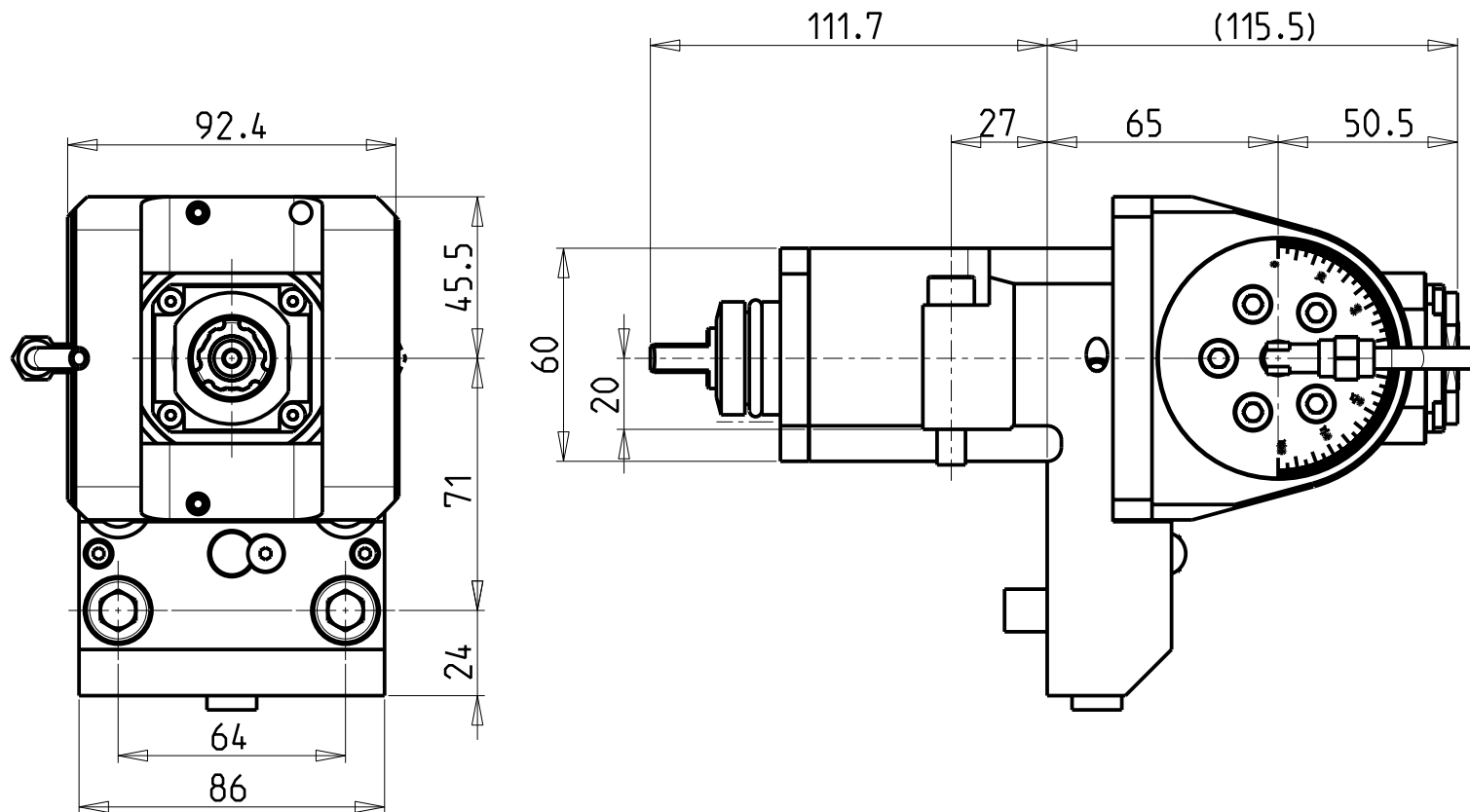

ATTENZIONE - ATTENTION - ACHTUNG

- Per lo smontaggio degli utensili utilizzare sempre la chiave di contrasto come indicato nel manuale d'uso.
- For disassembly of the tools use always the contrast key as mentioned in the user instructions.
- Fuer das Abmontieren der Werkzeuge immer den Gegenschlüssel benutzen wie in der Bedienungsanleitung erwaeht.

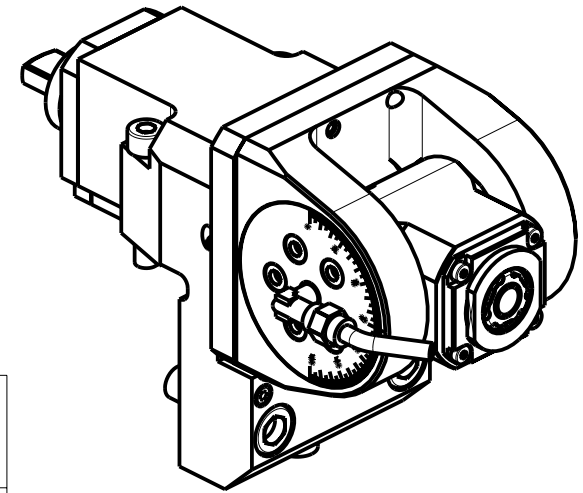

Non utilizzabile sulla torretta sinistra dei modelli DL15 e DL151 in quanto fuori volteggio
 Do not use on left turret of models DL15 and DL151. Out of max. dimensions of rotation!
 Nicht auf linken Revolver der Modelle DL15 und DL 151 benutzen. Sie befindet sich ausser Raumbedarf bei Drehung!

Cod. MT	Mandrino Spindle Spindel	I	RPM	Coppia Max Max Torque Max Drehmoment	Lubrificazione int. Coolant through Innenkuehlung	Lubrificazione est. Ext. coolant Aussenkuehlung	CHIAVI INCLUSE Keys included Schluesssel inbegriffen		
MSL0110316	ERA16	1:2	12000	8Nm		X	CHUB19_SP3	CHUB32	CHTAER16ZC
MSL0110416	ERA16	1:2	12000	8Nm	P=70bar	X	CHUB19_SP3	CHUB32	CHTAER16ZC

DMG-MORI
 SL-ZL150/153/154(MC-SMC-Y-SY) DL150MC DL15MC

MODULO MOTORIZZATO ORIENTABILE +/-90° MOLTIPLICATO I=1:2
 +/-90° adjustable angle driven tool geared-up I=1:2
 Angetriebenes Werkzeug schwenkbar +/-90° uebersetzt I=1:2

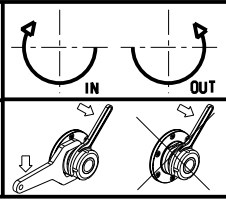

M.T. srl
 Via Casino Albini 480
 Tel. 0541/956034-957884
 Fax 0541/956341
 47842 S. GIOVANNI IN M. (RN)
 e-mail: mtma@mtmarchetti.com
 http://www.mtmarchetti.com

PRODUZIONE MODULI ROTANTI

 PAGINA MSL336-1-00

Subject to change without notice.

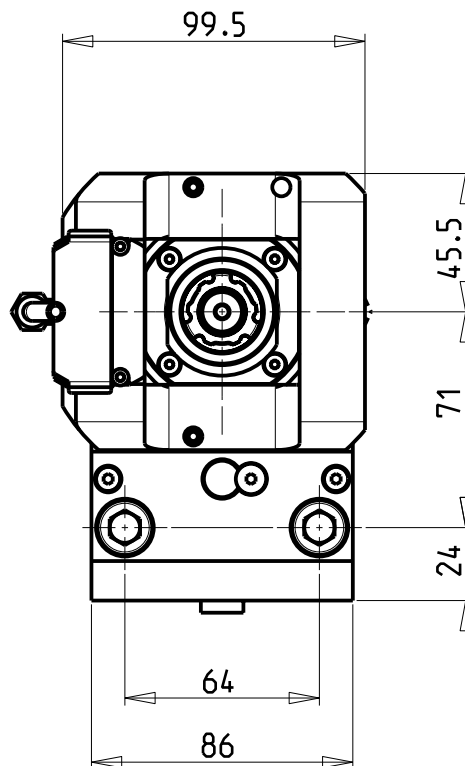
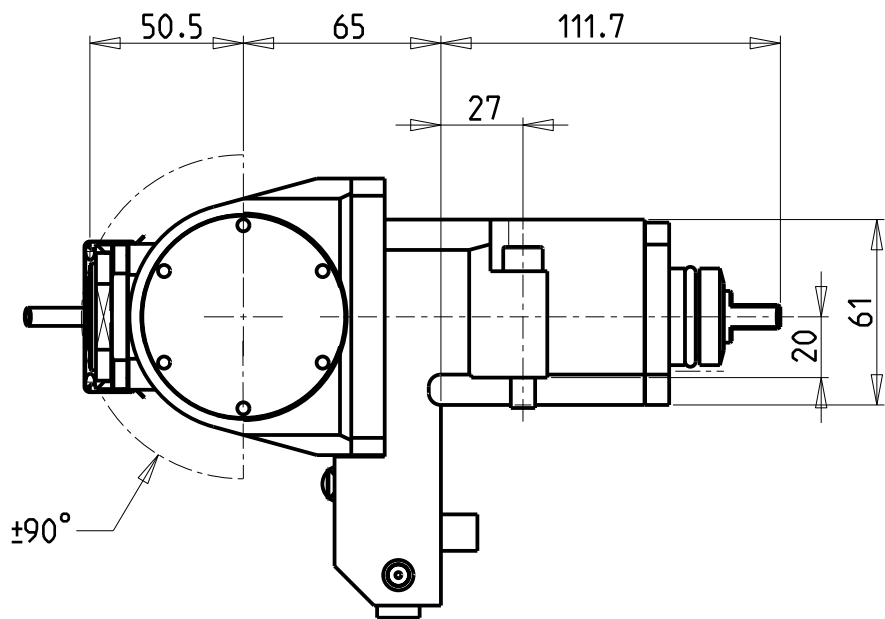

ATTENZIONE - ATTENTION - ACHTUNG

- Per lo smontaggio degli utensili utilizzare sempre la chiave di contrasto come indicato nel manuale d'uso.
- For disassembly of the tools use always the contrast key as mentioned in the user instructions.
- Fuer das Abmontieren der Werkzeuge immer den Gegenschlüssel benutzen wie in der Bedienungsanleitung erwäehnt.

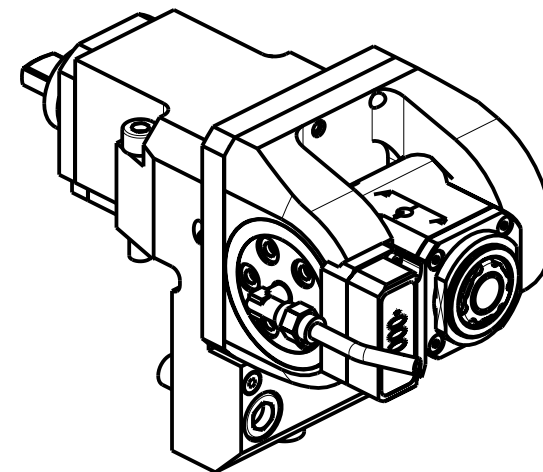

Non utilizzabile sulla torretta sinistra dei modelli DL15 e DL151 in quanto fuori volteggio
 Do not use on left turret of models DL15 and DL151. Out of max. dimensions of rotation!
 Nicht auf linken Revolver der Modelle DL15 und DL 151 benutzen. Sie befindet sich ausser Raumbedarf bei Drehung!

Cod. MT	Mandrino Spindle Spindel	I	RPM	Coppia Max Max Torque Max Drehmoment	Lubrificazione int. Coolant through Innenkuehlung	Lubrificazione est. Ext. coolant Aussenkuehlung	CHIAVI INCLUSE Keys included Schluesssel inbegriffen		
MSL0115316	ERA16	1:2	12000	8Nm	-	X	CHUB19_SP3	CHUB32	CHTAER16ZC
MSL0115416	ERA16	1:2	12000	8Nm	P=70bar	X	CHUB19_SP3	CHUB32	CHTAER16ZC

DMG-MORI

SL-ZL150/153/154(MC-SMC-Y-SY) DL150MC DL15MC

MODULO MOTORIZZATO ORIENTABILE +/-90° MOLTIPLICATO I=1:2 CON NONIO DIGITALE

+/-90° adjustable angle driven tool geared-up I=1:2 with digital display

Angetriebenes Werkzeug schwenkbar +/-90° uebersetzt I=1:2 mit digital display

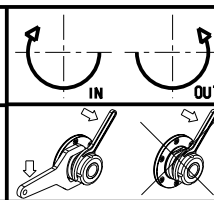

M.T. srl

Via Casino Albini 480
 Tel. 0541/956034-957884
 Fax 0541/956341
 47842 S. GIOVANNI IN M. (RN)
 e-mail: mtma@mtmarchetti.com
 http://www.mtmarchetti.com

PRODUZIONE MODULI ROTANTI



PAGINA MSL336-1-01

Subject to change without notice.

10/2018