

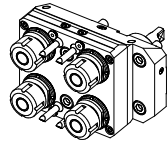
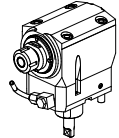
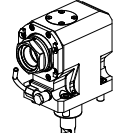
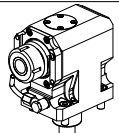
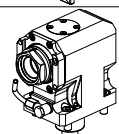
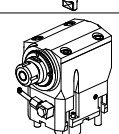
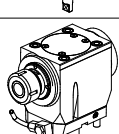
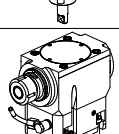
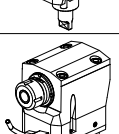
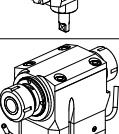
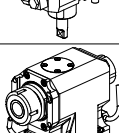
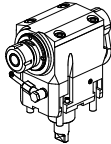
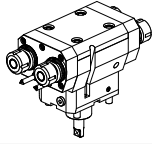
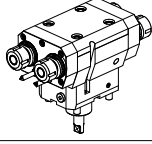
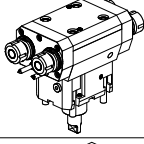
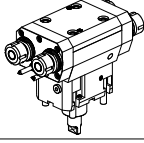
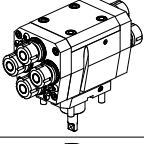
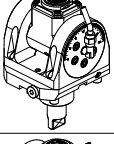
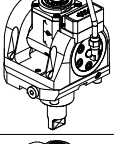
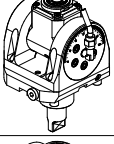
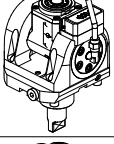

		PAGINA Page Seite
MODULO MOTORIZZATO RADIALE Radial driven tool Radial angetriebenes Werkzeug		MNZ010.1.00
MODULO MOTORIZZATO RADIALE MTSK Radial MTSK driven tool Radial MTSK angetriebenes Werkzeug		MNZ010.1.00.K
MODULO MOTORIZZATO RADIALE 12000 RPM Radial driven tool 12000 rpm Radial angetriebenes Werkzeug 12000 rpm		MNZ010.1.01
MODULO MOTORIZZATO RADIALE MTSK 12000 RPM Radial MTSK driven tool 12000 rpm Radial MTSK angetriebenes Werkzeug 12000 rpm		MNZ010.1.01.K
MODULO MOTORIZZATO RADIALE ALTA PRESSIONE Radial driven tool high pressure Radial angetriebenes Werkzeug hochdruck		MNZ010.1.20
MODULO MOTORIZZATO RADIALE 12000 RPM Radial driven tool 12000 rpm Radial angetriebenes Werkzeug 12000 rpm		MNZ010.1.21
MODULO MOTORIZZATO RADIALE MAGGIORATO Radial reinforced driven tool Radial angetriebenes Werkzeug vergrößert		MNZ020.1.00
MODULO MOTORIZZATO RADIALE DISASSATO IN Z 90mm Radial driven tool re-directed in Z by 90mm Radial angetriebenes Werkzeug achsversetzt in Z um 90mm		MNZ030.1.10
MODULO MOTORIZZATO RADIALE RIDOTTO 1=2:1 DISASSATO IN Z 90mm Radial geared-down 1=2:1 driven tool re-directed in Z by 90mm Radial angetriebenes Werkzeug untersetzt 1=2:1 achsversetzt in Z um 90mm		MNZ030.1.20
MODULO MOTOR. RADIALE MOLTIPLICATO 1=1:2 DISASSATO IN Z 90mm Radial geared-up 1=1:2 driven tool re-directed in Z by 90mm Radial angetriebenes Werkzeug uebersetzt 1=1:2 achsversetzt in Z um 90mm		MNZ030.1.30
MODULO MOTORIZZATO RADIALE DISASSATO IN Z 36mm 12000 RPM Radial driven tool re-directed in Z by 36mm 12000 rpm Radial angetriebenes Werkzeug achsversetzt in Z um 36mm 12000 rpm		MNZ033.1.11
MODULO MOTORIZZATO RADIALE 2 USCITE IN Y Radial single side twin head driven tool in Y Radial angetriebenes Werkzeug 2 Ausgaenge ueberlagert in Y		MNZ080.1.00

		PAGINA Page Seite
MODULO MOTORIZZATO RADIALE 4 USCITE Radial 4 head driven tool Radial angetriebenes Werkzeug 4 Ausgaenge		MNZ100.1.00
MODULO MOTORIZZATO ASSIALE H=85mm Axial driven tool H=85mm Axial angetriebenes Werkzeug H=85mm		MNZ150.1.10
MODULO MOTORIZZATO ASSIALE MTSK H=85mm Axial MTSK driven tool H=85mm Axial MTSK angetriebenes Werkzeug H=85mm		MNZ150.1.10.K
MODULO MOTORIZZATO ASSIALE 12000 RPM H=85mm Axial driven tool 12000 rpm H=85mm Axial angetriebenes Werkzeug 12000 rpm H=85mm		MNZ150.1.11
MODULO MOTORIZZATO ASSIALE MTSK 12000 RPM H=85mm Axial MTSK driven tool 12000 rpm H=85mm Axial MTSK angetriebenes Werkzeug 12000 rpm H=85mm		MNZ150.1.11.K
MODULO MOTORIZZATO ASSIALE H=100mm Axial driven tool H=100mm Axial angetriebenes Werkzeug H=100mm		MNZ150.1.20
MODULO MOTORIZZATO ASSIALE RIDOTTO I=2:1 Axial geared-down I=2:1 driven tool Axial angetriebenes Werkzeug untersetzt I=2:1		MNZ190.1.10
MODULO MOTORIZZATO ASSIALE MOLTIPLICATO I=1:2 H=85mm Axial geared-up I=1:2 driven tool H=85mm Axial angetriebenes Werkzeug uebersetzt I=1:2 H=85mm		MNZ200.1.10
MODULO MOTORIZZATO ASSIALE MOLTIPLICATO I=1:2 H=100mm Axial geared-up I=1:2 driven tool H=100mm Axial angetriebenes Werkzeug uebersetzt I=1:2 H=100mm		MNZ200.1.20
MODULO MOTOR ASSIALE PER POLIGONATURA INTERNA H=85mm Axial driven tool for internal polygon-making H=85mm Axial angetriebenes Werkzeug fuer interne Facettierung H=85mm		MNZ230.1.10
MODULO MOTORIZZATO ASSIALE BISPORGENTE H=85mm Axial opposite face twin driven tool H=85mm Axial angetriebenes Werkzeug halb vorspringend H=85mm		MNZ240.1.10
MODULO MOTORIZZATO ASSIALE BISPORGENTE 12000 RPM Axial opposite face twin driven tool 12000 rpm Axial angetriebenes Werkzeug halb vorspringend 12000 rpm		MNZ240.1.11

		PAGINA Page Seite
MODULO MOTORIZZATO ASSIALE BISPORGENTE H=100mm Axial opposite face twin driven tool H=100mm Axial angetriebenes Werkzeug halb vorspringend H=100mm		MNZ240.1.20
MODULO MOTORIZZATO ASSIALE 2/4 USCITE IN Y H=85mm Axial multiple 2/4 outlet driven tool in Y H=85mm Axial angetriebenes Mehrspindel-Werkzeug 2/4 Ausgaenge in Y H=85mm		MNZ268.1.00
MODULO MOTORIZZATO ASSIALE 2/4 USCITE IN Y 12000 RPM H=85mm Axial multiple 2/4 outlet driven tool in Y 12000 rpm H=85mm Axial angetriebenes Mehrspindel-Werkzeug 2/4 Ausgaenge in Y 12000 rpm H=85mm		MNZ268.1.01
MODULO MOTORIZZATO ASSIALE 2/4 USCITE IN Y H=100mm Axial multiple 2/4 outlet driven tool in Y H=100mm Axial angetriebenes Mehrspindel-Werkzeug 2/4 Ausgaenge in Y H=100mm		MNZ268.1.10
MODULO MOTORIZZATO ASSIALE 2/4 USCITE IN Y 12000 RPM H=100mm Axial multiple 2/4 outlet driven tool in Y 12000 rpm H=100mm Axial angetriebenes Mehrspindel-Werkzeug 2/4 Ausgaenge in Y 12000 rpm H=100mm		MNZ268.1.11
MODULO MOTORIZZATO ASSIALE 4/8 USCITE Axial multiple 4/8 outlet driven tool Axial angetriebenes Mehrspindel-Werkzeug 4/8 Ausgaenge		MNZ270.1.00
MODULO MOTORIZZATO ORIENTABILE +/-90° H=50mm +/-90° adjustable angle driven tool H=50mm Angetriebenes Werkzeug schwenkbar +/-90° H=50mm		MNZ335.1.00
MODULO MOTORIZZ. ORIENTABILE +/-90° CON NONIO DIGITALE H=50mm +/-90° adjustable angle driven tool with digital display H=50mm Angetriebenes Werkzeug schwenkbar +/-90° mit digital display H=50mm		MNZ335.1.01
MODULO MOTORIZZATO ORIENTABILE +/-90° 12000 RPM H=50mm +/-90° adjustable angle driven tool 12000 rpm H=50mm Angetriebenes Werkzeug schwenkbar +/-90° 12000 rpm H=50mm		MNZ335.1.02
MODULO MOTOR. ORIENT. +/-90° 12000 RPM CON NONIO DIGIT. H=50mm +/-90° adjustable angle driven tool 12000 rpm with digital display H=50mm Angetriebenes Werkzeug schwenkbar +/-90° 12000 rpm mit digital display H=50mm		MNZ335.1.03
MODULO MOTORIZZATO ORIENTABILE +/-90° H=77mm +/-90° adjustable angle driven tool H=77mm Angetriebenes Werkzeug schwenkbar +/-90° H=77mm		MNZ335.1.10
MODULO MOTORIZZ. ORIENTABILE +/-90° CON NONIO DIGITALE H=77mm +/-90° adjustable angle driven tool with digital display H=77mm Angetriebenes Werkzeug schwenkbar +/-90° mit digital display H=77mm		MNZ335.1.11

		PAGINA Page Seite
<p>MODULO MOTORIZZATO ORIENTABILE +/-90° 12000 RPM H=77mm +/-90° adjustable angle driven tool 12000 rpm H=77mm Angetriebenes Werkzeug schwenkbar +/-90° 12000 rpm H=77mm</p>		MNZ335.1.12
<p>MODULO MOTOR. ORIENT. +/-90° 12000 RPM CON NONIO DIGIT. H=77mm +/-90° adjustable angle driven tool 12000 rpm with digital display H=77mm Angetriebenes Werkzeug schwenkbar +/-90° 12000 rpm mit digital display H=77mm</p>		MNZ335.1.13
<p>MODULO MOTORIZZATO ORIENTABILE +/-90° MOLTIPLICATO I=1:2 H=50mm +/-90° adjustable angle driven tool geared-up I=1:2 H=50mm Angetriebenes Werkzeug schwenkbar +/-90° uebersetzt I=1:2 H=50mm</p>		MNZ336.1.00
<p>MODULO MOT. ORIENT. +/-90° MOLTIPL. I=1:2 CON NONIO DIGIT. H=50mm +/-90° adjustable angle driven tool geared-up I=1:2 with digital display H=50mm Angetr. Werkzeug schwenkbar +/-90° uebersetzt I=1:2 mit digital display H=50mm</p>		MNZ336.1.01
<p>MODULO MOTORIZZATO ORIENTABILE +/-90° MOLTIPLICATO I=1:2 H=77mm +/-90° adjustable angle driven tool geared-up I=1:2 H=77mm Angetriebenes Werkzeug schwenkbar +/-90° uebersetzt I=1:2 H=77mm</p>		MNZ336.1.10
<p>MODULO MOT. ORIENT. +/-90° MOLTIPL. I=1:2 CON NONIO DIGIT. H=77mm +/-90° adjustable angle driven tool geared-up I=1:2 with digital display H=77mm Angetr. Werkzeug schwenkbar +/-90° uebersetzt I=1:2 mit digital display H=77mm</p>		MNZ336.1.11
<p>MODULO MOTORIZZATO PORTACREATORE Driven gear hobber Angetriebenes Zahnradwaelzfraes-Werkzeug</p>		MNZ340.1.00
<p>MODULO MOTORIZZATO ASSIALE MTSK PER POWER SKIVING H=98,5mm Axial MTSK driven tool for Power Skiving H=98,5mm Axial MTSK angetriebenes Werkzeug fuer Power Skiving H=98,5mm</p>		MNZ350.1.00.K
<p>MODULO MOTORIZZATO ASSIALE ANGOLARE ±180° Axial adjustable angle ±180° driven tool Axial angetriebenes Werkzeug schwenkbar ±180°</p>		MNZ355.1.00
<p>MODULO MOTORIZZATO PER VITI SENZA FINE Driven tool for worm screws Angetriebenes werkzeug fuer schrauben ohne ende</p>		MNZ359.1.00
<p>MODULO MOTORIZZATO STOZZATORE CORSA 50mm H=85mm Slotting driven tool 50mm stroke H=85mm Keilnutenstossmaschine 50mm Hub H=85mm</p>		MNZ360.1.00
<p>MODULO MOTORIZZATO STOZZATORE CORSA 25mm H=85mm Slotting driven tool 25mm stroke H=85mm Keilnutenstossmaschine 25mm Hub H=85mm</p>		MNZ360.1.01

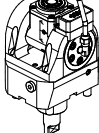
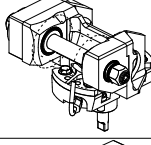
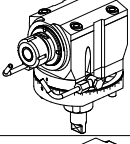
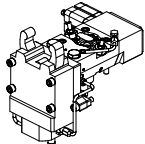
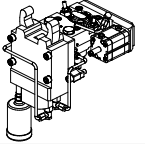
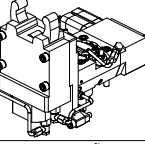
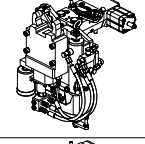
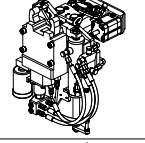
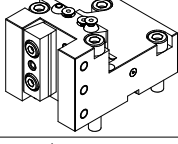
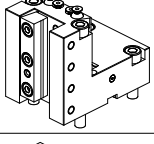
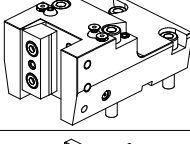
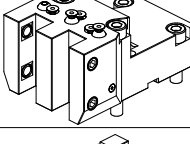
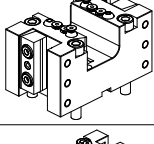
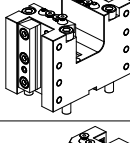
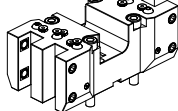
		PAGINA Page Seite
MODULO MOTORIZZATO PER LUNETTA (TAGLIA 1) Steady rest driven tool (Size 1) Angetriebenes Werkzeug fuer Luenette (Groesse 1)		MNZ361.1.00
MODULO MOTORIZZATO PER LUNETTA (TAGLIA 1) Steady rest driven tool (Size 1) Angetriebenes Werkzeug fuer Luenette (Groesse 1)		MNZ361.1.10
MODULO MOTORIZZATO PER LUNETTA RIALZATA (TAGLIA 1) Higher version steady rest driven tool (Size 1) Angetriebenes Werkzeug fuer Luenette, hoehere Version (Groesse 1)		MNZ362.1.00
MODULO MOTORIZZATO PER LUNETTA RETRATTILE (TAGLIA 1) Driven toolholder for sliding steady rest (Size 1) Luenettenwerkzeug zurueck versetzte Version (Groesse 1)		MNZ363.1.00
MODULO MOTORIZZATO PER LUNETTA RETRATTILE (TAGLIA 1) Driven toolholder for sliding steady rest (Size 1) Luenettenwerkzeug zurueck versetzte Version (Groesse 1)		MNZ363.1.10
PORTAUTENSILE RADIALE SINGOLO QD=20mm / QD=3/4" H=70mm Radial single static tool QD=20mm / QD=3/4" H=70mm Radial Single-Werkzeughalter QD=20mm / QD=3/4" H=70mm		MNZ420.1.00
PORTAUTENSILE RADIALE SINGOLO QD=20mm / QD=3/4" H=95mm Radial single static tool QD=20mm / QD=3/4" H=95mm Radial Single-Werkzeughalter QD=20mm / QD=3/4" H=95mm		MNZ420.1.10
PORTAUTENSILE RADIALE SINGOLO QD=25mm / QD=1" H=70mm Radial single static tool QD=25mm / QD=1" H=70mm Radial Single-Werkzeughalter QD=25mm / QD=1" H=70mm		MNZ423.1.00
PORTAUTENSILE RADIALE SOVRAPPOSTO QD=20mm / QD=3/4" H=70mm Radial single side twin static tool QD=20mm / QD=3/4" H=70mm Radial Werkzeughalter ueberlagert QD=20mm / QD=3/4" H=70mm		MNZ440.1.00
PORTAUTENSILE RADIALE DOPPIO QD=20mm / QD=3/4" H=70mm Radial double static tool QD=20mm / QD=3/4" H=70mm Radial Doppel-Werkzeughalter QD=20mm / QD=3/4" H=70mm		MNZ450.1.00
PORTAUTENSILE RADIALE DOPPIO QD=20mm / QD=3/4" H=95mm Radial double static tool QD=20mm / QD=3/4" H=95mm Radial Doppel-Werkzeughalter QD=20mm / QD=3/4" H=95mm		MNZ450.1.10
PORTAUT. RADIALE DOPPIO SOVRAPPOSTO QD=20mm / QD=3/4" H=70mm Radial double side twin static tool QD=20mm / QD=3/4" H=70mm Radial Doppel-Werkzeughalter ueberlagert QD=20mm / QD=3/4" H=70mm		MNZ460.1.00

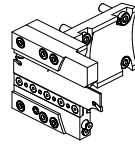
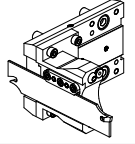
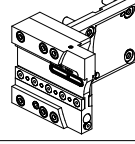
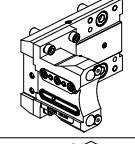
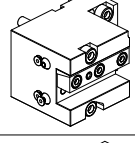
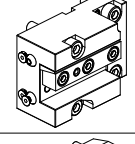
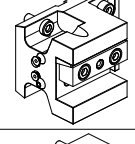
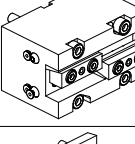
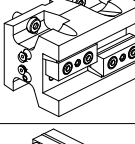
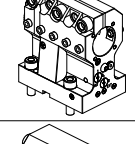
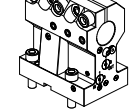
		PAGINA Page Seite
PORTAUTENSILE PER LAMA DOPPIO Radial double blade holder Radial Doppel-Abstechhalter		MNZ520.1.00
PORTAUTENSILE RADIALE PER LAMA Radial blade holder Radial Abstechhalter		MNZ520.1.01
PORTAUTENSILE PER LAMA DOPPIO CON LUBRIFICAZIONE INTERNA Radial double blade holder with internal coolant Radial Doppel-Abstechhalter mit Innenkuehlung		MNZ520.1.04
PORTAUTENSILE RADIALE PER LAMA CON LUBRIFICAZIONE INTERNA Radial blade holder with internal coolant Radial Abstechhalter mit Innenkuehlung		MNZ520.1.05
PORTAUTENSILE ASSIALE SINGOLO QD=20mm / QD=3/4" H=85mm Axial single static tool QD=20mm / QD=3/4" H=85mm Axial Single-Werkzeughalter QD=20mm / QD=3/4" H=85mm		MNZ550.1.00
PORTAUTENSILE ASSIALE SINGOLO QD=20mm / QD=3/4" H=50mm Axial single static tool QD=20mm / QD=3/4" H=50mm Axial Single-Werkzeughalter QD=20mm / QD=3/4" H=50mm		MNZ550.1.10
PORTAUTENSILE ASSIALE SINGOLO QD=25mm Axial single static tool QD=25mm Axial Single-Werkzeughalter QD=25mm		MNZ552.1.00
PORTAUTENSILE ASSIALE DOPPIO QD=20mm / QD=3/4" Axial double static tool QD=20mm / QD=3/4" Axial Doppel-Werkzeughalter QD=20mm / QD=3/4"		MNZ570.1.00
PORTAUTENSILE ASSIALE DOPPIO QD=25mm / QD=1" Axial double static tool QD=25mm / QD=1" Axial Doppel-Werkzeughalter QD=25mm / QD=1"		MNZ572.1.00
PORTAUTENSILE ASSIALE PER BARENO Ø40mm / Ø1 1/2" H=90mm Axial single boring bar holder Ø40mm / Ø1 1/2" H=90mm Axial Bohrhalter Ø40mm / Ø1 1/2" H=90mm		MNZ630.1.20
PORTAUTENSILE ASSIALE PER BARENO Ø40mm H=100mm Axial single boring bar holder Ø40mm H=100mm Axial Bohrhalter Ø40mm H=100mm		MNZ640.1.10
PORTAUTENSILE ASSIALE PER BARENO Ø32mm / Ø1 1/4" H=90mm Axial single boring bar holder Ø32mm / Ø1 1/4" H=90mm Axial Bohrhalter Ø32mm / Ø1 1/4" H=90mm		MNZ650.1.20

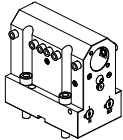
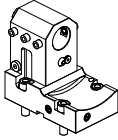
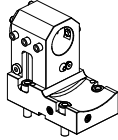
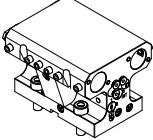
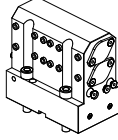
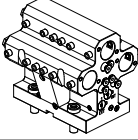
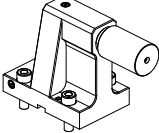
		PAGINA Page Seite
<p>PORTAUTENSILE ASSIALE PER BARENO $\phi 32\text{mm}$ / $\phi 1\ 1/4"$ H=100mm</p> <p>Axial single boring bar holder $\phi 32\text{mm}$ / $\phi 1\ 1/4"$ H=100mm</p> <p>Axial Bohrhalter $\phi 32\text{mm}$ / $\phi 1\ 1/4"$ H=100mm</p>		MNZ660.1.10
<p>PORTAUTENSILE ASSIALE ARRETRATO PER BARENO $\phi 32\text{mm}$ H=100mm</p> <p>Axial single rear set boring bar holder $\phi 32\text{mm}$ H=100mm</p> <p>Axial Bohrhalter zurueckversetzt $\phi 32\text{ mm}$ H=100mm</p>		MNZ845.1.10
<p>PORTAUTENSILE ASSIALE ARRETRATO PER BARENO $\phi 40\text{mm}$ H=100mm</p> <p>Axial single rear set boring bar holder $\phi 40\text{mm}$ H=100mm</p> <p>Axial Bohrhalter zurueckversetzt $\phi 40\text{mm}$ H=100mm</p>		MNZ845.1.20
<p>PORTAUT. ASSIALE PER BARENO 2+2 POSIZIONI $\phi 25\text{mm}$ / $\phi 1"$ / $\phi 20\text{mm}$ / $\phi 3/4"$</p> <p>Axial 2+2 position boring bar holder $\phi 25\text{mm}$ / $\phi 1"$ / $\phi 20\text{mm}$ / $\phi 3/4"$</p> <p>Axial Bohrhalter 2+2 Positionen $\phi 25\text{mm}$ / $\phi 1"$ / $\phi 20\text{mm}$ / $\phi 3/4"$</p>		MNZ864.1.00
<p>PORTAUT. ASSIALE PER BARENO 2+2 POSIZIONI $\phi 25\text{mm}$ / $\phi 1"$</p> <p>Axial 2+2 position boring bar holder $\phi 25\text{mm}$ / $\phi 1"$</p> <p>Axial Bohrhalter 2+2 Positionen $\phi 25\text{mm}$ / $\phi 1"$</p>		MNZ874.1.00
<p>PORTAUT. ASSIALE PER BARENO 3+3 POSIZIONI $\phi 25\text{mm}$ / $\phi 1"$ / $\phi 20\text{mm}$ / $\phi 3/4"$</p> <p>Axial 3+3 position boring bar holder $\phi 25\text{mm}$ / $\phi 1"$ / $\phi 20\text{mm}$ / $\phi 3/4"$</p> <p>Axial Bohrhalter 3+3 Positionen $\phi 25\text{mm}$ / $\phi 1"$ / $\phi 20\text{mm}$ / $\phi 3/4"$</p>		MNZ914.1.00
<p>CONTROPUNTA PER CONTROMANDRINO</p> <p>Tailstock for subspindle</p> <p>Gegenspintz fuer Gegenspindel</p>		MNZ950.1.00

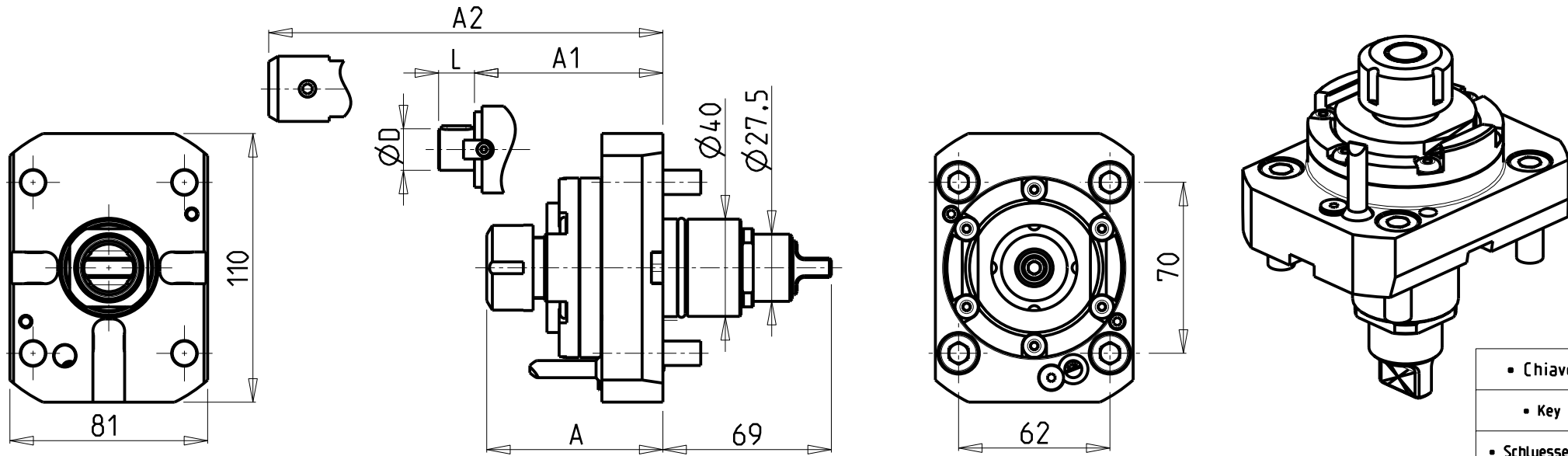

- Chiave inclusa
- Key included
- Schluessel inbegriffen

Cod. MT	Cod. MORI-SEIKI	Mandrino Spindle Spindel	I	RPM	Coppia Max Max Torque Max Drehmoment	Lubrificazione int. Coolant through Innenkuehlung	Lubrificazione est. Ext. coolant Aussenkuehlung	A	A1	A2	D	L	CHIAVI NON INCLUSE Keys not included Schluessel nicht einbegriffen	
MNZ0020120	T32254	ER20	1:1	6000	40Nm		X	72.16	-	-	-	-	MNZ0410005	CHSTER20
MNZ0020125	T32274	ER25	1:1	6000	40Nm		X	73.16	-	-	-	-	MNZ0410005	CHSTER25
MNZ0020132	-	ER32	1:1	6000	40Nm		X	76.16	-	-	-	-	MNZ0410005	CHSTER32
MNZ0020225	-	ER25	1:1	6000	40Nm	P=30bar	X	81.66	-	-	-	-	MNZ0410005	CHSTER25
MNZ0020232	-	ER32	1:1	6000	40Nm	P=30bar	X	86.16	-	-	-	-	MNZ0410005	CHSTER32
MNZ0020416	-	Ø16x17	1:1	6000	40Nm		X	-	54.5	-	16	17	MNZ0410005	CH_VTCROCE_M08
MNZ0020422	-	Ø22x19	1:1	6000	40Nm		X	-	54.5	-	22	19	MNZ0410005	CH_VTCROCE_M10
MNZ0020419	-	Ø3/4"x3/4"	1:1	6000	40Nm		X	-	54.5	-	3/4"	3/4"	MNZ0410005	CH_VTCROCE_M08
MNZ0020308	-	WELDON 8	1:1	6000	40Nm		X	-	-	72.5	-	-		
MNZ0020310	-	WELDON 10	1:1	6000	40Nm		X	-	-	74.5	-	-		
MNZ0020312	-	WELDON 12	1:1	6000	40Nm		X	-	-	77	-	-		
MNZ0020316	-	WELDON 16	1:1	6000	40Nm		X	-	-	79.5	-	-		

DMG-MORI
 NZ1500/2000 - NZX1500/2000 - NT3000 SERIE - NL1500/2000/2500 20 STAZ. - NLX1500/2000/2500 20 STAZ.
 NT1000/2000 - NTX1000/2000 - NTX1000/2000/2500/3000 2ND GEN. 12ST. - DURATURN 2050MC/2550MC - NRX2000 - ALX1500/2000/2500

MODULO MOTORIZZATO RADIALE
 Radial driven tool
 Radial angetriebenes Werkzeug

Subject to change without notice.

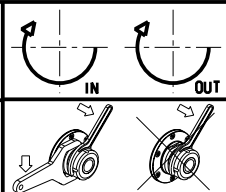

M.T. srl
 Via Casino Albini 480
 Tel. 0541/956034-957884
 Fax 0541/956341
 47842 S. GIOVANNI IN M. (RN)
 e-mail: mtma@mtmarchetti.com
 http://www.mtmarchetti.com

PRODUZIONE MODULI ROTANTI



PAGINA MNZ010-1-00

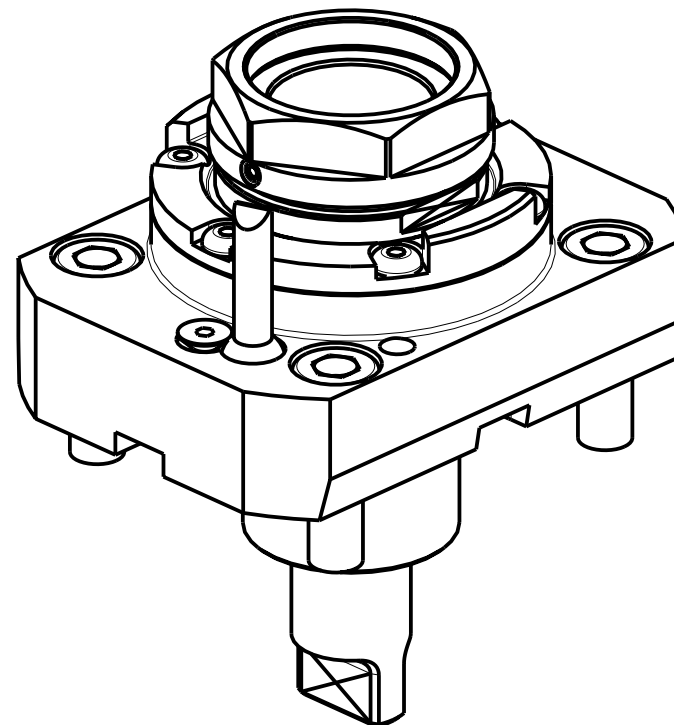
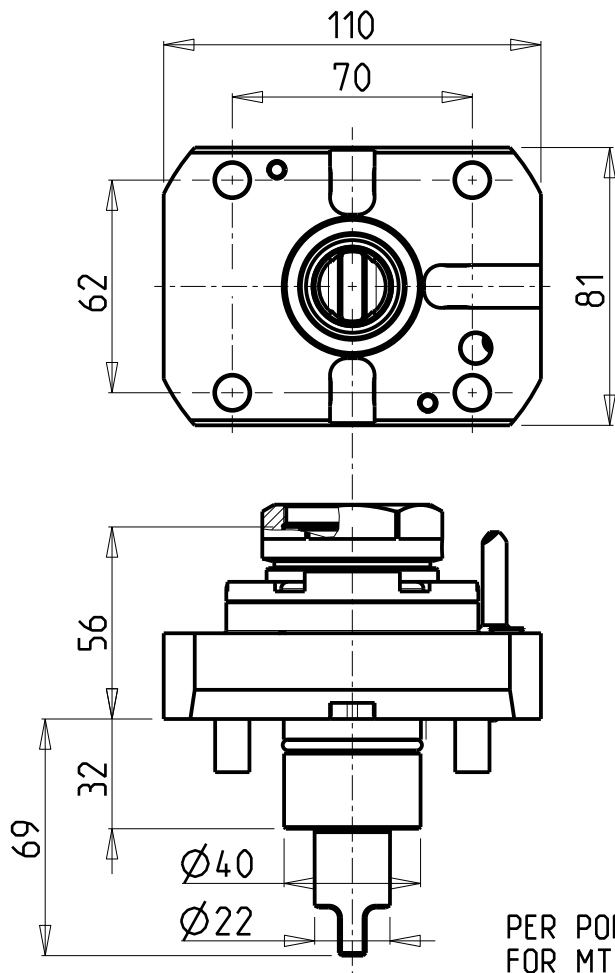

PER PORTAUTENSILI MODULARI MTSK-40 VEDI PAG. TBL300-1-40
 FOR MTSK-40 QUIK CHANGE TOOLHOLDERS CLAMPINGS SEE PAGE TBL300-1-40
 FUER MTSK-40 MODULARE WERKZEUGAUFNAHMEN SIEHE SEITE TBL300-1-40

- Chiave inclusa
- Key included
- Schlüssel inbegriffen

Cod. MT	Mandrino Spindle Spindel	I	RPM	Coppia Max Max Torque Max Drehmoment	Lubrificazione est. Ext. coolant Aussenkuehlung	CHIAVI NON INCLUSE Keys not included Schluessel nicht einbegriffen	
MNZ0410140	MTSK-40	1:1	6000	40Nm	X	CHUB46	MNZ0410005 *

DMG-MORI

NZ1500/2000 - NZX1500/2000 - NT3000 SERIE - NL1500/2000/2500 20 STAZ. - NLX1500/2000/2500 20 STAZ.
 NT1000/2000 - NTX1000/2000 - NTX1000/2000/2500/3000 2ND GEN. 12ST. - DURATURN 2050MC/2550MC - NRX2000 - ALX1500/2000/2500

MODULO MOTORIZZATO RADIALE MTSK

Radial MTSK driven tool

Radial MTSK angetriebenes Werkzeug

Subject to change without notice.

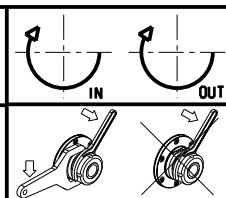

M.T. srl

Via Casino Albini 480
 Tel. 0541/956034-957884
 Fax 0541/956341

47842 S. GIOVANNI IN M. (RN)
 e-mail: mtma@mtmarchetti.com
 http://www.mtmarchetti.com

PRODUZIONE MODULI ROTANTI



PAGINA MNZ010-1-00-K

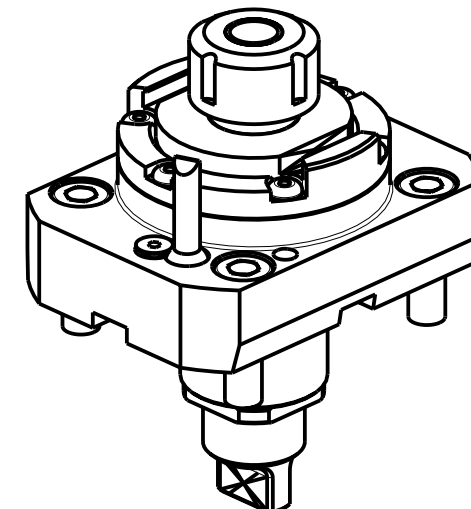
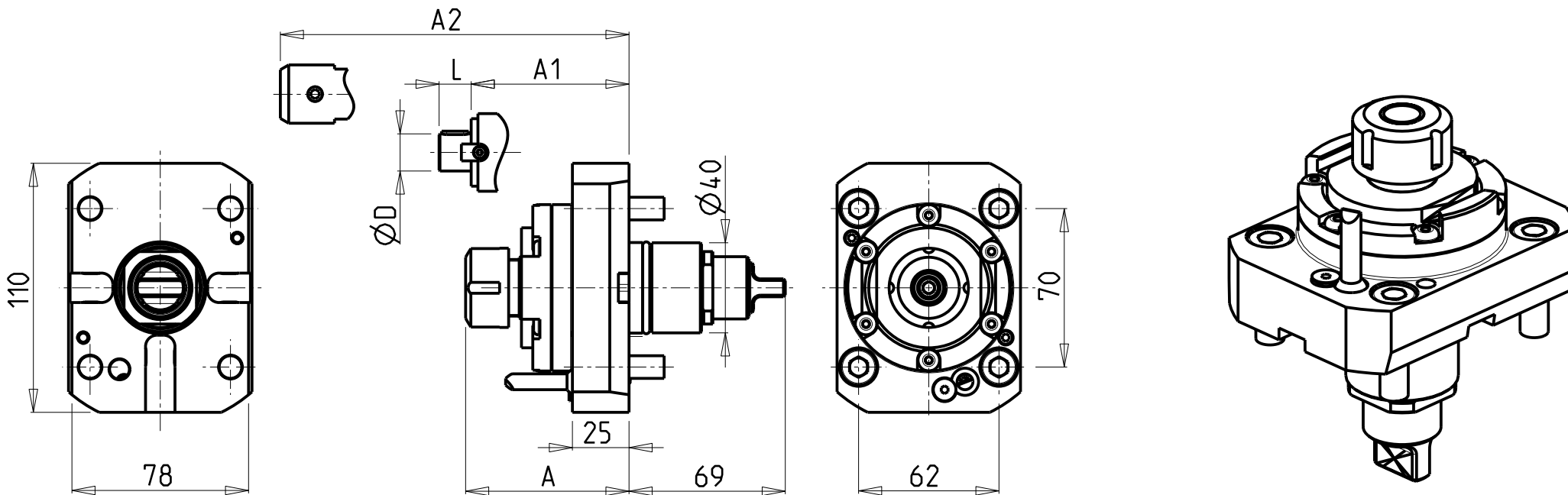

- Chiave inclusa
- Key included
- Schlüssel inbegriffen

Cod. MT	Mandrino Spindle Spindel	I	RPM	Coppia Max Max Torque Max Drehmoment	Lubrificazione est. Ext. coolant Ausseukuehlung	A	A1	A2	D	L	CHIAVI NON INCLUSE Keys not included Schlüssel nicht einbegriffen	
MNZ0440120	ER20	1:1	12000	40Nm	X	72.16	-	-	-	-	MNZ0410005	CHSTER20
MNZ0440125	ER25	1:1	12000	40Nm	X	73.16	-	-	-	-	MNZ0410005	CHSTER25
MNZ0440132	ER32	1:1	12000	40Nm	X	76.16	-	-	-	-	MNZ0410005	CHSTER32
MNZ0440416	Ø16x17	1:1	12000	40Nm	X	-	54.5	-	16	17	MNZ0410005	CH_VTCROCE_M08
MNZ0440422	Ø22x19	1:1	12000	40Nm	X	-	54.5	-	22	19	MNZ0410005	CH_VTCROCE_M10
MNZ0440419	Ø3/4"x3/4"	1:1	12000	40Nm	X	-	54.5	-	3/4"	3/4"	MNZ0410005	CH_VTCROCE_M08
MNZ0440308	WELDON 8	1:1	12000	40Nm	X	-	-	72.5	-	-	-	-
MNZ0440310	WELDON 10	1:1	12000	40Nm	X	-	-	74.5	-	-	-	-
MNZ0440312	WELDON 12	1:1	12000	40Nm	X	-	-	77	-	-	-	-
MNZ0440316	WELDON 16	1:1	12000	40Nm	X	-	-	79.5	-	-	-	-

DMG-MORI
 NZ1500/2000 - NZX1500/2000 - NL1500/2000/2500 20 STAZ. - NLX1500/2000/2500 20 STAZ.
 NTX1000/2000 - NTX1000/2000/2500/3000 2ND GEN. 12ST. - NRX2000

MODULO MOTORIZZATO RADIALE 12000 RPM
 Radial driven tool 12000 rpm
 Radial angetriebenes Werkzeug 12000 rpm

Subject to change without notice.

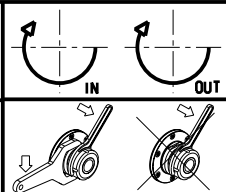

M.T. srl
 Via Casino Albini 480
 Tel. 0541/956034-957884
 Fax 0541/956341
 47842 S. GIOVANNI IN M. (RN)
 e-mail: mtma@mtmarchetti.com
 http://www.mtmarchetti.com

PRODUZIONE MODULI ROTANTI



PAGINA MNZ010-1-01

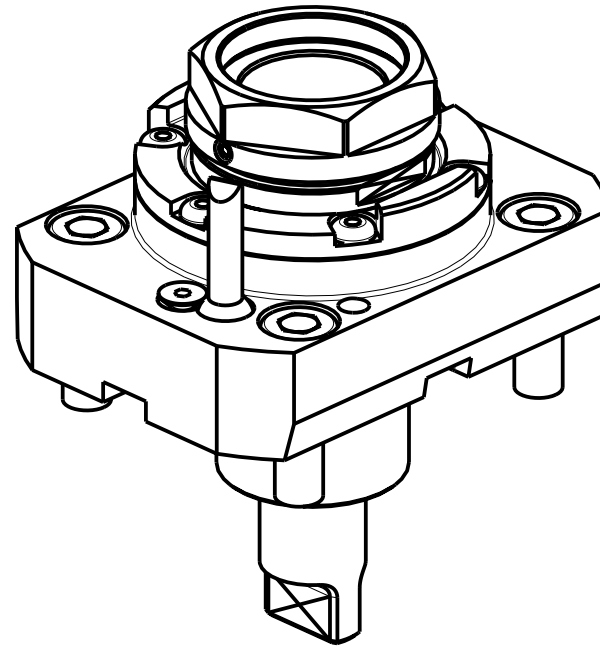
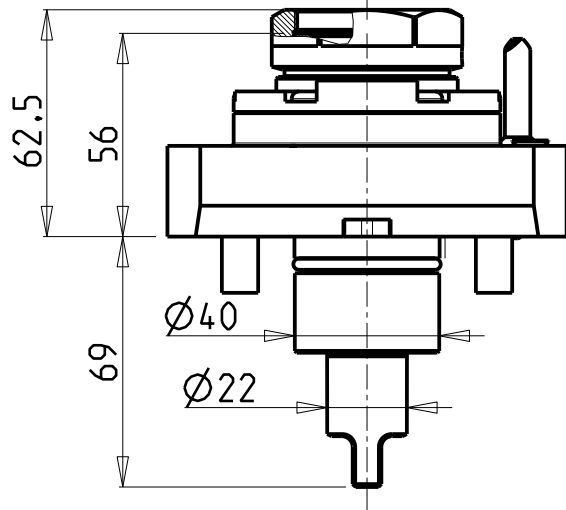
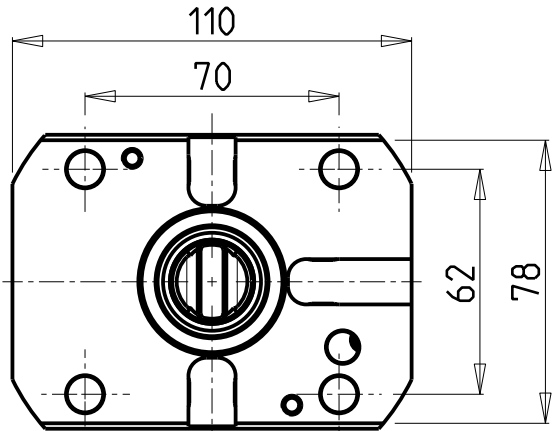

PER PORTAUTENSILI MODULARI MTSK-40 VEDI PAG. TBL300-1-40
 FOR MTSK-40 QUIK CHANGE TOOLHOLDERS CLAMPINGS SEE PAGE TBL300-1-40
 FUER MTSK-40 MODULARE WERKZEUGAUFNAHMEN SIEHE SEITE TBL300-1-40

Cod. MT	Mandrino Spindle Spindel	I	RPM	Coppia Max Max Torque Max Drehmoment	Lubrificazione est. Ext. coolant Aussenkuehlung	CHIAVI NON INCLUSE Keys not included Schlüssel nicht einbegriffen	
MNZ0450140	MTSK-40	1:1	12000	40Nm	X	CHUB46	MNZ0410005 ▪

- Chiave inclusa
- Key included
- Schlüssel inbegriffen

DMG-MORI
 NZ1500/2000 - NZX1500/2000 - NL1500/2000/2500 20 STAZ. - NLX1500/2000/2500 20 STAZ.
 NTX1000/2000 - NTX1000/2000/2500/3000 2ND GEN. 12ST. - NRX2000

MODULO MOTORIZZATO RADIALE MTSK 12000 RPM
 Radial MTSK driven tool 12000 rpm
 Radial MTSK angetriebenes Werkzeug 12000 rpm

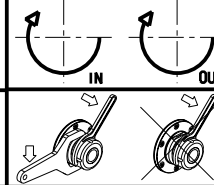

M.T. srl
 Via Casino Albini 480
 Tel. 0541/956034-957884
 Fax 0541/956341
 47842 S. GIOVANNI IN M. (RN)
 e-mail: mtma@mtmarchetti.com
 http://www.mtmarchetti.com

PRODUZIONE MODULI ROTANTI



PAGINA MNZ010-1-01-K

Subject to change without notice.

10/2018

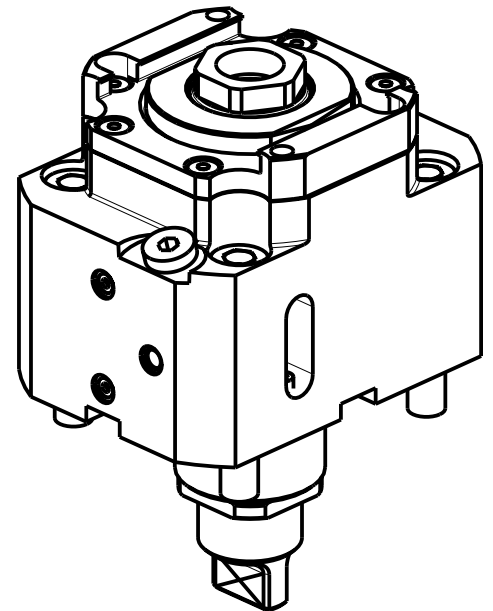
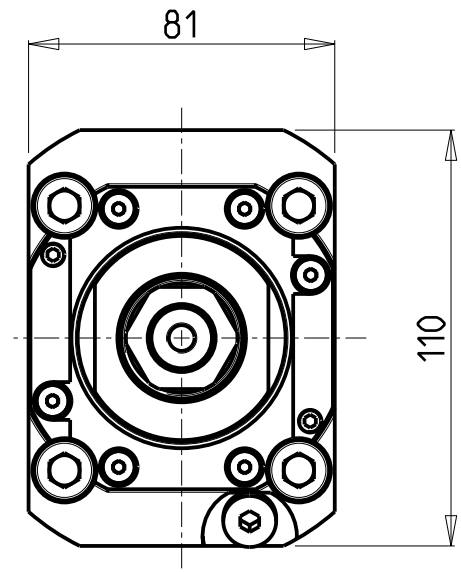
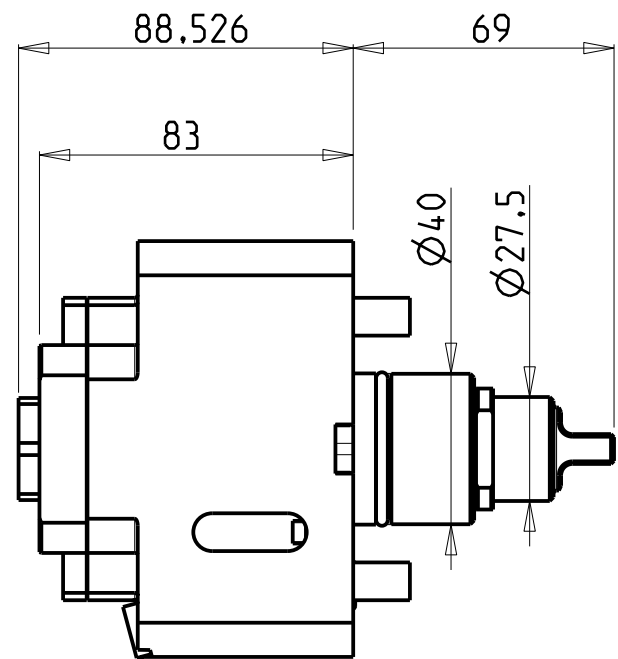
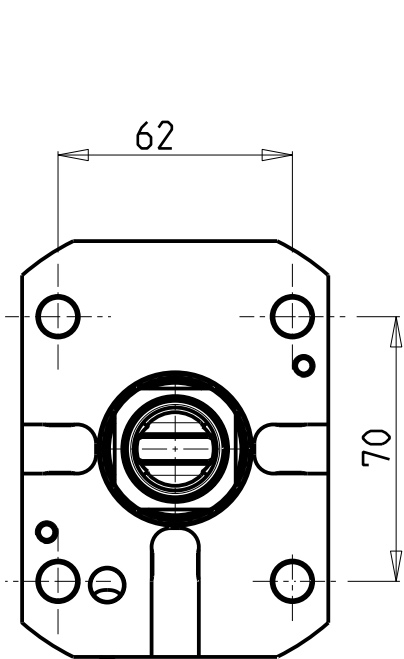

- Chiave inclusa
- Key included
- Schluessel inbegriffen

Cod. MT	Cod. MORI-SEIKI	Mandrino Spindle Spindel	I	RPM	Coppia Max Max Torque Max Drehmoment	Lubrificazione int. Coolant through Innenkuehlung	Lubrificazione est. Ext. coolant Aussenkuehlung	CHIAVI NON INCLUSE Keys not included Schluessel nicht inbegriffen	
MNZ0340125	-	ERA25	1:1	6000	40Nm	P=80bar	X	MNZ0410005 ▪	CHUB27

DMG-MORI
 NZ1500/2000 - NZX1500/2000 - NT3000 SERIE - NL1500/2000/2500 20 STAZ. - NLX1500/2000/2500 20 STAZ.
 NT1000/2000 - NTX1000/2000 - NTX1000/2000/2500/3000 2ND GEN. 12ST. - DURATURN 2050MC/2550MC - NRX2000 - ALX1500/2000/2500

MODULO MOTORIZZATO RADIALE ALTA PRESSIONE
 Radial driven tool high pressure
 Radial angetriebenes Werkzeug hochdruck

Subject to change without notice.

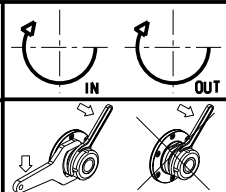

M.T. srl
 Via Casino Albini 480
 Tel. 0541/956034-957884
 Fax 0541/956341
 47842 S. GIOVANNI IN M. (RN)
 e-mail: mtma@tmarchetti.com
 http://www.tmmarchetti.com

PRODUZIONE MODULI ROTANTI



PAGINA MNZ010-1-20

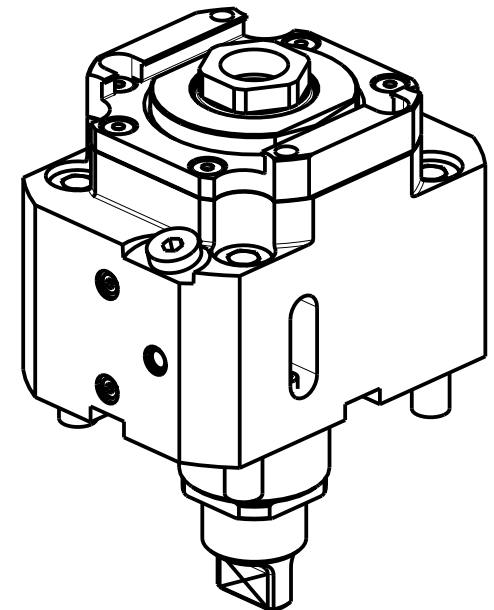
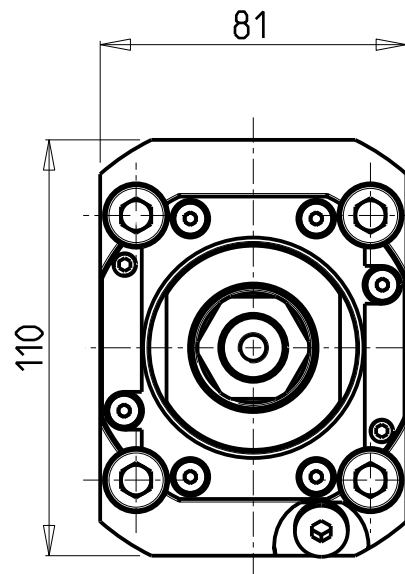
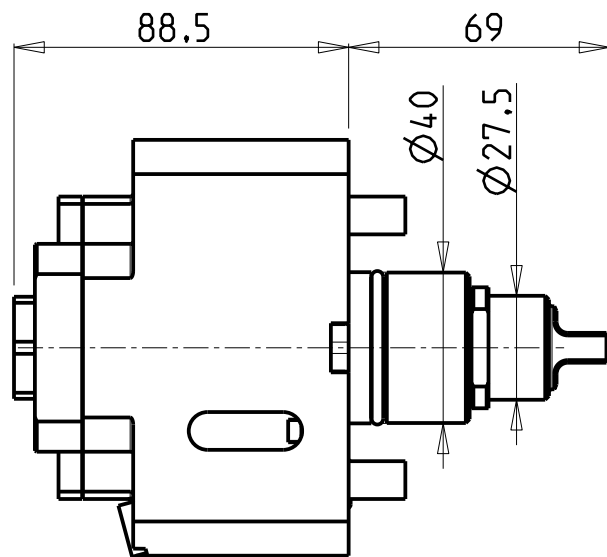
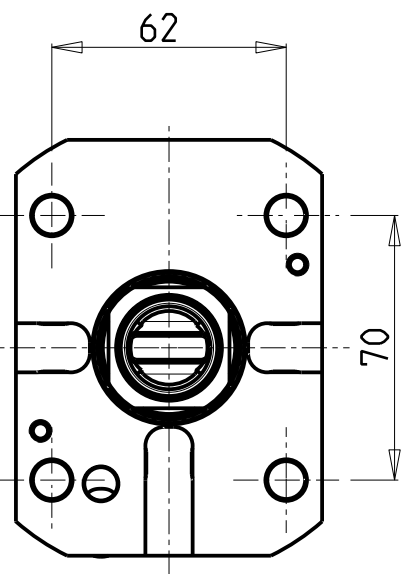

Cod. MT	Cod. MORI-SEIKI	Mandrino Spindle Spindel	I	RPM	Coppia Max Max Torque Max Drehmoment	Lubrificazione int. Coolant through Innenkuehlung	Lubrificazione est. Ext. coolant Aussenkuehlung	CHIAVI NON INCLUSE Keys not included Schlüssel nicht einbegriffen	
MNZ0460125	-	ERA25	1:1	12000	40Nm	P=30bar	X	C HUB27	MNZ0410005 *

- Chiave inclusa
- Key included
- Schlüssel inbegriffen

DMG-MORI
 NZ1500/2000 - NZX1500/2000 - NL1500/2000/2500 20 STAZ. - NLX1500/2000/2500 20 STAZ.
 NTX1000/2000 - NTX1000/2000/2500/3000 2ND GEN. 12ST. - NRX2000

MODULO MOTORIZZATO RADIALE 12000 RPM
 Radial driven tool 12000 rpm
 Radial angetriebenes Werkzeug 12000 rpm

Subject to change without notice.

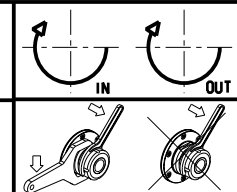

M.T. srl
 Via Casino Albini 480
 Tel. 0541/956034-957884
 Fax 0541/956341
 47842 S. GIOVANNI IN M. (RN)
 e-mail: mtma@mtmarchetti.com
 http://www.mtmarchetti.com

PRODUZIONE MODULI ROTANTI



PAGINA MNZ010-1-21

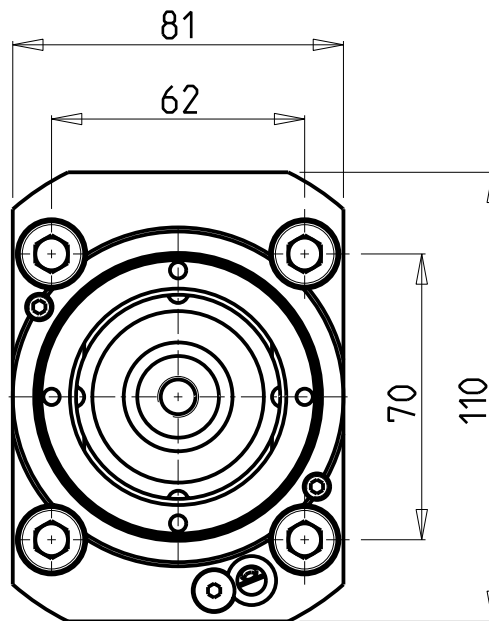
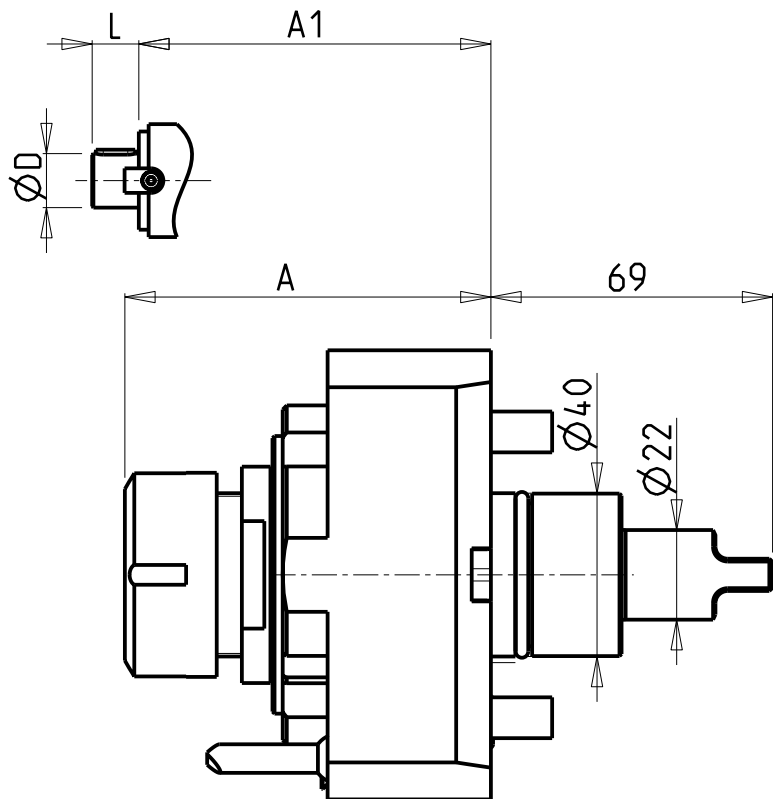

CUSCINETTI MAGGIORATI PER LAVORAZIONI PESANTI

Reinforced bearings for
heavy machining

Vergroesserte lager fuer
schwerere Bearbeitungen

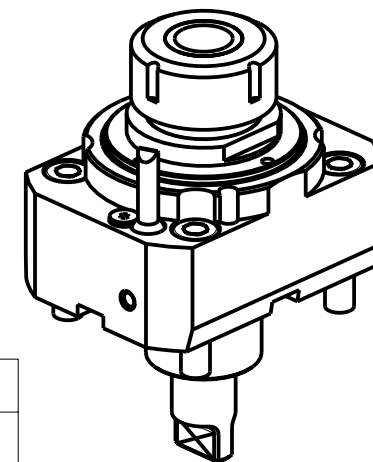

- Chiave inclusa
- Key included
- Schluessel inbegriffen

Cod. MT	Mandrino Spindle Spindel	I	RPM	Coppia Max Max Torque Max Drehmoment	Lubrificazione int. Coolant through Innenkuehlung	Lubrificazione est. Ext. coolant Aussenkuehlung	A	A1	D	L	CHIAVI NON INCLUSE Keys not included Schluessel nicht einbegriffen		
MNZ0360132	ER32	1:1	6000	40Nm		X	89.66	-	-	-	CHSTER32	CHUB46	
MNZ0360440	ERA40	1:1	6000	40Nm	P=30bar	X	83.5	-	-	-	CHTAER40ZC	CHUB55	CHUB36
MNZ0360516	Ø16x17	1:1	6000	40Nm		X	-	68	16	17	CH_VTCROCE_M08	CHUB46	
MNZ0360519	Ø3/4"x3/4"	1:1	6000	40Nm		X	-	68	3/4"	3/4"	CH_VTCROCE_M08	CHUB46	
MNZ0360522	Ø22x19	1:1	6000	40Nm		X	-	68	22	19	CH_VTCROCE_M10	CHUB46	

DMG-MORI

NZ1500/2000 - NZX1500/2000 - NT3000 SERIE - NL1500/2000/2500 20 STAZ. - NLX1500/2000/2500 20 STAZ.
NT1000/2000 - NTX1000/2000 - NTX1000/2000/2500/3000 2ND GEN. 12ST. - DURATURN 2050MC/2550MC - NRX2000 - ALX1500/2000/2500

MODULO MOTORIZZATO RADIALE MAGGIORATO

Radial reinforced driven tool

Radial angetriebenes Werkzeug vergroessert

Subject to change without notice.

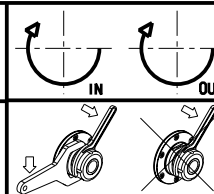

M.T. srl

Via Casino Albini 480
Tel. 0541/956034-957884
Fax 0541/956341
47842 S. GIOVANNI IN M. (RN)
e-mail: mtma@mtmarchetti.com
http://www.mtmarchetti.com

PRODUZIONE MODULI ROTANTI



PAGINA MNZ020-1-00

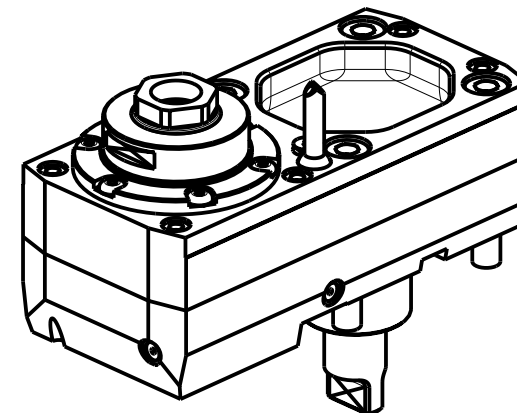
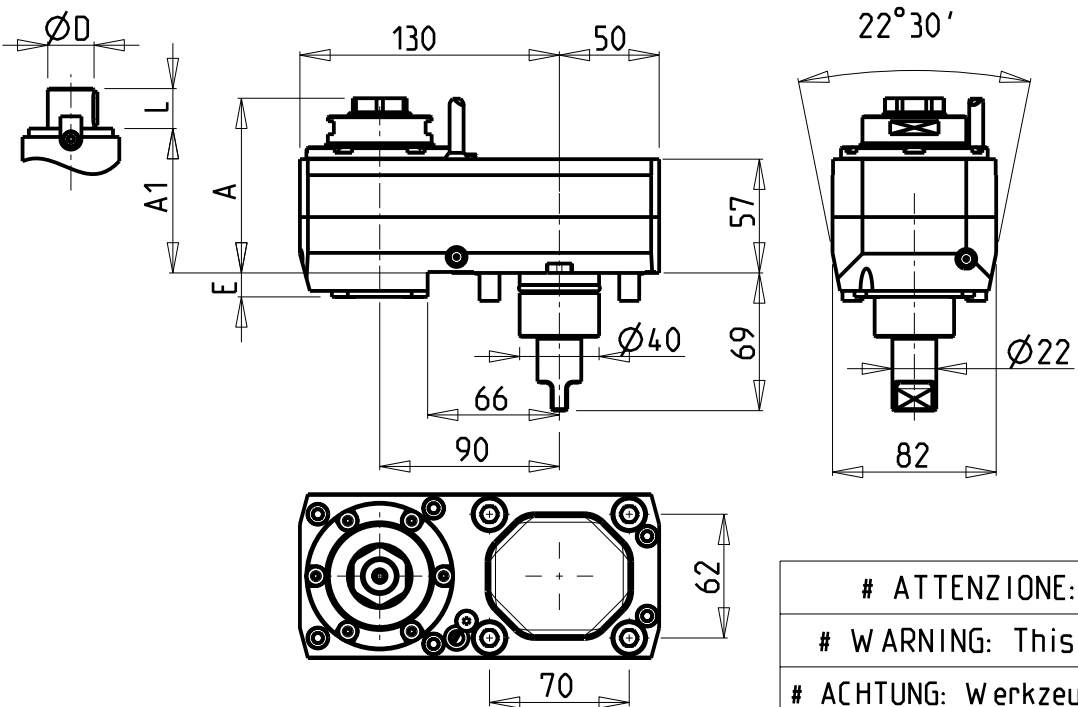

ATTENZIONE: Non si monta su macchine NT3000 SERIE
 # WARNING: This tool can not be mounted on NT3000 SERIES
 # ACHTUNG: Werkzeug darf nicht auf NT3000 SERIEN montiert werden

- Chiave inclusa
- Key included
- Schluessel inbegriffen

Cod. MT	Mandrino Spindel Spindel	I	RPM	Coppia Max Max Torque Max Drehmoment	Reversibile lato mandrino/contromandrino Reversible sub/main spindle side Umkehrbare Spindel-seite/ Gegenspindel-seite	Lu-br.interna Coolant through Innenkuehlung	Lu-br.esterna Ext. coolant Aus-senkuehlung	A	A1	D	L	E	CHIAVI NON INCLUDE Keys not included Schluessel nicht einbegriffen	
MNZ0060220	ER A 20	1:1	6000	40Nm	X		X	81.73	-	-	-	12	CHUB46	CHUB22
MNZ0060225	ER A 25	1:1	6000	40Nm	X		X	87.53	-	-	-	12	CHUB46	CHUB27
MNZ0060232	ER A 32	1:1	6000	40Nm	X		X	95.03	-	-	-	12	CHUB46	CHUB32
MNZ0060425	ER A 25	1:1	6000	40Nm	X	P=70bar	X	87.53	-	-	-	22	CHUB46	CHUB27
MNZ0060432	ER A 32	1:1	6000	40Nm	X	P=70bar	X	95.03	-	-	-	22	CHUB46	CHUB32
MNZ0060216	Ø16x17	1:1	6000	40Nm	X		X	-	75.5	16	17	12	CHUB46	CH_VTCROCE_M08 •
MNZ0060222	Ø22x19	1:1	6000	40Nm	X		X	-	75.5	22	19	12	CHUB46	CH_VTCROCE_M10 •
MNZ0060219	Ø3/4"x3/4"	1:1	6000	40Nm	X		X	-	75.5	3/4"	3/4"	12	CHUB46	CH_VTCROCE_M08 •

DMG-MORI
 NZ1500/2000 - NZX1500/2000 - NT3000 SERIE - NL1500/2000/2500 20 STAZ. - NLX1500/2000/2500 20 STAZ.
 NT1000/2000 - NTX1000/2000 - NTX1000/2000/2500/3000 2ND GEN. 12ST. - DURATURN 2050MC/2550MC - NRX2000 - ALX1500/2000/2500

MODULO MOTORIZZATO RADIALE DISASSATO IN Z 90mm
 Radial driven tool re-directed in Z by 90mm
 Radial angetriebenes Werkzeug achsversetzt in Z um 90mm

Subject to change without notice.

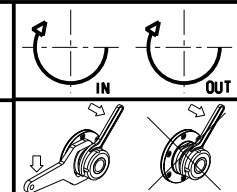

M.T. srl
 Via Casino Albini 480
 Tel. 0541/956034-957884
 Fax 0541/956341
 47842 S. GIOVANNI IN M. (RN)
 e-mail: mtma@mtmarchetti.com
 http://www.mtmarchetti.com

PRODUZIONE MODULI ROTANTI

PAGINA MNZ030-1-10

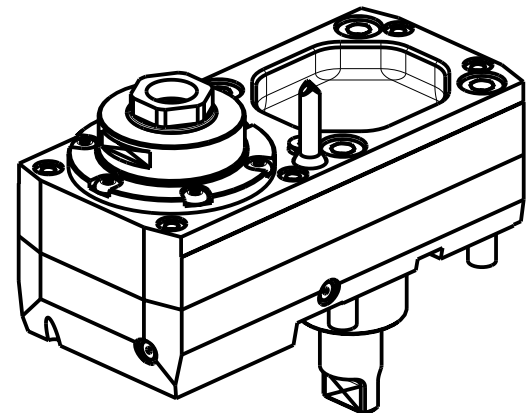
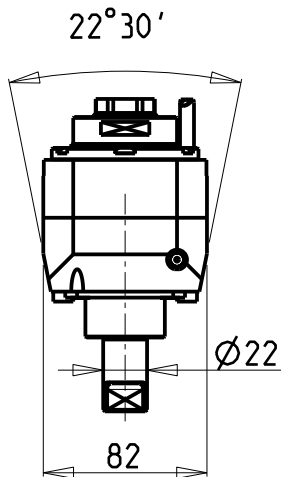
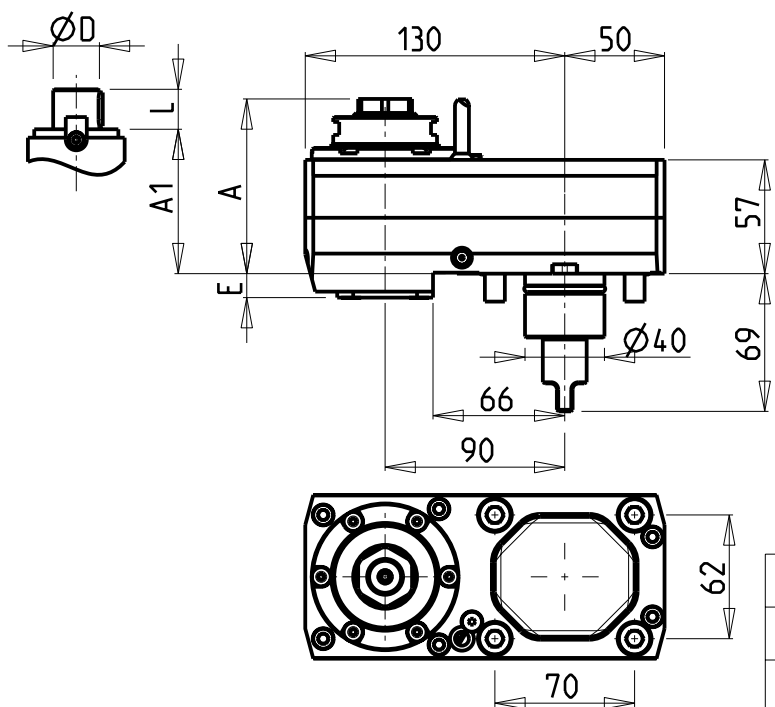

ATTENZIONE: Non si monta su macchine NT3000 SERIE
 # WARNING: This tool can not be mounted on NT3000 SERIES
 # ACHTUNG: Werkzeug darf nicht auf NT3000 SERIEN montiert werden

- Chiave inclusa
- Key included
- Schluessel inbegriffen

Cod. MT	Mandrino Spindel	I	RPM	Coppia Max Max Torque Max Drehmoment	Reversibile lato mandrino/contromandrino Reversible sub/main spindle side Umkehrbare Spindel-seite/ Gegenspindel-seite	Lubr.interna Coolant through Innenkuehlung	Lubr.esterna Ext. coolant Aussenkuehlung	A	A1	D	L	E	CHIAVI NON INCLUDE Keys not included Schluessel nicht einbegriffen	
													CHUB46	CHUB27
MNZ0060125	ER A 25	2:1	3000	60Nm	X		X	87.53	-	-	-	12	CHUB46	CHUB27
MNZ0060132	ER A 32	2:1	3000	60Nm	X		X	95.03	-	-	-	12	CHUB46	CHUB32
MNZ0060525	ER A 25	2:1	3000	60Nm	X	P=70bar	X	87.53	-	-	-	22	CHUB46	CHUB27
MNZ0060532	ER A 32	2:1	3000	60Nm	X	P=70bar	X	95.03	-	-	-	22	CHUB46	CHUB32
MNZ0060116	Ø16x17	2:1	3000	60Nm	X		X	-	75.5	16	17	12	CHUB46	CH_VTCROCE_M08 *
MNZ0060122	Ø22x19	2:1	3000	60Nm	X		X	-	75.5	22	19	12	CHUB46	CH_VTCROCE_M10 *
MNZ0060119	Ø3/4"x3/4"	2:1	3000	60Nm	X		X	-	75.5	3/4"	3/4"	12	CHUB46	CH_VTCROCE_M08 *

DMG-MORI
 NZ1500/2000 - NZX1500/2000 - NT3000 SERIE - NL1500/2000/2500 20 STAZ. - NLX1500/2000/2500 20 STAZ.
 NT1000/2000 - NTX1000/2000 - NTX1000/2000/2500/3000 2ND GEN. 12ST. - DURATURN 2050MC/2550MC - NRX2000 - ALX1500/2000/2500

MODULO MOTORIZZATO RADIALE RIDOTTO I=2:1 DISASSATO IN Z 90mm
 Radial geared-down I=2:1 driven tool re-directed in Z by 90mm
 Radial angetriebenes Werkzeug untersetzt I=2:1 achsversetzt in Z um 90mm

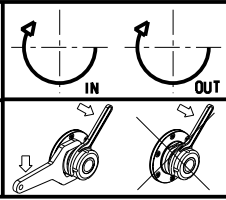

M.T. srl
 Via Casino Albini 480
 Tel. 0541/956034-957884
 Fax 0541/956341
 47842 S. GIOVANNI IN M. (RN)
 e-mail: mtma@mtmarchetti.com
 http://www.mtmarchetti.com

PRODUZIONE MODULI ROTANTI

 PAGINA MNZ030-1-20

Subject to change without notice.

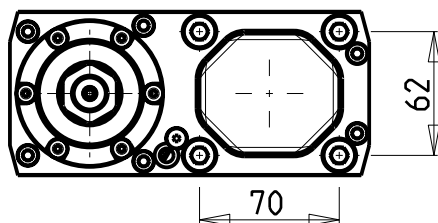
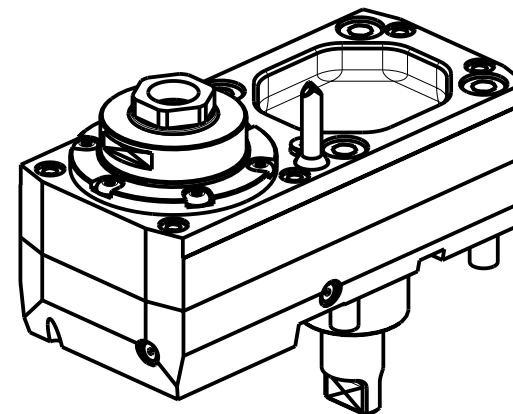
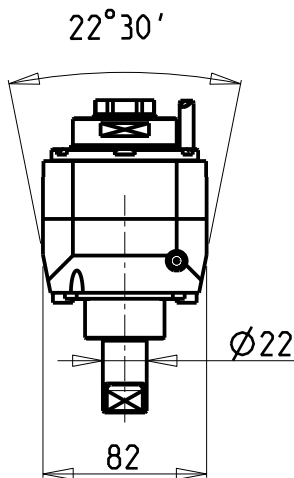
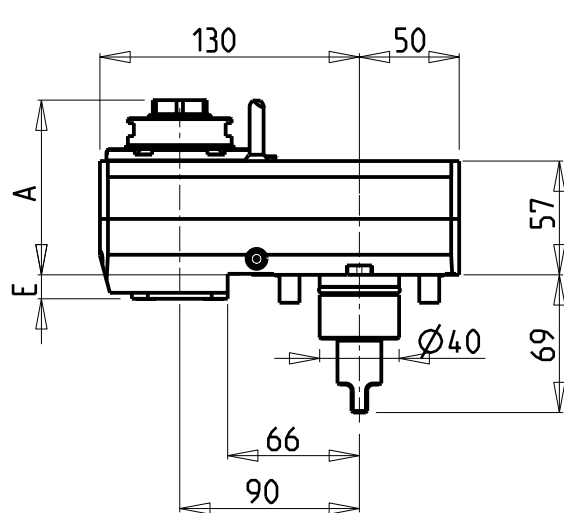

ATTENZIONE: Non si monta su macchine NT3000 SERIE

WARNING: This tool can not be mounted on NT3000 SERIES

ACHTUNG: Werkzeug darf nicht auf NT3000 SERIEN montiert werden

#	Cod. MT	Mandrino Spindle Spindel	I	RPM	Coppia Max Max Torque Max Drehmoment	Reversibile lato mandrino/contromandrino Reversible sub/main spindle side Umkehrbare Spindel-seite/ Gegenspindel-seite	Lubr.interna Coolant through Innenkuehlung	Lubr.esterna Ext. coolant Aussenkuehlung	A	E	CHIAVI NON INCLUSE Keys not included Schluessel nicht einbegriffen	
	MNZ0060320	ER A 20	1:2	12000	30Nm	X		X	88.73	12	CHUB46	CHUB22
	MNZ0060620	ER A 20	1:2	12000	30Nm	X	P=70bar	X	88.73	22	CHUB46	CHUB22
	MNZ0060325	ER A 25	1:2	12000	30Nm	X		X	94.53	12	CHUB46	CHUB27

DMG-MORI

NZ1500/2000 - NZX1500/2000 - NT3000 SERIE - NL1500/2000/2500 20 STAZ. - NLX1500/2000/2500 20 STAZ.
NT1000/2000 - NTX1000/2000 - NTX1000/2000/2500/3000 2ND GEN. 12ST. - DURATURN 2050MC/2550MC - NRX2000 - ALX1500/2000/2500

MODULO MOTORIZZATO RADIALE Moltiplicato I=1:2 DISASSATO IN Z 90mm

Radial geared-up I=1:2 driven tool re-directed in Z by 90mm

Radial angetriebenes Werkzeug uebersetzt I=1:2 achsversetzt in Z um 90mm

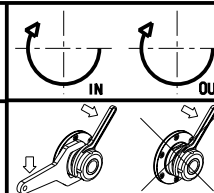

M.T. srl

Via Casino Albini 480
Tel. 0541/956034-957884
Fax 0541/956341

47842 S. GIOVANNI IN M. (RN)
e-mail: mtma@mtmarchetti.com
http://www.mtmarchetti.com

PRODUZIONE MODULI ROTANTI



PAGINA MNZ030-1-30

Subject to change without notice.

10/2018

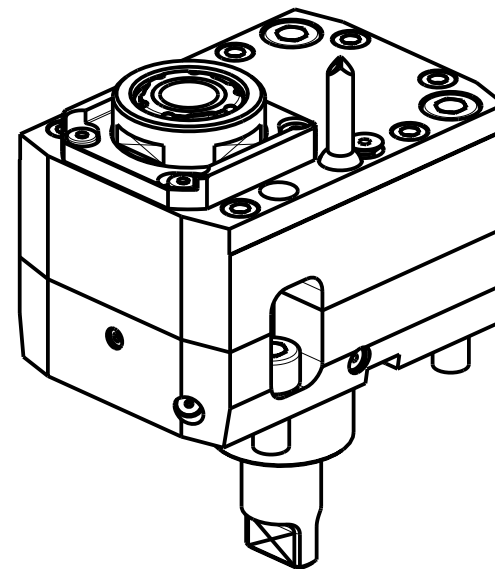
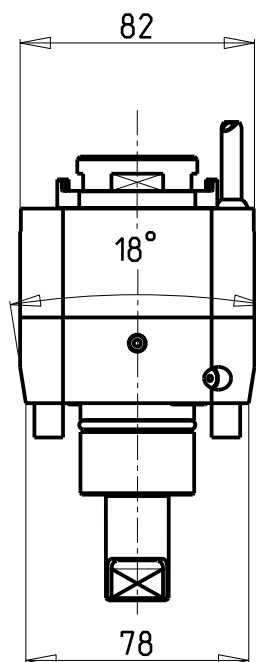
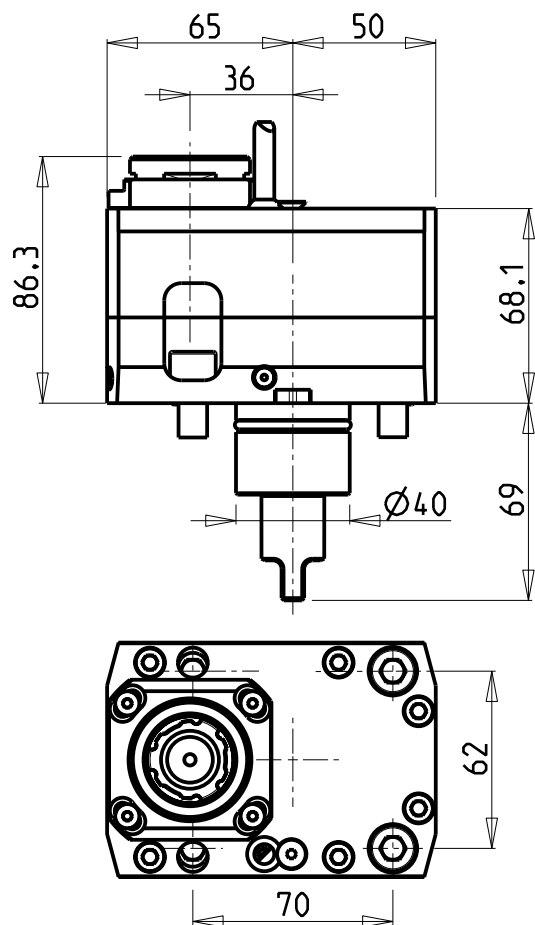

- Chiave inclusa
- Key included
- Schluessel inbegriffen

Cod. MT	Mandrino Spindle Spindel	I	RPM	Coppia Max Max Torque Max Drehmoment	Reversibile lato mandrino/contromandrino Reversible sub/main spindle side Umkehrbare Spindel-seite/ Gegenspindel-seite	Lubr.interna Coolant through Innenkuehlung	Lubr.esterna Ext. coolant Aussenkuehlung	CHIAVI NON INCLUSE Keys not included Schluessel nicht einbegriffen		
								C HUB27	C HTAER25ZC	OKU0290009
MNZ0570325	ERA25	1:1	12000	40Nm	X	-	X	C HUB27	C HTAER25ZC	OKU0290009
MNZ0570425	ERA25	1:1	12000	40Nm	X	P=30bar	X	C HUB27	C HTAER25ZC	OKU0290009

DMG-MORI

NZ1500/2000 - NZX1500/2000 - NL1500/2000/2500 20 STAZ. - NLX1500/2000/2500 20 STAZ.
 NTX1000/2000 - NTX1000/2000/2500/3000 2ND GEN. - NRX2000 - ALX1500/2000/2500

MODULO MOTORIZZATO RADIALE DISASSATO IN Z 36mm 12000 RPM

Radial driven tool re-directed in Z by 36mm 12000 rpm

Radial angetriebenes Werkzeug achsversetzt in Z um 36mm 12000 rpm

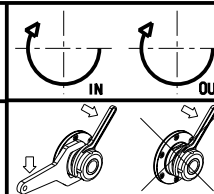

M.T. srl

Via Casino Albini 480
 Tel. 0541/956034-957884
 Fax 0541/956341
 47842 S. GIOVANNI IN M. (RN)
 e-mail: mtma@mtmarchetti.com
 http://www.mtmarchetti.com

PRODUZIONE MODULI ROTANTI



PAGINA MNZ033-1-11

Subject to change without notice.

ATTENZIONE - ATTENTION - ACHTUNG

- Per lo smontaggio degli utensili utilizzare sempre la chiave di contrasto come indicato nel manuale d'uso.
- For disassembly of the tools use always the contrast key as mentioned in the user instructions.
- Fuer das Abmontieren der Werkzeuge immer den Gegenschlüssel benutzen wie in der Bedienungsanleitung erwaeht.

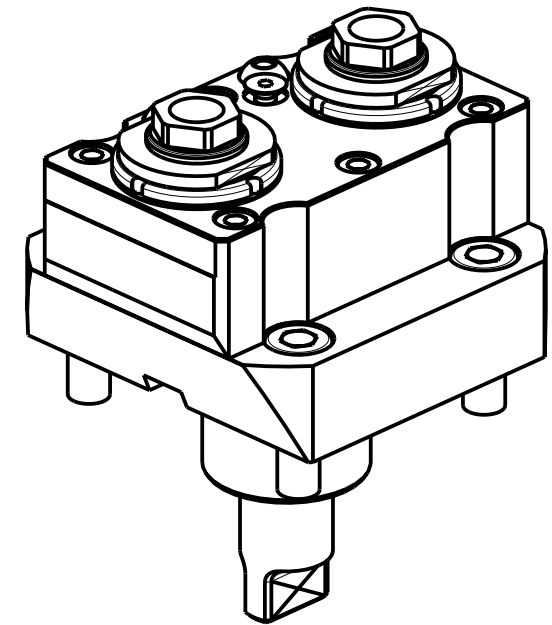
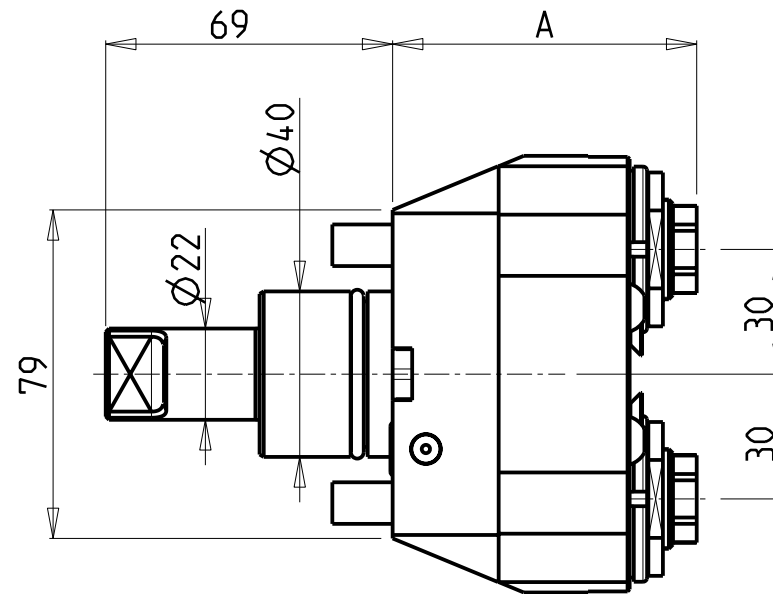
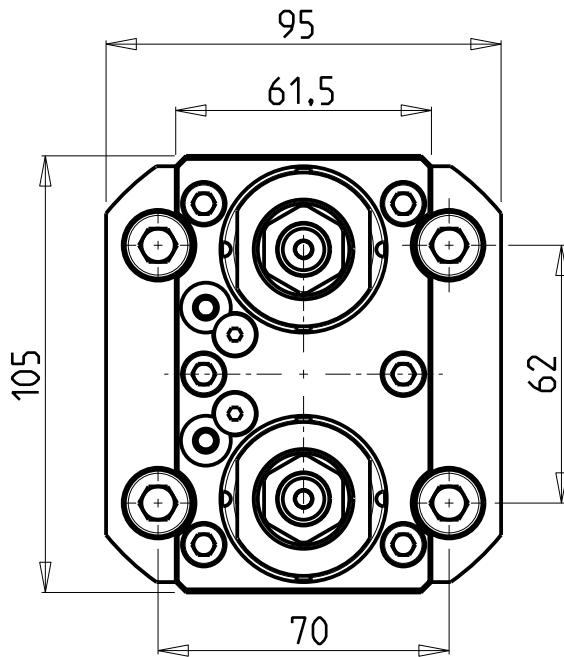

Cod. MT	Mandrino Spindle Spindel	I	RPM	Coppia Max Max Torque Max Drehmoment	Lubrificazione int. Coolant through Innenkuehlung	Lubrificazione est. Ext. coolant Aussenkuehlung	A	CHIAVI NON INCLUSE Keys not included Schluesssel nicht einbegriffen	
MNZ0030416	ER A 16	1:1	6000	30Nm		X	73.13	CHUB32	CHUB19_SP3
MNZ0030516	ER A 16	1:1	6000	30Nm	P=70bar	X	83.13	CHUB32	CHUB19_SP3
MNZ0030420	ER20	1:1	6000	30Nm		X	89.66	CHUB32	CHSTER20

DMG-MORI

NZ1500/2000 - NZX1500/2000 - NT3000 SERIE - NL1500/2000/2500 20 STAZ. - NLX1500/2000/2500 20 STAZ.
NT1000/2000 - NTX1000/2000/2500/3000 2ND GEN. 12ST. - DURATURN 2050MC/2550MC - ALX1500/2000/2500

MODULO MOTORIZZATO RADIALE 2 USCITE IN Y

Radial single side twin head driven tool in Y

Radial angetriebenes Werkzeug 2 Ausgaenge ueberlagert in Y

Subject to change without notice.

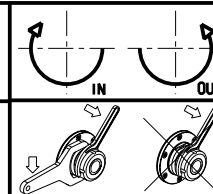

M.T. srl

Via Casino Albini 480
Tel. 0541/956034-957884
Fax 0541/956341
47842 S. GIOVANNI IN M. (RN)
e-mail: mtma@mtmarchetti.com
http://www.mtmarchetti.com

PRODUZIONE MODULI ROTANTI



PAGINA MNZ080-1-00

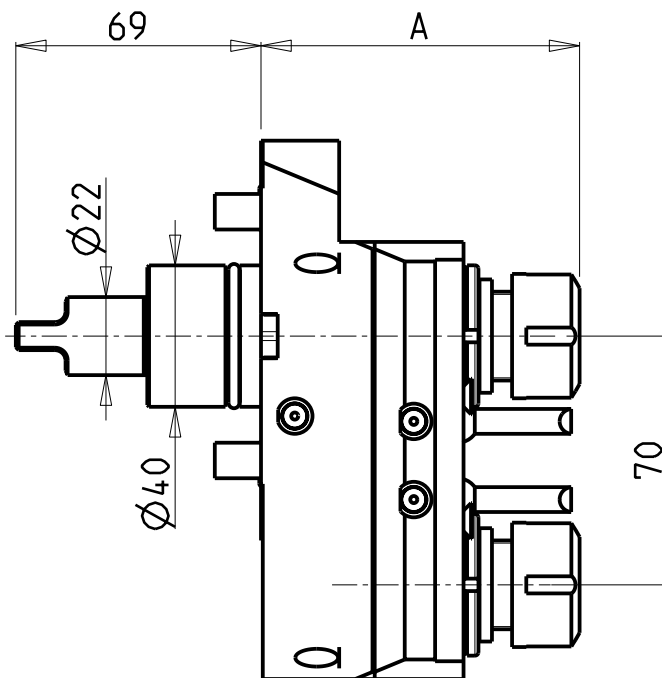
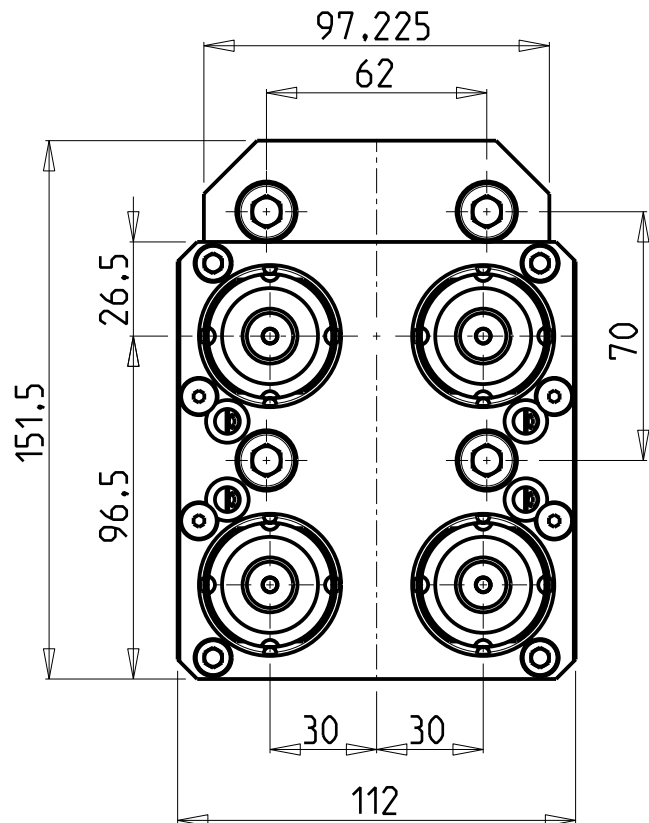

ATTENZIONE - ATTENTION - ACHTUNG

- Per lo smontaggio degli utensili utilizzare sempre la chiave di contrasto come indicato nel manuale d'uso.
- For disassembly of the tools use always the contrast key as mentioned in the user instructions.
- Fuer das Abmontieren der Werkzeuge immer den Gegenschlüssel benutzen wie in der Bedienungsanleitung erwaeht.

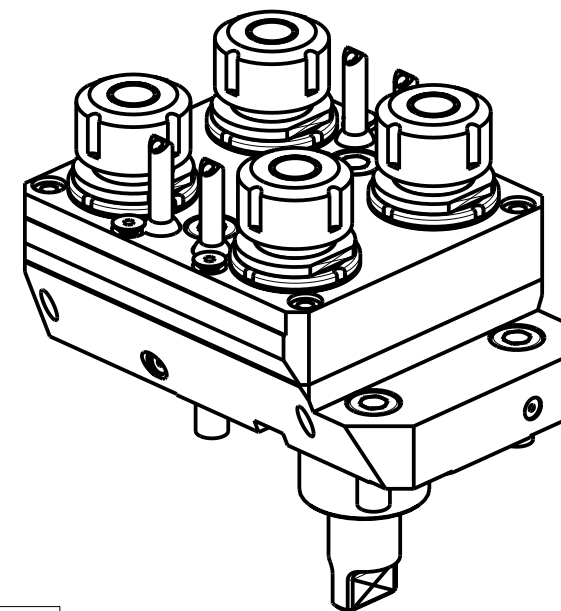

Cod. MT	Mandrino Spindle Spindel	I	RPM	Coppia Max Max Torque Max Drehmoment	N°Utensili N°Tools N°Werkzeuge	Reversibile lato mandrino/contromandrino Reversible sub/main spindle side Umkehrbare Spindel-seite/ Gegenspindel-seite	Lubrificazione est. Ext. coolant Auslenkuehlung	A	CHIAVI INCLUSE Keys included Schlüssel einbegriffen	
									CHUB32	CHSTER16
MNZ0030116	ER16	1:1	6000	30Nm	4	X	X	67.26	CHUB32	CHSTER16
MNZ0030120	ER20	1:1	6000	30Nm	4	X	X	89.66	CHUB32	CHSTER20

DMG-MORI

NZ1500/2000 - NZX1500/2000 - NT3000 SERIE - NL1500/2000/2500 20 STAZ. - NLX1500/2000/2500 20 STAZ.
NT1000/2000 - NTX1000/2000/2500/3000 2ND GEN. 12ST. - DURATURN 2050MC/2550MC - ALX1500/2000/2500

MODULO MOTORIZZATO RADIALE 4 USCITE

Radial 4 head driven tool

Radial angetriebenes Werkzeug 4 Ausgaenge

Subject to change without notice.

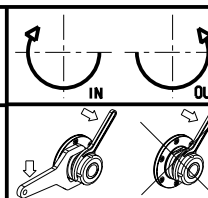

M.T. srl

Via Casino Albini 480
Tel. 0541/956034-957884
Fax 0541/956341
47842 S. GIOVANNI IN M. (RN)
e-mail: mtma@mtmarchetti.com
http://www.mtmarchetti.com

PRODUZIONE MODULI ROTANTI



PAGINA MNZ100-1-00

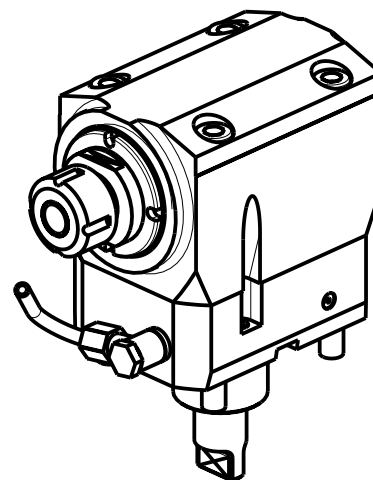
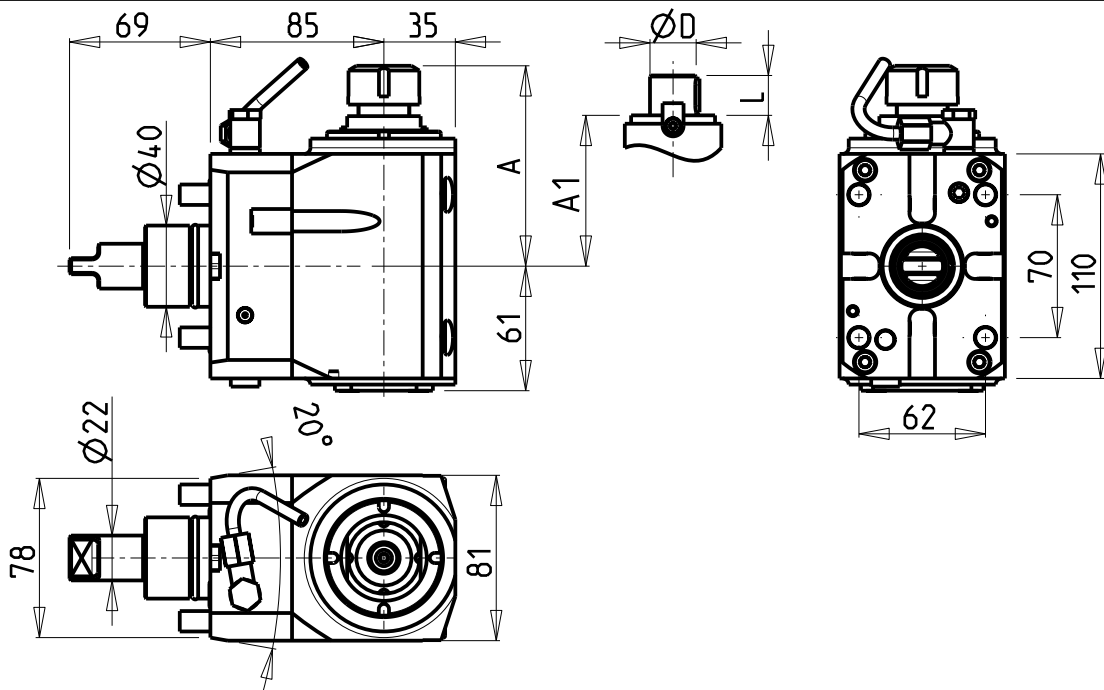

ATTENZIONE - ATTENTION - ACHTUNG

- Per lo smontaggio degli utensili utilizzare sempre la chiave di contrasto come indicato nel manuale d'uso.
- For disassembly of the tools use always the contrast key as mentioned in the user instructions.
- Fuer das Abmontieren der Werkzeuge immer den Gegenschlüssel benutzen wie in der Bedienungsanleitung erwäehnt.

- Chiave inclusa
- Key included
- Schlüssel inbegriffen

Cod. MT	Cod. MORI-SEIKI	Mandrino Spindle Spindel	I	RPM	Coppia Max Max Torque Max Drehmoment	Reversibile lato mandrino/contromandrino Reversible sub/main spindle side Umkehrbare Spindel-seite/ Gegenspindel-seite	Lubr.interna Coolant through Innenkuehlung	Lubr.esterna Ext. coolant Aussenkuehlung	A	A1	B	D	L	CHIAVI NON INCLUDE Keys not included Schluessel nicht einbegriffen	
MNZ0010120	T32255	ER20	1:1	6000	40Nm	X		X	98.16	-	61	-	-	CHUB36	CHSTER20
MNZ0010125	T32275	ER25	1:1	6000	40Nm	X		X	99.16	-	61	-	-	CHUB36	CHSTER25
MNZ0010132		ER32	1:1	6000	40Nm	X		X	102.16	-	61	-	-	CHUB36	CHSTER32
MNZ0010225		ER25	1:1	6000	40Nm	X	P=70bar	X	99.16	-	71	-	-	CHUB36	CHSTER25
MNZ0010232		ER32	1:1	6000	40Nm	X	P=70bar	X	102.76	-	71	-	-	CHUB36	CHSTER32
MNZ0011617		Ø16x17	1:1	6000	40Nm	X		X	-	76.5	61	16	17	CHUB36	CH_VTCROCE_M08 •
MNZ0012219		Ø22x19	1:1	6000	40Nm	X		X	-	78.5	61	22	19	CHUB36	CH_VTCROCE_M10 •
MNZ0012721		Ø27x21	1:1	6000	40Nm	X		X	-	79.5	61	27	21	CHUB36	CH_VTCROCE_M12 •
MNZ0011919		Ø3/4"x3/4"	1:1	6000	40Nm	X		X	-	77	61	3/4"	3/4"	CHUB36	CH_VTCROCE_M08 •

DMG-MORI

NZ1500/2000 - NZX1500/2000 - NT3000 SERIE - NL1500/2000/2500 20 STAZ. - NLX1500/2000/2500 20 STAZ.
 NT1000/2000 - NTX1000/2000 - NTX1000/2000/2500/3000 2ND GEN. 12ST. - DURATURN 2050MC/2550MC - NRX2000 - ALX1500/2000/2500

MODULO MOTORIZZATO ASSIALE H=85mm

Axial driven tool H=85mm

Axial angetriebenes Werkzeug H=85mm

Subject to change without notice.

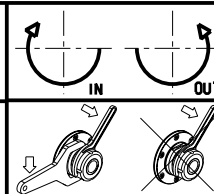

M.T. srl

Via Casino Albini 480
 Tel. 0541/956034-957884
 Fax 0541/956341
 47842 S. GIOVANNI IN M. (RN)
 e-mail: mtma@tmarchetti.com
 http://www.tmmarchetti.com

PRODUZIONE MODULI ROTANTI



PAGINA MNZ150-1-10

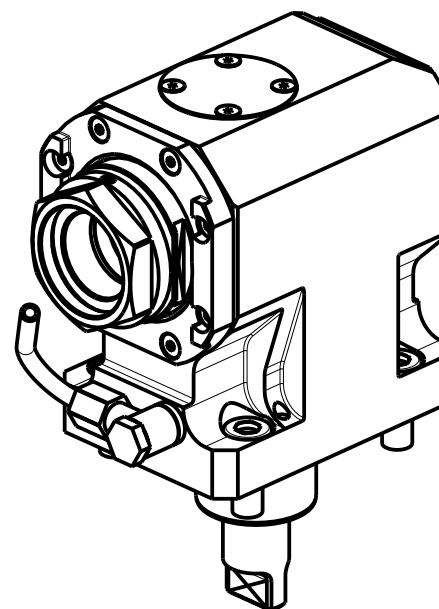
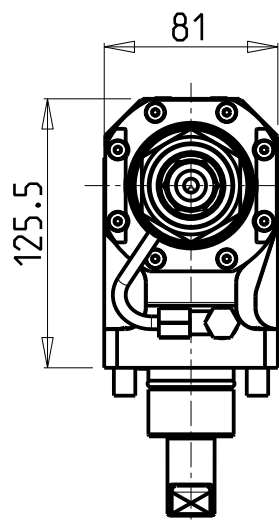
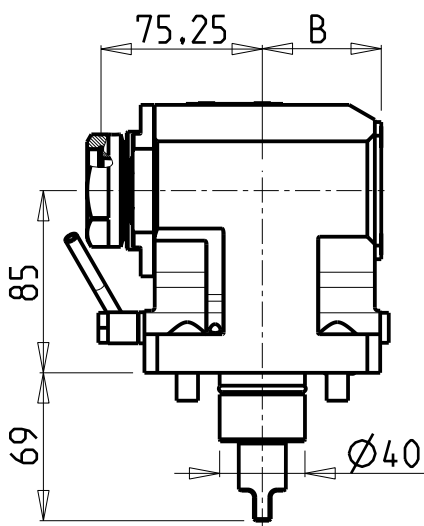
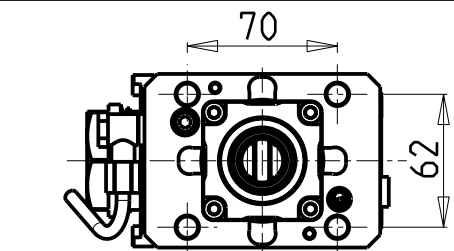

ATTENZIONE - ATTENTION - ACHTUNG

- Per lo smontaggio degli utensili utilizzare sempre la chiave di contrasto come indicato nel manuale d'uso.
- For disassembly of the tools use always the contrast key as mentioned in the user instructions.
- Fuer das Abmontieren der Werkzeuge immer den Gegenschlüssel benutzen wie in der Bedienungsanleitung erwaeht.

PER PORTAUTENSILI MODULARI MTSK-40 VEDI PAG. TBL300-1-40
 FOR MTSK-40 QUIK CHANGE TOOLHOLDERS CLAMPINGS SEE PAGE TBL300-1-40
 FUER MTSK-40 MODULARE WERKZEUGAUFNAHMEN SIEHE SEITE TBL300-1-40

Cod. MT	Mandrino Spindle Spindel	I	RPM	Coppia Max Max Torque Max Drehmoment	Reversibile lato mandrino/contromandrino Reversible sub/main spindle side Umkehrbare Spindel-seite/ Gegenspindel-seite	Lubr.interna Coolant through Innenkuehlung	Lubr.esterna Ext. coolant Aussenkuehlung	B	CHIAVI NON INCLUSE Keys not included Schluessel nicht einbegriffen	
MNZ0400140	MTSK-40	1:1	6000	40Nm	X		X	55.5	CHUB46	MNZ0410005 ▪
MNZ0400240	MTSK-40	1:1	6000	40Nm	X	P=70bar	X	69	CHUB46	MNZ0410005 ▪

- Chiave inclusa
- Key included
- Schluessel inbegriffen

DMG-MORI
 NZ1500/2000 - NZX1500/2000 - NT3000 SERIE - NL1500/2000/2500 20 STAZ. - NLX1500/2000/2500 20 STAZ.
 NT1000/2000 - NTX1000/2000 - NTX1000/2000/2500/3000 2ND GEN. 12ST. - DURATURN 2050MC/2550MC - NRX2000 - ALX1500/2000/2500

MODULO MOTORIZZATO ASSIALE MTSK
 Axial MTSK driven tool
 Axial MTSK angetriebenes Werkzeug

Subject to change without notice.

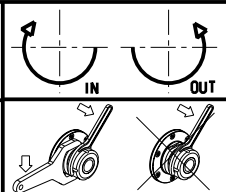

M.T. srl
 Via Casino Albini 480
 Tel. 0541/956034-957884
 Fax 0541/956341
 47842 S. GIOVANNI IN M. (RN)
 e-mail: mtma@mtmarchetti.com
 http://www.mtmarchetti.com

PRODUZIONE MODULI ROTANTI



PAGINA MNZ150-1-10-K

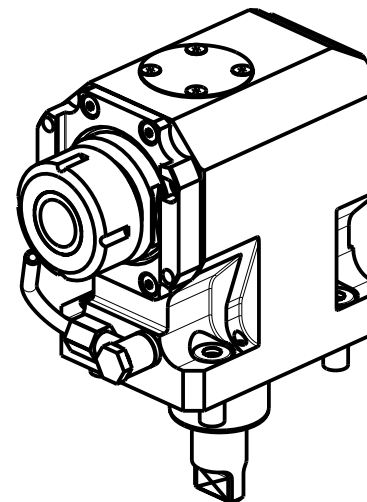
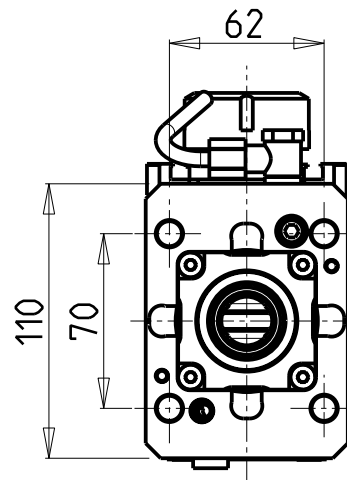
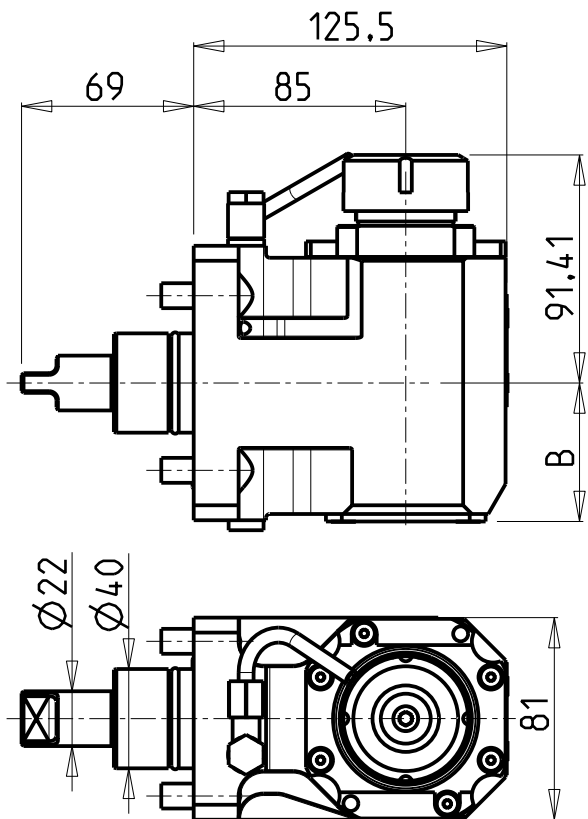

ATTENZIONE - ATTENTION - ACHTUNG

- Per lo smontaggio degli utensili utilizzare sempre la chiave di contrasto come indicato nel manuale d'uso.
- For disassembly of the tools use always the contrast key as mentioned in the user instructions.
- Fuer das Abmontieren der Werkzeuge immer den Gegenschlüssel benutzen wie in der Bedienungsanleitung erwaeht.

- Chiave inclusa
- Key included
- Schluesel inbegriffen

Cod. MT	Mandrino Spindle Spindel	I	RPM	Coppia Max Max Torque Max Drehmoment	Reversibile lato mandrino/contromandrino Reversible sub/main spindle side Umkehrbare Spindel-seite/ Gegenspindel-seite	Lubr.interna Coolant through Innenkuehlung	Lubr.esterna Ext. coolant Aussenkuehlung	B	CHIAVI NON INCLUSE Keys not included Schluesel nicht einbegriffen	
MNZ0470125	ER25	1:1	12000	40Nm	X	-	X	55.5	CHSTER25	MNZ0410005 •
MNZ0470225	ER25	1:1	12000	40Nm	X	P=70bar	X	69	CHSTER25	MNZ0410005 •
MNZ0470132	ER32	1:1	12000	40Nm	X	-	X	55.5	CHSTER32	MNZ0410005 •
MNZ0470232	ER32	1:1	12000	40Nm	X	P=70bar	X	69	CHSTER32	MNZ0410005 •

DMG-MORI

NZ1500/2000 - NZX1500/2000 - NL1500/2000/2500 20 STAZ. - NLX1500/2000/2500 20 STAZ.
 NTX1000/2000 - NTX1000/2000/2500/3000 2ND GEN. 12ST. - NRX2000

MODULO MOTORIZZATO ASSIALE 12000 RPM H=85mm

Axial driven tool 12000 rpm H=85mm

Axial angetriebenes Werkzeug 12000 rpm H=85mm

Subject to change without notice.

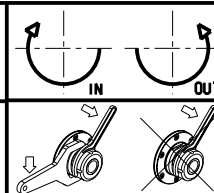

M.T. srl

Via Casino Albini 480
 Tel. 0541/956034-957884
 Fax 0541/956341
 47842 S. GIOVANNI IN M. (RN)
 e-mail: mtma@tmarchetti.com
 http://www.mtmarchetti.com

PRODUZIONE MODULI ROTANTI



PAGINA MNZ150-1-11

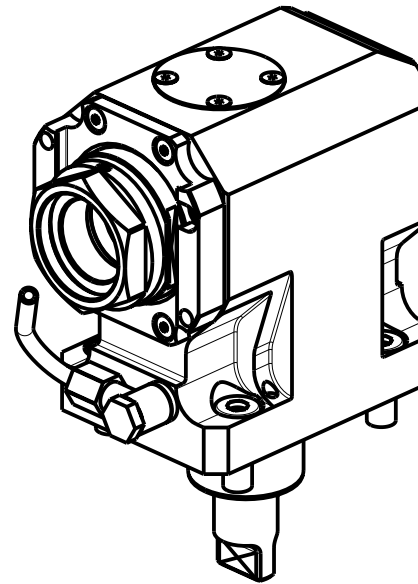
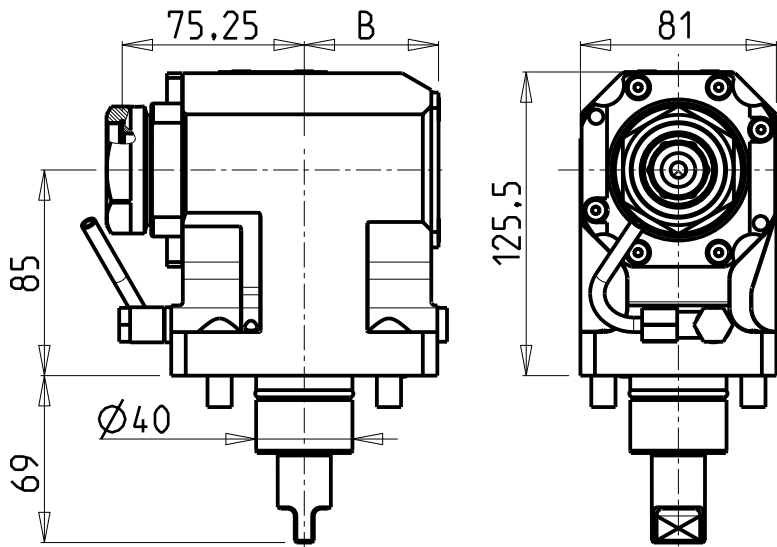
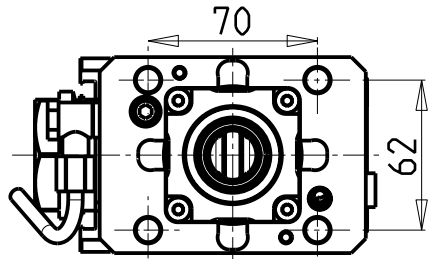

ATTENZIONE - ATTENTION - ACHTUNG

- Per lo smontaggio degli utensili utilizzare sempre la chiave di contrasto come indicato nel manuale d'uso.
- For disassembly of the tools use always the contrast key as mentioned in the user instructions.
- Fuer das Abmontieren der Werkzeuge immer den Gegenschlüssel benutzen wie in der Bedienungsanleitung erwaehtnt.

PER PORTAUTENSILI MODULARI MTSK-40 VEDI PAG. TBL300-1-40
 FOR MTSK-40 QUIK CHANGE TOOLHOLDERS CLAMPINGS SEE PAGE TBL300-1-40
 FUER MTSK-40 MODULARE WERKZEUGAUFNAHMEN SIEHE SEITE TBL300-1-40

Cod. MT	Mandrino Spindle Spindel	I	RPM	Coppia Max Max Torque Max Drehmoment	Reversibile lato mandrino/contromandrino Reversible sub/main spindle side Umkehrbare Spindel-seite/ Gegenspindel-seite	Lubr.interna Coolant through Innenkuehlung	Lubr.esterna Ext. coolant Aussenkuehlung	B	CHIAVI NON INCLUSE Keys not included Schluessel nicht einbegriffen	
MNZ0480140	MTSK-40	1:1	12000	40Nm	X	-	X	55.5	CHUB46	MNZ0410005 ▪
MNZ0480240	MTSK-40	1:1	12000	40Nm	X	P=70bar	X	69	CHUB46	MNZ0410005 ▪

- Chiave inclusa
- Key included
- Schluessel inbegriffen

DMG-MORI
 NZ1500/2000 - NZX1500/2000 - NL1500/2000/2500 20 STAZ. - NLX1500/2000/2500 20 STAZ.
 NTX1000/2000 - NTX1000/2000/2500/3000 2ND GEN. 12ST. - NRX2000

MODULO MOTORIZZATO ASSIALE MTSK 12000 RPM H=85mm
 Axial MTSK driven tool 12000 rpm H=85mm
 Axial MTSK angetriebenes Werkzeug 12000 rpm H=85mm

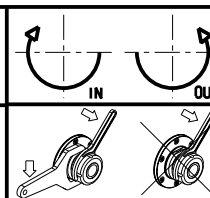

M.T. srl
 Via Casino Albini 480
 Tel. 0541/956034-957884
 Fax 0541/956341
 47842 S. GIOVANNI IN M. (RN)
 e-mail: mtma@mtmarchetti.com
 http://www.mtmarchetti.com

PRODUZIONE MODULI ROTANTI

PAGINA MNZ150-1-11-K

Subject to change without notice.

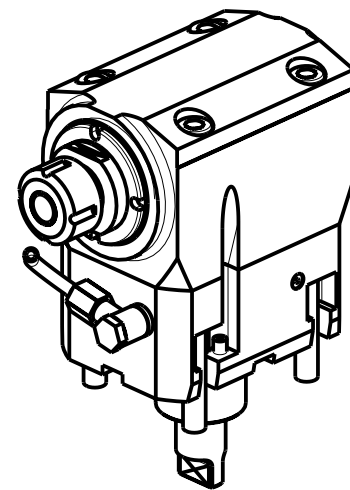
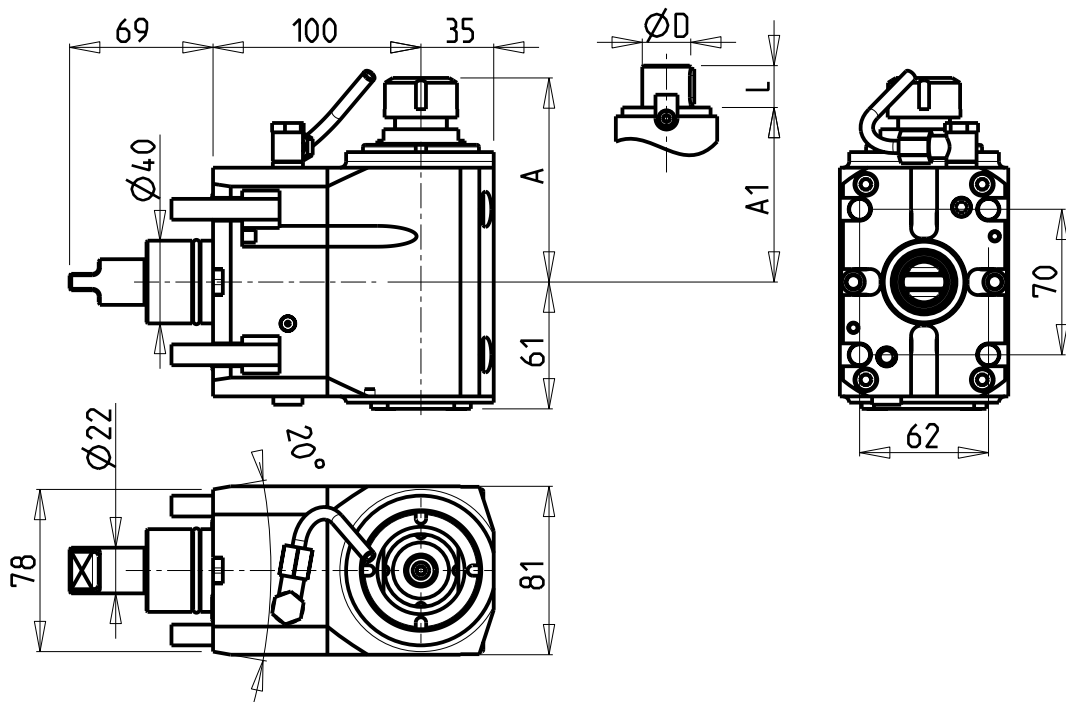

- Chiave inclusa
- Key included
- Schlüssel inbegriffen

ATTENZIONE - ATTENTION - ACHTUNG

- Per lo smontaggio degli utensili utilizzare sempre la chiave di contrasto come indicato nel manuale d'uso.
- For disassembly of the tools use always the contrast key as mentioned in the user instructions.
- Für das Abmontieren der Werkzeuge immer den Gegenschlüssel benutzen wie in der Bedienungsanleitung erwähnt.

ATTENZIONE - ATTENTION - ACHTUNG

- VERIFICARE LE MISURE DI INGOMBRO PER POSSIBILE INTERFERENZA SU ALCUNI MODELLI DI MACCHINE
- Please check the overall sizes for possible interferences on some machine models
- Bitte überprüfen sie das ausmass um mögliche interferenzen auf einigen maschinen modellen zu vermeiden

Cod. MT	Mandrino Spindle Spindel	I	RPM	Coppia Max Max Torque Max Drehmoment	Reversibile lato mandrino/contromandrino Reversible sub/main spindle side Umkehrbare Spindel-seite/ Gegen-spindel-seite	Lubr.interna Coolant through Innenkuehlung	Lubr.esterna Ext. coolant Ausseinkuehlung	A	A1	B	D	L	CHIAVI NON INCLUDE Keys not included Schlüssel nicht einbegriffen	
MNZ0210120	ER20	1:1	6000	40Nm	X		X	98.16	-	61	-	-	CHUB36	CHSTER20
MNZ0210125	ER25	1:1	6000	40Nm	X		X	99.16	-	61	-	-	CHUB36	CHSTER25
MNZ0210132	ER32	1:1	6000	40Nm	X		X	102.16	-	61	-	-	CHUB36	CHSTER32
MNZ0210225	ER25	1:1	6000	40Nm	X	P=70bar	X	99.16	-	71	-	-	CHUB36	CHSTER25
MNZ0210232	ER32	1:1	6000	40Nm	X	P=70bar	X	102.76	-	71	-	-	CHUB36	CHSTER32
MNZ0211617	Ø16x17	1:1	6000	40Nm	X		X	-	76.5	61	16	17	CHUB36	CH_VTCROCE_M08 ■
MNZ0212219	Ø22x19	1:1	6000	40Nm	X		X	-	78.5	61	22	19	CHUB36	CH_VTCROCE_M10 ■
MNZ0212721	Ø27x21	1:1	6000	40Nm	X		X	-	79.5	61	27	21	CHUB36	CH_VTCROCE_M12 ■
MNZ0211919	Ø3/4"x3/4"	1:1	6000	40Nm	X		X	-	77	61	3/4"	3/4"	CHUB36	CH_VTCROCE_M08 ■

DMG-MORI

NZ1500/2000 - NZX1500/2000 - NT3000 SERIE - NL1500/2000/2500 20 STAZ. - NLX1500/2000/2500 20 STAZ.
 NT1000/2000 - NTX1000/2000 - NTX1000/2000/2500/3000 2ND GEN. 12ST. - DURATURN 2050MC/2550MC - ALX1500/2000/2500

MODULO MOTORIZZATO ASSIALE H=100mm

Axial driven tool H=100mm

Axial angetriebenes Werkzeug H=100mm

Subject to change without notice.

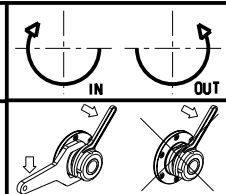

M.T. srl

Via Casino Albini 480
 Tel. 0541/956034-957884
 Fax 0541/956341

47842 S. GIOVANNI IN M. (RN)
 e-mail: mtma@mtmarchetti.com
 http://www.mtmarchetti.com

PRODUZIONE MODULI ROTANTI



PAGINA MNZ150-1-20

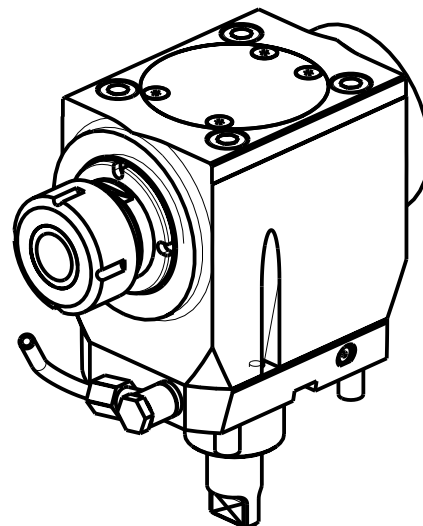
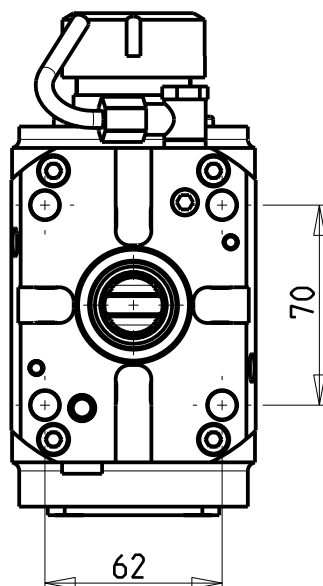
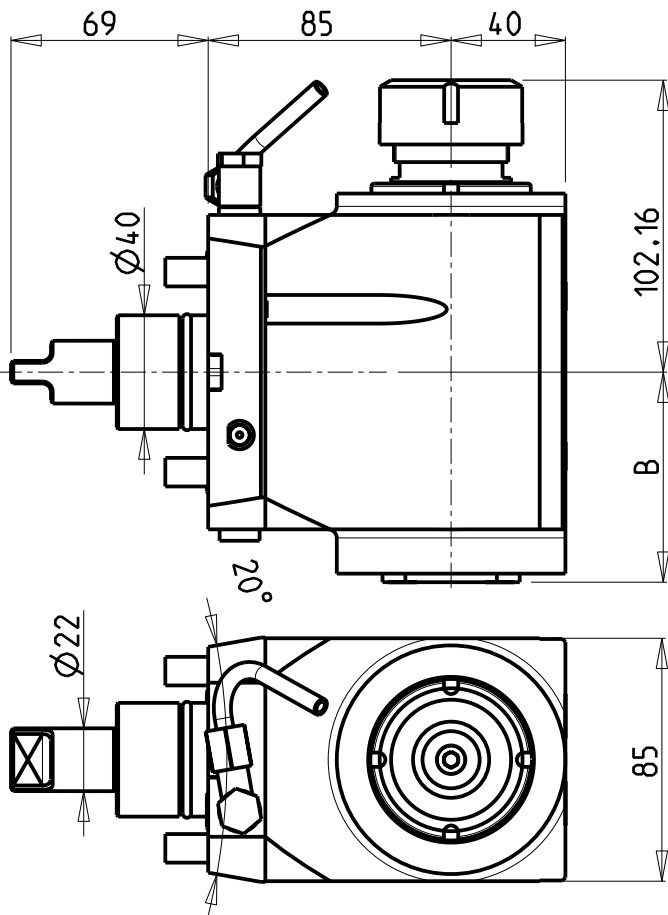

ATTENZIONE - ATTENTION - ACHTUNG

- Per lo smontaggio degli utensili utilizzare sempre la chiave di contrasto come indicato nel manuale d'uso.
- For disassembly of the tools use always the contrast key as mentioned in the user instructions.
- Fuer das Abmontieren der Werkzeuge immer den Gegenschlüssel benutzen wie in der Bedienungsanleitung erwäehnt.

ATTENZIONE - ATTENTION - ACHTUNG

- VERIFICARE LE MISURE DI INGOMBRO PER POSSIBILE INTERFERENZA SU ALCUNI MODELLI DI MACCHINE
- Please check the overall sizes for possible interferences on some machine models
- Bitte überprüfen sie das ausmass um mögliche interferenzen auf einigen maschinen modellen zu vermeiden

Cod. MT	Mandrino Spindle Spindel	I	RPM	Coppia Max Max Torque Max Drehmoment	Reversibile lato mandrino/contromandrino Reversible sub/main spindle side Umkehrbare Spindel-seite/ Gegenspindel-seite	Lubrificazione int. Coolant through Innenkuehlung	Lubrificazione est. Ext. coolant Aussenkuehlung	B	CHIAVI NON INCLUSE Keys not included Schluessel nicht einbegriffen	
MNZ0070132	ER32	2:1	3000	70Nm	X		X	73.5	CHUB36	CHSTER32
MNZ0070232	ER32	2:1	3000	70Nm	X	P=70bar	X	83.5	CHUB36	CHSTER32

DMG-MORI

NZ1500/2000 - NZX1500/2000 - NT3000 SERIE - NL1500/2000/2500 20 STAZ. - NLX1500/2000/2500 20 STAZ.
 NT1000/2000 - NTX1000/2000 - NTX1000/2000/2500/3000 2ND GEN. 12ST. - DURATURN 2050MC/2550MC - NRX2000 - ALX1500/2000/2500

MODULO MOTORIZZATO ASSIALE RIDOTTO I=2:1

Axial geared-down I=2:1 driven tool

Axial angetriebenes Werkzeug untersetzt I=2:1

Subject to change without notice.

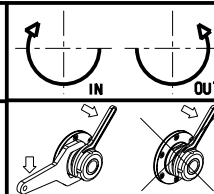

M.T. srl

Via Casino Albini 480
 Tel. 0541/956034-957884
 Fax 0541/956341

47842 S. GIOVANNI IN M. (RN)
 e-mail: mtma@mtmarchetti.com
 http://www.mtmarchetti.com

PRODUZIONE MODULI ROTANTI



PAGINA MNZ190-1-10

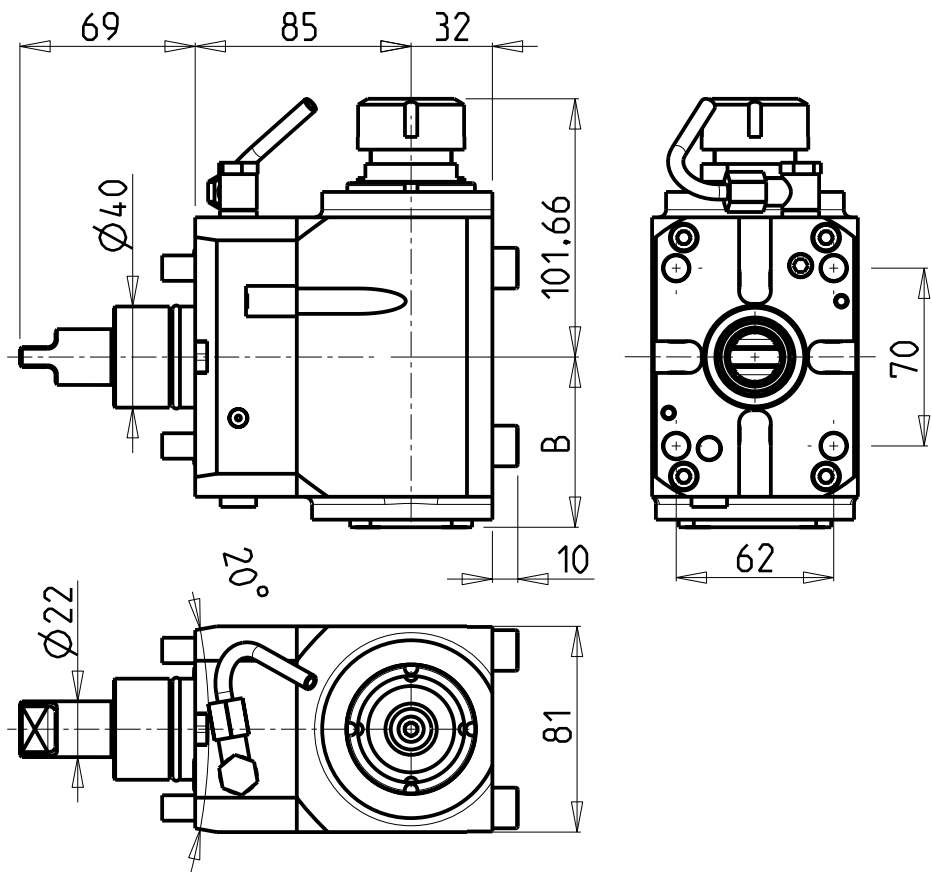

ATTENZIONE - ATTENTION - ACHTUNG

- VERIFICARE LE MISURE DI INGOMBRO PER POSSIBILE INTERFERENZA SU ALCUNI MODELLI DI MACCHINE
- Please check the overall sizes for possible interferences on some machine models
- Bitte überprüfen sie das ausmass um mögliche interferenzen auf einigen maschinen modellen zu vermeiden

ATTENZIONE - ATTENTION - ACHTUNG

- Per lo smontaggio degli utensili utilizzare sempre la chiave di contrasto come indicato nel manuale d'uso.
- For disassembly of the tools use always the contrast key as mentioned in the user instructions.
- Fuer das Abmontieren der Werkzeuge immer den Gegenschlüssel benutzen wie in der Bedienungsanleitung erwaeht.

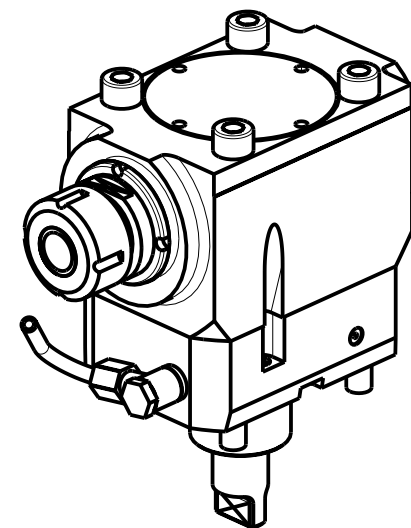

Cod. MT	Mandrino Spindle Spindel	I	RPM	Coppia Max Max Torque Max Drehmoment	Reversibile lato mandrino/contromandrino Reversible sub/main spindle side Umkehrbare Spindel-seite/ Gegenspindel-seite	Lubrificazione int. Coolant through Innenkuehlung	Lubrificazione est. Ext. coolant Aussenkuehlung	B	CHIAVI NON INCLUSE Keys not included Schluessel nicht einbegriffen	
MNZ0080125	ER25	1:2	12000	30Nm	X		X	67	CHUB36	CHSTER25
MNZ0080225	ER25	1:2	12000	30Nm	X	P=70bar	X	77	CHUB36	CHSTER25

DMG-MORI

NZ1500/2000 - NZX1500/2000 - NT3000 SERIE - NL1500/2000/2500 20 STAZ. - NLX1500/2000/2500 20 STAZ.
 NT1000/2000 - NTX1000/2000 - NTX1000/2000/2500/3000 2ND GEN. 12ST. - DURATURN 2050MC/2550MC - NRX2000 - ALX1500/2000/2500

MODULO MOTORIZZATO ASSIALE MOLTIPLICATO I=1:2 H=85mm

Axial geared-up I=1:2 driven tool H=85mm

Axial angetriebenes Werkzeug uebersetzt I=1:2 H=85mm

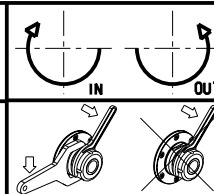

M.T. srl

Via Casino Albini 480
 Tel. 0541/956034-957884
 Fax 0541/956341
 47842 S. GIOVANNI IN M. (RN)
 e-mail: mtma@mtmarchetti.com
 http://www.mtmarchetti.com

PRODUZIONE MODULI ROTANTI



PAGINA MNZ200-1-10

Subject to change without notice.

10/2018

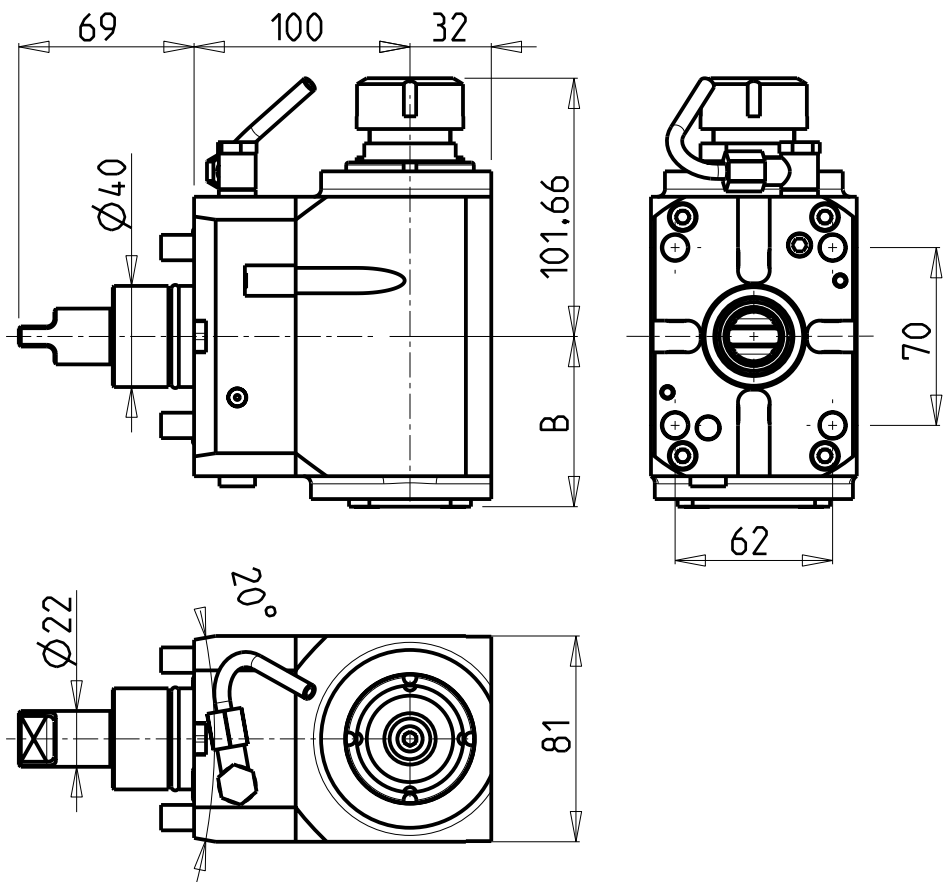

ATTENZIONE - ATTENTION - ACHTUNG

- VERIFICARE LE MISURE DI INGOMBRO PER POSSIBILE INTERFERENZA SU ALCUNI MODELLI DI MACCHINE
- Please check the overall sizes for possible interferences on some machine models
- Bitte überprüfen sie das ausmass um mögliche interferenzen auf einigen maschinen modellen zu vermeiden

ATTENZIONE - ATTENTION - ACHTUNG

- Per lo smontaggio degli utensili utilizzare sempre la chiave di contrasto come indicato nel manuale d'uso.
- For disassembly of the tools use always the contrast key as mentioned in the user instructions.
- Fuer das Abmontieren der Werkzeuge immer den Gegenschlüssel benutzen wie in der Bedienungsanleitung erwäehnt.

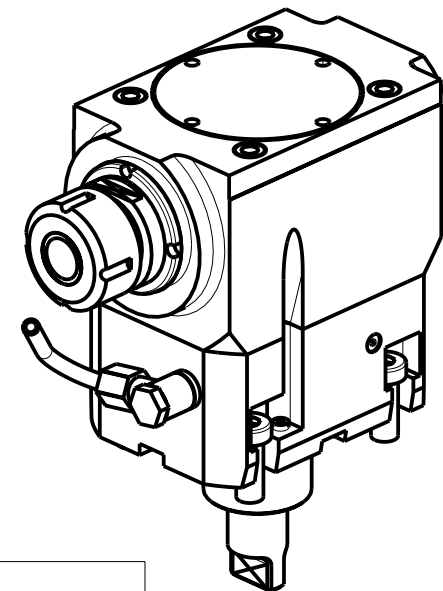

Cod. MT	Mandrino Spindle Spindel	I	RPM	Coppia Max Max Torque Max Drehmoment	Reversibile lato mandrino/contromandrino Reversible sub/main spindle side Umkehrbare Spindel-seite/ Gegenspindel-seite	Lubrificazione int. Coolant through Innenkuehlung	Lubrificazione est. Ext. coolant Aussenkuehlung	B	CHIAVI NON INCLUSE Keys not included Schlüssell nicht einbegriffen	
MNZ0081125	ER25	1:2	12000	30Nm	X		X	67	CHUB36	CHSTER25
MNZ0081225	ER25	1:2	12000	30Nm	X	P=70bar	X	77	CHUB36	CHSTER25

DMG-MORI

NZ1500/2000 - NZX1500/2000 - NT3000 SERIE - NL1500/2000/2500 20 STAZ. - NLX1500/2000/2500 20 STAZ.
 NT1000/2000 - NTX1000/2000 - NTX1000/2000/2500/3000 2ND GEN. 12ST. - DURATURN 2050MC/2550MC - ALX1500/2000/2500

MODULO MOTORIZZATO ASSIALE MOLTIPLICATO I=1:2 H=100mm

Axial geared-up I=1:2 driven tool H=100mm

Axial angetriebenes Werkzeug uebersetzt I=1:2 H=100mm

Subject to change without notice.

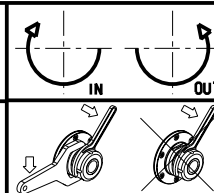

M.T. srl

Via Casino Albini 480
 Tel. 0541/956034-957884
 Fax 0541/956341
 47842 S. GIOVANNI IN M. (RN)
 e-mail: mtma@mtmarchetti.com
 http://www.mtmarchetti.com

PRODUZIONE MODULI ROTANTI



PAGINA MNZ200-1-20

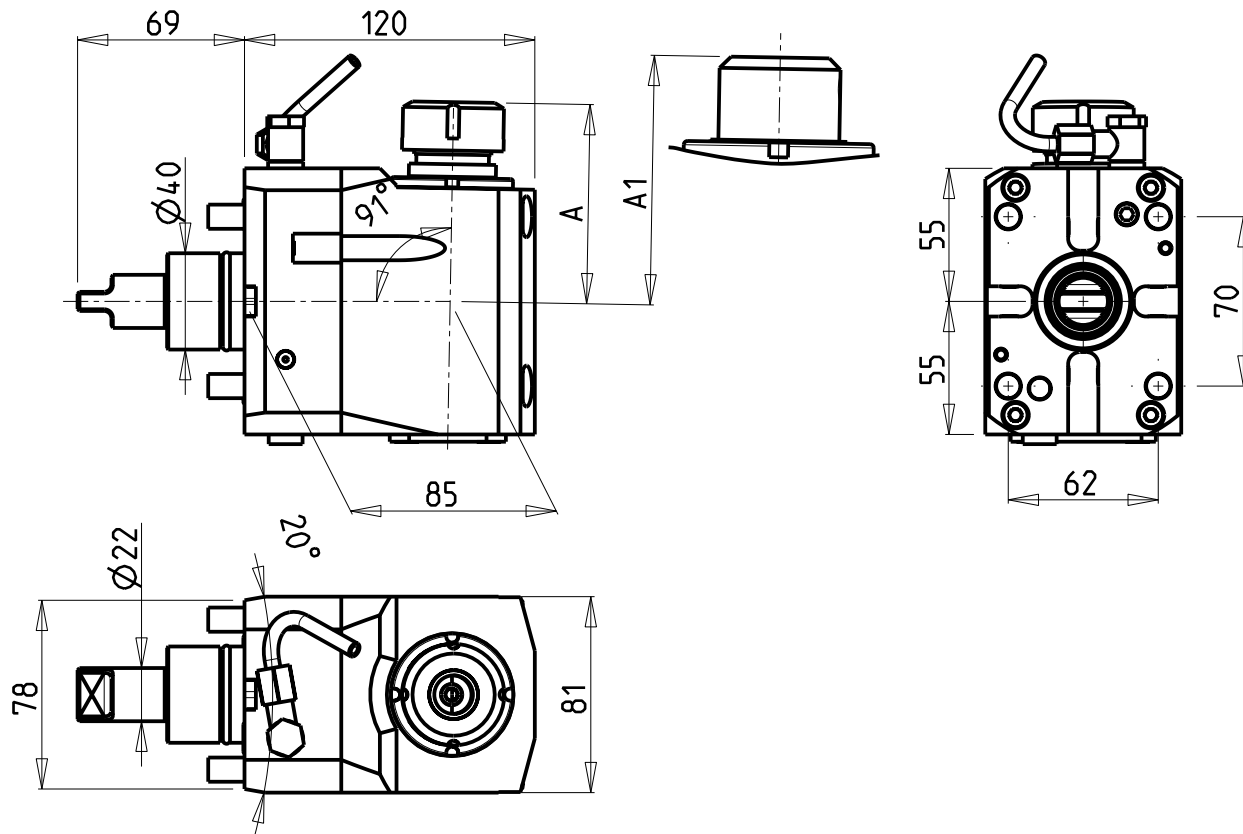

ATTENZIONE - ATTENTION - ACHTUNG

- Per lo smontaggio degli utensili utilizzare sempre la chiave di contrasto come indicato nel manuale d'uso.
- For disassembly of the tools use always the contrast key as mentioned in the user instructions.
- Fuer das Abmontieren der Werkzeuge immer den Gegenschlüssel benutzen wie in der Bedienungsanleitung erwaeht.

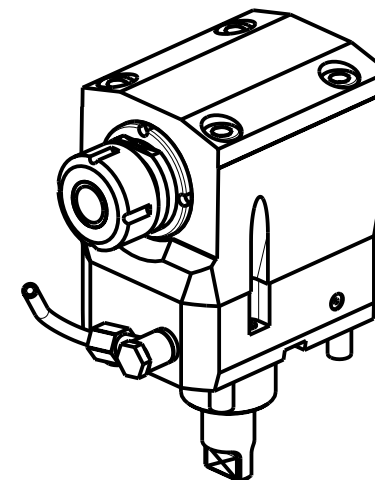

Cod. MT	Mandrino Spindle Spindel	I	RPM	Coppia Max Max Torque Max Drehmoment	Reversibile lato mandrino/contromandrino Reversible sub/main spindle side Umkehrbare Spindelseite/ Gegenspindelseite	Lubr.esterna Ext. coolant Aussenkuehlung	A	A1	CHIAVI NON INCLUSE Keys not included Schluesssel nicht einbegriffen	
									CHUB36	CHSTER25
MNZ0239125	ER25	1:1	6000	40Nm	X	X	82.36		CHUB36	CHSTER25
MNZ0239108	WELDON 8	1:1	6000	40Nm	X	X		76.5		
MNZ0239110	WELDON 10	1:1	6000	40Nm	X	X		76.5		
MNZ0239112	WELDON 12	1:1	6000	40Nm	X	X		76.5		
MNZ0239116	WELDON 16	1:1	6000	40Nm	X	X		73.5		

DMG-MORI

NZ1500/2000 - NZX1500/2000 - NT3000 SERIE - NL1500/2000/2500 20 STAZ. - NLX1500/2000/2500 20 STAZ.
 NT1000/2000 - NTX1000/2000 - NTX1000/2000/2500/3000 2ND GEN. 12ST. - DURATURN 2050MC/2550MC - NRX2000 - ALX1500/2000/2500

MODULO MOTORIZZATO ASSIALE PER POLIGONATURA INTERNA H=85mm

Axial driven tool for internal polygon-making H=85mm

Axial angetriebenes Werkzeug fuer interne Facettierung H=85 mm

Subject to change without notice.

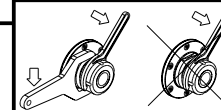

M.T. srl

Via Casino Albini 480
 Tel. 0541/956034-957884
 Fax 0541/956341
 47842 S. GIOVANNI IN M. (RN)
 e-mail: mtma@mtmarchetti.com
 http://www.mtmarchetti.com

PRODUZIONE MODULI ROTANTI



PAGINA MNZ230-1-10

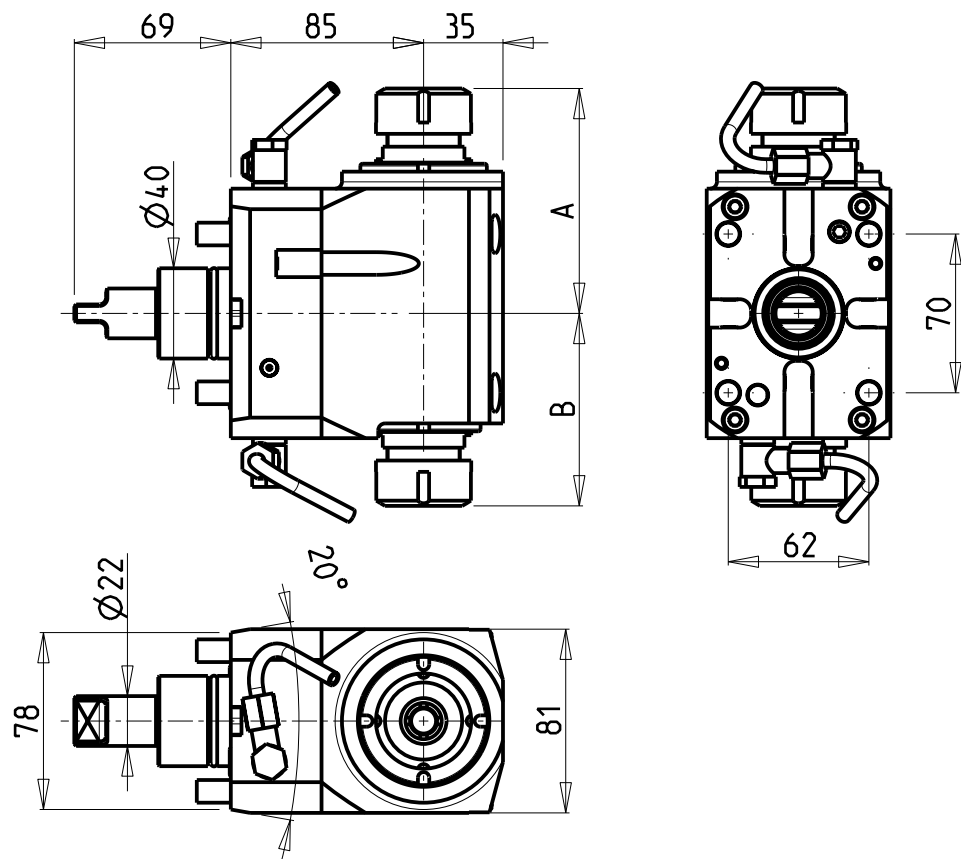

ATTENZIONE - ATTENTION - ACHTUNG

- VERIFICARE LE MISURE DI INGOMBRO PER POSSIBILE INTERFERENZA SU ALCUNI MODELLI DI MACCHINE
- Please check the overall sizes for possible interferences on some machine models
- Bitte überprüfen sie das ausmass um mögliche interferenzen auf einigen maschinen modellen zu vermeiden

ATTENZIONE - ATTENTION - ACHTUNG

- Per lo smontaggio degli utensili utilizzare sempre la chiave di contrasto come indicato nel manuale d'uso.
- For disassembly of the tools use always the contrast key as mentioned in the user instructions.
- Fuer das Abmontieren der Werkzeuge immer den Gegenschlüssel benutzen wie in der Bedienungsanleitung erwaeht.

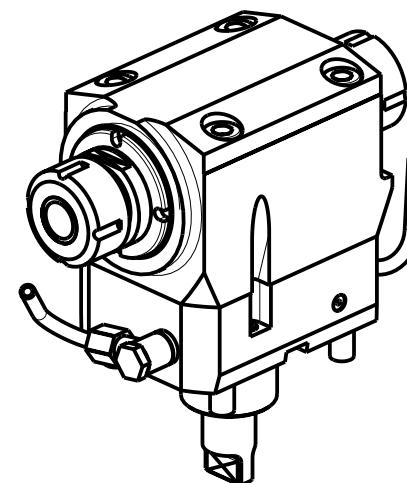

Cod. MT	Cod. MORI-SEIKI	Mandrino Spindle Spindel	I	RPM	Coppia Max Max Torque Max Drehmoment	Reversibile lato mandrino/contromandrino Reversible sub/main spindle side Umkehrbare Spindelseite/ Gegenspindelseite	Lubr.esterna Ext. coolant Aussenkuehlung	A	B	CHIAVI NON INCLUSE Keys not included Schluessel nicht einbegriffen	
MNZ0010325	T32276	ER25+ER25	1:1	6000	40Nm	X	X	85.16	99.16	CHUB36	CHSTER25
MNZ0010332	-	ER32+ER32	1:1	6000	40Nm	X	X	88.16	102.16	CHUB36	CHSTER32

DMG-MORI

NZ1500/2000 - NZX1500/2000 - NT3000 SERIE - NL1500/2000/2500 20 STAZ. - NLX1500/2000/2500 20 STAZ.
NT1000/2000 - NTX1000/2000 - DURATURN 2050MC/2550MC - ALX1500/2000/2500

MODULO MOTORIZZATO ASSIALE BISPORGENTE H=85mm

Axial opposite face twin driven tool H=85mm

Axial angetriebenes Werkzeug halb vorspringend H=85mm

Subject to change without notice.

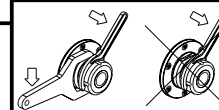

M.T. srl

Via Casino Albini 480
Tel. 0541/956034-957884
Fax 0541/956341
47842 S. GIOVANNI IN M. (RN)
e-mail: mtma@mtmarchetti.com
http://www.mtmarchetti.com

PRODUZIONE MODULI ROTANTI



PAGINA MNZ240-1-10

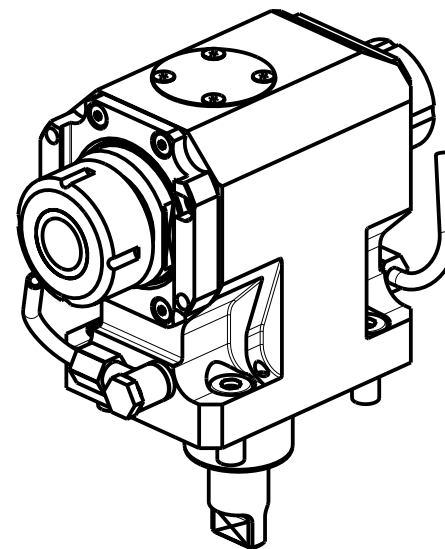
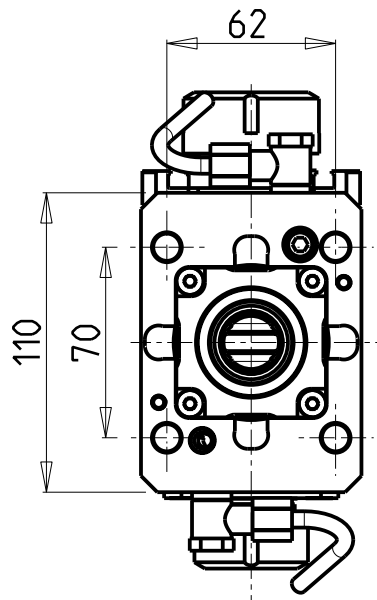
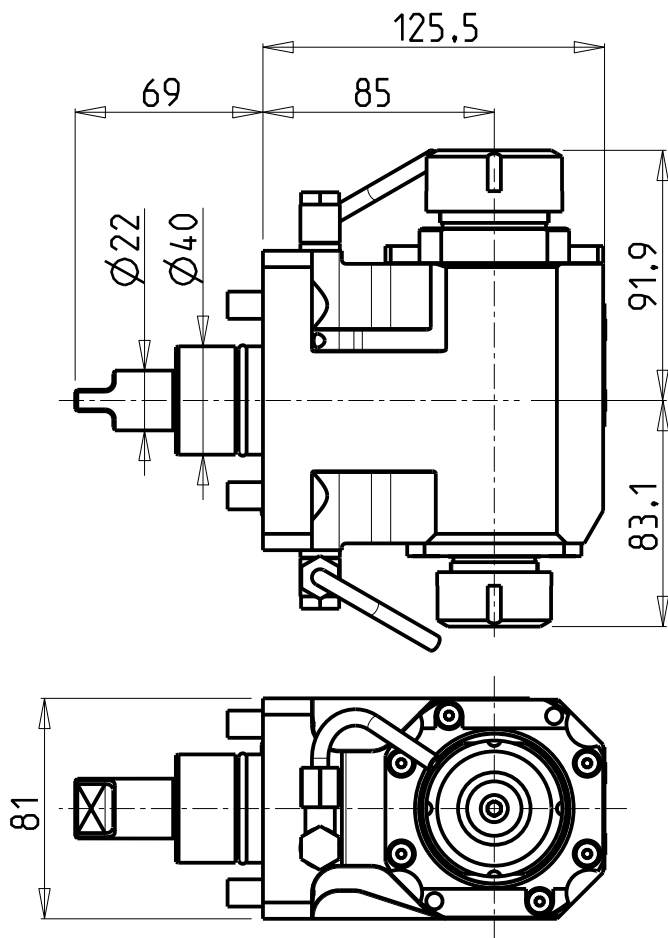

ATTENZIONE - ATTENTION - ACHTUNG

- Per lo smontaggio degli utensili utilizzare sempre la chiave di contrasto come indicato nel manuale d'uso.
- For disassembly of the tools use always the contrast key as mentioned in the user instructions.
- Fuer das Abmontieren der Werkzeuge immer den Gegenschlüssel benutzen wie in der Bedienungsanleitung erwaeht.

- Chiave inclusa
- Key included
- Schlüssel inbegriffen

Cod. MT	Mandrino Spindle Spindel	I	RPM	Coppia Max Max Torque Max Drehmoment	Reversibile lato mandrino/contromandrino Reversible sub/main spindle side Umkehrbare Spindel-seite/ Gegenspindel-seite	Lubr.esterna Ext. coolant Aussenkuehlung	CHIAVI NON INCLUSE Keys not included Schlüssel nicht einbegriffen		
MNZ0493225	ER32+ER25	1:1	12000	40Nm	X	X	CHSTER32	CHSTER25	MNZ0410005 •

DMG-MORI

NZ1500/2000 - NZX1500/2000 - NL1500/2000/2500 20 STAZ. - NLX1500/2000/2500 20 STAZ. - NTX1000/2000

MODULO MOTORIZZATO ASSIALE BISPORGENTE 12000 RPM

Axial opposite face twin driven tool 12000 rpm

Axial angetriebenes Werkzeug halb vorspringend 12000 rpm

Subject to change without notice.

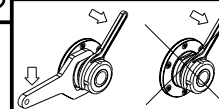

M.T. srl

Via Casino Albini 480
Tel. 0541/956034-957884
Fax 0541/956341
47842 S. GIOVANNI IN M. (RN)
e-mail: mtma@mtmarchetti.com
http://www.mtmarchetti.com

PRODUZIONE MODULI ROTANTI



PAGINA MNZ240-1-11

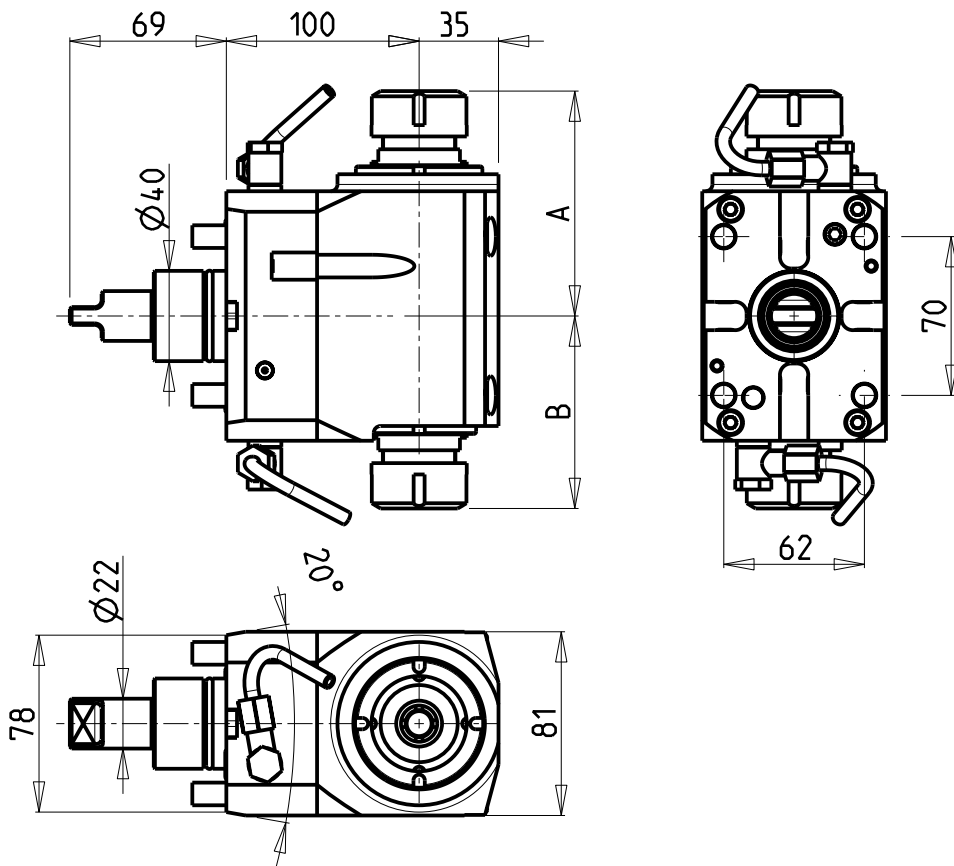

ATTENZIONE - ATTENTION - ACHTUNG

- VERIFICARE LE MISURE DI INGOMBRO PER POSSIBILE INTERFERENZA SU ALCUNI MODELLI DI MACCHINE
- Please check the overall sizes for possible interferences on some machine models
- Bitte überprüfen sie das ausmass um mögliche interferenzen auf einigen maschinen modellen zu vermeiden

ATTENZIONE - ATTENTION - ACHTUNG

- Per lo smontaggio degli utensili utilizzare sempre la chiave di contrasto come indicato nel manuale d'uso.
- For disassembly of the tools use always the contrast key as mentioned in the user instructions.
- Fuer das Abmontieren der Werkzeuge immer den Gegenschlüssel benutzen wie in der Bedienungsanleitung erwäehnt.

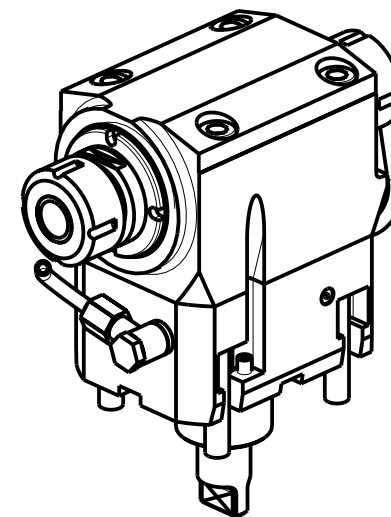

Cod. MT	Cod. MORI-SEIKI	Mandrino Spindle Spindel	I	RPM	Coppia Max Max Torque Max Drehmoment	Reversibile lato mandrino/contromandrino Reversible sub/main spindle side Umkehrbare Spindel-seite/ Gegenspindel-seite	Lubr.esterna Ext. coolant Aussenkuehlung	A	B	CHIAVI NON INCLUSE Keys not included Schluessel nicht einbegriffen	
MNZ0210325	-	ER25+ER25	1:1	6000	40Nm	X	X	85.16	99.16	CHUB36	CHSTER25
MNZ0210332	-	ER32+ER32	1:1	6000	40Nm	X	X	88.16	102.16	CHUB36	CHSTER32

DMG-MORI

NZ1500/2000 - NZX1500/2000 - NT3000 SERIE - NL1500/2000/2500 20 STAZ. - NLX1500/2000/2500 20 STAZ.
 NT1000/2000 - NTX1000/2000 - DURATURN 2050MC/2550MC - ALX1500/2000/2500

MODULO MOTORIZZATO ASSIALE BISPORGENTE H=100mm

Axial opposite face twin driven tool H=100mm

Axial angetriebenes Werkzeug halb vorspringend H=100mm

Subject to change without notice.

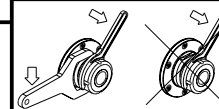

M.T. srl

Via Casino Albini 480
 Tel. 0541/956034-957884
 Fax 0541/956341
 47842 S. GIOVANNI IN M. (RN)
 e-mail: mtma@mtmarchetti.com
 http://www.mtmarchetti.com

PRODUZIONE MODULI ROTANTI



PAGINA MNZ240-1-20

ATTENZIONE - ATTENTION - ACHTUNG

- VERIFICARE LE MISURE DI INGOMBRO PER POSSIBILE INTERFERENZA SU ALCUNI MODELLI DI MACCHINE
- Please check the overall sizes for possible interferences on some machine models
- Bitte überprüfen sie das ausmass um mögliche interferenzen auf einigen maschinen modellen zu vermeiden

ATTENZIONE - ATTENTION - ACHTUNG

- Per lo smontaggio degli utensili utilizzare sempre la chiave di contrasto come indicato nel manuale d'uso.
- For disassembly of the tools use always the contrast key as mentioned in the user instructions.
- Fuer das Abmontieren der Werkzeuge immer den Gegenschlüssel benutzen wie in der Bedienungsanleitung erwaeht.

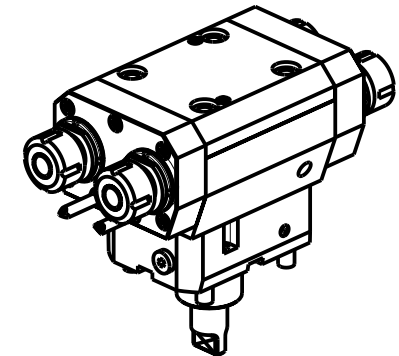
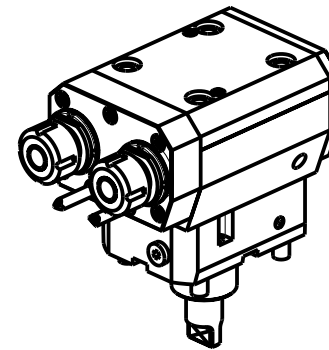
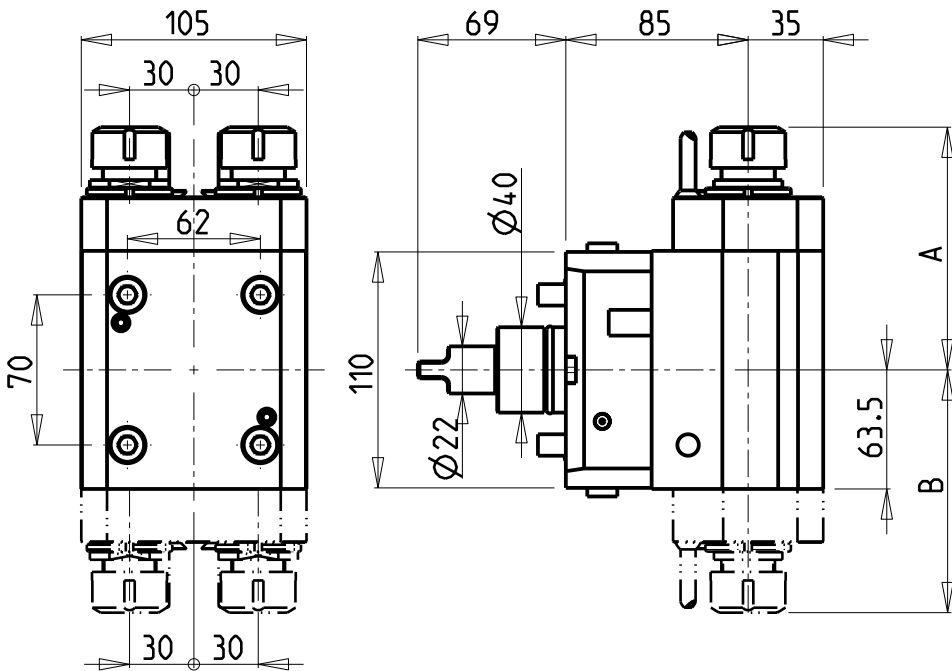

Cod. MT	Mandrino Spindle Spindel	I	RPM	Coppia Max Max Torque Max Drehmoment	N°Utensili N°Tools N°Werkzeuge	Reversibile lato mandrino/contromandrino Reversible sub/main spindle side Umkehrbare Spindel-seite/ Gegenspindel-seite	Lubr.esterna Ext. coolant Aussenkuehlung	A	B	CHIAVI NON INCLUDE Keys not included Schluessel nicht einbegriffen	
										CHUB32	CHUB19_SP3
MNZ0040316	ERA16	1:1	6000	40Nm	2	X	X	96.63	-	CHUB32	CHUB19_SP3
MNZ0040320	ER20	1:1	6000	40Nm	2	X	X	113.16	-	CHUB32	CHSTER20
MNZ0040416	ERA16+ERA16	1:1	6000	40Nm	2+2	X	X	96.63	96.63	CHUB32	CHUB19_SP3
MNZ0040420	ER20+ER20	1:1	6000	40Nm	2+2	X	X	113.16	113.16	CHUB32	CHSTER20

DMG-MORI

NZ1500/2000 - NZX1500/2000 - NT3000 SERIE - NL1500/2000/2500 20 STAZ. - NLX1500/2000/2500 20 STAZ.
 NT1000/2000 - DURATURN 2050MC/2550MC - ALX1500/2000/2500

MODULO MOTORIZZATO ASSIALE 2/4 USCITE IN Y H=85mm

Axial multiple 2/4 outlet driven tool in Y H=85mm

Axial angetriebenes Mehrspindel-Werkzeug 2/4 Ausgaenge in Y H=85mm

Subject to change without notice.

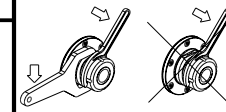

M.T. srl

Via Casino Albini 480
 Tel. 0541/956034-957884
 Fax 0541/956341
 47842 S. GIOVANNI IN M. (RN)
 e-mail: mtma@mtmarchetti.com
 http://www.mtmarchetti.com

PRODUZIONE MODULI ROTANTI



PAGINA MNZ268-1-00

ATTENZIONE - ATTENTION - ACHTUNG

- VERIFICARE LE MISURE DI INGOMBRO PER POSSIBILE INTERFERENZA SU ALCUNI MODELLI DI MACCHINE
- Please check the overall sizes for possible interferences on some machine models
- Bitte überprüfen sie das ausmass um mögliche interferenzen auf einigen maschinen modellen zu vermeiden

ATTENZIONE - ATTENTION - ACHTUNG

- Per lo smontaggio degli utensili utilizzare sempre la chiave di contrasto come indicato nel manuale d'uso.
- For disassembly of the tools use always the contrast key as mentioned in the user instructions.
- Fuer das Abmontieren der Werkzeuge immer den Gegenschlüssel benutzen wie in der Bedienungsanleitung erwaeht.

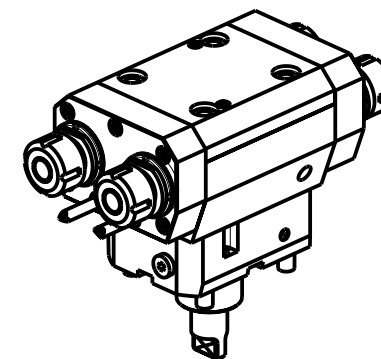
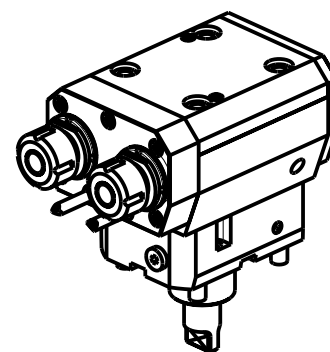
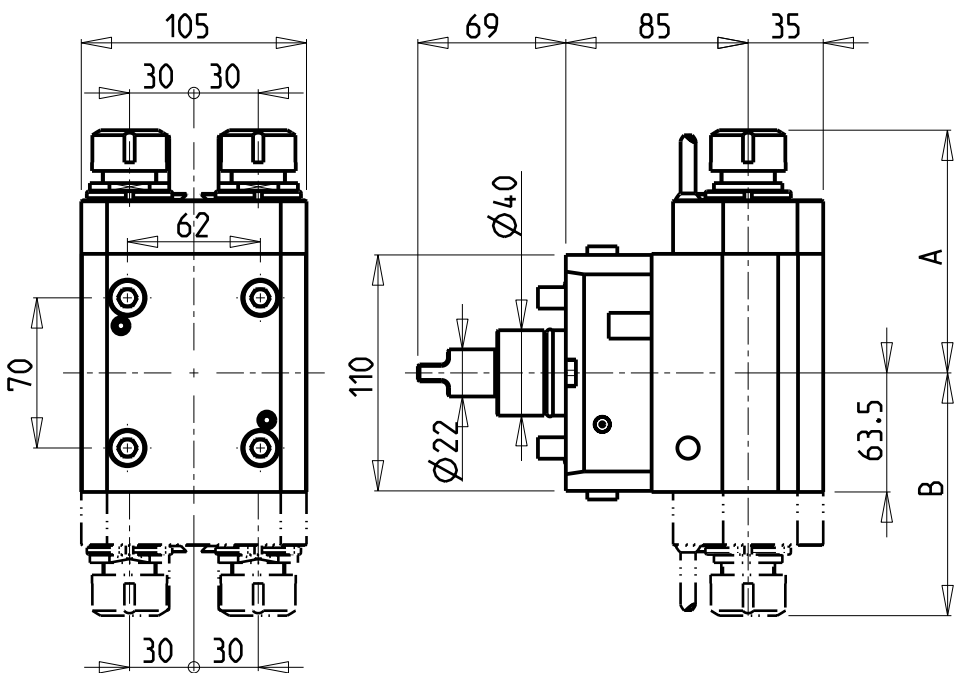

Cod. MT	Mandrino Spindle Spindel	I	RPM	Coppia Max Max Torque Max Drehmoment	N°Utensili N°Tools N°Werkzeuge	Reversibile lato mandrino/contromandrino Reversible sub/main spindle side Umkehrbare Spindel-seite/ Gegenspindel-seite	Lubr.esterna Ext. coolant Aussenkuehlung	A	B	CHIAVI NON INCLUDE Keys not included Schluessel nicht einbegriffen	
										CHUB32	CHUB19_SP3
MNZ0610316	ERA16	1:1	12000	40Nm	2	X	X	96.63	-	CHUB32	CHUB19_SP3
MNZ0610320	ER20	1:1	12000	40Nm	2	X	X	113.16	-	CHUB32	CHSTER20
MNZ0610416	ERA16+ERA16	1:1	12000	40Nm	2+2	X	X	96.63	96.63	CHUB32	CHUB19_SP3
MNZ0610420	ER20+ER20	1:1	12000	40Nm	2+2	X	X	113.16	113.16	CHUB32	CHSTER20

DMG-MORI

NZ1500/2000 - NZX1500/2000 - NL1500/2000/2500 20 STAZ. - NLX1500/2000/2500 20 STAZ. - NTX1000/2000

MODULO MOTORIZZATO ASSIALE 2/4 USCITE IN Y 12000 RPM H=85mm

Axial multiple 2/4 outlet driven tool in Y 12000 rpm H=85mm

Axial angetriebenes Mehrspindel-Werkzeug 2/4 Ausgaenge in Y 12000 rpm H=85mm

Subject to change without notice.

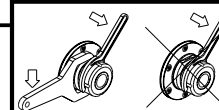

M.T. srl

Via Casino Albini 480
Tel. 0541/956034-957884
Fax 0541/956341
47842 S. GIOVANNI IN M. (RN)
e-mail: mtma@mtmarchetti.com
http://www.mtmarchetti.com

PRODUZIONE MODULI ROTANTI



PAGINA MNZ268-1-01

ATTENZIONE - ATTENTION - ACHTUNG

- VERIFICARE LE MISURE DI INGOMBRO PER POSSIBILE INTERFERENZA SU ALCUNI MODELLI DI MACCHINE
- Please check the overall sizes for possible interferences on some machine models
- Bitte überprüfen sie das ausmass um mögliche interferenzen auf einigen maschinen modellen zu vermeiden

ATTENZIONE - ATTENTION - ACHTUNG

- Per lo smontaggio degli utensili utilizzare sempre la chiave di contrasto come indicato nel manuale d'uso.
- For disassembly of the tools use always the contrast key as mentioned in the user instructions.
- Fuer das Abmontieren der Werkzeuge immer den Gegenschlüssel benutzen wie in der Bedienungsanleitung erwaeht.

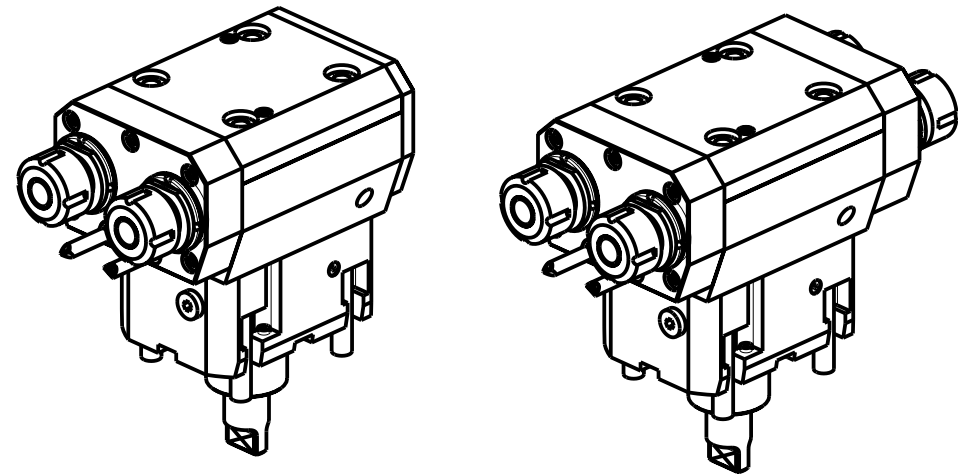
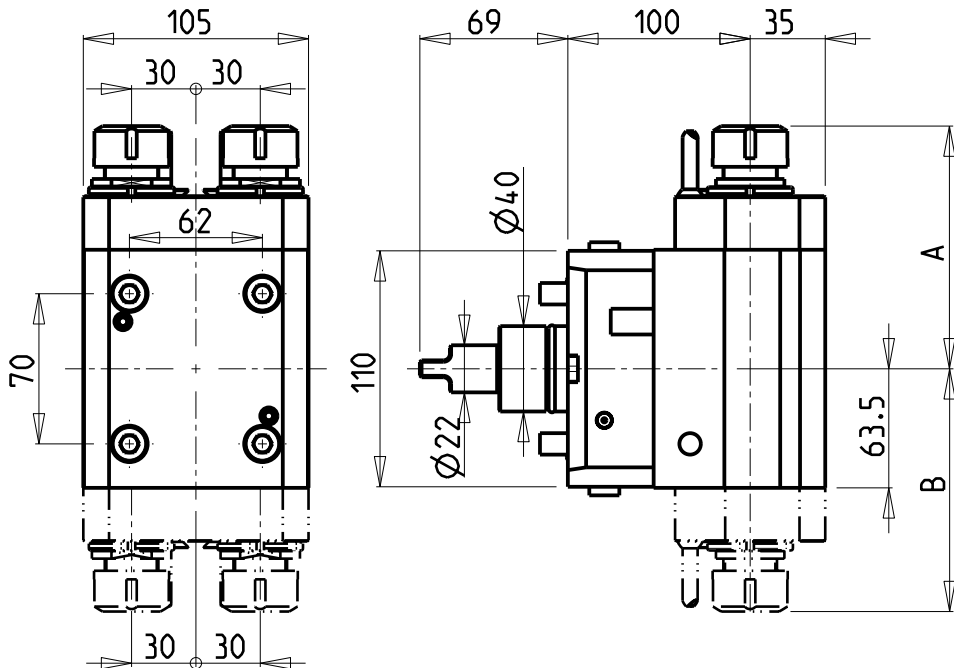

Cod. MT	Mandrino Spindle Spindel	I	RPM	Coppia Max Max Torque Max Drehmoment	N°Utensili N°Tools N°Werkzeuge	Reversibile lato mandrino/contromandrino Reversible sub/main spindle side Umkehrbare Spindelseite/ Gegenspindelseite	Lubr.esterna Ext. coolant Aussenkuehlung	A	B	CHIAVI NON INCLUSE Keys not included Schluessel nicht einbegriffen	
MNZ0041316	ERA16	1:1	6000	40Nm	2	X	X	96.63	-	CHUB32	CHUB19_SP3
MNZ0041320	ER20	1:1	6000	40Nm	2	X	X	113.16	-	CHUB32	CHSTER20
MNZ0041416	ERA16+ERA16	1:1	6000	40Nm	2+2	X	X	96.63	96.63	CHUB32	CHUB19_SP3
MNZ0041420	ER20+ER20	1:1	6000	40Nm	2+2	X	X	113.16	113.16	CHUB32	CHSTER20

DMG-MORI

NZ1500/2000 - NZX1500/2000 - NT3000 SERIE - NL1500/2000/2500 20 STAZ. - NLX1500/2000/2500 20 STAZ.
 NT1000/2000 - DURATURN 2050MC/2550MC - ALX1500/2000/2500

MODULO MOTORIZZATO ASSIALE 2/4 USCITE IN Y H=100mm

Axial multiple 2/4 outlet driven tool in Y H=100mm

Axial angetriebenes Mehrspindel-Werkzeug 2/4 Ausgaenge in Y H=100mm

Subject to change without notice.

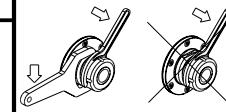

M.T. srl

Via Casino Albini 480
 Tel. 0541/956034-957884
 Fax 0541/956341
 47842 S. GIOVANNI IN M. (RN)
 e-mail: mtma@mtmarchetti.com
 http://www.mtmarchetti.com

PRODUZIONE MODULI ROTANTI



PAGINA MNZ268-1-10

ATTENZIONE - ATTENTION - ACHTUNG

- VERIFICARE LE MISURE DI INGOMBRO PER POSSIBILE INTERFERENZA SU ALCUNI MODELLI DI MACCHINE
- Please check the overall sizes for possible interferences on some machine models
- Bitte überprüfen sie das ausmass um mögliche interferenzen auf einigen maschinen modellen zu vermeiden

ATTENZIONE - ATTENTION - ACHTUNG

- Per lo smontaggio degli utensili utilizzare sempre la chiave di contrasto come indicato nel manuale d'uso.
- For disassembly of the tools use always the contrast key as mentioned in the user instructions.
- Fuer das Abmontieren der Werkzeuge immer den Gegenschlüssel benutzen wie in der Bedienungsanleitung erwaeht.

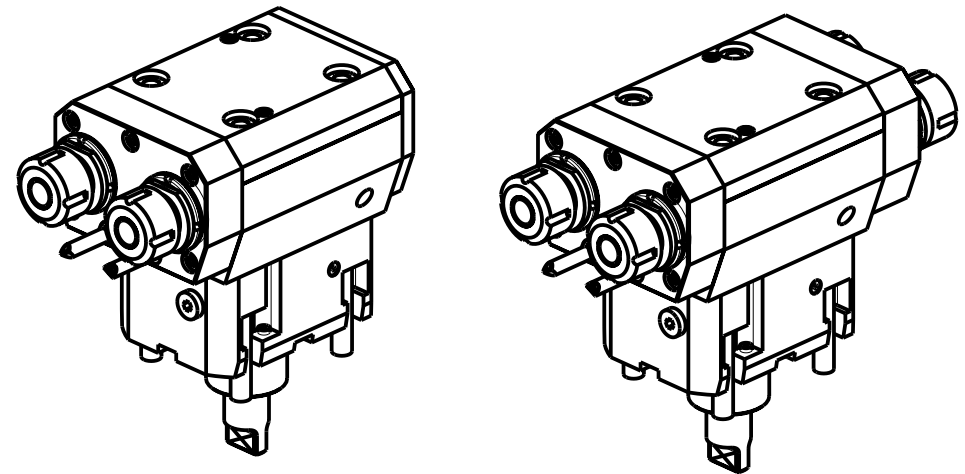
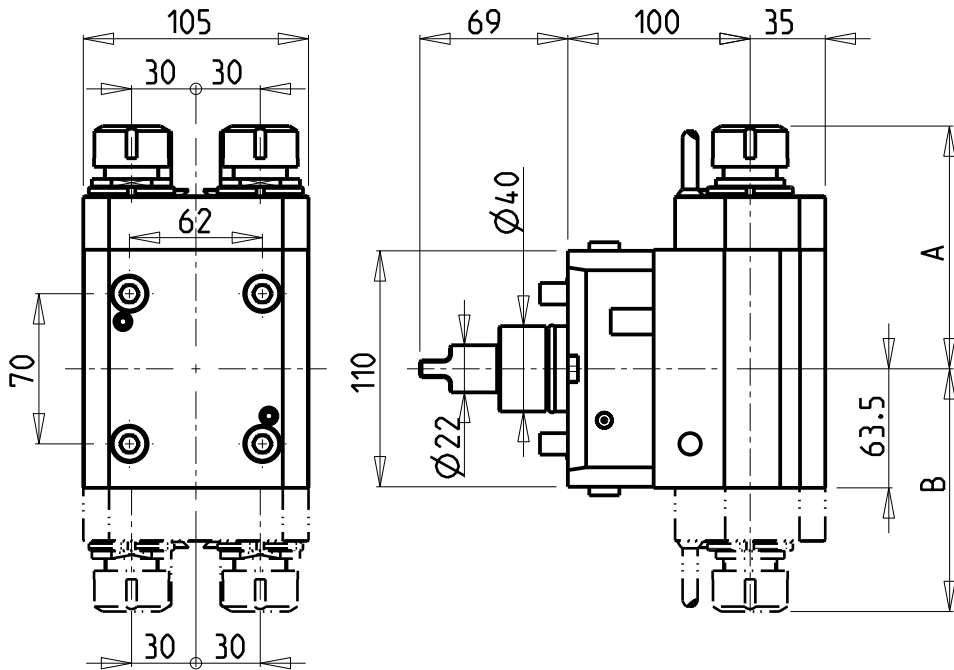

Cod. MT	Mandrino Spindle Spindel	I	RPM	Coppia Max Max Torque Max Drehmoment	N°Utensili N°Tools N°Werkzeuge	Reversibile lato mandrino/contromandrino Reversible sub/main spindle side Umkehrbare Spindel-seite/ Gegenspindel-seite	Lubr.esterna Ext. coolant Aussenkuehlung	A	B	CHIAVI NON INCLUSE Keys not included Schluessel nicht einbegriffen	
MNZ0611316	ERA16	1:1	12000	40Nm	2	X	X	96.63	-	CHUB32	CHUB19_SP3
MNZ0611320	ER20	1:1	12000	40Nm	2	X	X	113.16	-	CHUB32	CHSTER20
MNZ0611416	ERA16+ERA16	1:1	12000	40Nm	2+2	X	X	96.63	96.63	CHUB32	CHUB19_SP3
MNZ0611420	ER20+ER20	1:1	12000	40Nm	2+2	X	X	113.16	113.16	CHUB32	CHSTER20

DMG-MORI

NZ1500/2000 - NZX1500/2000 - NL1500/2000/2500 20 STAZ. - NLX1500/2000/2500 20 STAZ. - NTX1000/2000

MODULO MOTORIZZATO ASSIALE 2/4 USCITE IN Y 12000 RPM H=100mm

Axial multiple 2/4 outlet driven tool in Y 12000 rpm H=100mm

Axial angetriebenes Mehrspindel-Werkzeug 2/4 Ausgaenge in Y 12000 rpm H=100mm

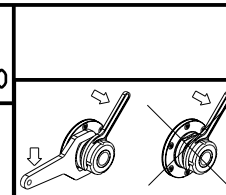

M.T. srl

Via Casino Albini 480
Tel. 0541/956034-957884
Fax 0541/956341
47842 S. GIOVANNI IN M. (RN)
e-mail: mtma@mtmarchetti.com
http://www.mtmarchetti.com

PRODUZIONE MODULI ROTANTI



PAGINA MNZ268-1-11

Subject to change without notice.

10/2018

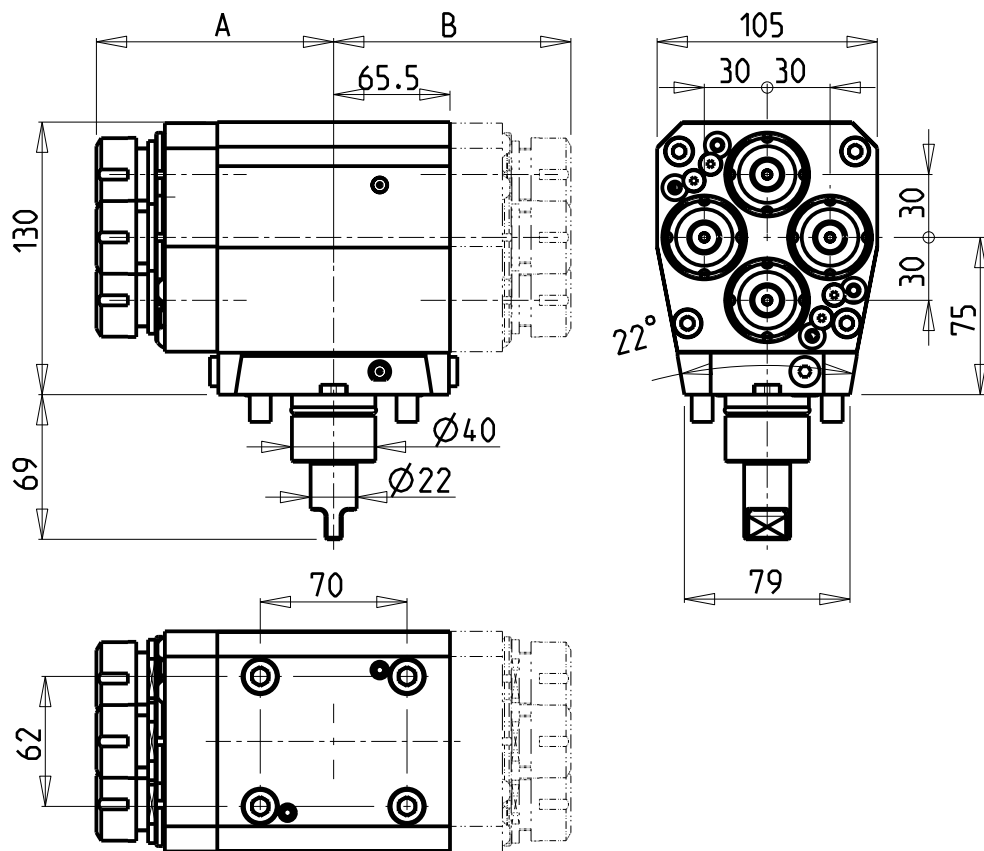

ATTENZIONE - ATTENTION - ACHTUNG

- VERIFICARE LE MISURE DI INGOMBRO PER POSSIBILE INTERFERENZA SU ALCUNI MODELLI DI MACCHINE
- Please check the overall sizes for possible interferences on some machine models
- Bitte überprüfen sie das ausmass um mögliche interferenzen auf einigen maschinen modellen zu vermeiden

ATTENZIONE - ATTENTION - ACHTUNG

- Per lo smontaggio degli utensili utilizzare sempre la chiave di contrasto come indicato nel manuale d'uso.
- For disassembly of the tools use always the contrast key as mentioned in the user instructions.
- Fuer das Abmontieren der Werkzeuge immer den Gegenschlüssel benutzen wie in der Bedienungsanleitung erwäehnt.

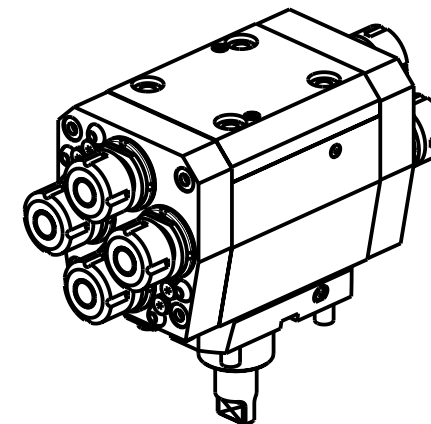
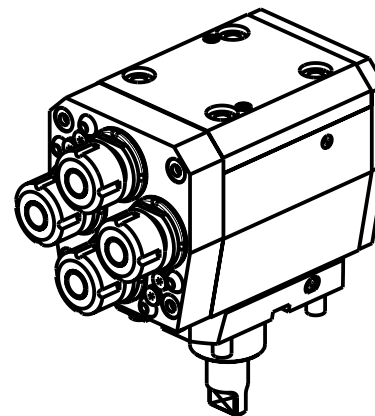

Cod. MT	Mandrino Spindle Spindel	I	RPM	Coppia Max Max Torque Max Drehmoment	N°Utensili N°Tools N°Werkzeuge	Reversibile lato mandrino/contromandrino Reversible sub/main spindle side Umkehrbare Spindel-seite/ Gegenspindel-seite	Lubr.esterna Ext. coolant Aussenkuehlung	A	B	CHIAVI INCLUSE Keys included Schluessel einbegriffen	
MNZ0040116	ER A 16	1:1	6000	30Nm	4	X	X	96.63	-	CHUB32	CHUB19_SP3
MNZ0040120	ER20	1:1	6000	30Nm	4	X	X	113.16	-	CHUB32	CHSTER20
MNZ0040216	ERA16+ERA16	1:1	6000	30Nm	4+4	X	X	96.63	96.63	CHUB32	CHUB19_SP3
MNZ0040220	ER20+ER20	1:1	6000	30Nm	4+4	X	X	113.16	113.16	CHUB32	CHSTER20

DMG-MORI

NZ1500/2000 - NZX1500/2000 - NT3000 SERIE - NL1500/2000/2500 20 STAZ. - NLX1500/2000/2500 20 STAZ.
DURATURN 2050MC/2550MC

MODULO MOTORIZZATO ASSIALE 4/8 USCITE

Axial multiple 4/8 outlet driven tool

Axial angetriebenes Mehrspindel-Werkzeug 4/8 Ausgaenge

Subject to change without notice.

M.T. srl

Via Casino Albini 480
Tel. 0541/956034-957884
Fax 0541/956341
47842 S. GIOVANNI IN M. (RN)
e-mail: mtma@mtmarchetti.com
http://www.mtmarchetti.com

PRODUZIONE MODULI ROTANTI



PAGINA MNZ270-1-00

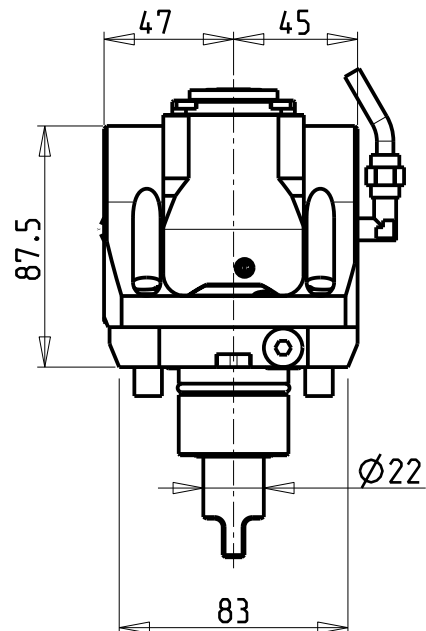
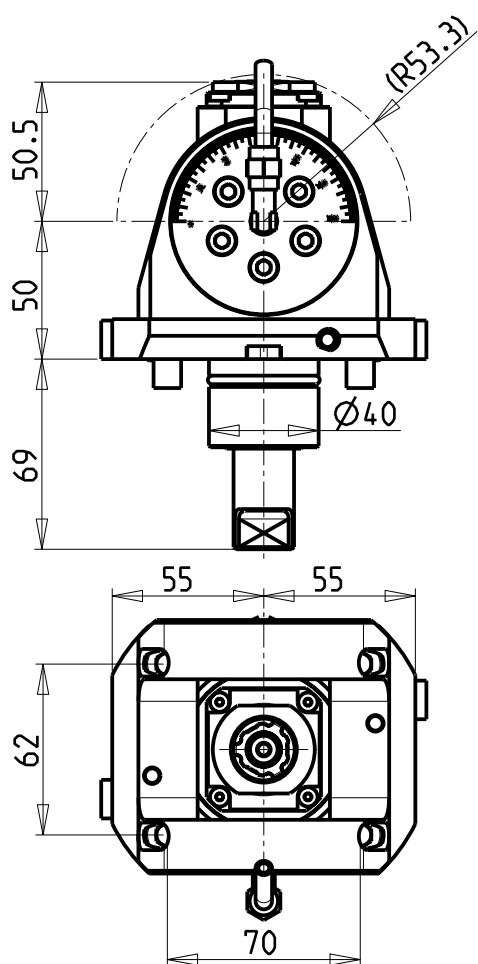

ATTENZIONE - ATTENTION - ACHTUNG

- Per lo smontaggio degli utensili utilizzare sempre la chiave di contrasto come indicato nel manuale d'uso.
- For disassembly of the tools use always the contrast key as mentioned in the user instructions.
- Fuer das Abmontieren der Werkzeuge immer den Gegenschlüssel benutzen wie in der Bedienungsanleitung erwäehnt.

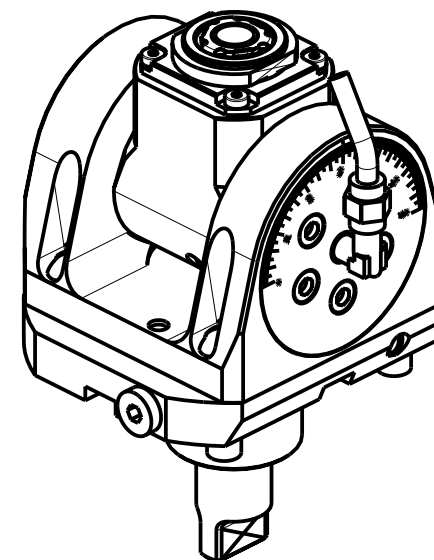

Cod. MT	Mandrino Spindle Spindel	I	RPM	Coppia Max Max Torque Max Drehmoment	Lubrificazione int. Coolant through Innenkuehlung	Lubrificazione est. Ext. coolant Aussenkuehlung	CHIAVI INCLUSE Keys included Schluessel inbegriffen			
MNZ0390120	ER A 20	1:1	6000	30Nm		X	CHUB36	CHUB22	CHESLO8	CHTAER20ZC
MNZ0390220	ER A 20	1:1	6000	30Nm	P=70bar	X	CHUB36	CHUB22	CHESLO8	CHTAER20ZC

DMG-MORI
 NZ1500/2000 - NZX1500/2000 - NT3000 SERIE - NT1000/2000 - NTX1000/2000 - NTX1000/2000/2500/3000 2ND GEN. 12ST.
 DURATURN 2050MC/2550MC - NRX2000 - ALX1500/2000/2500

MODULO MOTORIZZATO ORIENTABILE +/-90° H=50mm
 +/-90° adjustable angle driven tool H=50mm
 Angetriebenes Werkzeug schwenkbar +/-90° H=50mm

Subject to change without notice.

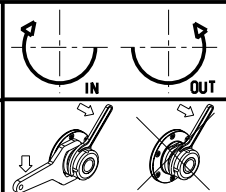

M.T. srl
 Via Casino Albini 480
 Tel. 0541/956034-957884
 Fax 0541/956341
 47842 S. GIOVANNI IN M. (RN)
 e-mail: mtma@mtmarchetti.com
 http://www.mtmarchetti.com

PRODUZIONE MODULI ROTANTI



PAGINA MNZ335-1-00

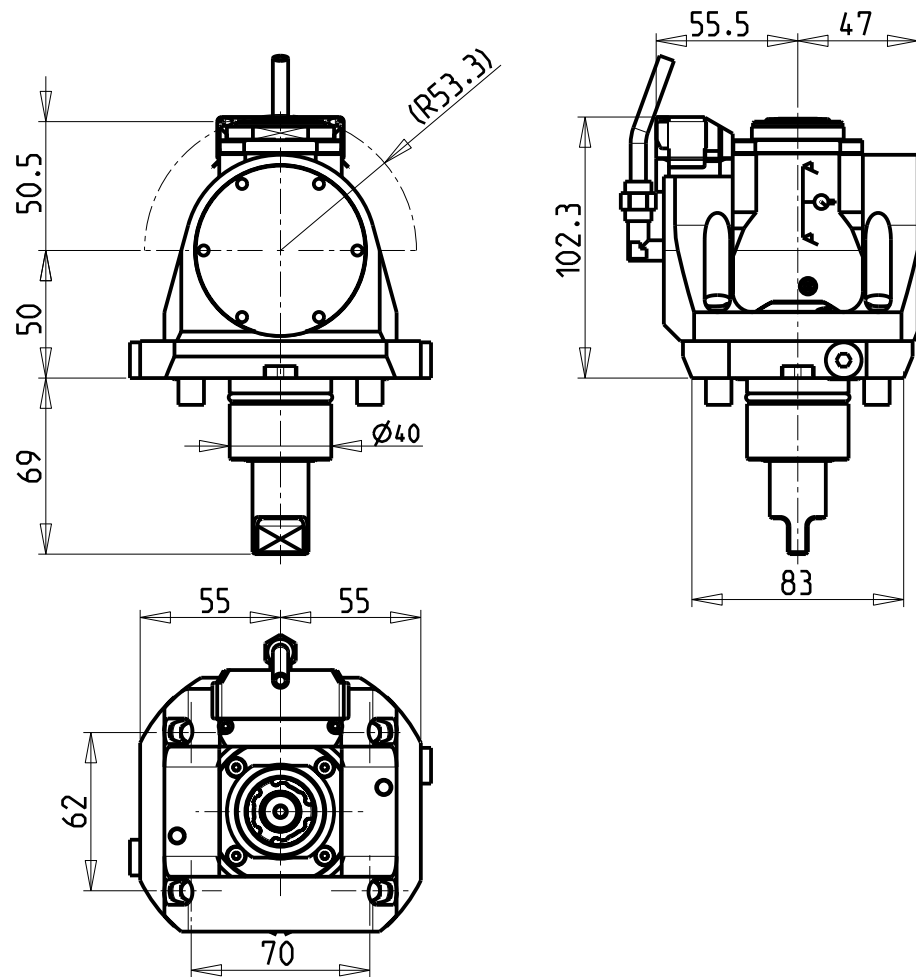

ATTENZIONE - ATTENTION - ACHTUNG

- Per lo smontaggio degli utensili utilizzare sempre la chiave di contrasto come indicato nel manuale d'uso.
- For disassembly of the tools use always the contrast key as mentioned in the user instructions.
- Fuer das Abmontieren der Werkzeuge immer den Gegenschlüssel benutzen wie in der Bedienungsanleitung erwäohnt.

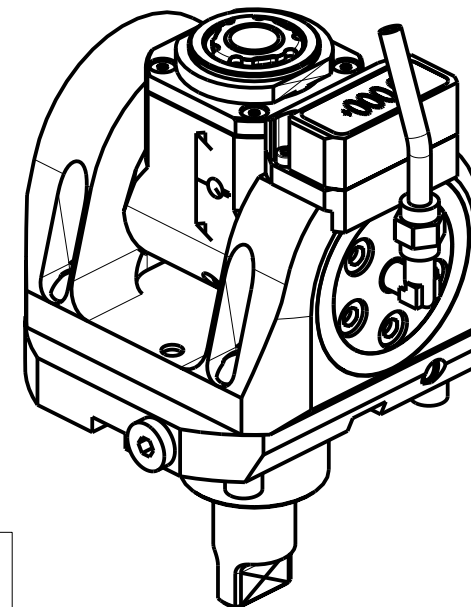

Cod. MT	Mandrino Spindle Spindel	I	RPM	Coppia Max Max Torque Max Drehmoment	Lubrificazione int. Coolant through Innenkuehlung	Lubrificazione est. Ext. coolant Aussenkuehlung	CHIAVI INCLUSE Keys included Schluessel inbegriffen			
MNZ0395120	ER A 20	1:1	6000	30Nm	-	X	CHUB36	CHUB22	CHESLO8	CHTAER20ZC
MNZ0395220	ER A 20	1:1	6000	30Nm	P=70bar	X	CHUB36	CHUB22	CHESLO8	CHTAER20ZC

DMG-MORI

NZ1500/2000 - NZX1500/2000 - NT3000 SERIE - NT1000/2000 - NTX1000/2000 - NTX1000/2000/2500/3000 2ND GEN. 12ST.
DURATURN 2050MC/2550MC - NRX2000 - ALX1500/2000/2500

MODULO MOTORIZZATO ORIENTABILE +/-90° CON NONIO DIGITALE H=50mm

+/-90° adjustable angle driven tool with digital display H=50mm

Angetriebenes Werkzeug schwenkbar +/-90° mit digital display H=50mm

Subject to change without notice.

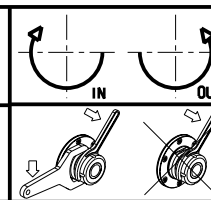

M.T. srl

Via Casino Albini 480
Tel. 0541/956034-957884
Fax 0541/956341
47842 S. GIOVANNI IN M. (RN)
e-mail: mtma@mtmarchetti.com
<http://www.mtmarchetti.com>

PRODUZIONE MODULI ROTANTI



PAGINA MNZ335-1-01

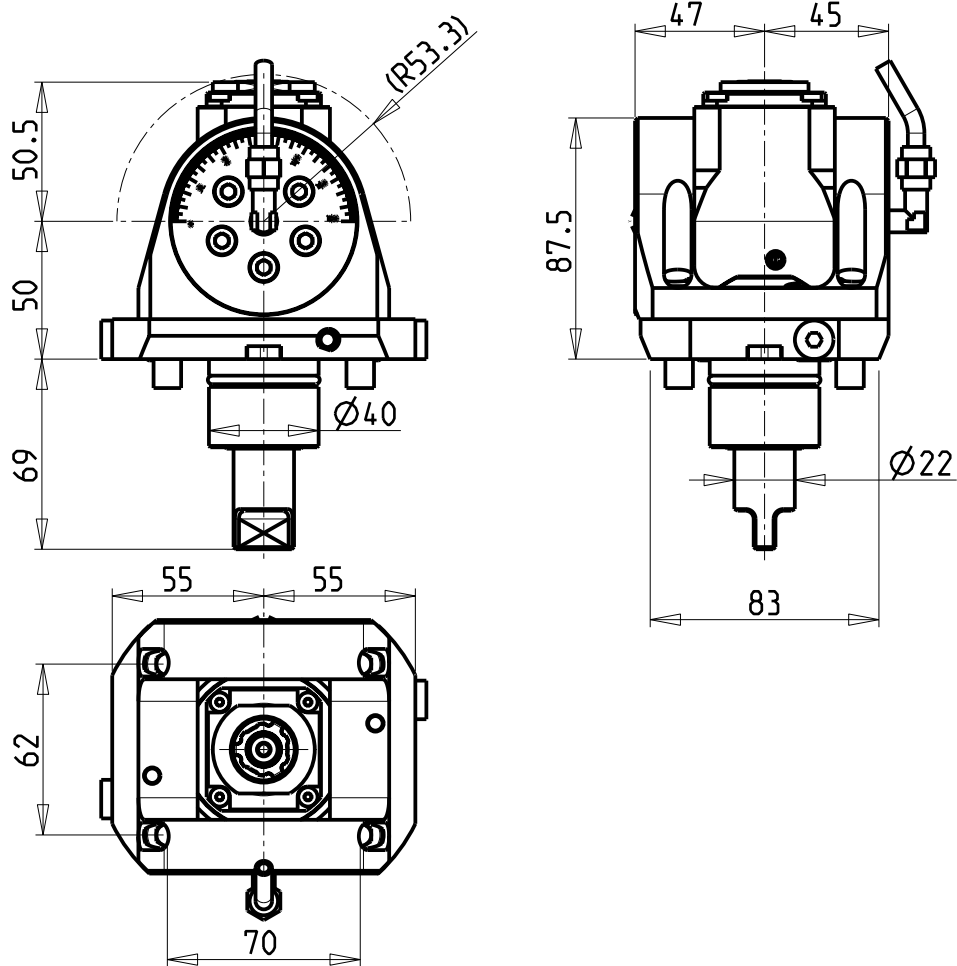

ATTENZIONE - ATTENTION - ACHTUNG

- Per lo smontaggio degli utensili utilizzare sempre la chiave di contrasto come indicato nel manuale d'uso.
- For disassembly of the tools use always the contrast key as mentioned in the user instructions.
- Fuer das Abmontieren der Werkzeuge immer den Gegenschlüssel benutzen wie in der Bedienungsanleitung erwäehnt.

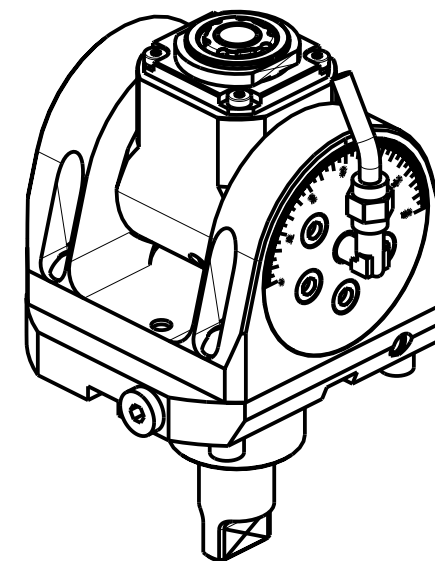

Cod. MT	Mandrino Spindle Spindel	I	RPM	Coppia Max Max Torque Max Drehmoment	Lubrificazione int. Coolant through Innenkuehlung	Lubrificazione est. Ext. coolant Aussenkuehlung	CHIAVI INCLUSE Keys included Schluessel inbegriffen			
MNZ0580120	ER A 20	1:1	12000	30Nm	-	X	CHUB36	CHUB22	CHESLO8	CHTAER20ZC
MNZ0580220	ER A 20	1:1	12000	30Nm	P=70bar	X	CHUB36	CHUB22	CHESLO8	CHTAER20ZC

DMG-MORI

NZ1500/2000 - NZX1500/2000 - NTX1000/2000 - NTX1000/2000/2500/3000 2ND GEN. 12ST. - NRX2000

MODULO MOTORIZZATO ORIENTABILE +/-90° 12000 RPM H=50mm

+/-90° adjustable angle driven tool 12000 rpm H=50mm

Angetriebenes Werkzeug schwenkbar +/-90° 12000 rpm H=50mm

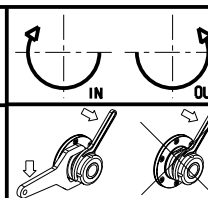

M.T. srl

Via Casino Albini 480
Tel. 0541/956034-957884
Fax 0541/956341
47842 S. GIOVANNI IN M. (RN)
e-mail: mtma@mtmarchetti.com
http://www.mtmarchetti.com

PRODUZIONE MODULI ROTANTI



PAGINA MNZ335-1-02

Subject to change without notice.

10/2018

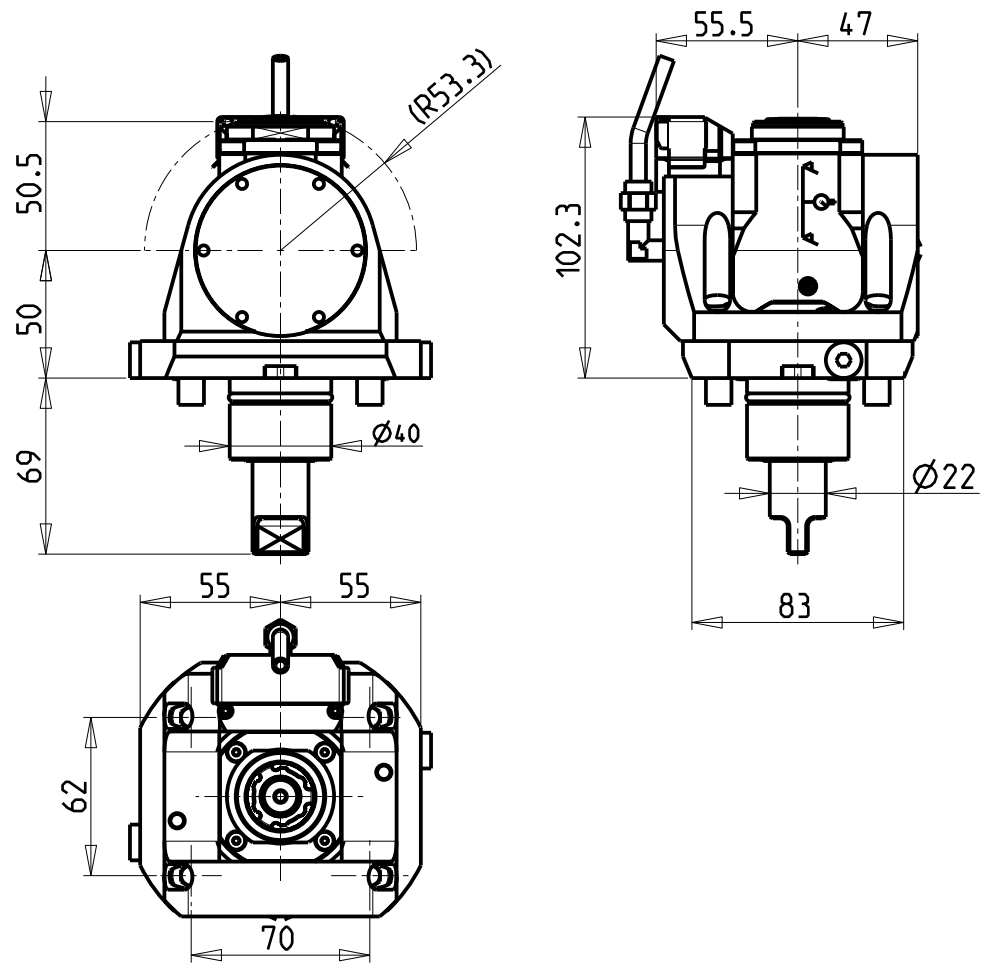

ATTENZIONE - ATTENTION - ACHTUNG

- Per lo smontaggio degli utensili utilizzare sempre la chiave di contrasto come indicato nel manuale d'uso.
- For disassembly of the tools use always the contrast key as mentioned in the user instructions.
- Fuer das Abmontieren der Werkzeuge immer den Gegenschlüssel benutzen wie in der Bedienungsanleitung erwäohnt.

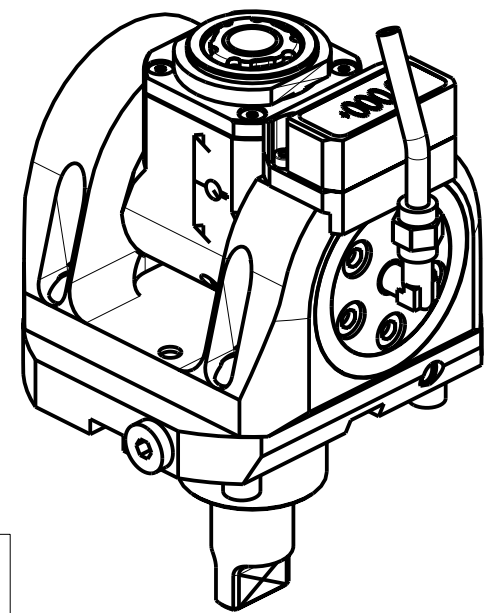

Cod. MT	Mandrino Spindle Spindel	I	RPM	Coppia Max Max Torque Max Drehmoment	Lubrificazione int. Coolant through Innenkuehlung	Lubrificazione est. Ext. coolant Aussenkuehlung	CHIAVI INCLUSE Keys included Schluessel inbegriffen			
MNZ0585120	ER A 20	1:1	12000	30Nm	-	X	CHUB36	CHUB22	CHESLO8	CHTAER20ZC
MNZ0585220	ER A 20	1:1	12000	30Nm	P=70bar	X	CHUB36	CHUB22	CHESLO8	CHTAER20ZC

DMG-MORI
 NZ1500/2000 - NZX1500/2000 - NTX1000/2000 - NTX1000/2000/2500/3000 2ND GEN. 12ST. - NRX2000

MODULO MOTORIZZATO ORIENTABILE +/-90° 12000 RPM CON NONIO DIGITALE H=50mm
 +/-90° adjustable angle driven tool 12000 rpm with digital display H=50mm
 Angetriebenes Werkzeug schwenkbar +/-90° 12000 rpm mit digital display H=50mm

Subject to change without notice.

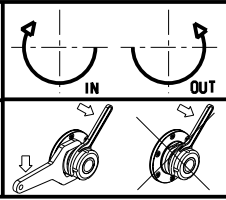

M.T. srl
 Via Casino Albini 480
 Tel. 0541/956034-957884
 Fax 0541/956341
 47842 S. GIOVANNI IN M. (RN)
 e-mail: mtma@mtmarchetti.com
 http://www.mtmarchetti.com

PRODUZIONE MODULI ROTANTI

PAGINA MNZ335-1-03

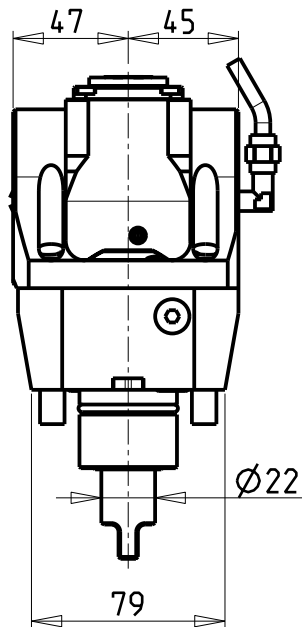
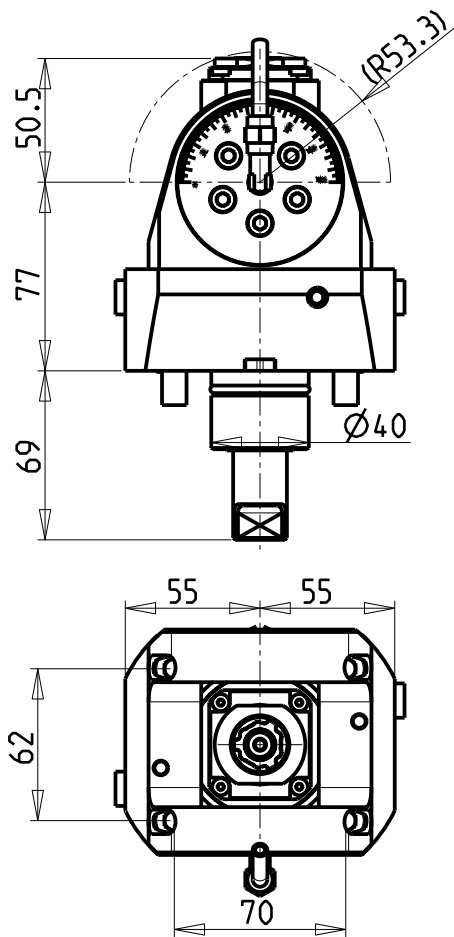

ATTENZIONE - ATTENTION - ACHTUNG

- VERIFICARE LE MISURE DI INGOMBRO PER POSSIBILE INTERFERENZA SU ALCUNI MODELLI DI MACCHINE
- Please check the overall sizes for possible interferences on some machine models
- Bitte überprüfen sie das ausmass um mögliche interferenzen auf einigen maschinen modellen zu vermeiden

ATTENZIONE - ATTENTION - ACHTUNG

- Per lo smontaggio degli utensili utilizzare sempre la chiave di contrasto come indicato nel manuale d'uso.
- For disassembly of the tools use always the contrast key as mentioned in the user instructions.
- Fuer das Abmontieren der Werkzeuge immer den Gegenschlüssel benutzen wie in der Bedienungsanleitung erwaeht.

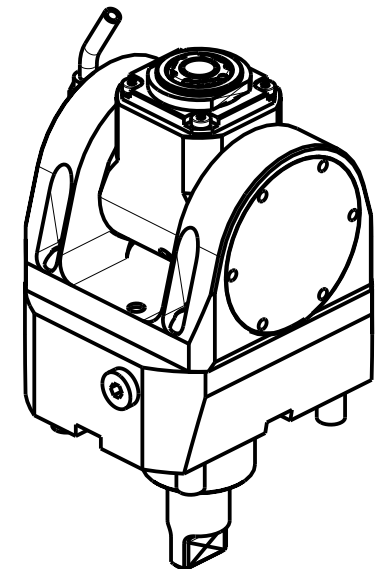
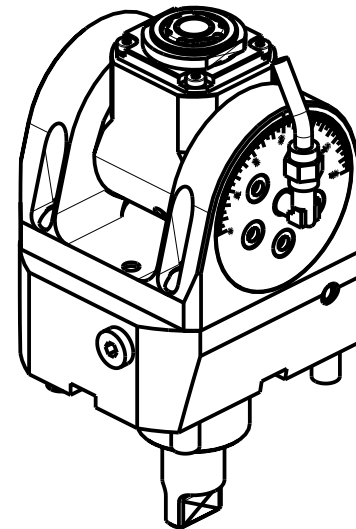

Cod. MT	Mandrino Spindle Spindel	I	RPM	Coppia Max Max Torque Max Drehmoment	Lubrificazione int. Coolant through Innenkuehlung	Lubrificazione est. Ext. coolant Aussenkuehlung	CHIAVI INCLUSE Keys included Schlüssel inbegriffen			
MNZ0391120	ER A 20	1:1	6000	30Nm		X	CHUB36	CHUB22	CHESL08	CHTAER20ZC
MNZ0391220	ER A 20	1:1	6000	30Nm	P=70bar	X	CHUB36	CHUB22	CHESL08	CHTAER20ZC

DMG-MORI

NZ1500/2000 - NZX1500/2000 - NT3000 SERIE - NL1500/2000/2500 20 STAZ. - NLX1500/2000/2500 20 STAZ.
 NT1000/2000 - NTX1000/2000 - NTX1000/2000/2500/3000 2ND GEN. 12ST. - DURATURN 2050MC/2550MC - NRX2000 - ALX1500/2000/2500

MODULO MOTORIZZATO ORIENTABILE +/-90° H=77mm

+/-90° adjustable angle driven tool H=77mm

Angetriebenes Werkzeug schwenkbar +/-90° H=77mm

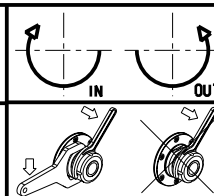

M.T. srl

Via Casino Albini 480
 Tel. 0541/956034-957884
 Fax 0541/956341
 47842 S. GIOVANNI IN M. (RN)
 e-mail: mtma@mtmarchetti.com
 http://www.mtmarchetti.com

PRODUZIONE MODULI ROTANTI



PAGINA MNZ335-1-10

Subject to change without notice.

10/2018

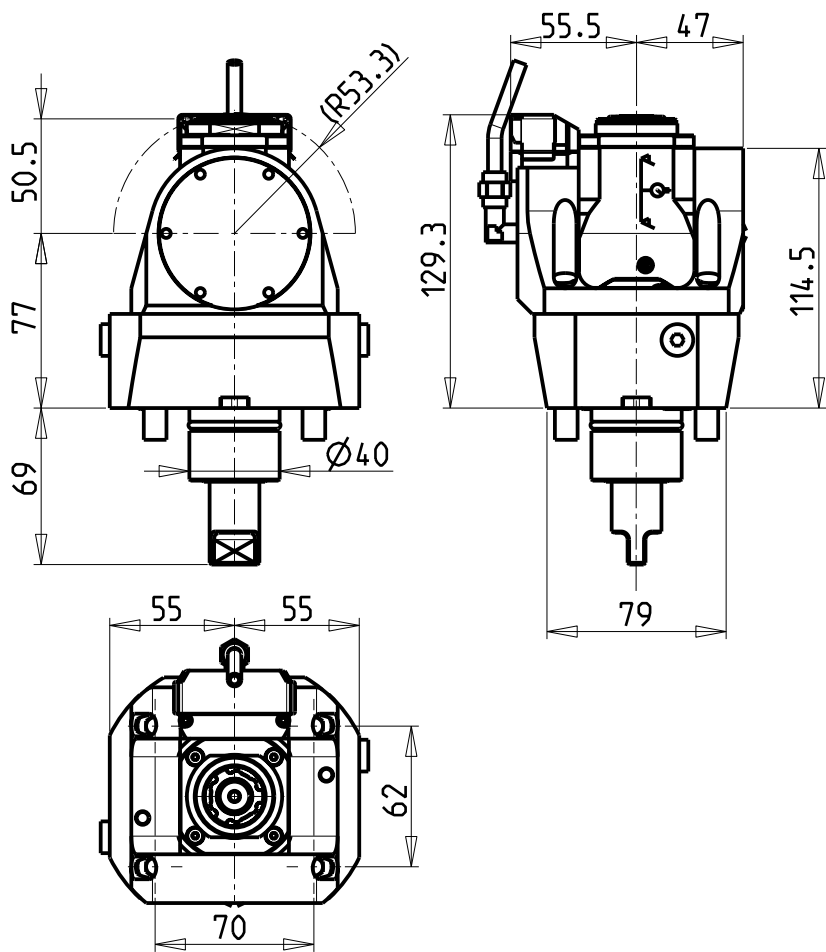

ATTENZIONE - ATTENTION - ACHTUNG

- VERIFICARE LE MISURE DI INGOMBRO PER POSSIBILE INTERFERENZA SU ALCUNI MODELLI DI MACCHINE
- Please check the overall sizes for possible interferences on some machine models
- Bitte überprüfen sie das ausmass um mögliche interferenzen auf einigen maschinen modellen zu vermeiden

ATTENZIONE - ATTENTION - ACHTUNG

- Per lo smontaggio degli utensili utilizzare sempre la chiave di contrasto come indicato nel manuale d'uso.
- For disassembly of the tools use always the contrast key as mentioned in the user instructions.
- Fuer das Abmontieren der Werkzeuge immer den Gegenschlüssel benutzen wie in der Bedienungsanleitung erwaeht.

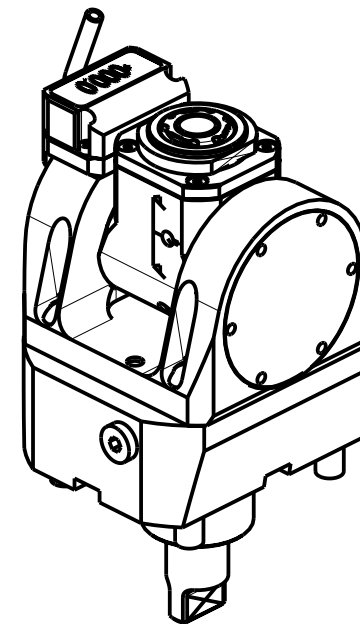
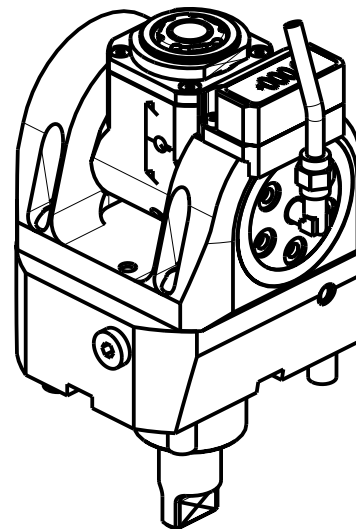

Cod. MT	Mandrino Spindle Spindel	I	RPM	Coppia Max Max Torque Max Drehmoment	Lubrificazione int. Coolant through Innenkuehlung	Lubrificazione est. Ext. coolant Aussenkuehlung	CHIAVI INCLUSE Keys included Schlüssel inbegriffen			
MNZ0396120	ER A 20	1:1	6000	30Nm	-	X	CHUB36	CHUB22	CHESL08	CHTAER20ZC
MNZ0396220	ER A 20	1:1	6000	30Nm	P=70bar	X	CHUB36	CHUB22	CHESL08	CHTAER20ZC

DMG-MORI

NZ1500/2000 - NZX1500/2000 - NT3000 SERIE - NL1500/2000/2500 20 STAZ. - NLX1500/2000/2500 20 STAZ.
 NT1000/2000 - NTX1000/2000 - NTX1000/2000/2500/3000 2ND GEN. 12ST. - DURATURN 2050MC/2550MC - ALX1500/2000/2500

MODULO MOTORIZZATO ORIENTABILE +/-90° CON NONIO DIGITALE H=77mm

+/-90° adjustable angle driven tool with digital display H=77mm

Angetriebenes Werkzeug schwenkbar +/-90° mit digital display H=77mm

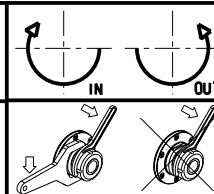

M.T. srl

Via Casino Albini 480
 Tel. 0541/956034-957884
 Fax 0541/956341
 47842 S. GIOVANNI IN M. (RN)
 e-mail: mtma@mtmarchetti.com
 http://www.mtmarchetti.com

PRODUZIONE MODULI ROTANTI



PAGINA MNZ335-1-11

Subject to change without notice.

10/2018

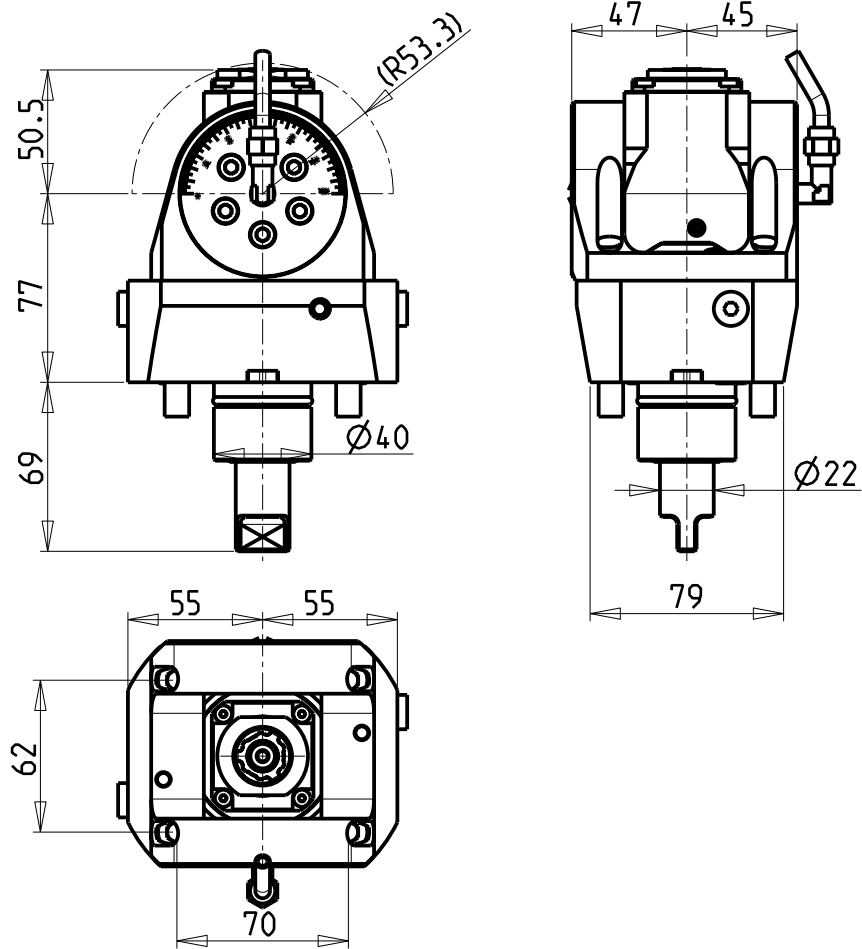

ATTENZIONE - ATTENTION - ACHTUNG

- VERIFICARE LE MISURE DI INGOMBRO PER POSSIBILE INTERFERENZA SU ALCUNI MODELLI DI MACCHINE
- Please check the overall sizes for possible interferences on some machine models
- Bitte überprüfen sie das ausmass um mögliche interferenzen auf einigen maschinen modellen zu vermeiden

ATTENZIONE - ATTENTION - ACHTUNG

- Per lo smontaggio degli utensili utilizzare sempre la chiave di contrasto come indicato nel manuale d'uso.
- For disassembly of the tools use always the contrast key as mentioned in the user instructions.
- Fuer das Abmontieren der Werkzeuge immer den Gegenschlüssel benutzen wie in der Bedienungsanleitung erwaeht.

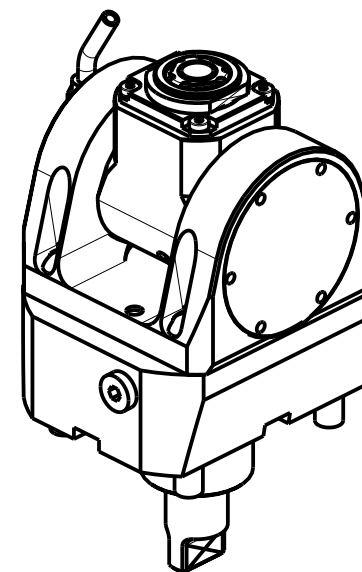
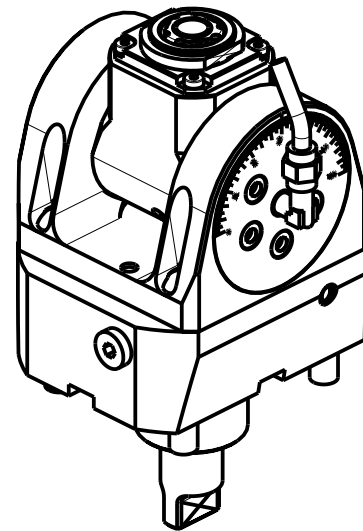

Cod. MT	Mandrino Spindle Spindel	I	RPM	Coppia Max Max Torque Max Drehmoment	Lubrificazione int. Coolant through Innenkuehlung	Lubrificazione est. Ext. coolant Aussenkuehlung	CHIAVI INCLUSE Keys included Schlüssel inbegriffen			
							CHUB36	CHUB22	CHESL08	CHTAER20ZC
MNZ0581120	ER A 20	1:1	12000	30Nm	-	X	CHUB36	CHUB22	CHESL08	CHTAER20ZC
MNZ0581220	ER A 20	1:1	12000	30Nm	P=70bar	X	CHUB36	CHUB22	CHESL08	CHTAER20ZC

DMG-MORI

NZ1500/2000 - NZX1500/2000 - NL1500/2000/2500 20 STAZ. - NLX1500/2000/2500 20 STAZ.
NTX1000/2000 - NTX1000/2000/2500/3000 2ND GEN. 12ST. - NRX2000

MODULO MOTORIZZATO ORIENTABILE +/-90° 12000 RPM H=77mm

+/-90° adjustable angle driven tool 12000 rpm H=77mm

Angetriebenes Werkzeug schwenkbar +/-90° 12000 rpm H=77mm

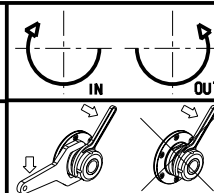

M.T. srl

Via Casino Albini 480
Tel. 0541/956034-957884

Fax 0541/956341

47842 S. GIOVANNI IN M. (RN)
e-mail: mtma@mtmarchetti.com
http://www.mtmarchetti.com

PRODUZIONE MODULI ROTANTI



PAGINA MNZ335-1-12

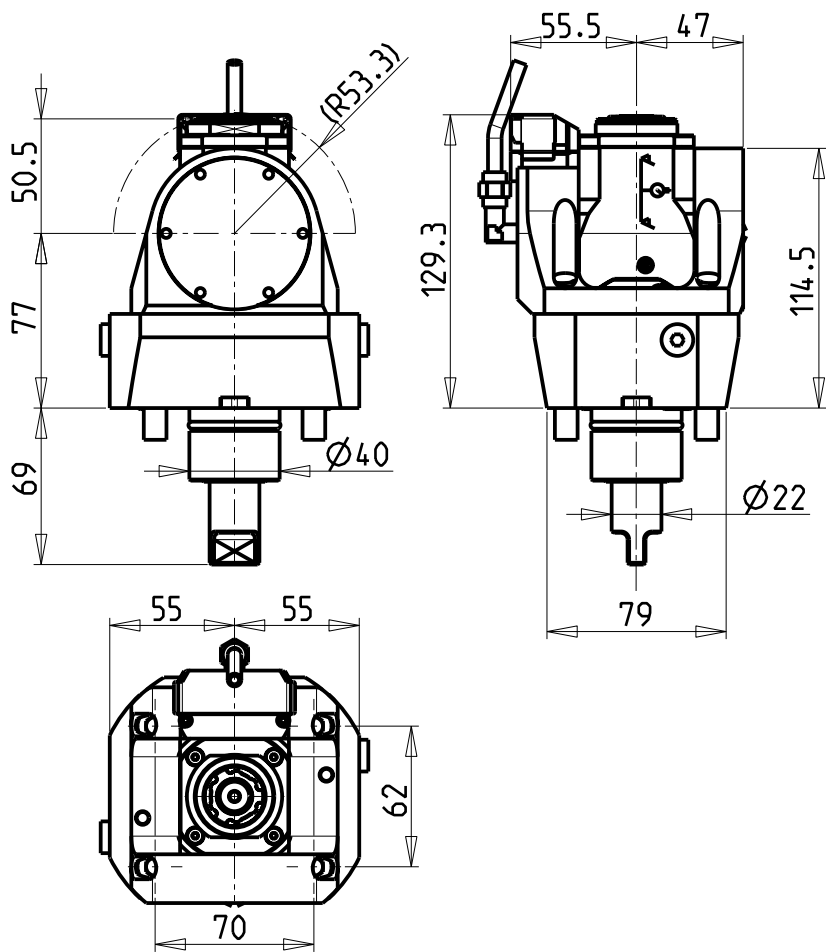

ATTENZIONE - ATTENTION - ACHTUNG

- VERIFICARE LE MISURE DI INGOMBRO PER POSSIBILE INTERFERENZA SU ALCUNI MODELLI DI MACCHINE
- Please check the overall sizes for possible interferences on some machine models
- Bitte überprüfen sie das ausmass um mögliche interferenzen auf einigen maschinen modellen zu vermeiden

ATTENZIONE - ATTENTION - ACHTUNG

- Per lo smontaggio degli utensili utilizzare sempre la chiave di contrasto come indicato nel manuale d'uso.
- For disassembly of the tools use always the contrast key as mentioned in the user instructions.
- Fuer das Abmontieren der Werkzeuge immer den Gegenschlüssel benutzen wie in der Bedienungsanleitung erwaeht.

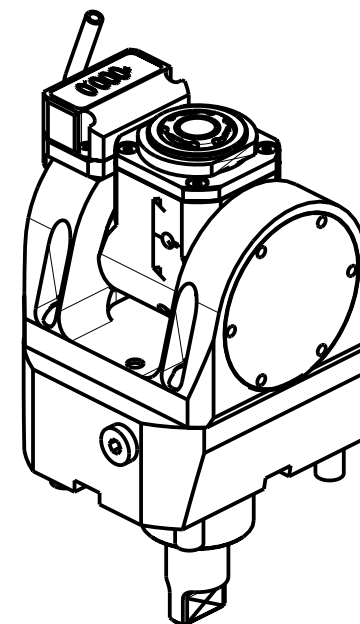
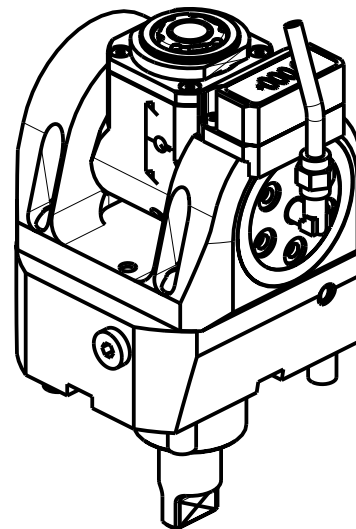

Cod. MT	Mandrino Spindle Spindel	I	RPM	Coppia Max Max Torque Max Drehmoment	Lubrificazione int. Coolant through Innenkuehlung	Lubrificazione est. Ext. coolant Aussenkuehlung	CHIAVI INCLUSE Keys included Schlüssel inbegriffen			
MNZ0586120	ER A 20	1:1	12000	30Nm	-	X	CHUB36	CHUB22	CHESL08	CHTAER20ZC
MNZ0586220	ER A 20	1:1	12000	30Nm	P=70bar	X	CHUB36	CHUB22	CHESL08	CHTAER20ZC

DMG-MORI

NZ1500/2000 - NZX1500/2000 - NL1500/2000/2500 20 STAZ. - NLX1500/2000/2500 20 STAZ.
NTX1000/2000 - NTX1000/2000/2500/3000 2ND GEN. 12ST. - NRX2000

MODULO MOTORIZZATO ORIENTABILE +/-90° 12000 RPM CON NONIO DIGITALE H=77mm
+/-90° adjustable angle driven tool 12000 rpm with digital display H=77mm

Angetriebenes Werkzeug schwenkbar +/-90° 12000 rpm mit digital display H=77mm

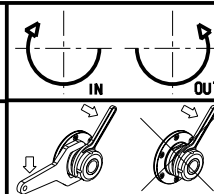

M.T. srl

Via Casino Albini 480
Tel. 0541/956034-957884
Fax 0541/956341
47842 S. GIOVANNI IN M. (RN)
e-mail: mtma@mtmarchetti.com
http://www.mtmarchetti.com

PRODUZIONE MODULI ROTANTI



PAGINA MNZ335-1-13

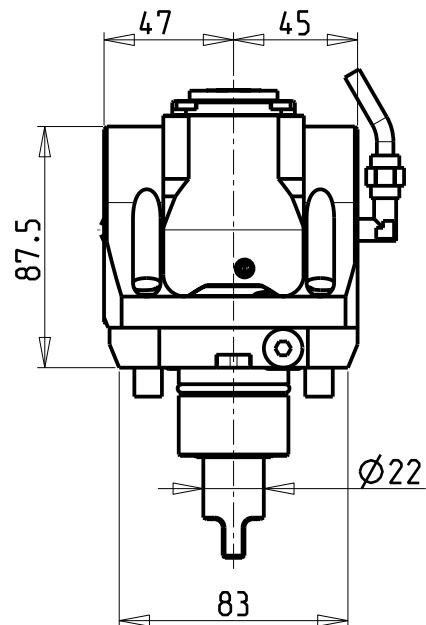
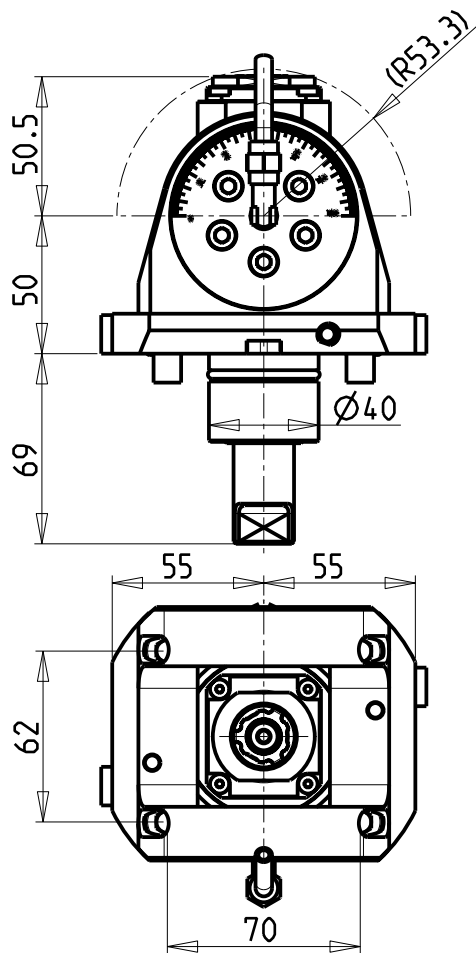

ATTENZIONE - ATTENTION - ACHTUNG

- Per lo smontaggio degli utensili utilizzare sempre la chiave di contrasto come indicato nel manuale d'uso.
- For disassembly of the tools use always the contrast key as mentioned in the user instructions.
- Fuer das Abmontieren der Werkzeuge immer den Gegenschlüssel benutzen wie in der Bedienungsanleitung erwäehnt.

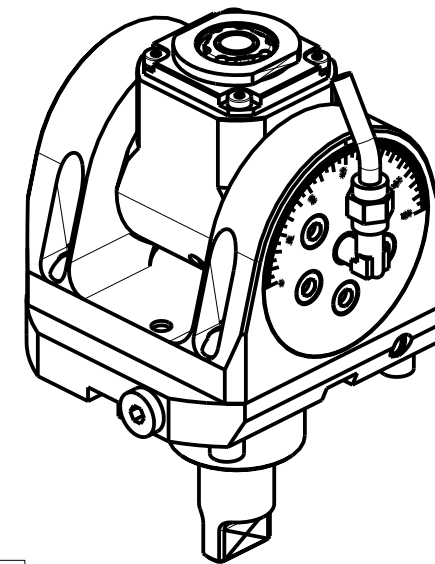

Cod. MT	Mandrino Spindle Spindel	I	RPM	Coppia Max Max Torque Max Drehmoment	Lubrificazione int. Coolant through Innenkuehlung	Lubrificazione est. Ext. coolant Aussenkuehlung	CHIAVI INCLUSE Keys included Schluessel inbegriffen			
							C HUB19_SP3	C HUB32	C HTAER16ZC	C HESL08
MNZ0390316	ERA16	1:2	12000	8Nm		X	C HUB19_SP3	C HUB32	C HTAER16ZC	C HESL08
MNZ0390416	ERA16	1:2	12000	8Nm	P=70bar	X	C HUB19_SP3	C HUB32	C HTAER16ZC	C HESL08

DMG-MORI

NZ1500/2000 - NZX1500/2000 - NT3000 SERIE - NT1000/2000 - NTX1000/2000 - NTX1000/2000/2500/3000 2ND GEN. 12ST.
DURATURN 2050MC/2550MC - NRX2000 - ALX1500/2000/2500

MODULO MOTORIZZATO ORIENTABILE +/-90° MOLTIPLICATO I=1:2 H=50mm
+/-90° adjustable angle driven tool geared-up I=1:2 H=50mm

Angetriebenes Werkzeug schwenkbar +/-90° uebersetzt I=1:2 H=50mm

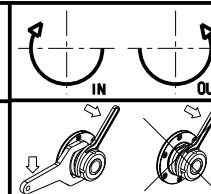

M.T. srl

Via Casino Albini 480
Tel. 0541/956034-957884
Fax 0541/956341
47842 S. GIOVANNI IN M. (RN)
e-mail: mtma@mtmarchetti.com
http://www.mtmarchetti.com

PRODUZIONE MODULI ROTANTI



PAGINA MNZ336-1-00

Subject to change without notice.

10/2018

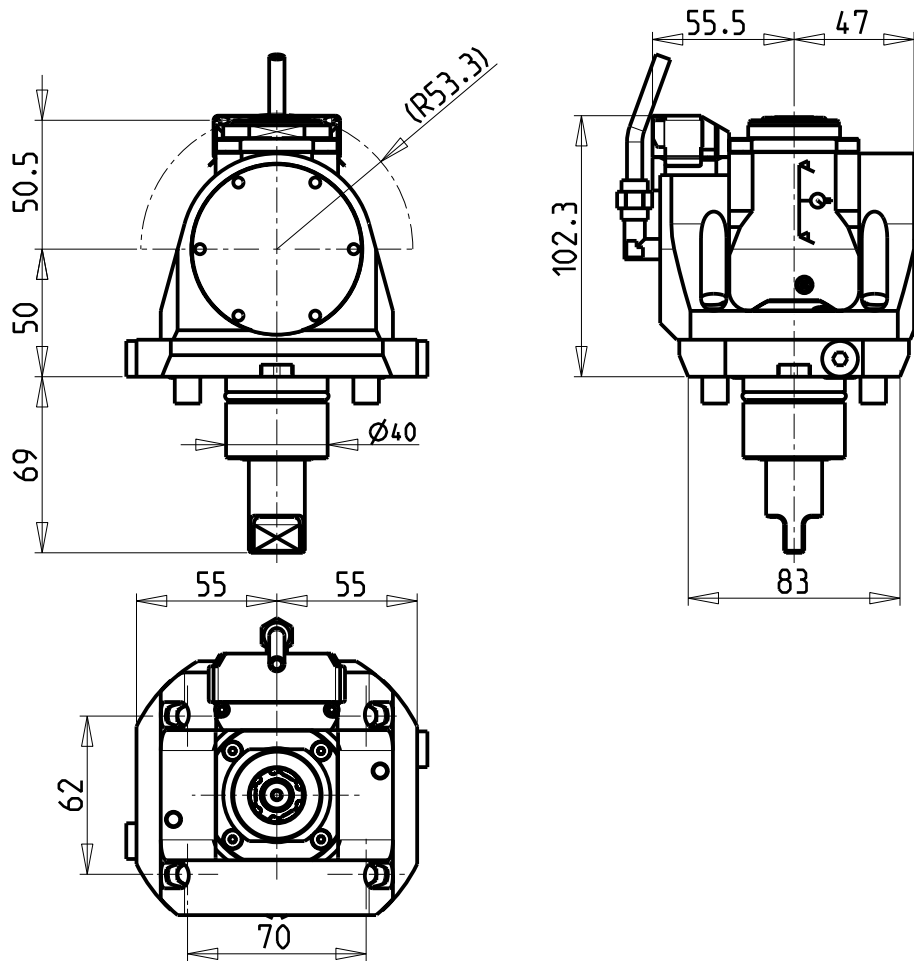

ATTENZIONE - ATTENTION - ACHTUNG

- Per lo smontaggio degli utensili utilizzare sempre la chiave di contrasto come indicato nel manuale d'uso.
- For disassembly of the tools use always the contrast key as mentioned in the user instructions.
- Fuer das Abmontieren der Werkzeuge immer den Gegenschlüssel benutzen wie in der Bedienungsanleitung erwaeht.

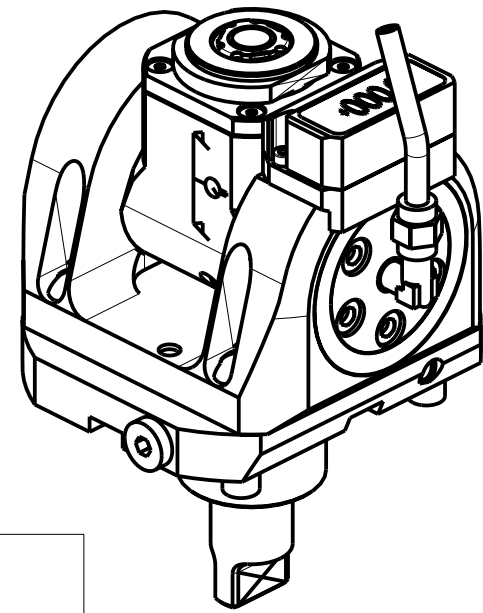

Cod. MT	Mandrino Spindle Spindel	I	RPM	Coppia Max Max Torque Max Drehmoment	Lubrificazione int. Coolant through Innenkuehlung	Lubrificazione est. Ext. coolant Aussenkuehlung	CHIAVI INCLUSE Keys included Schluessel inbegriffen			
							C HUB19_SP3	C HUB32	C HTAER16ZC	C HESL08
MNZ0395316	ERA16	1:2	12000	8Nm	-	X	C HUB19_SP3	C HUB32	C HTAER16ZC	C HESL08
MNZ0395416	ERA16	1:2	12000	8Nm	P=70bar	X	C HUB19_SP3	C HUB32	C HTAER16ZC	C HESL08

DMG-MORI
 NZ1500/2000 - NZX1500/2000 - NT3000 SERIE - NT1000/2000 - NTX1000/2000 - NTX1000/2000/2500/3000 2ND GEN. 12ST.
 DURATURN 2050MC/2550MC - NRX2000 - ALX1500/2000/2500

MODULO MOTORIZZATO ORIENTABILE +/-90° MOLTIPLICATO I=1:2 CON NONIO DIGITALE H=50mm
 +/-90° adjustable angle driven tool geared-up I=1:2 with digital display H=50mm
 Angetriebenes Werkzeug schwenkbar +/-90° uebersetzt I=1:2 mit digital display H=50mm

Subject to change without notice.

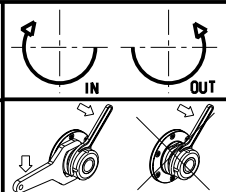

M.T. srl
 Via Casino Albini 480
 Tel. 0541/956034-957884
 Fax 0541/956341
 47842 S. GIOVANNI IN M. (RN)
 e-mail: mtma@mtmarchetti.com
 http://www.mtmarchetti.com

PRODUZIONE MODULI ROTANTI

PAGINA MNZ336-1-01

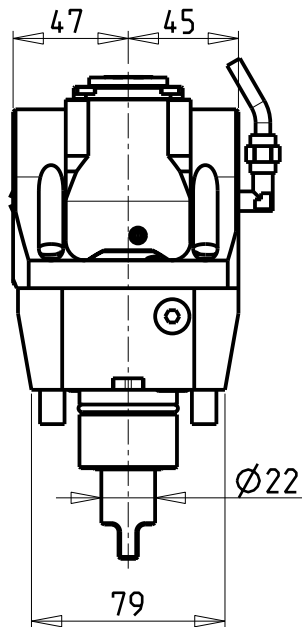
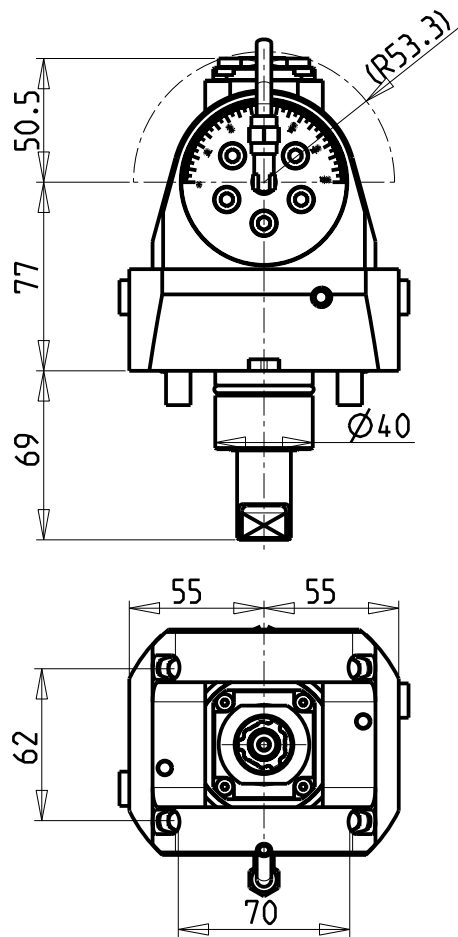

ATTENZIONE - ATTENTION - ACHTUNG

- VERIFICARE LE MISURE DI INGOMBRO PER POSSIBILE INTERFERENZA SU ALCUNI MODELLI DI MACCHINE
- Please check the overall sizes for possible interferences on some machine models
- Bitte überprüfen sie das ausmass um mögliche interferenzen auf einigen maschinen modellen zu vermeiden

ATTENZIONE - ATTENTION - ACHTUNG

- Per lo smontaggio degli utensili utilizzare sempre la chiave di contrasto come indicato nel manuale d'uso.
- For disassembly of the tools use always the contrast key as mentioned in the user instructions.
- Fuer das Abmontieren der Werkzeuge immer den Gegenschlüssel benutzen wie in der Bedienungsanleitung erwaeht.

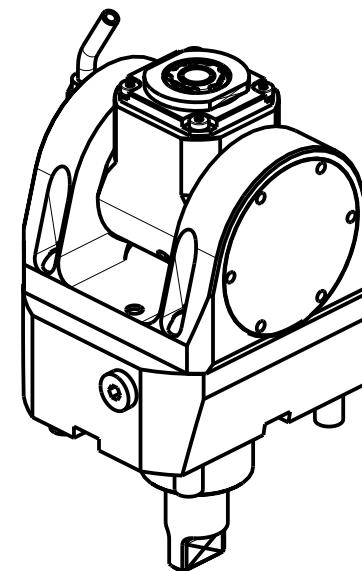
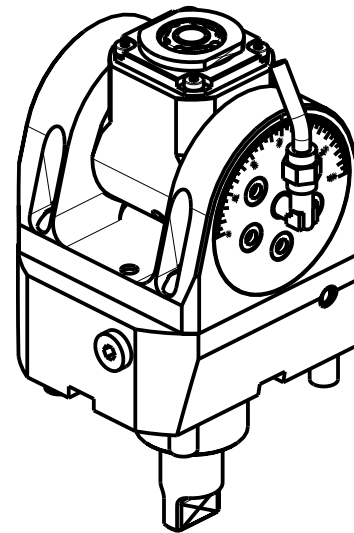

Cod. MT	Mandrino Spindle Spindel	I	RPM	Coppia Max Max Torque Max Drehmoment	Lubrificazione int. Coolant through Innenkuehlung	Lubrificazione est. Ext. coolant Aussenkuehlung	CHIAVI INCLUSE Keys included Schlüssel inbegriffen			
MNZ0391316	ERA16	1:2	12000	8Nm		X	CHUB19_SP3	CHUB32	CHTAER16ZC	CHESL08
MNZ0391416	ERA16	1:2	12000	8Nm	P=70bar	X	CHUB19_SP3	CHUB32	CHTAER16ZC	CHESL08

DMG-MORI

NZ1500/2000 - NZX1500/2000 - NT3000 SERIE - NL1500/2000/2500 20 STAZ. - NLX1500/2000/2500 20 STAZ.
 NT1000/2000 - NTX1000/2000 - NTX1000/2000/2500/3000 2ND GEN. 12ST. - DURATURN 2050MC/2550MC - NRX2000 - ALX1500/2000/2500

MODULO MOTORIZZATO ORIENTABILE +/-90° MOLTIPLICATO I=1:2 H=77mm

+/-90° adjustable angle driven tool geared-up I=1:2 H=77mm

Angetriebenes Werkzeug schwenkbar +/-90° uebersetzt I=1:2 H=77mm

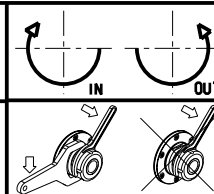

M.T. srl

Via Casino Albini 480
 Tel. 0541/956034-957884

Fax 0541/956341

47842 S. GIOVANNI IN M. (RN)

e-mail: mtma@mtmarchetti.com

http://www.mtmarchetti.com

PRODUZIONE MODULI ROTANTI



PAGINA MNZ336-1-10

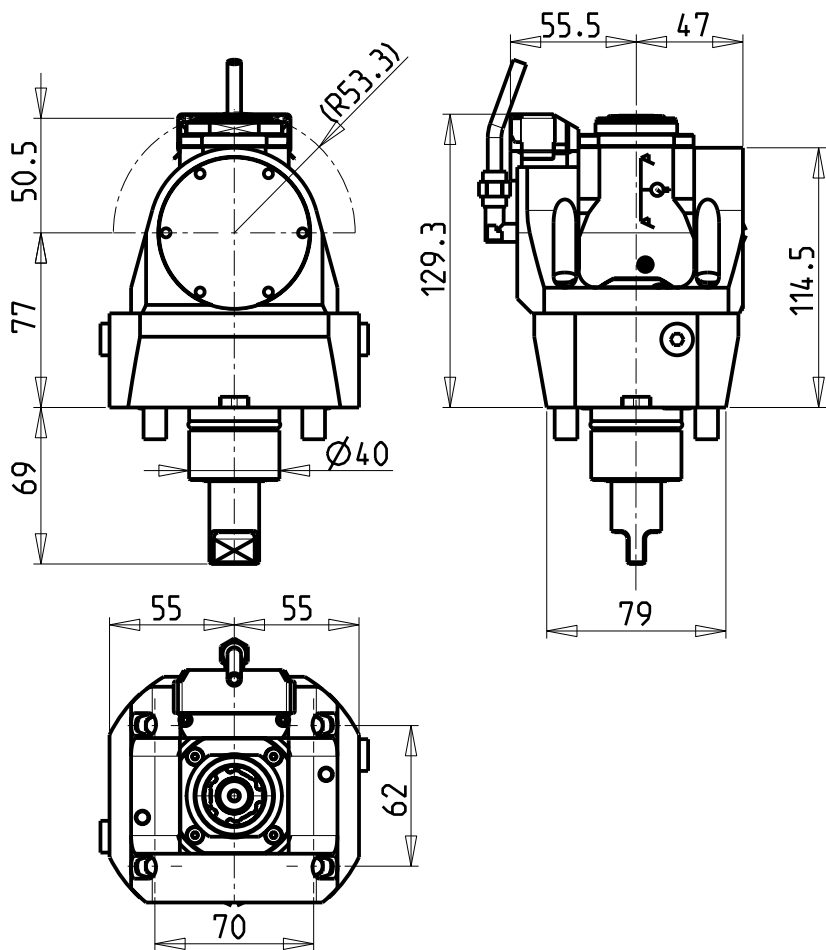

ATTENZIONE - ATTENTION - ACHTUNG

- VERIFICARE LE MISURE DI INGOMBRO PER POSSIBILE INTERFERENZA SU ALCUNI MODELLI DI MACCHINE
- Please check the overall sizes for possible interferences on some machine models
- Bitte überprüfen sie das ausmass um mögliche interferenzen auf einigen maschinen modellen zu vermeiden

ATTENZIONE - ATTENTION - ACHTUNG

- Per lo smontaggio degli utensili utilizzare sempre la chiave di contrasto come indicato nel manuale d'uso.
- For disassembly of the tools use always the contrast key as mentioned in the user instructions.
- Fuer das Abmontieren der Werkzeuge immer den Gegenschlüssel benutzen wie in der Bedienungsanleitung erwaeht.

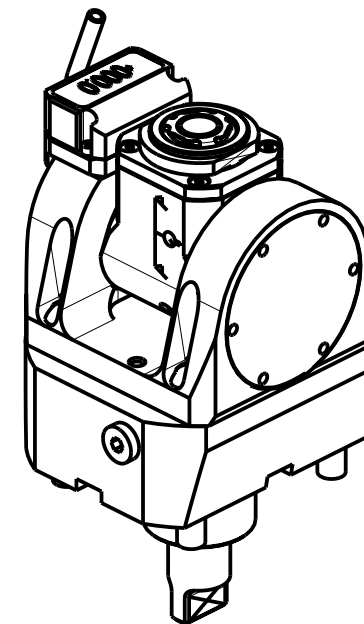
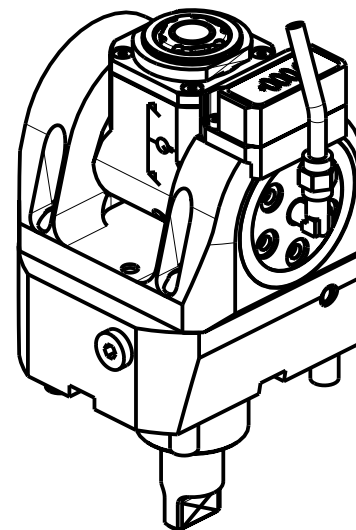

Cod. MT	Mandrino Spindle Spindel	I	RPM	Coppia Max Max Torque Max Drehmoment	Lubrificazione int. Coolant through Innenkuehlung	Lubrificazione est. Ext. coolant Aussenkuehlung	CHIAVI INCLUSE Keys included Schlüssel inbegriffen			
MNZ0396316	ERA16	1:2	12000	8Nm	-	X	CHUB19_SP3	CHUB32	CHTAER16ZC	CHESL08
MNZ0396416	ERA16	1:2	12000	8Nm	P=70bar	X	CHUB19_SP3	CHUB32	CHTAER16ZC	CHESL08

DMG-MORI

NZ1500/2000 - NZX1500/2000 - NT3000 SERIE - NL1500/2000/2500 20 STAZ. - NLX1500/2000/2500 20 STAZ.
 NT1000/2000 - NTX1000/2000 - NTX1000/2000/2500/3000 2ND GEN. 12ST. - DURATURN 2050MC/2550MC - ALX1500/2000/2500

MODULO MOTORIZZATO ORIENTABILE +/-90° MOLTIPLICATO I=1:2 CON NONIO DIGITALE H=77mm

+/-90° adjustable angle driven tool geared-up I=1:2 with digital display H=77mm

Angetriebenes Werkzeug schwenkbar +/-90° uebersetzt I=1:2 mit digital display H=77mm

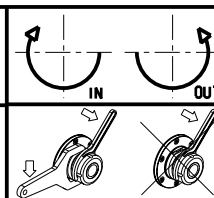

M.T. srl

Via Casino Albini 480
 Tel. 0541/956034-957884
 Fax 0541/956341

47842 S. GIOVANNI IN M. (RN)
 e-mail: mtma@mtmarchetti.com
 http://www.mtmarchetti.com

PRODUZIONE MODULI ROTANTI



PAGINA MNZ336-1-11

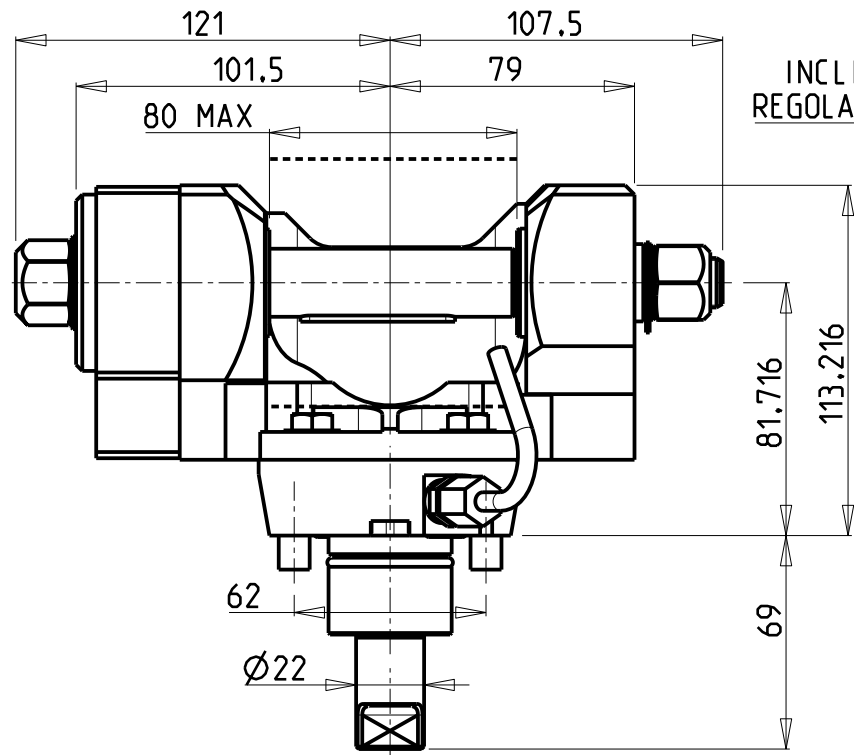
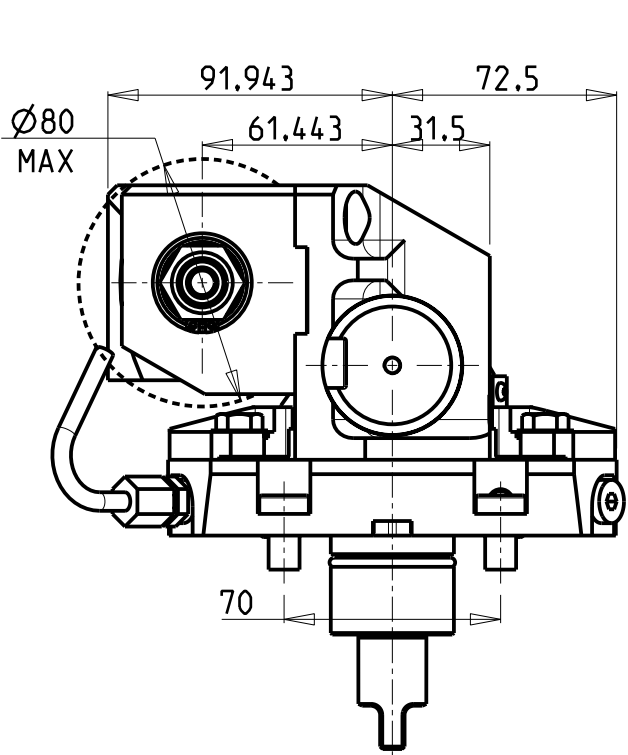

INCLINAZIONE
REGOLABILE ±20°

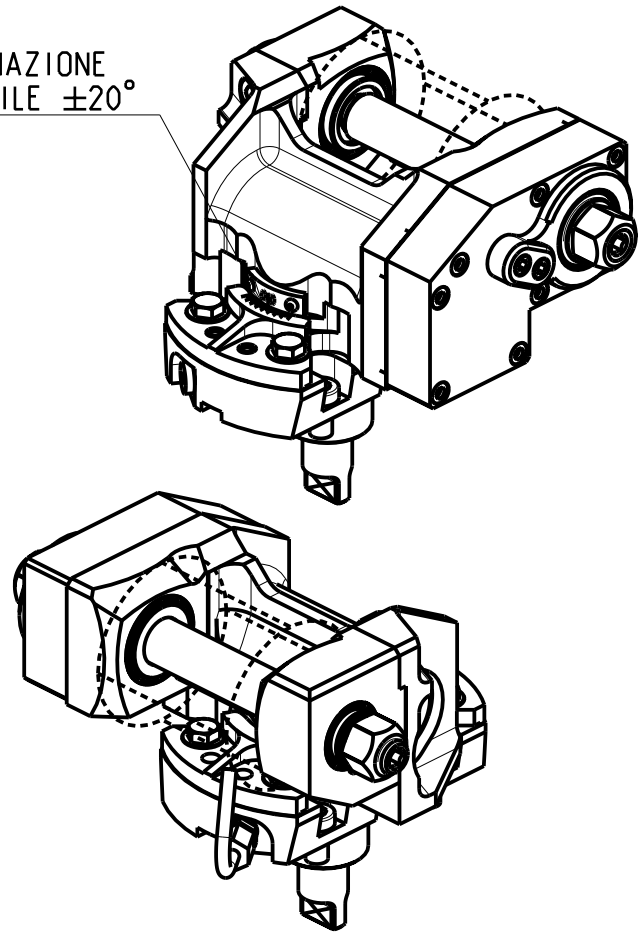

DOTAZIONI - SUPPLIED WITH - AUSSTATTUNG

- N°1 ALBERO + DISTANZIALI
- N°1 SHAFT + SPACER
- N°1 DORN + ABSTANDSSTUECK

PER ALBERI E DISTANZIALI VEDI PAG. TBL250-1-00
FOR SHAFT END SPACER SEE PAGE TBL250-1-00
FUER DORN UND ABSTANDSSTUECK SEITE TBL250-1-00

Cod. MT	I	RPM max	Coppia Max Max Torque Max Drehmoment	Reversibile lato mandrino/contromandrino Reversible sub/main spindle side Umkehrbare Spindel-seite/ Gegenspindel-seite	Lubrificazione est. Ext. coolant Aussenkuehlung	D (mm)	D (Inch)	CHIAVI INCLUSE Keys included Schluessel inbegriffen			
MNZ0201100	1:1	6000	60Nm	X	X	16-22-27-32	3/4"-1"-1 1/4"	CHUB24	CHUB13	CHESL08	CHESL07
MNZ0202100	2:1	3000	80Nm	X	X	16-22-27-32	3/4"-1"-1 1/4"	CHUB24	CHUB13	CHESL08	CHESL07

DMG-MORI

NZ1500/2000 - NZX1500/2000 - NT3000 SERIE - NL1500/2000/2500 20 STAZ. - NLX1500/2000/2500 20 STAZ.
NT1000/2000 - NTX1000/2000 - NTX1000/2000/2500/3000 2ND GEN. 12ST. - DURATURN 2050MC/2550MC - ALX1500/2000/2500

MODULO MOTORIZZATO PORTACREATORE

Driven gear hobber
Angetriebenes Zahnradwaeltzraes-Werkzeug

Subject to change without notice.

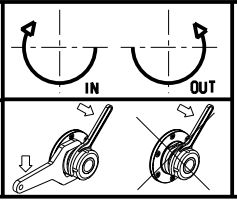

M.T. srl

Via Casino Albini 480
Tel. 0541/956034-957884
Fax 0541/956341
47842 S. GIOVANNI IN M. (RN)
e-mail: mtma@tmarchetti.com
http://www.tmmarchetti.com

PRODUZIONE MODULI ROTANTI



PAGINA MNZ340-1-00

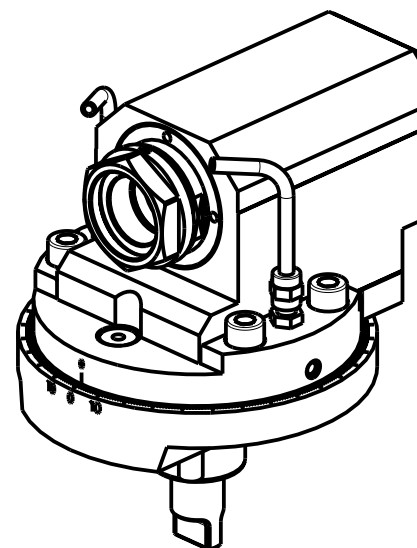
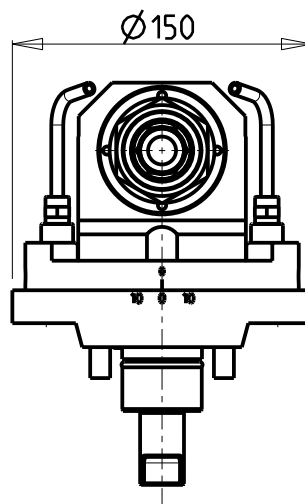
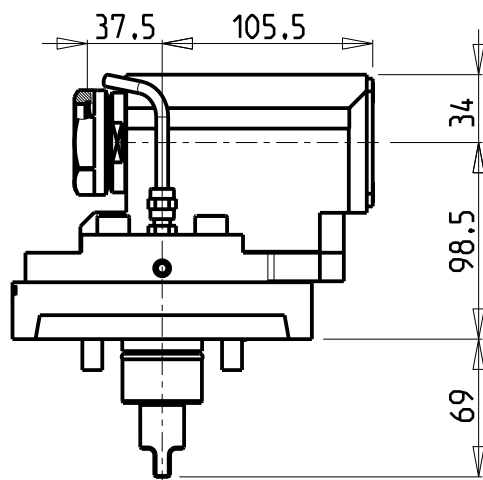
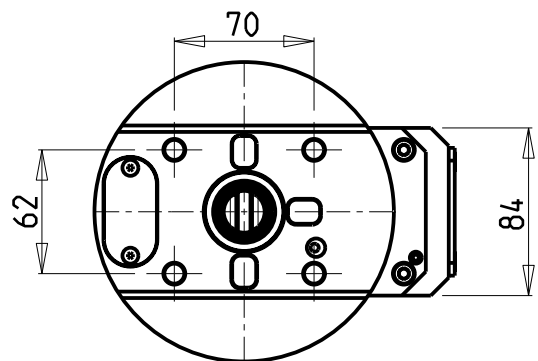

ATTENZIONE - ATTENTION - ACHTUNG

- VERIFICARE LE MISURE DI INGOMBRO PER POSSIBILE INTERFERENZA SU ALCUNI MODELLI DI MACCHINE
- Please check the overall sizes for possible interferences on some machine models
- Bitte überprüfen sie das ausmass um mögliche interferenzen auf einigen maschinen modellen zu vermeiden

PER PORTAUTENSILI MODULARI MTSK-40 VEDI PAG. TBL300-1-40
 FOR MTSK-40 QUICK CHANGE TOOLHOLDERS CLAMPINGS SEE PAGE TBL300-1-40
 FUER MTSK-40 MODULARE WERKZEUGAUFNAHMEN SIEHE SEITE TBL300-1-40

Cod. MT	Mandrino Spindle Spindel	I	RPM	Coppia Max Max Torque Max Drehmoment	Lubr.esterna Ext. coolant Aussenkuehlung	CHIAVI INCLUSE Keys included Schluessel einbegriffen
MNZ0550100	MTSK-40	1:1	6000	50Nm	X	n°2 CHUB46

DMG-MORI

NZ1500/2000 - NZX1500/2000 - NL1500/2000/2500 20 STAZ. - NLX1500/2000/2500 20 STAZ. - ALX1500/2000/2500

MODULO MOTORIZZATO ASSIALE MTSK PER POWER SKIVING H=98.5mm

Axial MTSK driven tool for Power Skiving H=98.5mm

Axial MTSK angetriebenes Werkzeug fuer Power Skiving H=98.5mm

Subject to change without notice.

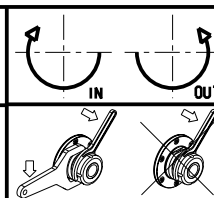

M.T. srl

Via Casino Albini 480
 Tel. 0541/956034-957884
 Fax 0541/956341

47842 S. GIOVANNI IN M. (RN)
 e-mail: mtma@mtmarchetti.com
 http://www.mtmarchetti.com

PRODUZIONE MODULI ROTANTI



PAGINA MNZ350-1-00-K

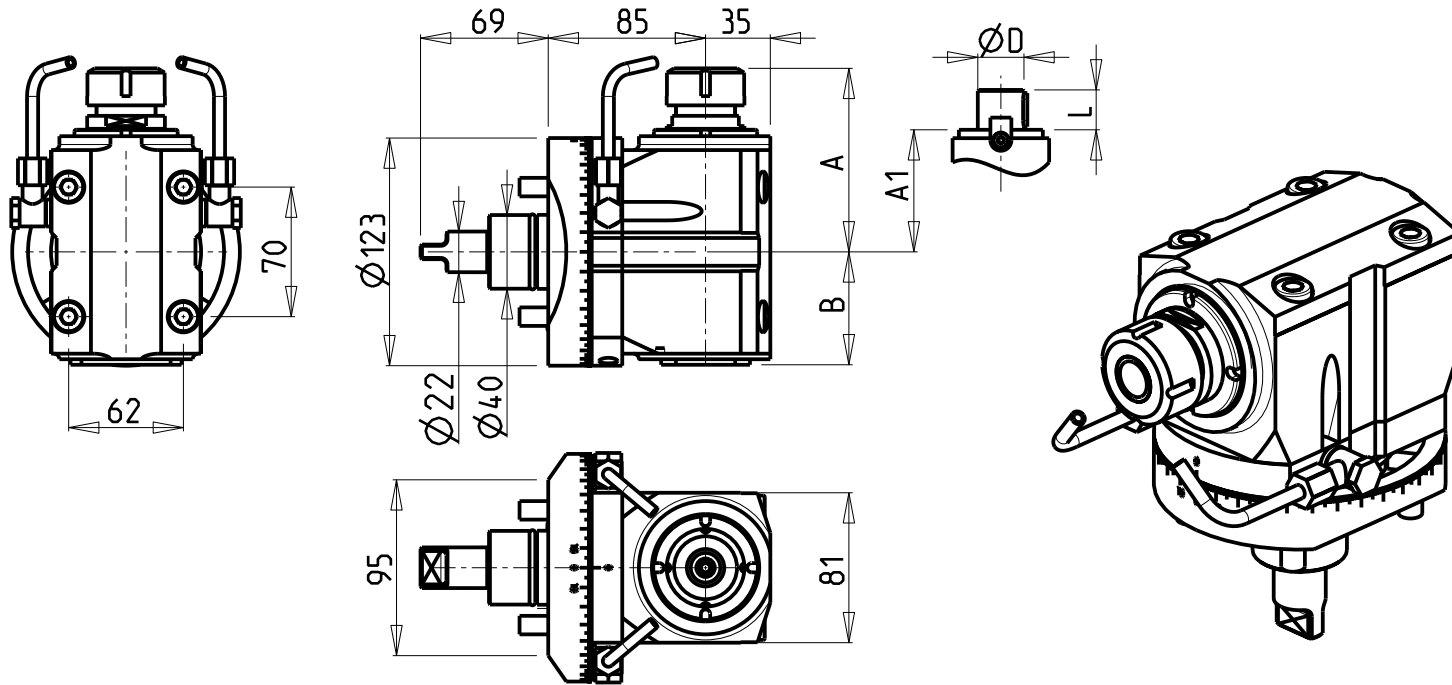

ATTENZIONE - ATTENTION - ACHTUNG

- Per lo smontaggio degli utensili utilizzare sempre la chiave di contrasto come indicato nel manuale d'uso.
- For disassembly of the tools use always the contrast key as mentioned in the user instructions.
- Fuer das Abmontieren der Werkzeuge immer den Gegenschlüssel benutzen wie in der Bedienungsanleitung erwäehnt.

- Chiave inclusa
- Key included
- Schlüssel inbegriffen

Cod. MT	Mandrino Spindle Spindel	I	RPM	Coppia Max Max Torque Max Drehmoment	Reversibile lato mandrino/contromandrino Reversible sub/main spindle side Umkehrbare Spindel-seite/ Gegenspindel-seite	Lubr.interna Coolant through Innenkuehlung	Lubr.esterna Ext. coolant Aussenkuehlung	A	A1	B	D	L	CHIAVI NON INCLUDE Keys not included Schluessel nicht einbegriffen	
													CHUB36	CHSTER20
MNZ0350120	ER20	1:1	6000	40Nm	X		X	98.16	-	61	-	-	CHUB36	CHSTER20
MNZ0350125	ER25	1:1	6000	40Nm	X		X	99.16	-	61	-	-	CHUB36	CHSTER25
MNZ0350132	ER32	1:1	6000	40Nm	X		X	102.16	-	61	-	-	CHUB36	CHSTER32
MNZ0350225	ER25	1:1	6000	40Nm	X	P=70bar	X	99.16	-	71	-	-	CHUB36	CHSTER25
MNZ0350232	ER32	1:1	6000	40Nm	X	P=70bar	X	102.76	-	71	-	-	CHUB36	CHSTER32
MNZ0351617	Ø16x17	1:1	6000	40Nm	X		X	-	76.5	61	16	17	CHUB36	CH_VTCROCE_M08 *
MNZ0352219	Ø22x19	1:1	6000	40Nm	X		X	-	78.5	61	22	19	CHUB36	CH_VTCROCE_M10 *
MNZ0352721	Ø27x21	1:1	6000	40Nm	X		X	-	79.5	61	27	21	CHUB36	CH_VTCROCE_M12 *
MNZ0351919	Ø3/4"x3/4"	1:1	6000	40Nm	X		X	-	77	61	3/4"	3/4"	CHUB36	CH_VTCROCE_M08 *

DMG-MORI

NZ1500/2000 - NZX1500/2000 - NT3000 SERIE - NL1500/2000/2500 20 STAZ. - NLX1500/2000/2500 20 STAZ.
 NT1000/2000 - NTX1000/2000 - NTX1000/2000/2500/3000 2ND GEN. 12ST. - DURATURN 2050MC/2550MC - ALX1500/2000/2500

MODULO MOTORIZZATO ASSIALE ANGOLARE ±180°
 Axial adjustable angle ±180° driven tool
 Axial angetriebenes Werkzeug schwenkbar ±180°

Subject to change without notice.

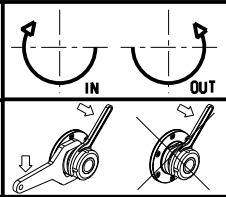

M.T. srl

Via Casino Albini 480
 Tel. 0541/956034-957884
 Fax 0541/956341
 47842 S. GIOVANNI IN M. (RN)
 e-mail: mtma@mtmarchetti.com
 http://www.mtmarchetti.com

PRODUZIONE MODULI ROTANTI



PAGINA MNZ355-1-00

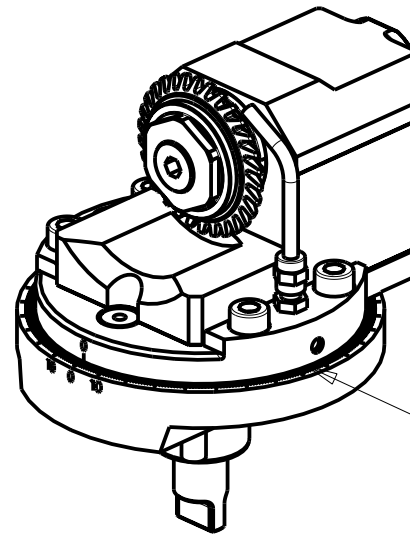
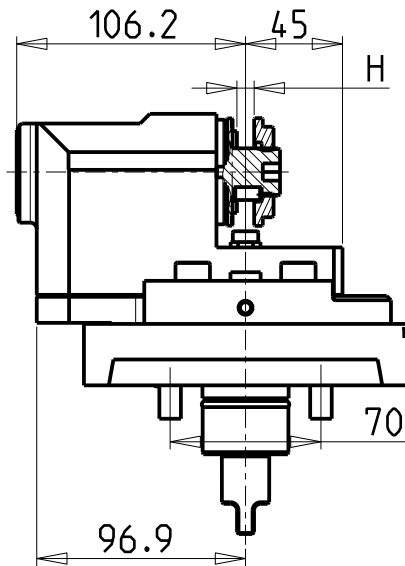
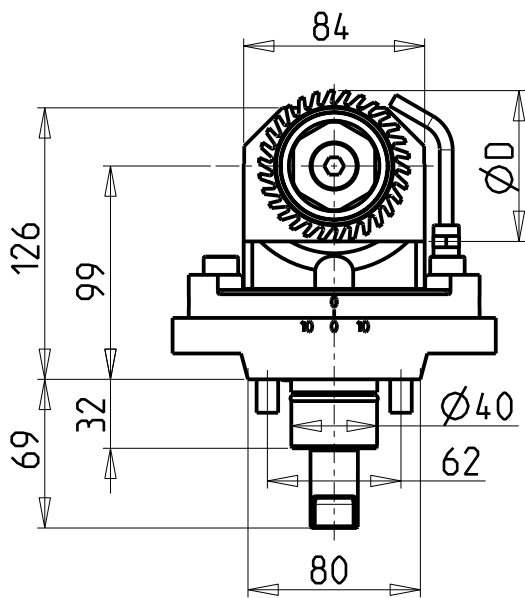

POSSIBILITA' DI
ROTAZIONE 360°

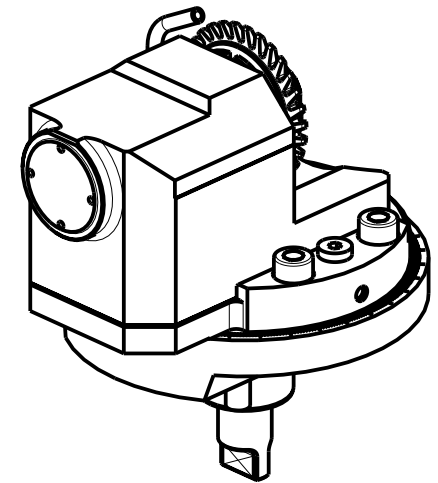
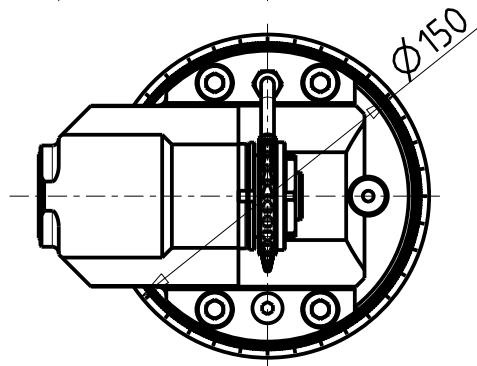

Cod. MT	Mandrino Spindle Spindel	I	RPM	Coppia Max Max Torque Max Drehmoment	Lubrificazione est. Ext. coolant Aussehenkuehlung	ØD	H	CHIAVI INCLUSE Keys included Schluessel einbegriffen		
MNZ0438022	Ø22x12	1:1	6000	50Nm	X	63-70-80	MAX 12	CHUB38	CHESL07	CHESL08
MNZ0438125	Ø1"x12	1:1	6000	50Nm	X	63-70-80	MAX 12	CHUB38	CHESL07	CHESL08

DMG-MORI

NZ1500/2000 - NZX1500/2000 - NT3000 SERIE - NL1500/2000/2500 20 STAZ. - NLX1500/2000/2500 20 STAZ.
NT1000/2000 - NTX1000/2000 - NTX1000/2000/2500/3000 2ND GEN. 12ST. - DURATURN 2050MC/2550MC - ALX1500/2000/2500

MODULO MOTORIZZATO PER VITI SENZA FINE

Driven tool for worm screws

Angetriebenes Werkzeug fuer schrauben ohne ende

Subject to change without notice.

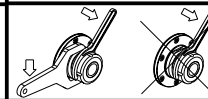
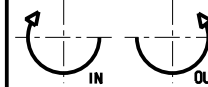

M.T. srl

Via Casino Albini 480
Tel. 0541/956034-957884
Fax 0541/956341
47842 S. GIOVANNI IN M. (RN)
e-mail: mtma@mtmarchetti.com
http://www.mtmarchetti.com

PRODUZIONE MODULI ROTANTI



PAGINA MNZ359-1-00

10/2018

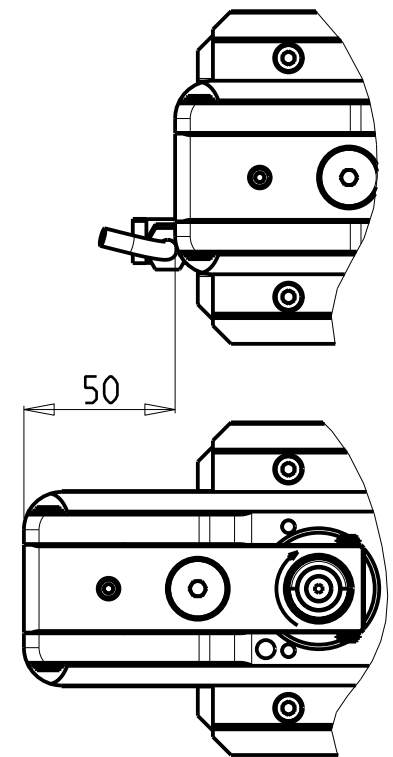
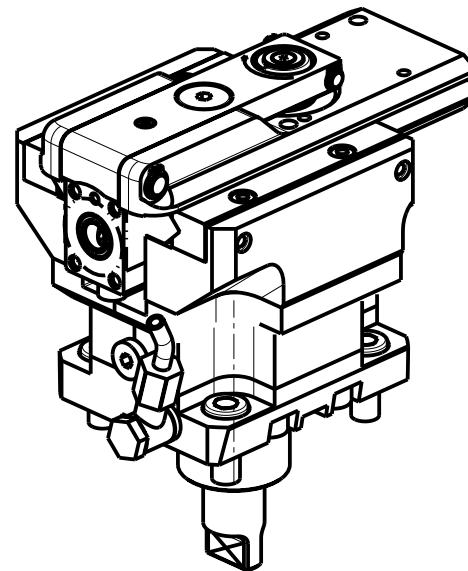
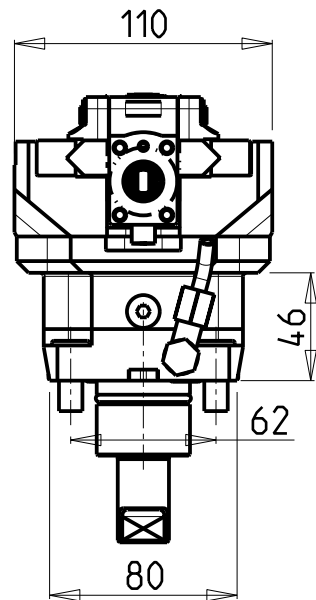
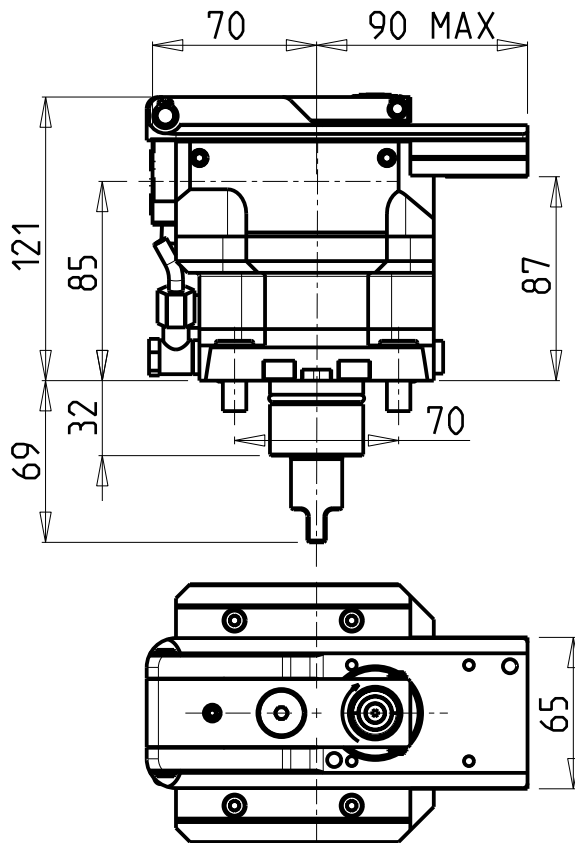

PER UTENSILI STOZZATORI VEDI PAG. TBL400-1-00
 FOR DRIVEN SLOTTING TOOL CUTTING-TOOLS SEE PAGE TBL400-1-00
 FÜR NUTENSTOSS-WERKZEUG SCHNEIDWERKZEUGE SIEHE SEITE TBL400-1-00

Cod. MT	I	RPM MAX	Reversibile lato mandrino/contromandrino Reversible sub/main spindle side Umkehrbare Spindel-seite/ Gegenspindel-seite	Lubr. esterna Ext. coolant Aussenkuehlung
MNZ0420100	4:1	2000	X	X

DMG-MORI

NZ1500/2000 - NZX1500/2000 - NT3000 SERIE - NL1500/2000/2500 20 STAZ. - NLX1500/2000/2500 20 STAZ.
 NTX1000/2000/2500/3000 2ND GEN. 12ST. - DURATURN 2050MC/2550MC - NRX2000 - ALX1500/2000/2500

MODULO MOTORIZZATO STOZZATORE CORSA 50mm H=85mm

Slotting driven tool 50mm stroke H=85mm

Keilnutenstossmaschine 50mm Hub H=85mm

Subject to change without notice.

M.T. srl

Via Casino Albini 480
 Tel. 0541/956034-957884
 Fax 0541/956341
 47842 S. GIOVANNI IN M. (RN)
 e-mail: mtma@mtmarchetti.com
 http://www.mtmarchetti.com

PRODUZIONE MODULI ROTANTI



PAGINA MNZ360-1-00

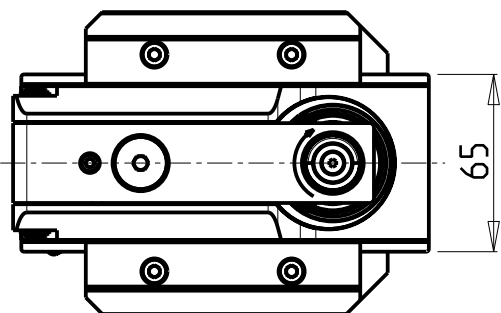
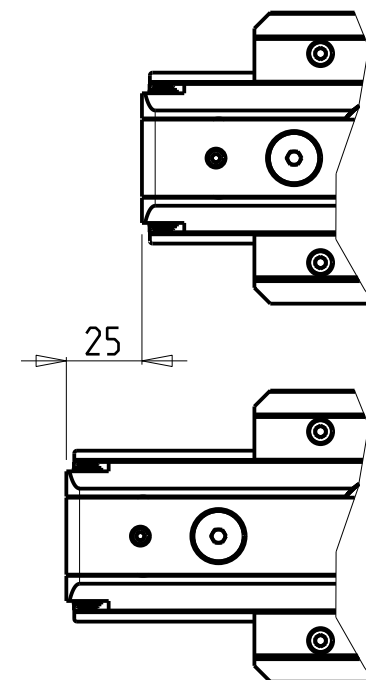
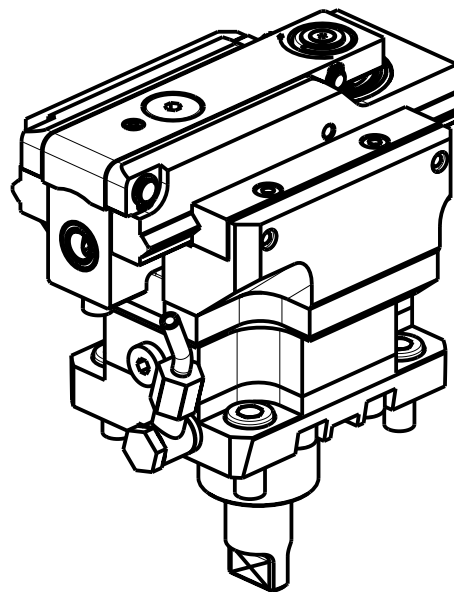
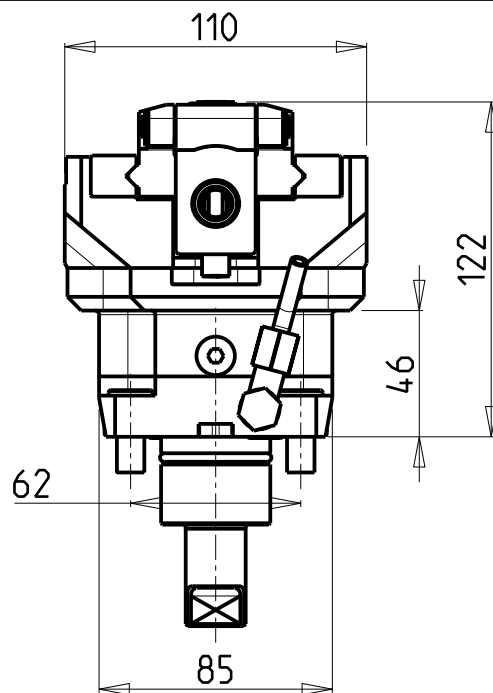
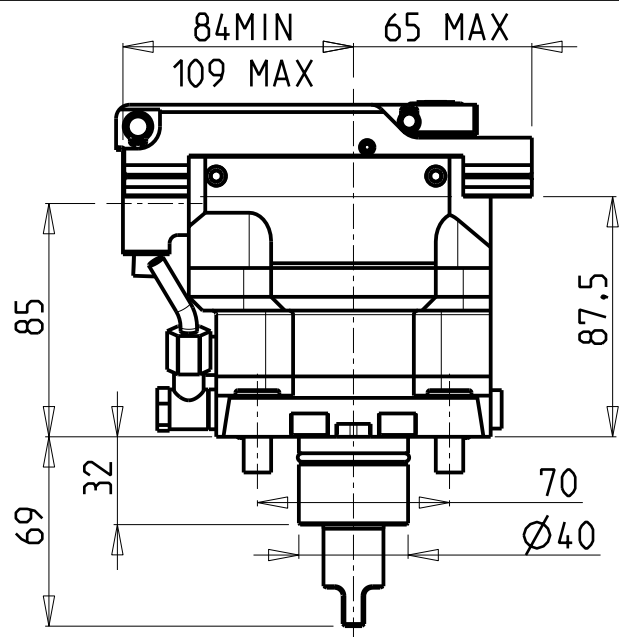

PER UTENSILI STOZZATORI VEDI PAG. TBL400-1-00
 FOR DRIVEN SLOTTING TOOL CUTTING-TOOLS SEE PAGE TBL400-1-00
 FÜR NUTENSTOSS-WERKZEUG SCHNEIDWERKZEUGE SIEHE SEITE TBL400-1-00

Cod. MT	I	RPM MAX	Reversibile lato mandrino/contromandrino Reversible sub/main spindle side Umkehrbare Spindelseite/ Gegenspindelseite	Lubr. esterna Ext. coolant Aussenkuehlung
MNZ0420200	4:1	2400	X	X

DMG-MORI

NZ1500/2000 - NZX1500/2000 - NT3000 SERIE - NL1500/2000/2500 20 STAZ. - NLX1500/2000/2500 20 STAZ.
 NT1000/2000 - NTX1000/2000/2500/3000 2ND GEN. 12ST. - DURATURN 2050MC/2550MC - NRX2000 - ALX1500/2000/2500

MODULO MOTORIZZATO STOZZATORE CORSA 25mm H=85mm

Slotting driven tool 25mm stroke H=85mm

Keilnutenstossmaschine 25mm Hub H=85mm

Subject to change without notice.

M.T. srl

Via Casino Albini 480
 Tel. 0541/956034-957884
 Fax 0541/956341
 47842 S. GIOVANNI IN M. (RN)
 e-mail: mtma@mtmarchetti.com
 http://www.mtmarchetti.com

PRODUZIONE MODULI ROTANTI



PAGINA MNZ360-1-01

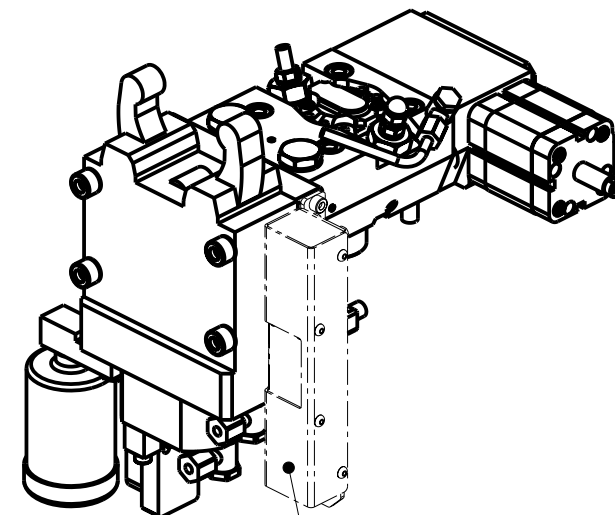
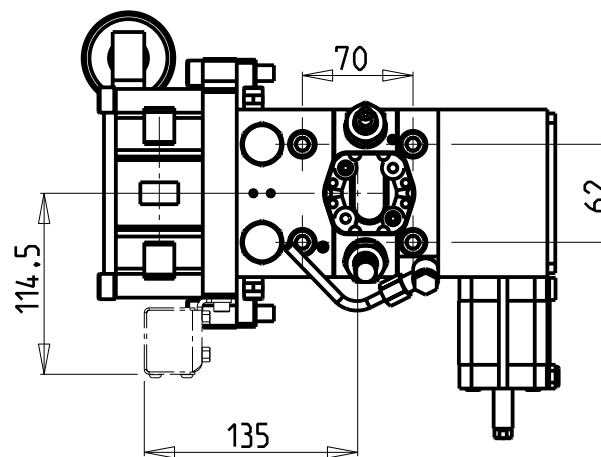
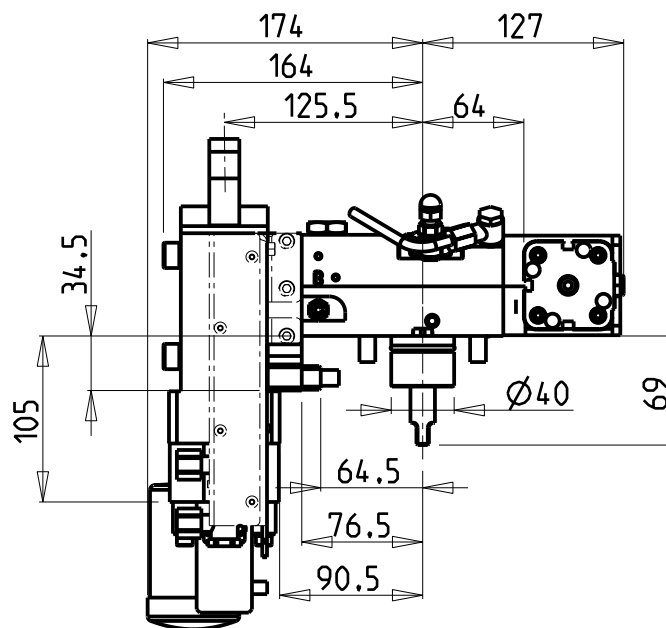
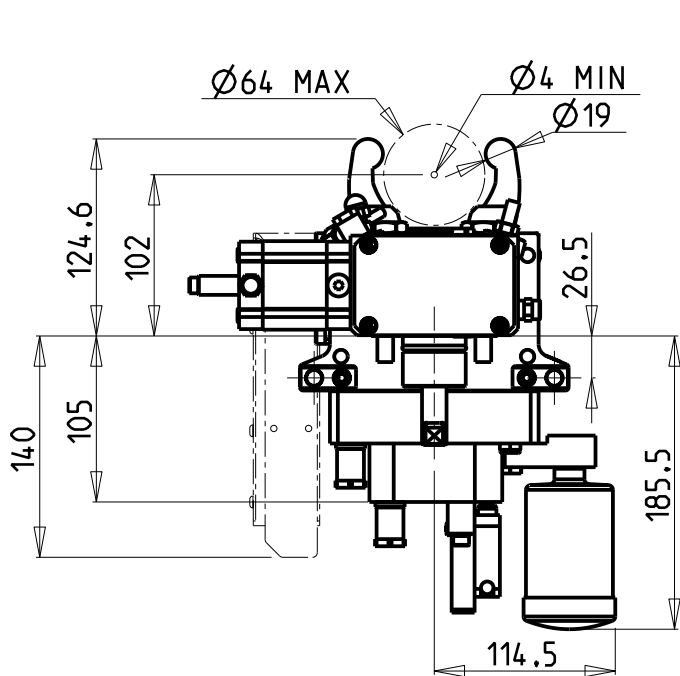

Only for
MNZ0310100JP



- # CON GESTIONE ELETTRONICA
APERTURA COMPLETA DELLA LUNETTA
- # With Electronic control of steady
rest arms complete opening
- # Mit vollstaendiger elektronischer
Oeffnungsbedienug der Luenette

Cod. MT	I	RPM	Lubr.esterna Ext. coolant Aussenkuehlung	
MNZ0310100	1:1	6000	X	
# MNZ0310100EU	1:1	6000	X	EUROPE - AFRICA - MIDDLE EAST - NORTH ASIA
# MNZ0310100US	1:1	6000	X	USA - CANADA - MEXICO - AUSTRALIA - SOUTH ASIA
# MNZ0310100JP	1:1	6000	X	JAPAN

DMG-MORI
NZ1500/2000 - NZX1500/2000

MODULO MOTORIZZATO PER LUNETTA (TAGLIA 1)
Steady rest driven tool (Size 1)
Angetriebenes Werkzeug fuer Luenette (Grosses 1)

Subject to change without notice.

M.T. srl

Via Casino Albini 480
Tel. 0541/956034-957884
Fax 0541/956341
47842 S. GIOVANNI IN M. (RN)
e-mail: mtma@mtmarchetti.com
http://www.mtmarchetti.com

PRODUZIONE MODULI ROTANTI



PAGINA MNZ361-1-00

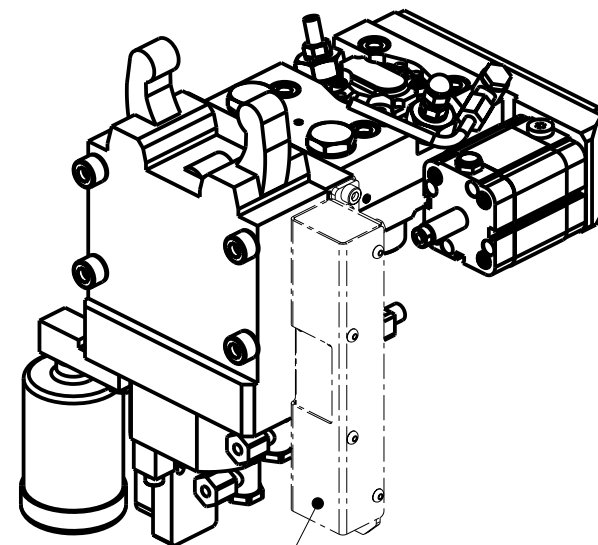
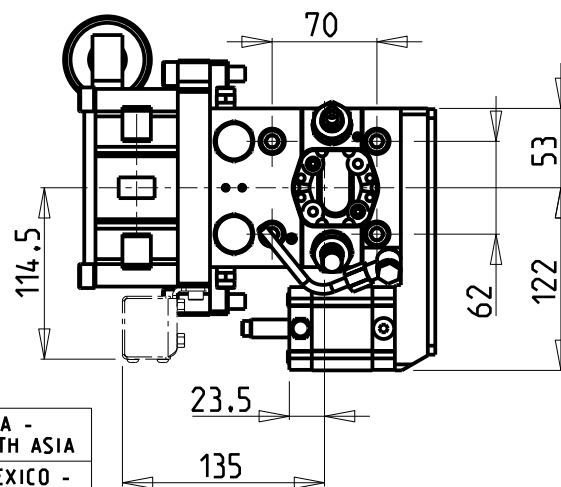
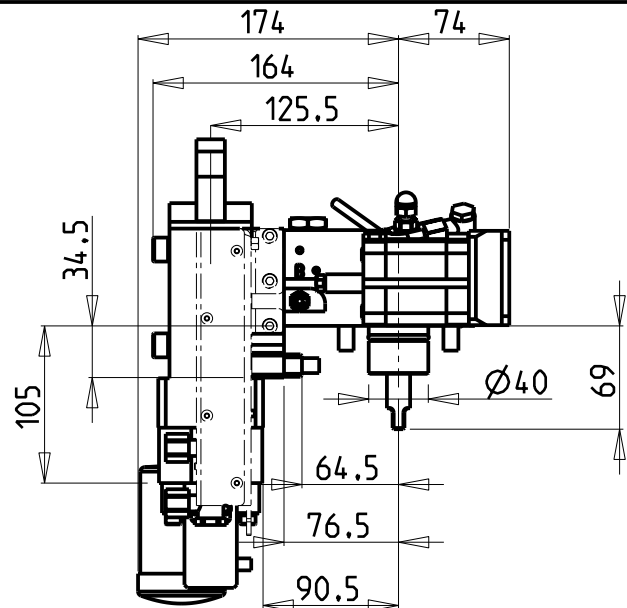
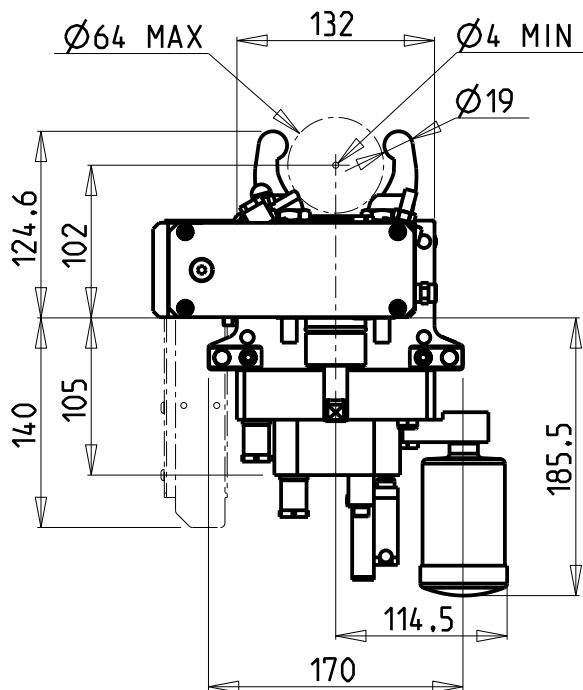

Only for
MNZ0310150JP



- # CON GESTIONE ELETTRONICA
APERTURA COMPLETA DELLA LUNETTA
- # With Electronic control of steady
rest arms complete opening
- # Mit vollständiger elektronischer
Öffnungsbedienung der Luenette

Cod. MT	I	RPM	Lubr. esterna Ext. coolant Aussenkuehlung	
MNZ0310150	1:1	6000	X	
# MNZ0310150EU	1:1	6000	X	EUROPE - AFRICA - MIDDLE EAST - NORTH ASIA
# MNZ0310150US	1:1	6000	X	USA - CANADA - MEXICO - AUSTRALIA - SOUTH ASIA
# MNZ0310150JP	1:1	6000	X	JAPAN

DMG-MORI
NZ1500/2000 - NZX1500/2000 - NT3000 SERIE - NT1000/2000 - NTX1000/2000

MODULO MOTORIZZATO PER LUNETTA (TAGLIA 1)
Steady rest driven tool (Size 1)
Angetriebenes Werkzeug fuer Luenette (Grosses 1)

Subject to change without notice.

M.T. srl

Via Casino Albini 480
Tel. 0541/956034-957884
Fax 0541/956341
47842 S. GIOVANNI IN M. (RN)
e-mail: mtma@mtmarchetti.com
http://www.mtmarchetti.com

PRODUZIONE MODULI ROTANTI



PAGINA MNZ361-1-10

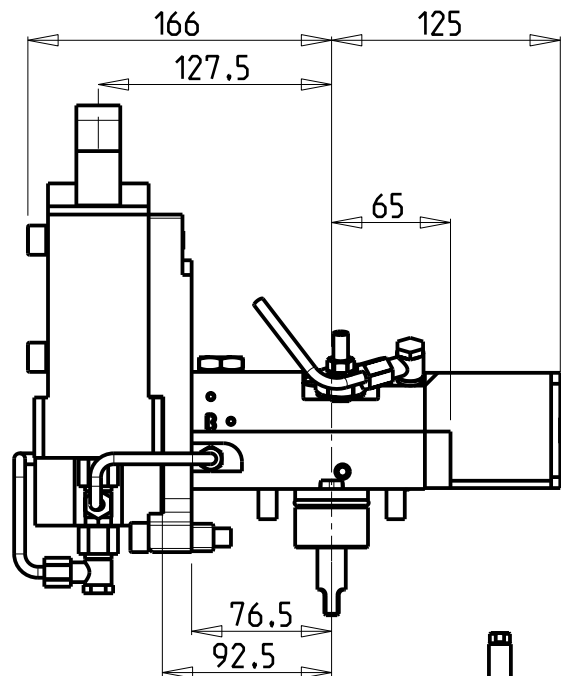
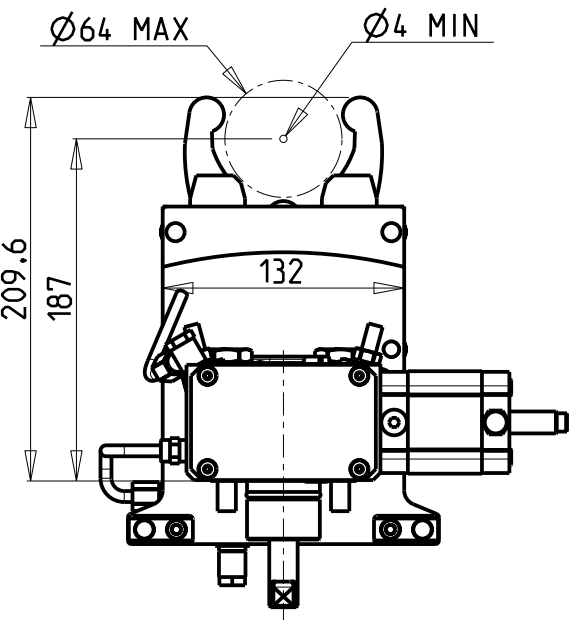

ATTENZIONE: SOLO PER TORRETTA "T2"
 WARNING: ONLY FOR "T2" TURRET
 ACHTUNG: NUR FUER REVOLVER "T2"

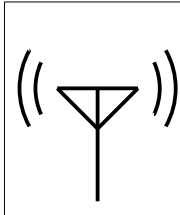
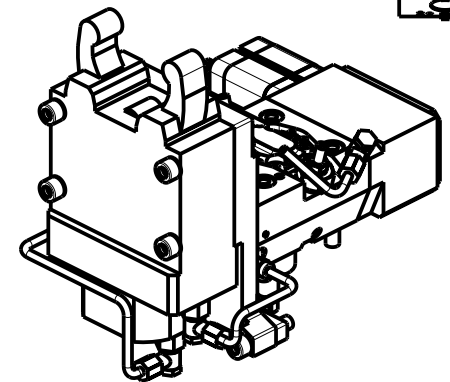
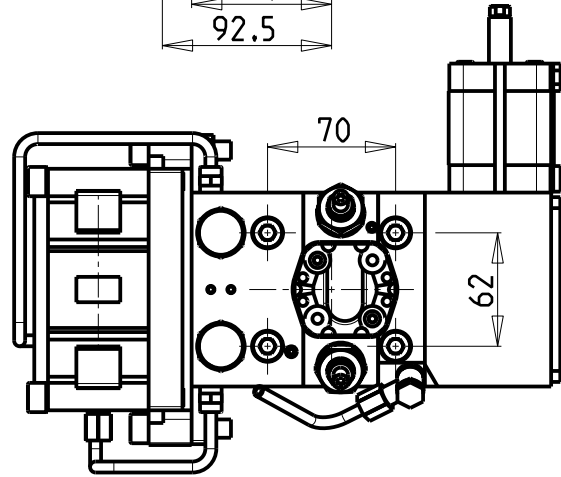
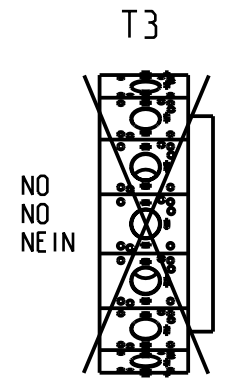
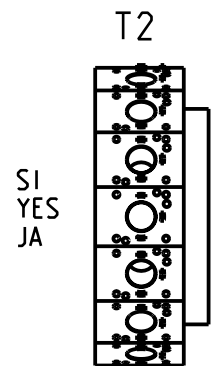
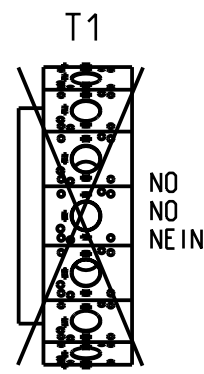

CON GESTIONE ELETTRONICA APERTURA COMPLETA DELLA LUNETTA
 # With Electronic control of steady rest arms complete opening
 # Mit vollstaendiger elektronischer Oeffnungsbedienug der Luenette

Cod. MT	I	RPM	Lubr.esterna Ext. coolant Aussenkuehlung
MNZ0310200	1:1	6000	X
# MNZ0310200EU	1:1	6000	X
# MNZ0310200US	1:1	6000	X

PER U.S.A.-AUSTRALIA-CANADA
 For U.S.A.-Australia-Canada
 Fuer U.S.A.-Australien-Kanada

DMG-MORI
 NZ1500/2000

MODULO MOTORIZZATO PER LUNETTA RIALZATA (TAGLIA 1)
 Higher version steady rest driven tool (Size 1)
 Angetriebenes werkzeug fuer Luenette, hoehere Version (Grossesse 1)

Subject to change without notice.

M.T. srl

Via Casino Albini 480
 Tel. 0541/956034-957884
 Fax 0541/956341
 47842 S. GIOVANNI IN M. (RN)
 e-mail: mtma@mtmarchetti.com
 http://www.mtmarchetti.com

PRODUZIONE MODULI ROTANTI



PAGINA MNZ362-1-00

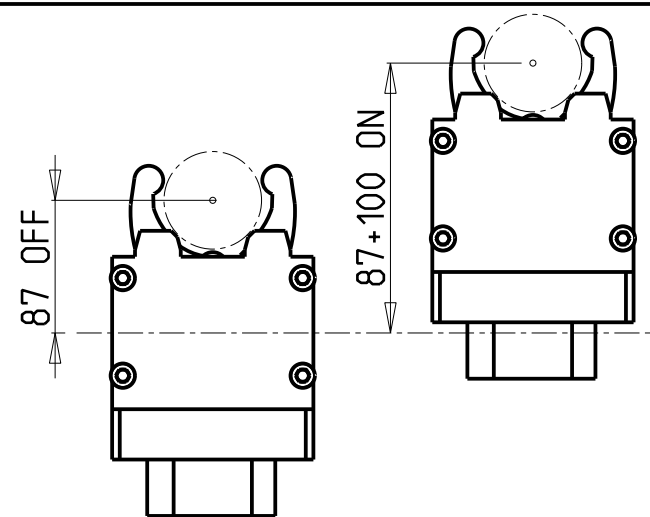
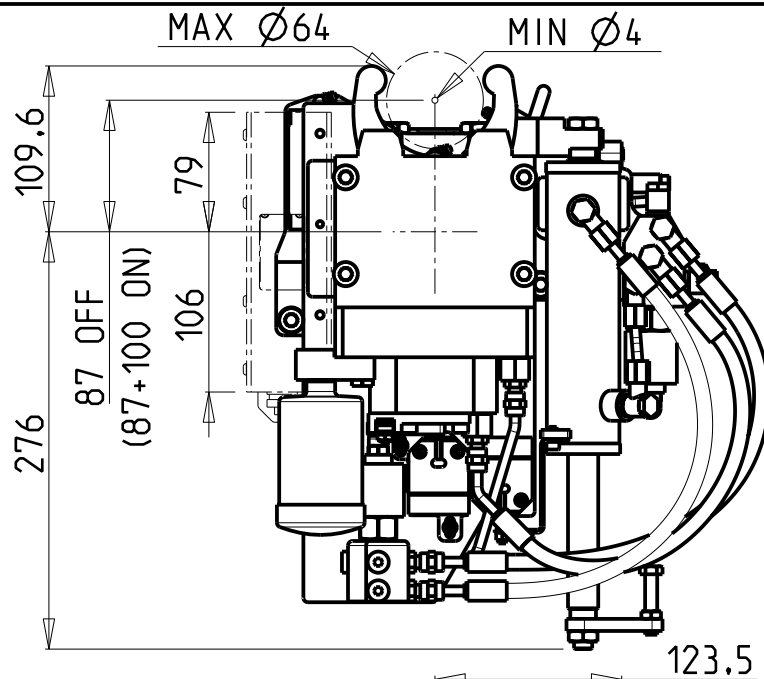
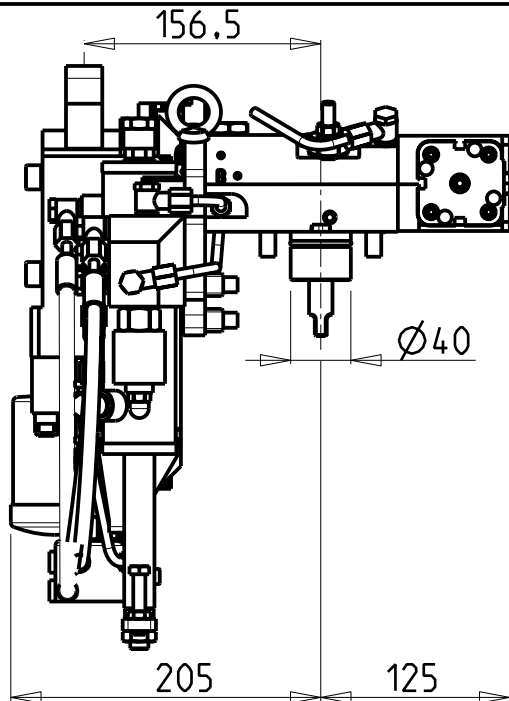

- # CON GESTIONE ELETTRONICA
APERTURA COMPLETA DELLA LUNETTA
- # With Electronic control of steady
rest arms complete opening
- # Mit vollständiger elektronischer
Öffnungsbedienung der Luenette

Cod. MT	I	RPM	Lubr.esterna Ext. coolant Aussenkuehlung
MNZ0310300	1:1	6000	X
# MNZ0310300EU	1:1	6000	X
# MNZ0310300US	1:1	6000	X
# MNZ0310300JP	1:1	6000	X

EUROPE - AFRICA -
MIDDLE EAST - NORTH ASIA

USA - CANADA - MEXICO -
AUSTRALIA - SOUTH ASIA

JAPAN

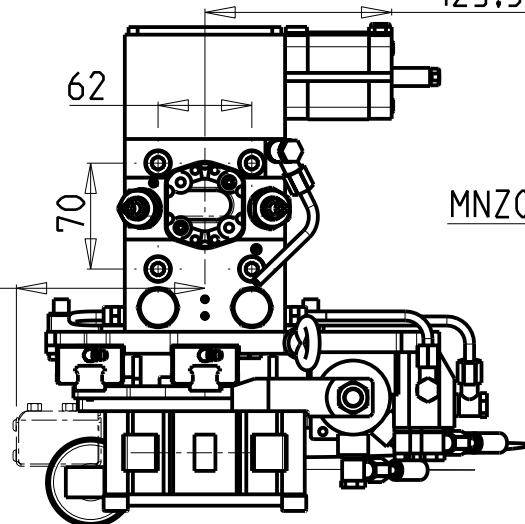

Only for
MNZ0310300JP

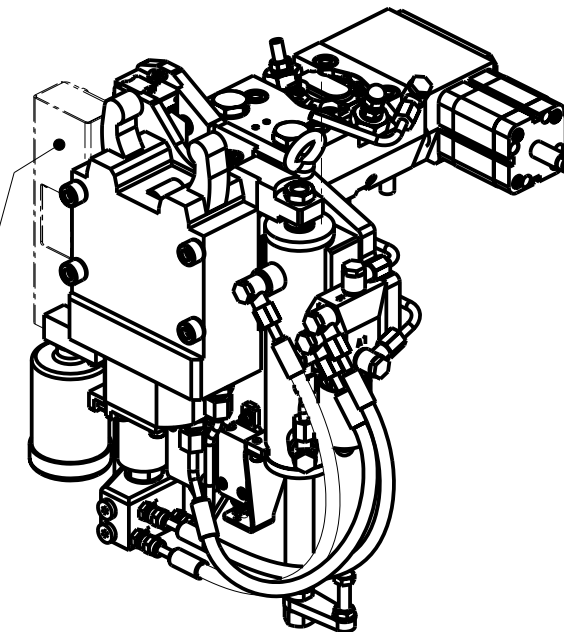

DMG-MORI
NZ1500/2000 - NZX1500/2000

MODULO MOTORIZZATO PER LUNETTA RETRATTILE (TAGLIA 1)
Driven toolholder for sliding steady rest (Size 1)
Luenettenwerkzeug zurueck versetzte Version (Grossse 1)

Subject to change without notice.

M.T. srl

Via Casino Albini 480
Tel. 0541/956034-957884
Fax 0541/956341
47842 S. GIOVANNI IN M. (RN)
e-mail: mtma@mtmarchetti.com
http://www.mtmarchetti.com

PRODUZIONE MODULI ROTANTI



PAGINA MNZ363-1-00

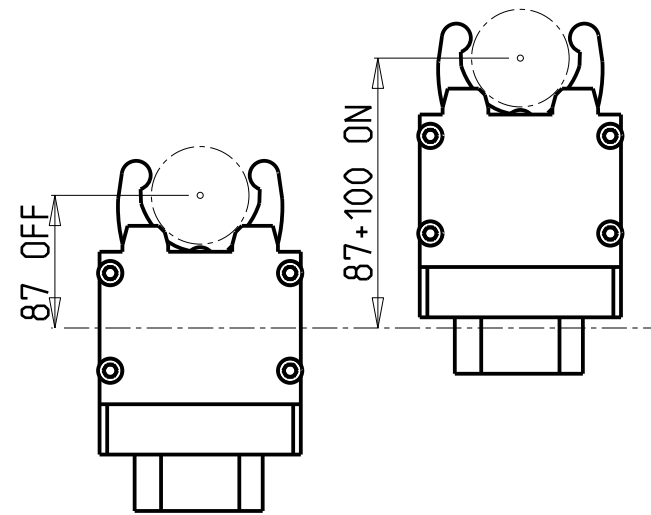
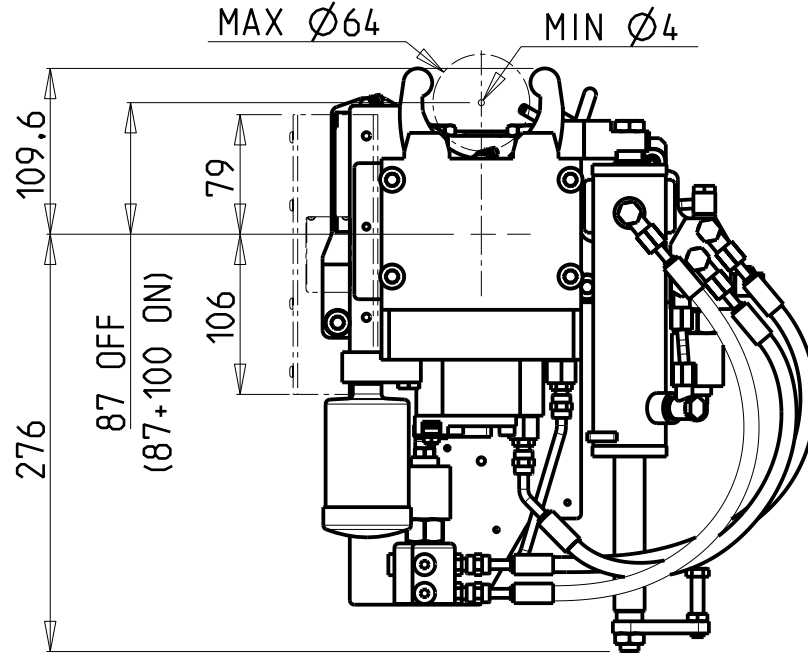
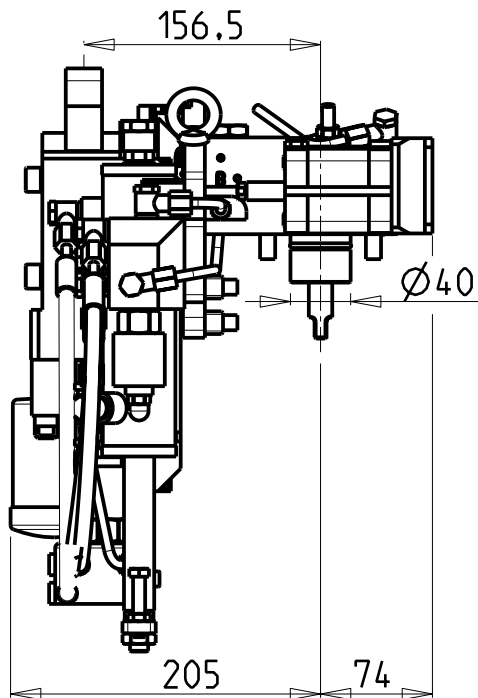

Only for
MNZ0310350JP

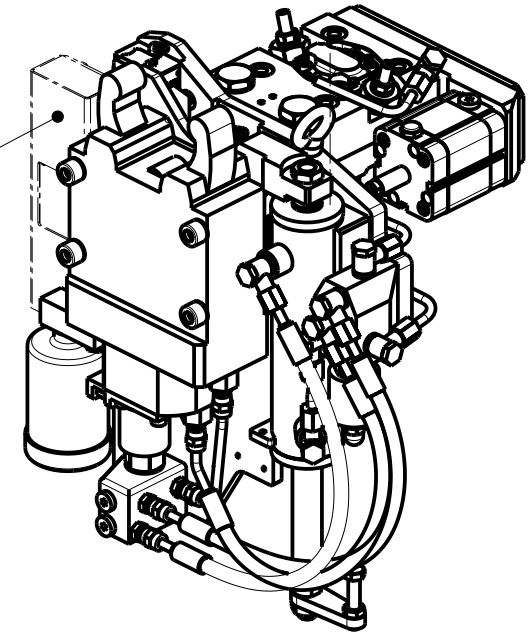

- # CON GESTIONE ELETTRONICA APERTURA COMPLETA DELLA LUNETTA
- # With Electronic control of steady rest arms complete opening
- # Mit vollstaendiger elektronischer Oeffnungsbedienung der Luenette

Cod. MT	I	RPM	Luhr.esterna Ext. coolant Aussenkuehlung	
MNZ0310350	1:1	6000	X	
# MNZ0310350EU	1:1	6000	X	EUROPE - AFRICA - MIDDLE EAST - NORTH ASIA
# MNZ0310350US	1:1	6000	X	USA - CANADA - MEXICO - AUSTRALIA - SOUTH ASIA
# MNZ0310350JP	1:1	6000	X	JAPAN

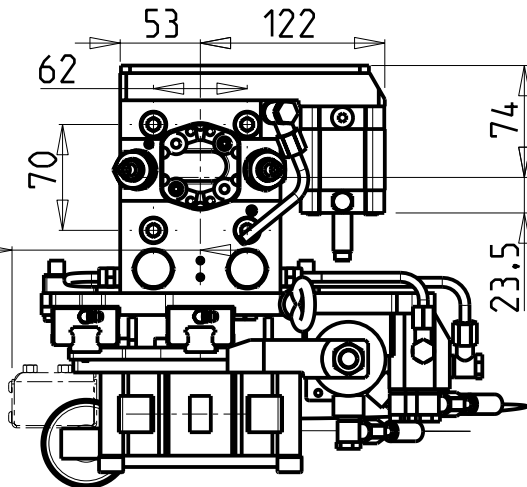

DMG-MORI
NZ1500/2000 - NZX1500/2000 - NT3000 SERIE - NT1000/2000 - NTX1000/2000

MODULO MOTORIZZATO PER LUNETTA RETRATTILE (TAGLIA 1)
Driven toolholder for sliding steady rest (Size 1)
Luenettenwerkzeug zurueck versetzte Version (Grossse 1)

Subject to change without notice.

M.T. srl

Via Casino Albini 480
Tel. 0541/956034-957884
Fax 0541/956341
47842 S. GIOVANNI IN M. (RN)
e-mail: mtma@mtmarchetti.com
http://www.mtmarchetti.com

PRODUZIONE MODULI ROTANTI



PAGINA MNZ363-1-10

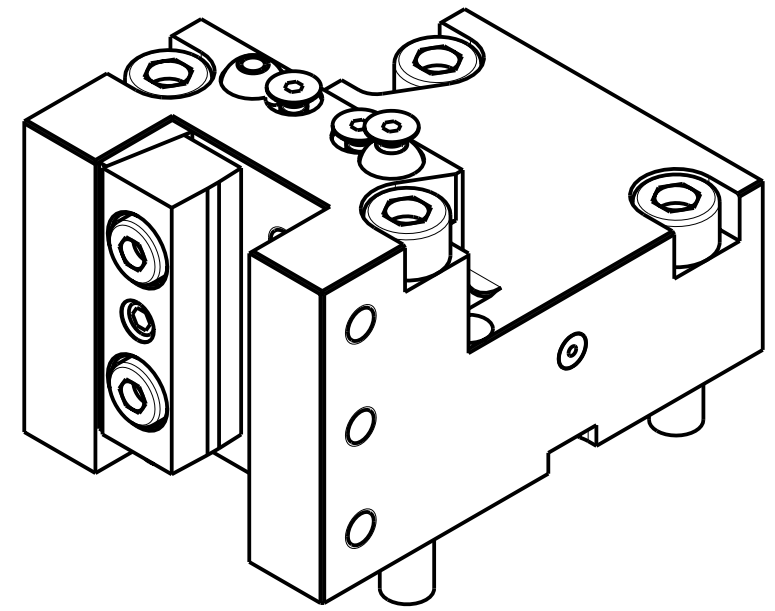
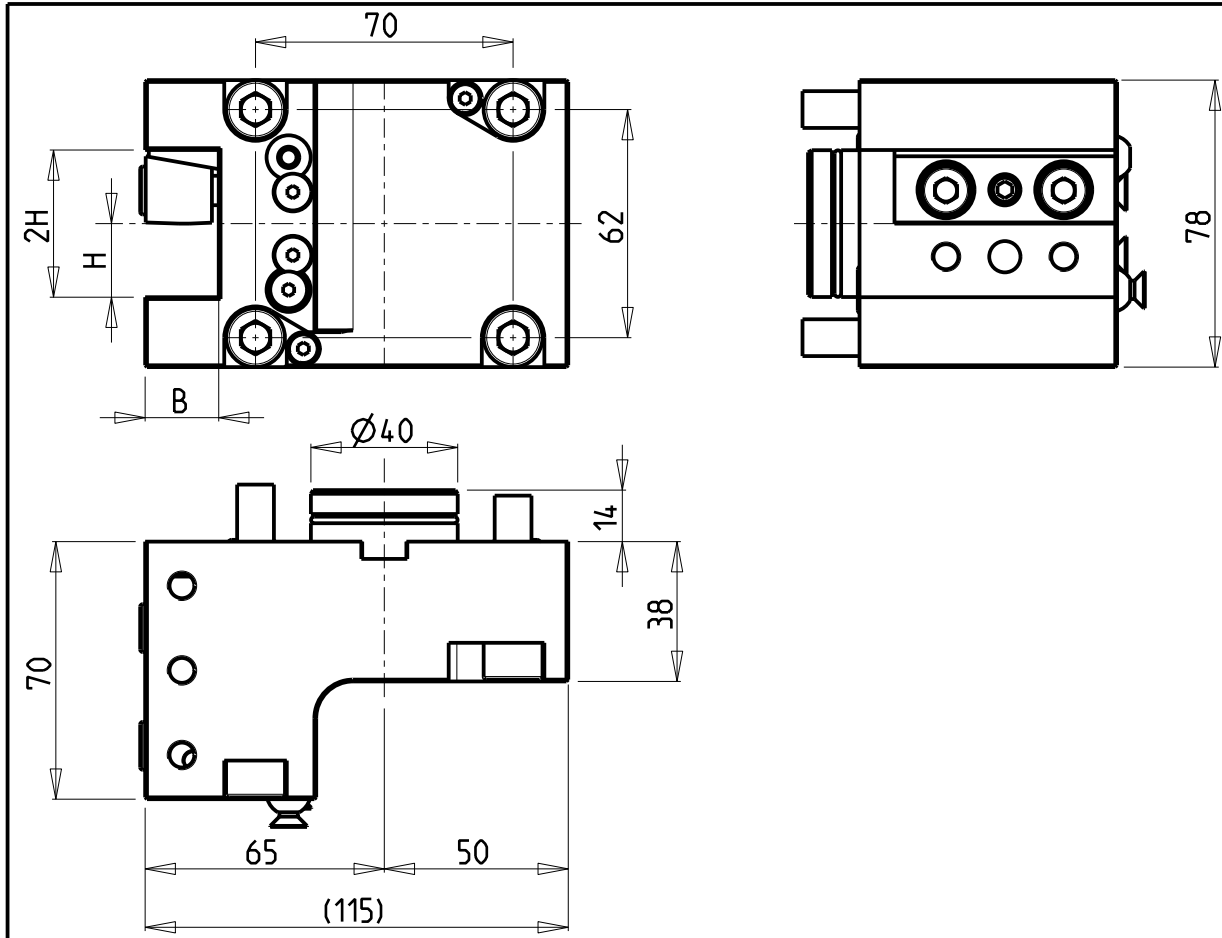

Cod. MT	N°Utensili N° Tools N° Werkzeuge	Reversibile lato mandrino/contromandrino Reversible sub/main spindle side Umkehrbare Spindel-seite/ Gegenspindel-seite	Misure Dimensions Masse	B	H
MNZ0092000	1/2	X	mm	20	20
MNZ0091905	1/2	X	Inch	3/4"	3/4"

DMG-MORI
 NZ1500/2000 - NZX1500/2000 - NT3000 SERIE - NL1500/2000/2500 20 STAZ. - NLX1500/2000/2500 20 STAZ.
 NT1000/2000 - NTX1000/2000 - NTX1000/2000/2500/3000 2ND GEN. 12ST. - DURATURN 2050MC/2550MC - NRX2000 - ALX1500/2000/2500

PORTAUTENSILE RADIALE SINGOLO QD=20mm / QD=3/4" H=70mm
 Radial single static tool QD=20mm / QD=3/4" H=70mm
 Radial Single-Werkzeughalter QD=20mm / QD=3/4" H=70mm

Subject to change without notice.

M.T. srl
 Via Casino Albini 480
 Tel. 0541/956034-957884
 Fax 0541/956341
 47842 S. GIOVANNI IN M. (RN)
 e-mail: mtma@mtmarchetti.com
 http://www.mtmarchetti.com

PRODUZIONE MODULI ROTANTI



PAGINA MNZ420-1-00

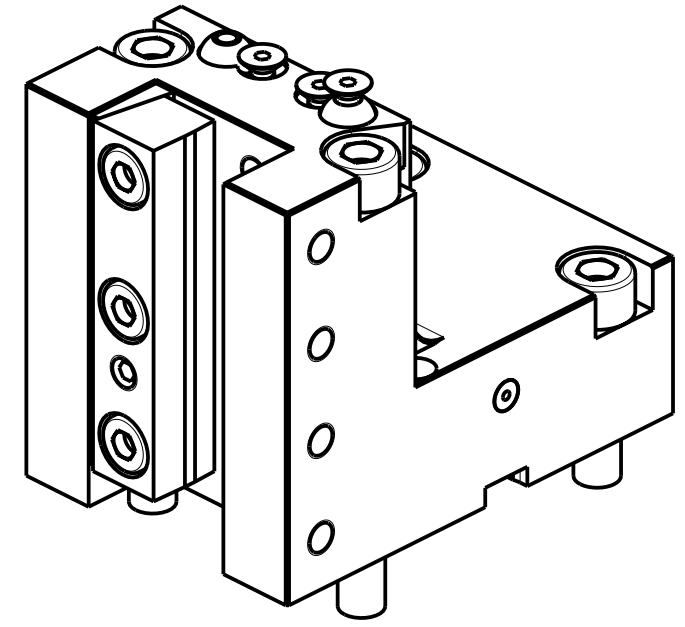
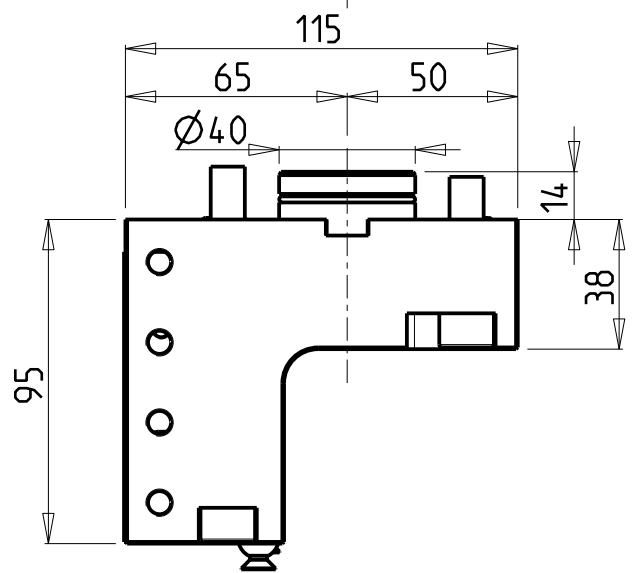
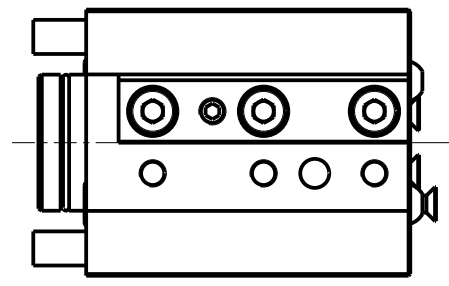
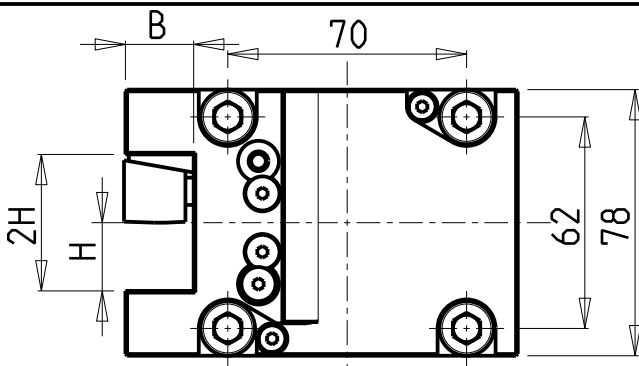

Cod. MT	N°Utensili N° Tools N° Werkzeuge	Reversibile lato mandrino/contromandrino Reversible sub/main spindle side Umkehrbare Spindel-seite/ Gegenspindel-seite	Misure Dimensions Masse	B	H
MNZ0092010	1/2	X	mm	20	20
MNZ0091915	1/2	X	Inch	3/4"	3/4"

DMG-MORI
 NZ1500/2000 - NZX1500/2000 - NT3000 SERIE - NL1500/2000/2500 20 STAZ. - NLX1500/2000/2500 20 STAZ.
 NT1000/2000 - NTX1000/2000 - NTX1000/2000/2500/3000 2ND GEN. 12ST. - DURATURN 2050MC/2550MC - NRX2000 - ALX1500/2000/2500

PORTAUTENSILE RADIALE SINGOLO QD=20mm / QD=3/4" H=95mm
 Radial single static tool QD=20mm / QD=3/4" H=95mm
 Radial Single-Werkzeughalter QD=20mm / QD=3/4" H=95mm

Subject to change without notice.

M.T. srl
 Via Casino Albini 480
 Tel. 0541/956034-957884
 Fax 0541/956341
 47842 S. GIOVANNI IN M. (RN)
 e-mail: mtma@tmarchetti.com
 http://www.tmmarchetti.com

PRODUZIONE MODULI ROTANTI



PAGINA MNZ420-1-10

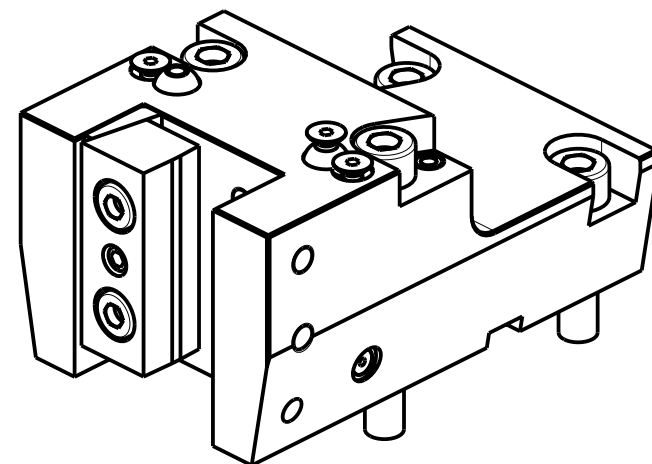
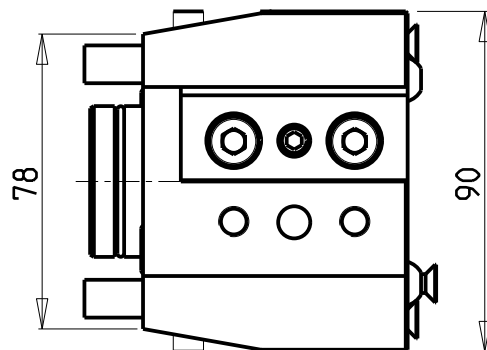
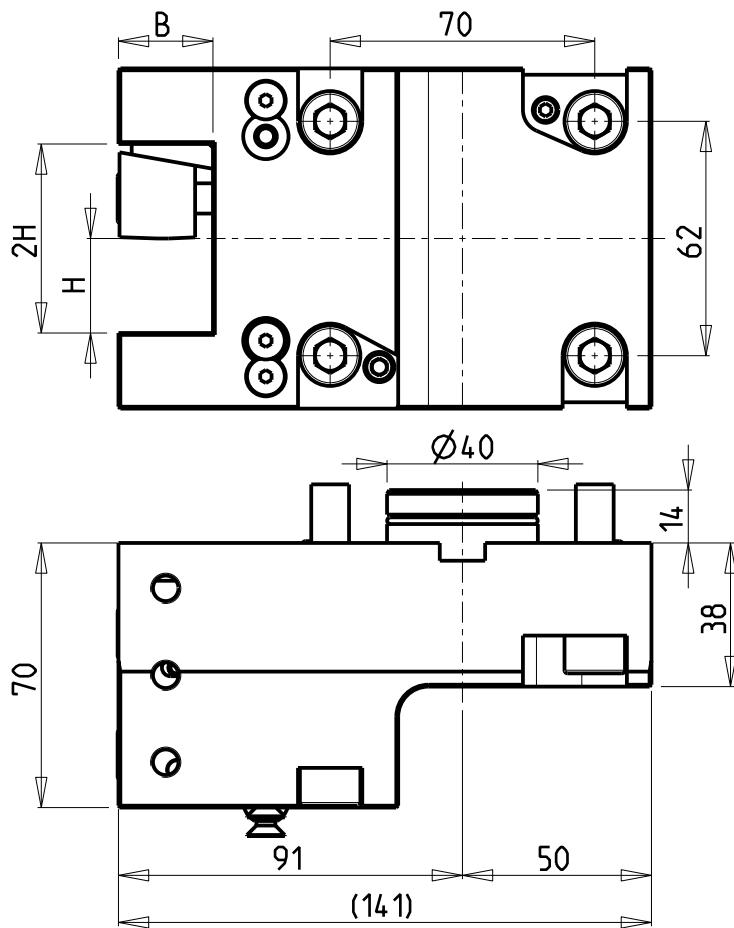

Cod. MT	N°Utensili N°Tools N°Werkzeuge	Reversibile lato mandrino/contromandrino Reversible sub/main spindle side Umkehrbare Spindel-seite/ Gegenspindel-seite	Misure Dimensions Masse	B	H
MNZ0092500	1	X	mm	25	25
MNZ0092540	1	X	Inch	1"	1"

DMG-MORI

NZ1500/2000 - NZX1500/2000 - NT3000 SERIE - NL1500/2000/2500 20 STAZ. - NLX1500/2000/2500 20 STAZ.
NT1000/2000 - NTX1000/2000 - NTX1000/2000/2500/3000 2ND GEN. 12ST. - DURATURN 2050MC/2550MC - NRX2000 - ALX1500/2000/2500

PORTAUTENSILE RADIALE SINGOLO QD=25mm / QD=1" H=70mm

Radial single static tool QD=25mm / QD=1" H=70mm

Radial Single-Werkzeughalter QD=25mm / QD=1" H=70mm

Subject to change without notice.

M.T. srl

Via Casino Albini 480

Tel. 0541/956034-957884

Fax 0541/956341

47842 S. GIOVANNI IN M. (RN)

e-mail: mtma@mtmarchetti.com

http://www.mtmarchetti.com

PRODUZIONE MODULI ROTANTI



PAGINA MNZ423-1-00

10/2018

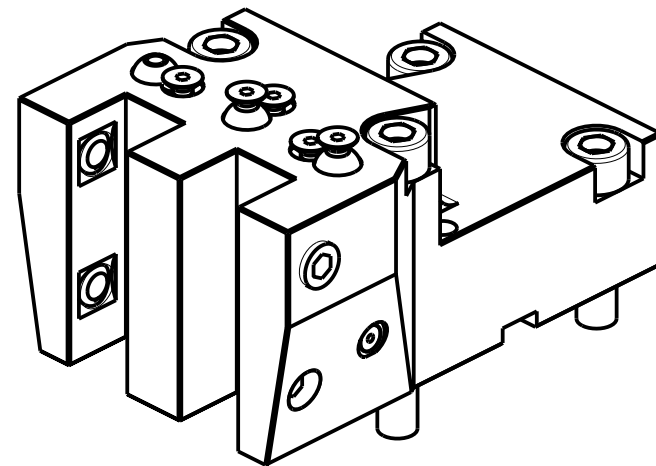
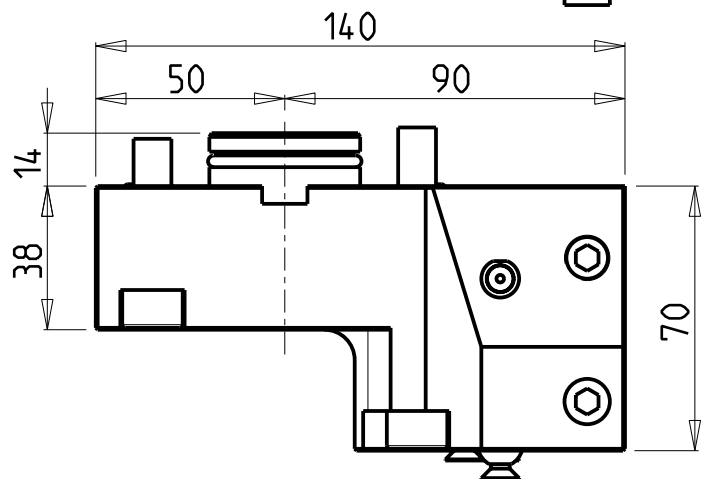
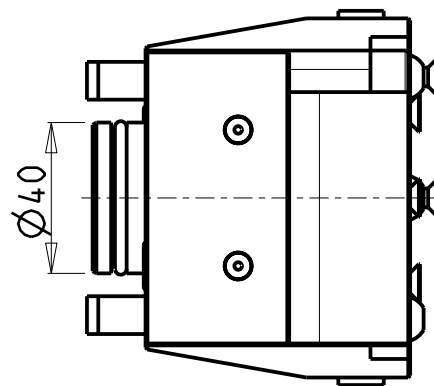
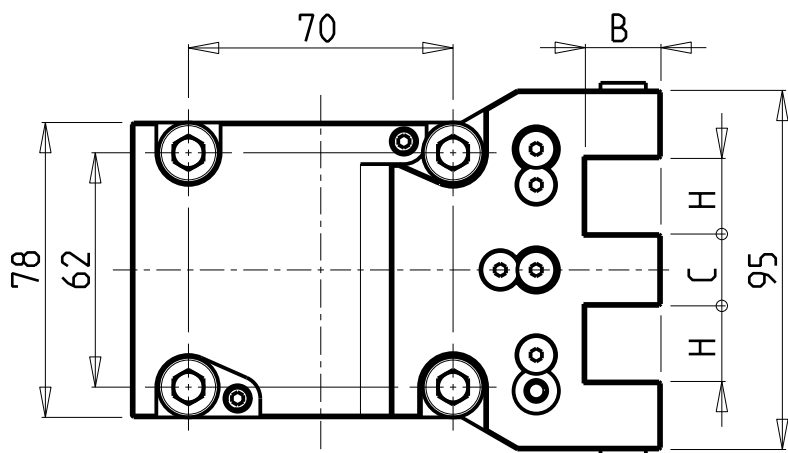

Cod. MT	N°Utensili N° Tools N° Werkzeuge	Reversibile lato mandrino/contromandrino Reversible sub/main spindle side Umkehrbare Spindel-seite/ Gegenspindel-seite	Misure Dimensions Masse	B	H	C
MNZ0102000	2	X	mm	20	20	19
MNZ0101905	2	X	Inch	3/4"	3/4"	0.822"

DMG-MORI

NZ1500/2000 - NZX1500/2000 - NT3000 SERIE - NL1500/2000/2500 20 STAZ. - NLX1500/2000/2500 20 STAZ.
 NT1000/2000 - NTX1000/2000 - NTX1000/2000/2500/3000 2ND GEN. 12ST. - DURATURN 2050MC/2550MC - ALX1500/2000/2500

PORTAUTENSILE RADIALE SOVRAPPOSTO QD=20mm / QD=3/4" H=70mm

Radial single side twin static tool QD=20mm / QD=3/4" H=70mm

Radial Werkzeughalter ueberlagert QD=20mm / QD=3/4" H=70mm

Subject to change without notice.

M.T. srl

Via Casino Albini 480
 Tel. 0541/956034-957884
 Fax 0541/956341
 47842 S. GIOVANNI IN M. (RN)
 e-mail: mtma@mtmarchetti.com
 http://www.mtmarchetti.com

PRODUZIONE MODULI ROTANTI



PAGINA MNZ440-1-00

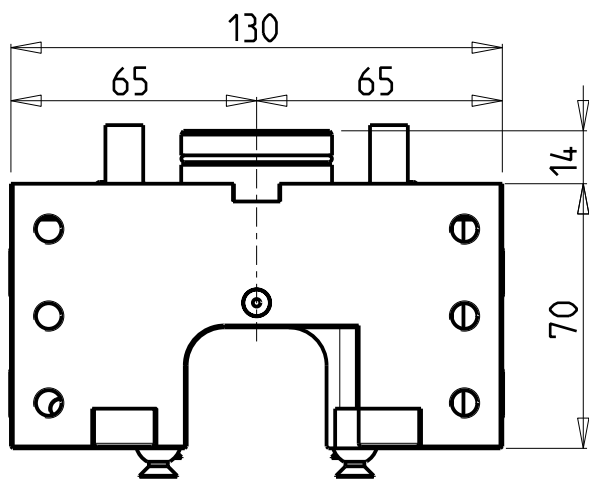
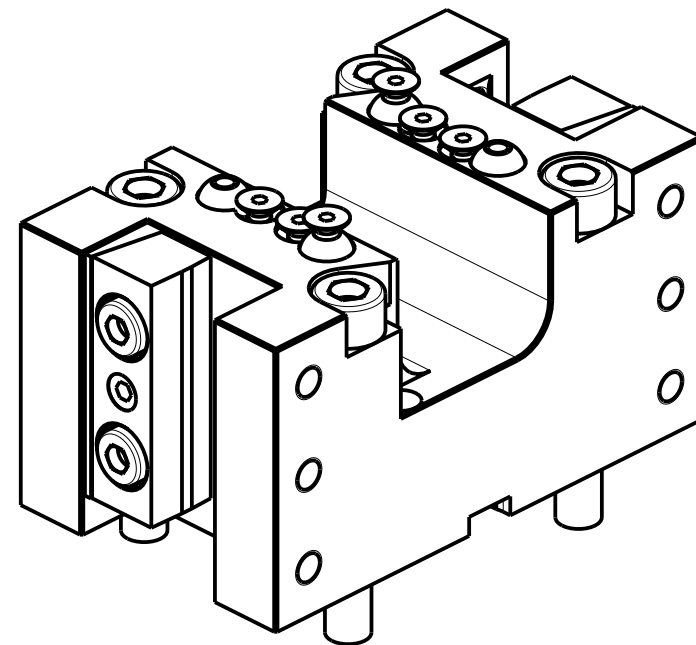
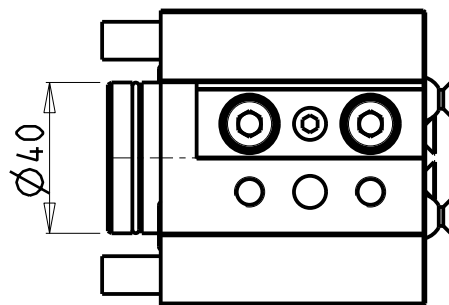
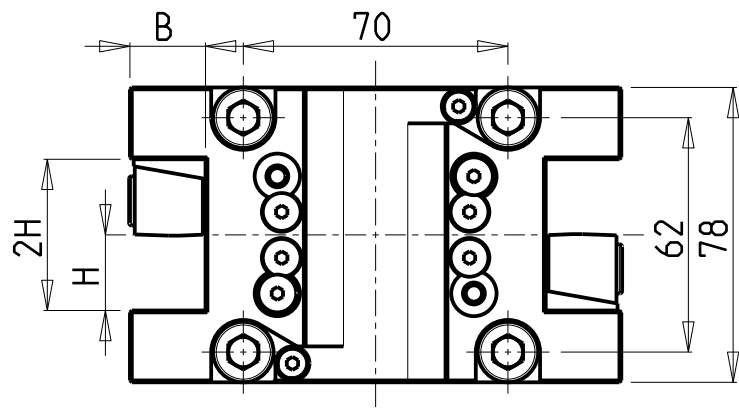

Cod. MT	N°Utensili N°Tools N°Werkzeuge	Reversibile lato mandrino/controlmandrino Reversible sub/main spindle side Umkehrbare Spindel-seite/ Gegenspindel-seite	Misure Dimensions Masse	B	H
MNZ0112000	2/4	X	mm	20	20
MNZ0111905	2/4	X	Inch	3/4"	3/4"

DMG-MORI

NZ1500/2000 - NZX1500/2000 - NT3000 SERIE - NL1500/2000/2500 20 STAZ. - NLX1500/2000/2500 20 STAZ.
 NT1000/2000 - NTX1000/2000 - NTX1000/2000/2500/3000 2ND GEN. 12ST. - DURATURN 2050MC/2550MC - ALX1500/2000/2500

PORTAUTENSILE RADIALE DOPPIO QD=20mm / QD=3/4" H=70mm

Radial double static tool QD=20mm / QD=3/4" H=70mm

Radial Doppel-Werkzeughalter QD=20mm / QD=3/4" H=70mm

Subject to change without notice.

M.T. srl

Via Casino Albini 480
 Tel. 0541/956034-957884
 Fax 0541/956341
 47842 S. GIOVANNI IN M. (RN)
 e-mail: mtma@mtmarchetti.com
<http://www.mtmarchetti.com>

PRODUZIONE MODULI ROTANTI



PAGINA MNZ450-1-00

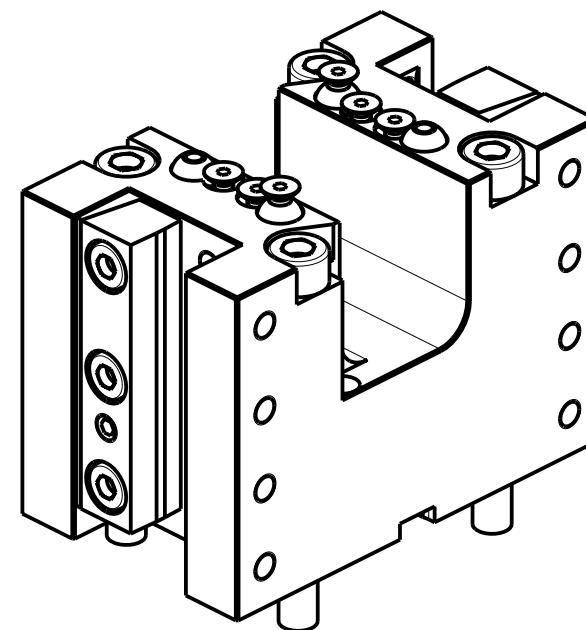
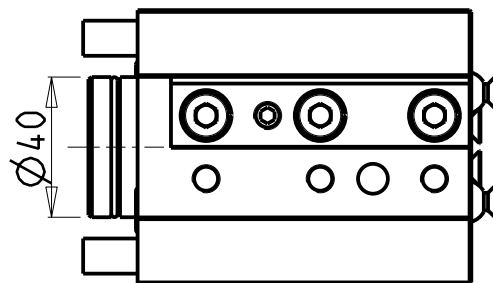
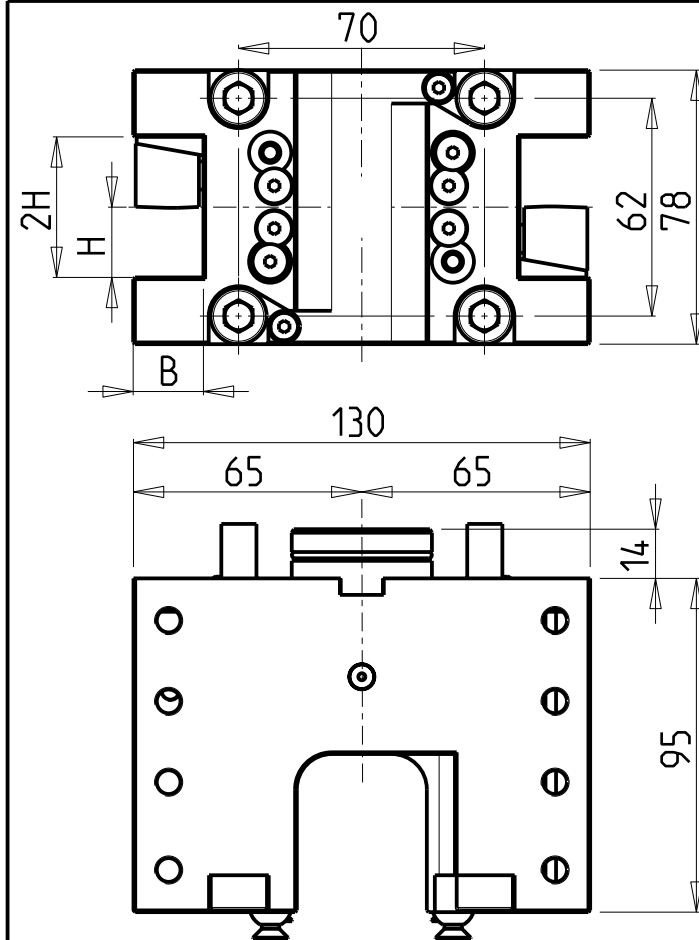

Cod. MT	N°Utensili N° Tools N° Werkzeuge	Reversibile lato mandrino/contromandrino Reversible sub/main spindle side Umkehrbare Spindel-seite/ Gegenspindel-seite	Misure Dimensions Masse	B	H
MNZ0112010	2/4	X	mm	20	20
MNZ0111915	2/4	X	Inch	3/4"	3/4"

DMG-MORI

NZ1500/2000 - NZX1500/2000 - NT3000 SERIE - NL1500/2000/2500 20 STAZ. - NLX1500/2000/2500 20 STAZ.
 NT1000/2000 - NTX1000/2000 - NTX1000/2000/2500/3000 2ND GEN. 12ST. - DURATURN 2050MC/2550MC - ALX1500/2000/2500

PORTAUTENSILE RADIALE DOPPIO QD=20mm / QD=3/4" H=95mm

Radial double static tool QD=20mm / QD=3/4" H=95mm

Radial Doppel-Werkzeughalter QD=20mm / QD=3/4" H=95mm

Subject to change without notice.

M.T. srl

Via Casino Albini 480
 Tel. 0541/956034-957884
 Fax 0541/956341

47842 S. GIOVANNI IN M. (RN)
 e-mail: mtma@mtmarchetti.com
 http://www.mtmarchetti.com

PRODUZIONE MODULI ROTANTI



PAGINA MNZ450-1-10

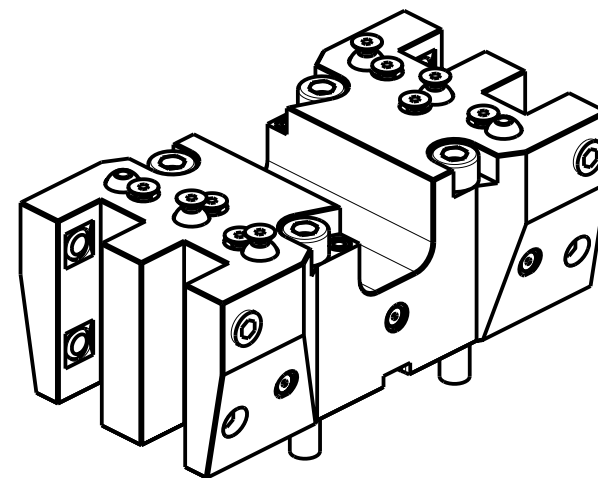
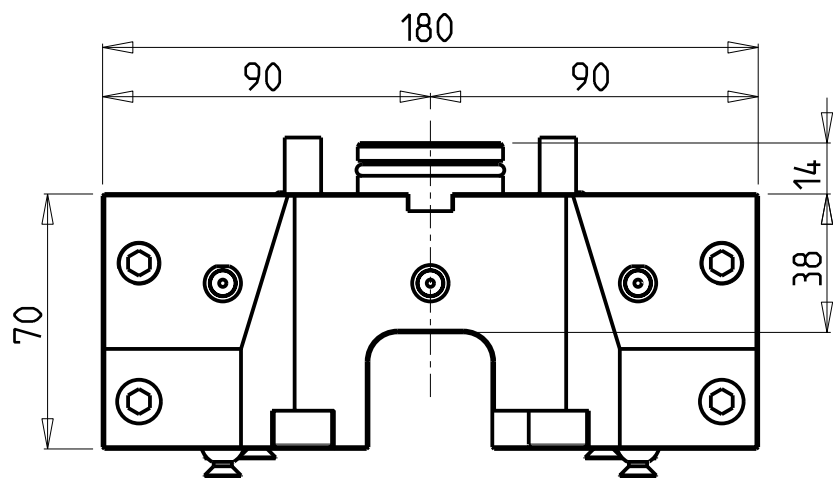
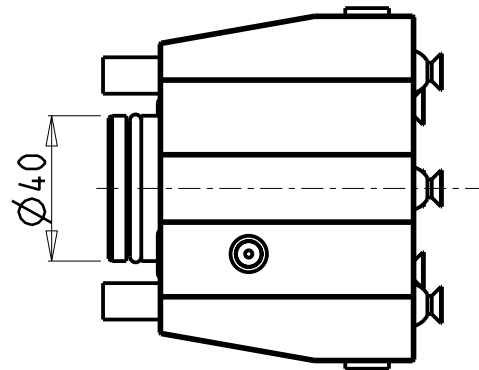
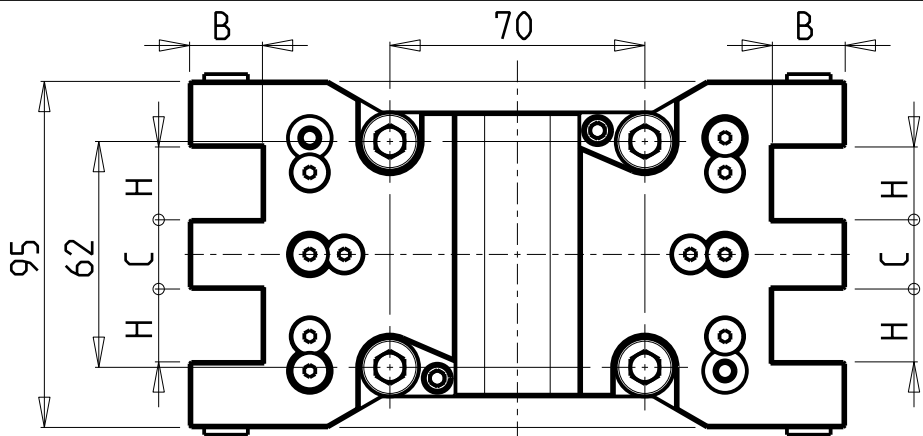

Cod. MT	N°Utensili N°Tools N°Werkzeuge	Reversibile lato mandrino/contromandrino Reversible sub/main spindle side Umkehrbare Spindel-seite/ Gegenspindel-seite	Misure Dimensions Masse	B	H	C
MNZ0122000	4	X	mm	20	20	19
MNZ0121905	4	X	Inch	3/4"	3/4"	0.822"

DMG-MORI

NZ1500/2000 - NZX1500/2000 - NT3000 SERIE - NL1500/2000/2500 20 STAZ. - NLX1500/2000/2500 20 STAZ.
 NT1000/2000 - NTX1000/2000 - DURATURN 2050MC/2550MC - ALX1500/2000/2500

PORTAUTENSILE RADIALE DOPPIO SOVRAPPOSTO QD=20mm / QD=3/4" H=70mm

Radial double side twin static tool QD=20mm / QD=3/4" H=70mm

Radial Doppel-Werkzeughalter ueberlagert QD=20mm / QD=3/4" H=70mm

Subject to change without notice.

M.T. srl

Via Casino Albini 480
 Tel. 0541/956034-957884
 Fax 0541/956341
 47842 S. GIOVANNI IN M. (RN)
 e-mail: mtma@mtmarchetti.com
 http://www.mtmarchetti.com

PRODUZIONE MODULI ROTANTI



PAGINA MNZ460-1-00

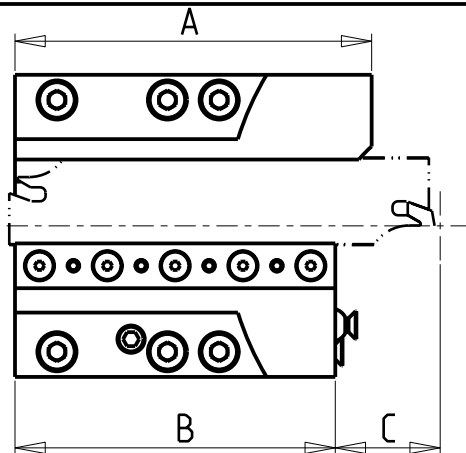
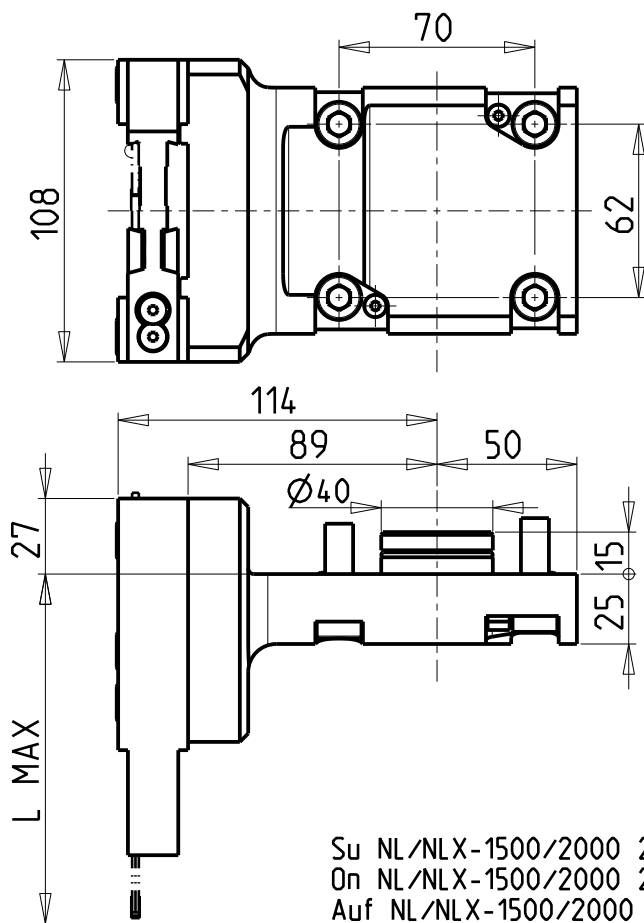

POSSIBILITA' DI LAVORO M3/M4
 OPTION OF M3/M4 WORKING
 ARBEITSMOGLICHKEIT M3/M4

Su NL/NLX-1500/2000 20 stazioni il portautensile cod. MNZ0180132 è fuori volteggio
 On NL/NLX-1500/2000 20 st. the blade holder cod. MNZ0180132 is out of rotation
 Auf NL/NLX-1500/2000 20 st. ist das Abstechhalter cod. MNZ0180132 ausser Raumbedarf

DOTAZIONI - SUPPLIED WITH - AUSSTATTUNG

- N°1 - LAMA - BLADE - KLINGE ISCAR H=32 Sp. 3/4mm (KENNAMETAL OPTIONAL)
- N°10 - INSERTI - INSERTS - EINLAGEN
- N°1 - CHIAVE A T PER MONTAGGIO INSERTI
 - T-WRENCH FOR INSERT SET UP
 - T-SCHLUESSEL FUER EINSATZSTUECK-MONTAGE

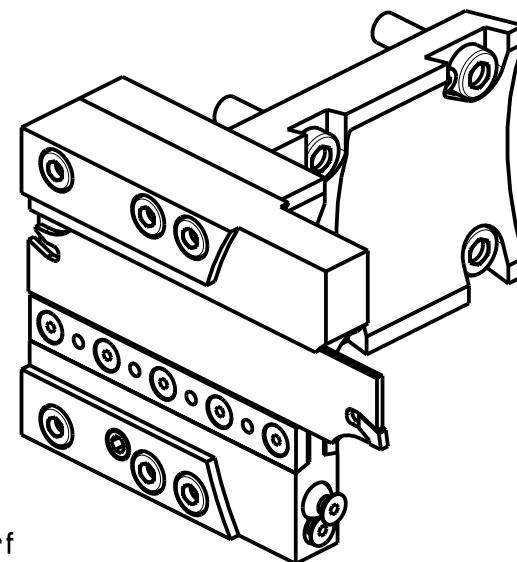

Cod. MT	N°Utensili N°Tools N°Werkzeuge	Reversibile lato mandrino/contromandrino Reversible sub/main spindle side Umkehrbare Spindelseite/ Gegenspindelseite	A	B	C	L MAX
MNZ0180132	1	X	127.5	113	39	125
MNZ0180232	1	X	114.5	100	52	115

DMG-MORI

NZ1500/2000 - NZX1500/2000 - NT3000 SERIE - NL1500/2000/2500 20 STAZ. - NLX1500/2000/2500 20 STAZ.
 NT1000/2000 - NTX1000/2000/2500/3000 2ND GEN. 12ST. - DURATURN 2050MC/2550MC - ALX1500/2000/2500

PORTAUTENSILE PER LAMA DOPPIO

Radial double blade holder
 Radial Doppel Abstechhalter

Subject to change without notice.

M.T. srl

Via Casino Albini 480
 Tel. 0541/956034-957884
 Fax 0541/956341
 47842 S. GIOVANNI IN M. (RN)
 e-mail: mtma@mtmarchetti.com
 http://www.mtmarchetti.com

PRODUZIONE MODULI ROTANTI



PAGINA MNZ520-1-00

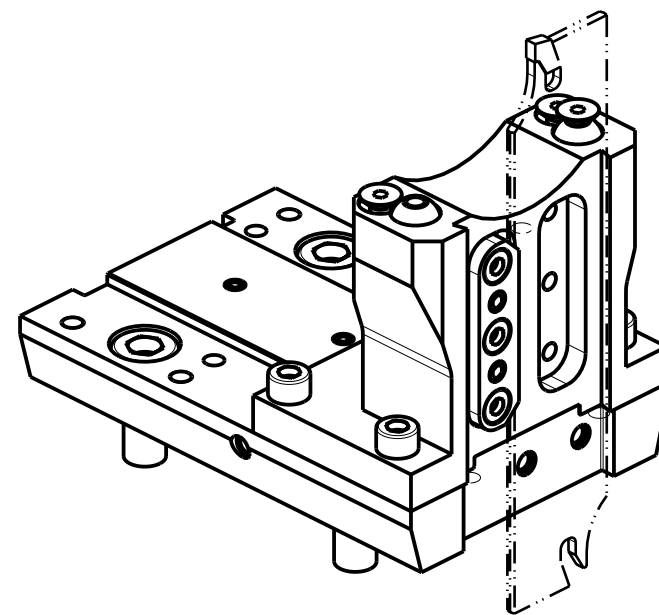
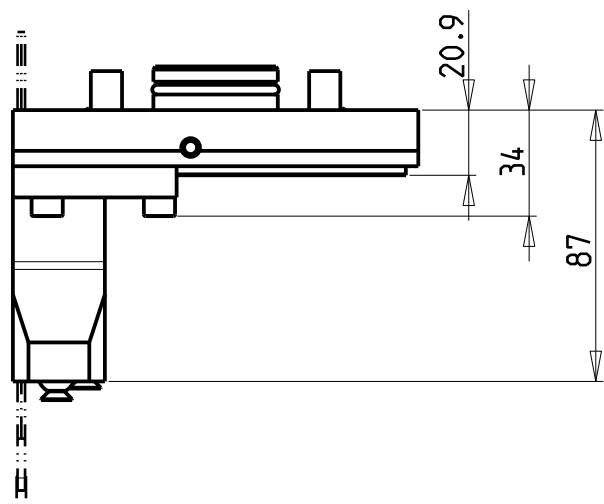
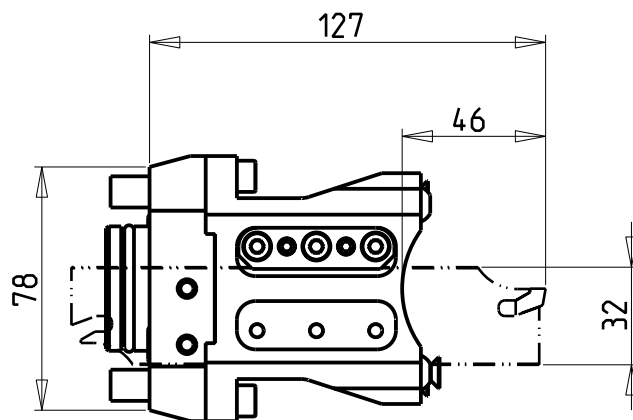
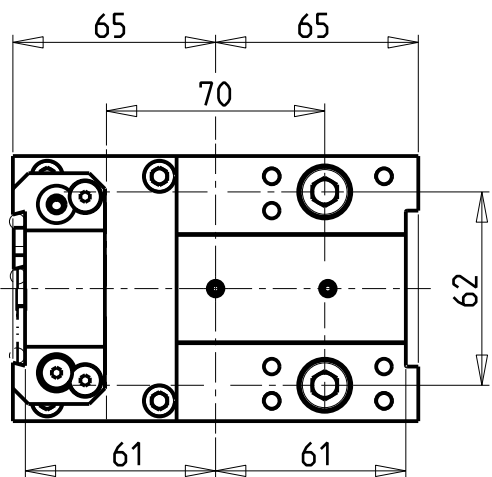

POSSIBILITA' DI LAVORO M3/M4
 OPTION OF M3/M4 WORKING
 ARBEITSMÖGLICHKEIT M3/M4

DOTAZIONI - SUPPLIED WITH - AUSSTATTUNG

N°1 - LAMA - BLADE - KLINGE ISCAR H=32 Sp. 3/4mm
 (KENNAMETAL OPTIONAL)

N°10 - INSERTI - INSERTS - EINLAGEN

N°1 - CHIAVE A T PER MONTAGGIO INSERTI
 - T-WRENCH FOR INSERT SET UP
 - T-SCHLUESSEL FUER EINSATZSTUECK-MONTAGE

Cod. MT	N°Utensili N°Tools N°Werkzeuge	Reversibile lato mandrino/contromandrino Reversible sub/main spindle side Umkehrbare Spindel-seite/ Gegenspindel-seite	Lubr.esterna Ext. coolant Aussenkuehlung
MNZ0380132	1	X	X

DMG-MORI

NZ1500/2000 - NZX1500/2000 - NT3000 SERIE - NL1500/2000/2500 20 STAZ. - NLX1500/2000/2500 20 STAZ.
 NT1000/2000 - NTX1000/2000/2500/3000 2ND GEN. 12ST. - DURATURN 2050MC/2550MC - NRX2000 - ALX1500/2000/2500

PORTAUTENSILE RADIALE PER LAMA

Radial blade holder
 Radial Abstechhalter

M.T. srl

Via Casino Albini 480
 Tel. 0541/956034-957884
 Fax 0541/956341
 47842 S. GIOVANNI IN M. (RN)
 e-mail: mtma@mtmarchetti.com
 http://www.mtmarchetti.com

PRODUZIONE MODULI ROTANTI



PAGINA MNZ520-1-01

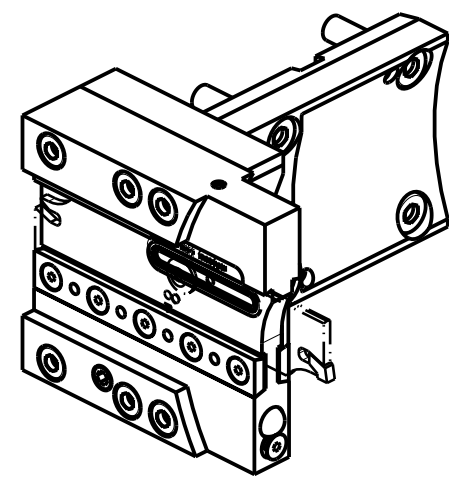
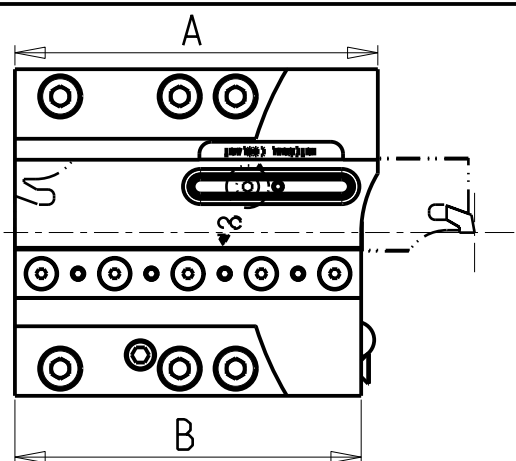
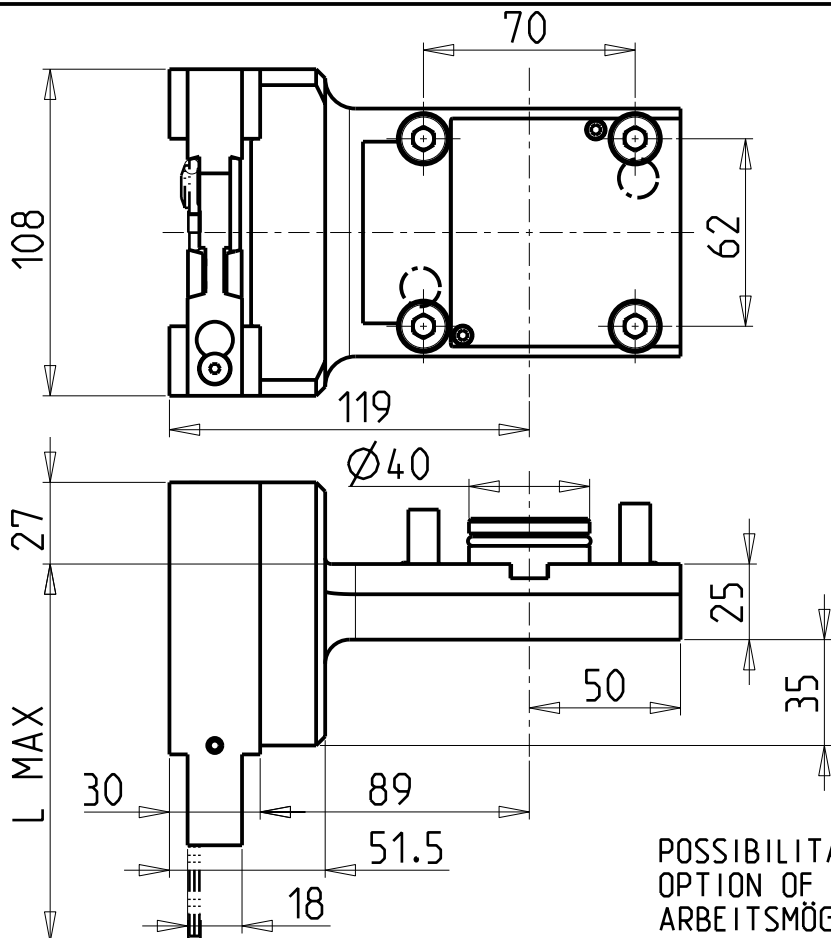

Su NL/NLX-1500/2000 20 stazioni il portautensile cod. MNZ0520132 è fuori rotazione
 On NL/NLX-1500/2000 20 st. the blade holder cod. MNZ0520132 is out of rotation
 Auf NL/NLX-1500/2000 20 st. ist das Abstechhalter cod. MNZ0520132 ausser Raumbedarf

POSSIBILITA' DI LAVORO M3/M4
 OPTION OF M3/M4 WORKING
 ARBEITSMÖGLICHKEIT M3/M4

- KIT LAME NON INCLUSI (OPZIONALI)**
BLADES NOT SUPPLIED WITH (OPTIONAL)
KLINGEN NICHT INBEGRIFFEN (OPTIONAL)
- LAMA-BLADE-KLINGE SANDVIK H=32 sp.3 cod. QD_NN2G60C25A +INSERTI-INSERTS-EINLAGEN cod. QD_NG_0300_0002_CM_1145 (10 pz.)
 - LAMA-BLADE-KLINGE SANDVIK H=32 sp.4 cod. QD_NN2H60C25A +INSERTI-INSERTS-EINLAGEN cod. QD_NH_0400_0002_CM_1145 (10 pz.)
 - LAMA-BLADE-KLINGE ISCAR H=32 sp.3 cod. SGFH_32K_3 +INSERTI-INSERTS-EINLAGEN cod. 6011365 (10pz.)
 - LAMA-BLADE-KLINGE ISCAR H=32 sp.4 cod. SGFH_32K_4 +INSERTI-INSERTS-EINLAGEN cod. 6011366 (10pz.)
 - LAMA-BLADE-KLINGE WALTER H=32 sp.3 cod. G2042.32N-3T45SX-P +INSERTI-INSERTS-EINLAGEN cod. SX-3E300N02-CE4 WSM33S (10pz.) + CHIAVE-KEY cod. FS1494
 - LAMA-BLADE-KLINGE WALTER H=32 sp.4 cod. G2042.32N-4T50SX-P +INSERTI-INSERTS-EINLAGEN cod. SX-4E400N02-CE4 WSM33S (10pz.) + CHIAVE-KEY cod. FS1494

Cod. MT	N°Utensili N° Tools N° Werkzeuge	Lubr.esterna Ext. coolant Aussenkuehlung	Lubr.interna Coolant through Innenkuehlung	A	B	L MAX
MNZ0520132	1	X	P=70bar	120	114.5	125 (122 ISCAR)
MNZ0520232	1	X	P=70bar	107	100	115 (108 ISCAR)

DMG-MORI
 NZ1500/2000 - NZX1500/2000 - NT3000 SERIE - NL1500/2000/2500 20 STAZ. - NLX1500/2000/2500 20 STAZ.
 NT1000/2000 - NTX1000/2000/2500/3000 2ND GEN. 12ST. - DURATURN 2050MC/2550MC - ALX1500/2000/2500
PORTAUTENSILE PER LAMA DOPPIO CON LUBRIFICAZIONE INTERNA
 Radial double blade holder with internal coolant
 Radial Doppel-Abstechhalter mit Innenkuehlung

Subject to change without notice.

M.T. srl
 Via Casino Albini 480
 Tel. 0541/956034-957884
 Fax 0541/956341
 47842 S. GIOVANNI IN M. (RN)
 e-mail: mtma@mtmarchetti.com
 http://www.mtmarchetti.com

PRODUZIONE MODULI ROTANTI

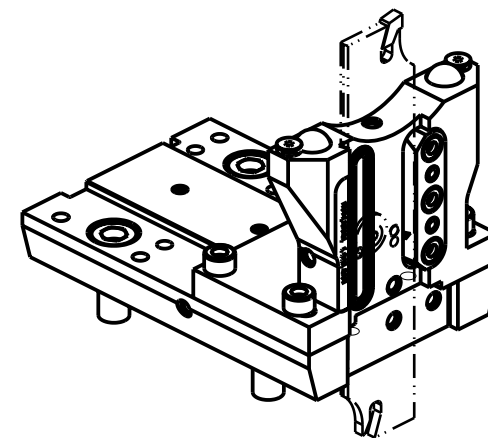
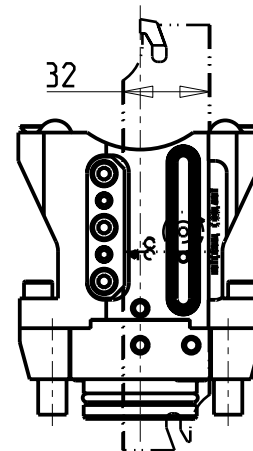
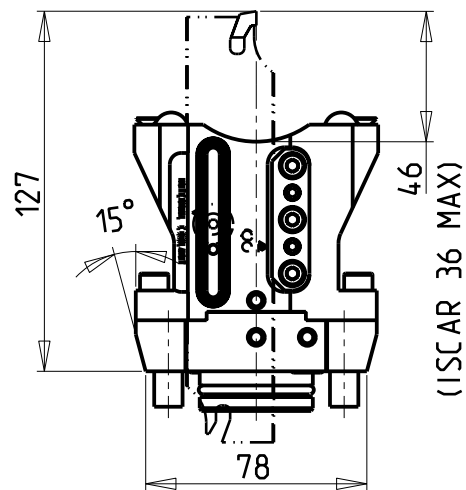
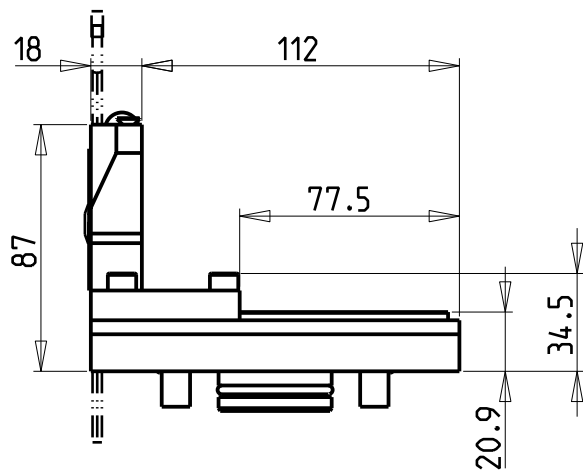
 PAGINA MNZ520-1-04

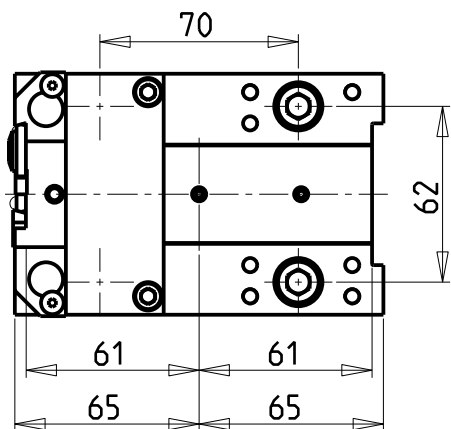

versione dx
right version
version rechts

versione sx
left version
version links



**KIT LAME NON INCLUSI (OPZIONALI)
BLADES NOT SUPPLIED WITH (OPTIONAL)
KLINGEN NICHT INBEGRIFFEN (OPTIONAL)**

- LAMA-BLADE-KLINGE SANDVIK H=32 sp.3 cod. QD_NN2G60C 25A
+INSERTI-INSERTS-EINLAGEN cod. QD_NG_0300_0002_CM_1145 (10 pz.)
- LAMA-BLADE-KLINGE SANDVIK H=32 sp.4 cod. QD_NN2H60C 25A
+INSERTI-INSERTS-EINLAGEN cod. QD_NH_0400_0002_CM_1145 (10 pz.)
- LAMA-BLADE-KLINGE ISCAR H=32 sp.3 cod. SGFH_32K_3
+INSERTI-INSERTS-EINLAGEN cod. 6011365 (10pz.)
- LAMA-BLADE-KLINGE ISCAR H=32 sp.4 cod. SGFH_32K_4
+INSERTI-INSERTS-EINLAGEN cod. 6011366 (10pz.)
- LAMA-BLADE-KLINGE WALTER H=32 sp.3 cod. G2042.32N-3T45SX-P
+INSERTI-INSERTS-EINLAGEN cod. SX-3E300N02-CE4 WSM33S (10pz.) + CHIAVE-KEY cod. FS1494
- LAMA-BLADE-KLINGE WALTER H=32 sp.4 cod. G2042.32N-4T50SX-P
+INSERTI-INSERTS-EINLAGEN cod. SX-4E400N02-CE4 WSM33S (10pz.) + CHIAVE-KEY cod. FS1494

Cod. MT		N°Utensili N°Tools N°Werkzeuge	Reversibile lato mandrino/contromandrino Reversible sub/main spindle side Umkehrbare Spindel-seite/ Gegenspindel-seite	Lubr.esterna Ext. coolant Aussenkuehlung	Lubr.interna Coolant through Innenkuehlung
versione dx right version version rechts	versione sx left version version links				
MNZ0530132R	MNZ0530132L	1	X	X	P=70bar

DMG-MORI

NZ1500/2000 - NZX1500/2000 - NT3000 SERIE - NL1500/2000/2500 20 STAZ. - NLX1500/2000/2500 20 STAZ.
NT1000/2000 - NTX1000/2000/2500/3000 2ND GEN. 12ST. - DURATURN 2050MC/2550MC - NRX2000 - ALX1500/2000/2500

PORTAUTENSILE RADIALE PER LAMA CON LUBRIFICAZIONE INTERNA

Radial blade holder with internal coolant

Radial Abstechhalter mit Innenkuehlung

Subject to change without notice.

M.T. srl

Via Casino Albini 480
Tel. 0541/956034-957884
Fax 0541/956341
47842 S. GIOVANNI IN M. (RN)
e-mail: mtma@mtmarchetti.com
http://www.mtmarchetti.com

PRODUZIONE MODULI ROTANTI



PAGINA MNZ520-1-05

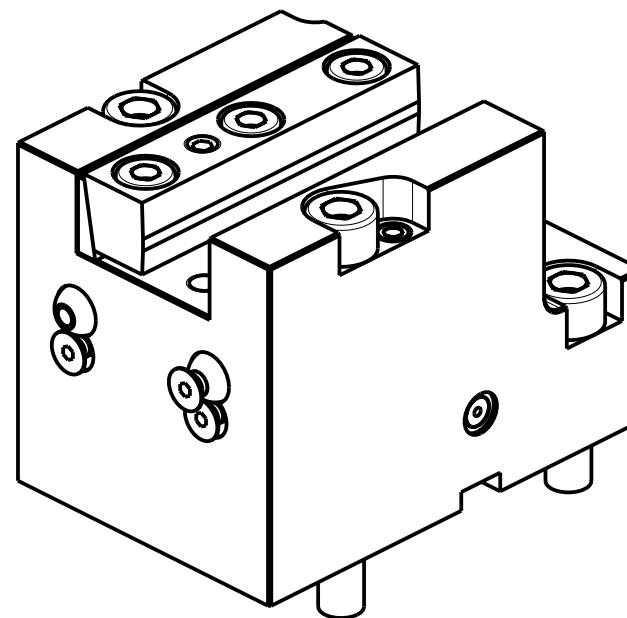
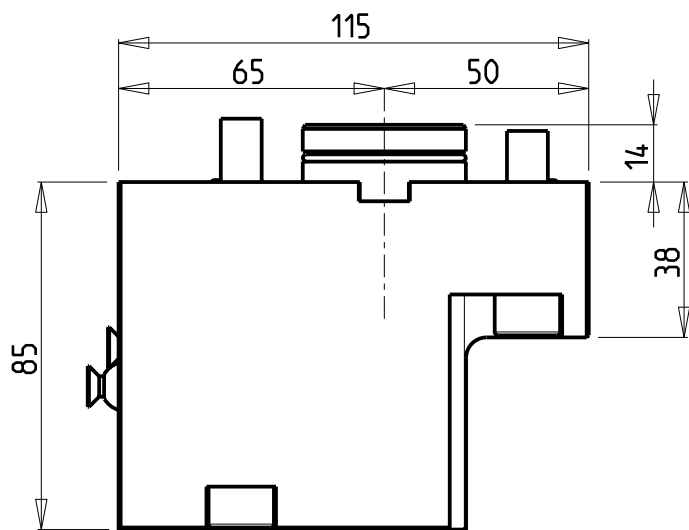
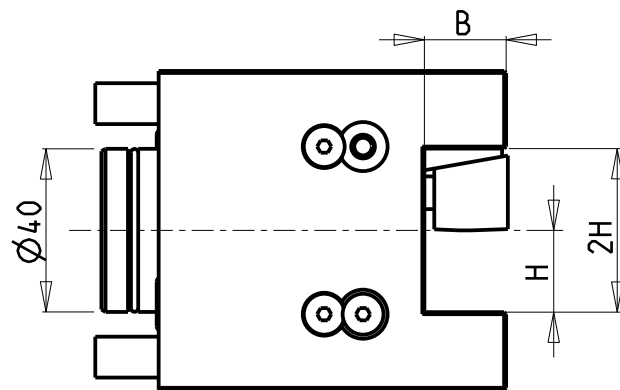
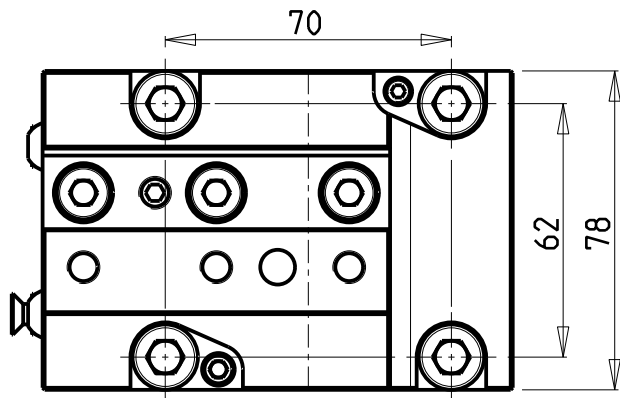

Cod. MT	N°Utensili N°Tools N°Werkzeuge	Reversibile lato mandrino/contromandrino Reversible sub/main spindle side Umkehrbare Spindel-seite/ Gegenspindel-seite	Misure Dimensions Masse	B	H
MNZ0132000	1	X	mm	20	20
MNZ0131905	1	X	Inch	3/4"	3/4"

DMG-MORI

NZ1500/2000 - NZX1500/2000 - NT3000 SERIE - NL1500/2000/2500 20 STAZ. - NLX1500/2000/2500 20 STAZ.
 NT1000/2000 - NTX1000/2000 - NTX1000/2000/2500/3000 2ND GEN. 12ST. - DURATURN 2050MC/2550MC - NRX2000 - ALX1500/2000/2500

PORTAUTENSILE ASSIALE SINGOLO QD=20mm / QD=3/4" H=85mm

Axial single static tool QD=20mm / QD=3/4" H=85mm

Axial Single-Werkzeughalter QD=20mm / QD=3/4" H=85mm

Subject to change without notice.

M.T. srl

Via Casino Albini 480
 Tel. 0541/956034-957884
 Fax 0541/956341
 47842 S. GIOVANNI IN M. (RN)
 e-mail: mtma@mtmarchetti.com
 http://www.mtmarchetti.com

PRODUZIONE MODULI ROTANTI



PAGINA MNZ550-1-00

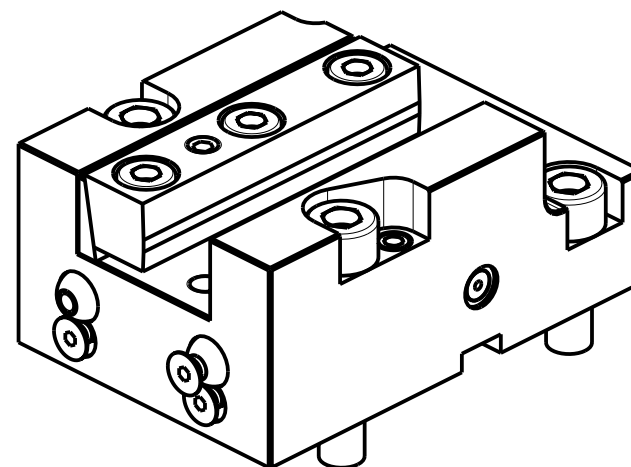
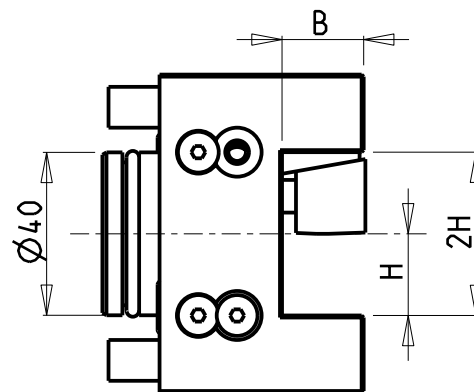
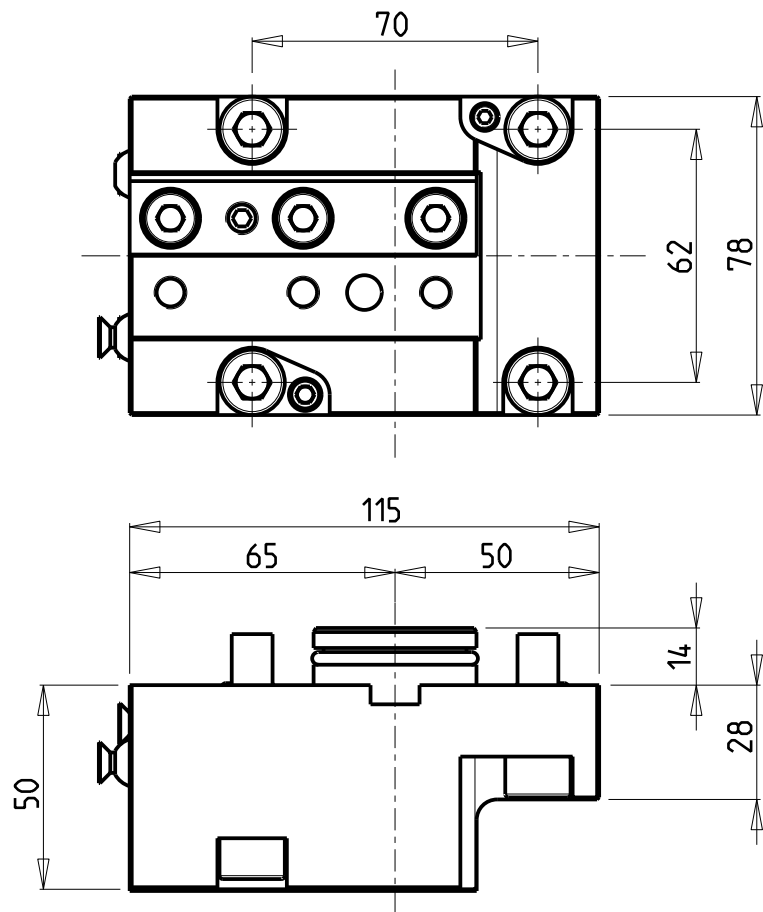

Cod. MT	N°Utensili N°Tools N°Werkzeuge	Reversibile lato mandrino/contromandrino Reversible sub/main spindle side Umkehrbare Spindel-seite/ Gegenspindel-seite	Misure Dimensions Masse	B	H
MNZ0562000	1	X	mm	20	20
MNZ0561905	1	X	Inch	3/4"	3/4"

DMG-MORI

NL1500/2000/2500 20 STAZ. - NLX1500/2000/2500 20 STAZ.
NT1000/2000 - NTX1000/2000 - DURATURN 2050MC/2550MC

PORTAUTENSILE ASSIALE SINGOLO QD=20mm / QD=3/4" H=50mm

Axial single static tool QD=20mm / QD=3/4" H=50mm

Axial Single-Werkzeughalter QD=20mm / QD=3/4" H=50mm

Subject to change without notice.

M.T. srl

Via Casino Albini 480
Tel. 0541/956034-957884
Fax 0541/956341
47842 S. GIOVANNI IN M. (RN)
e-mail: mtma@mtmarchetti.com
http://www.mtmarchetti.com

PRODUZIONE MODULI ROTANTI



PAGINA MNZ550-1-10

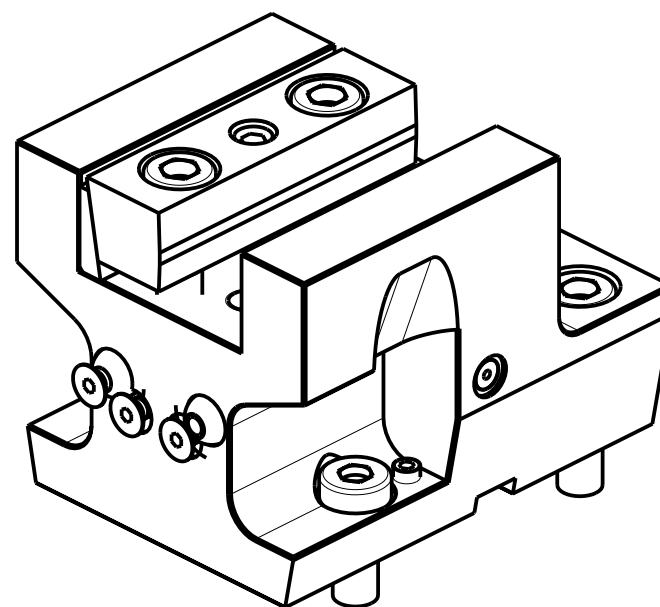
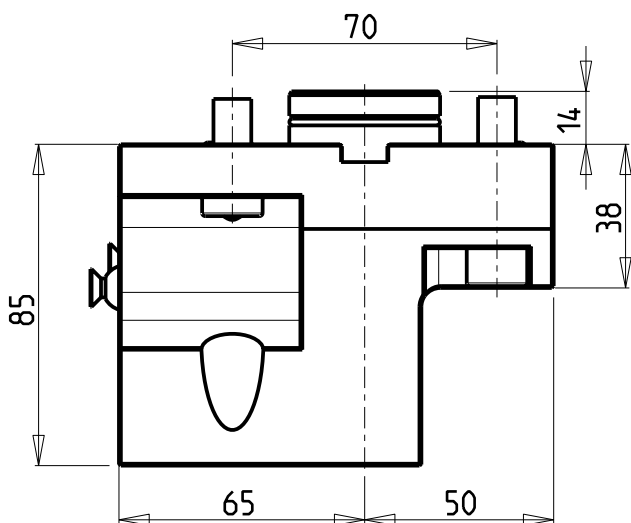
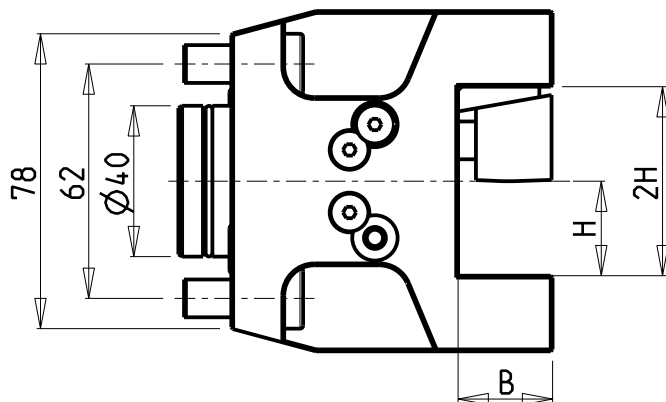
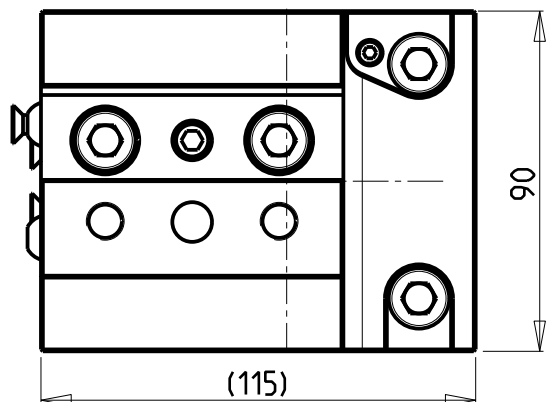

Cod. MT	N°Utensili N° Tools N° Werkzeuge	Reversibile lato mandrino/contromandrino Reversible sub/main spindle side Umkehrbare Spindel-seite/ Gegenspindel-seite	Misure Dimensions Masse	B	H
MNZ0132500	1	X	mm	25	25

DMG-MORI

NZ1500/2000 - NZX1500/2000 - NT3000 SERIE - NL1500/2000/2500 20 STAZ. - NLX1500/2000/2500 20 STAZ.
NT1000/2000 - NTX1000/2000 - NTX1000/2000/2500/3000 2ND GEN. 12ST. - DURATURN 2050MC/2550MC - NRX2000 - ALX1500/2000/2500

PORTAUTENSILE ASSIALE SINGOLO QD=25mm

Axial single static tool QD=25mm

Axial Single-Werkzeughalter QD=25mm

Subject to change without notice.

M.T. srl

Via Casino Albini 480
Tel. 0541/956034-957884
Fax 0541/956341

47842 S. GIOVANNI IN M. (RN)
e-mail: mtma@mtmarchetti.com
http://www.mtmarchetti.com

PRODUZIONE MODULI ROTANTI



PAGINA MNZ552-1-00

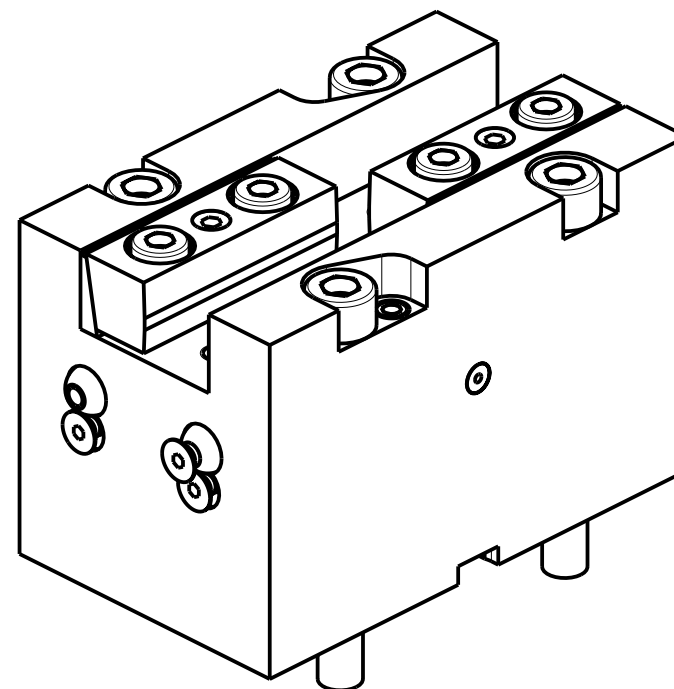
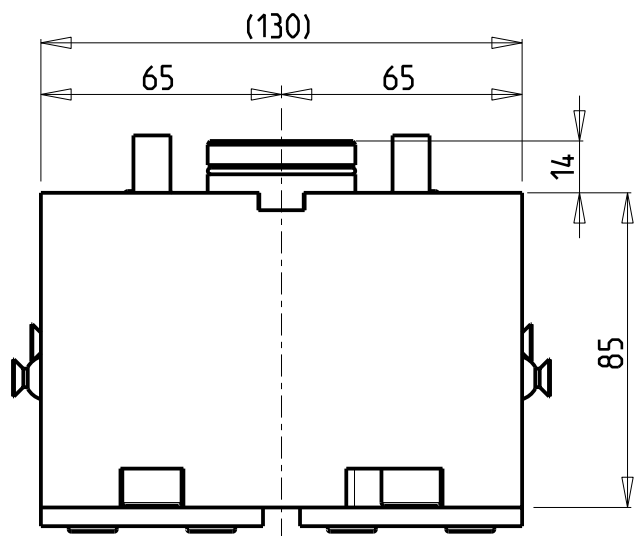
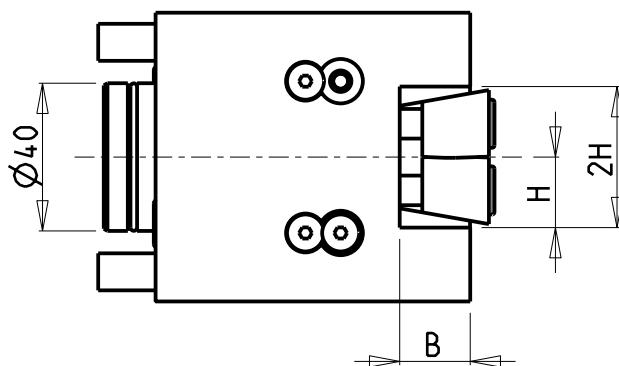
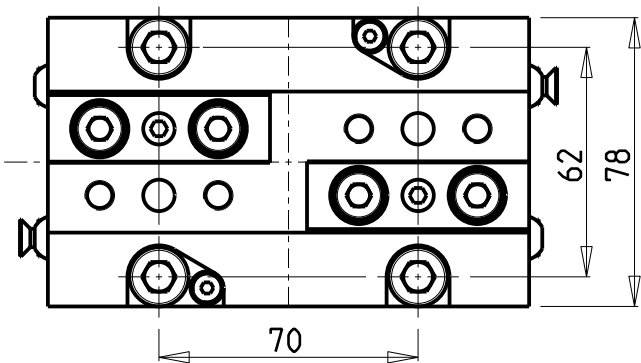

Cod. MT	N°Utensili N° Tools N° Werkzeuge	Reversibile lato mandrino/contromandrino Reversible sub/main spindle side Umkehrbare Spindel-seite/ Gegenspindel-seite	Misure Dimensions Masse	B	H
MNZ0192000	1/2	X	mm	20	20
MNZ0191905	1/2	X	Inch	3/4"	3/4"

DMG-MORI

NZ1500/2000 - NZX1500/2000 - NT3000 SERIE - NL1500/2000/2500 20 STAZ. - NLX1500/2000/2500 20 STAZ.
NT1000/2000 - NTX1000/2000 - DURATURN 2050MC/2550MC - ALX1500/2000/2500

PORTAUTENSILE ASSIALE DOPPIO QD=20mm / QD=3/4"

Axial double static tool QD=20mm / QD=3/4"

Axial Doppel-Werkzeughalter QD=20mm / QD=3/4"

Subject to change without notice.

M.T. srl

Via Casino Albini 480
Tel. 0541/956034-957884
Fax 0541/956341
47842 S. GIOVANNI IN M. (RN)
e-mail: mtma@mtmarchetti.com
<http://www.mtmarchetti.com>

PRODUZIONE MODULI ROTANTI



PAGINA MNZ570-1-00

10/2018

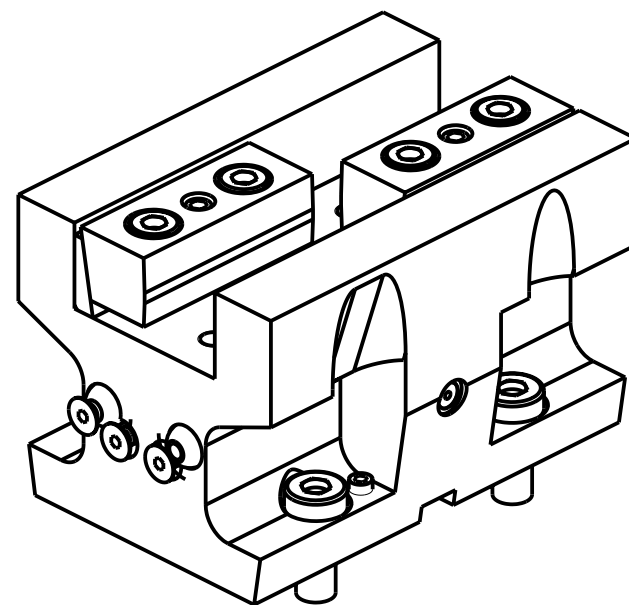
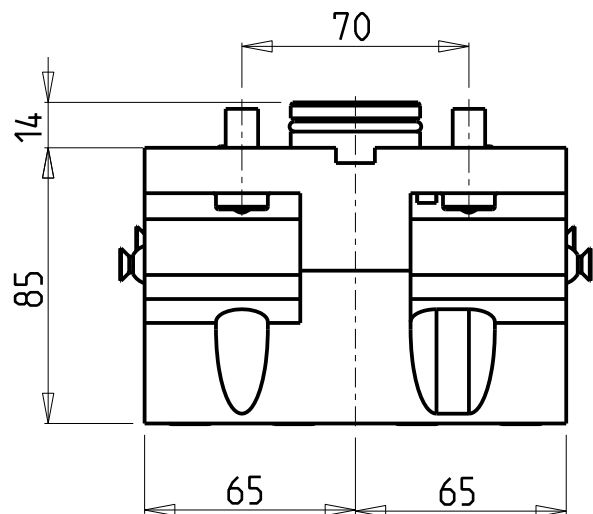
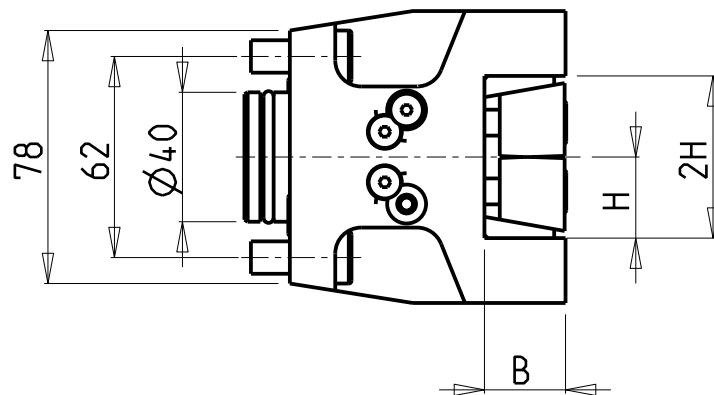
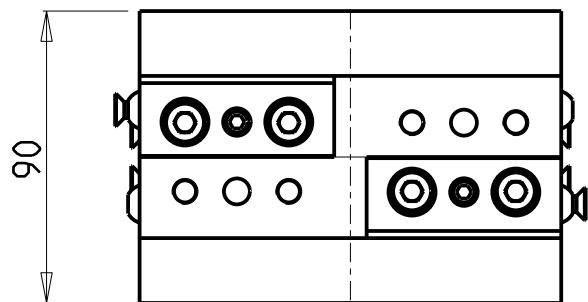

Cod. MT	N°Utensili N° Tools N° Werkzeuge	Reversibile lato mandrino/contromandrino Reversible sub/main spindle side Umkehrbare Spindel-seite/ Gegenspindel-seite	Misure Dimensions Masse	B	H
MNZ0192500	1/2	X	mm	25	25
MNZ0192540	1/2	X	Inch	1"	1"

DMG-MORI

NZ1500/2000 - NZX1500/2000 - NT3000 SERIE - NL1500/2000/2500 20 STAZ. - NLX1500/2000/2500 20 STAZ.
 NT1000/2000 - NTX1000/2000 - DURATURN 2050MC/2550MC - ALX1500/2000/2500

PORTAUTENSILE ASSIALE DOPPIO QD=25mm / QD=1"

Axial double static tool QD=25mm / QD=1"

Axial Doppel-Werkzeughalter QD=25mm / QD=1"

Subject to change without notice.

M.T. srl

Via Casino Albini 480
 Tel. 0541/956034-957884
 Fax 0541/956341
 47842 S. GIOVANNI IN M. (RN)
 e-mail: mtma@mtmarchetti.com
 http://www.mtmarchetti.com

PRODUZIONE MODULI ROTANTI



PAGINA MNZ572-1-00

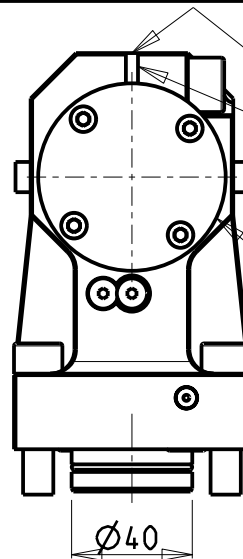
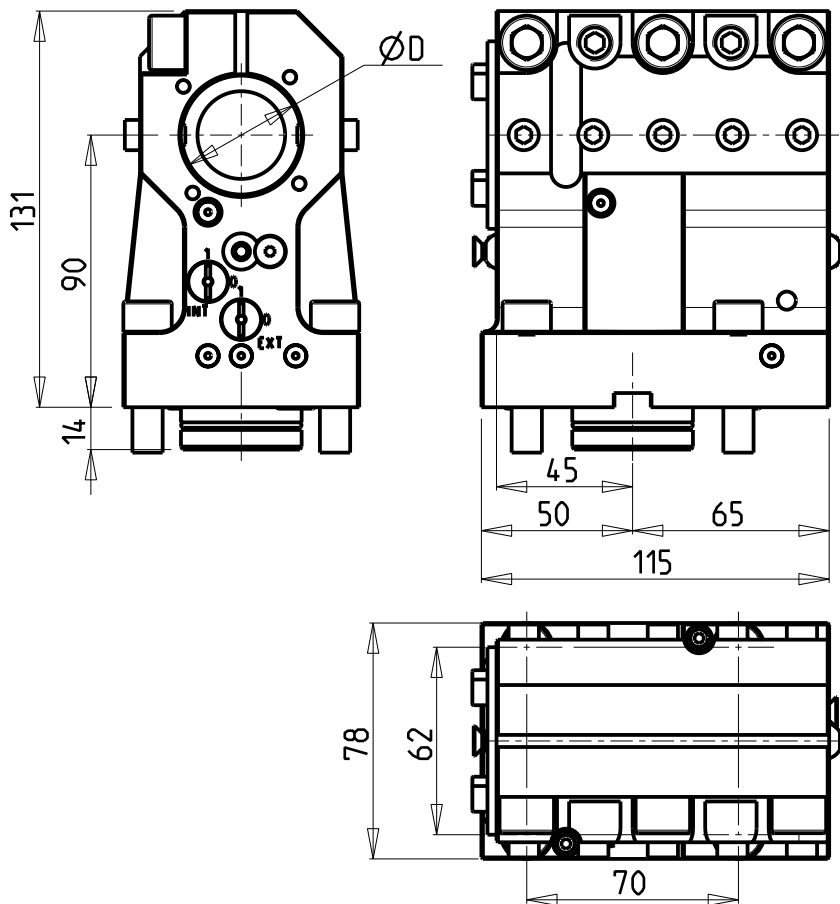

SOLO GUARNIZIONE (OPZIONALE)
 ONLY SEAL (OPTIONAL)
 NUR DICHTUNG (OPTIONAL)
 cod. 0520013

KIT ADDUZIONE INTERNA (OPZIONALE)
 KIT FOR INTERNAL COOLANT (OPTIONAL)
 KIT FUER INTERNE KUEHLMITTELZUFUHR (OPTIONAL)
 Ø40 cod. KIT1003003
 Ø1 1/2" cod. KIT1003004

PER BOCCOLE DI RIDUZIONE VEDI PAG. TBL150-1-00
 FOR REDUCING BUSHINGS SEE PAGE TBL150-1-00
 FUER REDUZIERBUCHSE SIEHE SEITE TBL150-1-00

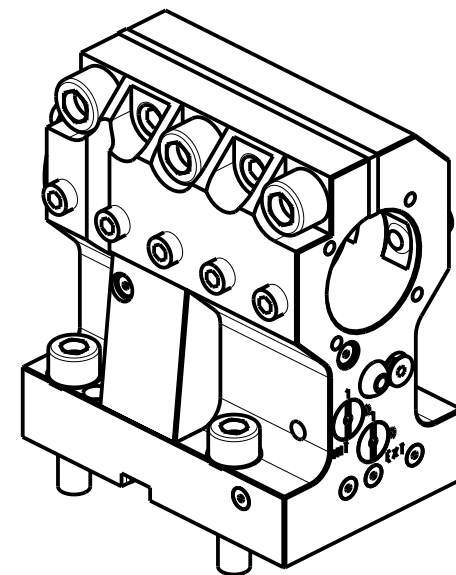

Cod. MT	N°Utensili N°Tools N°Werkzeuge	Lubrificazione int. opzionale Coolant through optional Innenkuehlung Optional	Lubrificazione est. Ext. coolant Aussenkuehlung	Reversibile lato mandrino/contromandrino Reversible sub/main spindle side Umkehrbare Spindel-seite/ Gegenspindel-seite	Misure Dimensions Masse	D
MNZ0154000	1	X	X	X	mm	40
MNZ0153810	1	X	X	X	Inch	1-1/2"

DMG-MORI

NZ1500/2000 - NZX1500/2000 - NT3000 SERIE - NL1500/2000/2500 20 STAZ. - NLX1500/2000/2500 20 STAZ.
 NTX1000/2000/2500/3000 2ND GEN. 12ST. - DURATURN 2050MC/2550MC - ALX1500/2000/2500

PORTAUTENSILE ASSIALE PER BARENO Ø40mm / Ø1 1/2" H=90mm

Axial single boring bar holder Ø40mm / Ø1 1/2" H=90mm

Axial Bohrhalter Ø40mm / Ø1 1/2" H=90mm

Subject to change without notice.

M.T. srl

Via Casino Albini 480
 Tel. 0541/956034-957884
 Fax 0541/956341

47842 S. GIOVANNI IN M. (RN)
 e-mail: mtma@mtmarchetti.com
 http://www.mtmarchetti.com

PRODUZIONE MODULI ROTANTI



PAGINA MNZ630-1-20

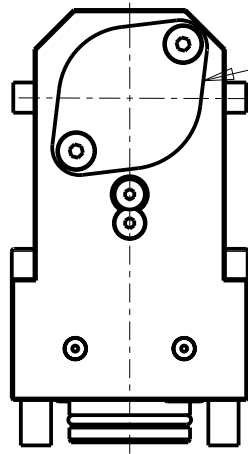
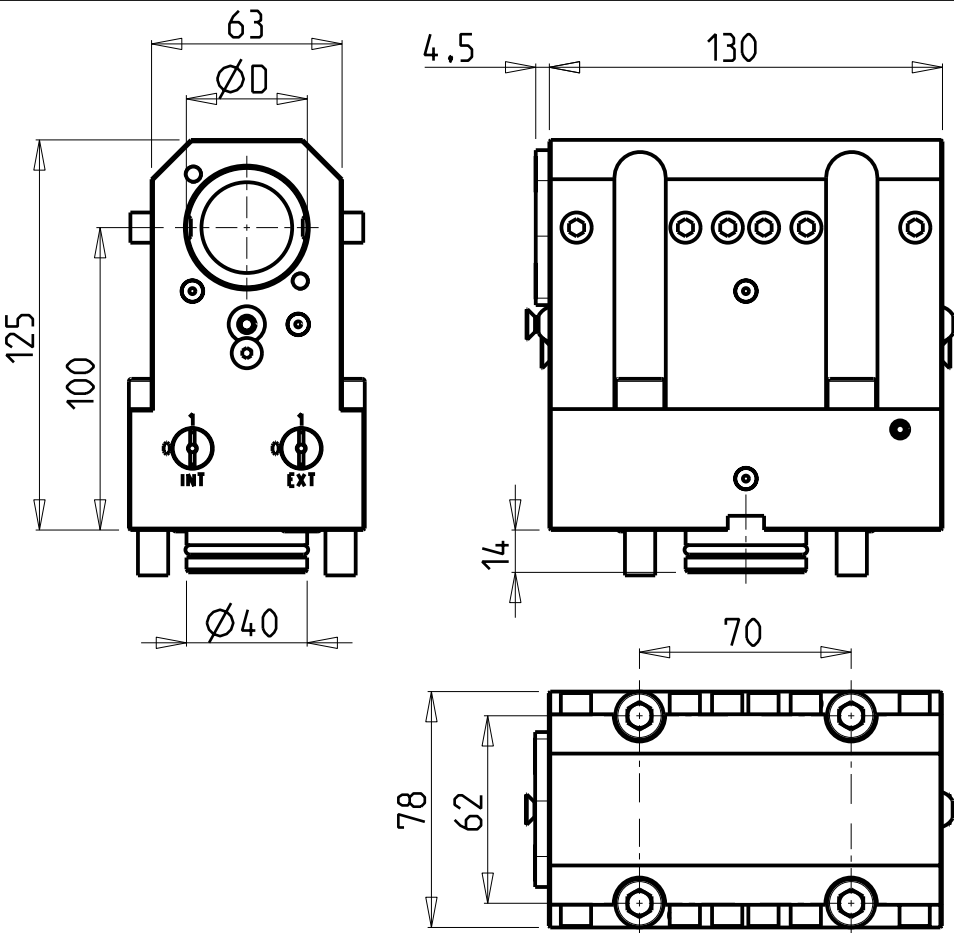

KIT ADDUZIONE INTERNA (OPZIONALE)
 KIT FOR INTERNAL COOLANT (OPTIONAL)
 KIT FUER INTERNE KUEHLMITTELZUFUHR (OPTIONAL)
 Ø40 cod. KIT1000018
 Ø1 1/2" cod. KIT1000021

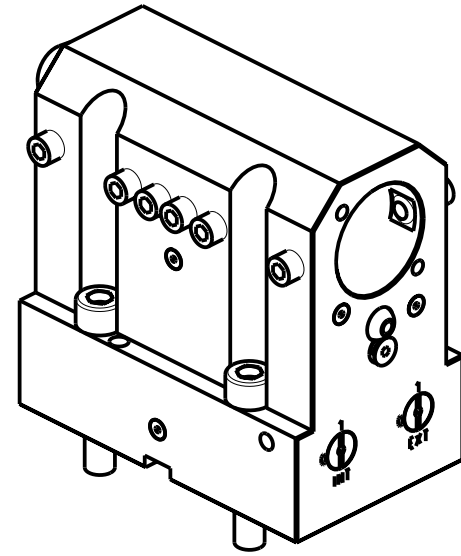

Cod. MT	N°Utensili N°Tools N°Werkzeuge	Reversibile lato mandrino/contromandrino Reversible sub/main spindle side Umkehrbare Spindel-seite/ Gegenspindel-seite	Lubrificazione int. opzionale Coolant through optional Innenkuehlung Optional	Lubrificazione est. Ext. coolant Aussenkuehlung	Misure Dimensions Masse	D
MNZ0144000	1+1	X	X	X	mm	40
MNZ0143810	1+1	X	X	X	inch	1 1/2"

PER BOCCOLE DI RIDUZIONE VEDI PAG. TBL150-1-00
 FOR REDUCING BUSHINGS SEE PAGE TBL150-1-00
 FUER REDUZIERBUCHSE SIEHE SEITE TBL150-1-00

DMG-MORI
 NZ1500/2000 - NZX1500/2000 - NT3000 SERIE - NL1500/2000/2500 20 STAZ. - NLX1500/2000/2500 20 STAZ.
 NT1000/2000 - NTX1000/2000 - NTX1000/2000/2500/3000 2ND GEN. 12ST. - DURATURN 2050MC/2550MC - NRX2000 - ALX1500/2000/2500

PORTAUTENSILE ASSIALE PER BARENO Ø40mm H=100mm
 Axial single boring bar holder Ø40mm H=100mm
 Axial Bohrhälter Ø40mm H=100mm

Subject to change without notice.

M.T. srl
 Via Casino Albini 480
 Tel. 0541/956034-957884
 Fax 0541/956341
 47842 S. GIOVANNI IN M. (RN)
 e-mail: mtma@mtmarchetti.com
 http://www.mtmarchetti.com

PRODUZIONE MODULI ROTANTI



PAGINA MNZ640-1-10

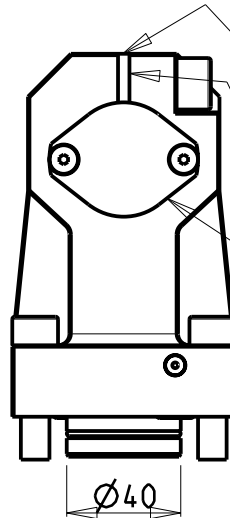
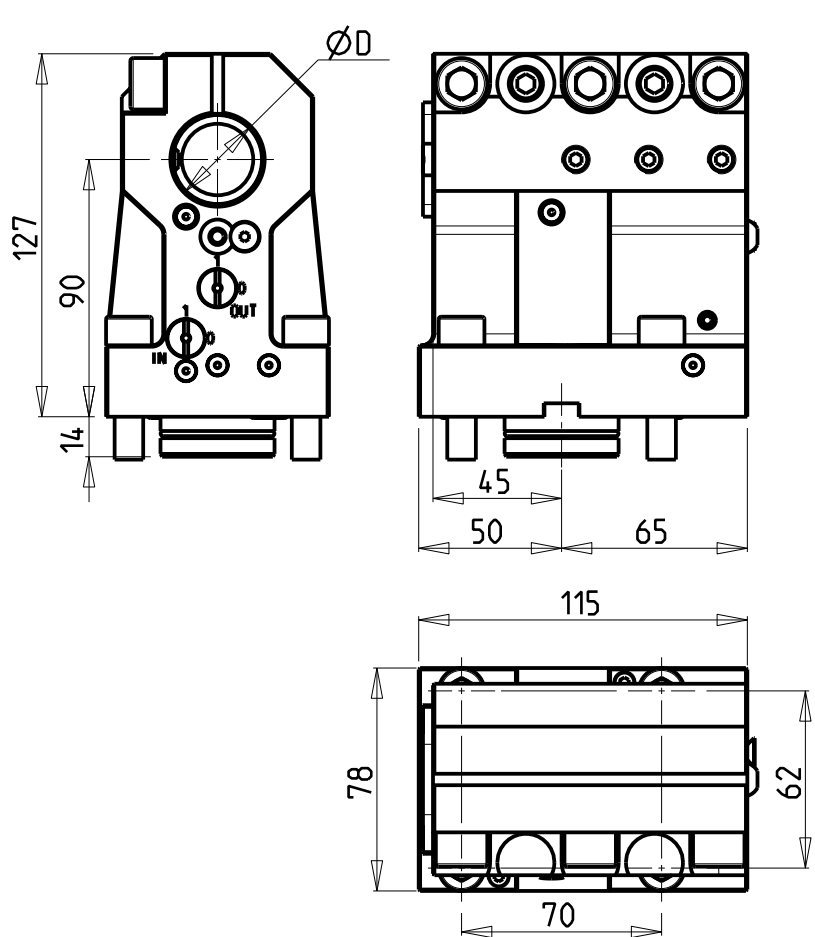

SOLO GUARNIZIONE (OPZIONALE)
 ONLY SEAL (OPTIONAL)
 NUR DICHTUNG (OPTIONAL)
 cod. 0520013

KIT ADDUZIONE INTERNA (OPZIONALE)
 KIT FOR INTERNAL COOLANT (OPTIONAL)
 KIT FUER INTERNE KUEHLMITTELZUFUHR (OPTIONAL)
 Ø32 - Ø1 1/4" cod. KIT1003001

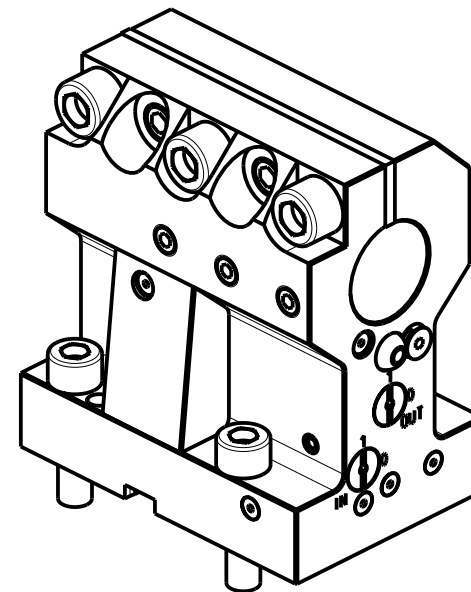

PER BOCCOLE DI RIDUZIONE VEDI PAG. TBL150-1-00
 FOR REDUCING BUSHINGS SEE PAGE TBL150-1-00
 FUER REDUZIERBUCHSE SIEHE SEITE TBL150-1-00

Cod. MT	N°Utensili N°Tools N°Werkzeuge	Lubrificazione int. opzionale Coolant through optional Innenkuehlung Optional	Lubrificazione est. Ext. coolant Aussenkuehlung	Reversibile lato mandrino/contromandrino Reversible sub/main spindle side Umkehrbare Spindel-seite/ Gegenspindel-seite	Misure Dimensions Masse	D
MNZ0153200	1	X	X	X	mm	32
MNZ0153175	1	X	X	X	Inch	1 1/4"

DMG-MORI

NZ1500/2000 - NZX1500/2000 - NT3000 SERIE - NL1500/2000/2500 20 STAZ. - NLX1500/2000/2500 20 STAZ.
 NTX1000/2000/2500/3000 2ND GEN. 12ST. - DURATURN 2050MC/2550MC - ALX1500/2000/2500

PORTAUTENSILE ASSIALE PER BARENO Ø32mm / Ø1 1/4" H=90mm

Axial single boring bar holder Ø32mm / Ø1 1/4" H=90mm

Axial Bohrhalter Ø32mm / Ø1 1/4" H=90mm

Subject to change without notice.

M.T. srl

Via Casino Albini 480
 Tel. 0541/956034-957884
 Fax 0541/956341

47842 S. GIOVANNI IN M. (RN)
 e-mail: mtma@mtmarchetti.com
 http://www.mtmarchetti.com

PRODUZIONE MODULI ROTANTI



PAGINA MNZ650-1-20

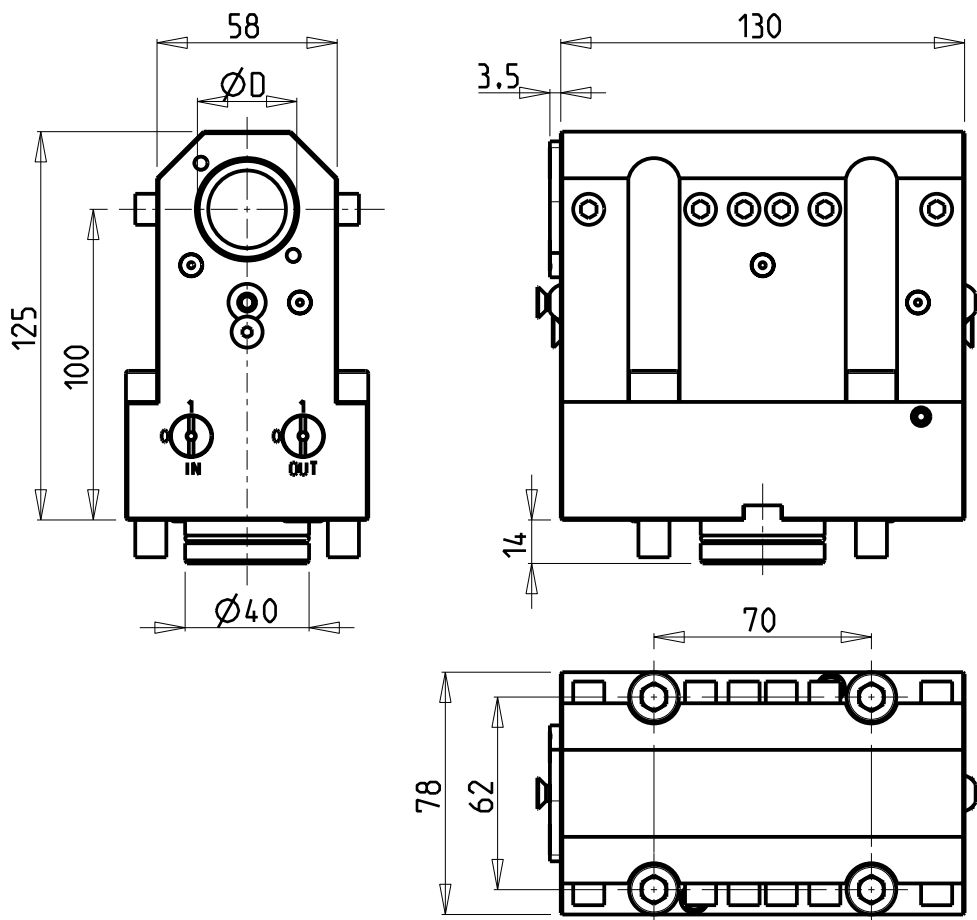

KIT ADDUZIONE INTERNA (OPZIONALE)
 KIT FOR INTERNAL COOLANT (OPTIONAL)
 KIT FUER INTERNE KUEHLMITTELZUFUHR (OPTIONAL)
 Ø32 - Ø1 1/4" cod. KIT1000001

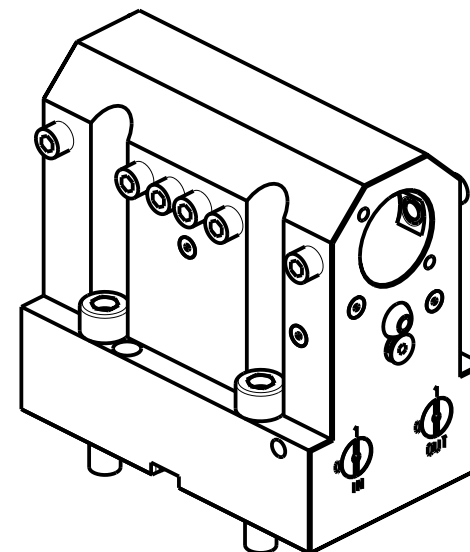
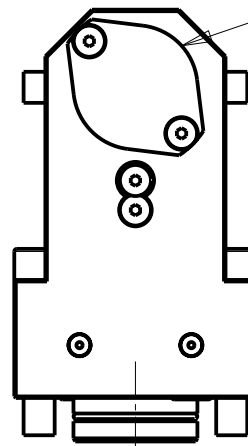

PER BOCCOLE DI RIDUZIONE VEDI PAG. TBL150-1-00
 FOR REDUCING BUSHINGS SEE PAGE TBL150-1-00
 FUER REDUZIERBUCHSE SIEHE SEITE TBL150-1-00

Cod. MT	N°Utensili N° Tools N° Werkzeuge	Reversibile lato mandrino/contromandrino Reversible sub/main spindle side Umkehrbare Spindel-seite/ Gegenspindel-seite	Lubrificazione int. opzionale Coolant through optional Innenkuehlung Optional	Lubrificazione est. Ext. coolant Aussenkuehlung	Misure Dimensions Masse	D
MNZ0143200	1+1	X	X	X	mm	32
MNZ0143175	1+1	X	X	X	Inch	1 1/4"

DMG-MORI

NZ1500/2000 - NZX1500/2000 - NT3000 SERIE - NL1500/2000/2500 20 STAZ. - NLX1500/2000/2500 20 STAZ.
 NT1000/2000 - NTX1000/2000 - NTX1000/2000/2500/3000 2ND GEN. 12ST. - DURATURN 2050MC/2550MC - NRX2000 - ALX1500/2000/2500

PORTAUTENSILE ASSIALE PER BARENO Ø32mm / Ø1 1/4" H=100mm

Axial single boring bar holder Ø32mm / Ø1 1/4" H=100mm

Axial Bohrhalter Ø32mm / Ø1 1/4" H=100mm

Subject to change without notice.

M.T. srl

Via Casino Albini 480
 Tel. 0541/956034-957884
 Fax 0541/956341

47842 S. GIOVANNI IN M. (RN)
 e-mail: mtma@mtmarchetti.com
 http://www.mtmarchetti.com

PRODUZIONE MODULI ROTANTI



PAGINA MNZ660-1-10

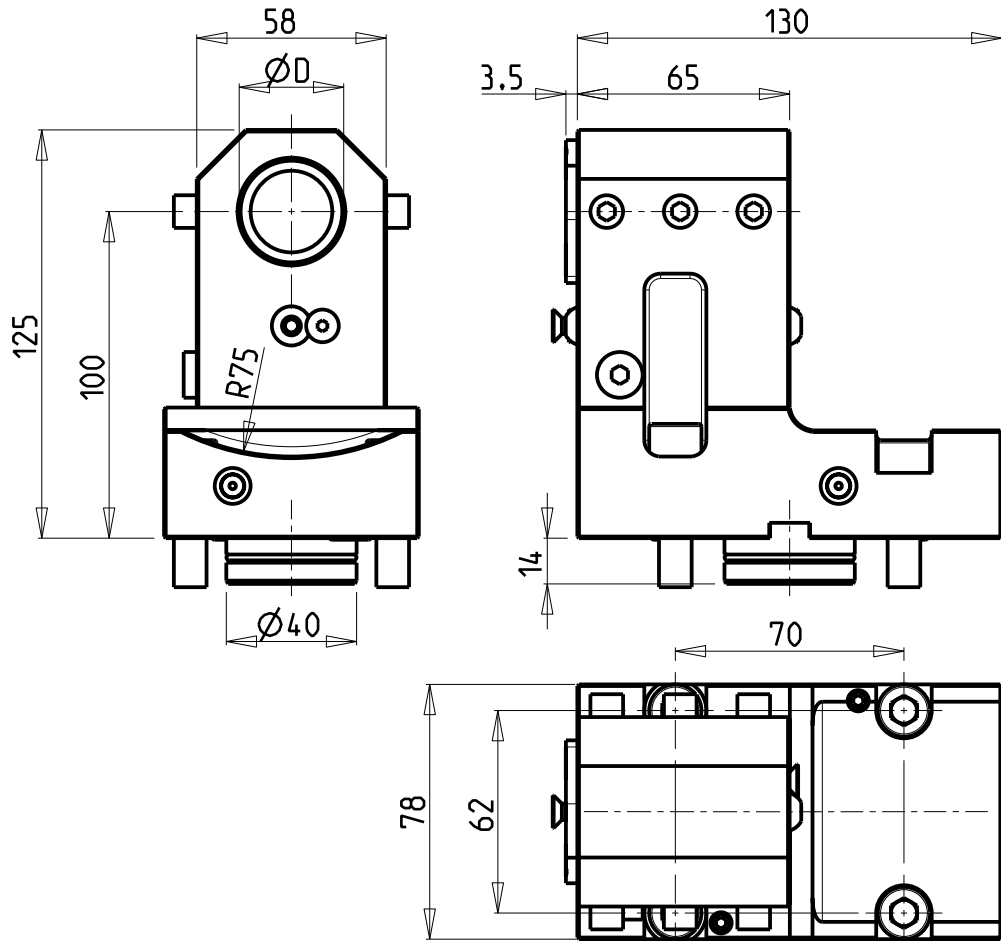

KIT ADDUZIONE INTERNA (OPZIONALE)
 KIT FOR INTERNAL COOLANT (OPTIONAL)
 KIT FUER INTERNE KUEHLMITTELZUFUHR (OPTIONAL)
 Ø32 / Ø1 1/4" cod. KIT1000001

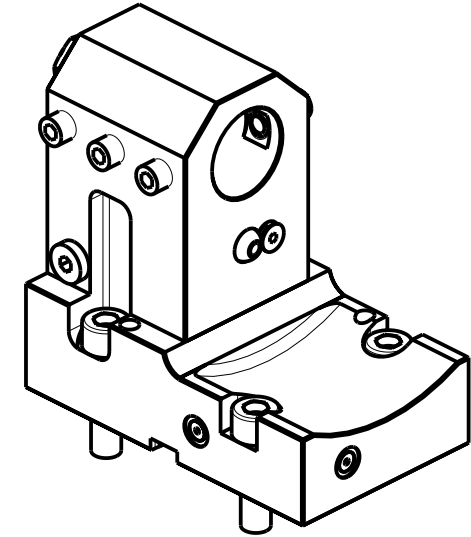
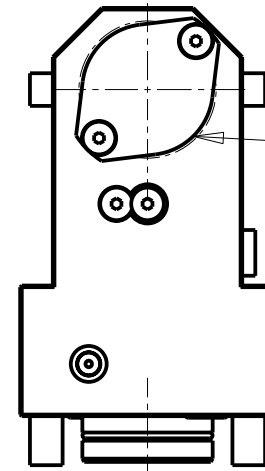

PER BOCCOLE DI RIDUZIONE VEDI PAG. TBL150-1-00
 FOR REDUCING BUSHINGS SEE PAGE TBL150-1-00
 FUER REDUZIERBUCHSE SIEHE SEITE TBL150-1-00

Cod. MT	Reversibile lato mandrino/contromandrino Reversible sub/main spindle side Umkehrbare Spindelsete/Gegenspindelsete	Lubrificazione int. opzionale Coolant through optional Innenkuehlung Optional	Lubrificazione est. Ext. coolant Aussenkuehlung	Misure Dimensions Masse	D
MNZ0223200	X	X	X	mm	32
MNZ0223175	X	X	X	inch	1 1/4"

DMG-MORI

NZ1500/2000 - NZX1500/2000 - NT3000 SERIE - NL1500/2000/2500 20 STAZ. - NLX1500/2000/2500 20 STAZ.
 NT1000/2000 - NTX1000/2000 - NTX1000/2000/2500/3000 2ND GEN. 12ST. - DURATURN 2050MC/2550MC - NRX2000 - ALX1500/2000/2500

PORTAUTENSILE ASSIALE ARRETRATO PER BARENO Ø32mm H=100mm

Axial single rear set boring bar holder Ø32mm H=100mm

Axial Bohrhalter zurueckversetzt Ø32mm H=100mm

Subject to change without notice.

M.T. srl

Via Casino Albini 480
 Tel. 0541/956034-957884
 Fax 0541/956341

47842 S. GIOVANNI IN M. (RN)
 e-mail: mtma@mtmarchetti.com
 http://www.mtmarchetti.com

PRODUZIONE MODULI ROTANTI



PAGINA MNZ845-1-10

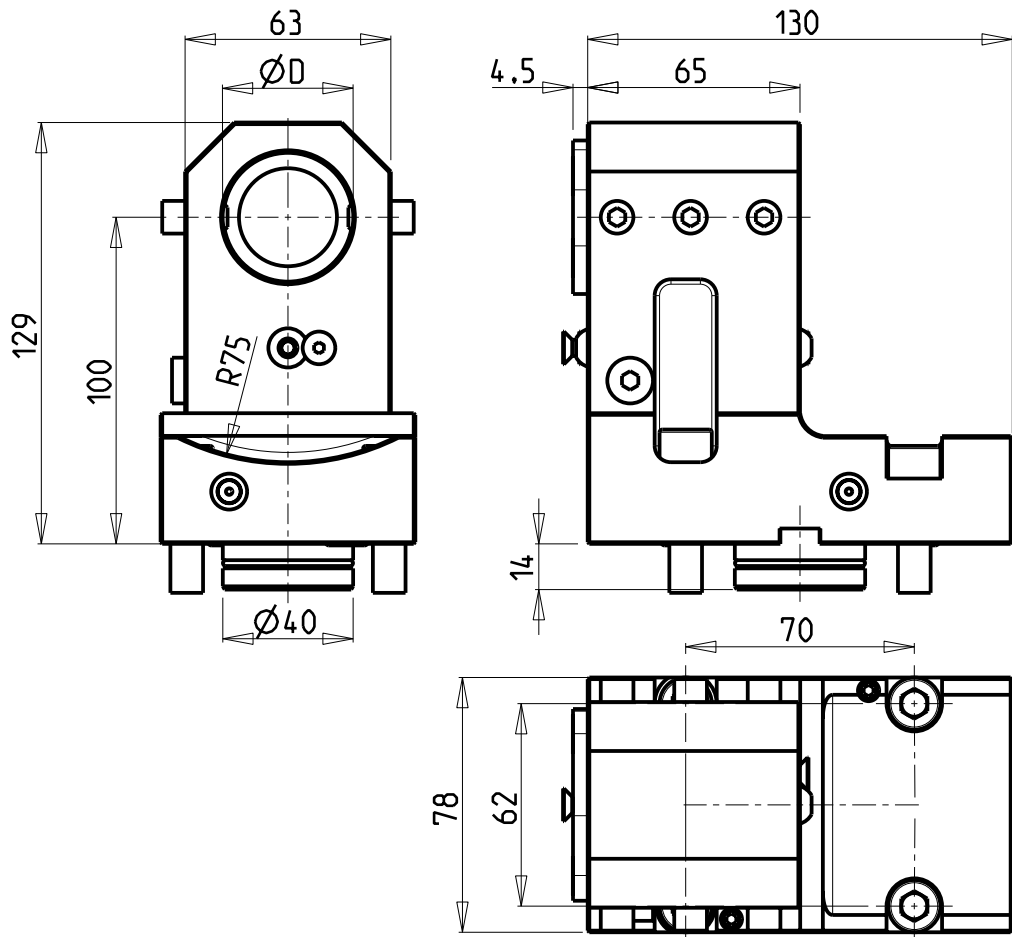

KIT ADDUZIONE INTERNA (OPZIONALE)
 KIT FOR INTERNAL COOLANT (OPTIONAL)
 KIT FUER INTERNE KUEHLMITTELZUFUHR (OPTIONAL)
 Ø40 cod. KIT1000018
 Ø1 1/2" cod. KIT1000021

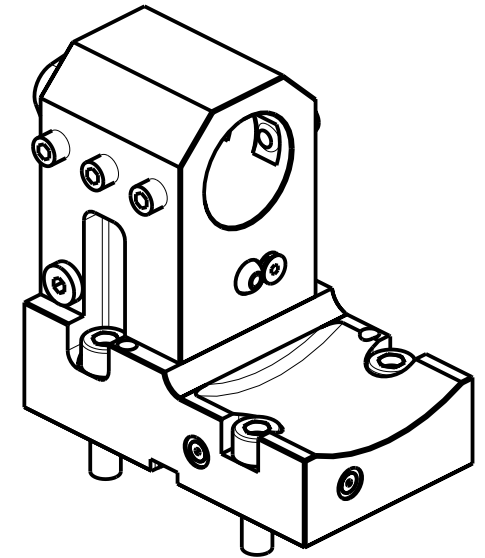
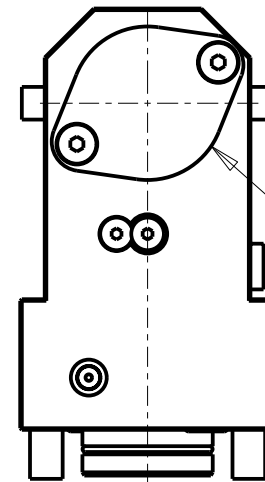

PER BOCCOLE DI RIDUZIONE VEDI PAG. TBL150-1-00
 FOR REDUCING BUSHINGS SEE PAGE TBL150-1-00
 FUER REDUZIERBUCHSE SIEHE SEITE TBL150-1-00

Cod. MT	Reversibile lato mandrino/contromandrino Reversible sub/main spindle side Umkehrbare Spindel-seite/ Gegenspindel-seite	Lubrificazione int. opzionale Coolant through optional Innenkuehlung Optional	Lubrificazione est. Ext. coolant Aussenkuehlung	Misure Dimensions Masse	D
MNZ0224000	X	X	X	mm	40
MNZ0223810	X	X	X	inch	1 1/2"

DMG-MORI

NZ1500/2000 - NZX1500/2000 - NT3000 SERIE - NL1500/2000/2500 20 STAZ. - NLX1500/2000/2500 20 STAZ.
 NTX1000/2000/2500/3000 2ND GEN. 12ST. - DURATURN 2050MC/2550MC - ALX1500/2000/2500

PORTAUTENSILE ASSIALE ARRETRATO PER BARENO Ø40mm H=100mm

Axial single rear set boring bar holder Ø40mm H=100mm

Axial Bohrhälter zurueckversetzt Ø40mm H=100mm

Subject to change without notice.

M.T. srl

Via Casino Albini 480
 Tel. 0541/956034-957884
 Fax 0541/956341

47842 S. GIOVANNI IN M. (RN)
 e-mail: mtma@mtmarchetti.com
 http://www.mtmarchetti.com

PRODUZIONE MODULI ROTANTI



PAGINA MNZ845-1-20

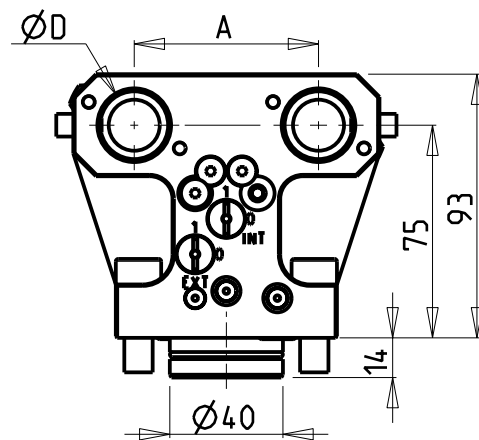
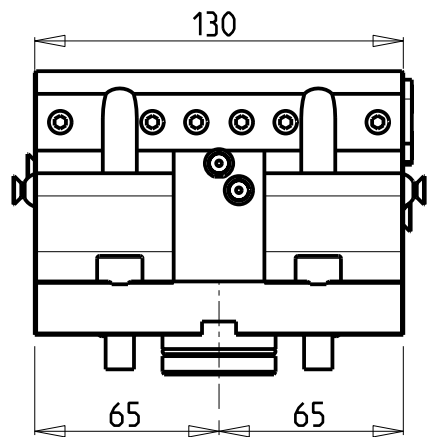
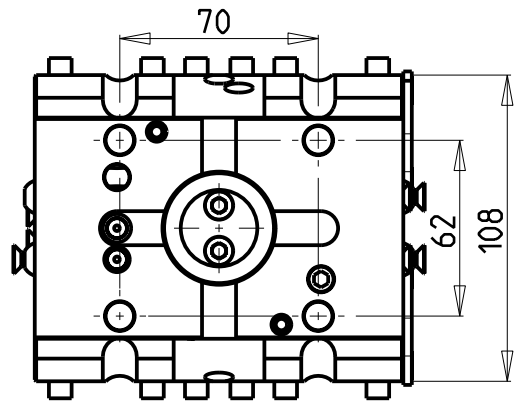

KIT ADDUZIONE INTERNA (OPZIONALE)
 KIT FOR INTERNAL COOLANT (OPTIONAL)
 KIT FUER INTERNE KUEHLMITTELZUFUHR (OPTIONAL)
 Ø25 / Ø1" cod. KIT1000006
 Ø20 cod. KIT1000015
 Ø3/4" cod. KIT1000005

PER BOCCOLE DI RIDUZIONE VEDI PAG. TBL150-1-00
 FOR REDUCING BUSHINGS SEE PAGE TBL150-1-00
 FUR REDUZIERBUCHSE SIEHE SEITE TBL150-1-00

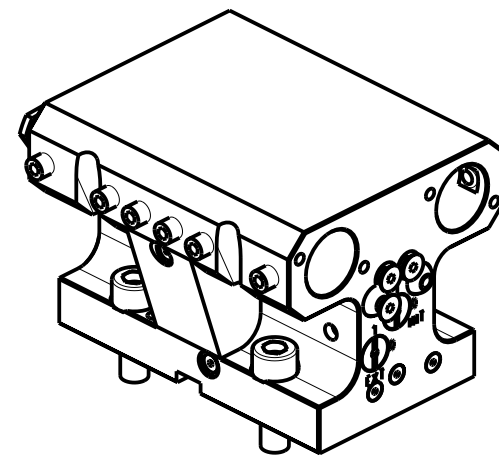
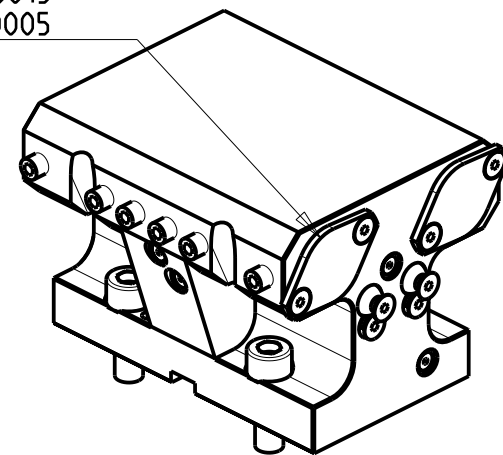

Cod. MT	N°Utensili N°Tools N°Werkzeuge	Reversibile lato mandrino/contromandrino Reversible sub/main spindle side Umkehrbare Spindel-seite/ Gegenspindel-seite	Lubrificazione int. opzionale Coolant through optional Innenkuehlung Optional	Lubrificazione est. Ext. coolant Aussenkuehlung	Misure Dimensions Masse	D	A
MNZ0242500	2+2	X	X	X	mm	25	65
MNZ0242540	2+2	X	X	X	Inch	1"	63.5
MNZ0242000	2+2	X	X	X	mm	20	65
MNZ0241905	2+2	X	X	X	Inch	3/4"	63.5

DMG-MORI

NZ1500/2000 - NZX1500/2000 - NT3000 SERIE - NL1500/2000/2500 20 STAZ. - NLX1500/2000/2500 20 STAZ.
 NT1000/2000 - NTX1000/2000 - NTX1000/2000/2500/3000 2ND GEN. 12ST. - DURATURN 2050MC/2550MC - ALX1500/2000/2500

PORTAUTENSILE ASSIALE PER BARENO 2+2 POSIZIONI Ø25mm / Ø1" / Ø20mm / Ø3/4"

Axial 2+2 position boring bar holder Ø25mm / Ø1" / Ø20mm / Ø3/4"

Axial Bohrhalter 2+2 Positionen Ø25mm / Ø1" / Ø20mm / Ø3/4"

Subject to change without notice.

M.T. srl

Via Casino Albini 480
 Tel. 0541/956034-957884
 Fax 0541/956341
 47842 S. GIOVANNI IN M. (RN)
 e-mail: mtma@mtmarchetti.com
 http://www.mtmarchetti.com

PRODUZIONE MODULI ROTANTI



PAGINA MNZ864-1-00

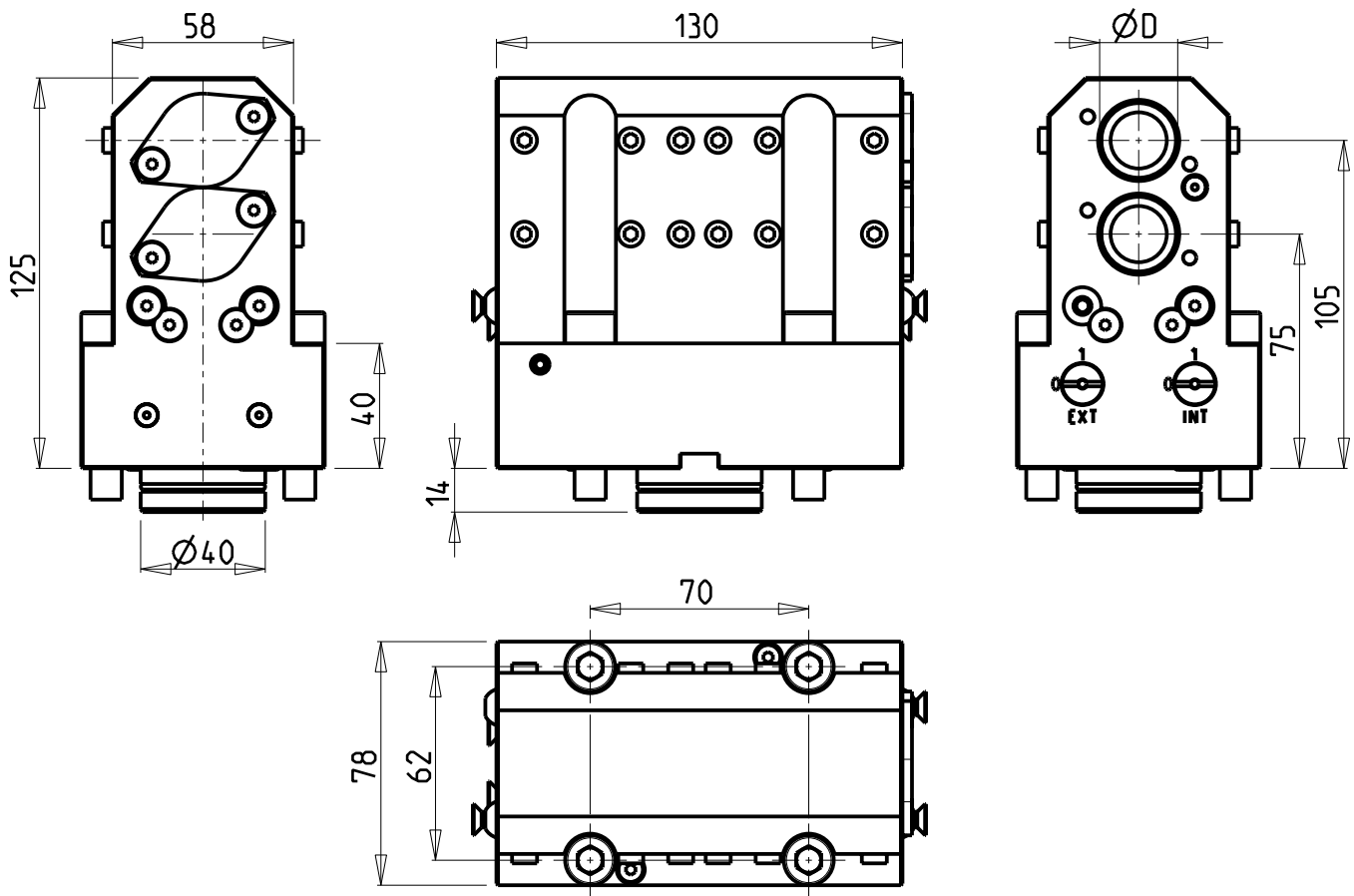

KIT ADDUZIONE INTERNA (OPZIONALE)
 KIT FOR INTERNAL COOLANT (OPTIONAL)
 KIT FUER INTERNE KUEHLMITTELZUFUHR (OPTIONAL)
 Ø25 / Ø1" cod. KIT1000006

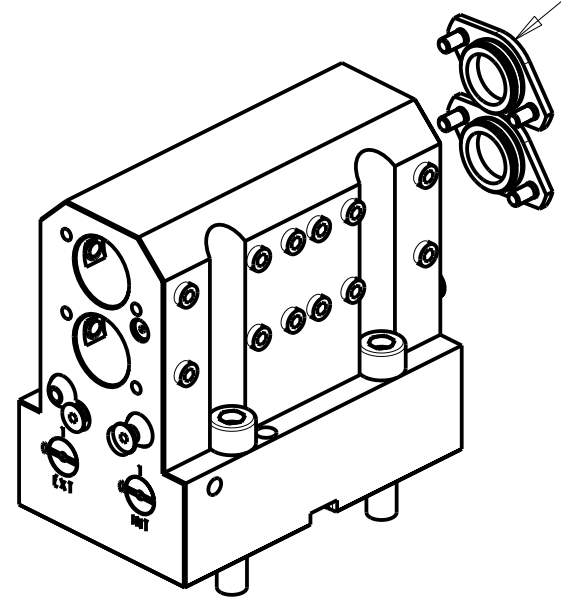

PER BOCCOLE DI RIDUZIONE VEDI PAG. TBL150-1-00
 FOR REDUCING BUSHINGS SEE PAGE TBL150-1-00
 FUER REDUZIERBUCHSE SIEHE SEITE TBL150-1-00

Cod. MT	N°Utensili N°Tools N°Werkzeuge	Reversibile lato mandrino/contromandrino Reversible sub/main spindle side Umkehrbare Spindel-seite/ Gegenspindel-seite	Lubrificazione int. opzionale Coolant through optional Innenkuehlung Optional	Lubrificazione est. Ext. coolant Aussenkuehlung	Misure Dimensions Masse	D
MNZ0162500	2+2	X	X	X	mm	25
MNZ0162540	2+2	X	X	X	Inch	1"

DMG-MORI
 NZ1500/2000 - NZX1500/2000 - NT3000 SERIE - NL1500/2000/2500 20 STAZ. - NLX1500/2000/2500 20 STAZ.
 NT1000/2000 - NTX1000/2000 - NTX1000/2000/2500/3000 2ND GEN. 12ST. - DURATURN 2050MC/2550MC - ALX1500/2000/2500
PORTAUTENSILE ASSIALE PER BARENO 2+2 POSIZIONI Ø25mm / Ø1"
 Axial 2+2 position boring bar holder Ø25mm / Ø1"
 Axial Bohrhälter 2+2 Positionen Ø25mm / Ø1"

M.T. srl
 Via Casino Albini 480
 Tel. 0541/956034-957884
 Fax 0541/956341
 47842 S. GIOVANNI IN M. (RN)
 e-mail: mtma@mtmarchetti.com
 http://www.mtmarchetti.com

PRODUZIONE MODULI ROTANTI

 PAGINA MNZ874-1-00

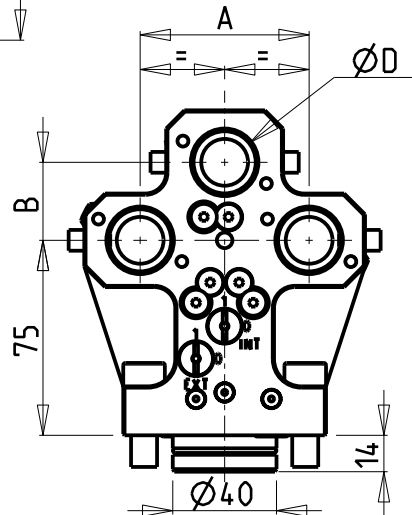
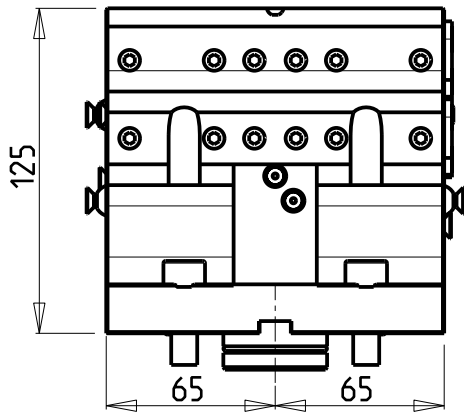
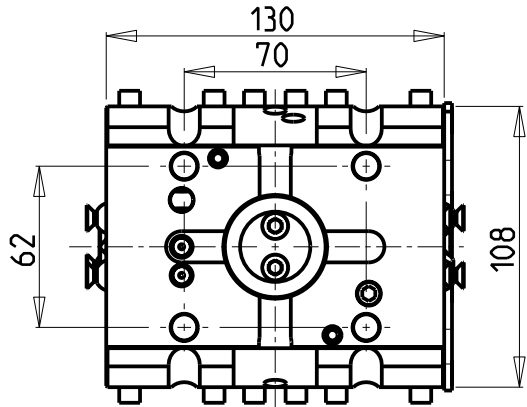
Subject to change without notice.

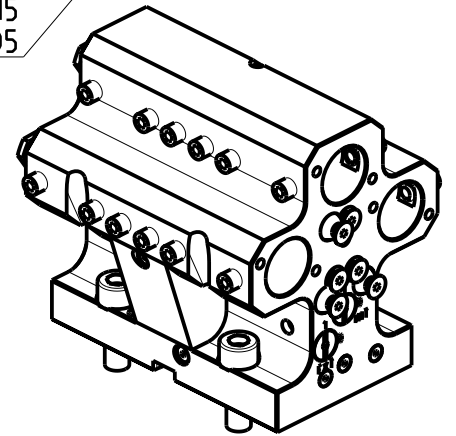
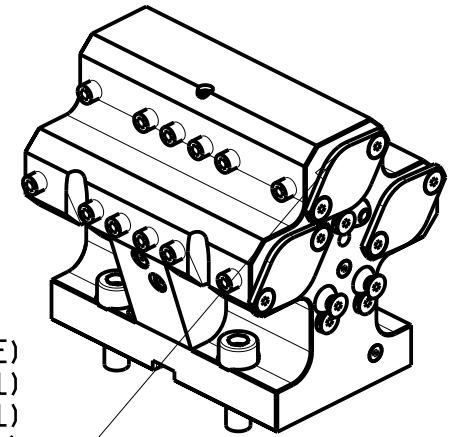

PER BOCCOLE DI RIDUZIONE VEDI PAG. TBL150-1-00
 FOR REDUCING BUSHINGS SEE PAGE TBL150-1-00
 FUER REDUZIERBUCHSE SIEHE SEITE TBL150-1-00

KIT ADDUZIONE INTERNA (OPZIONALE)
 KIT FOR INTERNAL COOLANT (OPTIONAL)
 KIT FUER INTERNE KUEHLMITTELZUFUHR (OPTIONAL)
 Ø25 / Ø1" cod. KIT1000006
 Ø20 cod. KIT1000015
 Ø3/4" cod. KIT1000005



Cod. MT	N°Utensili N°Tools N°Werkzeuge	Reversibile lato mandrino/contromandrino Reversible sub/main spindle side Umkehrbare Spindel-seite/ Gegenspindel-seite	Lubrificazione int. opzionale Coolant through optional Innenkuehlung Optional	Lubrificazione est. Ext. coolant Aussenkuehlung	Misure Dimensions Masse	D	A	B
MNZ0172500	3+3	X	X	X	mm	25	65	30
MNZ0172540	3+3	X	X	X	Inch	1"	63.5	1"1/4
MNZ0172000	3+3	X	X	X	mm	20	65	30
MNZ0171905	3+3	X	X	X	Inch	3/4"	63.5	2"1/2

DMG-MORI

NZ1500/2000 - NZX1500/2000 - NT3000 SERIE - NL1500/2000/2500 20 STAZ. - NLX1500/2000/2500 20 STAZ.
 NT1000/2000 - NTX1000/2000 - NTX1000/2000/2500/3000 2ND GEN. 12ST. - DURATURN 2050MC/2550MC - ALX1500/2000/2500

PORTAUTENSILE ASSIALE PER BARENO 3+3 POSIZIONI Ø25mm / Ø1" / Ø20mm / Ø3/4"

Axial 3+3 position boring bar holder Ø25mm / Ø1" / Ø20mm / Ø3/4"

Axial Bohrhälter 3+3 Positionen Ø25mm / Ø1" / Ø20mm / Ø3/4"

Subject to change without notice.

M.T. srl

Via Casino Albini 480
 Tel. 0541/956034-957884
 Fax 0541/956341
 47842 S. GIOVANNI IN M. (RN)
 e-mail: mtma@mtmarchetti.com
 http://www.mtmarchetti.com

PRODUZIONE MODULI ROTANTI



PAGINA MNZ914-1-00

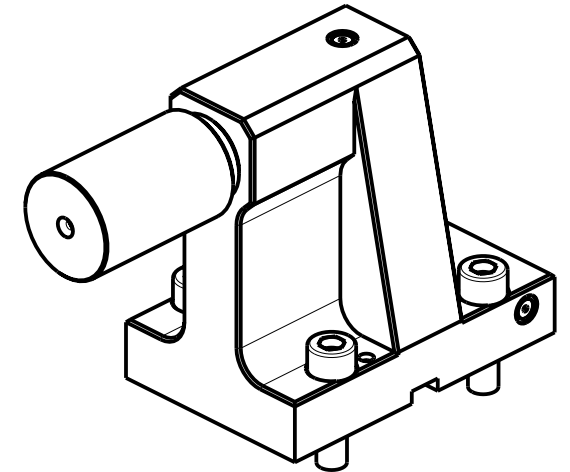
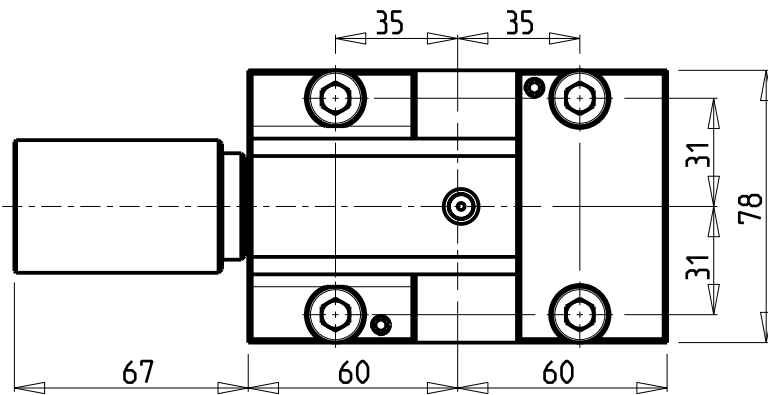
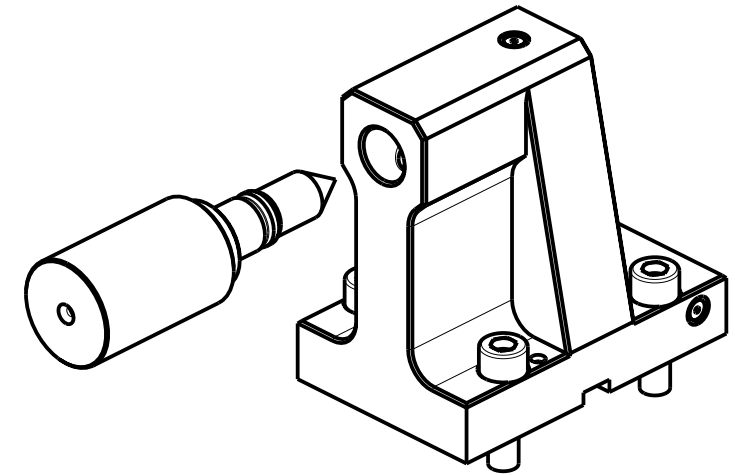
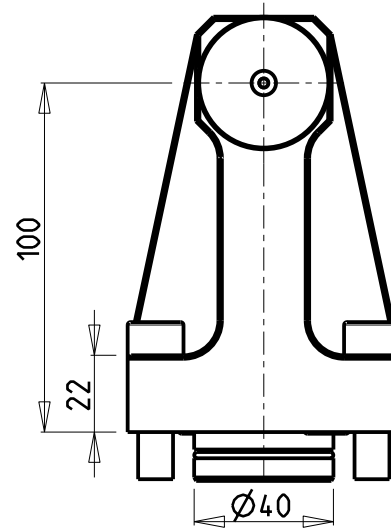
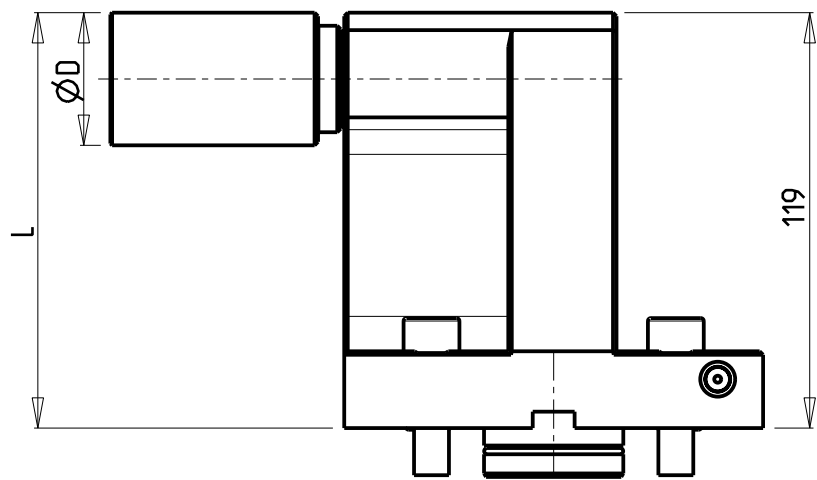

Cod. MT	N° Utensili N° Tools N° Werkzeuge	D	L
MNZ0300100	1	38	119
MNZ0300100L	1	2"	125.4

DMG-MORI

NZ1500/2000 - NZX1500/2000 - NT3000 SERIE - NL1500/2000/2500 20 STAZ. - NLX1500/2000/2500 20 STAZ.
 NT1000/2000 - NTX1000/2000 - NTX1000/2000/2500/3000 2ND GEN. 12ST. - DURATURN 2050MC/2550MC - ALX1500/2000/2500

CONTROPUNTA PER CONTROMANDRINO

Tailstock for subspindle

Gegenspintz fuer Gegenspindel

Subject to change without notice.

M.T. srl

Via Casino Albini 480
 Tel. 0541/956034-957884
 Fax 0541/956341
 47842 S. GIOVANNI IN M. (RN)
 e-mail: mtma@mtmarchetti.com
<http://www.mtmarchetti.com>

PRODUZIONE MODULI ROTANTI



PAGINA MNZ950-1-00

