

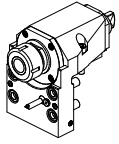

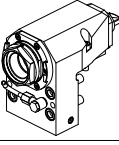

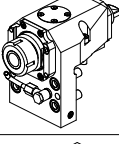

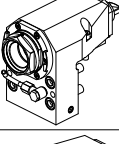
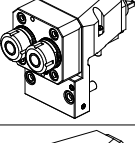
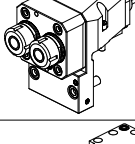

		PAGINA Page Seite
MODULO MOTORIZZATO RADIALE Radial driven tool Radial angetriebenes Werkzeug		CMZ010.2.00
MODULO MOTORIZZATO RADIALE MTSK Radial MTSK driven tool Radial MTSK angetriebenes Werkzeug		CMZ010.2.00.K
MODULO MOTORIZZATO RADIALE 12000 RPM Radial driven tool 12000 rpm Radial angetriebenes Werkzeug 12000 rpm		CMZ010.2.01
MODULO MOTORIZZATO RADIALE MTSK 12000 RPM Radial MTSK driven tool 12000 rpm Radial MTSK angetriebenes Werkzeug 12000 rpm		CMZ010.2.01.K
MODULO MOTORIZZATO RADIALE 2 USCITE IN Y Radial single side twin head driven tool in Y Radial angetriebenes Werkzeug 2 Ausgaenge in Y		CMZ080.2.00
MODULO MOTORIZZATO RADIALE 2 USCITE IN Y 12000 RPM Radial single side twin head driven tool in Y 12000 rpm Radial angetriebenes Werkzeug 2 Ausgaenge in Y 12000 rpm		CMZ080.2.01 
MODULO MOTORIZZATO SPECIALE RADIALE DISASSATO IN Z 376mm Radial special driven tool re-directed in Z by 376mm Radial spezial angetriebenes Werkzeug achsversetzt in Z um 376mm		CMZ125.2.10
MODULO MOTORIZZATO SPECIALE RADIALE IN Y Radial special driven tool in Y Radial spezial angetriebenes Werkzeug in Y		CMZ130.2.00
MODULO MOTORIZZATO ASSIALE H=55mm Axial driven tool H=55mm Axial angetriebenes Werkzeug H=55mm		CMZ150.2.10
MODULO MOTORIZZATO ASSIALE MTSK H=55mm Axial MTSK driven tool H=55mm Axial MTSK angetriebenes Werkzeug H=55mm		CMZ150.2.10.K
MODULO MOTORIZZATO ASSIALE H=55mm 12000 RPM Axial driven tool H=55mm 12000 rpm Axial angetriebenes Werkzeug H=55mm 12000 rpm		CMZ150.2.11
MODULO MOTORIZZATO ASSIALE MTSK H=55mm 12000 RPM Axial MTSK driven tool H=55mm 12000 rpm Axial MTSK angetriebenes Werkzeug H=55mm 12000 rpm		CMZ150.2.11.K

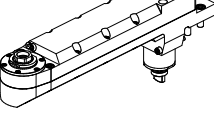
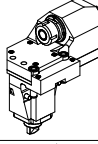
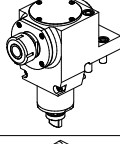
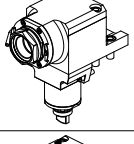
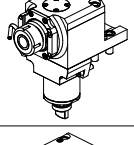
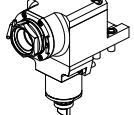
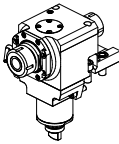
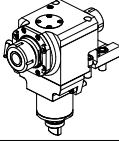
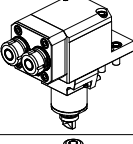
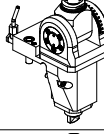
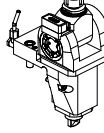
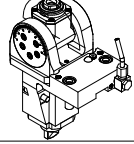
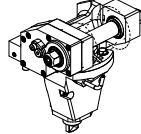
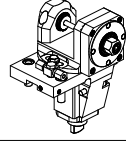
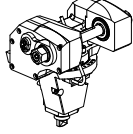
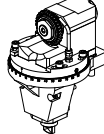
		PAGINA Page Seite
MODULO MOTORIZZATO ASSIALE BISPORGENTE Axial opposite face twin driven tool Axial angetriebenes Werkzeug halb vorspringend		CMZ240.2.10
MODULO MOTORIZZATO ASSIALE BISPORGENTE 12000 RPM Axial opposite face twin driven tool 12000 rpm Axial angetriebenes Werkzeug halb vorspringend 12000 rpm		CMZ240.2.11
MODULO MOTORIZZATO ASSIALE 2 USCITE IN Y Axial single side twin head driven tool in Y Axial angetriebenes Werkzeug 2 Ausgaenge in Y		CMZ260.2.10
MODULO MOTORIZZATO ORIENTABILE ±90° ±90° adjustable angle driven tool Angetriebenes Werkzeug schwenkbar ±90°		CMZ333.2.00
MODULO MOTORIZZATO ORIENTABILE ±90° CON NONIO DIGITALE ±90° adjustable angle driven tool with digital display Angetriebenes Werkzeug schwenkbar ±90° mit digital display		CMZ333.2.01
MODULO MOTORIZZATO ORIENTABILE ±90° ±90° adjustable angle driven tool Angetriebenes Werkzeug schwenkbar ±90°		CMZ335.2.00
MODULO MOTORIZZATO PORTACREATORE Driven gear hobber Angetriebenes Zahnradwaelzfraes-Werkzeug		CMZ340.2.00
MODULO MOTORIZZATO PORTACREATORE RADIALE Radial driven gear hobber Radial Angetriebenes Zahnradwaelzfraes-Werkzeug		CMZ340.2.30
MODULO MOTORIZZATO PORTACREATORE MAGGIORATO Reinforced driven gear hobber Angetriebenes Zahnradwaelzfraes-Werkzeug vergroessert		CMZ340.2.60
MODULO MOTORIZZATO PER VITI SENZA FINE Driven tool for worm screws Angetriebenes werkzeug für schrauben ohne ende		CMZ359.2.00 
MODULO MOTORIZZATO STOZZATORE CORSA 50mm H=80mm Slotting driven tool 50mm stroke H=80mm Keilnutenstossmaschine 50mm Hub H=80mm		CMZ360.2.00 
MODULO MOTORIZZATO STOZZATORE CORSA 25mm H=80mm Slotting driven tool 25mm stroke H=80mm Keilnutenstossmaschine 25mm Hub H=80mm		CMZ360.2.01 

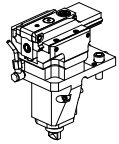
		PAGINA Page Seite
<p>PORTAUTENSILE RADIALE SOVRAPPOSTO QD=25mm Radial single side twin static tool QD=25mm Radial Werkzeughalter ueberlagert QD=25mm</p>		CMZ440.2.00
<p>PORTAUTENSILE RADIALE DOPPIO QD=25mm Radial double static tool QD=25mm Radial Doppel-Werkzeughalter QD=25mm</p>		CMZ453.2.00
<p>PORTAUTENSILE RADIALE DOPPIO SOVRAPPOSTO QD=25mm Radial double side twin static tool QD=25mm Radial Doppel-Werkzeughalter ueberlagert QD=25mm</p>		CMZ460.2.00
<p>PORTAUTENSILE PER LAMA DOPPIO Radial double blade holder Radial Doppel-Abstechhalter</p>		CMZ520.2.00
<p>PORTAUTENSILE PER LAMA DOPPIO CON LUBRIFICAZIONE INTERNA Radial double blade holder with internal coolant Radial Doppel-Abstechhalter mit Innenkuehlung</p>		CMZ520.2.04
<p>PORTAUTENSILE ASSIALE PER BARENO 2 POSIZIONI Ø32mm Axial double boring bar holder Ø32mm Axial Bohrhalter 2 Positionen Ø32mm</p>		CMZ862.2.00
<p>CONTROPUNTA PER CONTROMANDRINO Tailstock for subspindle Gegenspintz fuer Gegenspindel</p>		CMZ950.2.00

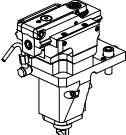

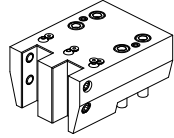
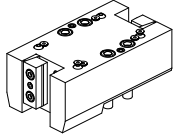
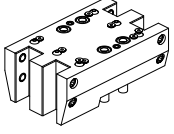
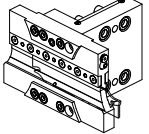
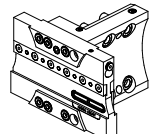
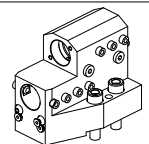
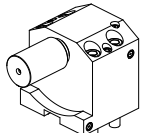
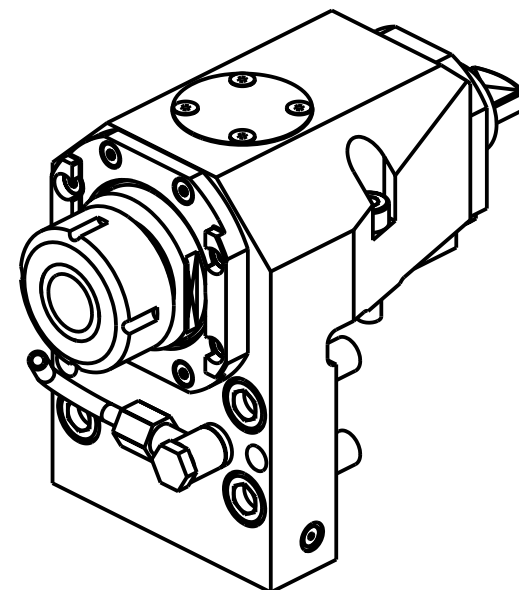
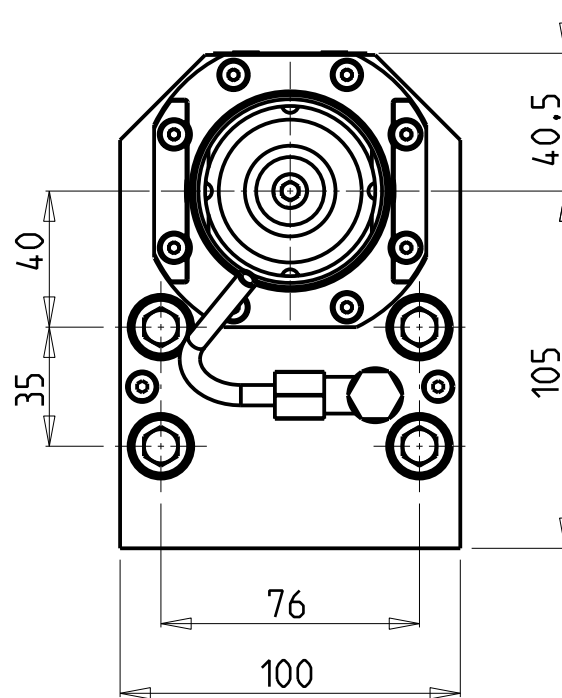
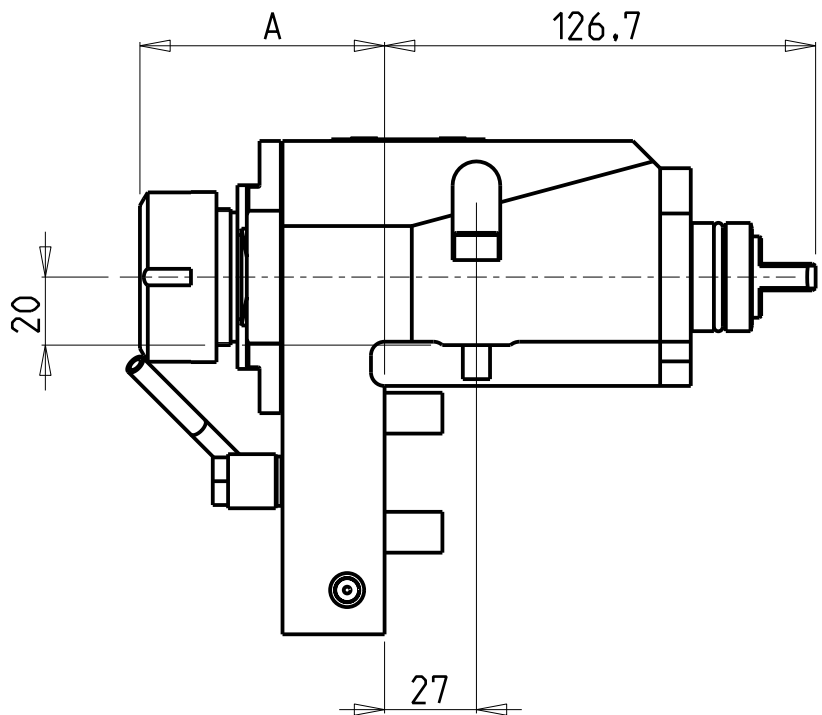
Cod. MT	Mandrino Spindle Spindel	I	RPM	Coppia Max Max Torque Max Drehmoment	Lubrificazione int. Coolant through Innenkuehlung	Lubrificazione est. Ext. coolant Aussenkuehlung	A	CHIAVI NON INCLUSE Keys not included Schlüssel nicht einbegriffen		
MSL0150432	ERA32	1:1	6000	70Nm	P=70bar	X	56.25	CHUB30	MNZ0410005	CHTAER32ZC
MSL0150132	ER32	1:1	6000	70Nm	-	X	71.91	-	MNZ0410005	CHSTER32
MSL0150232	ER32	1:1	6000	70Nm	P=70bar	X	74.91	-	MNZ0410005	CHSTER32

- Chiave inclusa
- Key included
- Schlüssel einbegriffen

CMZ

MOD:TL25AM/AMS/BM/BMS - TL20M/MS/TM - TA15-20-25-30M/Y/MS/MY/YS - TC15-20-25-30-35M/Y/MS/MY/YS
TD15-20-25-30-35-45-55M/Y/MS/MY/YS

MODULO MOTORIZZATO RADIALE

Radial driven tool

Radial angetriebenes Werkzeug

Subject to change without notice.

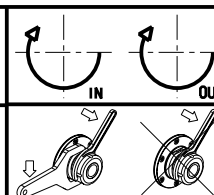

M.T. srl

Via Casino Albini 480
Tel. 0541/956034-957884
Fax 0541/956341
47842 S. GIOVANNI IN M. (RN)
e-mail: mtma@mtmarchetti.com
http://www.mtmarchetti.com

PRODUZIONE MODULI ROTANTI



PAGINA CMZ010-2-00

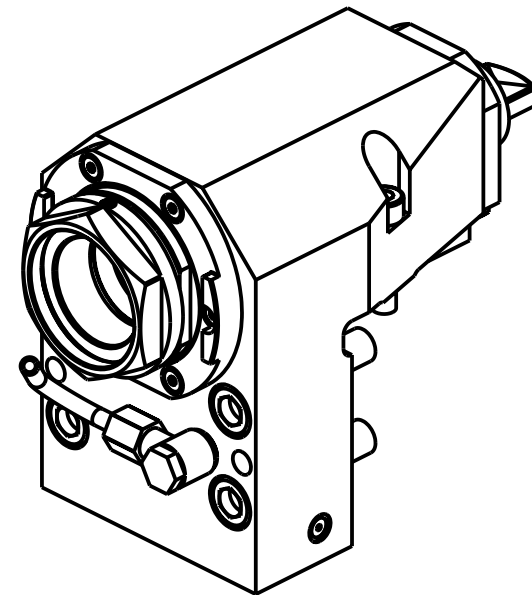
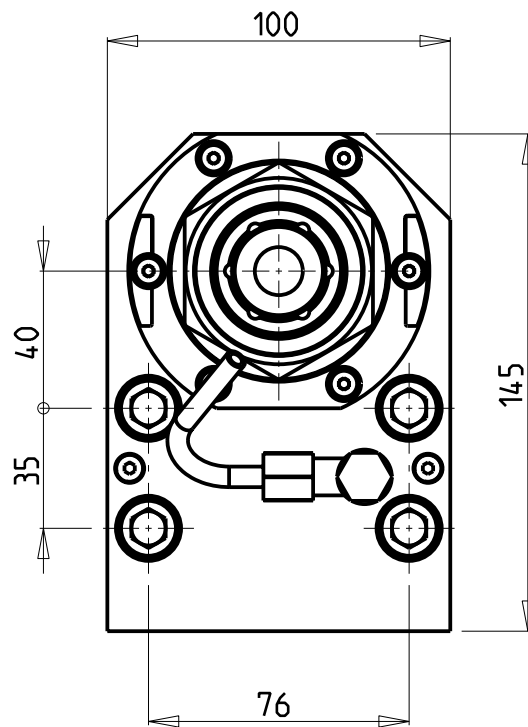
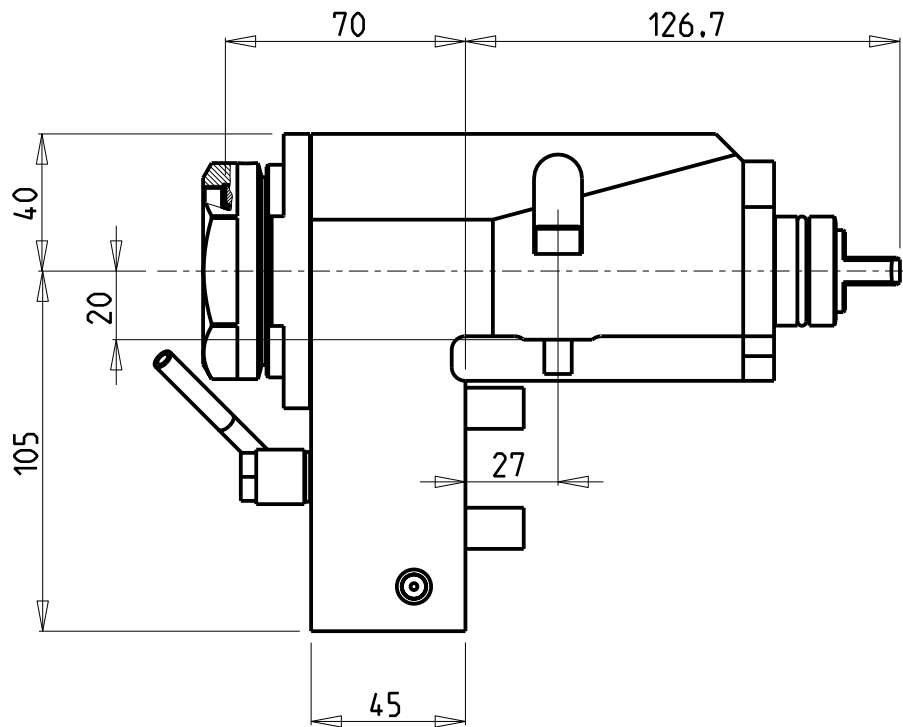

PER PORTAUTENSILI MODULARI MTSK-50 VEDI PAG. TBL300-1-50
 FOR MTSK-50 QUICK CHANGE TOOLHOLDERS CLAMPINGS SEE PAGE TBL300-1-50
 FUER MTSK-50 MODULARE WERKZEUGAUFNAHMEN SIEHE SEITE TBL300-1-50

- Chiave inclusa
- Key included
- Schluessel inbegriffen

Cod. MT	Mandrino Spindle Spindel	I	RPM	Coppia Max Max Torque Max Drehmoment	Lubrificazione est. Ext. coolant Aussenkuehlung	CHIAVI NON INCLUSE Keys not included Schluessel nicht einbegriffen	
MSL0360150	MTSK-50	1:1	6000	70Nm	X	CHUB55	OKU0430007 *

CMZ
 MOD: TL25AM/AMS/BM/BMS - TL20M/MS/TM - TA15-20-25-30M/Y/MS/MY/YS - TC15-20-25-30-35M/Y/MS/MY/YS
 TD15-20-25-30-35-45-55M/Y/MS/MY/YS

MODULO MOTORIZZATO RADIALE MTSK
 Radial MTSK driven tool
 Radial MTSK angetriebenes Werkzeug

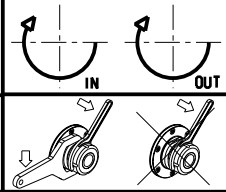

M.T. srl
 Via Casino Albini 480
 Tel. 0541/956034-957884
 Fax 0541/956341
 47842 S. GIOVANNI IN M. (RN)
 e-mail: mtma@mtmarchetti.com
 http://www.mtmarchetti.com

PRODUZIONE MODULI ROTANTI

 PAGINA CMZ010-2-00-K

Subject to change without notice.

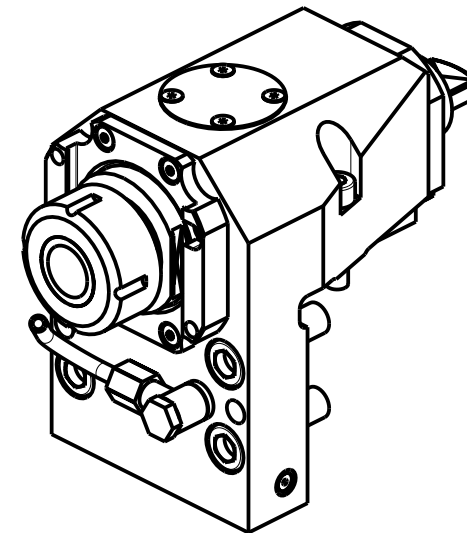
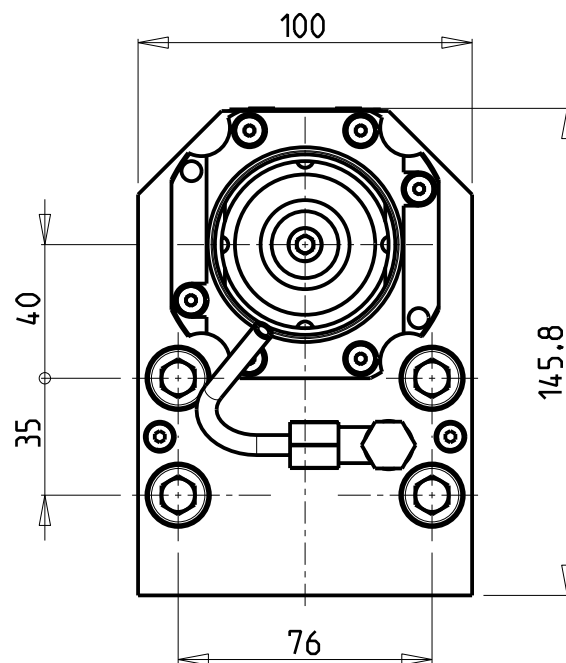
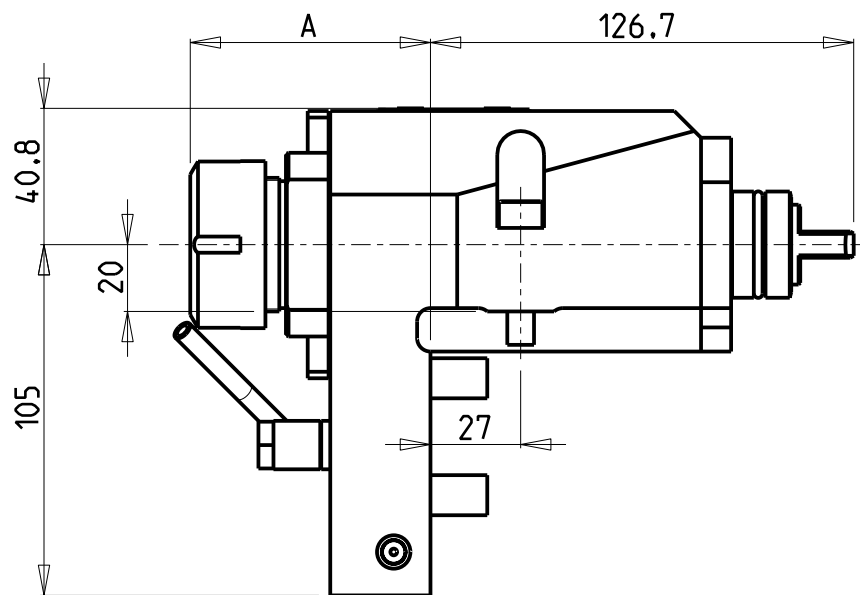
10/2018



- Chiave inclusa
- Key included
- Schlüssel inbegriffen

Cod. MT	Mandrino Spindle Spindel	I	RPM	Coppia Max Max Torque Max Drehmoment	Lubrificazione int. Coolant through Innenkuehlung	Lubrificazione est. Ext. coolant Aussenkuehlung	A	CHIAVI NON INCLUSE Keys not included Schlüssel nicht einbegriffen		
MSL0250132	ER32	1:1	12000	70Nm	-	X	71.91	-	MNZ0410005	CHSTER32
MSL0250232	ER32	1:1	12000	70Nm	P=30bar	X	74.91	-	MNZ0410005	CHSTER32
MSL0250432	ERA32	1:1	12000	70Nm	P=30bar	X	56.25	CHUB30	MNZ0410005	CHTAER32ZC

CMZ

MOD:TL25AM/AMS/BM/BMS - TL20M/MS/TM - TA15-20-25-30M/Y/MS/MY/YS - TC15-20-25-30-35M/Y/MS/MY/YS
TD15-20-25-30-35-45-55M/Y/MS/MY/YS

MODULO MOTORIZZATO RADIALE 12000 RPM
Radial driven tool 12000 rpm
Radial angetriebenes Werkzeug 12000 rpm

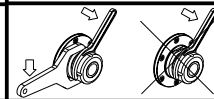
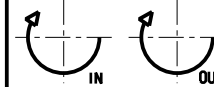

M.T. srl

Via Casino Albini 480
Tel. 0541/956034-957884
Fax 0541/956341
47842 S. GIOVANNI IN M. (RN)
e-mail: mtma@mtmarchetti.com
http://www.mtmarchetti.com

PRODUZIONE MODULI ROTANTI



PAGINA CMZ010-2-01

Subject to change without notice.

10/2018

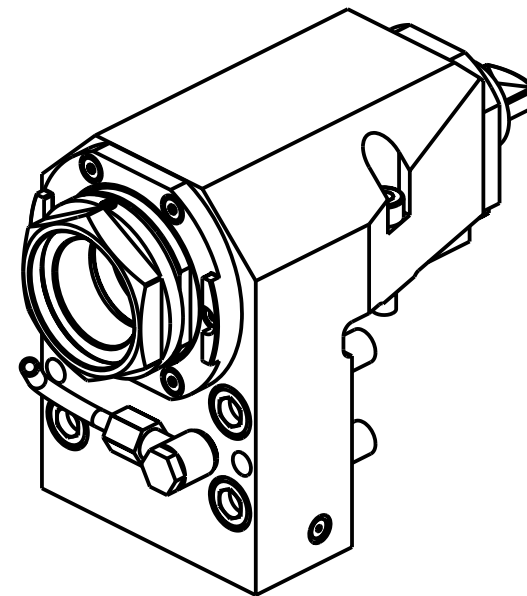
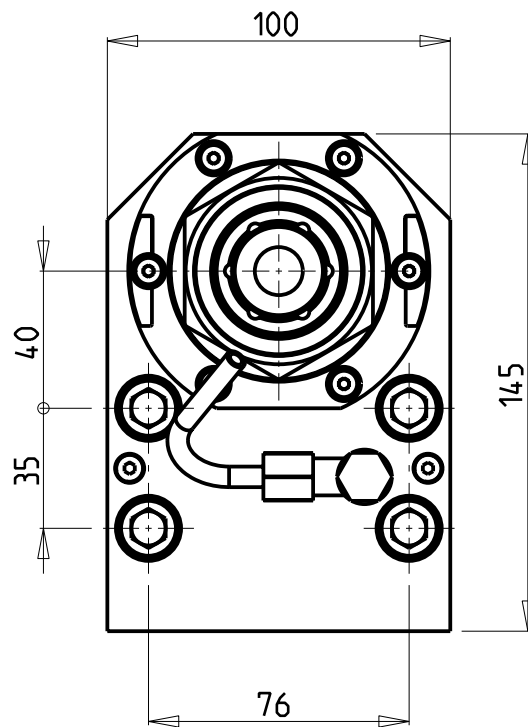
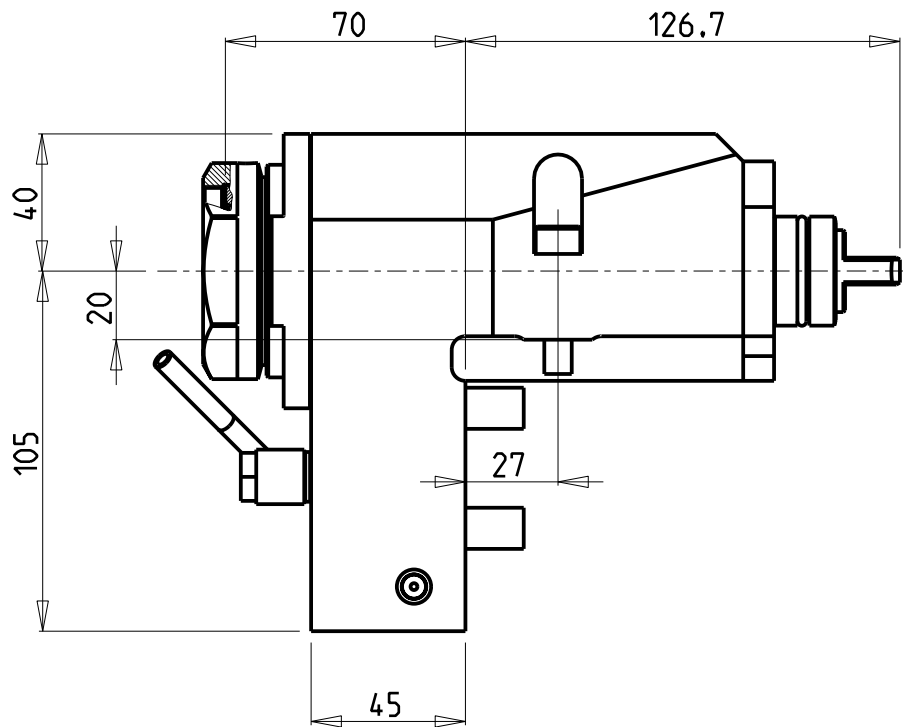

PER PORTAUTENSILI MODULARI MTSK-50 VEDI PAG. TBL300-1-50
 FOR MTSK-50 QUICK CHANGE TOOLHOLDERS CLAMPINGS SEE PAGE TBL300-1-50
 FUER MTSK-50 MODULARE WERKZEUGAUFNAHMEN SIEHE SEITE TBL300-1-50

- Chiave inclusa
- Key included
- Schluessel inbegriffen

Cod. MT	Mandrino Spindle Spindel	I	RPM	Coppia Max Max Torque Max Drehmoment	Lubrificazione est. Ext. coolant Aussenkuehlung	CHIAVI NON INCLUSE Keys not included Schluessel nicht einbegriffen	
MSL0290150	MTSK-50	1:1	12000	70Nm	X	CHUB55	OKU0430007 *

CMZ

MOD: TL25AM/AMS/BM/BMS - TL20M/MS/TM - TA15-20-25-30M/Y/MS/MY/YS - TC15-20-25-30-35M/Y/MS/MY/YS
 TD15-20-25-30-35-45-55M/Y/MS/MY/YS

MODULO MOTORIZZATO RADIALE MTSK 12000 RPM
 Radial MTSK driven tool 12000 rpm
 Radial MTSK angetriebenes Werkzeug 12000 rpm

Subject to change without notice.

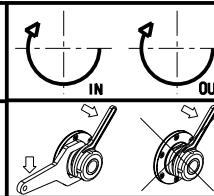

M.T. srl

Via Casino Albini 480
 Tel. 0541/956034-957884
 Fax 0541/956341
 47842 S. GIOVANNI IN M. (RN)
 e-mail: mtma@mtmarchetti.com
 http://www.mtmarchetti.com

PRODUZIONE MODULI ROTANTI



PAGINA CMZ010-2-01-K

10/2018

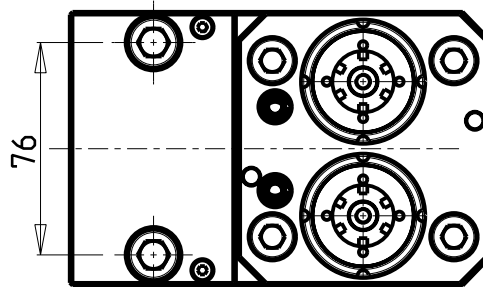
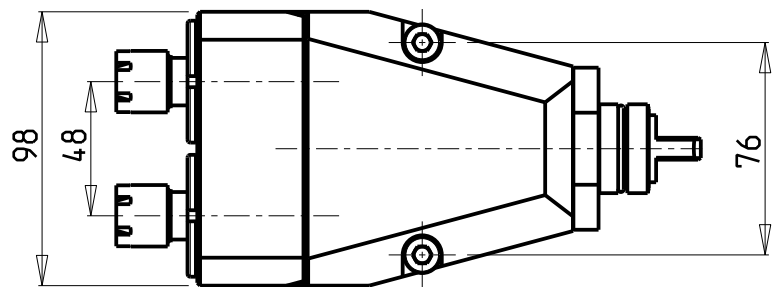
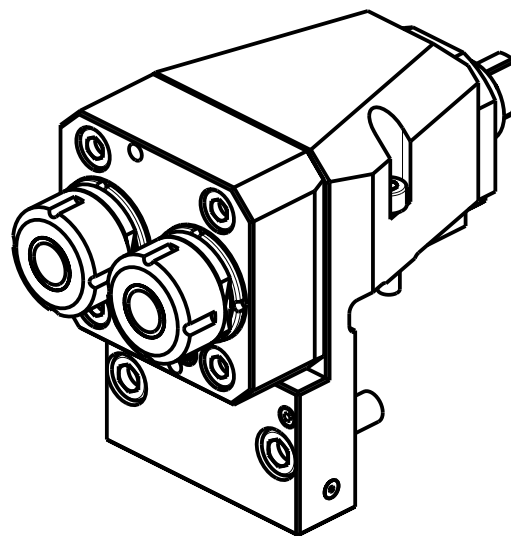
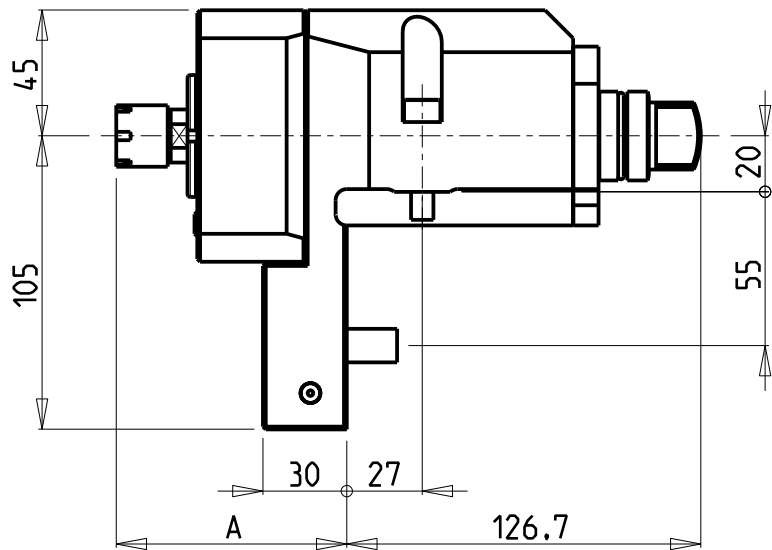

ATTENZIONE - ATTENTION - ACHTUNG

- Per lo smontaggio degli utensili utilizzare sempre la chiave di contrasto come indicato nel manuale d'uso.
- For disassembly of the tools use always the contrast key as mentioned in the user instructions.
- Fuer das Abmontieren der Werkzeuge immer den Gegenschlüssel benutzen wie in der Bedienungsanleitung erwaeht.

Cod. MT	Mandrino Spindle Spindel	I	RPM	Coppia Max Max Torque Max Drehmoment	Lubrificazione est. Ext. coolant Auslenkuehlung	A	CHIAVI NON INCLUSE Keys not included Schlüssel nicht einbegriffen	
							CHUB17	CHMNER16
M0300016	ER16	1:1	6000	30Nm	X	82.5	CHUB17	CHMNER16
M0300025	ER25	1:1	6000	30Nm	X	82.96	MNLO210007	CHSTER25

CMZ

MOD: TA15-20-25-30M/Y/MS/MY/YS - TC15-20-25-30-35M/Y/MS/MY/YS - TD15-20-25-30-35-45-55M/Y/MS/MY/YS

MODULO MOTORIZZATO RADIALE 2 USCITE IN Y
Radial single side twin head driven tool in Y
Radial angetriebenes Werkzeug 2 Ausgaenge in Y

Subject to change without notice.

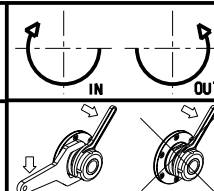

M.T. srl

Via Casino Albini 480
Tel. 0541/956034-957884
Fax 0541/956341
47842 S. GIOVANNI IN M. (RN)
e-mail: mtma@mtmarchetti.com
http://www.mtmarchetti.com

PRODUZIONE MODULI ROTANTI



PAGINA CMZ080-2-00

ATTENZIONE - ATTENTION - ACHTUNG

- Per lo smontaggio degli utensili utilizzare sempre la chiave di contrasto come indicato nel manuale d'uso.
- For disassembly of the tools use always the contrast key as mentioned in the user instructions.
- Fuer das Abmontieren der Werkzeuge immer den Gegenschlüssel benutzen wie in der Bedienungsanleitung erwaeht.

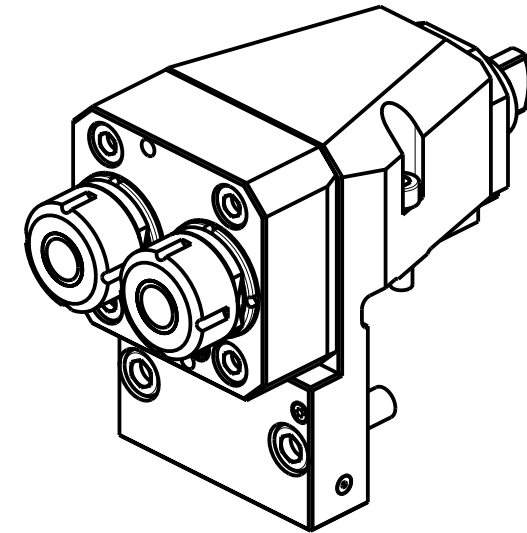
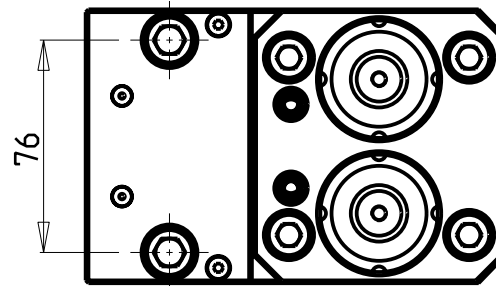
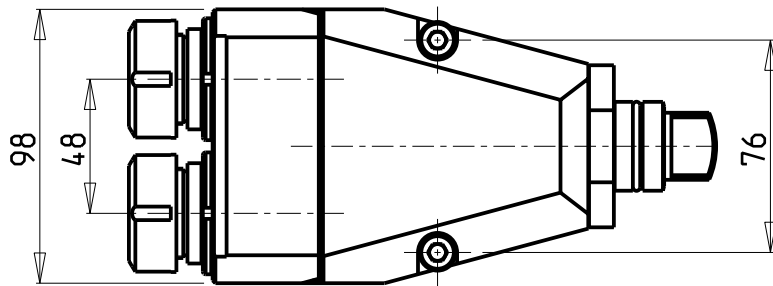
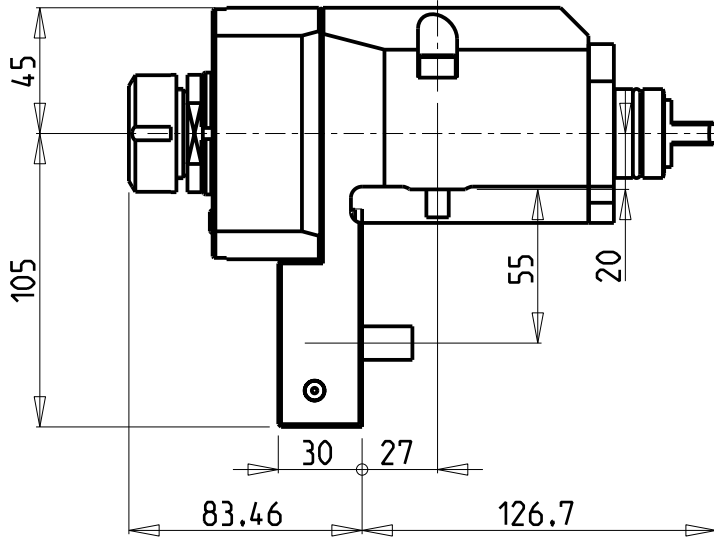

Cod. MT	Mandrino Spindle Spindel	I	RPM	Coppia Max Max Torque Max Drehmoment	Lubrificazione est. Ext. coolant Aussenkuehlung	CHIAVI NON INCLUSE Keys not included Schluesssel nicht einbegriffen	
MSL0470225	ER25	1:1	12000	30Nm	X	MNL0210007	CHSTER25

NEW

CMZ

MOD: TL25AM/AMS/BM/BMS - TL20M/MS/TM - TA15-20-25-30M/Y/MS/MY/YS - TC15-20-25-30-35M/Y/MS/MY/YS
TD15-20-25-30-35-45-55M/Y/MS/MY/YS

MODULO MOTORIZZATO RADIALE 2 USCITE IN Y 12000 RPM
Radial single side twin head driven tool in Y 12000 rpm
Radial angetriebenes Werkzeug 2 Ausgaenge in Y 12000 rpm

Subject to change without notice.

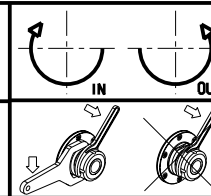

M.T. srl

Via Casino Albini 480
Tel. 0541/956034-957884
Fax 0541/956341
47842 S. GIOVANNI IN M. (RN)
e-mail: mtma@mtmarchetti.com
http://www.mtmarchetti.com

PRODUZIONE MODULI ROTANTI



PAGINA CMZ080-2-01

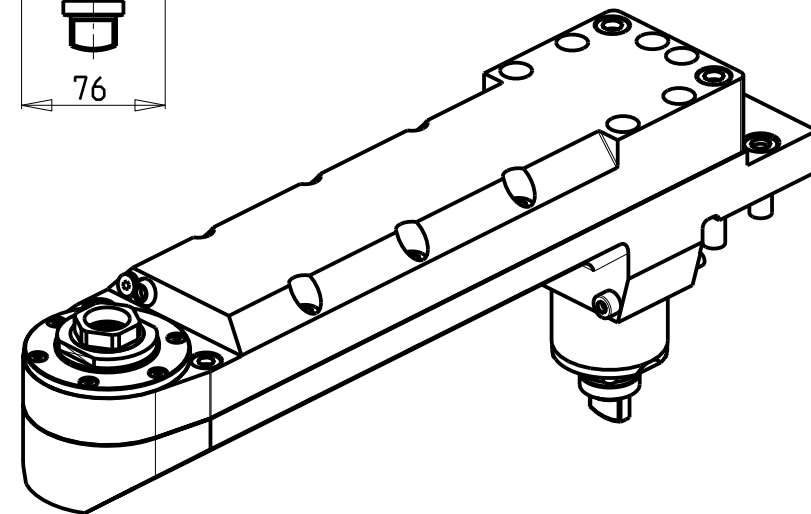
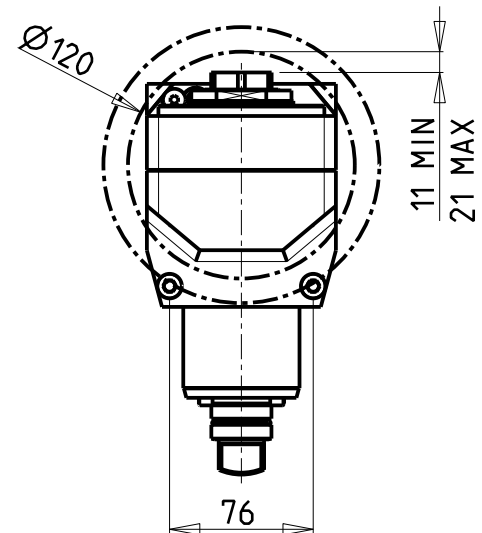
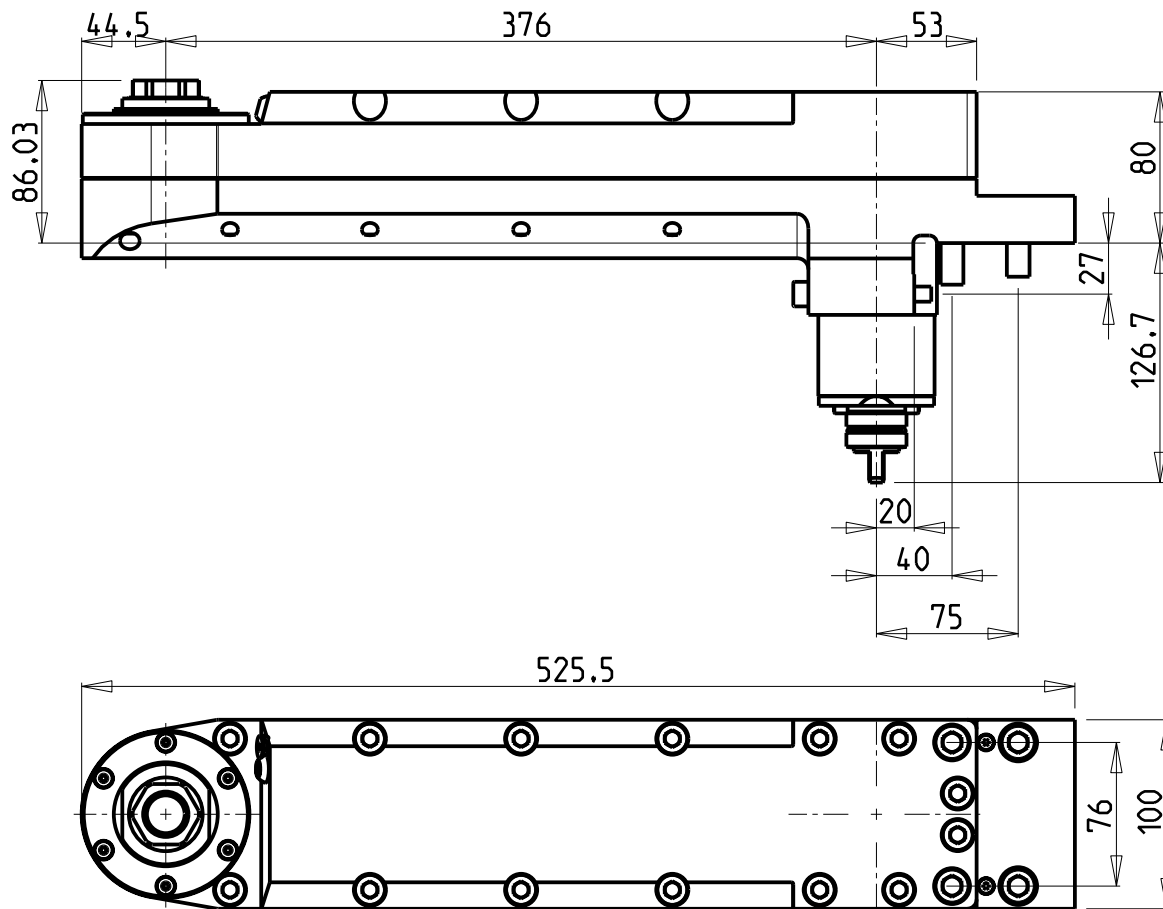

Cod. MT	Mandrino Spindle Spindel	I	RPM	Coppia Max Max Torque Max Drehmoment	Lubrificazione est. Ext. coolant Aussenkuehlung	CHIAVI INCLUSE Keys included Schlüssel inbegriffen	
MSL0010132	ER A 32	1:1	6000	50Nm	X	CHUB46	CHUB32

CMZ

MOD: TL25AM/AMS/BM/BMS - TL20M/MS/TM - TA15-20-25-30M/Y/MS/MY/YS - TC15-20-25-30-35M/Y/MS/MY/YS
TD15-20-25-30-35-45-55M/Y/MS/MY/YS

MODULO MOTORIZZATO SPECIALE RADIALE DISASSATO IN Z 376mm

Radial special driven tool re-directed in Z by 376mm

Radial spezial angetriebenes Werkzeug achsversetzt in Z um 376mm

Subject to change without notice.

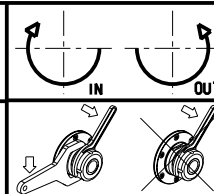

M.T. srl

Via Casino Albini 480
Tel. 0541/956034-957884
Fax 0541/956341

47842 S. GIOVANNI IN M. (RN)
e-mail: mtma@mtmarchetti.com
http://www.mtmarchetti.com

PRODUZIONE MODULI ROTANTI



PAGINA CMZ125-2-10

10/2018

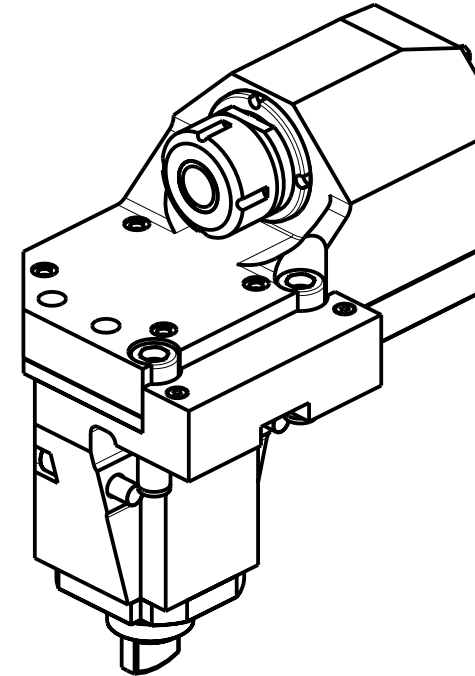
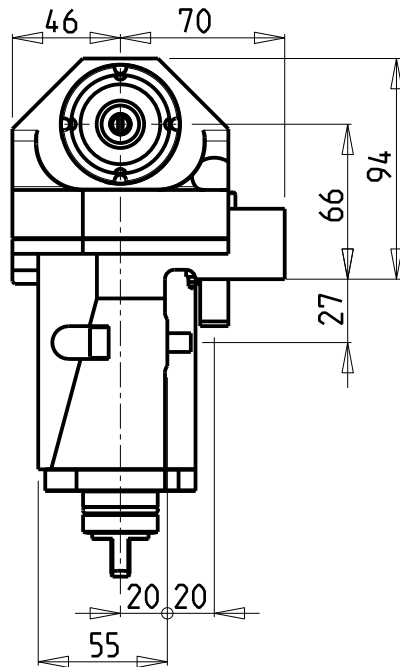
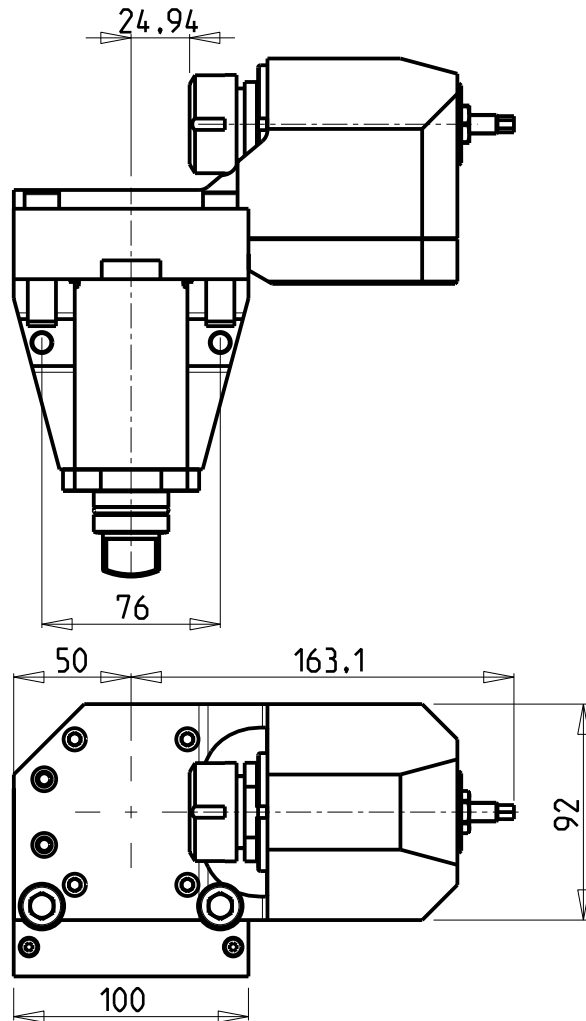

Cod. MT	Mandrino Spindle Spindel	I	RPM	Coppia Max Max Torque Max Drehmoment	Lubrificazione est. Ext. coolant Aussenkuehlung	CHIAVI NON INCLUSE Keys not included Schluessel nicht einbegriffen
M0230025	ER 25	1:1	6000	40Nm	X	CHUB36 CHSTER25

CMZ

MOD: TL25AM/AMS/BM/BMS - TL20M/MS/TM - TA15-20-25-30M/Y/MS/MY/YS - TC15-20-25-30-35M/Y/MS/MY/YS
 TD15-20-25-30-35-45-55M/Y/MS/MY/YS

MODULO MOTORIZZATO SPECIALE RADIALE IN Y
 Radial special driven tool in Y
 Radial spezial angetriebenes Werkzeug in Y

Subject to change without notice.

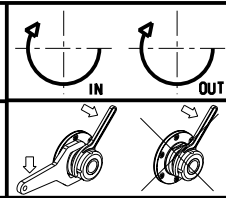

M.T. srl

Via Casino Albini 480
 Tel. 0541/956034-957884
 Fax 0541/956341
 47842 S. GIOVANNI IN M. (RN)
 e-mail: mtma@mtmarchetti.com
 http://www.mtmarchetti.com

PRODUZIONE MODULI ROTANTI



PAGINA CMZ130-2-00

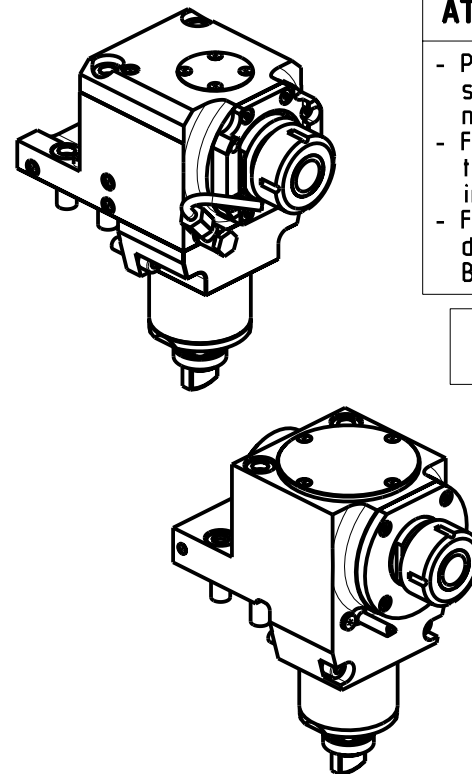
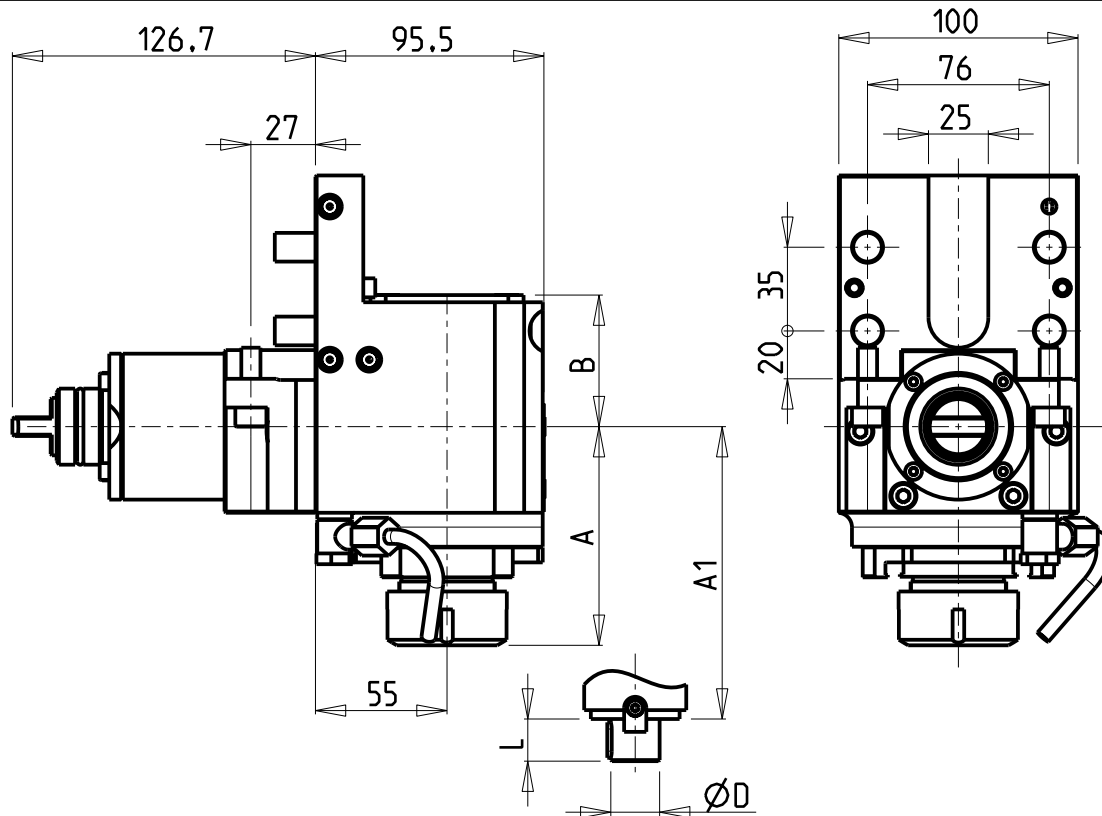

ATTENZIONE - ATTENTION - ACHTUNG

- Per lo smontaggio degli utensili utilizzare sempre la chiave di contrasto come indicato nel manuale d'uso.
- For disassembly of the tools use always the contrast key as mentioned in the user instructions.
- Fuer das Abmontieren der Werkzeuge immer den Gegenschlüssel benutzen wie in der Bedienungsanleitung erwäehnt.

ATTENZIONE - ATTENTION - ACHTUNG

- FINO AD ESAURIMENTO SCORTE
- clearance sale
- solange vorrat

M0030232

- Chiave inclusa
- Key included
- Schluessel inbegriffen

#	Cod. MT	Cod. MORI-SEIKI	Mandrino Spindle Spindel	I	RPM	Coppia Max Max Torque Max Drehmoment	Lubrificazione int. Coolant through Innenkuehlung	Lubrificazione est. Ext. coolant Aussenkuehlung	A	A1	B	D	L	CHIAVI NON INCLUSE Keys not included Schluessel nicht einbegriffen	
#	M0030232	T32154A04	ER32	1:1	6000	70Nm	-	X	93.26	-	66	-	-	CHUB36	CHSTER32
	MSL0160232	-	ER32	1:1	6000	70Nm	P=70bar	X	91.41	-	67.5	-	-	MNZ0410005	CHSTER32
	MSL0160125	-	ER25	1:1	6000	70Nm	-	X	88.41	-	55	-	-	MNZ0410005	CHSTER25
	MSL0160225	-	ER25	1:1	6000	70Nm	P=70bar	X	88.41	-	67.5	-	-	MNZ0410005	CHSTER25
#	M0030516	-	Ø16x17	1:1	6000	70Nm	-	X	-	69.1	66	16	17	CHUB36	CH_VTCROCE_M08

CMZ

MOD: TL25AM/AMS/BM/BMS - TL20M/MS/TM - TA15-20-25-30M/Y/MS/MY/YS - TC15-20-25-30-35M/Y/MS/MY/YS
TD15-20-25-30-35-45-55M/Y/MS/MY/YS

MODULO MOTORIZZATO ASSIALE H=55mm

Axial driven tool H=55mm

Axial angetriebenes Werkzeug H=55mm

Subject to change without notice.

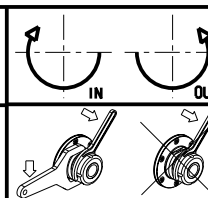

M.T. srl

Via Casino Albini 480
Tel. 0541/956034-957884
Fax 0541/956341
47842 S. GIOVANNI IN M. (RN)
e-mail: mtma@tmarchetti.com
http://www.tmmarchetti.com

PRODUZIONE MODULI ROTANTI



PAGINA CMZ150-2-10

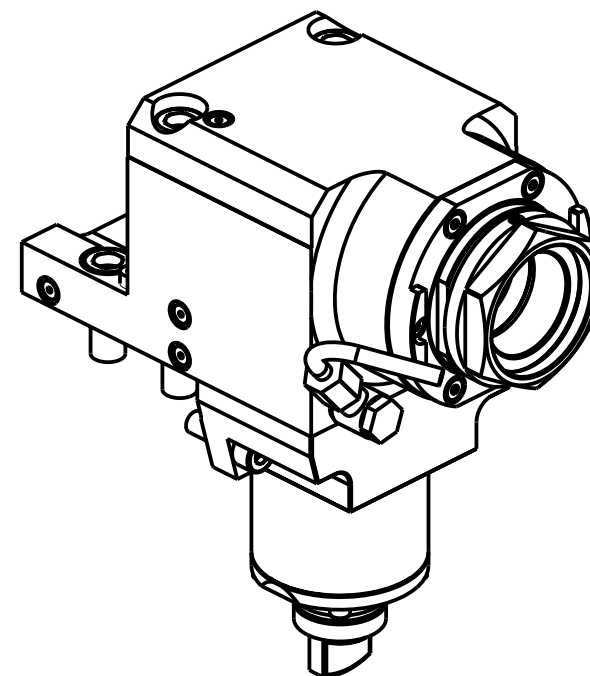
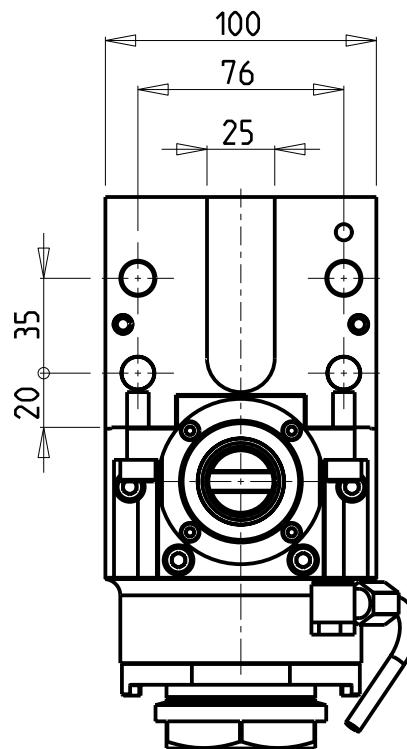
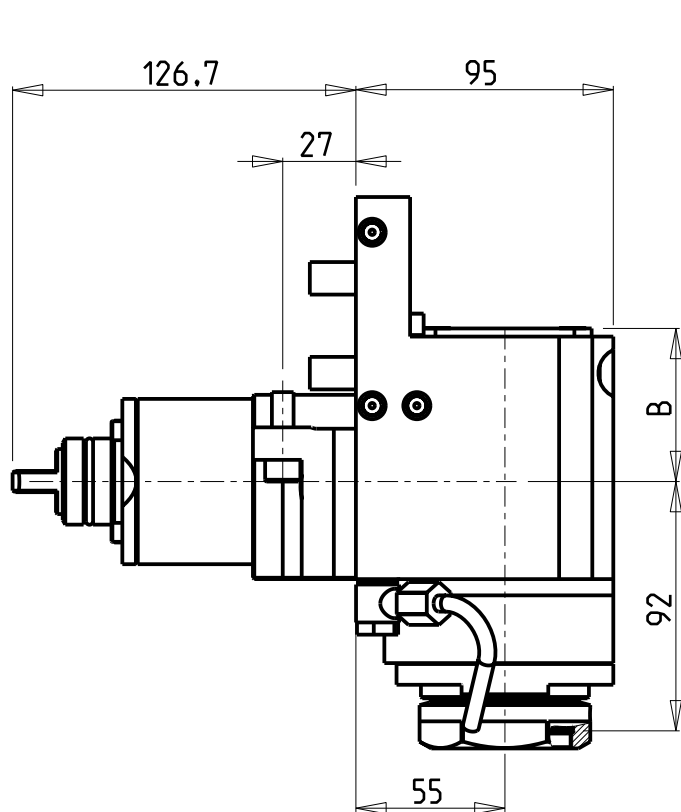

PER PORTAUTENSILI MODULARI MTSK-50 VEDI PAG. TBL300-1-50
 FOR MTSK-50 QUICK CHANGE TOOLHOLDERS CLAMPINGS SEE PAGE TBL300-1-50
 FUER MTSK-50 MODULARE WERKZEUGAUFNAHMEN SIEHE SEITE TBL300-1-50

- Chiave inclusa
- Key included
- Schluessel inbegriffen

Cod. MT	Mandrino Spindel Spindel	I	RPM	Coppia Max Max Torque Max Drehmoment	Lubr.interna Coolant through Innenkuehlung	Lubr.esterna Ext. coolant Aussenkuehlung	B	CHIAVI NON INCLUSE Keys not included Schluessel nicht einbegriffen	
MSL0370150	MTSK-50	1:1	6000	70Nm	-	X	56.5	CHUB55	OKU0430007 •
MSL0370250	MTSK-50	1:1	6000	70Nm	P=70bar	X	70	CHUB55	OKU0430007 •

CMZ

MOD:TL25AM/AMS/BM/BMS - TL20M/MS/TM - TA15-20-25-30M/Y/MS/MY/YS - TC15-20-25-30-35M/Y/MS/MY/YS
 TD15-20-25-30-35-45-55M/Y/MS/MY/YS

MODULO MOTORIZZATO ASSIALE MTSK
 Axial MTSK driven tool
 Axial MTSK angetriebenes Werkzeug

Subject to change without notice.

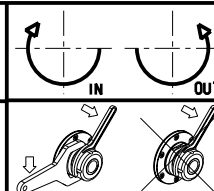

M.T. srl

Via Casino Albini 480
 Tel. 0541/956034-957884
 Fax 0541/956341
 47842 S. GIOVANNI IN M. (RN)
 e-mail: mtma@mtmarchetti.com
 http://www.mtmarchetti.com

PRODUZIONE MODULI ROTANTI



PAGINA CMZ150-2-10-K

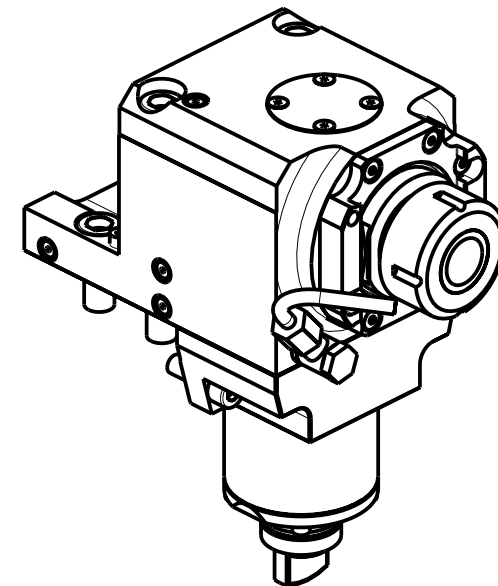
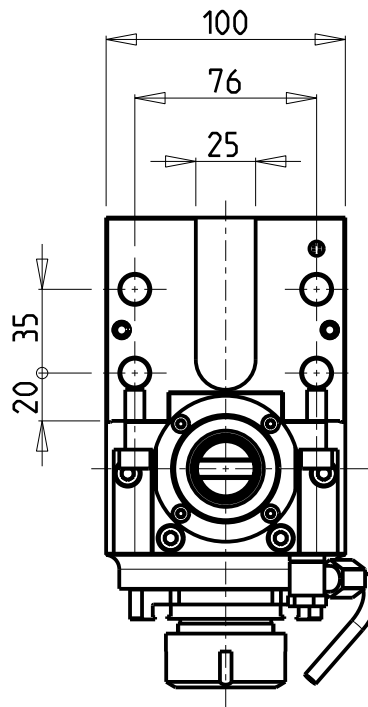
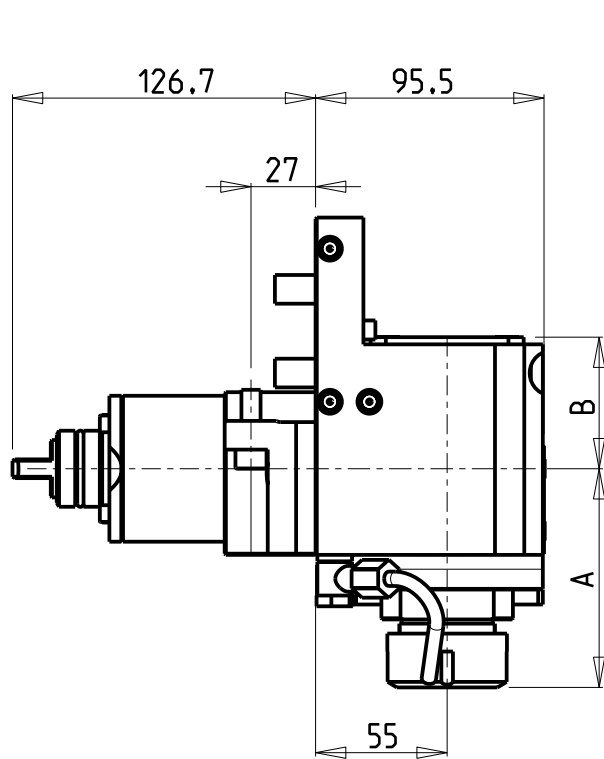

- Chiave inclusa
- Key included
- Schluessel inbegriffen

Cod. MT	Mandrino Spindle Spindel	I	RPM	Coppia Max Max Torque Max Drehmoment	Lubrificazione int. Coolant through Innenkuehlung	Lubrificazione est. Ext. coolant Aussenkuehlung	A	B	CHIAVI NON INCLUSE Keys not included Schluessel nicht einbegriffen	
MSL0260125	ER25	1:1	12000	70Nm	-	X	88.41	55	MNZ0410005 *	CHSTER25
MSL0260225	ER25	1:1	12000	70Nm	P=70bar	X	88.41	67.5	MNZ0410005 *	CHSTER25
MSL0260132	ER32	1:1	12000	70Nm	-	X	91.41	55	MNZ0410005 *	CHSTER32
MSL0260232	ER32	1:1	12000	70Nm	P=70bar	X	91.41	67.5	MNZ0410005 *	CHSTER32

CMZ
 MOD:TL25AM/AMS/BM/BMS - TL20M/MS/TM - TA15-20-25-30M/Y/MS/MY/YS - TC15-20-25-30-35M/Y/MS/MY/YS
 TD15-20-25-30-35-45-55M/Y/MS/MY/YS

MODULO MOTORIZZATO ASSIALE 12000 RPM
 Axial driven tool 12000 rpm
 Axial angetriebenes Werkzeug 12000 rpm

Subject to change without notice.

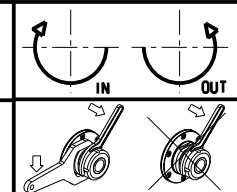

M.T. srl
 Via Casino Albini 480
 Tel. 0541/956034-957884
 Fax 0541/956341
 47842 S. GIOVANNI IN M. (RN)
 e-mail: mtma@mtmarchetti.com
 http://www.mtmarchetti.com

PRODUZIONE MODULI ROTANTI



PAGINA CMZ150-2-11

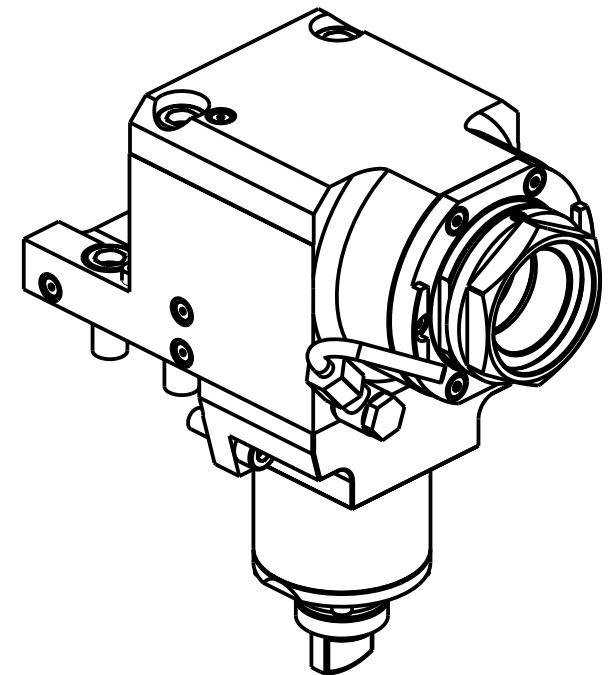
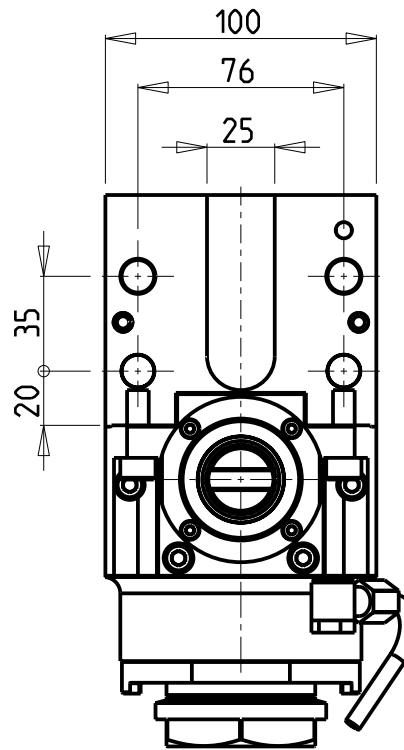
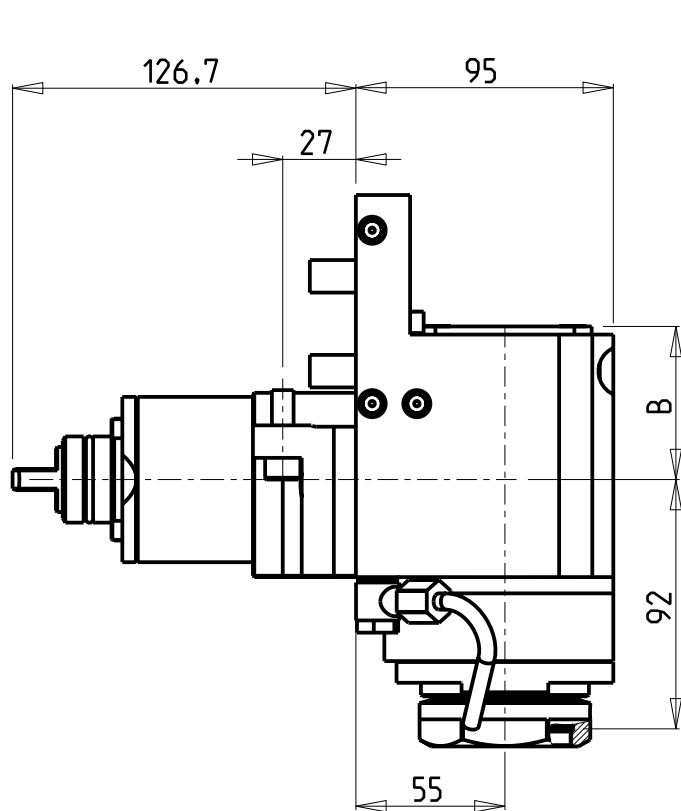

PER PORTAUTENSILI MODULARI MTSK-50 VEDI PAG. TBL300-1-50
 FOR MTSK-50 QUICK CHANGE TOOLHOLDERS CLAMPINGS SEE PAGE TBL300-1-50
 FUER MTSK-50 MODULARE WERKZEUGAUFNAHMEN SIEHE SEITE TBL300-1-50

- Chiave inclusa
- Key included
- Schluessel inbegriffen

Cod. MT	Mandrino Spindel Spindel	I	RPM	Coppia Max Max Torque Max Drehmoment	Lubr.interna Coolant through Innenkuehlung	Lubr.esterna Ext. coolant Aussenkuehlung	B	CHIAVI NON INCLUSE Keys not included Schluessel nicht einbegriffen	
MSL0300150	MTSK-50	1:1	12000	70Nm	-	X	56.5	CHUB55	OKU0430007 •
MSL0300250	MTSK-50	1:1	12000	70Nm	P=70bar	X	70	CHUB55	OKU0430007 •

CMZ
 MOD:TL25AM/AMS/BM/BMS - TL20M/MS/TM - TA15-20-25-30M/Y/MS/MY/YS - TC15-20-25-30-35M/Y/MS/MY/YS
 TD15-20-25-30-35-45-55M/Y/MS/MY/YS

MODULO MOTORIZZATO ASSIALE MTSK 12000 RPM
 Axial MTSK driven tool 12000 rpm
 Axial MTSK angetriebenes Werkzeug 12000 rpm

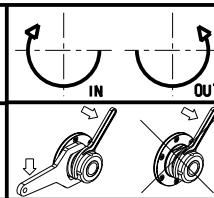

M.T. srl
 Via Casino Albini 480
 Tel. 0541/956034-957884
 Fax 0541/956341
 47842 S. GIOVANNI IN M. (RN)
 e-mail: mtma@mtmarchetti.com
 http://www.mtmarchetti.com

PRODUZIONE MODULI ROTANTI



PAGINA CMZ150-2-11-K

Subject to change without notice.

10/2018

ATTENZIONE - ATTENTION - ACHTUNG

- Per lo smontaggio degli utensili utilizzare sempre la chiave di contrasto come indicato nel manuale d'uso.
- For disassembly of the tools use always the contrast key as mentioned in the user instructions.
- Fuer das Abmontieren der Werkzeuge immer den Gegenschlüssel benutzen wie in der Bedienungsanleitung erwaeht.

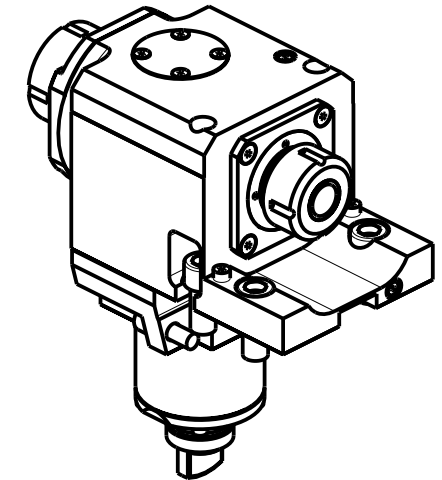
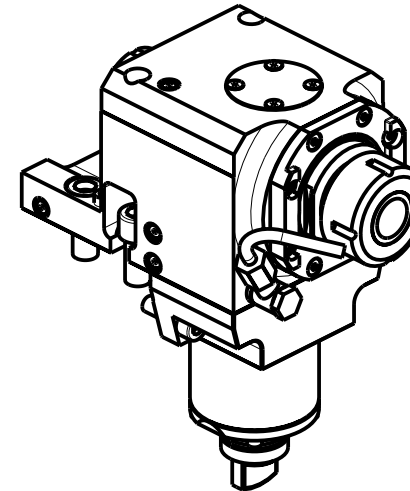
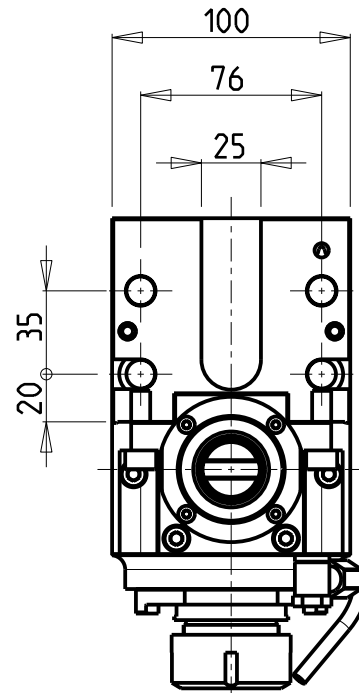
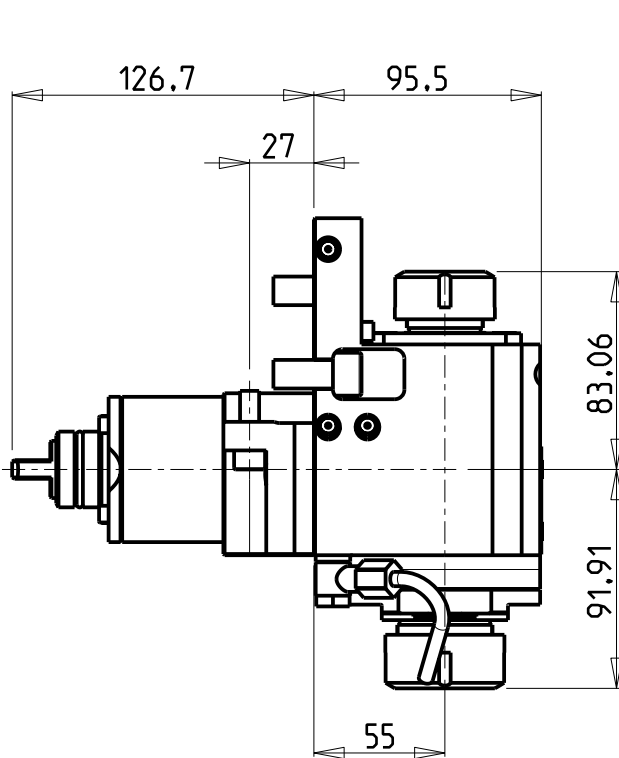

• Chiave inclusa

• Key included

• Schlüssel inbegriffen

Cod. MT	Mandrino Spindle Spindel	I	RPM	Coppia Max Max Torque Max Drehmoment	Lubrificazione est. Ext. coolant Aussenkuehlung	CHIAVI NON INCLUSE Keys not included Schlüssel nicht einbegriffen		
MSL0173225	ER32+ER25	1:1	6000	70Nm	X	MNZ0410005	CHSTER32	CHSTER25

CMZ

MOD: TL25AM/AMS/BM/BMS - TL20M/MS/TM - TA15-20-25-30M/Y/MS/MY/YS - TC15-20-25-30-35M/Y/MS/MY/YS - TD15-20-25-30-35-45-55M/Y/MS/MY/YS

MODULO MOTORIZZATO ASSIALE BISPORGENTE

Axial opposite face twin driven tool

Axial angetriebenes Werkzeug halb vorspringend

Subject to change without notice.

M.T. srl

Via Casino Albini 480
Tel. 0541/956034-957884
Fax 0541/956341
47842 S. GIOVANNI IN M. (RN)
e-mail: mtma@mtmarchetti.com
http://www.mtmarchetti.com

PRODUZIONE MODULI ROTANTI



PAGINA CMZ240-2-10

ATTENZIONE - ATTENTION - ACHTUNG

- Per lo smontaggio degli utensili utilizzare sempre la chiave di contrasto come indicato nel manuale d'uso.
- For disassembly of the tools use always the contrast key as mentioned in the user instructions.
- Fuer das Abmontieren der Werkzeuge immer den Gegenschlüssel benutzen wie in der Bedienungsanleitung erwaeht.

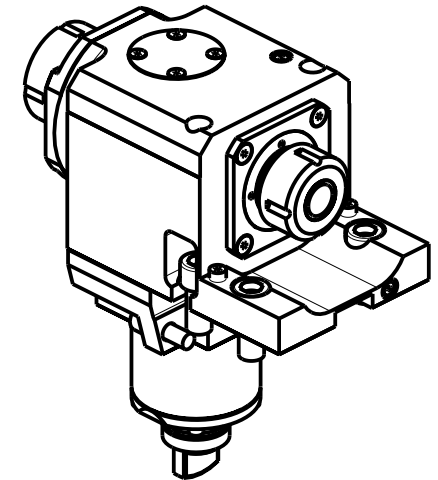
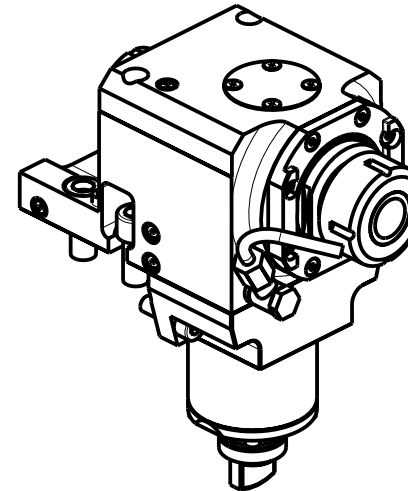
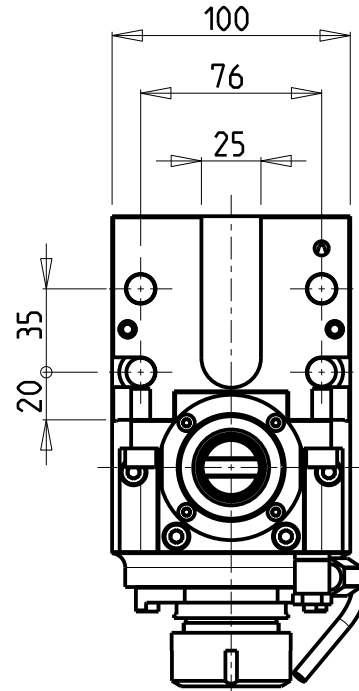
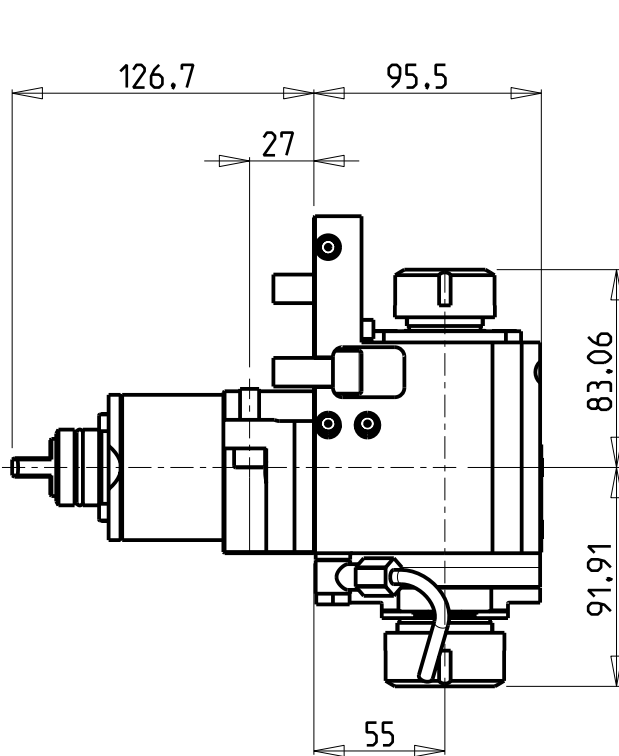

• Chiave inclusa

• Key included

• Schlüssel inbegriffen

Cod. MT	Mandrino Spindle Spindel	I	RPM	Coppia Max Max Torque Max Drehmoment	Lubrificazione est. Ext. coolant Aussenkuehlung	CHIAVI NON INCLUSE Keys not included Schlüssel nicht einbegriffen		
MSL0273225	ER32+ER25	1:1	12000	70Nm	X	MNZ0410005	CHSTER32	CHSTER25

CMZ

MOD: TL25AM/AMS/BM/BMS - TL20M/MS/TM - TA15-20-25-30M/Y/MS/MY/YS - TC15-20-25-30-35M/Y/MS/MY/YS
TD15-20-25-30-35-45-55M/Y/MS/MY/YS

MODULO MOTORIZZATO ASSIALE BISPORGENTE 12000 RPM

Axial opposite face twin driven tool 12000 rpm

Axial angetriebenes Werkzeug halb vorspringend 12000 rpm

Subject to change without notice.

M.T. srl

Via Casino Albini 480
Tel. 0541/956034-957884
Fax 0541/956341
47842 S. GIOVANNI IN M. (RN)
e-mail: mtma@mtmarchetti.com
http://www.mtmarchetti.com

PRODUZIONE MODULI ROTANTI



PAGINA CMZ240-2-11

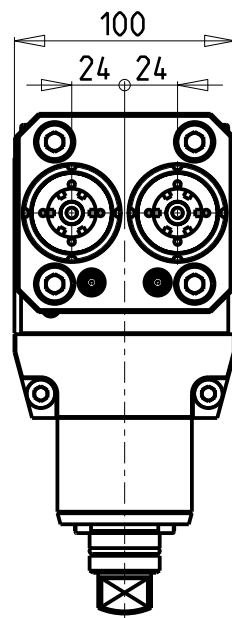
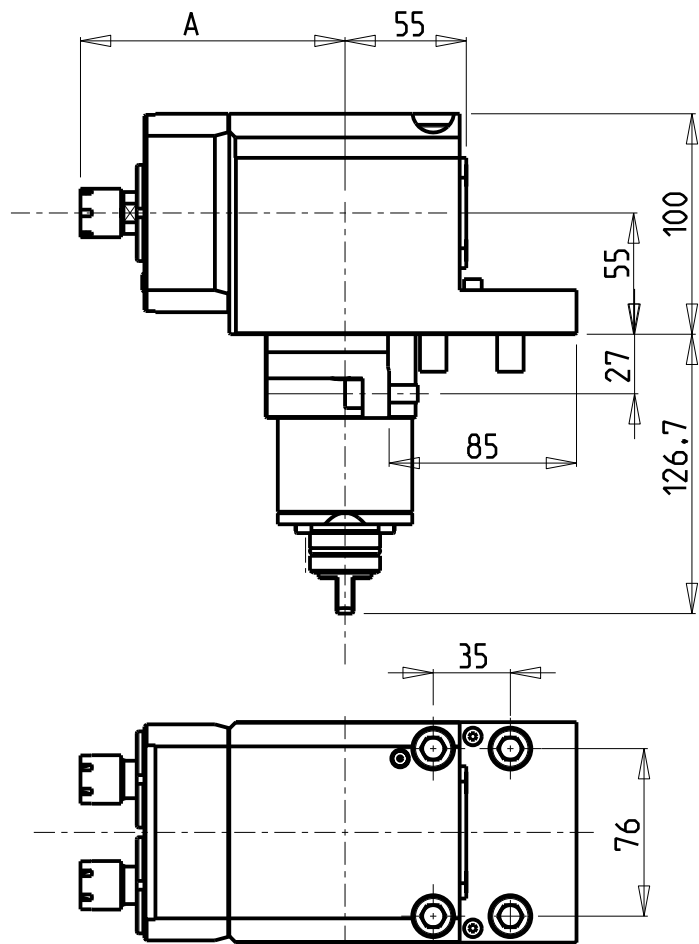

ATTENZIONE - ATTENTION - ACHTUNG

- Per lo smontaggio degli utensili utilizzare sempre la chiave di contrasto come indicato nel manuale d'uso.
- For disassembly of the tools use always the contrast key as mentioned in the user instructions.
- Fuer das Abmontieren der Werkzeuge immer den Gegenschlüssel benutzen wie in der Bedienungsanleitung erwäehnt.

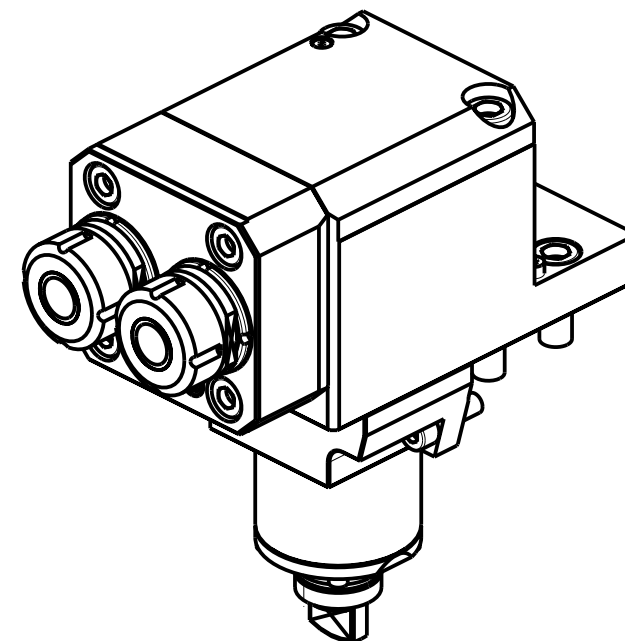

Cod. MT	Mandrino Spindle Spindel	I	RPM	Coppia Max Max Torque Max Drehmoment	Lubrificazione est. Ext. coolant Aussekkuehlung	A	CHIAVI NON INCLUSE Keys not included Schlüssel nicht einbegriffen	
MSL0180216	ER16	1:1	6000	30Nm	X	120	CHUB17	CHMNER16
MSL0180225	ER25	1:1	6000	30Nm	X	121	MNL0210007	CHSTER25

CMZ

MOD:TA15-20-25-30M/Y/MS/MY/YS - TC15-20-25-30-35M/Y/MS/MY/YS - TD15-20-25-30-35-45-55M/Y/MS/MY/YS

MODULO MOTORIZZATO ASSIALE 2 USCITE IN Y
Axial single side twin head driven tool in Y
Axial angetriebenes Werkzeug 2 Ausgaenge in Y

Subject to change without notice.

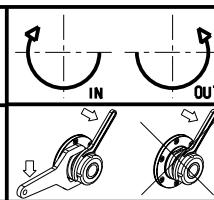

M.T. srl

Via Casino Albini 480
Tel. 0541/956034-957884
Fax 0541/956341
47842 S. GIOVANNI IN M. (RN)
e-mail: mtma@mtmarchetti.com
http://www.mtmarchetti.com

PRODUZIONE MODULI ROTANTI



PAGINA CMZ260-2-10

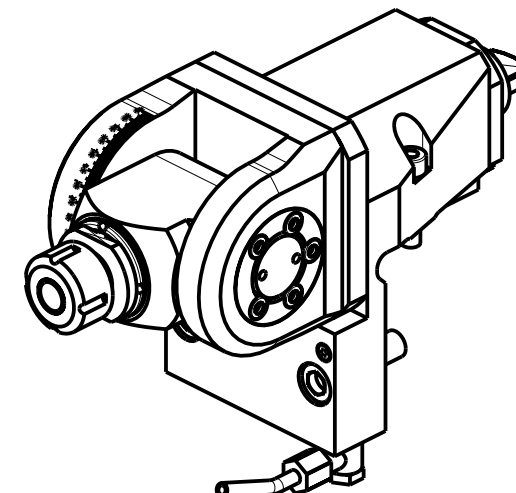
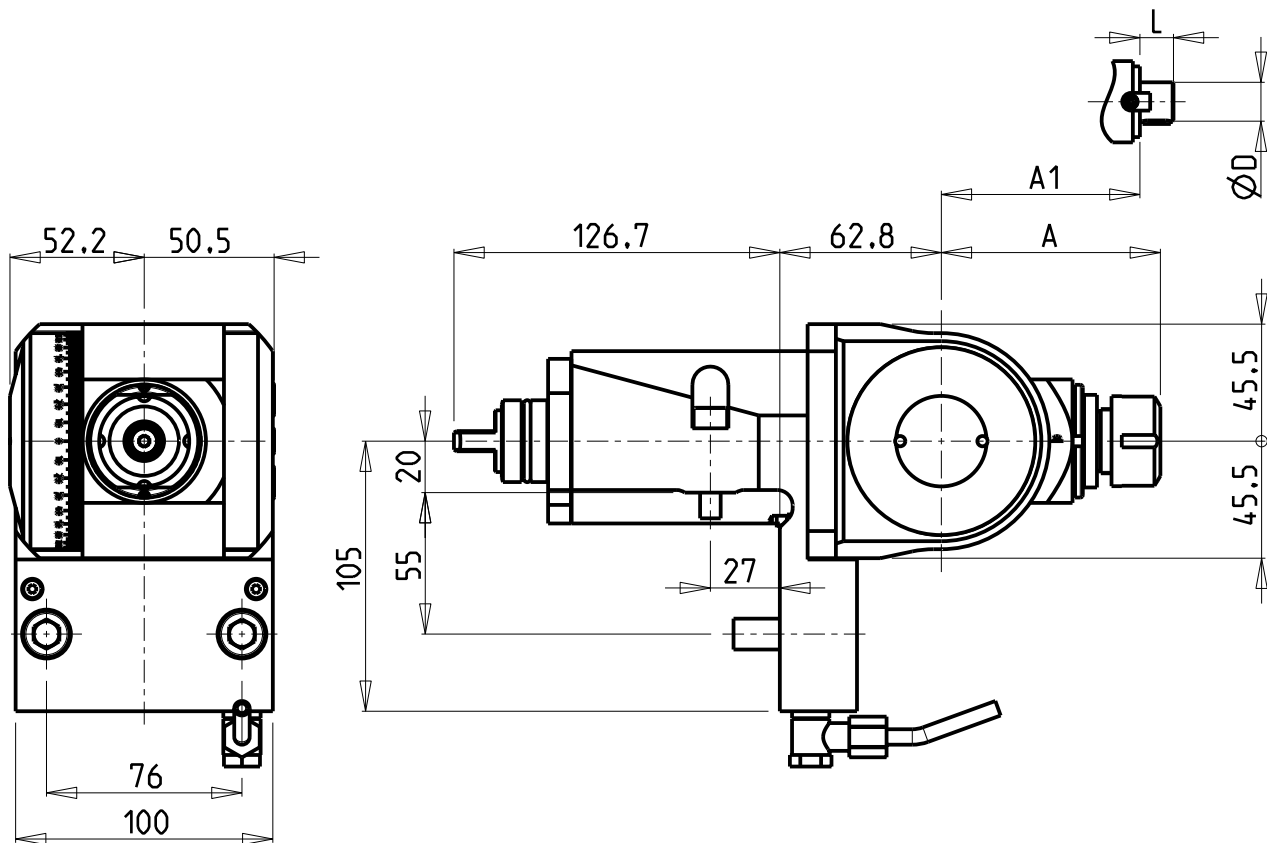

Cod. MT	Mandrino Spindle Spindel	I	RPM	Coppia Max Max Torque Max Drehmoment	Lubrificazione est. Ext. coolant Aussenkuehlung	A	A1	D	L	CHIAVI INCLUSE Keys included Schluessel inbegriffen	
MSL0230120	ER20	1:1	6000	40Nm	X	85.16	-	-	-	CHUB36	CHSTER20
MSL0230125	ER25	1:1	6000	40Nm	X	86.16	-	-	-	CHUB36	CHSTER25
MSL0230516	Ø16x17	1:1	6000	40Nm	X	-	65	16	17	CHUB36	CH_VTCROCE_M08
MSL0230522	Ø22x19	1:1	6000	40Nm	X	-	66	22	19	CHUB36	CH_VTCROCE_M10
MSL0230519	Ø3/4"x3/4"	1:1	6000	40Nm	X	-	65	3/4"	3/4"	CHUB36	CH_VTCROCE_M08

CMZ
 MOD: TL25AM/AMS/BM/BMS - TL20M/MS/TM - TA15-20-25-30M/Y/MS/MY/YS - TC15-20-25-30-35M/Y/MS/MY/YS
 TD15-20-25-30-35-45-55M/Y/MS/MY/YS

MODULO MOTORIZZATO ORIENTABILE ±90°
 ±90° adjustable angle driven tool
 Angetriebenes Werkzeug schwenkbar ±90°

Subject to change without notice.

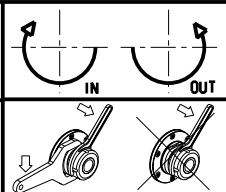

M.T. srl
 Via Casino Albini 480
 Tel. 0541/956034-957884
 Fax 0541/956341
 47842 S. GIOVANNI IN M. (RN)
 e-mail: mtma@mtmarchetti.com
 http://www.mtmarchetti.com

PRODUZIONE MODULI ROTANTI

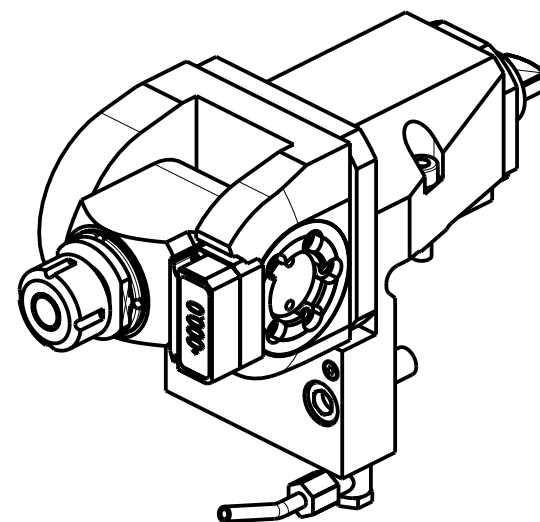
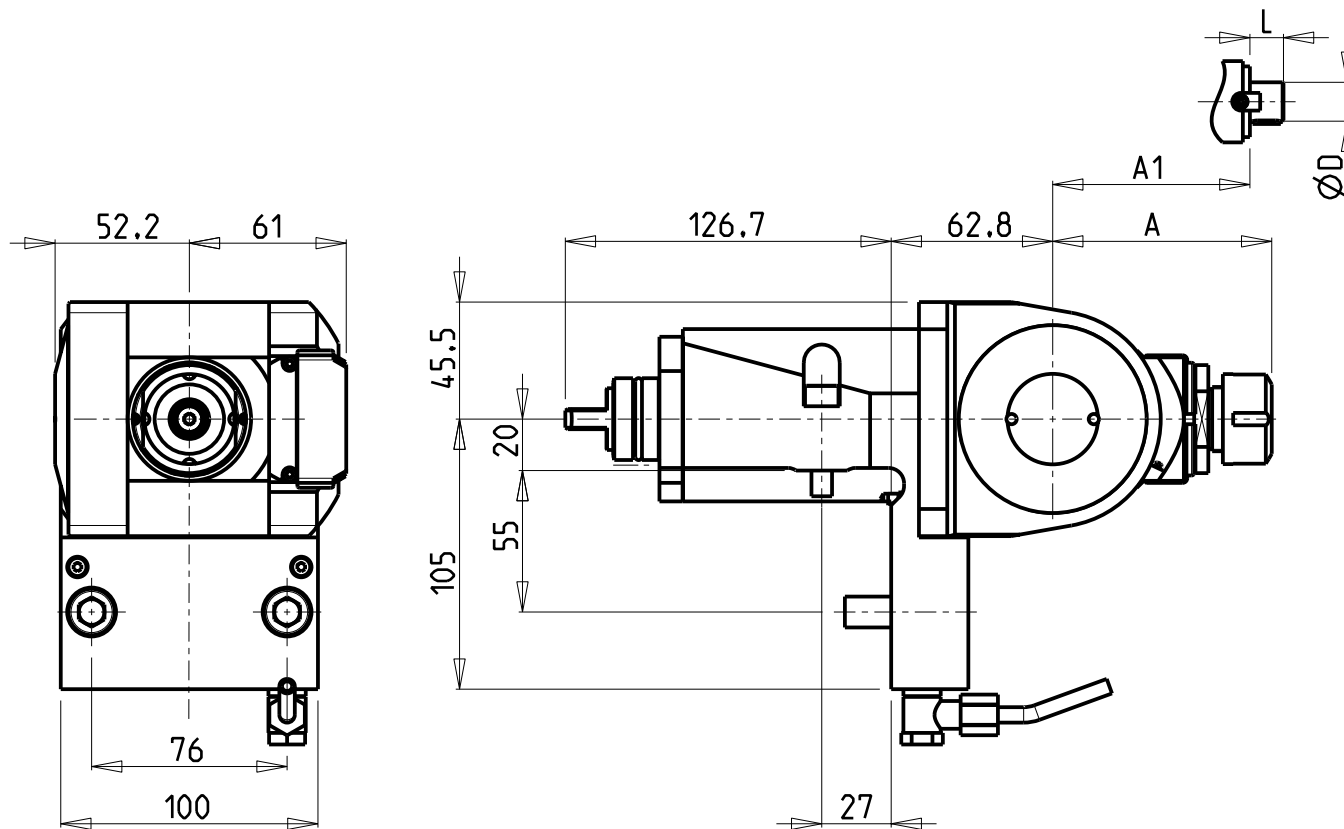
 PAGINA CMZ333-2-00



Cod. MT	Mandrino Spindle Spindel	I	RPM	Coppia Max Max Torque Max Drehmoment	Lubrificazione est. Ext. coolant Aussenkuehlung	A	A1	D	L	CHIAVI INCLUSE Keys included Schlüssel inbegriffen	
MSL0190120	ER20	1:1	6000	40Nm	X	85.16	-	-	-	CHUB36	CHSTER20
MSL0190125	ER25	1:1	6000	40Nm	X	86.16	-	-	-	CHUB36	CHSTER25
MSL0190516	Ø16x17	1:1	6000	40Nm	X	-	65	16	17	CHUB36	CH_VTCROCE_M08
MSL0190522	Ø22x19	1:1	6000	40Nm	X	-	66	22	19	CHUB36	CH_VTCROCE_M10
MSL0190519	Ø3/4"x3/4"	1:1	6000	40Nm	X	-	65	3/4"	3/4"	CHUB36	CH_VTCROCE_M08

CMZ

MOD: TL25AM/AMS/BM/BMS - TL20M/MS/TM - TA15-20-25-30M/Y/MS/MY/YS - TC15-20-25-30-35M/Y/MS/MY/YS
TD15-20-25-30-35-45-55M/Y/MS/MY/YS

MODULO MOTORIZZATO ORIENTABILE ±90° CON NONIO DIGITALE
±90° adjustable angle driven tool with digital display
Angetriebenes Werkzeug schwenkbar ±90° mit digital display

Subject to change without notice.

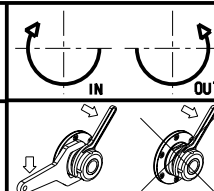

M.T. srl

Via Casino Albini 480
Tel. 0541/956034-957884
Fax 0541/956341

47842 S. GIOVANNI IN M. (RN)
e-mail: mtma@mtmarchetti.com
http://www.mtmarchetti.com

PRODUZIONE MODULI ROTANTI



PAGINA CMZ333-2-01

10/2018

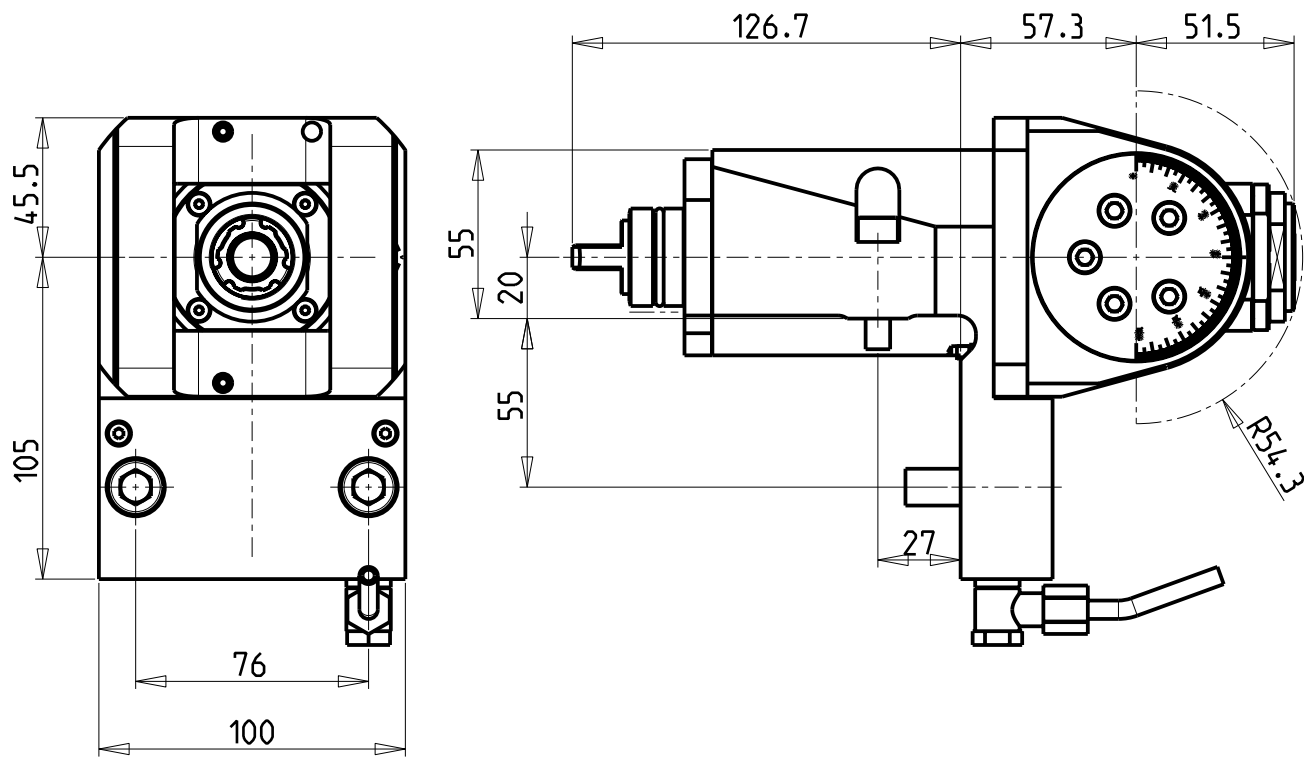

ATTENZIONE - ATTENTION - ACHTUNG

- Per lo smontaggio degli utensili utilizzare sempre la chiave di contrasto come indicato nel manuale d'uso.
- For disassembly of the tools use always the contrast key as mentioned in the user instructions.
- Fuer das Abmontieren der Werkzeuge immer den Gegenschlüssel benutzen wie in der Bedienungsanleitung erwaeht.

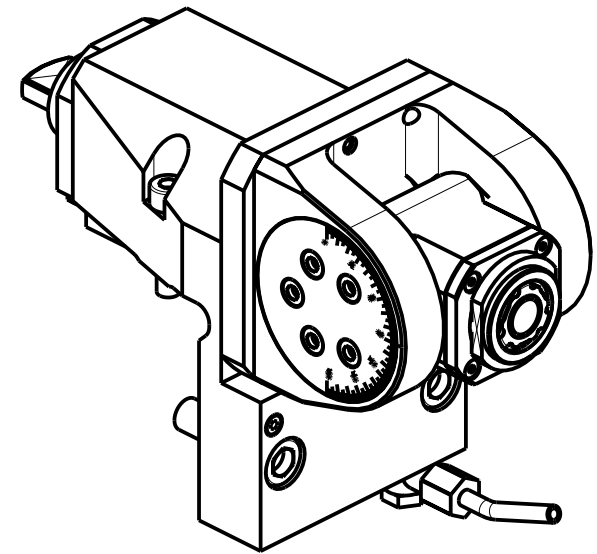

Cod. MT	Mandrino Spindle Spindel	I	RPM	Coppia Max Max Torque Max Drehmoment	Lubrificazione est. Ext. coolant Aussenkuehlung	CHIAVI INCLUSE Keys included Schluessel inbegriffen		
						CHUB36	CHUB22	CHTAER20ZC
M0220020	ER A 20	1:1	6000	30Nm	X	CHUB36	CHUB22	CHTAER20ZC

CMZ

MOD: TL25AM/AMS/BM/BMS - TL20M/MS/TM - TA15-20-25-30M/Y/MS/MY/YS - TC15-20-25-30-35M/Y/MS/MY/YS
TD15-20-25-30-35-45-55M/Y/MS/MY/YS

MODULO MOTORIZZATO ORIENTABILE ±90°

±90° adjustable angle driven tool

Angetriebenes Werkzeug schwenkbar ±90°

Subject to change without notice.

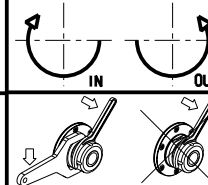

M.T. srl

Via Casino Albini 480
Tel. 0541/956034-957884
Fax 0541/956341
47842 S. GIOVANNI IN M. (RN)
e-mail: mtma@mtmarchetti.com
http://www.mtmarchetti.com

PRODUZIONE MODULI ROTANTI



PAGINA CMZ335-2-00

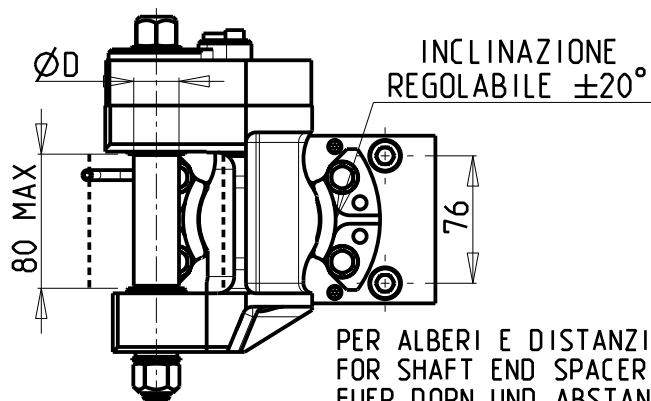
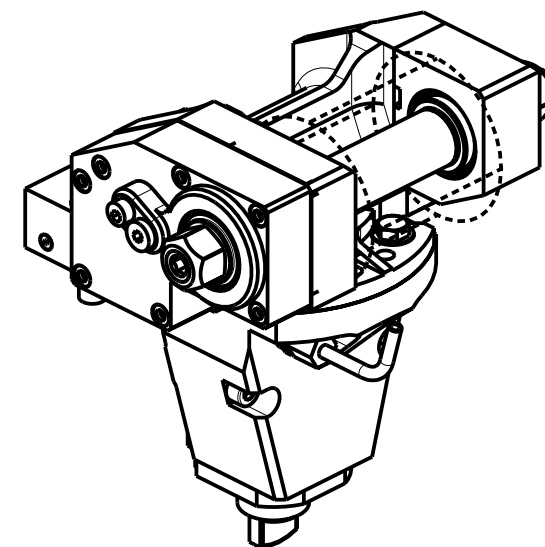
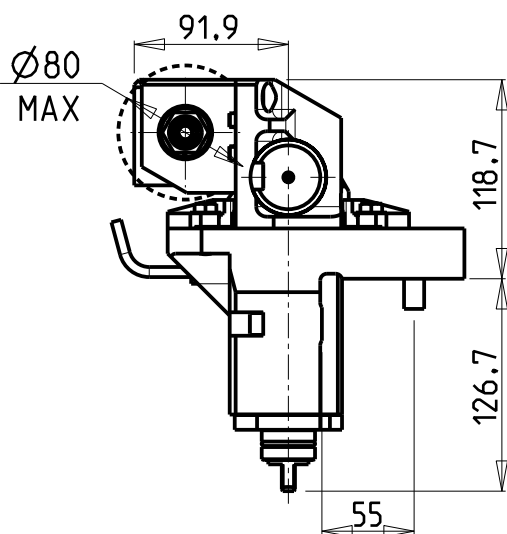
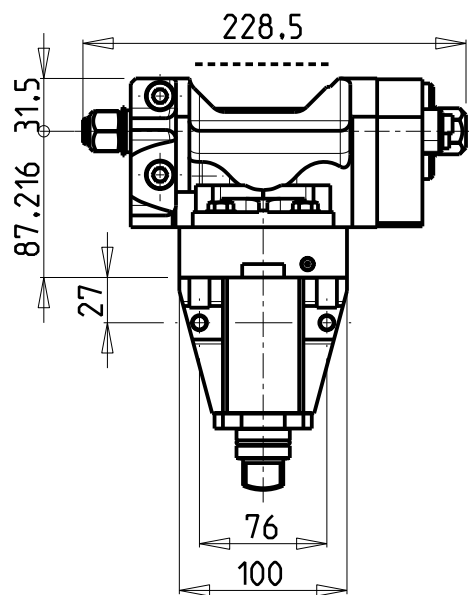

PER ALBERI E DISTANZIALI VEDI PAG. TBL250-1-00
 FOR SHAFT END SPACER SEE PAGE TBL250-1-00
 FUER DORN UND ABSTANDSSTUECK SEITE TBL250-1-00

DOTAZIONI - SUPPLIED WITH - AUSSTATTUNG

- mm / inch**
- N°1 ALBERO + DISTANZIALI
 - N°1 SHAFT + SPACER
 - N°1 DORN + ABSTANDSSTUECK

Cod. MT	I	RPM max	Coppia Max Max Torque Max Drehmoment	Lubrificazione est. Ext. coolant Aussenkuehlung	D (mm)	D (Inch)	CHIAVI INCLUSE Keys included Schluessel inbegriffen		
M0081100	1:1	6000	60Nm	X	16-22-27-32	3/4"-1"-1 1/4"	CHUB24	CHUB13	CHESL08
M0082100	2:1	3000	80Nm	X	16-22-27-32	3/4"-1"-1 1/4"	CHUB24	CHUB13	CHESL08

CMZ

MOD: TL25AM/AMS/BM/BMS - TL20M/MS/TM - TA15-20-25-30M/Y/MS/MY/YS - TC15-20-25-30-35M/Y/MS/MY/YS
 TD15-20-25-30-35-45-55M/Y/MS/MY/YS

MODULO MOTORIZZATO PORTACREATORE

Driven gear hobber

Angetriebenes Zahnradwaeltzraes-Werkzeug

Subject to change without notice.

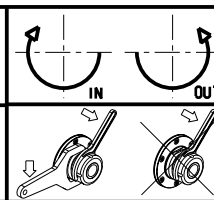

M.T. srl

Via Casino Albini 480
 Tel. 0541/956034-957884
 Fax 0541/956341

47842 S. GIOVANNI IN M. (RN)
 e-mail: mtma@mtmarchetti.com
 http://www.mtmarchetti.com

PRODUZIONE MODULI ROTANTI



PAGINA CMZ340-2-00

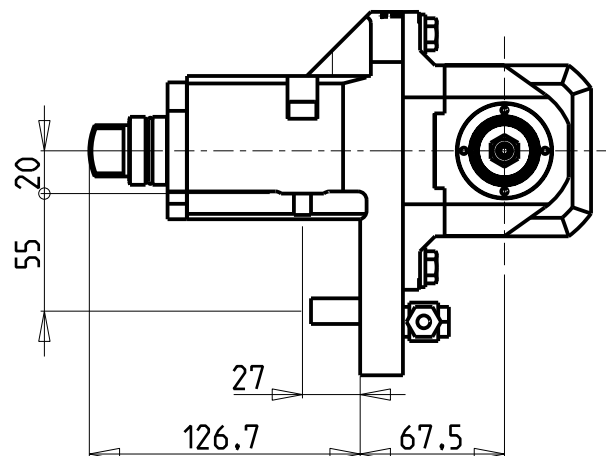
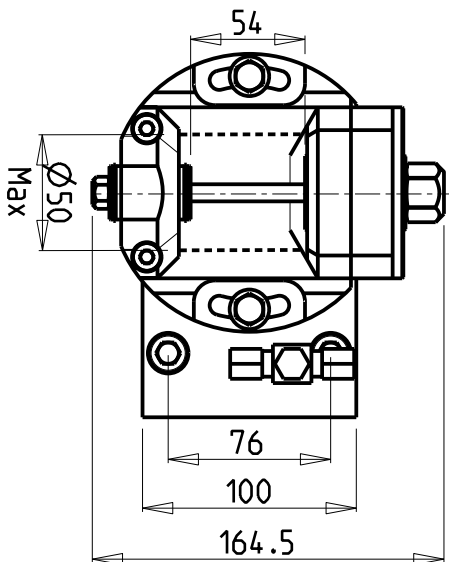

INCLINAZIONE
REGOLABILE ±15°

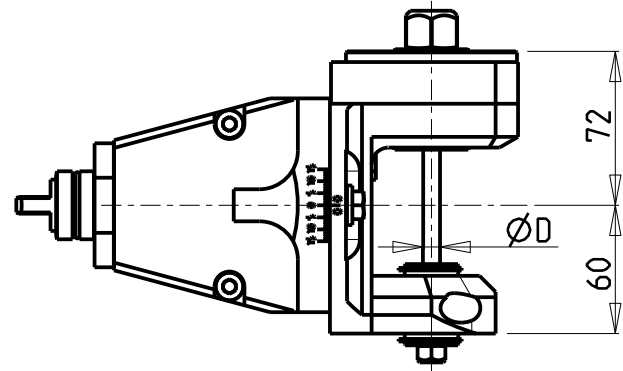
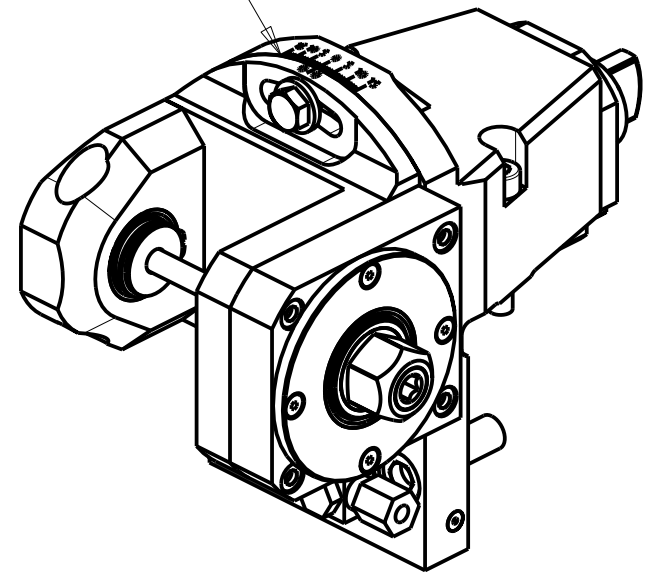

DOTAZIONI - SUPPLIED WITH - AUSSTATTUNG

- N°1 ALBERO + DISTANZIALI
- N°1 SHAFT + SPACER
- N°1 DORN + ABSTANDSSTUECK

Cod. MT	I	RPM max	Coppia Max Max Torque Max Drehmoment	Lubrificazione est. Ext. coolant Aussenkuehlung	D (mm)	CHIAVI INCLUSE Keys included Schluessel inbegriffen				
M0311108	1:1	6000	50Nm	X	8	CHUB24	CHUB13	CHESL08	CHESL04	
M0311110	1:1	6000	50Nm	X	10	CHUB24	CHUB17	CHUB13	CHESL05	CHESL08
M0311113	1:1	6000	50Nm	X	13	CHUB24	CHUB19	CHUB13	CHESL06	CHESL08
M0311116	1:1	6000	50Nm	X	16	CHUB24	CHUB13	CHESL08		

CMZ
 MOD: TL25AM/AMS/BM/BMS - TL20M/MS/TM - TA15-20-25-30M/Y/MS/MY/YS - TC15-20-25-30-35M/Y/MS/MY/YS
 TD15-20-25-30-35-45-55M/Y/MS/MY/YS

MODULO MOTORIZZATO PORTACREATORE RADIALE
 Radial driven gear hobber
 Radial angetriebenes Zahnradwaelzfraes-Werkzeug

Subject to change without notice.

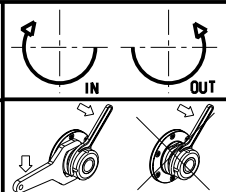

M.T. srl
 Via Casino Albini 480
 Tel. 0541/956034-957884
 Fax 0541/956341
 47842 S. GIOVANNI IN M. (RN)
 e-mail: mtma@mtmarchetti.com
 http://www.mtmarchetti.com

PRODUZIONE MODULI ROTANTI



PAGINA CMZ340-2-30

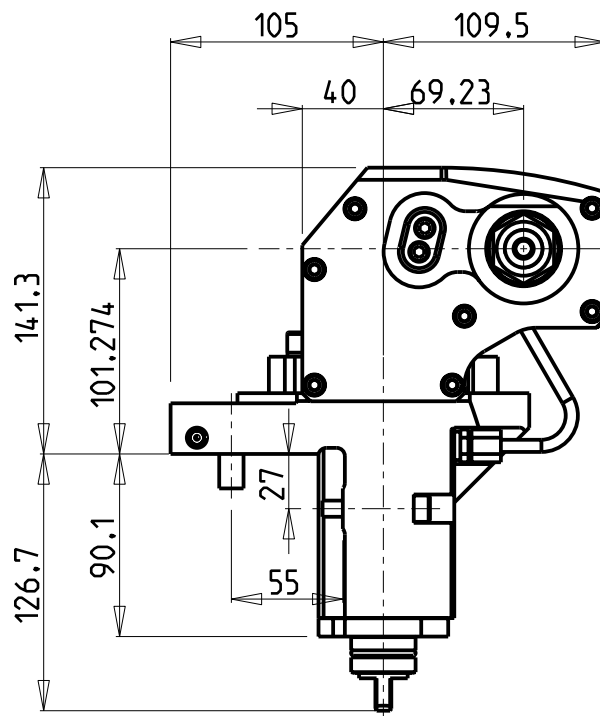
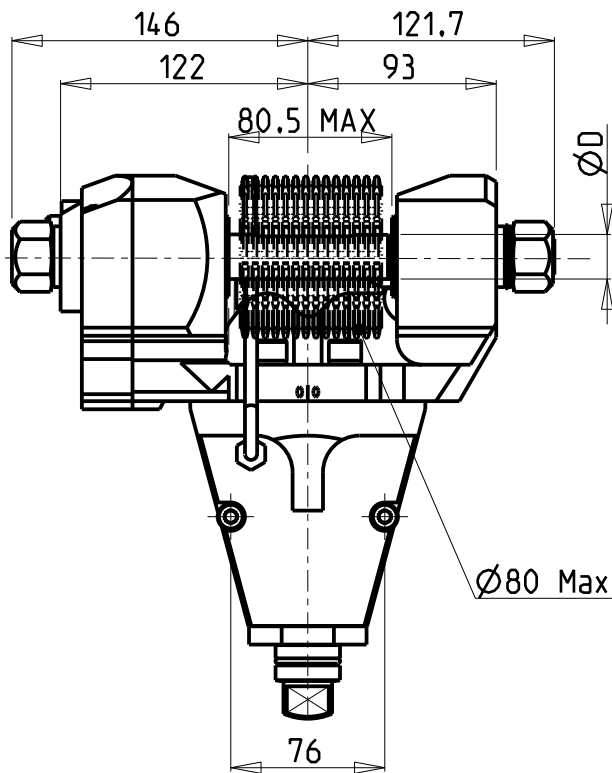

ATTENZIONE - ATTENTION - ACHTUNG

- E' consigliato l'utilizzo su torni dotati di controllo dell'asse Y
- It is recommended to use lathes with the required control of the Y-axis.
- Es ist empfehlenswert Drehbänke, ausgerüstet mit Kontrolle der Y-Achse, zu gebrauchen.

ATTENZIONE - ATTENTION - ACHTUNG

- VERIFICARE LE MISURE DI INGOMBRO PER POSSIBILE INTERFERENZA SU ALCUNI MODELLI DI MACCHINE
- Please check the overall sizes for possible interferences on some machine models
- Bitte überprüfen sie das ausmass um mögliche interferenzen auf einigen maschinen modellen zu vermeiden

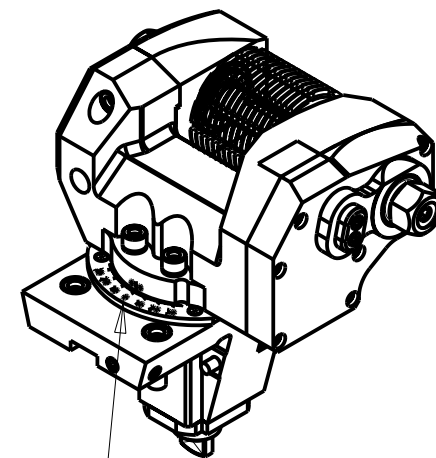

INCLINAZIONE
REGOLABILE ±30°

DOTAZIONI - SUPPLIED WITH - AUSSTATTUNG

- | mm / inch | |
|-----------|-----------------------------|
| | - N°1 ALBERO + DISTANZIALI |
| | - N°1 SHAFT + SPACER |
| | - N°1 DORN + ABSTANDSSTUECK |

PER ALBERI E DISTANZIALI VEDI PAG. TBL250-1-00
FOR SHAFT END SPACER SEE PAGE TBL250-1-00
FUER DORN UND ABSTANDSSTUECK SEITE TBL250-1-00

Cod. MT	I	RPM max	Coppia Max Max Torque Max Drehmoment	Lubrificazione est. Ext. coolant Aussehenkuehlung	D (mm)	D (Inch)	CHIAVI INCLUDE Keys included Schlüssel inbegriffen			
							CHUB30	CHESL08	CHESL10	CHUB24 (Ø16 / Ø3/4")
MSL0381100	1:1	6000	90Nm	X	16-22-27-32	3/4"-1"-1 1/4"	CHUB30	CHESL08	CHESL10	CHUB24 (Ø16 / Ø3/4")

CMZ

MOD: TL25AM/AMS/BM/BMS - TL20M/MS/TM - TA15-20-25-30M/Y/MS/MY/YS - TC15-20-25-30-35M/Y/MS/MY/YS
TD15-20-25-30-35-45-55M/Y/MS/MY/YS

MODULO MOTORIZZATO PORTACREATORE MAGGIORATO

Reinforced driven gear hobber

Angetriebenes Zahnradwaelzfraes-Werkzeug vergroessert

Subject to change without notice.

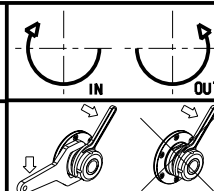

M.T. srl

Via Casino Albini 480
Tel. 0541/956034-957884
Fax 0541/956341

47842 S. GIOVANNI IN M. (RN)
e-mail: mtma@mtmarchetti.com
http://www.mtmarchetti.com

PRODUZIONE MODULI ROTANTI



PAGINA CMZ340-2-60

ATTENZIONE - ATTENTION - ACHTUNG

- VERIFICARE LE MISURE DI INGOMBRO PER POSSIBILE INTERFERENZA SU ALCUNI MODELLI DI MACCHINE
- Please check the overall sizes for possible interferences on some machine models
- Bitte überprüfen sie das ausmass um mögliche interferenzen auf einigen maschinen modellen zu vermeiden

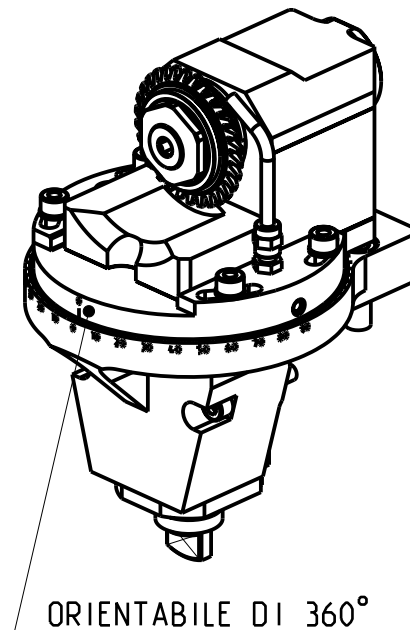
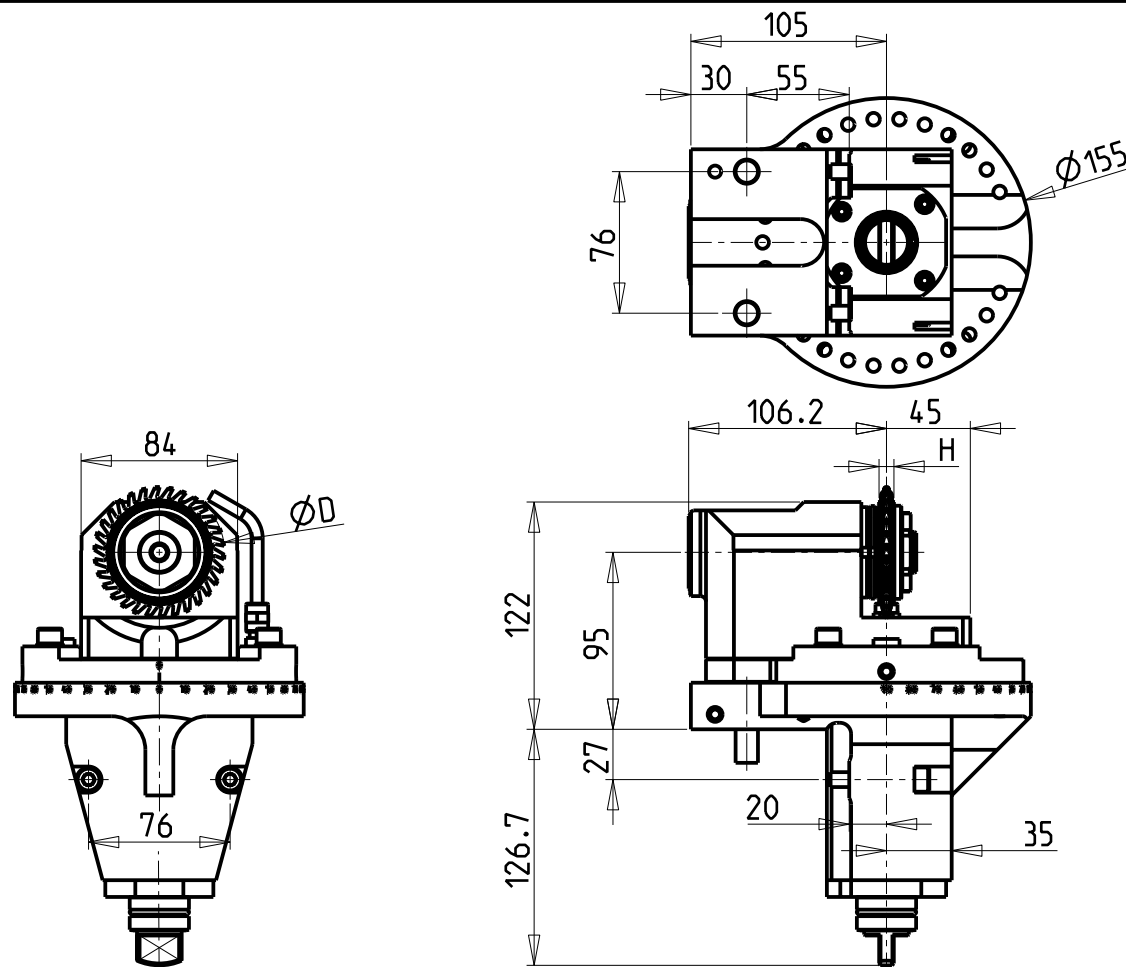

Cod. MT	Mandrino Spindle Spindel	I	RPM	Coppia Max Max Torque Max Drehmoment	Lubrificazione est. Ext. coolant Aussenkuehlung	ØD	H	CHIAVI INCLUSE Keys included Schluessel einbegriffen	
MSL0428022	Ø22x12	1:1	6000	50Nm	X	63-70-80	MAX 12	CHUB38	CHESLO8

NEW

CMZ
 MOD: TL25AM/AMS/BM/BMS - TL20M/MS/TM - TA15-20-25-30M/Y/MS/MY/YS - TC15-20-25-30-35M/Y/MS/MY/YS
 TD15-20-25-30-35-45-55M/Y/MS/MY/YS

MODULO MOTORIZZATO PER VITI SENZA FINE
 Driven tool for worm screws
 Angetriebenes werkzeug für schrauben ohne ende

Subject to change without notice.

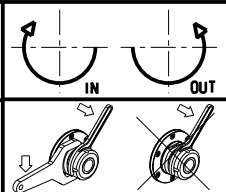

M.T. srl
 Via Casino Albini 480
 Tel. 0541/956034-957884
 Fax 0541/956341
 47842 S. GIOVANNI IN M. (RN)
 e-mail: mtma@mtmarchetti.com
 http://www.mtmarchetti.com

PRODUZIONE MODULI ROTANTI



PAGINA CMZ359-2-00

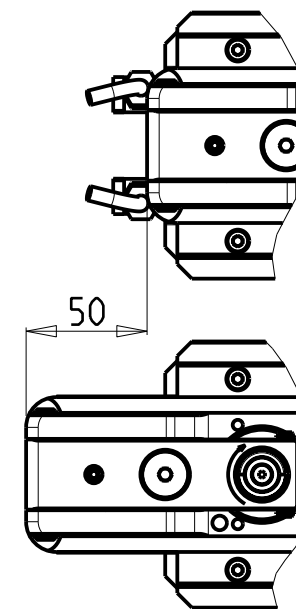
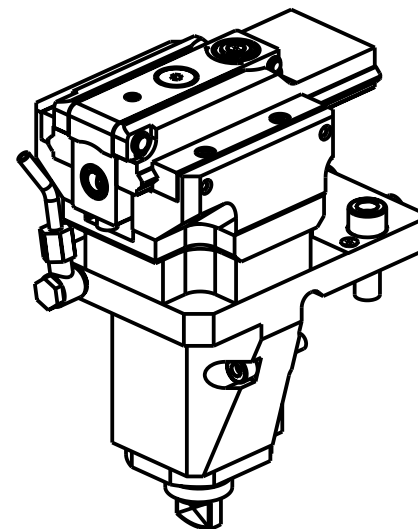
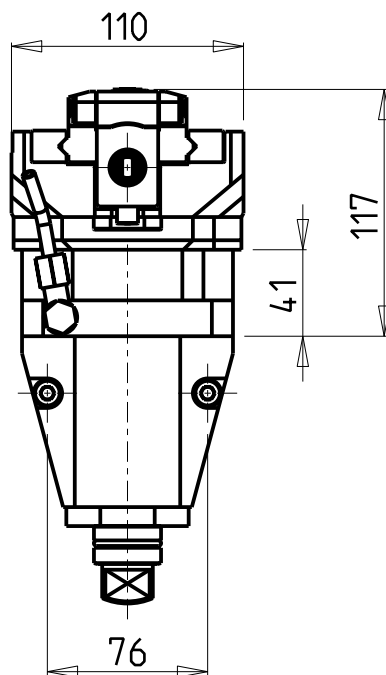
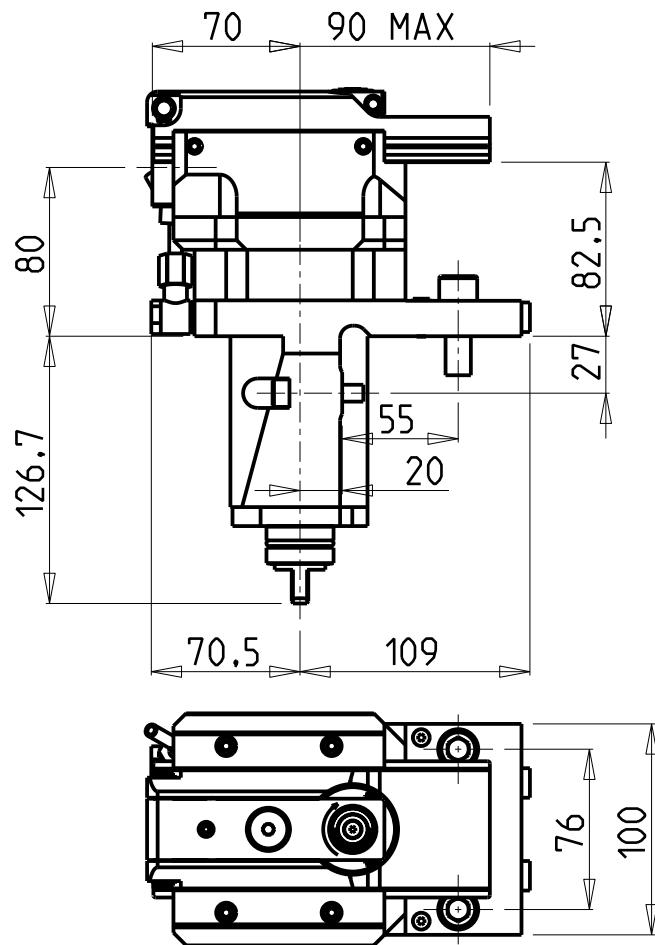

ATTENZIONE - ATTENTION - ACHTUNG

- VERIFICARE LE MISURE DI INGOMBRO PER POSSIBILE INTERFERENZA SU ALCUNI MODELLI DI MACCHINE
- Please check the overall sizes for possible interferences on some machine models
- Bitte überprüfen sie das ausmass um mögliche interferenzen auf einigen maschinen modellen zu vermeiden

PER UTENSILI STOZZATORI VEDI PAG. TBL400-1-00
 FOR DRIVEN SLOTTING TOOL CUTTING-TOOLS SEE PAGE TBL400-1-00
 FÜR NUTENSTOSS-WERKZEUG SCHNEIDWERKZEUGE SIEHE SEITE TBL400-1-00

Cod. MT	I	RPM MAX	Lubr. esterna Ext. coolant Aussenkuehlung
MSL0460100	4:1	2000	X

NEW

CMZ

MOD: TL25AM/AMS/BM/BMS - TL20M/MS/TM - TA15-20-25-30M/Y/MS/MY/YS - TC15-20-25-30-35M/Y/MS/MY/YS
 TD15-20-25-30-35-45-55M/Y/MS/MY/YS

MODULO MOTORIZZATO STOZZATORE CORSA 50mm H=80mm
 Slotting driven tool 50mm stroke H=80mm
 Keilnutenstossmaschine 50mm Hub H=80mm

Subject to change without notice.

M.T. srl

Via Casino Albini 480
 Tel. 0541/956034-957884
 Fax 0541/956341
 47842 S. GIOVANNI IN M. (RN)
 e-mail: mtma@mtmarchetti.com
 http://www.mtmarchetti.com

PRODUZIONE MODULI ROTANTI



PAGINA CMZ360-2-00

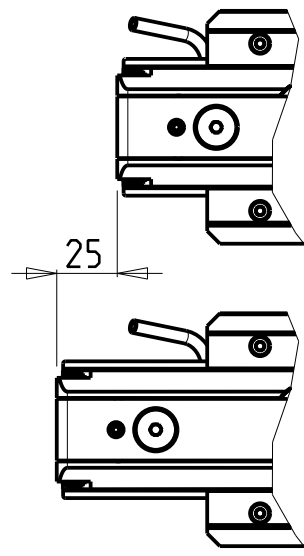
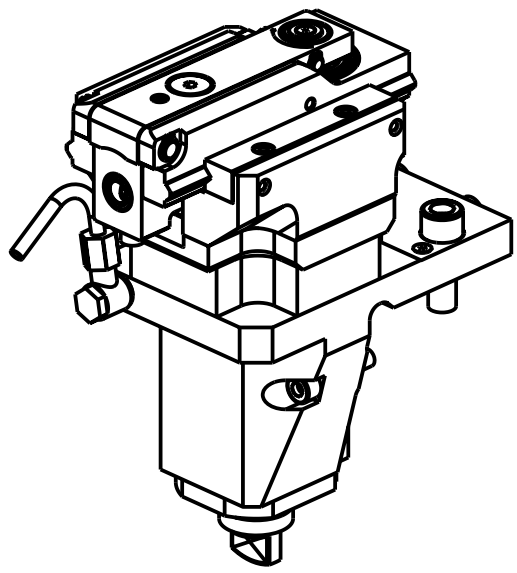
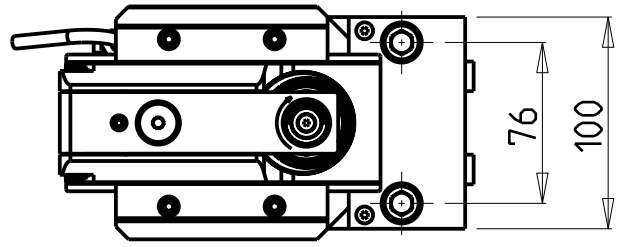
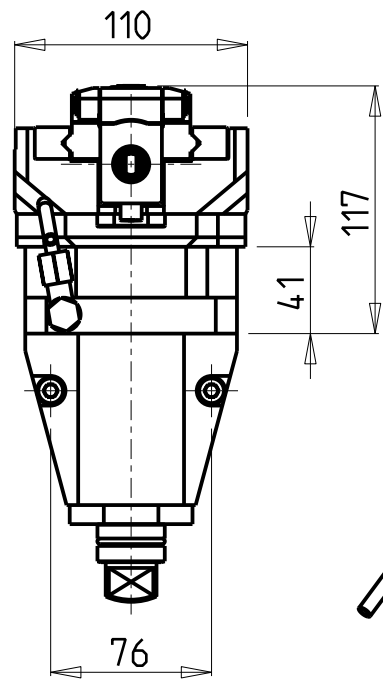
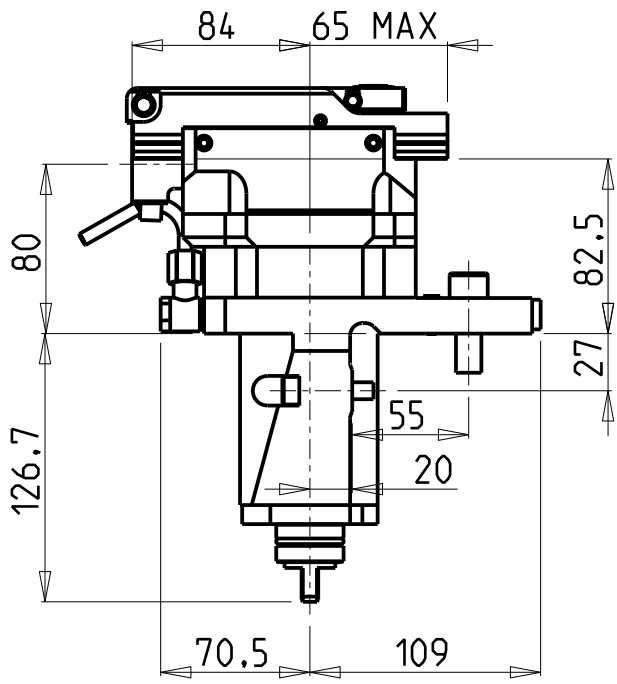

ATTENZIONE - ATTENTION - ACHTUNG

- VERIFICARE LE MISURE DI INGOMBRO PER POSSIBILE INTERFERENZA SU ALCUNI MODELLI DI MACCHINE
- Please check the overall sizes for possible interferences on some machine models
- Bitte überprüfen sie das ausmass um mögliche interferenzen auf einigen maschinen modellen zu vermeiden

PER UTENSILI STOZZATORI VEDI PAG. TBL400-1-00
 FOR DRIVEN SLOTTING TOOL CUTTING-TOOLS SEE PAGE TBL400-1-00
 FÜR NUTENSTOSS-WERKZEUG SCHNEIDWERKZEUGE SIEHE SEITE TBL400-1-00

Cod. MT	I	RPM MAX	Lubr. esterna Ext. coolant Aussenkuehlung
MSL0460200	4:1	2400	X

NEW

CMZ

MOD: TL25AM/AMS/BM/BMS - TL20M/MS/TM - TA15-20-25-30M/Y/MS/MY/YS - TC15-20-25-30-35M/Y/MS/MY/YS
 TD15-20-25-30-35-45-55M/Y/MS/MY/YS

MODULO MOTORIZZATO STOZZATORE CORSA 25mm H=80mm

Slotting driven tool 25mm stroke H=80mm

Keilnutenstossmaschine 25mm Hub H=80mm

Subject to change without notice.

M.T. srl
 Via Casino Albini 480
 Tel. 0541/956034-957884
 Fax 0541/956341
 47842 S. GIOVANNI IN M. (RN)
 e-mail: mtma@mtmarchetti.com
 http://www.mtmarchetti.com

PRODUZIONE MODULI ROTANTI



PAGINA CMZ360-2-01

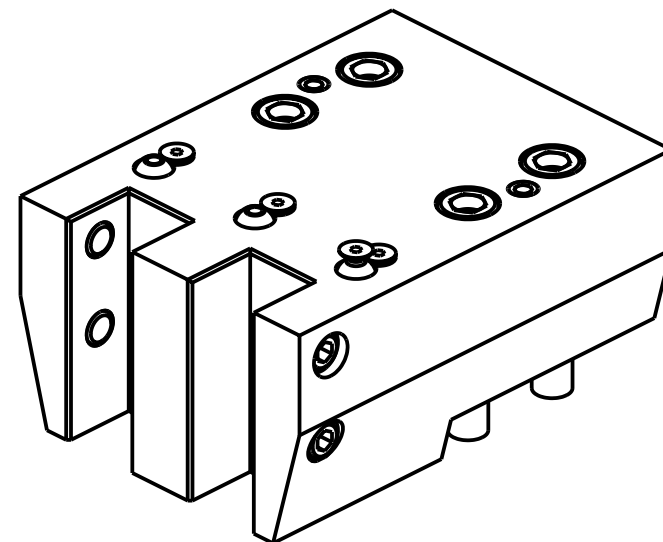
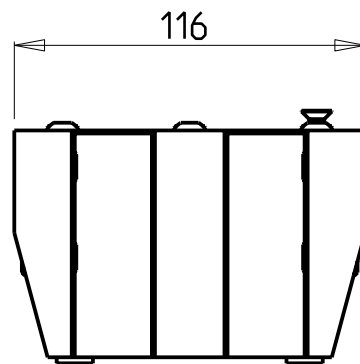
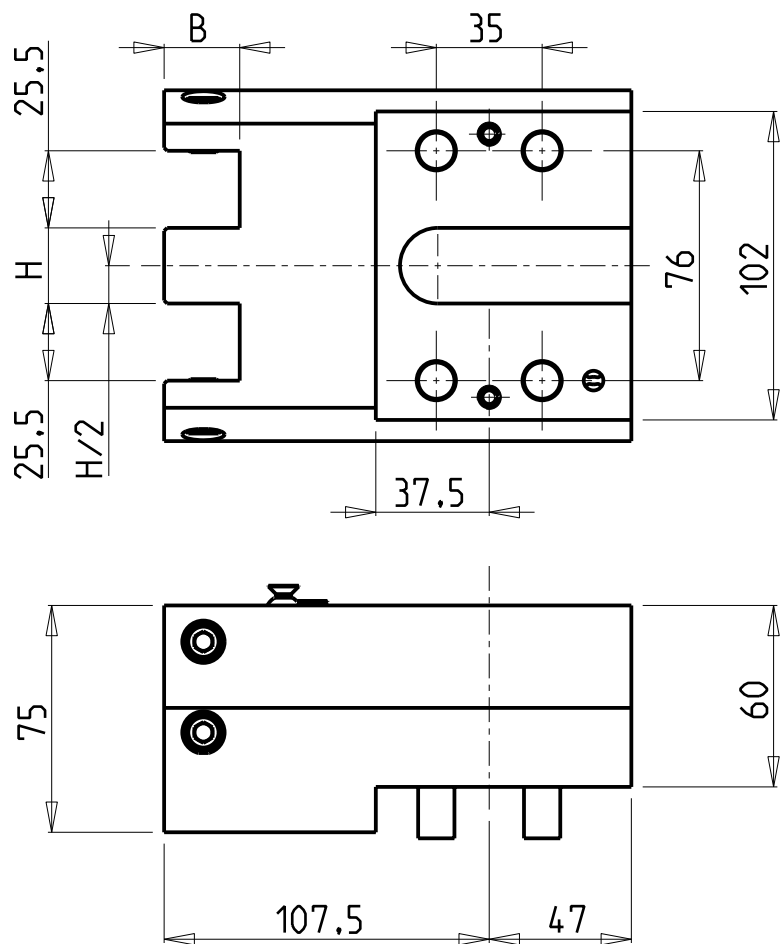

Cod. MT	Misure Dimensions Masse	H	B
MSL0342500	mm	25	25

CMZ

MOD:TA15-20-25-30M/Y/MS/MY/YS - TC15-20-25-30-35M/Y/MS/MY/YS - TD15-20-25-30-35-45-55M/Y/MS/MY/YS

PORTAUTENSILE RADIALE SOVRAPPOSTO QD=25mm

Radial single side twin static tool QD=25mm

Radial Werkzeughalter ueberlagert QD=25mm

Subject to change without notice.

M.T. srl

Via Casino Albini 480
Tel. 0541/956034-957884

Fax 0541/956341

47842 S. GIOVANNI IN M. (RN)

e-mail: mtma@mtmarchetti.com

http://www.mtmarchetti.com

PRODUZIONE MODULI ROTANTI



PAGINA CMZ440-2-00

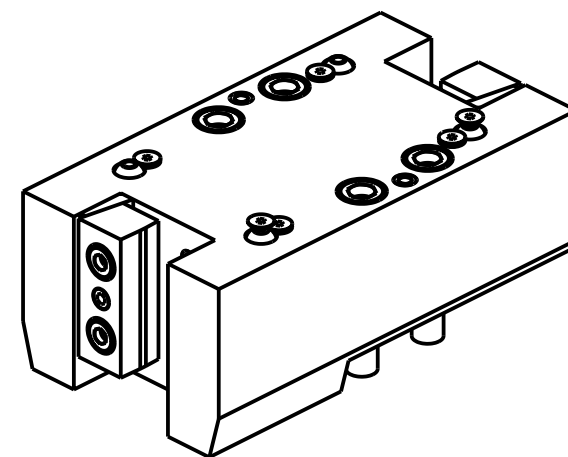
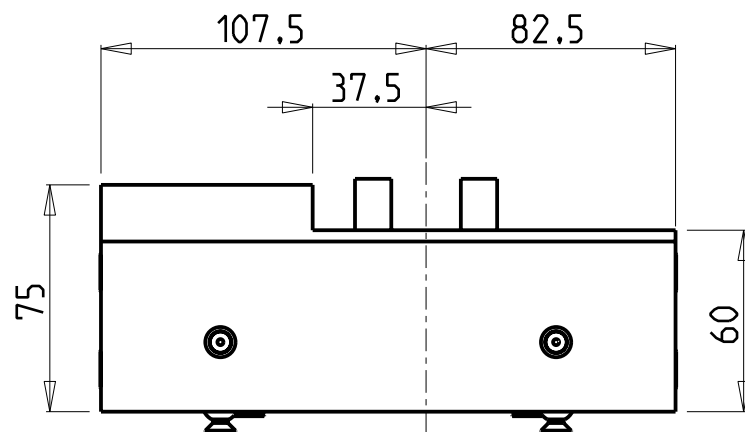
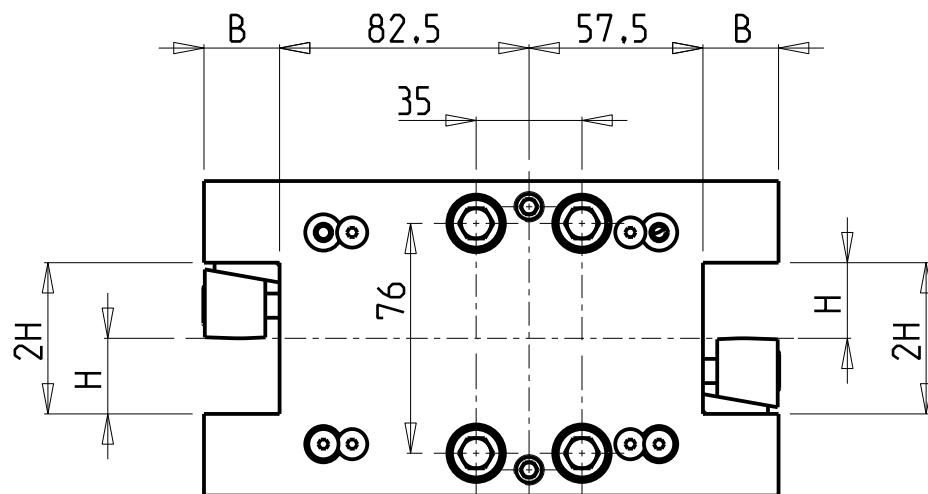
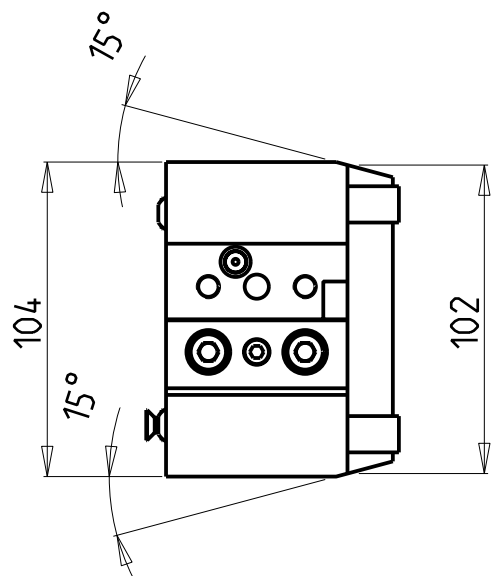

Cod. MT	N°Utensili N°Tools N°Werkzeuge	Misure Dimensions Masse	B	H
MSL0392500	2/4	mm	25	25

CMZ

MOD: TL25AM/AMS/BM/BMS - TL20M/MS/TM - TA15-20-25-30M/Y/MS/MY/YS - TC15-20-25-30-35M/Y/MS/MY/YS
 TD15-20-25-30-35-45-55M/Y/MS/MY/YS

PORTAUTENSILE RADIALE DOPPIO QD=25mm

Radial double static tool QD=25mm

Radial Doppel-Werkzeughalter QD=25mm

Subject to change without notice.

M.T. srl

Via Casino Albini 480
 Tel. 0541/956034-957884
 Fax 0541/956341

47842 S. GIOVANNI IN M. (RN)
 e-mail: mtma@mtmarchetti.com
 http://www.mtmarchetti.com

PRODUZIONE MODULI ROTANTI



PAGINA CMZ453-2-00

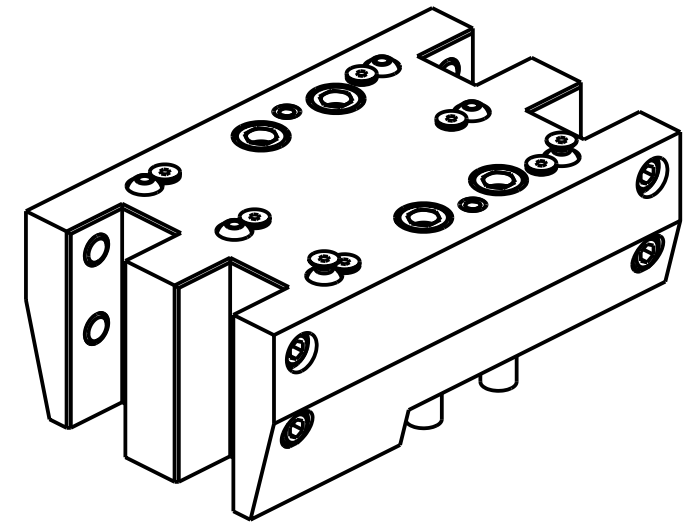
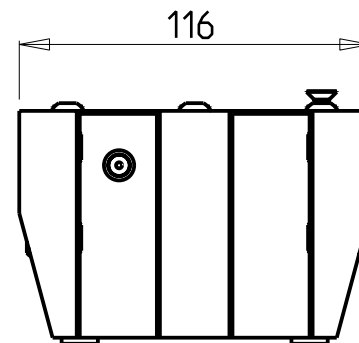
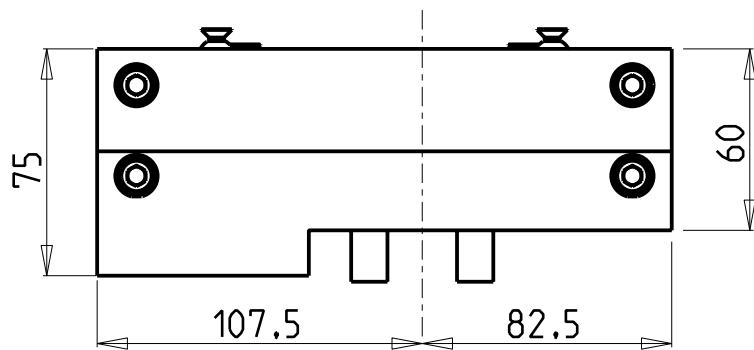
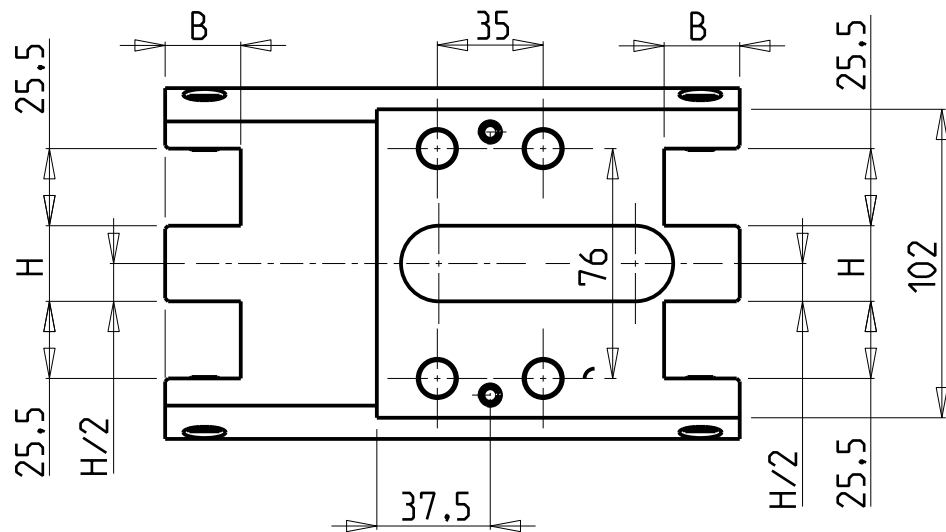

Cod. MT	Misure Dimensions Masse	H	B
MSL0332500	mm	25	25

CMZ

MOD:TA15-20-25-30YS - TC15-20-25-30-35YS - TD15-20-25-30-35-45-55YS

PORTAUTENSILE RADIALE DOPPIO SOVRAPPOSTO QD=25mm

Radial double side twin static tool QD=25mm

Radial Doppel-Werkzeughalter ueberlagert QD=25mm

Subject to change without notice.

M.T. srl

Via Casino Albini 480
Tel. 0541/956034-957884
Fax 0541/956341
47842 S. GIOVANNI IN M. (RN)
e-mail: mtma@mtmarchetti.com
<http://www.mtmarchetti.com>

PRODUZIONE MODULI ROTANTI



PAGINA CMZ460-2-00

10/2018

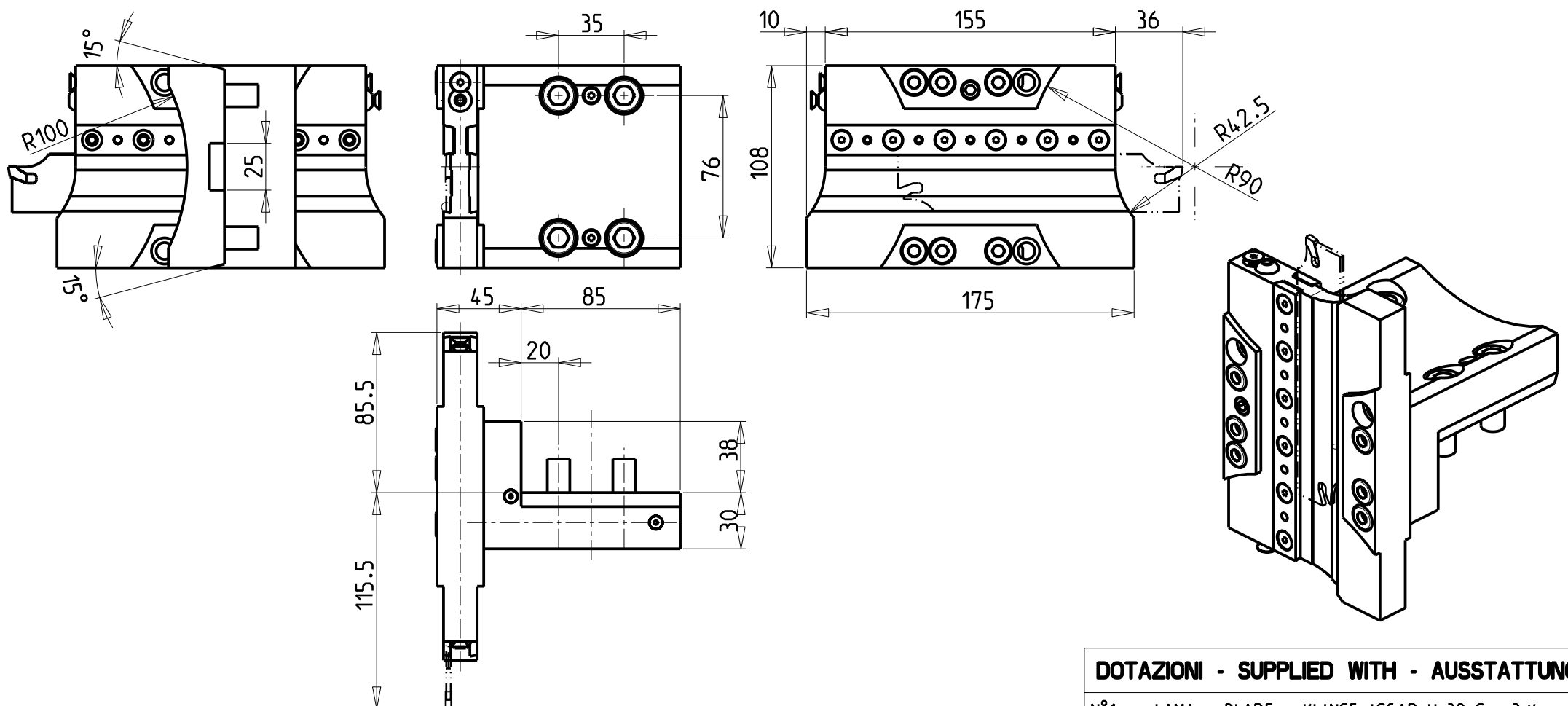

DOTAZIONI - SUPPLIED WITH - AUSSTATTUNG	
N°1	- LAMA - BLADE - KLINGE ISCAR H=32 Sp. 3/4mm (KENNAMETAL OPTIONAL)
N°10	- INSERTI - INSERTS - EINLAGEN
N°1	- CHIAVE A T PER MONTAGGIO INSERTI - T-WRENCH FOR INSERT SET UP - T-SCHLUESSEL FUER EINSATZSTUECK-MONTAGE

POSSIBILITA' DI LAVORO M3/M4
 OPTION OF. M3/M4 WORKING
 ARBEITSMOGLICHKEIT M3/M4

Cod. MT	N°Utensili N° Tools N° Werkzeuge
M0250132	1

CMZ MOD: TL25AM/AMS/BM/BMS - TL20M/MS/TM - TA15-20-25-30M/Y/MS/MY/YS - TC15-20-25-30-35M/Y/MS/MY/YS TD15-20-25-30-35-45-55M/Y/MS/MY/YS PORTAUTENSILE PER LAMA DOPPIO Radial double blade holder Radial Doppel-Abstechhalter	M.T. srl Via Casino Albini 480 Tel. 0541/956034-957884 Fax 0541/956341 47842 S. GIOVANNI IN M. (RN) e-mail: mtma@mtmarchetti.com http://www.mtmarchetti.com	PRODUZIONE MODULI ROTANTI  PAGINA CMZ520-2-00
---	---	--

Subject to change without notice.

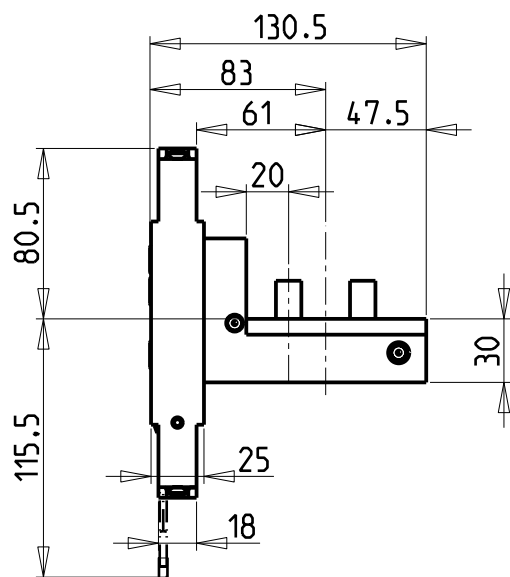
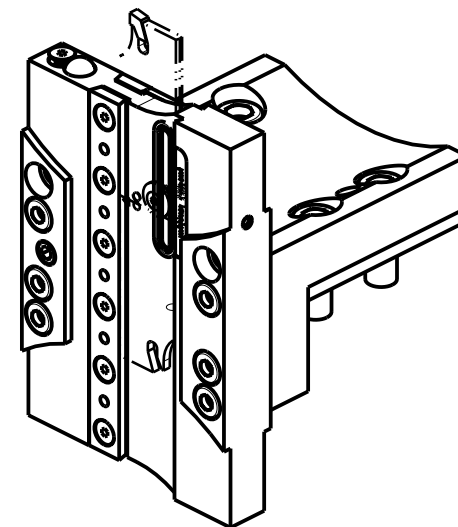
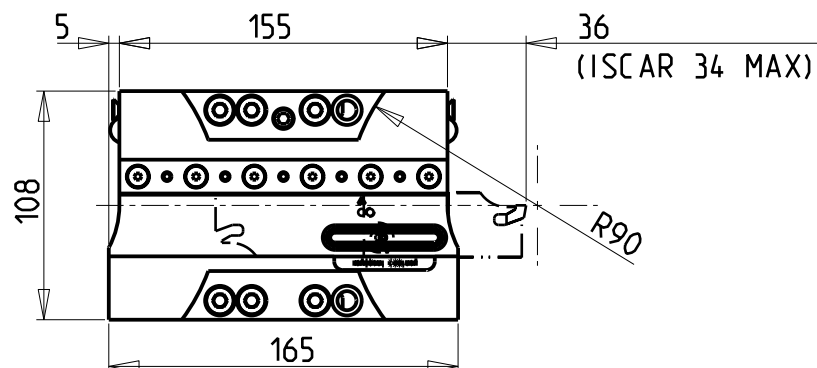
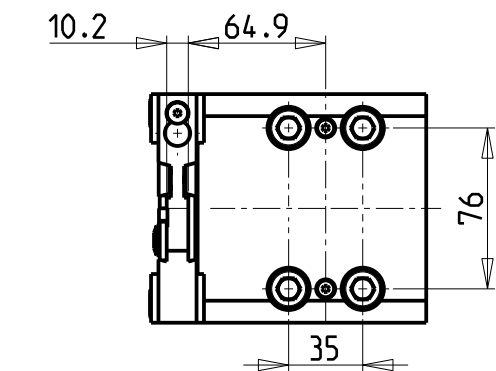

POSSIBILITA' DI LAVORO M3/M4
 OPTION OF M3/M4 WORKING
 ARBEITSMÖGLICHKEIT M3/M4

KIT LAME NON INCLUSI (OPZIONALI)
BLADES NOT SUPPLIED WITH (OPTIONAL)
KLINGEN NICHT INBEGRIFFEN (OPTIONAL)

- LAMA-BLADE-KLINGE SANDVIK H=32 sp.3 cod. QD_NN2G60C 25A
 +INSERTI-INSERTS-EINLAGEN cod. QD_NG_0300_0002_CM_1145 (10 pz.)
- LAMA-BLADE-KLINGE SANDVIK H=32 sp.4 cod. QD_NN2H60C 25A
 +INSERTI-INSERTS-EINLAGEN cod. QD_NH_0400_0002_CM_1145 (10 pz.)
- LAMA-BLADE-KLINGE ISCAR H=32 sp.3 cod. SGFH_32K_3
 +INSERTI-INSERTS-EINLAGEN cod. 6011365 (10pz.)
- LAMA-BLADE-KLINGE ISCAR H=32 sp.4 cod. SGFH_32K_4
 +INSERTI-INSERTS-EINLAGEN cod. 6011366 (10pz.)
- LAMA-BLADE-KLINGE WALTER H=32 sp.3 cod. G2042.32N-3T45SX-P
 +INSERTI-INSERTS-EINLAGEN cod. SX-3E300N02-CE4 WSM33S (10pz.) + CHIAVE-KEY cod. FS1494
- LAMA-BLADE-KLINGE WALTER H=32 sp.4 cod. G2042.32N-4T50SX-P
 +INSERTI-INSERTS-EINLAGEN cod. SX-4E400N02-CE4 WSM33S (10pz.) + CHIAVE-KEY cod. FS1494

Cod. MT	N°Utensili N°Tools N°Werkzeuge	Lubr.esterna Ext. coolant Aussenkuehlung	Lubr.interna Coolant through Innenkuehlung
MSL0220132	1	X	P=70bar

CMZ

MOD:TL25AM/AMS/BM/BMS - TL20M/MS/TM - TA15-20-25-30M/Y/MS/MY/YS - TC15-20-25-30-35M/Y/MS/MY/YS
 TD15-20-25-30-35-45-55M/Y/MS/MY/YS

PORTAUTENSILE PER LAMA DOPPIO CON LUBRIFICAZIONE INTERNA

Radial double blade holder with internal coolant

Radial Doppel-Abstechhalter mit Innenkuehlung

Subject to change without notice.

M.T. srl

Via Casino Albini 480
 Tel. 0541/956034-957884
 Fax 0541/956341
 47842 S. GIOVANNI IN M. (RN)
 e-mail: mtma@mtmarchetti.com
 http://www.mtmarchetti.com

PRODUZIONE MODULI ROTANTI



PAGINA CMZ520-2-04

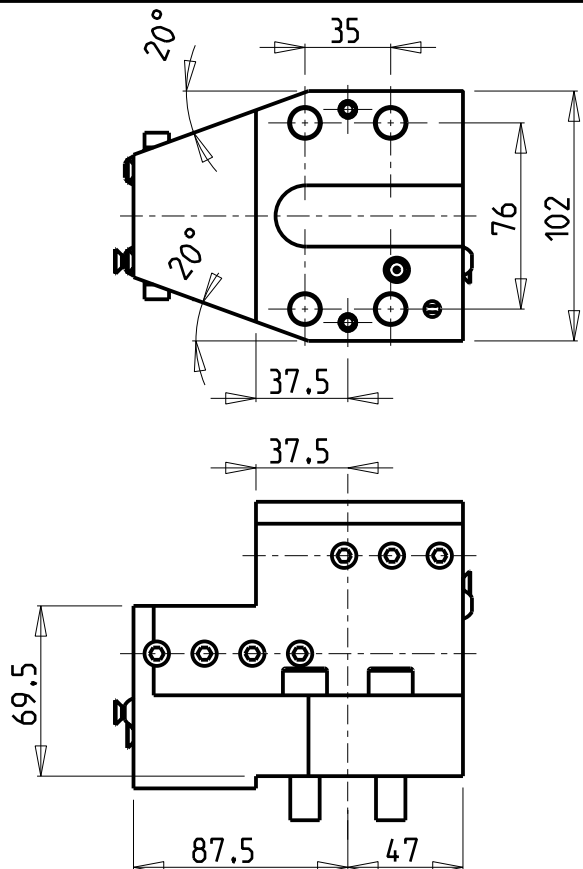

KIT ADDUZIONE INTERNA (OPZIONALE)
 KIT FOR INTERNAL COOLANT (OPTIONAL)
 KIT FUER INTERNE KUEHLMITTELZUFUHR (OPTIONAL)
 Ø32 cod. KIT1000001

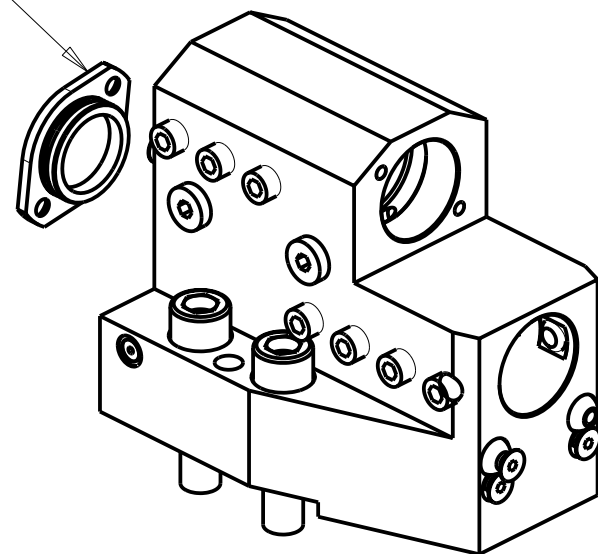

PER BOCCOLE DI RIDUZIONE VEDI PAG. TBL150-1-00
 FOR REDUCING BUSHINGS SEE PAGE TBL150-1-00
 FÜR REDUZIERBÜCHSE SIEHE SEITE TBL150-1-00

Cod. MT	Lubrificazione int. opzionale Coolant through optional Innenkuehlung Optional	Lubrificazione est. Ext. coolant Aussenkuehlung	Misure Dimensions Masse	D
MSL0353200	X	X	mm	32

CMZ

MOD: TA15-20-25-30M/Y/MS/MY/YS - TC15-20-25-30-35M/Y/MS/MY/YS - TD15-20-25-30-35-45-55M/Y/MS/MY/YS

PORTAUTENSILE ASSIALE PER BARENO 2 POSIZIONI Ø32mm

Axial double boring bar holder Ø32mm

Axial Bohrhälter 2 Positionen Ø32mm

Subject to change without notice.

M.T. srl

Via Casino Albini 480
 Tel. 0541/956034-957884
 Fax 0541/956341
 47842 S. GIOVANNI IN M. (RN)
 e-mail: mtma@mtmarchetti.com
 http://www.mtmarchetti.com

PRODUZIONE MODULI ROTANTI



PAGINA CMZ862-2-00

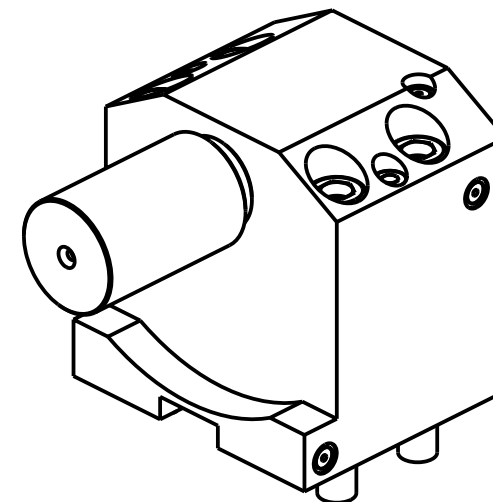
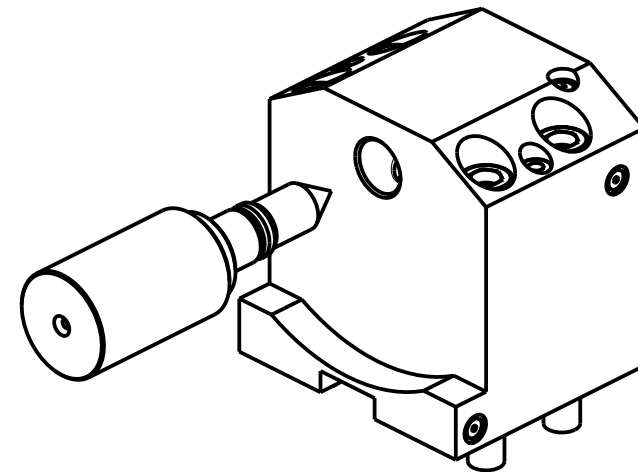
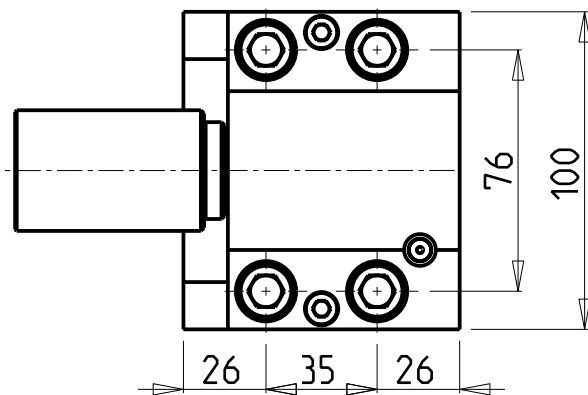
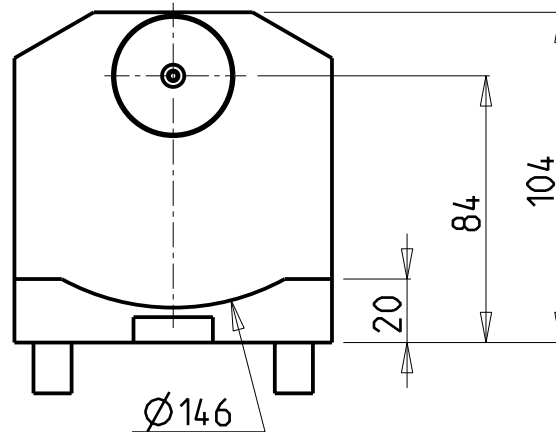
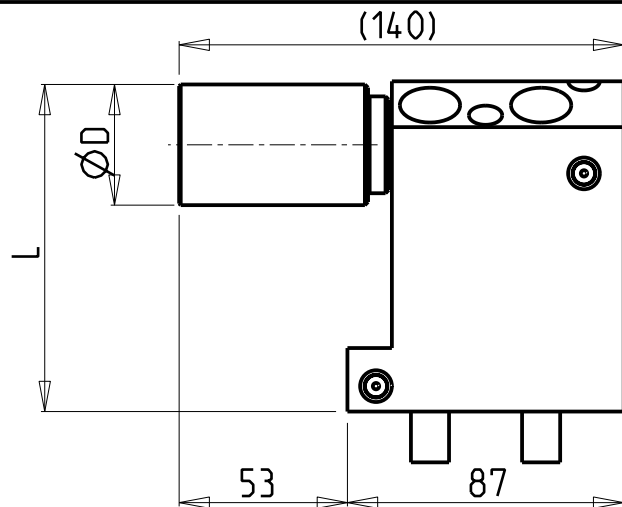

Cod. MT	N° Utensili N° Tools N° Werkzeuge	D	L
MSL0280100	1	38	103
MSL0280100L	1	2"	109.4

CMZ

MOD: TL25AM/AMS/BM/BMS - TL20M/MS/TM - TA15-20-25-30M/Y/MS/MY/YS - TC15-20-25-30-35M/Y/MS/MY/YS
TD15-20-25-30-35-45-55M/Y/MS/MY/YS

CONTROPUNTA PER CONTROMANDRINO

Tailstock for subspindle

Gegenspintz fuer Gegenspindel

Subject to change without notice.

M.T. srl

Via Casino Albini 480
Tel. 0541/956034-957884
Fax 0541/956341
47842 S. GIOVANNI IN M. (RN)
e-mail: mtma@mtmarchetti.com
http://www.mtmarchetti.com

PRODUZIONE MODULI ROTANTI



PAGINA CMZ950-2-00

10/2018

