

		PAGINA Page Seite
<p>MODULO MOTORIZZATO ASSIALE Axial driven tool Axial angetriebenes Werkzeug</p>		CTZ010.1.00
<p>MODULO MOTORIZZATO ASSIALE 2 USCITE IN Y MOLTIPLICATO 1=1:3 Axial geared-up 1=1:3 twin head driven tool in Y Axial angetriebenes Werkzeug 2 Ausgaenge in Y uebersetzt 1=1:3</p>		CTZ080.1.50
<p>MODULO MOTORIZZATO RADIALE Radial driven tool Radial angetriebenes Werkzeug</p>		CTZ150.1.10
<p>MODULO MOTORIZZATO ORIENTABILE 0-90° 0-90° adjustable angle driven tool Angetriebenes Werkzeug schwenkbar 0-90°</p>		CTZ330.1.00
<p>MODULO MOTORIZZATO TURBINATORE RIDOTTO 1=2:1 Driven whirling tool geared-down 1=2:1 Gewindewirbeleinrichtung untersetzt 1=2:1</p>		CTZ370.1.00

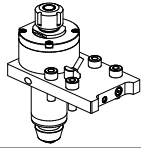

ATTENZIONE - ATTENTION - ACHTUNG

- Per lo smontaggio degli utensili utilizzare sempre la chiave di contrasto come indicato nel manuale d'uso.
- For disassembly of the tools use always the contrast key as mentioned in the user instructions.
- Fuer das Abmontieren der Werkzeuge immer den Gegenschlüssel benutzen wie in der Bedienungsanleitung erwaeht.

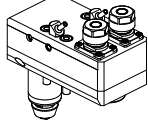
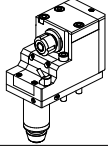
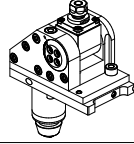
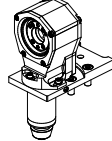
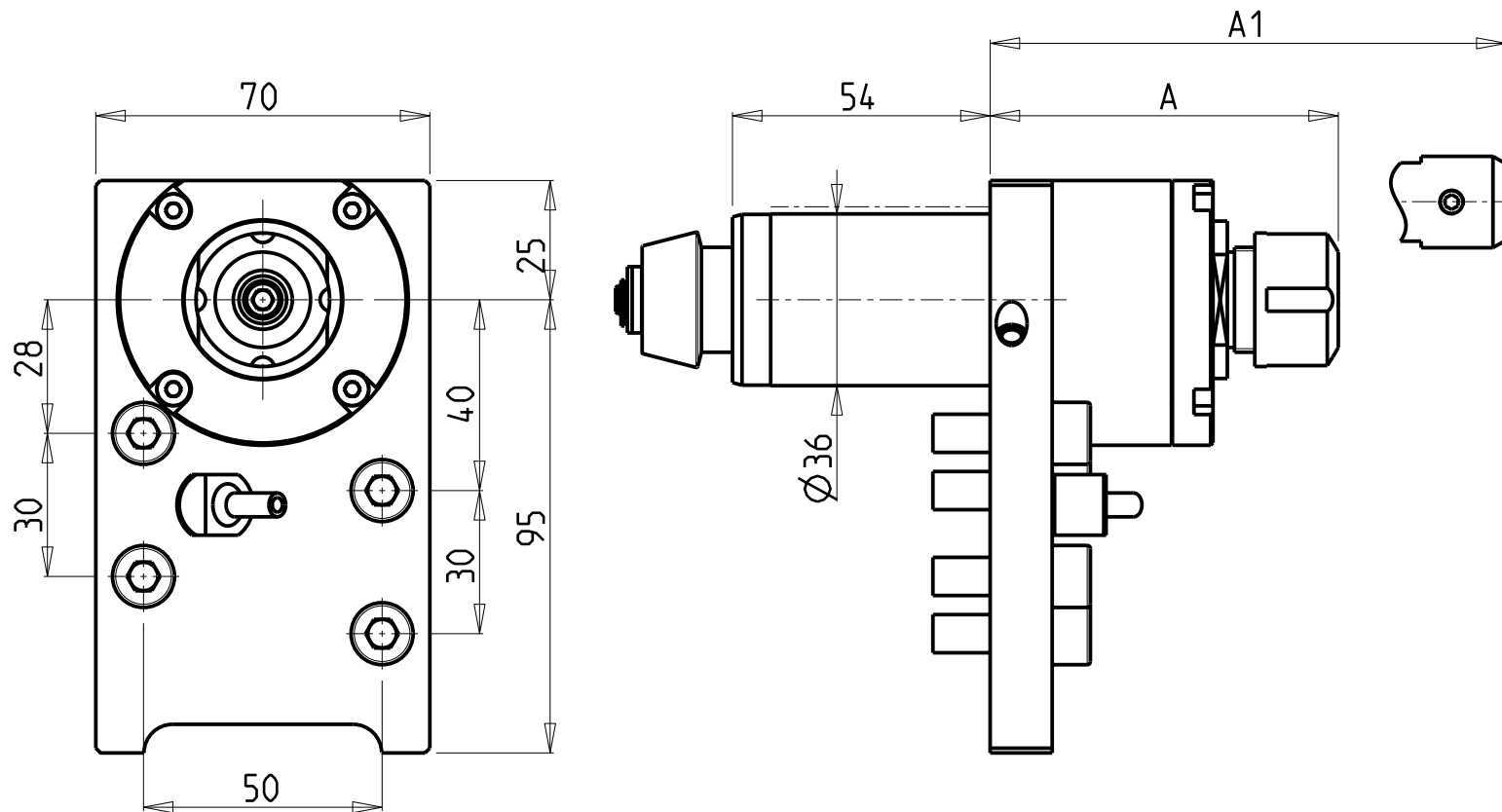
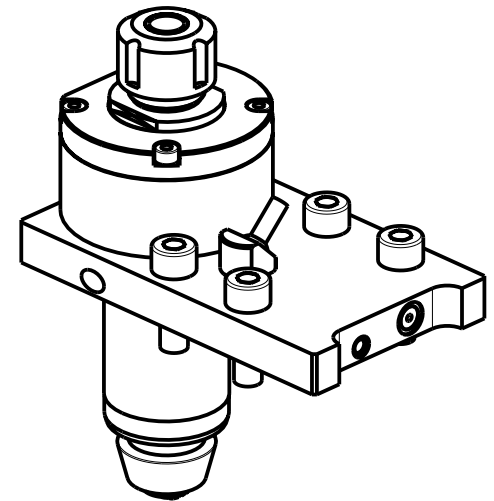

Cod. MT	Cod. CITIZEN	Mandrino Spindle Spindel	I	RPM	Reversibile lato mandrino/contromandrino Reversible sub/main spindle side Umkehrbare Spindelseite/ Gegenspindelseite	Lubr.interna Coolant through Innenkuehlung	Lubr.esterna Ext. coolant Aussenkuehlung	A	A1	CHIAVI INCLUDE Keys included Schluesssel inbegriffen	
CTZ0020116	KSC110MT	ER16	1:1	6000	X	-	X	73	-	CHSTER16	CHUB27_SP3
CTZ0020216	KSC110MTTC	ER16	1:1	6000	X	P=70bar	X	73	-	CHSTER16	CHUB27_SP3
CTZ0020710	-	WELDON 10	1:1	6000	X	-	X	-	62.7	-	-

CITIZEN
MOD: M20 - M32
MODULO MOTORIZZATO ASSIALE
 Axial driven tool
 Axial angetriebenes Werkzeug
 Subject to change without notice.

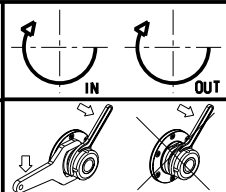

M.T. srl
 Via Casino Albini 480
 Tel. 0541/956034-957884
 Fax 0541/956341
 47842 S. GIOVANNI IN M. (RN)
 e-mail: mtma@mtmarchetti.com
 http://www.mtmarchetti.com

PRODUZIONE MODULI ROTANTI

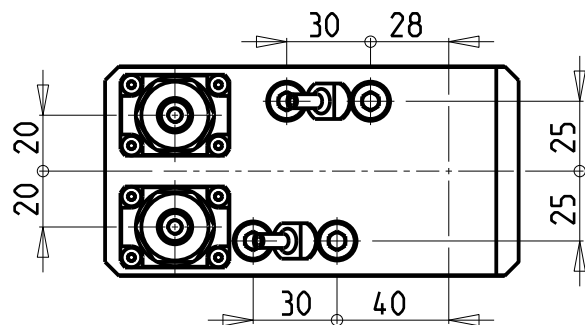
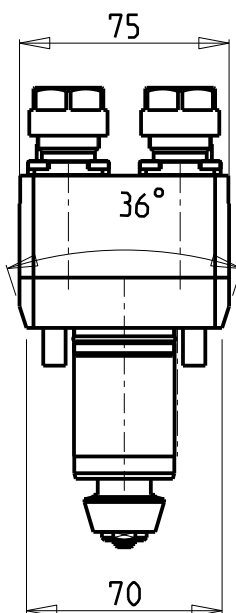
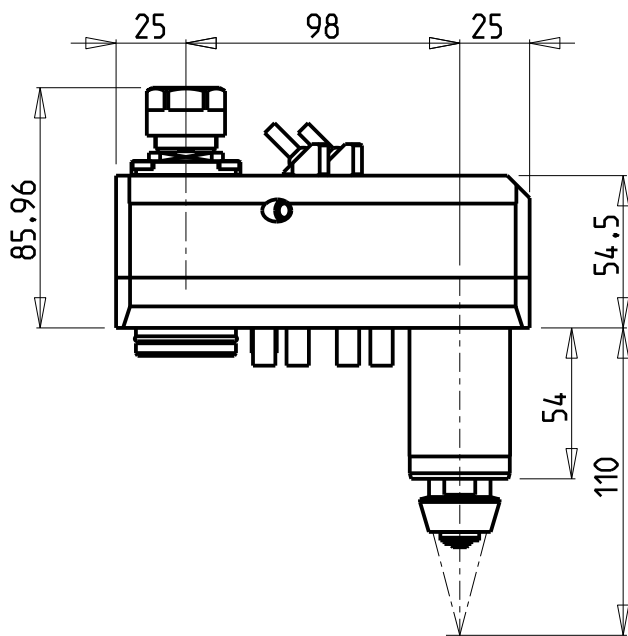
PAGINA CTZ010-1-00

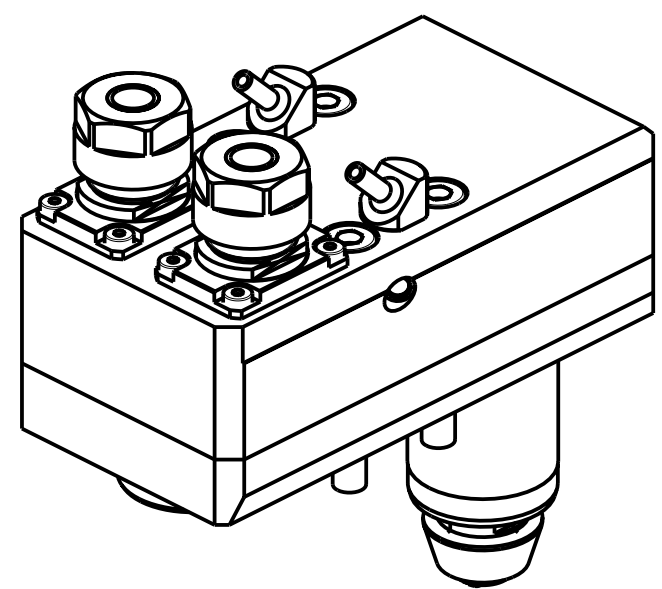

ATTENZIONE - ATTENTION - ACHTUNG

- Per lo smontaggio degli utensili utilizzare sempre la chiave di contrasto come indicato nel manuale d'uso.
- For disassembly of the tools use always the contrast key as mentioned in the user instructions.
- Fuer das Abmontieren der Werkzeuge immer den Gegenschlüssel benutzen wie in der Bedienungsanleitung erwaeht.



Cod. MT	Mandrino Spindle Spindel	I	RPM	Lubrificazione est. Ext. coolant Aussenkuehlung	Reversibile lato mandrino/contromandrino Reversible sub/main spindle side Umkehrbare Spindel-seite/ Gegenspindel-seite	CHIAVI INCLUSE Keys included Schluessel inbegriffen	
CTZ0050216	ER16	1:3	18000	X	X	CHUB19_SP3	CHUB25

CITIZEN
MOD: M20 - M32

MODULO MOTORIZZATO ASSIALE 2 USCITE IN Y MOLTIPLICATO I=1:3
 Axial geared-up I=1:3 twin head driven tool in Y
 Axial angetriebenes Werkzeug 2 Ausgaenge in Y uebersetzt I=1:3

Subject to change without notice.

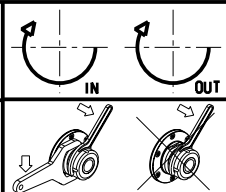

M.T. srl
 Via Casino Albini 480
 Tel. 0541/956034-957884
 Fax 0541/956341
 47842 S. GIOVANNI IN M. (RN)
 e-mail: mtma@mtmarchetti.com
 http://www.mtmarchetti.com

PRODUZIONE MODULI ROTANTI

PAGINA CTZ080-1-50

ATTENZIONE - ATTENTION - ACHTUNG

- Per lo smontaggio degli utensili utilizzare sempre la chiave di contrasto come indicato nel manuale d'uso.
- For disassembly of the tools use always the contrast key as mentioned in the user instructions.
- Fuer das Abmontieren der Werkzeuge immer den Gegenschlüssel benutzen wie in der Bedienungsanleitung erwaeht.

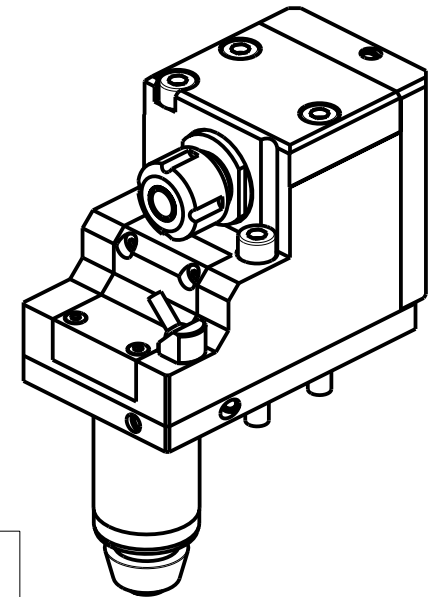
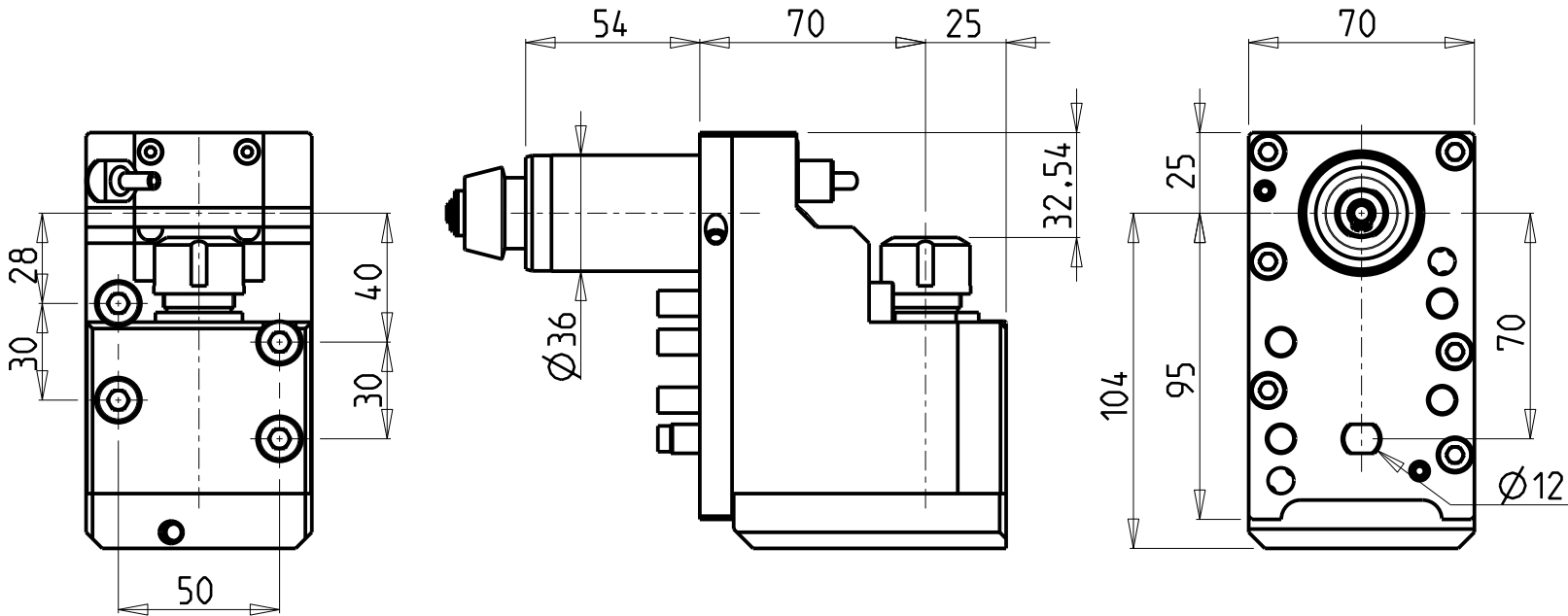

Cod. MT	Cod. CITIZEN	Mandrino Spindle Spindel	I	RPM	Reversibile lato mandrino/contromandrino Reversible sub/main spindle side Umkehrbare Spindel-seite/ Gegenspindel-seite	Lubr.interna Coolant through Innenkuehlung	Lubr.esterna Ext. coolant Aussenkuehlung	CHIAVI INCLUSE Keys included Schluesel inbegriffen	
CTZ0010116	KSE210MT	ER16	1:1	6000	X		X	CHSTER16	CHUB27_SP3
CTZ0010216	KSE210MTTC	ER16	1:1	6000	X	P=70bar	X	CHSTER16	CHUB27_SP3

CITIZEN
MOD: M20 - M32

MODULO MOTORIZZATO RADIALE
Radial driven tool
Radial angetriebenes Werkzeug

Subject to change without notice.

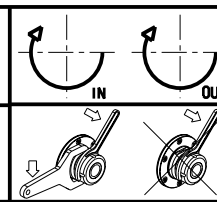

M.T. srl
Via Casino Albini 480
Tel. 0541/956034-957884
Fax 0541/956341
47842 S. GIOVANNI IN M. (RN)
e-mail: mtma@mtmarchetti.com
http://www.mtmarchetti.com

PRODUZIONE MODULI ROTANTI



PAGINA CTZ150-1-10

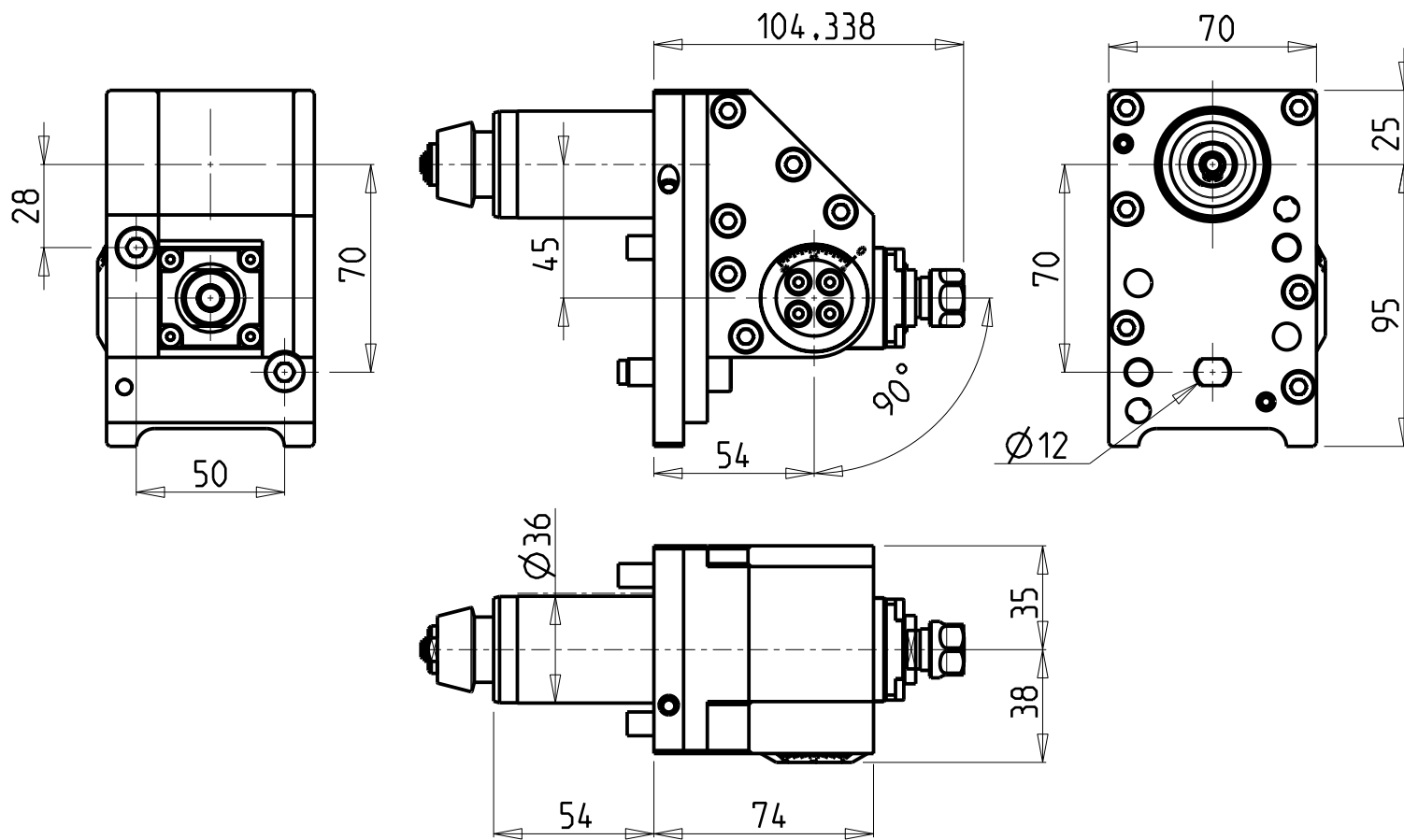

ATTENZIONE - ATTENTION - ACHTUNG

- Per lo smontaggio degli utensili utilizzare sempre la chiave di contrasto come indicato nel manuale d'uso.
- For disassembly of the tools use always the contrast key as mentioned in the user instructions.
- Fuer das Abmontieren der Werkzeuge immer den Gegenschlüssel benutzen wie in der Bedienungsanleitung erwaeht.

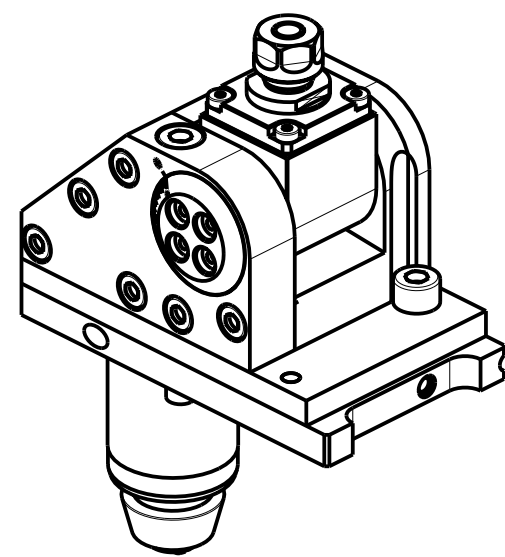

Cod. MT	Cod. CITIZEN	Mandrino Spindle Spindel	I	RPM	Reversibile lato mandrino/contromandrino Reversible sub/main spindle side Umkehrbare Spindel-seite/ Gegenspindel-seite	Lubrificazione est. Ext. coolant Aussenkuehlung	CHIAVI INCLUSE Keys included Schluessel inbegriffen
CTZ003011	KSA107MT	ER11	1:1	6000	X	X	CHUB19_SP3 CHUB17

CITIZEN
MOD: M20 - M32

MODULO MOTORIZZATO ORIENTABILE 0-90°
0-90° adjustable angle driven tool
Angetriebenes Werkzeug schwenkbar 0-90°

Subject to change without notice.

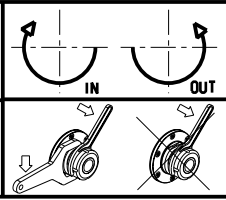

M.T. srl
Via Casino Albini 480
Tel. 0541/956034-957884
Fax 0541/956341
47842 S. GIOVANNI IN M. (RN)
e-mail: mtma@mtmarchetti.com
http://www.mtmarchetti.com

PRODUZIONE MODULI ROTANTI



PAGINA CTZ330-1-00

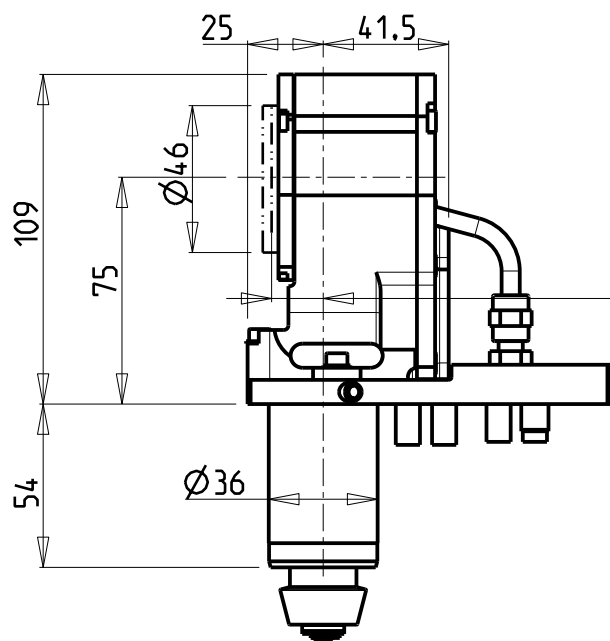
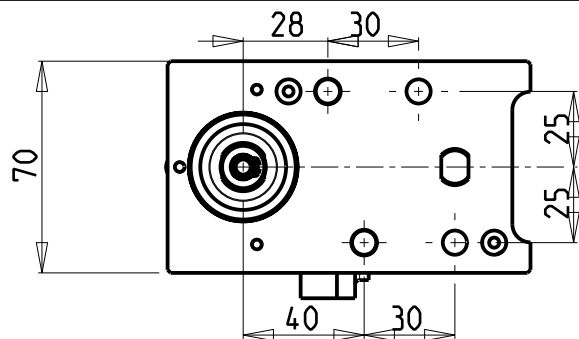

22
 Piano Inserti
 Inserts Surface
 Einsetze Flaechе

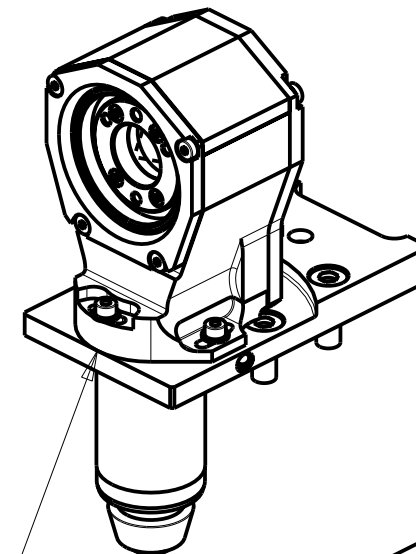
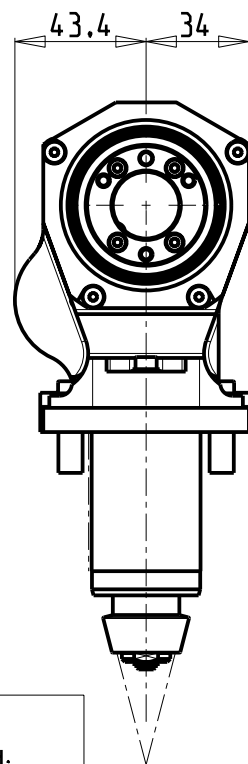

INCLINAZIONE
 REGOLABILE ±15°

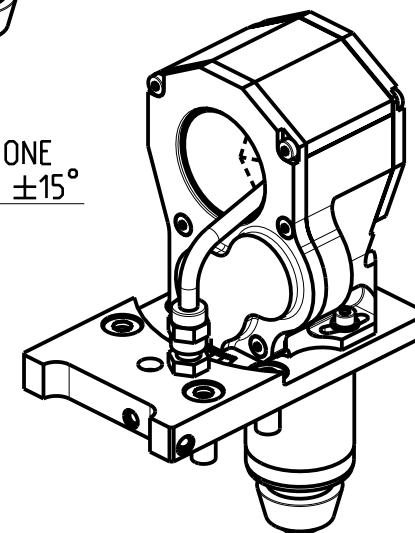

Cod. MT	I	RPM	Lubrificazione est. Ext. coolant Aussenkuehlung
CTZ0040112	2:1	3000	X

Fresa non inclusa:
 Milling-cutter not included:
 Fraese nicht inbegriffen:
 SANDVIK Coromill 325 cod. 325-12AP40-16M

CITIZEN
 MOD: M20 - M32

MODULO MOTORIZZATO TURBINATORE RIDOTTO I=2:1
 Driven whirling tool geared-down I=2:1
 Gewindewirbeleinrichtung untersetzt I=2:1

Subject to change without notice.

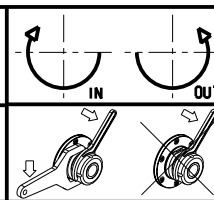

M.T. srl
 Via Casino Albini 480
 Tel. 0541/956034-957884
 Fax 0541/956341
 47842 S. GIOVANNI IN M. (RN)
 e-mail: mtma@mtmarchetti.com
 http://www.mtmarchetti.com

PRODUZIONE MODULI ROTANTI



PAGINA CTZ370-1-00

