

		PAGINA Page Seite
<b>MODULO MOTORIZZATO ASSIALE VDI30</b> Axial driven tool VDI30 Axial angetriebenes Werkzeug VDI30		BAR014.1.00
<b>MODULO MOTORIZZATO RADIALE VDI30</b> Radial driven tool VDI30 Radial angetriebenes Werkzeug VDI30		BAR015.1.00
<b>MODULO MOTORIZZATO RADIALE ARRETRATO VDI30 H=75mm</b> Radial rear-set driven tool VDI30 H=75mm Radial angetriebenes Werkzeug zurueckversetzt VDI30 H=75mm		BAR015.1.60
<b>MODULO MOTORIZZATO RADIALE ARRETRATO MTSK VDI30 H=75mm</b> Radial MTSK rear-set driven tool VDI30 H=75mm Radial MTSK angetriebenes Werkzeug zurueckversetzt VDI30 H=75mm		BAR015.1.60.K
<b>MODULO MOTORIZZATO RADIALE ARRETRATO VDI30 H=85mm</b> Radial rear-set driven tool VDI30 H=85mm Radial angetriebenes Werkzeug zurueckversetzt VDI30 H=85mm		BAR015.1.70
<b>MODULO MOTORIZZATO RADIALE ARRETRATO MTSK VDI30 H=85mm</b> Radial MTSK rear-set driven tool VDI30 H=85mm Radial MTSK angetriebenes Werkzeug zurueckversetzt VDI30 H=85mm		BAR015.1.70.K

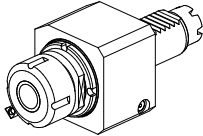

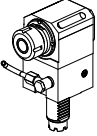
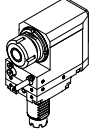
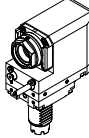
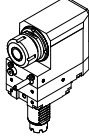
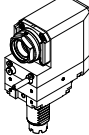
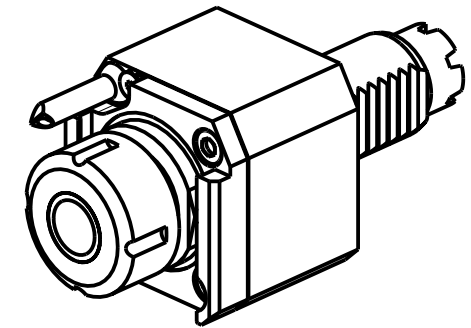
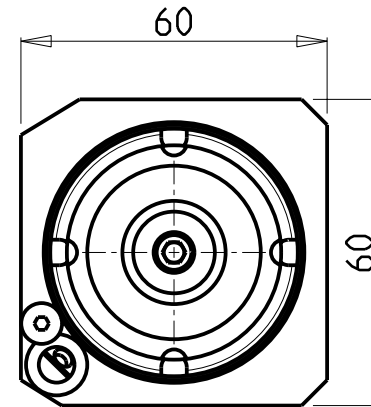
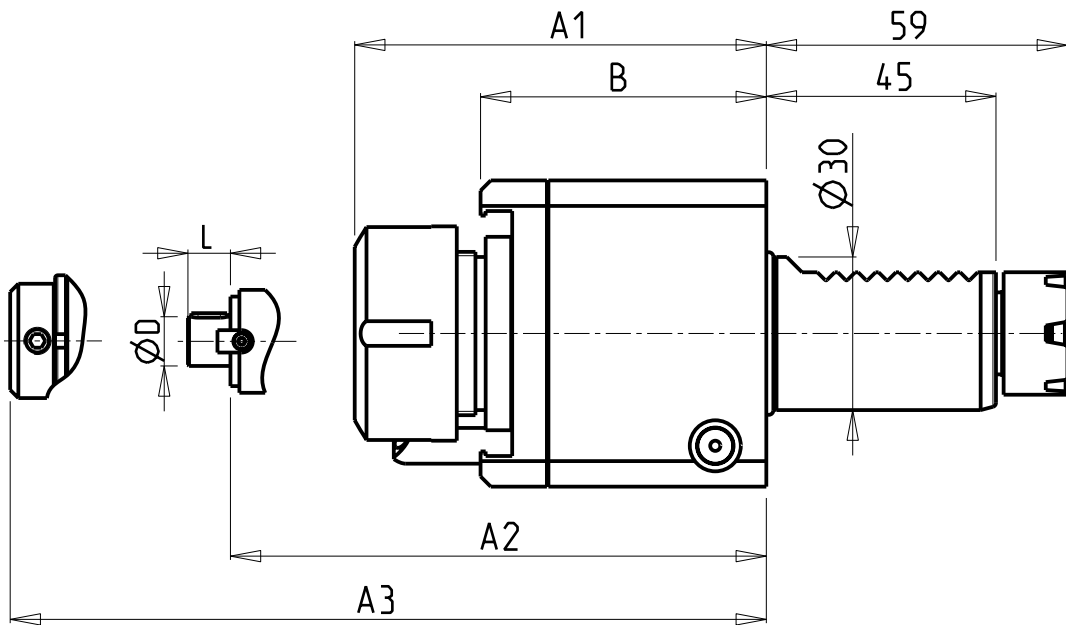

- Chiave inclusa
- Key included
- Schlüssel inbegriffen

Cod. MT	Mandrino Spindle Spindel	I	RPM	Coppia Max Max Torque Max Drehmoment	Lubrificazione int. Coolant through Innenkuehlung	Lubrificazione est. Ext. coolant Aussenkuehlung	ØD	L	A1	A2	A3	B	CHIAVI NON INCLUDE Keys not included Schlüssel nicht einbegriffen				
BAR0040125	ER25	1:1	6000	32Nm		X		80.66				56	-	CHSTER25	OKU0290009	•	
BAR0041125	ER25	1:1	6000	32Nm	P=30bar	X		94.66				70	-	CHSTER25	OKU0290009	•	
BAR0040225	ERA25	1:1	6000	32Nm		X		61				56	CHUB27	CHTAER25ZC	•	OKU0290009	•
BAR0041225	ERA25	1:1	6000	32Nm	P=30bar	X		75				70	CHUB27	CHTAER25ZC	•	OKU0290009	•
BAR0040316	WELDON16	1:1	6000	32Nm		X					66.5	56	-	-	-	-	
BAR0041316	WELDON16	1:1	6000	32Nm	P=30bar	X					80	70	-	-	-	-	
BAR0040416	Ø16x17	1:1	6000	32Nm		X	16	17		59.5		56	-	CH_VTCROCE_M08	•	OKU0290009	•
BAR0040422	Ø22x19	1:1	6000	32Nm		X	22	19		61.5		56	-	CH_VTCROCE_M10	•	OKU0290009	•

BARUFFALDI  
VDI 30

MODULO MOTORIZZATO ASSIALE VDI30  
Axial driven tool VDI30  
Axial angetriebenes Werkzeug VDI30

Subject to change without notice.

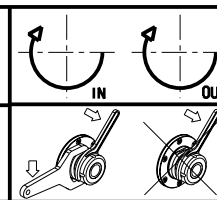

**M.T. srl**  
Via Casino Albini 480  
Tel. 0541/956034-957884  
Fax 0541/956341  
47842 S. GIOVANNI IN M. (RN)  
e-mail: mtma@mtmarchetti.com  
http://www.mtmarchetti.com

PRODUZIONE MODULI ROTANTI



PAGINA BAR014-1-00

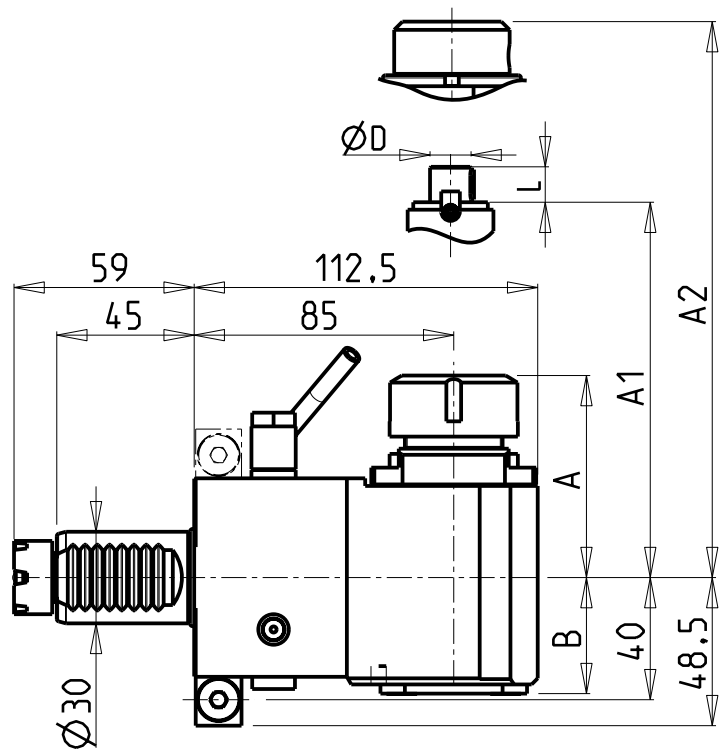

versione dx  
right version  
version rechts

versione sx  
left version  
version links

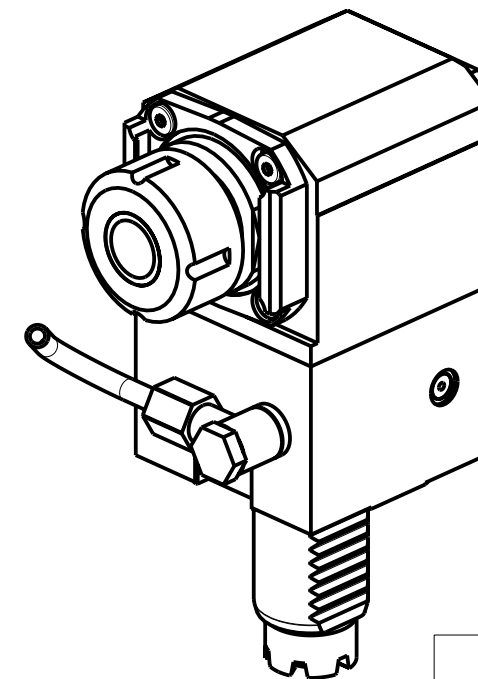
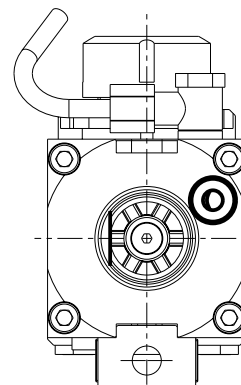
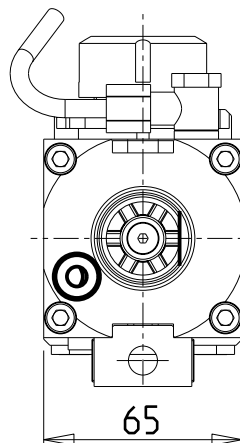

- Chiave inclusa
- Key included
- Schlüssel inbegriffen

Cod. MT		Mandrino Spindle Spindel	I	RPM	Coppia Max Max Torque Max Drehmoment	Lubrificazione int. Coolant through Innenkuehlung	Lubrificazione est. Ext. coolant Aussenkuehlung	ØD	L	A	A1	A2	B	CHIAVI NON INCLUDE Keys not included Schlüssel nicht einbegriffen	
versione dx right version version rechts	versione sx left version version links														
BAR0060125	BAR0061125	ER25	1:1	6000	32Nm	-	X	-	-	66.2	-	-	38	OKU0290009 ▪	CHSTER25
BAR0060225	BAR0061225	ER25	1:1	6000	32Nm	P=70bar	X	-	-	66.2	-	-	48	OKU0290009 ▪	CHSTER25
BAR0060316	BAR0061316	WELDON16	1:1	6000	32Nm	-	X	-	-	-	-	54.5	38	-	-
BAR0060416	BAR0061416	Ø16x17	1:1	6000	32Nm	-	X	16	17	-	45	-	38	OKU0290009 ▪	CH_VTCROCE_M08 ▪
BAR0060422	BAR0061422	Ø22x19	1:1	6000	32Nm	-	X	22	19	-	47	-	38	OKU0290009 ▪	CH_VTCROCE_M10 ▪

BARUFFALDI  
VDI 30

MODULO MOTORIZZATO RADIALE VDI30  
Radial driven tool VDI30  
Radial angetriebenes Werkzeug VDI30

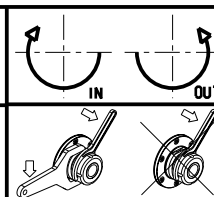

**M.T. srl**

Via Casino Albini 480  
Tel. 0541/956034-957884  
Fax 0541/956341  
47842 S. GIOVANNI IN M. (RN)  
e-mail: mtma@mtmarchetti.com  
http://www.mtmarchetti.com

PRODUZIONE MODULI ROTANTI



PAGINA BAR015-1-00

Subject to change without notice.

10/2018

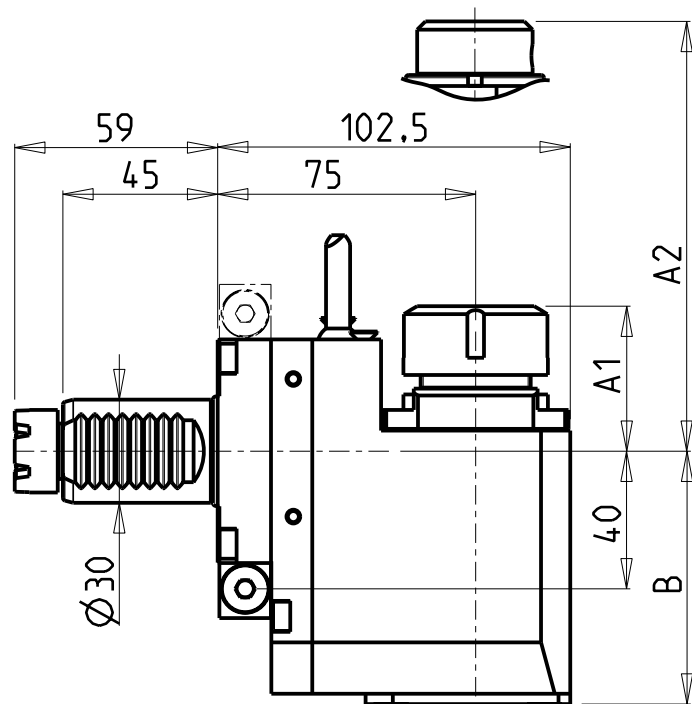

versione dx  
right version  
version rechts

versione sx  
left version  
version links

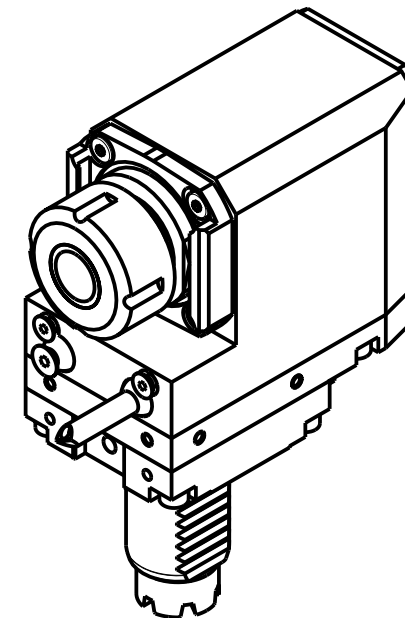
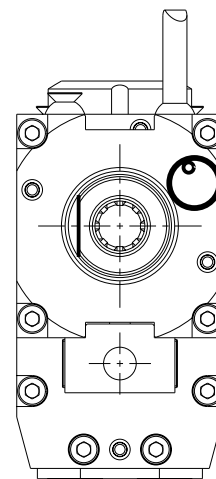
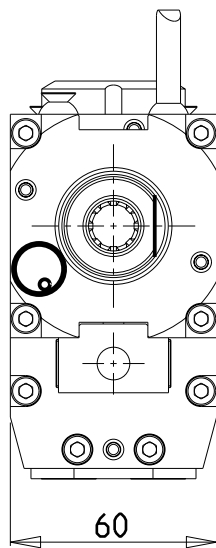

Cod. MT		Mandrino Spindle Spindel	I	RPM	Coppia Max Max Torque Max Drehmoment	Lubrificazione int. Coolant through Innenkuehlung	Lubrificazione est. Ext. coolant Aussenkuehlung	A1	A2	B	CHIAVI NON INCLUDE Keys not included Schluessel nicht einbegriffen	
versione dx right version version rechts	versione sx left version version links											
BAR0080120	BAR0081120	ER20	1:1	6000	32Nm		X	41.16	73.5	-	CHSTER20 OKU0290009	
BAR0080320	BAR0081320	ERA20	1:1	6000	32Nm		X	24.5	73.5	CHUB22	CHTAER20ZC OKU0290009	
BAR0080420	BAR0081420	ERA20	1:1	6000	32Nm	P=70bar	X	24.5	83.5	CHUB22	CHTAER20ZC OKU0290009	
BAR0080125	BAR0081125	ER25	1:1	6000	32Nm		X	42.16	73.5	-	CHSTER25 OKU0290009	
BAR0080225	BAR0081225	ER25	1:1	6000	32Nm	P=70bar	X	42.16	83.5	-	CHSTER25 OKU0290009	
BAR0080325	BAR0081325	ERA25	1:1	6000	32Nm		X	28.5	73.5	CHUB27	CHTAER25ZC OKU0290009	
BAR0080425	BAR0081425	ERA25	1:1	6000	32Nm	P=70bar	X	28.5	83.5	CHUB27	CHTAER25ZC OKU0290009	
BAR0080516	BAR0081516	WELDON16	1:1	6000	32Nm		X		27.5	73.5	-	-

- Chiave inclusa
- Key included
- Schluessel inbegriffen

BARUFFALDI  
VDI 30

MODULO MOTORIZZATO RADIALE ARRETRATO VDI30 H=75mm  
Radial rear-set driven tool VDI30 H=75mm  
Radial angetriebenes Werkzeug zurueckversetzt VDI30 H=75mm

Subject to change without notice.

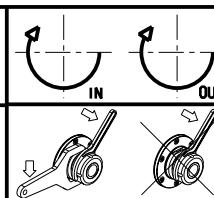

**M.T. srl**

Via Casino Albini 480  
Tel. 0541/956034-957884  
Fax 0541/956341  
47842 S. GIOVANNI IN M. (RN)  
e-mail: mtma@mtmarchetti.com  
http://www.mtmarchetti.com

PRODUZIONE MODULI ROTANTI



PAGINA BAR015-1-60

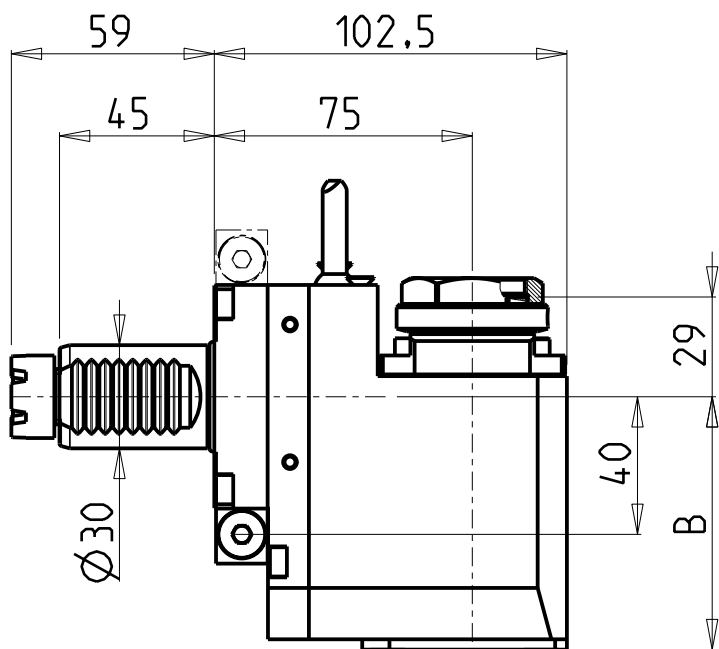

versione dx  
right version  
version rechts

versione sx  
left version  
version links

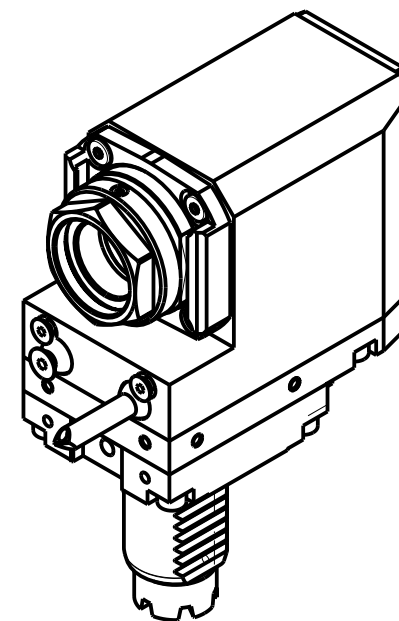
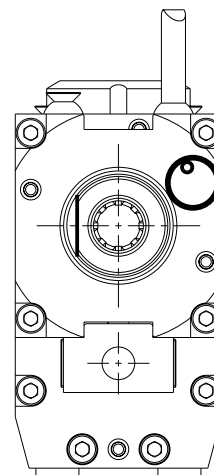
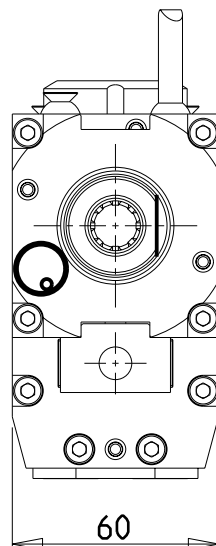

PER PORTAUTENSILI MODULARI MTSK-32 VEDI PAG. TBL300-1-32  
FOR MTSK-32 QUICK CHANGE TOOLHOLDERS CLAMPINGS SEE PAGE TBL300-1-32  
FUER MTSK-32 MODULARE WERKZEUGAUFNAHMEN SIEHE SEITE TBL300-1-32

- Chiave inclusa
- Key included
- Schlüssel inbegriffen

Cod. MT		Mandrino Spindle Spindel	i	RPM	Coppia Max Max Torque Max Drehmoment	Lubrificazione int. Coolant through Innenkuehlung	Lubrificazione est. Ext. coolant Aussenkuehlung	B	CHIAVI NON INCLUSE Keys not included Schlüssel nicht einbegriffen	
versione dx right version version rechts	versione sx left version version links								C HUB36	OKU0290009 ■
BAR0170132	BAR0171132	MTSK-32	1:1	6000	32Nm	-	X	73.5	C HUB36	OKU0290009 ■
BAR0170232	BAR0171232	MTSK-32	1:1	6000	32Nm	P=70bar	X	83.5	C HUB36	OKU0290009 ■

BARUFFALDI  
VDI 30

MODULO MOTORIZZATO RADIALE ARRETRATO MTSK VDI30 H=75mm  
Radial MTSK rear-set driven tool VDI30 H=75mm  
Radial MTSK angetriebenes Werkzeug zurueckversetzt VDI30 H=75mm

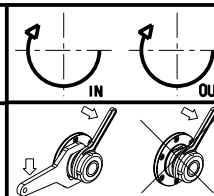

**M.T. srl**  
Via Casino Albini 480  
Tel. 0541/956034-957884  
Fax 0541/956341  
47842 S. GIOVANNI IN M. (RN)  
e-mail: mtma@mtmarchetti.com  
http://www.mtmarchetti.com

PRODUZIONE MODULI ROTANTI



PAGINA BAR015-1-60-K

Subject to change without notice.

10/2018

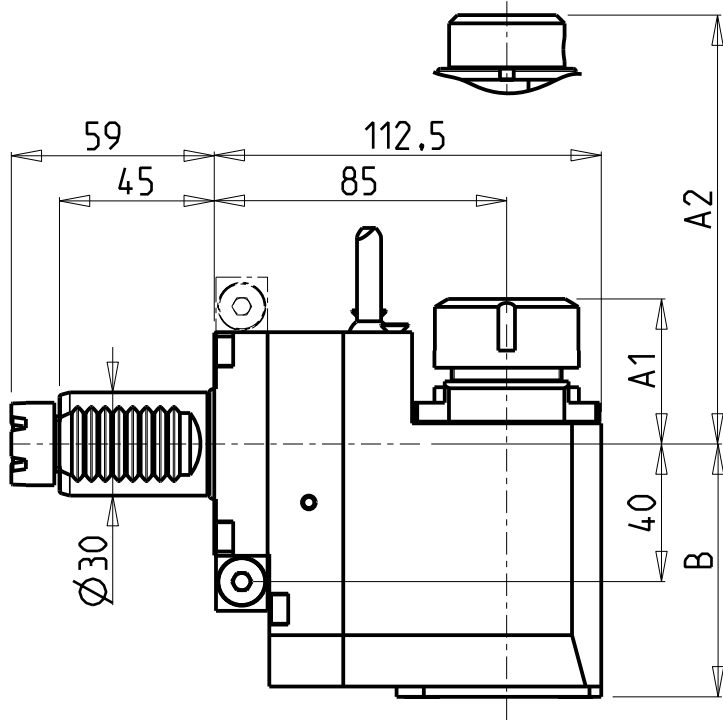

versione dx  
right version  
version rechts

versione sx  
left version  
version links

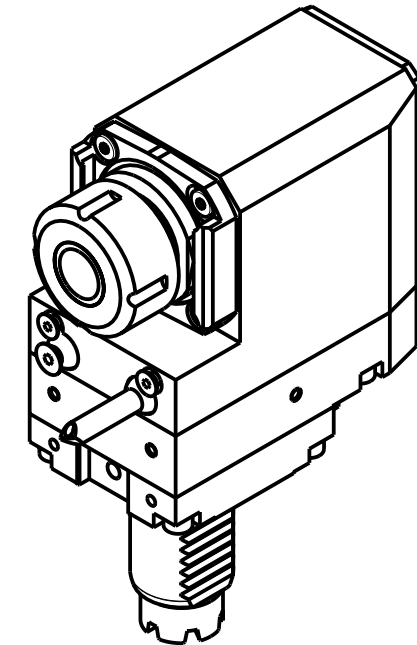
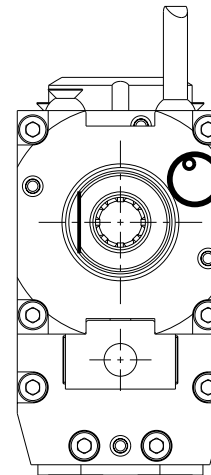
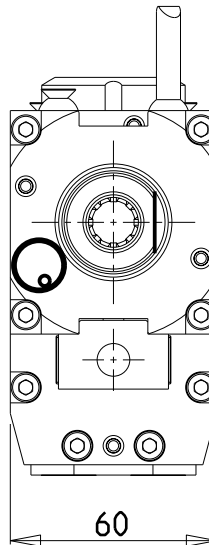

Cod. MT		Mandrino Spindle Spindel	I	RPM	Coppia Max Max Torque Max Drehmoment	Lubrificazione int. Coolant through Innenkuehlung	Lubrificazione est. Ext. coolant Aussenkuehlung	A1	A2	B	CHIAVI NON INCLUDE Keys not included Schluessel nicht einbegriffen		
versione dx right version version rechts	versione sx left version version links												
BAR0070120	BAR0071120	ER20	1:1	6000	32Nm		X	41.16	73.5	-	CHSTER20	OKU0290009 ■	
BAR0070320	BAR0071320	ERA20	1:1	6000	32Nm		X	24.5	73.5	CHUB22	CHTAER20ZC ■	OKU0290009 ■	
BAR0070420	BAR0071420	ERA20	1:1	6000	32Nm	P=70bar	X	24.5	83.5	CHUB22	CHTAER20ZC ■	OKU0290009 ■	
BAR0070125	BAR0071125	ER25	1:1	6000	32Nm		X	42.16	73.5	-	CHSTER25	OKU0290009 ■	
BAR0070225	BAR0071225	ER25	1:1	6000	32Nm	P=70bar	X	42.16	83.5	-	CHSTER25	OKU0290009 ■	
BAR0070325	BAR0071325	ERA25	1:1	6000	32Nm		X	28.5	73.5	CHUB27	CHTAER25ZC ■	OKU0290009 ■	
BAR0070425	BAR0071425	ERA25	1:1	6000	32Nm	P=70bar	X	28.5	83.5	CHUB27	CHTAER25ZC ■	OKU0290009 ■	
BAR0070516	BAR0071516	WELDON16	1:1	6000	32Nm		X		27.5	73.5	-	-	-

- Chiave inclusa
- Key included
- Schluessel inbegriffen

BARUFFALDI  
VDI 30

MODULO MOTORIZZATO RADIALE ARRETRATO VDI30 H=85mm  
Radial rear-set driven tool VDI30 H=85mm  
Radial angetriebenes Werkzeug zurueckversetzt VDI30 H=85mm

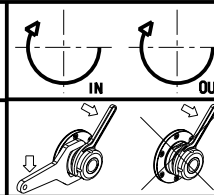

**M.T. srl**  
Via Casino Albini 480  
Tel. 0541/956034-957884  
Fax 0541/956341  
47842 S. GIOVANNI IN M. (RN)  
e-mail: mtma@mtmarchetti.com  
http://www.mtmarchetti.com

PRODUZIONE MODULI ROTANTI



PAGINA BAR015-1-70

Subject to change without notice.

10/2018

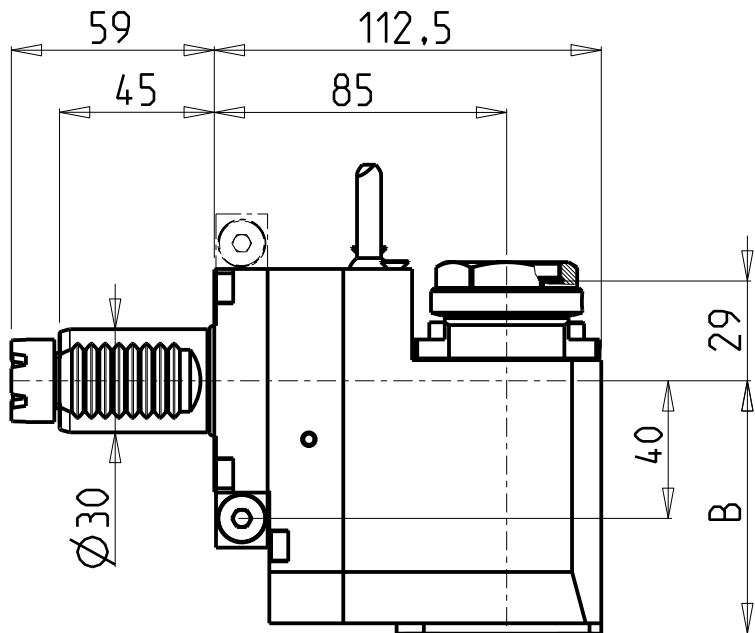

versione dx  
right version  
version rechts

versione sx  
left version  
version links

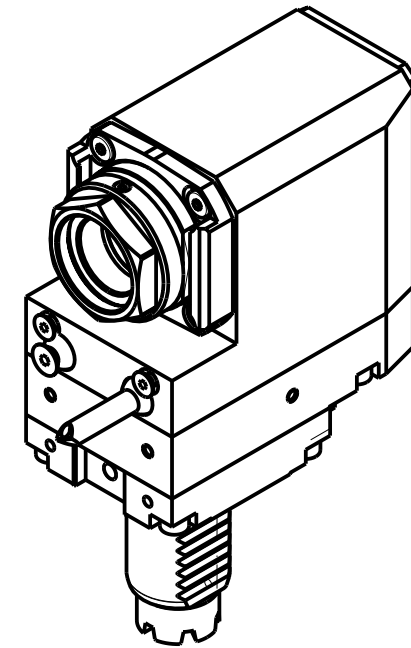
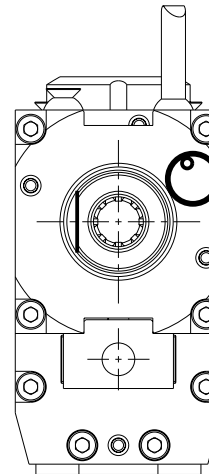
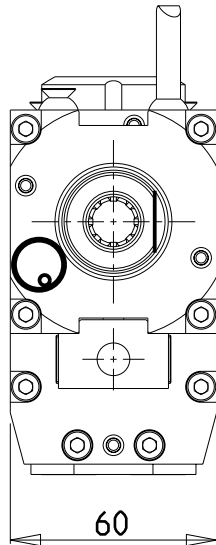

PER PORTAUTENSILI MODULARI MTSK-32 VEDI PAG. TBL300-1-32  
FOR MTSK-32 QUICK CHANGE TOOLHOLDERS CLAMPINGS SEE PAGE TBL300-1-32  
FUER MTSK-32 MODULARE WERKZEUGAUFNAHMEN SIEHE SEITE TBL300-1-32

- Chiave inclusa
- Key included
- Schlüssel inbegriffen

Cod. MT		Mandrino Spindle Spindel	I	RPM	Coppia Max Max Torque Max Drehmoment	Lubrificazione int. Coolant through Innenkuehlung	Lubrificazione est. Ext. coolant Aussenkuehlung	B	CHIAVI NON INCLUSE Keys not included Schlüssel nicht einbegriffen	
versione dx right version version rechts	versione sx left version version links								C HUB36	OKU0290009 ■
BAR0160132	BAR0161132	MTSK-32	1:1	6000	32Nm	-	X	73.5	C HUB36	OKU0290009 ■
BAR0160232	BAR0161232	MTSK-32	1:1	6000	32Nm	P=70bar	X	83.5	C HUB36	OKU0290009 ■

BARUFFALDI  
VDI 30

MODULO MOTORIZZATO RADIALE ARRETRATO MTSK VDI30 H=85mm  
Radial MTSK rear-set driven tool VDI30 H=85mm  
Radial MTSK angetriebenes Werkzeug zurueckversetzt VDI30 H=85mm

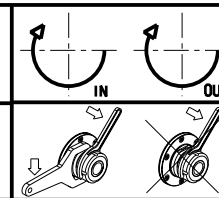

**M.T. srl**  
Via Casino Albini 480  
Tel. 0541/956034-957884  
Fax 0541/956341  
47842 S. GIOVANNI IN M. (RN)  
e-mail: mtma@mtmarchetti.com  
http://www.mtmarchetti.com

PRODUZIONE MODULI ROTANTI



PAGINA BAR015-1-70-K

Subject to change without notice.

10/2018